



US 20040080561A1

(19) **United States**

(12) **Patent Application Publication**  
**Silverbrook**

(10) **Pub. No.: US 2004/0080561 A1**

(43) **Pub. Date: Apr. 29, 2004**

(54) **COMPOSITE SUPPORT BEAM FOR PRINthead ASSEMBLY**

(52) **U.S. Cl. .... 347/20**

(75) **Inventor: Kia Silverbrook, Balmain (AU)**

(57) **ABSTRACT**

Correspondence Address:  
**SILVERBROOK RESEARCH PTY LTD**  
**393 DARLING STREET**  
**BALMAIN 2041 (AU)**

A printhead assembly for an inkjet printer, the printhead assembly comprising:

(73) **Assignee: Silverbrook Research Pty Ltd**

a support member (3) for mounting the printhead assembly within an inkjet printer;

(21) **Appl. No.: 10/728,802**

a plurality of printhead modules (2) mounted to the support member (3). The support member (3) has a first component (6) and a second component (5); wherein,

(22) **Filed: Dec. 8, 2003**

**Related U.S. Application Data**

(63) **Continuation-in-part of application No. 10/129,437, filed on May 6, 2002.**

(30) **Foreign Application Priority Data**

Mar. 9, 2000 (AU)..... PQ6111

**Publication Classification**

(51) **Int. Cl.<sup>7</sup> ..... B41J 2/015**

the first component (6) has a coefficient of thermal expansion that differs from the coefficient of thermal expansion of the printhead modules (2). The second component (5) has a coefficient of thermal expansion that differs from the coefficient of thermal expansion of the first component (6) to give the printhead assembly (1) an overall coefficient of thermal expansion that matches, or is closer to, that of the modules (2) so that aligning the printing from each of the individual modules (2) is easier.

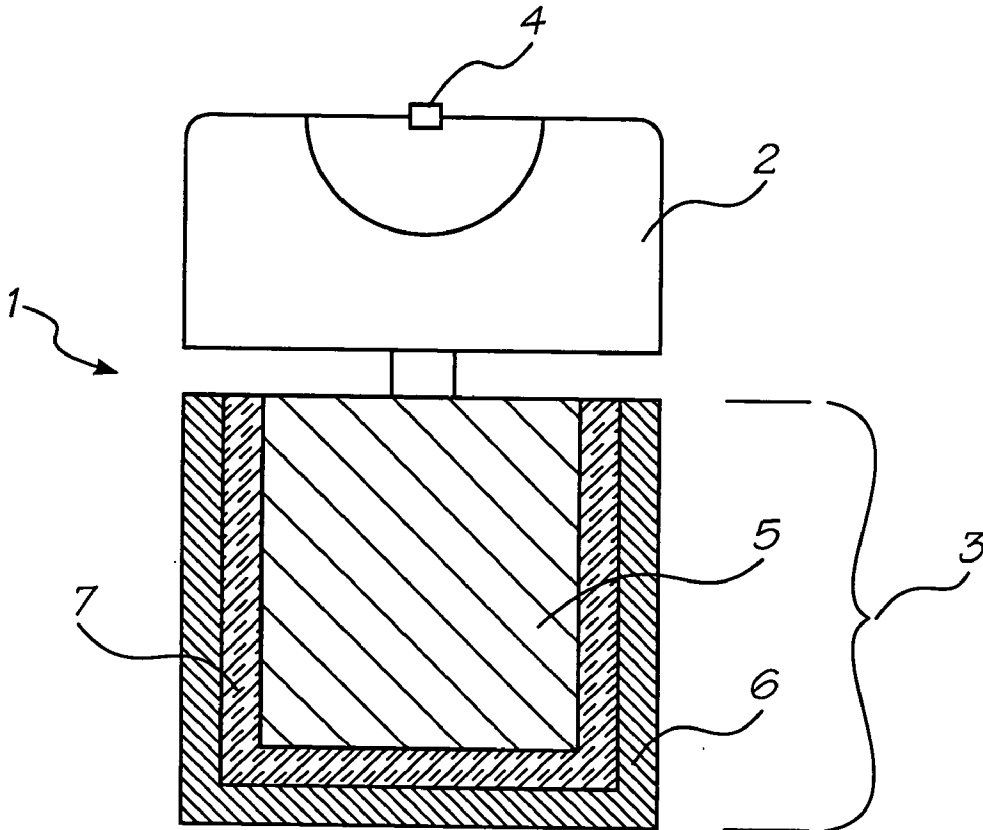

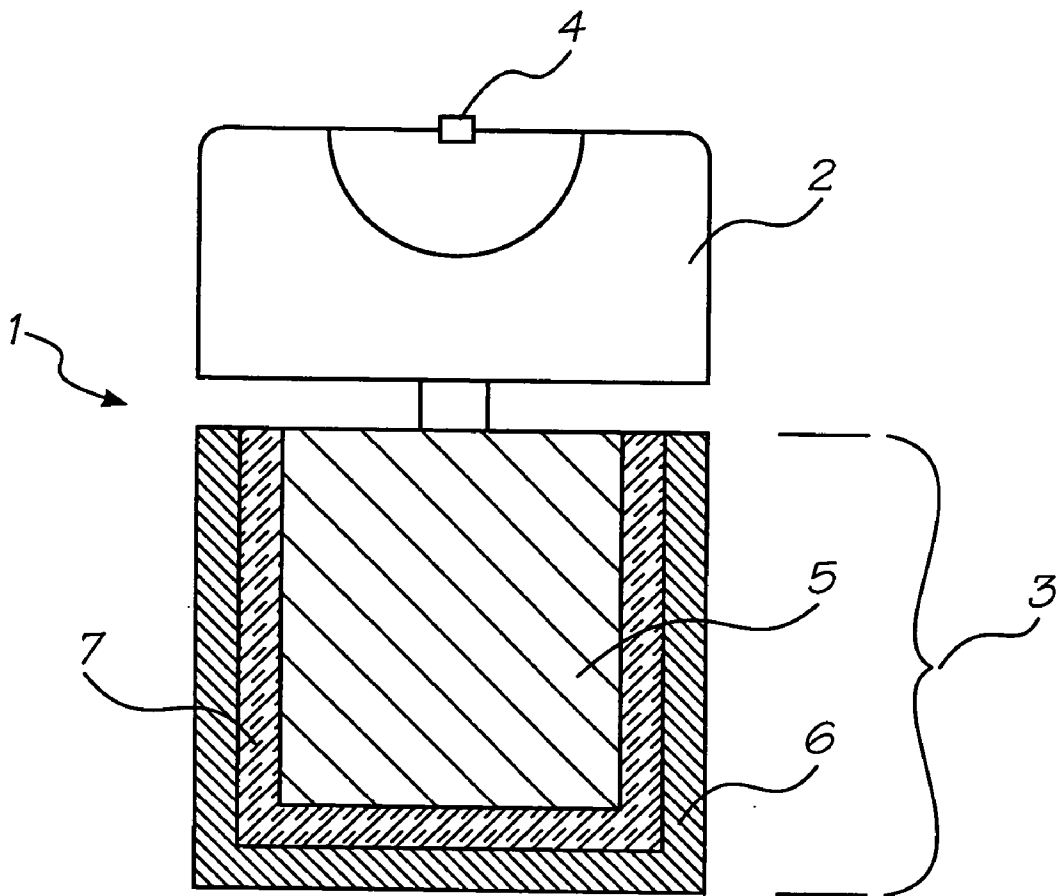

FIG. 1

## COMPOSITE SUPPORT BEAM FOR PRINthead ASSEMBLY

[0001] This is a Continuation-In-Part of U.S. application Ser. No. 10/129,437 filed on May 6, 2002

### FIELD OF THE INVENTION

[0002] The present invention relates to printers, and in particular to digital inkjet printers.

### CO-PENDING APPLICATIONS

[0003] Various methods, systems and apparatus relating to the present invention are disclosed in the following co-pending applications filed by the applicant or assignee of the present invention on 24 May 2000:

---

PCT/AU00/00578 PCT/AU00/00579 PCT/AU00/00581 PCT/AU00/00580  
 PCT/AU00/00582 PCT/AU00/00587 PCT/AU00/00588 PCT/AU00/00589  
 PCT/AU00/00583 PCT/AU00/00593 PCT/AU00/00590 PCT/AU00/00591  
 PCT/AU00/00592 PCT/AU00/00584 PCT/AU00/00585 PCT/AU00/00586  
 PCT/AU00/00594 PCT/AU00/00595 PCT/AU00/00596 PCT/AU00/00597  
 PCT/AU00/00598 PCT/AU00/00516 PCT/AU00/00517 PCT/AU00/00511

---

[0004] Various methods, systems and apparatus relating to the present invention are disclosed in the following co-pending application, PCT/AU00/01445, filed by the applicant or assignee of the present invention on 27 Nov. 2000. The disclosures of these co-pending applications are incorporated herein by cross-reference. Also incorporated by cross-reference are the disclosures of two co-filed PCT applications, PCT/AU01/00261 and PCT/AU01/00259 (deriving priority from Australian Provisional Patent Application No. PQ61 10 and PQ6158). Further incorporated are the disclosures of two co-pending PCT applications filed 6 Mar. 2001, application numbers PCT/AU01/00238 and PCT/AU01/00239, which derive their priority from Australian Provisional Patent Application nos. PQ6059 and PQ6058.

### BACKGROUND OF THE INVENTION

[0005] Recently, inkjet printers have been developed which use printheads manufactured by micro-electro mechanical systems (MEMS) techniques. Such printheads have arrays of microscopic ink ejector nozzles formed in a silicon chip using MEMS manufacturing techniques. The invention will be described with particular reference to silicon printhead chips for digital inkjet printers wherein the nozzles, chambers and actuators of the chip are formed using MEMS techniques. However, it will be appreciated that this is in no way restrictive and the invention may also be used in many other applications.

[0006] Silicon printhead chips are well suited for use in pagewidth printers having stationary printheads. These printhead chips extend the width of a page instead of traversing back and forth across the page, thereby increasing printing speeds. The probability of a production defect in an eight inch long chip is much higher than a one inch chip. The high defect rate translates into relatively high production and operating costs.

[0007] To reduce the production and operating costs of pagewidth printers, the printhead may be made up of a series

of separate printhead modules mounted adjacent one another, each module having its own printhead chip. To ensure that there are no gaps or overlaps in the printing produced by adjacent printhead modules it is necessary to accurately align the modules after they have been mounted to a support beam. Once aligned, the printing from each module precisely abuts the printing from adjacent modules.

[0008] Unfortunately, the alignment of the printhead modules at ambient temperature will change when the support beam expands as it heats up to the temperature it maintains during operation.

### SUMMARY OF THE INVENTION

[0009] Accordingly, the present invention provides a printhead assembly for an ink-jet printer, the printhead assembly comprising:

[0010] a support member for mounting the printhead assembly within an inkjet printer;

[0011] a plurality of printhead modules mounted to the support member;

[0012] the support member has a first component and a second component; wherein,

[0013] the first component has a coefficient of thermal expansion that differs from the coefficient of thermal expansion of the printhead modules;

[0014] the second component with a coefficient of thermal expansion that differs from the coefficient of thermal expansion of the first component to give the printhead assembly an overall coefficient of thermal expansion; such that,

[0015] the difference between the overall coefficient of thermal expansion and the coefficient of thermal expansion of the printhead modules, is less than,

[0016] the difference between the coefficient of thermal expansion of the first component and the coefficient of thermal expansion of the printhead modules.

[0017] Printhead assemblies according to the present invention use a composite support member so that one component can be a high strength low cost material such as steel, and another component can be selected so that the overall coefficient of thermal expansion of the support member matches, or is at least closer to, that of the printhead modules. By reducing the difference between the thermal expansion of the printhead modules and the support member, the printing alignment of individual modules with their adjacent modules is easier.

[0018] Preferably, the support member is a beam and the printhead modules include MEMS manufactured chips having at least one fiducial on each;

[0019] wherein,

[0020] the fiducials are used to misalign the printhead modules by a distance calculated from:

[0021] i) the difference between the coefficient of thermal expansion of the beam and the printhead chips;

[0022] ii) the spacing of the printhead chips along the beam; and,

[0023] iii) the difference between the production temperature and the operating temperature.

[0024] Conveniently, the first component of the beam is an outer metal shell, and the second component of the beam is a core of silicon with the outer metal shell. In a further preferred embodiment, the beam is adapted to allow limited relative movement between the silicon core and the metal shell. To achieve this, the beam may include an elastomeric layer interposed between the silicon core and metal shell. In other forms, the outer shell may be formed from laminated layers of at least two different metals.

#### BRIEF DESCRIPTION OF THE DRAWING

[0025] A preferred embodiment of the invention will now be described, by way of example only, with reference to the accompanying drawing in which:

[0026] FIG. 1 shows a schematic cross section of a printhead assembly according to the present invention.

#### DETAILED DESCRIPTION OF PREFERRED EMBODIMENTS

[0027] Referring to the figure the printhead assembly 1 has a plurality of printhead modules 2 mounted to a support member 3 in a printer (not shown). The printhead module includes a silicon printhead chip 4 in which the nozzles, chambers, and actuators are manufactured using MEMS techniques. Each printhead chip 4 has at least 1 fiducial (not shown) for aligning the printheads. Fiducials are reference markings placed on silicon chips and the like so that they may be accurately positioned using a microscope.

[0028] According to one embodiment of the invention, the printheads are aligned while the printer is operational and the assembly is at the printing temperature. If it is not possible to view the fiducial marks while the printer is operating, an alternative system of alignment is to misalign the printhead modules on the support beam 3 such that when the printhead assembly heats up to the operating temperature, the printheads move into alignment. This is easily achieved by adjusting the microscope by the set amount of misalignment required or simply misaligning the printhead modules by the required amount.

[0029] The required amount is calculated using the difference between the coefficients of thermal expansion of the printhead modules and the support beam, the length of each individual printhead module and the difference between ambient temperature and the operating temperature. The printer is designed to operate with acceptable module alignment within a temperature range that will encompass the vast majority of environments in which it expected to work. A typical temperature range may be 0° C. to 40° C. During operation, the operating temperature of the printhead rise a fixed amount above the ambient temperature in which the printer is operating at the time. Say this increase is 50° C., the temperature range in which the alignment of the modules must be within the acceptable limits is 50° C. to 90° C. Therefore, when misaligning the modules during production of the printhead, the production temperature should be carefully maintained at 20° C. to ensure that the alignment

is within acceptable limits for the entire range of predetermined ambient temperatures (i.e. 0° C. to 40° C.).

[0030] To minimize the difference in coefficient of thermal expansion between the printhead modules and the support beam 3, the support beam has a silicon core 5 mounted within a metal channel 6. The metal channel 6 provides a strong cost effective structure for mounting within a printer while the silicon core provides the mounting points for the printhead modules and also helps to reduce the coefficient of thermal expansion of the support beam 3 as a whole. To further isolate the silicon core from the high coefficient of thermal expansion in the metal channel 6 an elastomeric layer 7 is positioned between the core 5 and the channel 6. The elastomeric layer 7 allows limited movement between the metal channel 6 and the silicon core 5. It will be appreciated that the maximum relative movement between the channel and the core will be known from the known properties of the materials used, and the known difference between the production temperature and the known operating temperature. From this, it is a simple matter to select a suitable elastomeric material and a suitable thickness of the elastomeric layer. In this way the thermal expansion of the metal channel or the core (or indeed the support beam as a whole) is not constrained but the normally high degree of thermal of the channel is significantly reduced.

[0031] The invention has been described with reference to specific embodiments. The ordinary worker in this field will readily recognise that the invention may be embodied in many other forms.

1. A printhead assembly for an inkjet printer, the printhead assembly comprising:

a support member for mounting the printhead assembly within an inkjet printer;

a plurality of printhead modules mounted to the support member;

the support member has a first component and a second component; wherein,

the first component has a coefficient of thermal expansion that differs from the coefficient of thermal expansion of the printhead modules;

the second component with a coefficient of thermal expansion that differs from the coefficient of thermal expansion of the first component to give the printhead assembly an overall coefficient of thermal expansion; such that,

the difference between the overall coefficient of thermal expansion and the coefficient of thermal expansion of the printhead modules, is less than,

the difference between the coefficient of thermal expansion of the first component and the coefficient of thermal expansion of the printhead modules.

2. A printhead assembly according to claim 1 wherein the support member is a beam and the printhead modules include MEMS manufactured chips having at least one fiducial on each;

wherein,

the fiducials are used to misalign the printhead modules by a distance calculated from:

- i) the difference between the coefficient of thermal expansion of the beam and the printhead chips;
- ii) the spacing of the printhead chips along the beam; and,
- iii) the difference between the production temperature and the operating temperature.

3. A printhead assembly according to claim 2 wherein the first component of the beam is an outer metal shell, and the second component of the beam is a core of silicon with the outer metal shell.

4. A printhead assembly according to claim 3 wherein the beam is adapted to allow limited relative movement between the silicon core and the metal shell.

5. A printhead assembly according to claim 4 wherein the beam includes an elastomeric layer interposed between the silicon core and metal shell.

6 A printhead assembly according to claim 3 wherein the outer shell is formed from laminated layers of at least two different metals.

7. A printhead assembly according to claim 1 wherein the printhead is a pagewidth printhead for printing across the width of a page simultaneously.

\* \* \* \* \*