



INTERNATIONAL APPLICATION PUBLISHED UNDER THE PATENT COOPERATION TREATY (PCT)

<p>(51) International Patent Classification ⁷ : G06F 1/00, 12/14</p>	<p>A1</p>	<p>(11) International Publication Number: WO 00/11534 (43) International Publication Date: 2 March 2000 (02.03.00)</p>
<p>(21) International Application Number: PCT/FI99/00693 (22) International Filing Date: 23 August 1999 (23.08.99) (30) Priority Data: 981819 25 August 1998 (25.08.98) FI (71) Applicant (for all designated States except US): NOKIA NETWORKS OY [FI/FI]; P.O. Box 300, FIN-00045 Nokia Group (FI). (72) Inventor; and (75) Inventor/Applicant (for US only): OSMONEN, Heikki [FI/FI]; Kolsarinkuja 6 B 12, FIN-00390 Helsinki (FI). (74) Agent: PAPULA REIN LAHTELA OY; P.O. Box 981, (Fredrikinkatu 61 A), FIN-00101 Helsinki (FI).</p>		<p>(81) Designated States: AE, AL, AM, AT, AU, AZ, BA, BB, BG, BR, BY, CA, CH, CN, CR, CU, CZ, DE, DK, DM, EE, ES, FI, GB, GD, GE, GH, GM, HR, HU, ID, IL, IN, IS, JP, KE, KG, KP, KR, KZ, LC, LK, LR, LS, LT, LU, LV, MD, MG, MK, MN, MW, MX, NO, NZ, PL, PT, RO, RU, SD, SE, SG, SI, SK, SL, TJ, TM, TR, TT, UA, UG, US, UZ, VN, YU, ZA, ZW, ARIPO patent (GH, GM, KE, LS, MW, SD, SL, SZ, UG, ZW), Eurasian patent (AM, AZ, BY, KG, KZ, MD, RU, TJ, TM), European patent (AT, BE, CH, CY, DE, DK, ES, FI, FR, GB, GR, IE, IT, LU, MC, NL, PT, SE), OAPI patent (BF, BJ, CF, CG, CI, CM, GA, GN, GW, ML, MR, NE, SN, TD, TG).</p> <p>Published <i>With international search report. Before the expiration of the time limit for amending the claims and to be republished in the event of the receipt of amendments.</i></p>

(54) Title: METHOD AND SYSTEM FOR APPROVING A PASSWORD

(57) Abstract

Method and system for approving a password corresponding to a user identifier in a user identification system in which the user identifier is associated with a user profile and in which the password consists of characters comprised in a total range of characters. According to the invention, a data item indicating whether the password should contain a character belonging to a predefined subset in the total range of characters is added to the user profile.

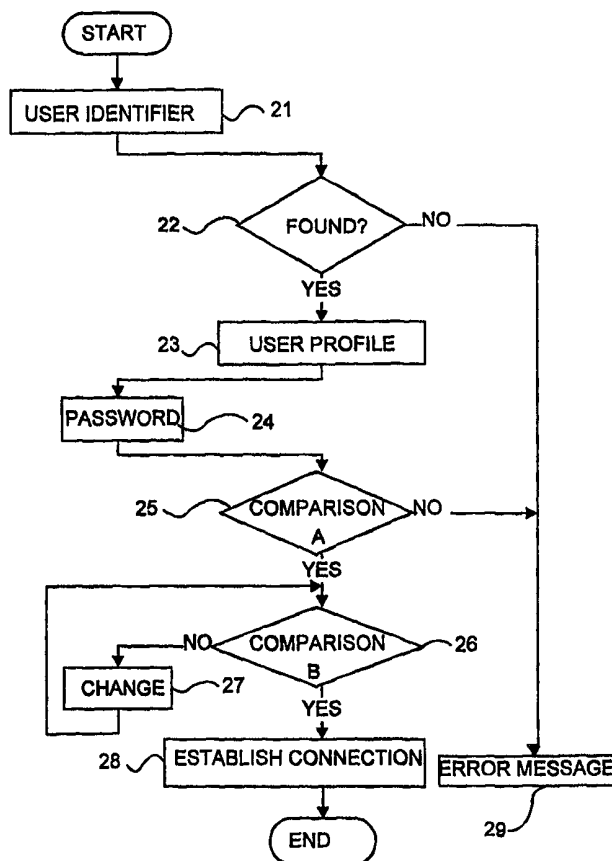

FOR THE PURPOSES OF INFORMATION ONLY

Codes used to identify States party to the PCT on the front pages of pamphlets publishing international applications under the PCT.

AL	Albania	ES	Spain	LS	Lesotho	SI	Slovenia
AM	Armenia	FI	Finland	LT	Lithuania	SK	Slovakia
AT	Austria	FR	France	LU	Luxembourg	SN	Senegal
AU	Australia	GA	Gabon	LV	Latvia	SZ	Swaziland
AZ	Azerbaijan	GB	United Kingdom	MC	Monaco	TD	Chad
BA	Bosnia and Herzegovina	GE	Georgia	MD	Republic of Moldova	TG	Togo
BB	Barbados	GH	Ghana	MG	Madagascar	TJ	Tajikistan
BE	Belgium	GN	Guinea	MK	The former Yugoslav Republic of Macedonia	TM	Turkmenistan
BF	Burkina Faso	GR	Greece	ML	Mali	TR	Turkey
BG	Bulgaria	HU	Hungary	MN	Mongolia	TT	Trinidad and Tobago
BJ	Benin	IE	Ireland	MR	Mauritania	UA	Ukraine
BR	Brazil	IL	Israel	MW	Malawi	UG	Uganda
BY	Belarus	IS	Iceland	MX	Mexico	US	United States of America
CA	Canada	IT	Italy	NE	Niger	UZ	Uzbekistan
CF	Central African Republic	JP	Japan	NL	Netherlands	VN	Viet Nam
CG	Congo	KE	Kenya	NO	Norway	YU	Yugoslavia
CH	Switzerland	KG	Kyrgyzstan	NZ	New Zealand	ZW	Zimbabwe
CI	Côte d'Ivoire	KP	Democratic People's Republic of Korea	PL	Poland		
CM	Cameroon	KR	Republic of Korea	PT	Portugal		
CN	China	KZ	Kazakstan	RO	Romania		
CU	Cuba	LC	Saint Lucia	RU	Russian Federation		
CZ	Czech Republic	LI	Liechtenstein	SD	Sudan		
DE	Germany	LK	Sri Lanka	SE	Sweden		
DK	Denmark	LR	Liberia	SG	Singapore		
EE	Estonia						

METHOD AND SYSTEM FOR APPROVING A PASSWORD**FIELD OF THE INVENTION**

The present invention concerns a method as
5 defined in the preamble of claim 1 and a system as de-
fined in the preamble of claim 5 for approving a pass-
word.

BACKGROUND OF THE INVENTION

10 It is a generally known practice to use a
user identifier and a corresponding password as a key
to accessing information systems. This improves the
safety of information systems and prevents information
15 from being accessed by parties for which it is not in-
tended. A password is a given string which is used to
identify a user who logs in to a system by giving
his/her user identifier.

The person maintaining the information system
20 may make a definition in the user identification sys-
tem requiring that special characters be included in
all passwords. Special characters are symbols not in-
cluded in the basic alphabet. The use of special char-
acters further improves data security because the
25 larger the choice of characters for a password, the
larger will be the number of character combinations to
try and the more difficult will it be to break up the
password.

In certain MMI systems (MMI, Man Machine In-
30 terface), a separate user profile is created for each
user. The user profile defines e.g. which MML commands
the user is authorised to execute, and it is associ-
ated with the user name. When the user issues a com-
mand, the system checks whether the session in ques-
tion has the authority to execute that command.

35 In the above-mentioned user identification
system, a problem is that the use of special charac-

ters in a password is either optional or obligatory for all users. However, in many information systems, it would be important to require of certain users that they use longer passwords including special characters. Such passwords are more difficult to break up. At present, it is not possible for a person maintaining a user identification system to define which users are required to include more special characters in their passwords than others.

10 The object of the present invention is to eliminate the drawbacks described above or at least to significantly alleviate them.

 A specific object of the present invention is to disclose a new type of method and system for approval of a password corresponding to a user identifier.

BRIEF DESCRIPTION OF THE INVENTION

 In the method of the present invention for approving a password in a user identification system, in which the user identifier is associated with a user profile, a definition is made for each user profile, specifying whether the password should include special characters. Special characters are characters belonging to a predefined subset in a total range of characters, which includes all available characters. According to the invention, data indicating whether the password should include a character belonging to a predefined subset of the total range of characters is added to the user profile.

 In an embodiment of the method, data indicating the minimum number of characters belonging to a predefined subset in the total range of characters is added to the user profile. In this case, the user must use a password containing at least the minimum number of special characters. The number of special charac-

ters is preferably verified in the user identification system.

In an embodiment of the method, when a user changes his/her password, a check is performed before approval of the new password to verify whether the password contains at least the required number of characters belonging to a predefined subset in the total range of characters.

The system of the invention for approving a password in a user identification system in which a user identifier is associated with a user profile comprises an information system which a user can only access if the user identification system approves the user on the basis of the user identifier and password.

According to the invention, the user identification system comprises means for adding to the user profile a data item indicating the presence in the password of a character belonging to a predefined subset in a total range of characters. The total range of characters comprises all the available characters.

In an embodiment of the system, the user identification system comprises means for adding to the user profile a data item indicating a required minimum number of characters belonging to a predefined subset in the total range of characters. Means for comparing and verifying the number of characters belonging to a predefined subset in the total range of characters that are present in the password and the number of characters required in the user profile are preferably comprised in the user identification system.

Further, the system preferably also comprises means for checking the password to verify whether it contains the required number of characters belonging to a predefined subset in the total range of characters before a new password is approved when the password is to be changed.

The invention improves the data security of a MML system for those users whose user profile includes a setting requiring the use of many special characters. At the same time, for users who are only entitled to execute MML language commands of the lowest levels, a user profile can be set that does not require the use of special characters. This makes the password easier to remember and allows easier and faster access to the system.

The invention gives the person maintaining the user identification system a chance to decide which ones of the users are required to use special characters in their passwords and which ones are not.

LIST OF ILLUSTRATIONS

In the following, the invention will be described in detail by the aid of a few examples of its embodiments, wherein

Fig. 1 presents an embodiment of the system of the invention, and

Fig. 2 presents a block diagram illustrating the operation of the embodiment according to Fig. 1.

DETAILED DESCRIPTION OF THE INVENTION

The system illustrated in Fig. 1 comprises a user interface 11 serving as a means of controlling an information system 12. The user of the user interface must have the authority to access the information system. This authority is checked in a user identification system 13, where the user is asked to give a user identifier and a password. A preferred system for the embodiment in this example is the Nokia DX 200 telephone switching system, which has an MML user interface and uses commands that are entered in the MML language. These means 11, 12, 13 are implemented in a

manner known in itself and they will therefore not be described here in greater detail.

The user identification system 13 comprises means 1 for adding to the user profile a data item indicating a character belonging to a predefined subset in the total range of characters. A data item indicating a minimum number of characters belonging to a predefined subset in the total range of characters is added to the user profile using means 2. Moreover, the user identification system comprises means 3 for modifying the user profile when the password is changed and means 4 for finding the required number of characters belonging to a predefined subset in the total range of characters before the password is approved. In the case of the example, these means 1, 2, 3, 4 are implemented via software.

In the following, the events in the example will be described step by step with reference to the operational block diagram in Fig. 2.

The user is asked to give a user identifier, which he/she enters via the user interface 11, block 21. The user identification system 13 verifies whether the user identifier entered has been stored in the user identification system, block 22. If the user identifier entered is unknown, then the procedure will go on to block 29, where the user is presented an error message and user identification is terminated. If the user identifier is found, then the procedure will be continued.

The user identification system 13 identifies the user profile by the user identifier and retrieves the stored information corresponding to the user profile, block 23. Based on this information, the user identification system knows the password corresponding to the user identifier, the length of the password and the minimum number of characters belonging to a predefined subset in the total range of characters that the

password should contain. This subset comprises e.g. numeric characters or all special characters. In the case of the example, the subset consists of all the characters defined in the ITU-T (ITU-T, International Telecommunications Union - Telecommunications) standard IA5 (IA5, International Alphabet no. 5), in the following ranges: 21H - 40H, 5BH - 60H and 7BH - 7EH.

Further, the user is asked to enter the password corresponding to the user identifier supplied via the user interface 11. The user enters the password, block 24, whereupon the user identification system 13 checks the properties of the password, block 25. If the password entered differs from the password corresponding to the user identifier, i.e. from the one stored in the user identification system, then the user is given an error message and the identification process is terminated, block 29. Alternatively, the user may be given a few more chances to enter the password before the identification process is ended. If the password is correct, then the system checks whether the number of special characters in the password is as required in the user profile, block 26.

If the password does not contain the required minimum number of special characters, then the user will be asked to change the password so as to give it an acceptable form, block 27. After the user has changed his/her password, it will be checked again, block 26.

If the password meets the requirements imposed by the user identification system and the user profile, then a direct connection between the user interface 11 and the information system 12 will be set up from the user identification system 13, block 28. After this, the user identification system will not necessarily interfere with the connection in any way. However, e.g. the user's authority to execute certain MM1 commands may depend on the user profile.

In a system as presented in the example, a change of password can also be implemented in a way differing from the procedure presented in the example. For instance, the password characteristics required by the user profile may only be checked when the password is changed, in which case the user can retain his/her old password even if it does not meet the requirements imposed by the user profile, until he/she decides to change the passwords him/herself.

10 The invention is not restricted to the examples of its embodiments described above, but many variations are possible within the scope of the inventive idea defined in the claims

CLAIMS

1. Method for approving a password corresponding to a user identifier in a user identification system in which the user identifier is associated with
5 a user profile and the password consists of characters comprised in a total range of characters, characterised in that a data item indicating whether the password should contain a character belonging to a predefined subset in the total range of characters is
10 added to the user profile.

2. Method as defined in claim 1, characterised in that a data item indicating a minimum number of characters belonging to a predefined subset in the total range of characters that are to be
15 included in the password is added to the user profile.

3. Method as defined in claim 1 or 2, characterised in that a check is performed in the user identification system to verify whether the number of characters belonging to a predefined subset
20 in the total range of characters that are included in the password is as required in the user profile.

4. Method as defined in any one of claims 1 - 3, characterised in that, when a password is being changed, a check is performed before approval of
25 the new password to verify the number of characters in the password that belong to a predefined subset in the total range of characters.

5. System for approving a password corresponding to a user identifier in a user identification
30 system in which the user identifier is associated with a user profile and in which the password consists of characters comprised in a total range of characters, characterised in that the user identification system comprises means (1) for adding to the user pro-
35 file a data item indicating the presence in the password of a character belonging to a predefined subset in the total range of characters.

6. System as defined in claim 5, characterised in that the user identification system comprises means (2) for adding to the user profile a data item indicating a minimum number of characters belonging to a predefined subset in the total range of characters that should be included in the password.

7. System as defined in claim 5 or 6, characterised in that the user identification system comprises means (3) for comparing and verifying the number of characters in the password that belong to a predefined subset in the total range of characters and the number of characters required in the user profile.

8. System as defined in any one of claims 5 - 7, characterised in that the user identification system comprises means (4) for checking the password to verify the number of characters belonging to a predefined subset in the total range of characters when a password is being changed, before the new password is approved.

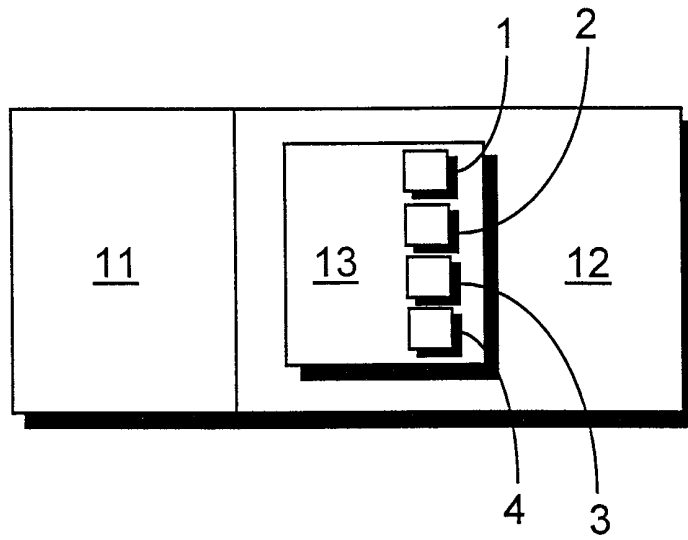

Fig. 1

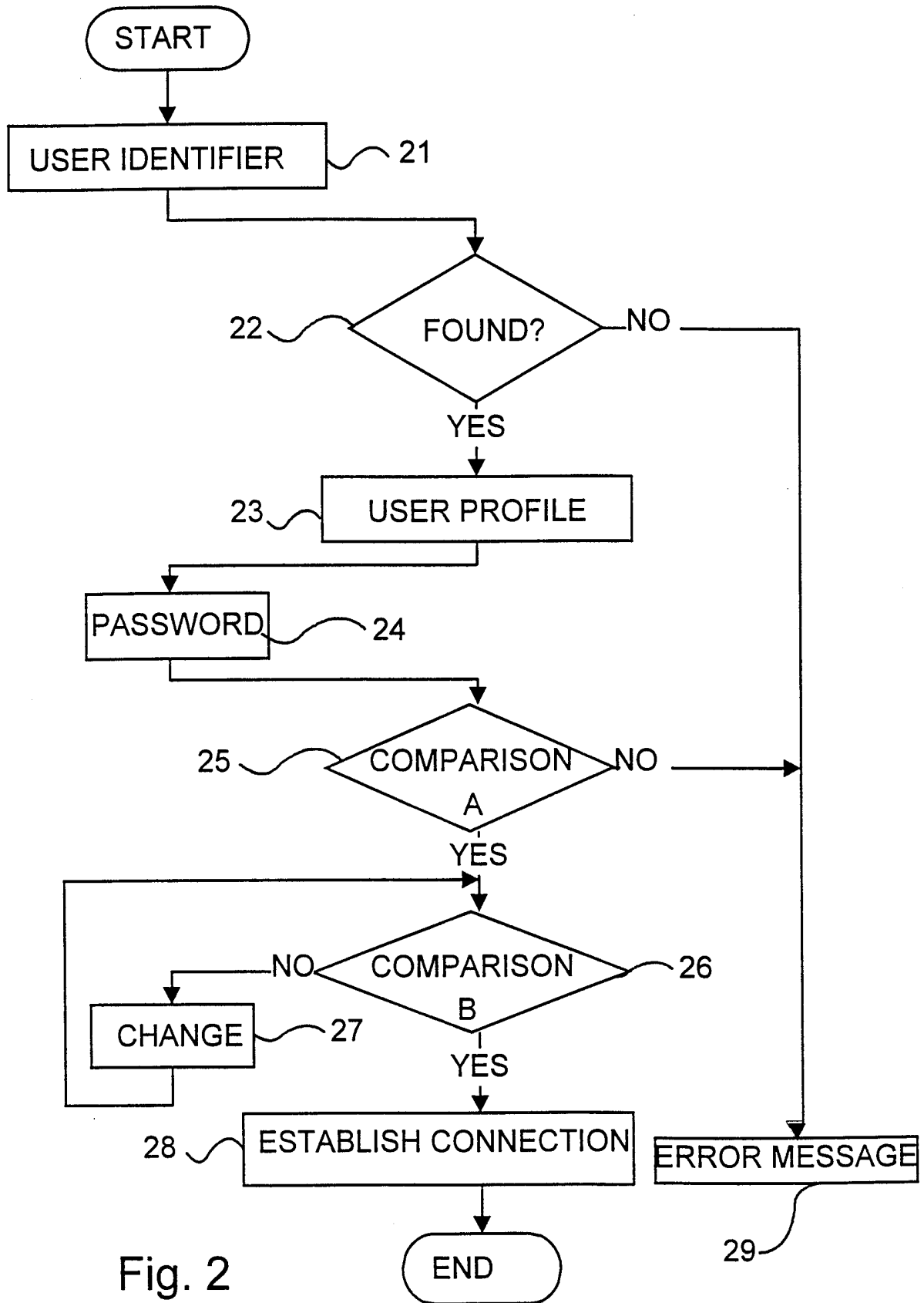

Fig. 2

INTERNATIONAL SEARCH REPORT

International application No.

PCT/FI 99/00693

A. CLASSIFICATION OF SUBJECT MATTER

IPC7: G06F 1/00, G06F 12/14

According to International Patent Classification (IPC) or to both national classification and IPC

B. FIELDS SEARCHED

Minimum documentation searched (classification system followed by classification symbols)

IPC7: G06F

Documentation searched other than minimum documentation to the extent that such documents are included in the fields searched

SE,DK,FI,NO classes as above

Electronic data base consulted during the international search (name of data base and, where practicable, search terms used)

C. DOCUMENTS CONSIDERED TO BE RELEVANT

Category*	Citation of document, with indication, where appropriate, of the relevant passages	Relevant to claim No.
X	US 5793952 A (CARL LIMSICO), 11 August 1998 (11.08.98), column 6, line 5 - line 17, figures 5B, 5F --	1-8
X	'HOWTO: Password Change Filtering & Notification in Windows NT' (online), article ID: Q151082 May, 1996 (retrieved on 2000-01-24) Retrieved from the Internet: <URL: http://support.microsoft.com/support/ kb/articles/q151/0/82.asp> Sample code on page 5-8. --	1-8
X	LOUNSBURY, A1. 'Steel-Cage Security for Windows NT', MCI Systemhouse, June 1998, (online), (retrieved on 2000-01-24) Retrieved from the Internet: <URL: http://www.data.com/tutorials/ cage.html> --	1-8

 Further documents are listed in the continuation of Box C. See patent family annex.

* Special categories of cited documents:

"A" document defining the general state of the art which is not considered to be of particular relevance

"E" earlier document but published on or after the international filing date

"I" document which may throw doubts on priority claim(s) or which is cited to establish the publication date of another citation or other special reason (as specified)

"O" document referring to an oral disclosure, use, exhibition or other means

"P" document published prior to the international filing date but later than the priority date claimed

"I" later document published after the international filing date or priority date and not in conflict with the application but cited to understand the principle or theory underlying the invention

"X" document of particular relevance: the claimed invention cannot be considered novel or cannot be considered to involve an inventive step when the document is taken alone

"Y" document of particular relevance: the claimed invention cannot be considered to involve an inventive step when the document is combined with one or more other such documents, such combination being obvious to a person skilled in the art

"&" document member of the same patent family

Date of the actual completion of the international search

26 January 2000

Date of mailing of the international search report

01-02-2000

Name and mailing address of the ISA:

Swedish Patent Office
Box 5055, S-102 42 STOCKHOLM
Facsimile No. +46 8 666 02 86

Authorized officer

Jan Silfverling/CL
Telephone No. +46 8 782 25 00

INTERNATIONAL SEARCH REPORT

International application No.

PCT/FI 99/00693

C (Continuation). DOCUMENTS CONSIDERED TO BE RELEVANT		
Category*	Citation of document, with indication, where appropriate, of the relevant passages	Relevant to claim No.
X	EP 0773489 A1 (IBM CORPORATION), 13 November 1995 (13.11.95), page 10, line 16 - line 20 --	1-8
A,T	US 5944825 A (JOHN BELLMORE ET AL), 31 August 1999 (31.08.99) -- -----	1-8

INTERNATIONAL SEARCH REPORT

Information on patent family members

02/12/99

International application No.

PCT/FI 99/00693

Patent document cited in search report	Publication date	Patent family member(s)	Publication date
US 5793952 A	11/08/98	NONE	
EP 0773489 A1	13/11/95	JP 9179826 A US 5832211 A CN 1156861 A JP 9179827 A US 5862323 A JP 9185584 A US 5838903 A	11/07/97 03/11/98 13/08/97 11/07/97 19/01/99 15/07/97 17/11/98
US 5944825 A	31/08/99	NONE	