



US 20240216144A1

(19) **United States**

(12) **Patent Application Publication**
Running et al.

(10) **Pub. No.: US 2024/0216144 A1**

(43) **Pub. Date: Jul. 4, 2024**

(54) **TOTAL REVERSE SHOULDER SYSTEMS AND METHODS**

Publication Classification

(71) Applicant: **Shoulder Innovations, Inc.**, Grand Rapids, MI (US)

(51) **Int. Cl.**
A61F 2/40 (2006.01)
A61B 17/17 (2006.01)
A61F 2/30 (2006.01)

(72) Inventors: **Donald E. Running**, Holland, MI (US);
Robert J. Ball, West Olive, MI (US);
Jason Slone, Silver Lake, IN (US)

(52) **U.S. Cl.**
CPC *A61F 2/4081* (2013.01); *A61B 17/1778* (2016.11); *A61F 2/30749* (2013.01); *A61F 2002/30616* (2013.01); *A61F 2002/4085* (2013.01)

(21) Appl. No.: **18/605,361**

(22) Filed: **Mar. 14, 2024**

(57) **ABSTRACT**

Related U.S. Application Data

(63) Continuation of application No. 18/477,416, filed on Sep. 28, 2023, which is a continuation of application No. 18/058,058, filed on Nov. 22, 2022, now Pat. No. 11,771,561, which is a continuation of application No. 17/435,333, filed on Aug. 31, 2021, filed as application No. PCT/US2020/022094 on Mar. 11, 2020.

(60) Provisional application No. 62/816,708, filed on Mar. 11, 2019.

A reverse shoulder system can include, for example, a glenoid baseplate comprising a longitudinal axis, the glenoid baseplate further including a stem and a central channel within a sidewall of the stem. The stem can include a longitudinal axis. The longitudinal axis of the glenoid baseplate can be angled with respect to the longitudinal axis of the stem, wherein the longitudinal axis of the glenoid baseplate is not perpendicular with respect to the longitudinal axis of the stem. Other components including a glenosphere, tools, and methods of use are also disclosed.

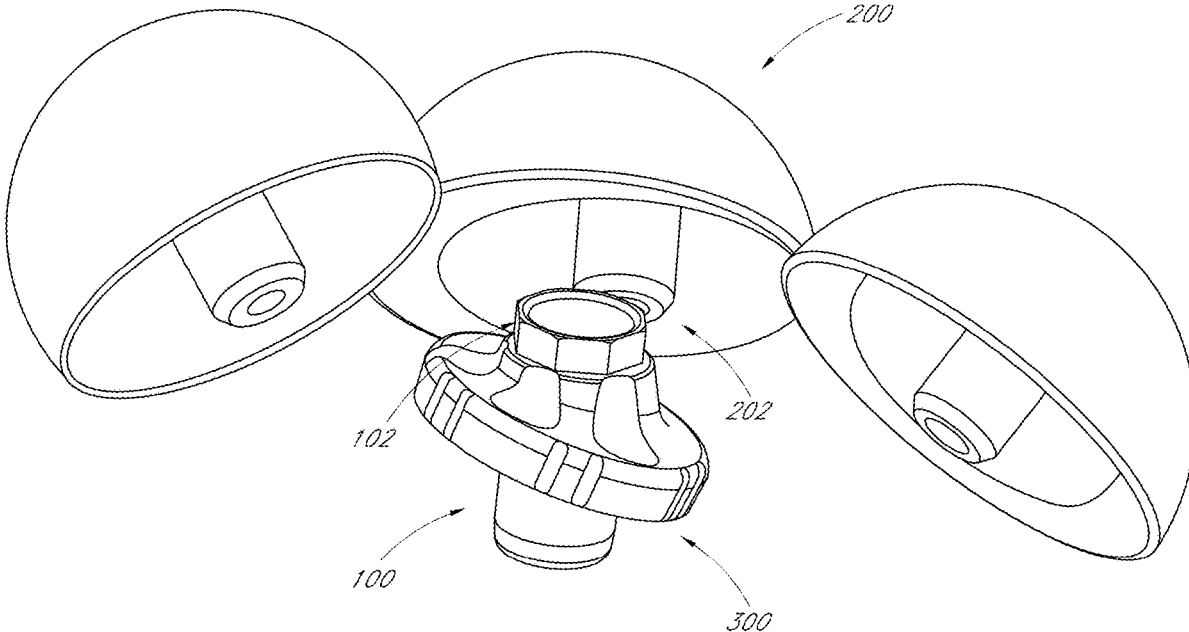

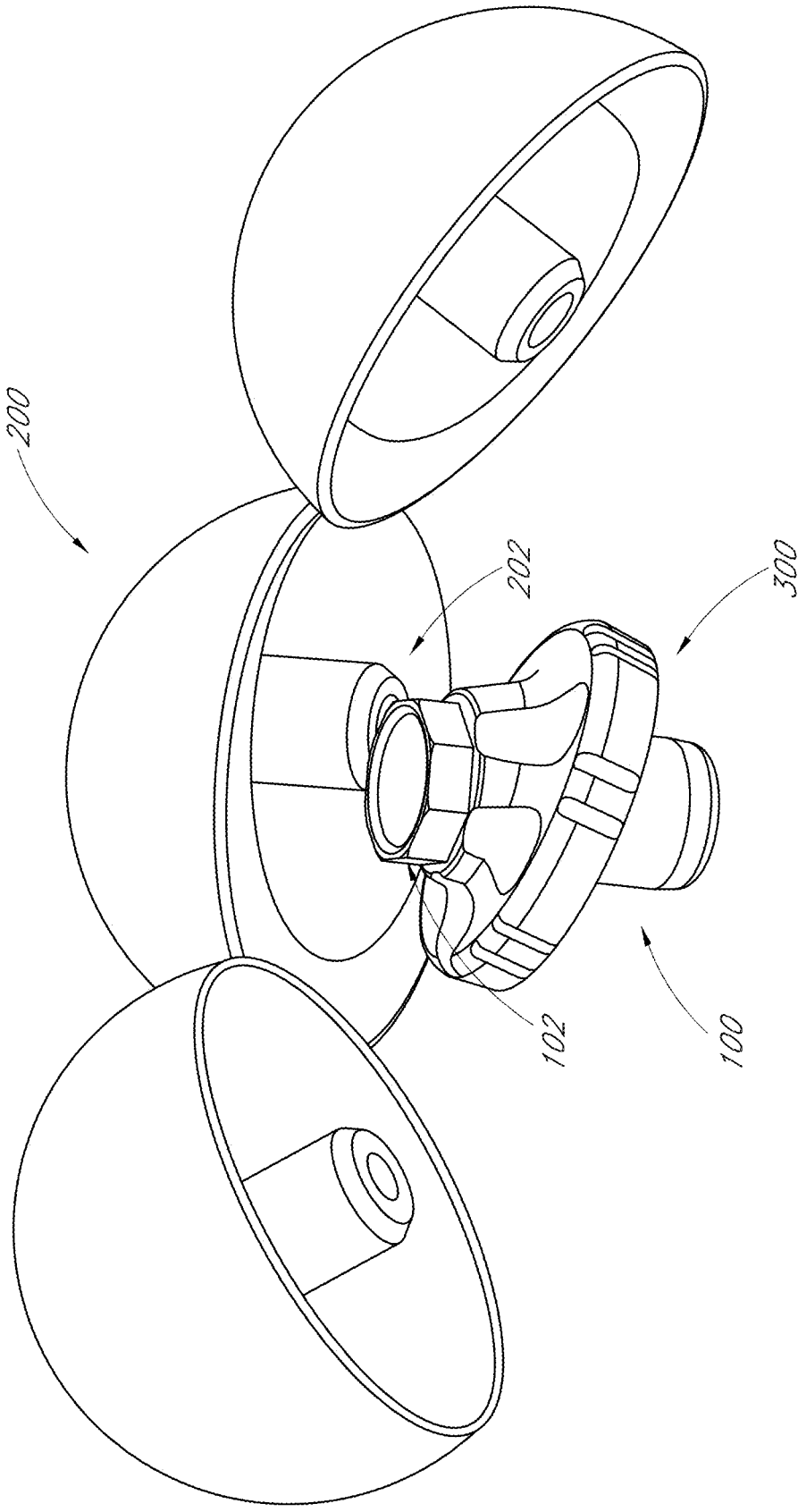

FIG. 1

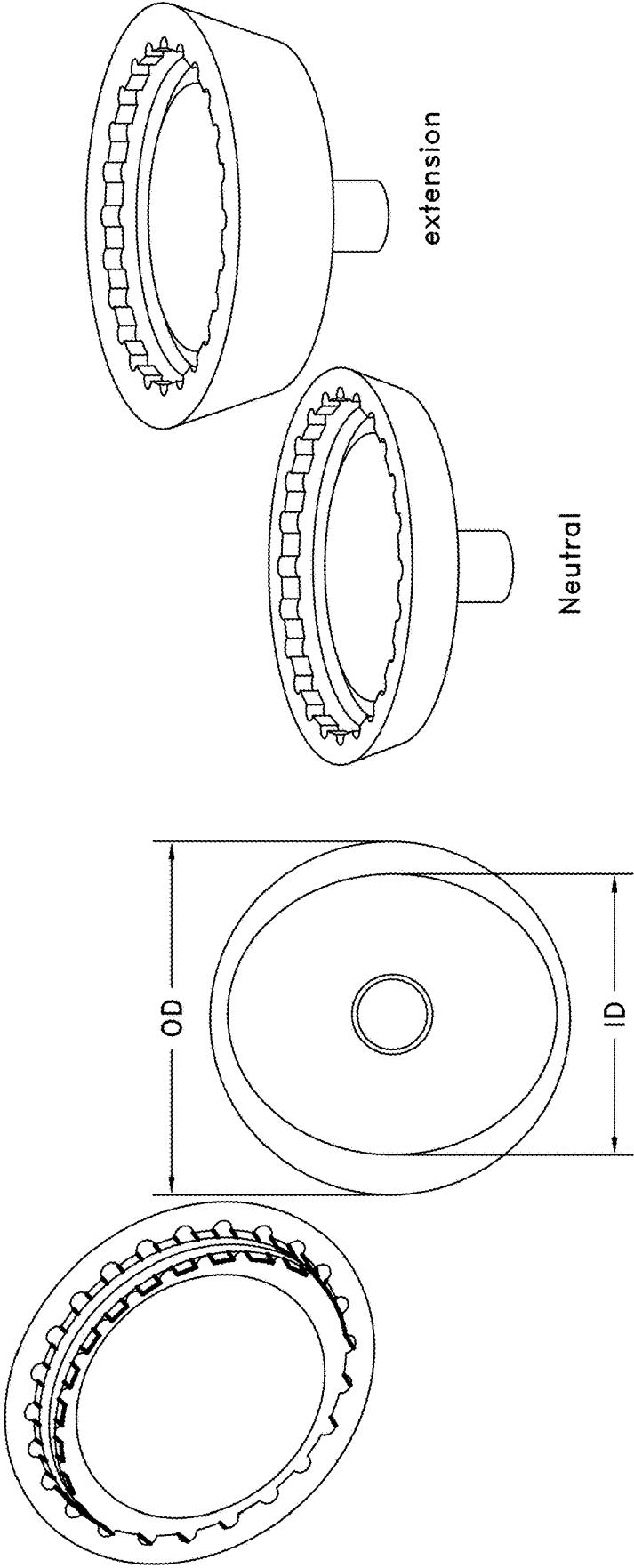

FIG. 2

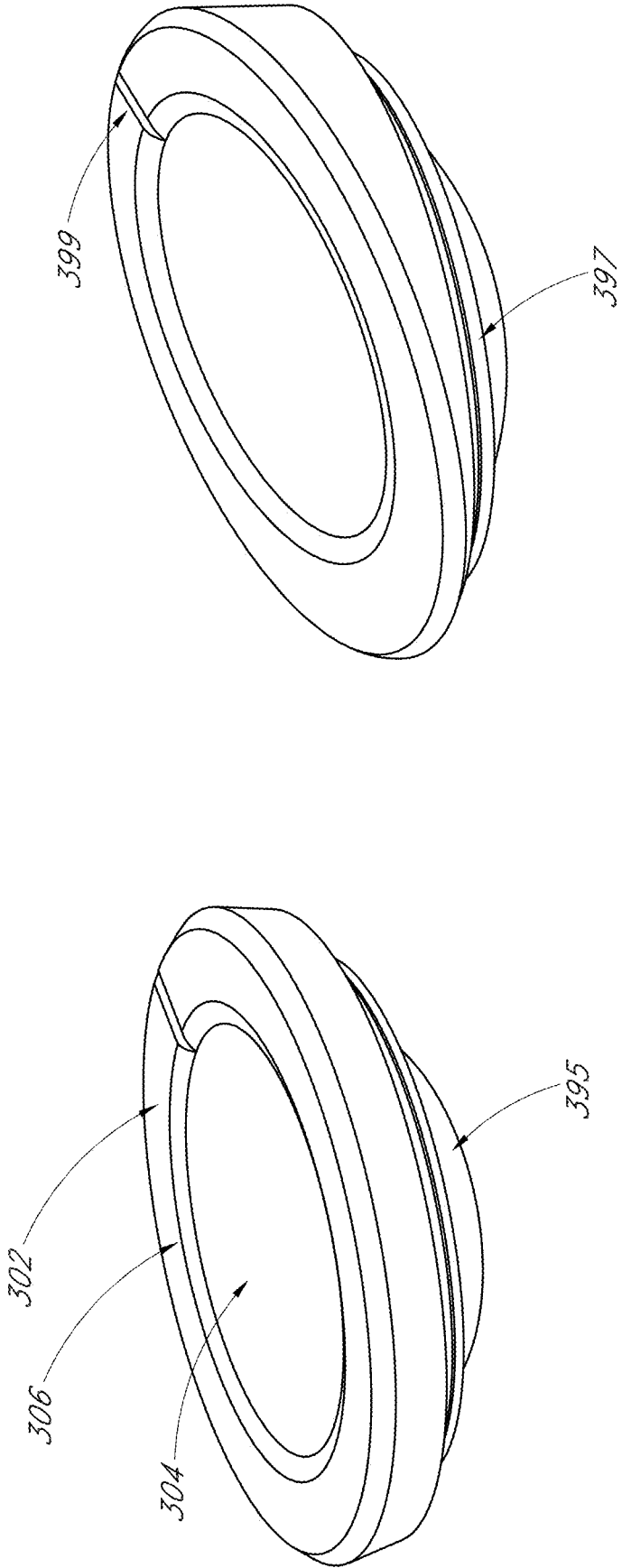

FIG. 3

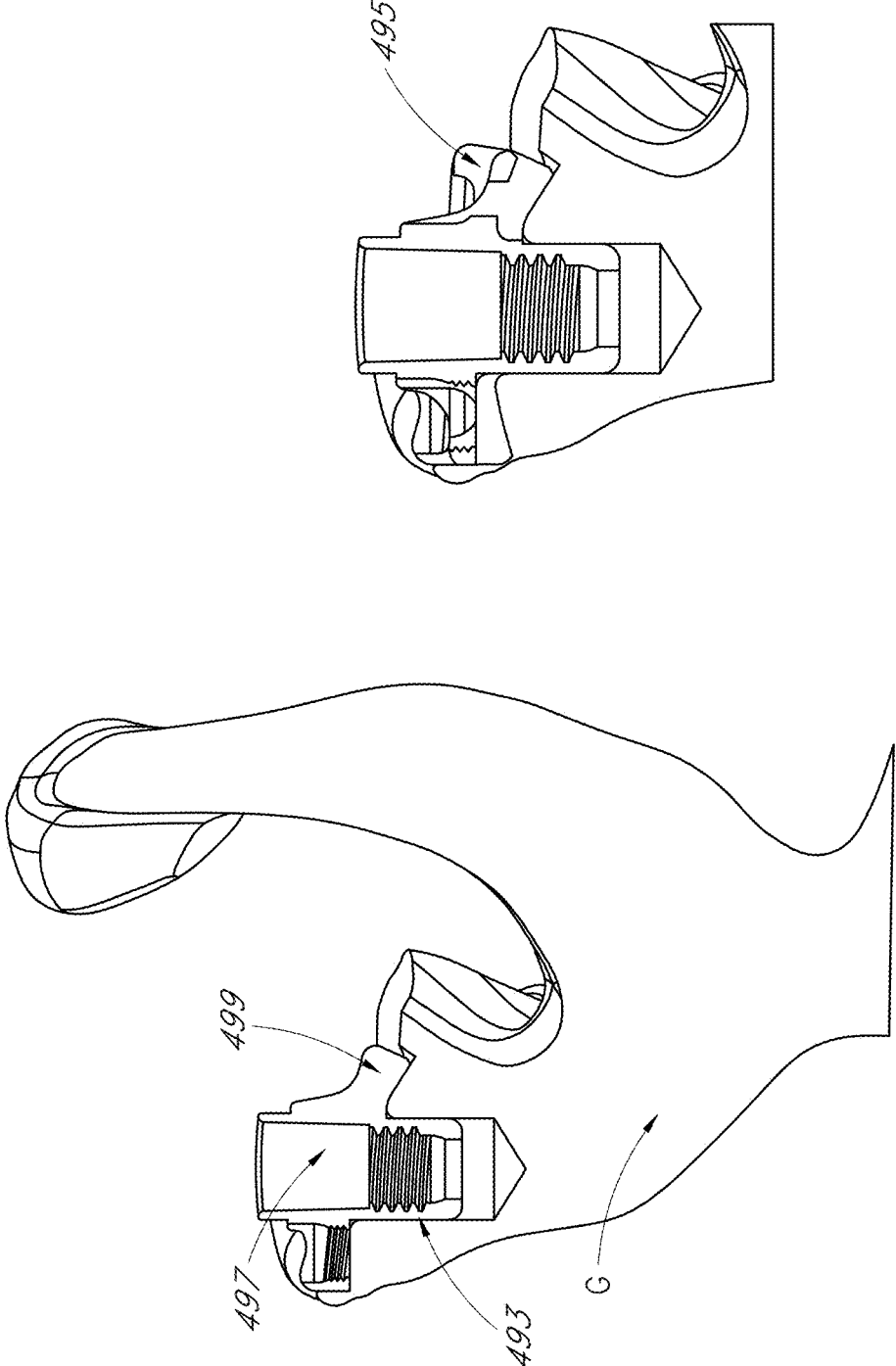

FIG. 4

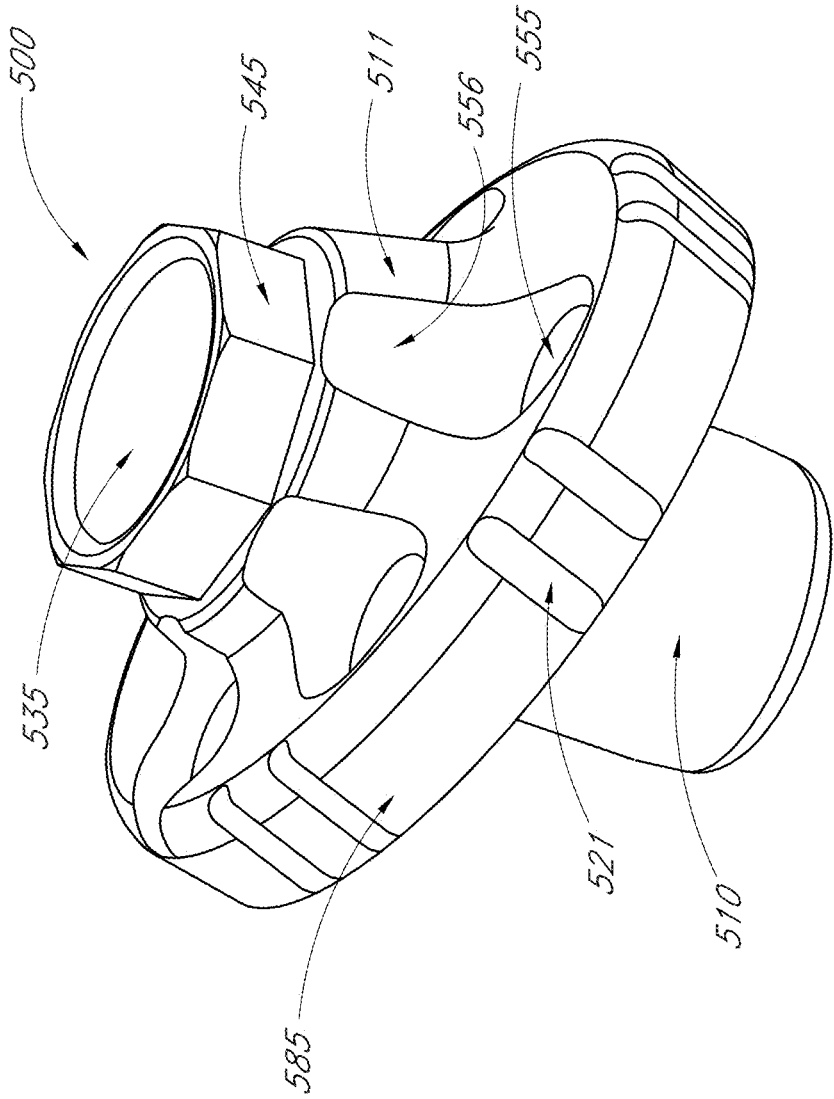

FIG. 5

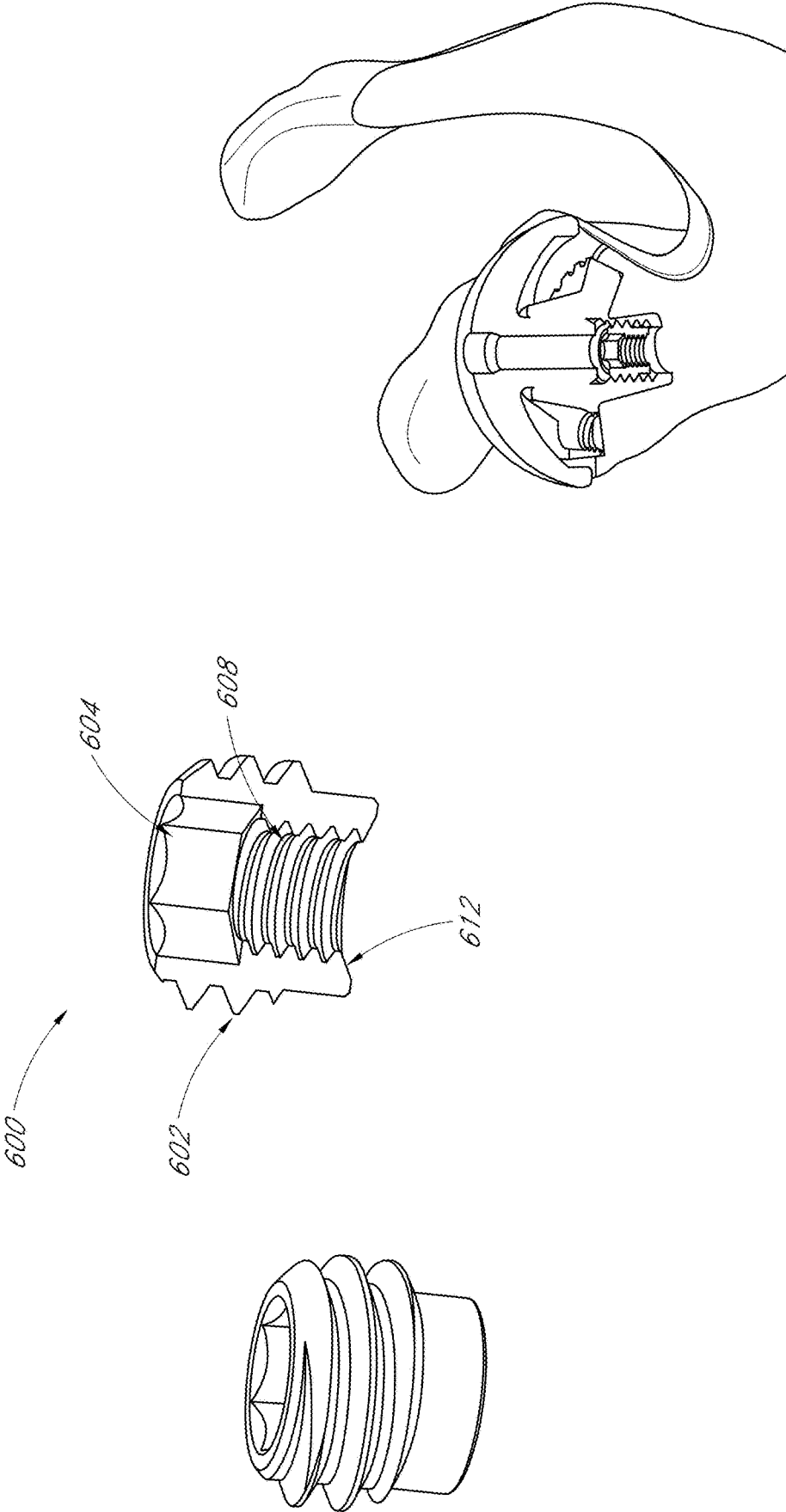

FIG. 6

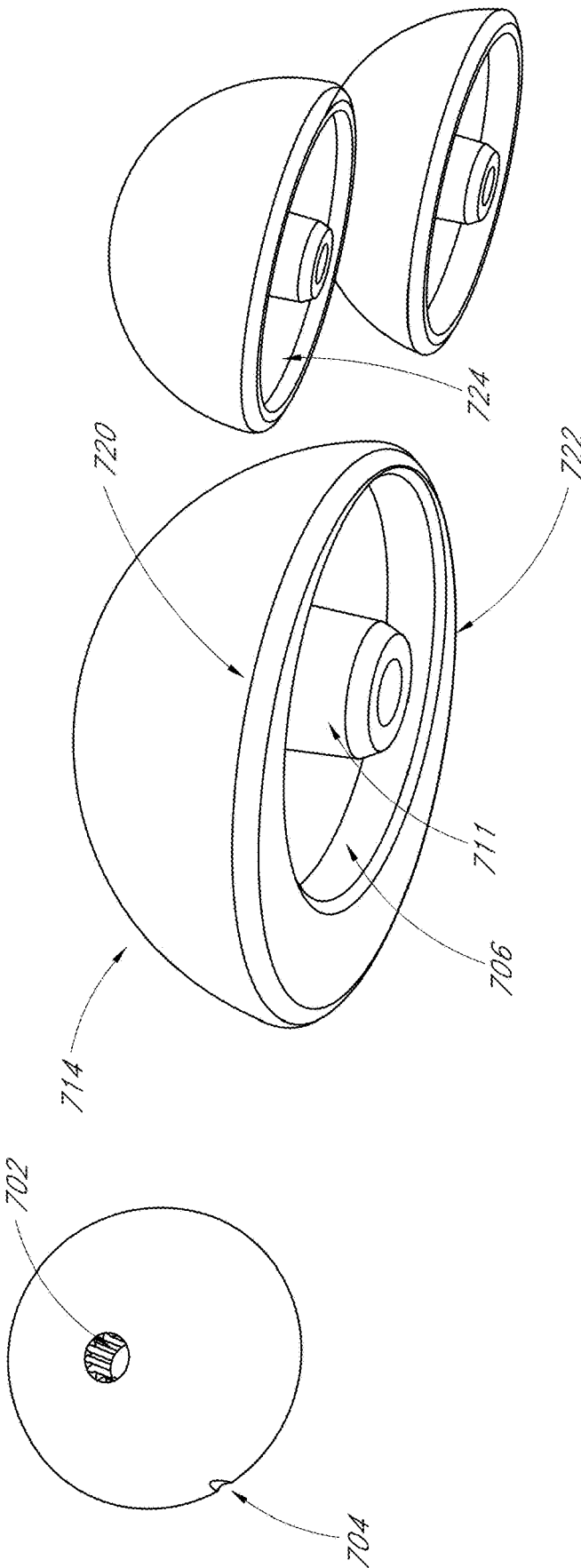

FIG. 7

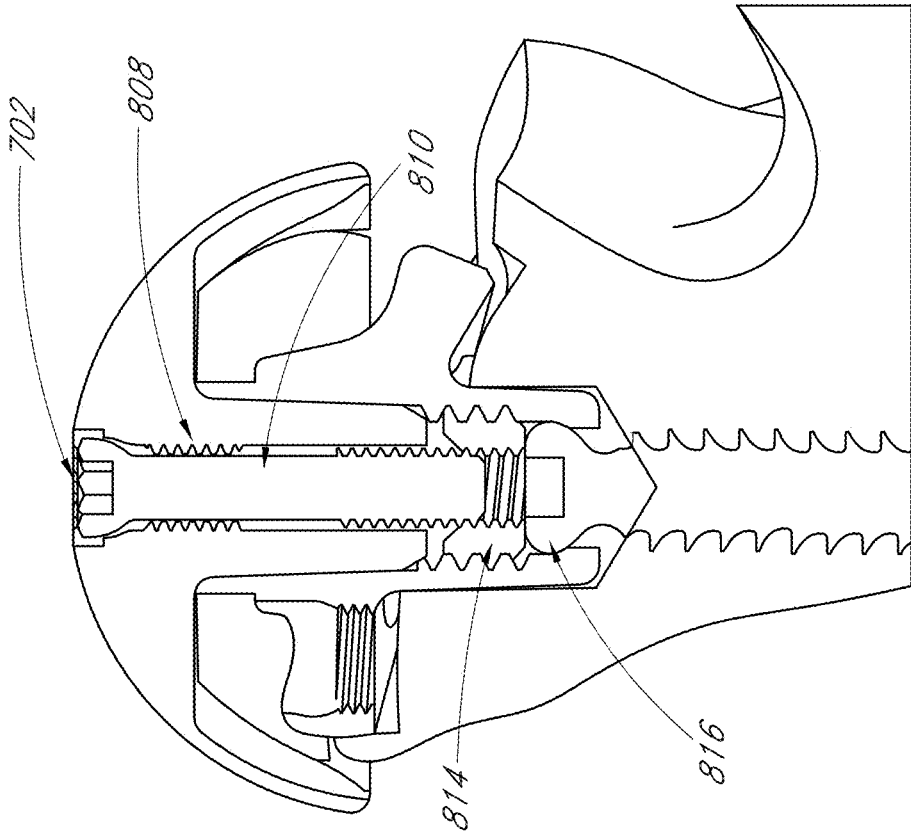

FIG. 8

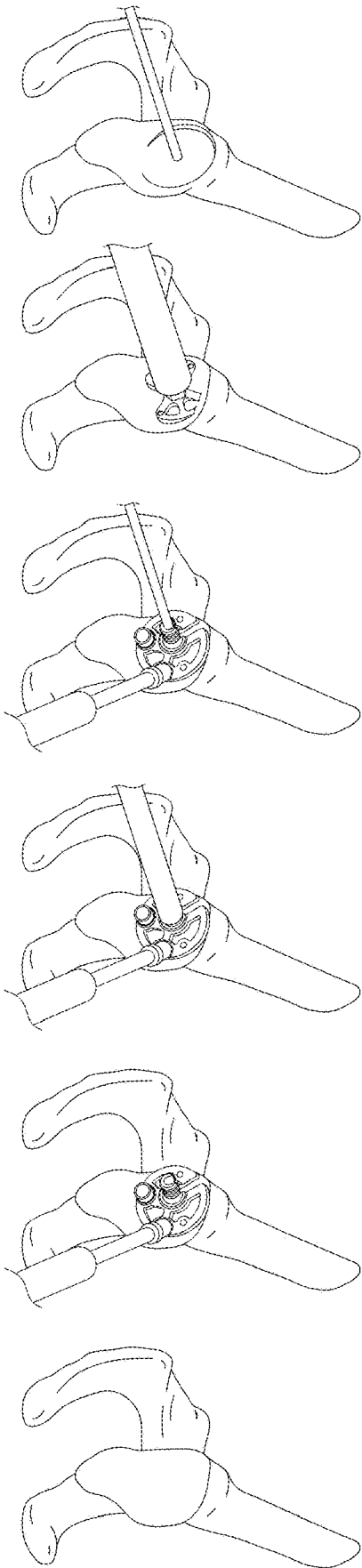

FIG. 8A FIG. 8B FIG. 8C FIG. 8D FIG. 8E FIG. 8F

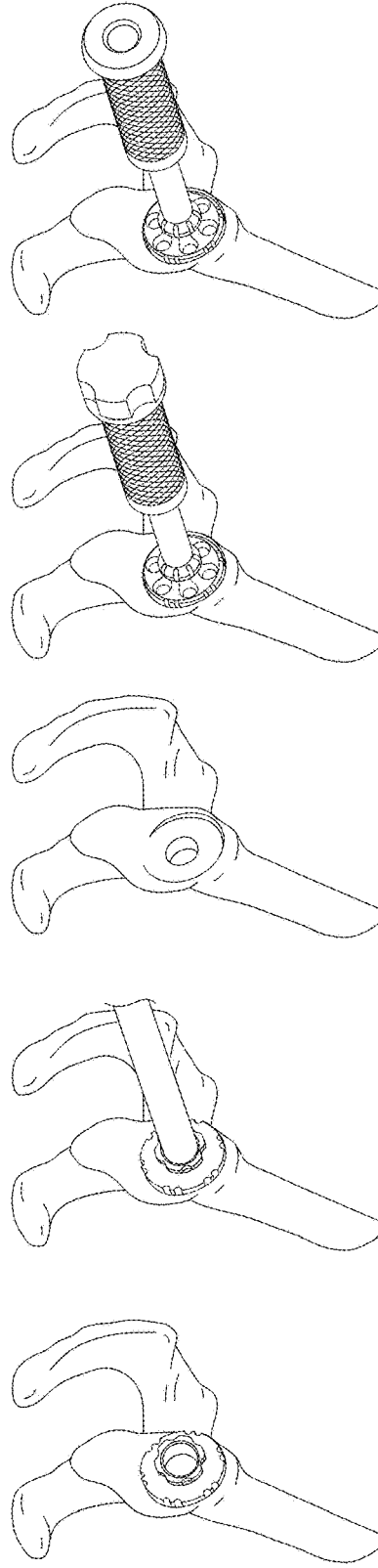

FIG. 8G FIG. 8H FIG. 8I FIG. 8J FIG. 8K

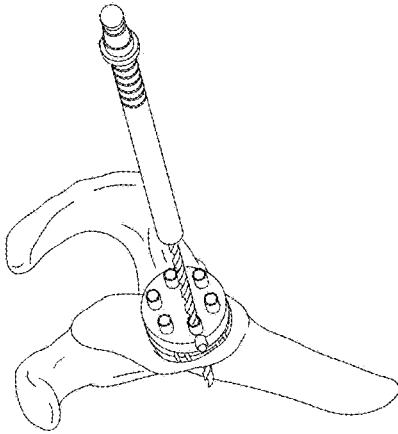

FIG. 8P

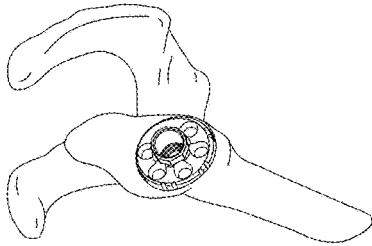

FIG. 8O

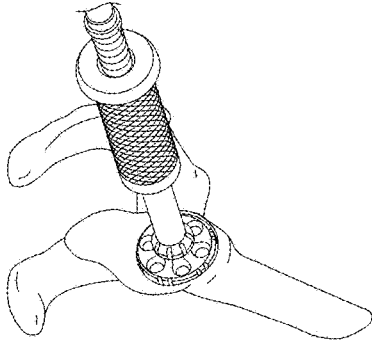

FIG. 8N

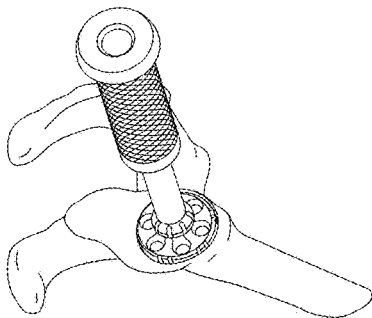

FIG. 8M

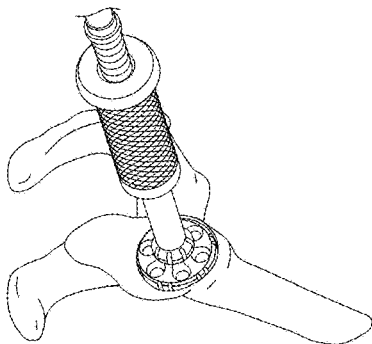

FIG. 8L

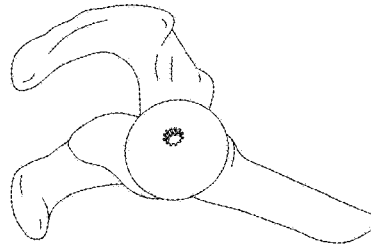

FIG. 8U

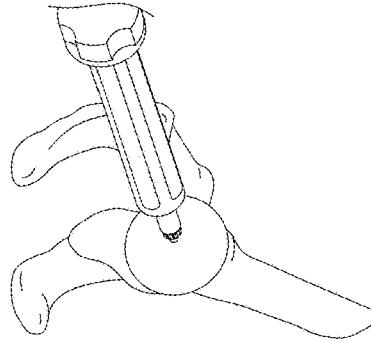

FIG. 8T

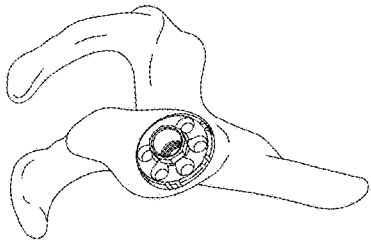

FIG. 8S

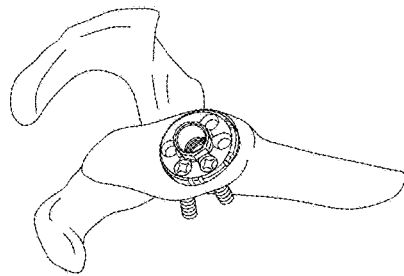

FIG. 8R

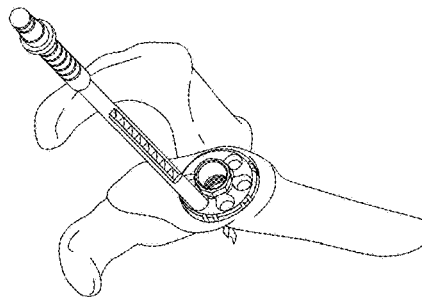

FIG. 8Q

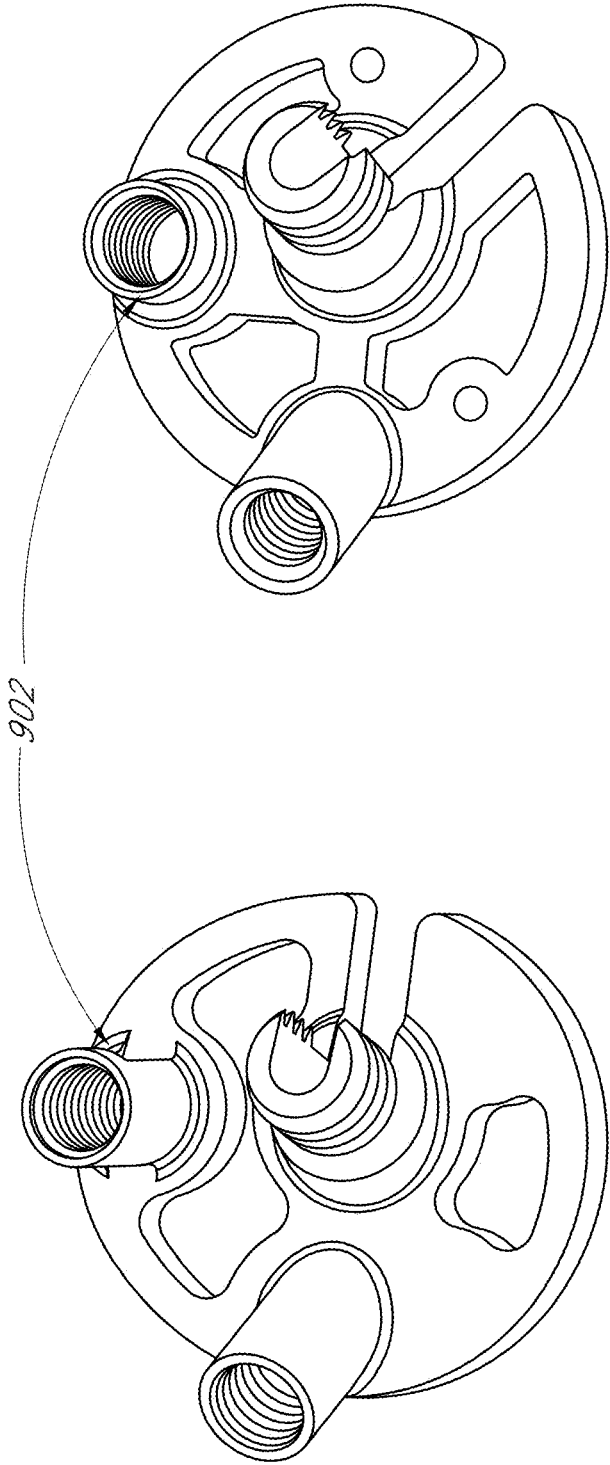

FIG. 9

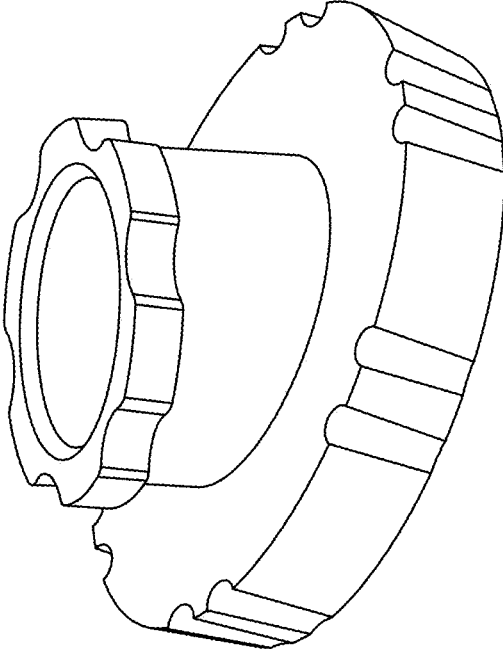
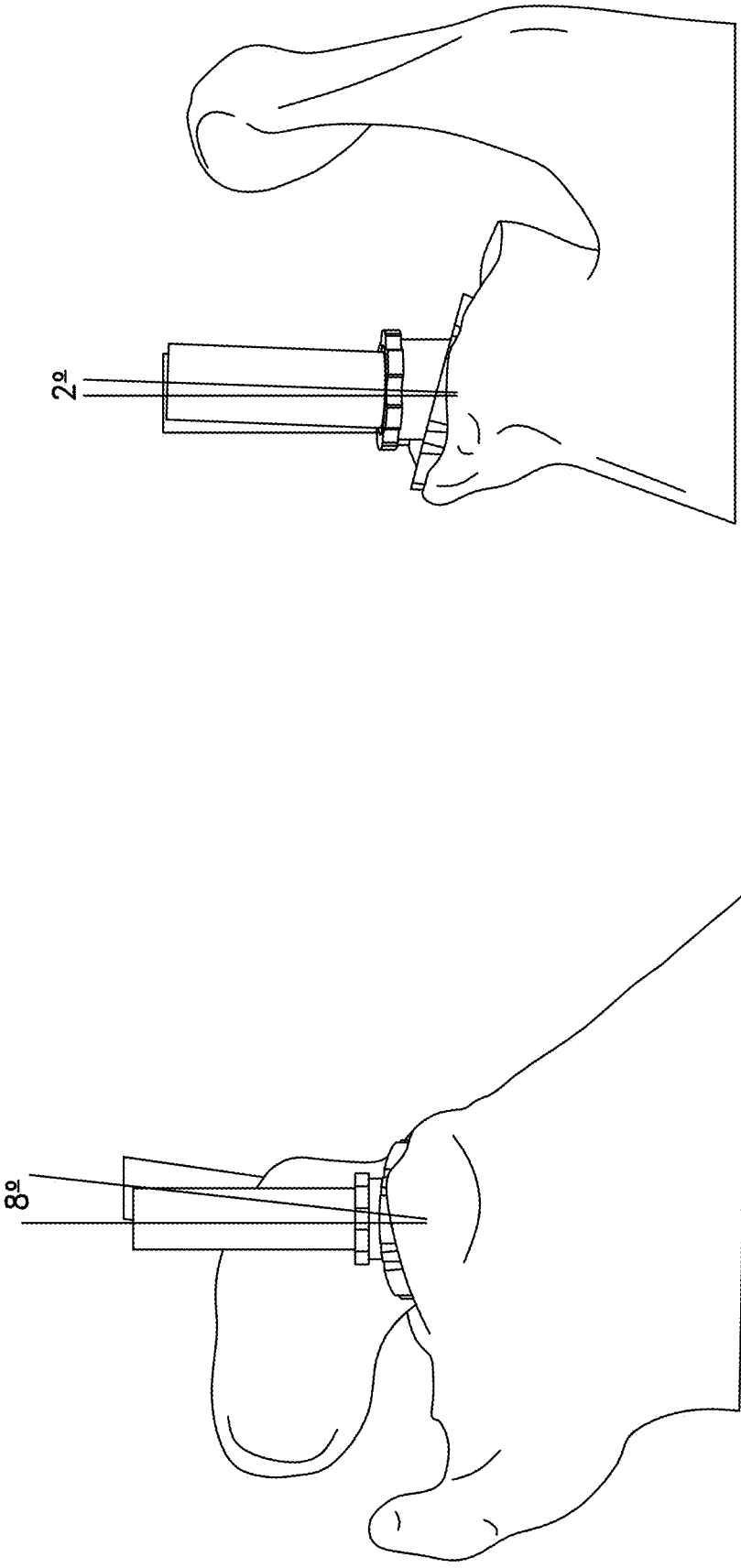

FIG. 10



Inferior-Superior View

Anterior-Posterior View

FIG. 11

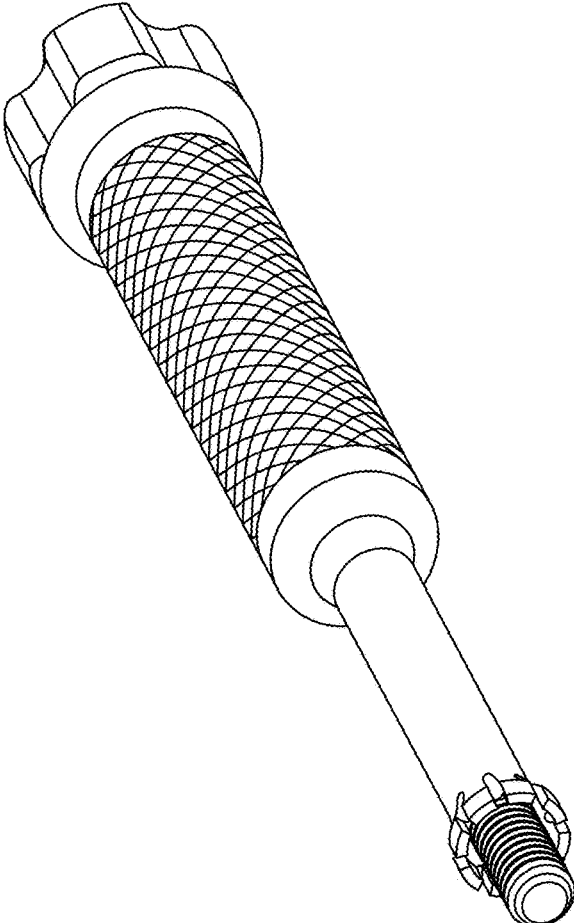
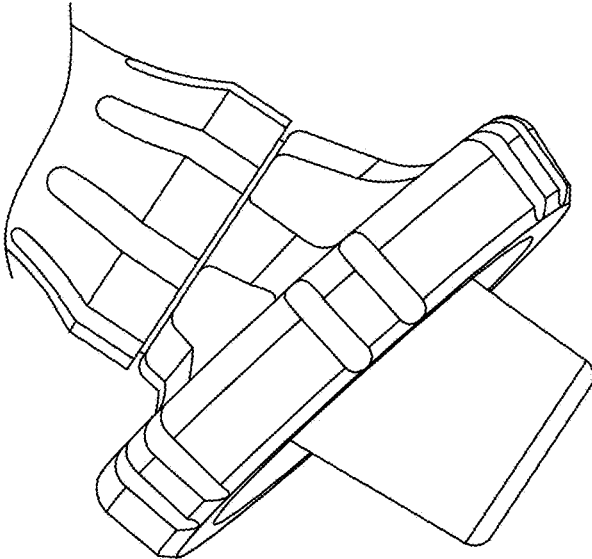

FIG. 12

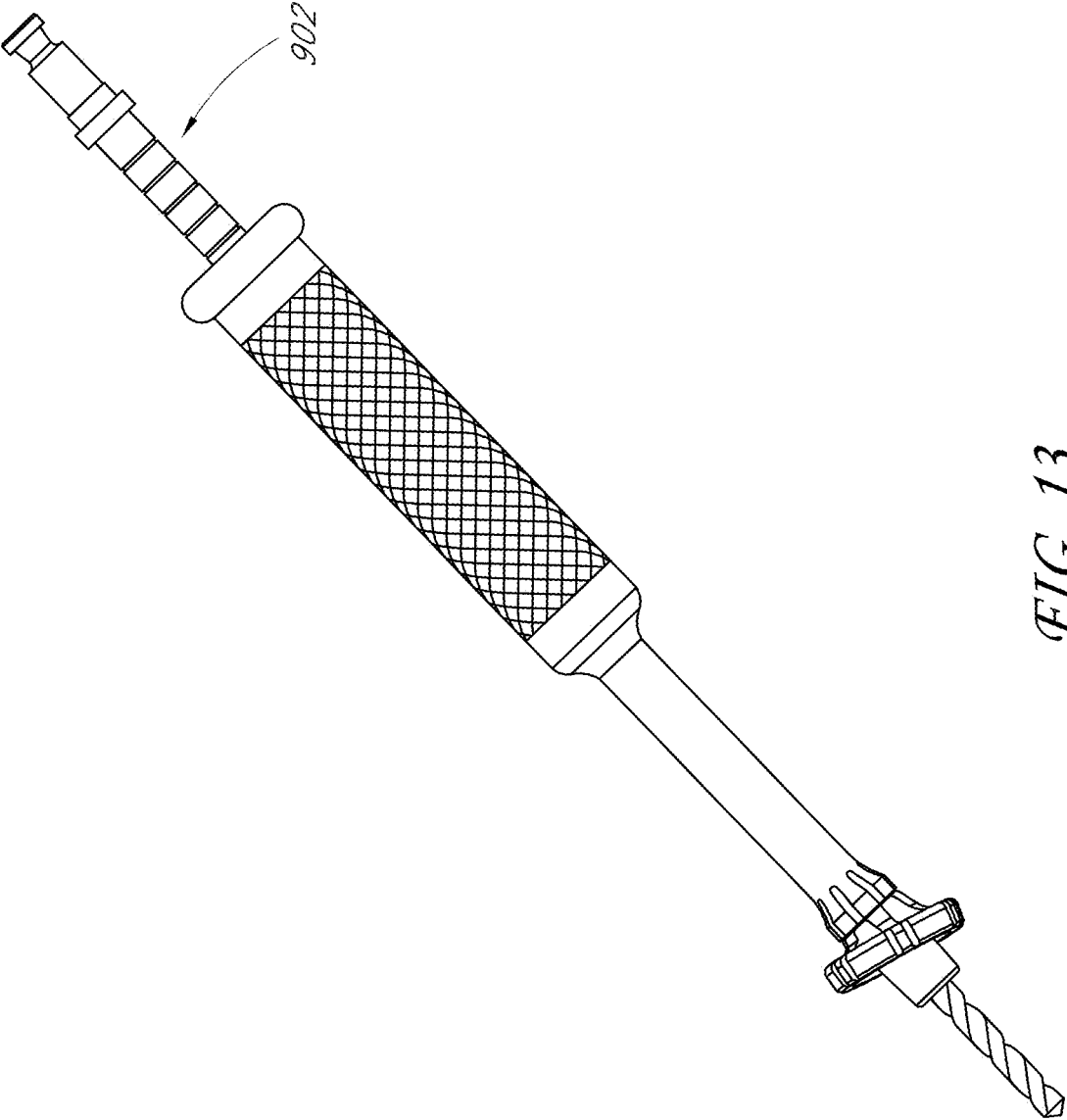

FIG. 13

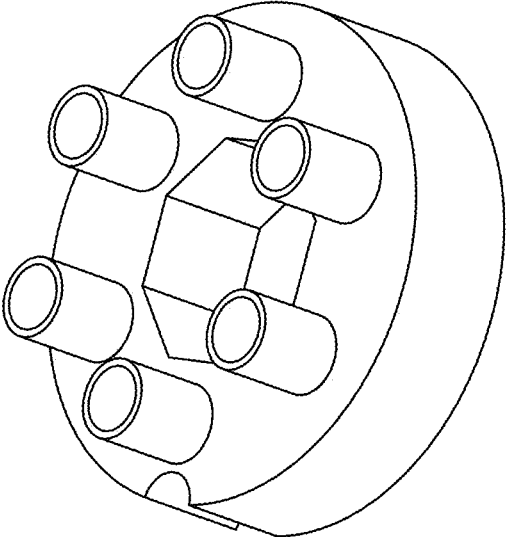
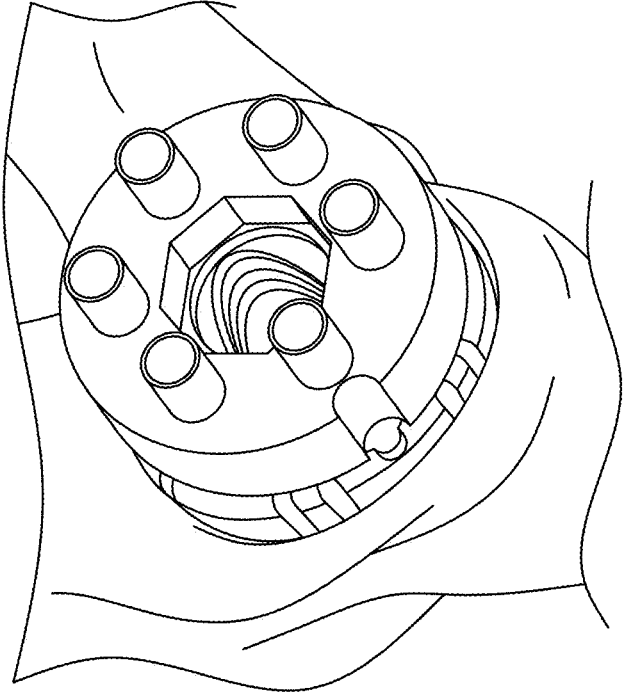

FIG. 14

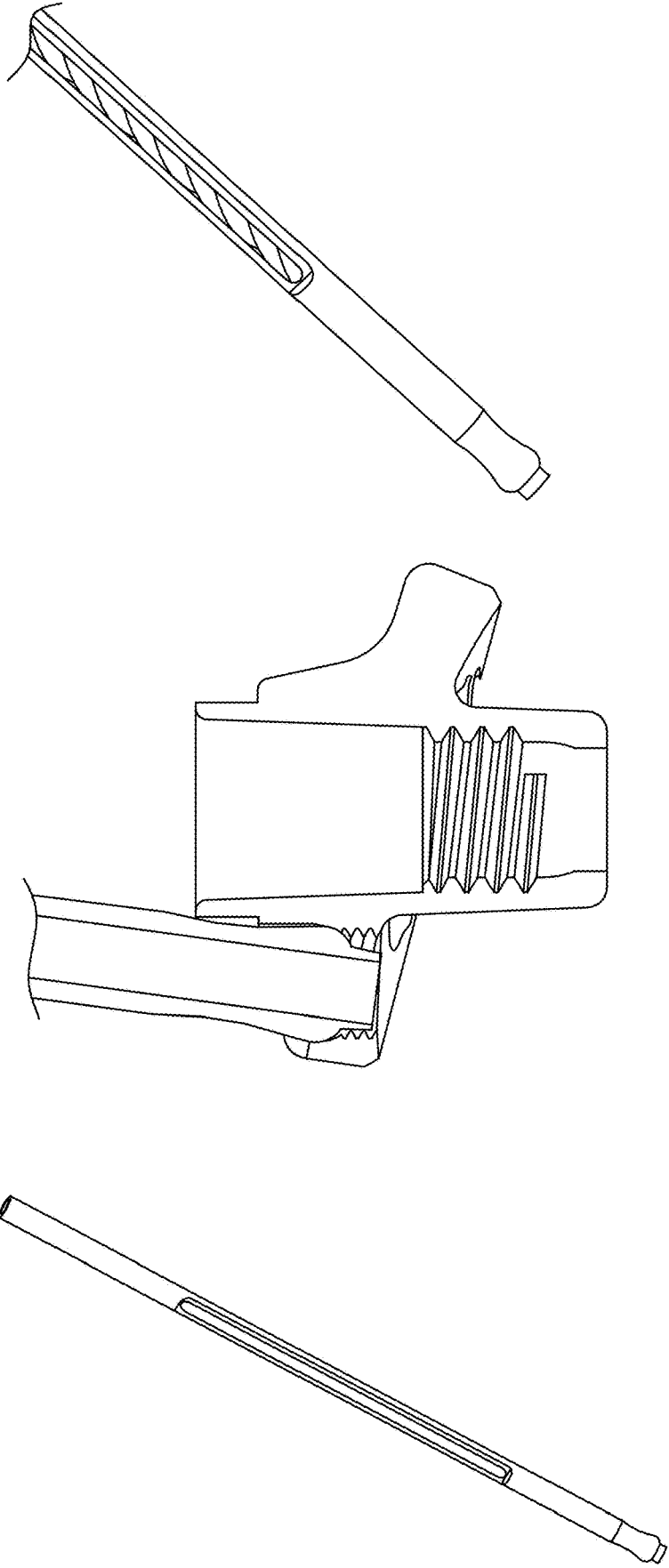

FIG. 15

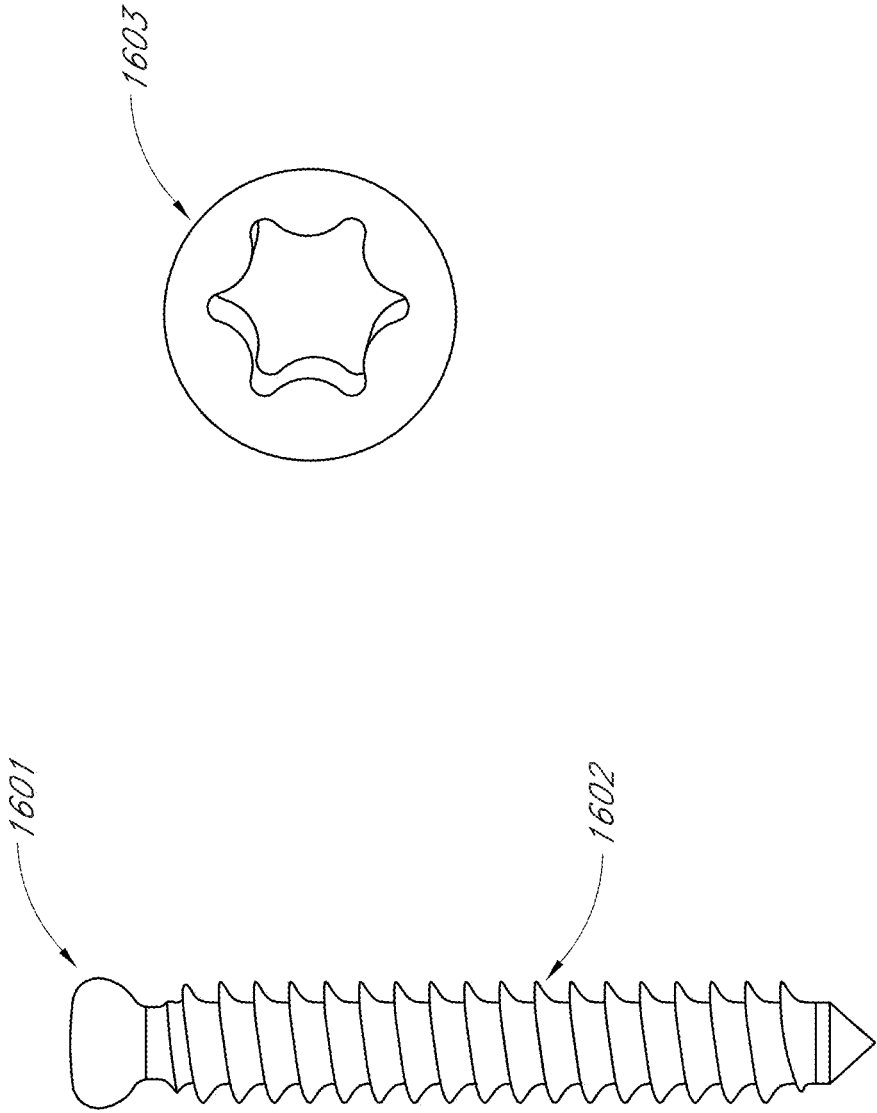

FIG. 16

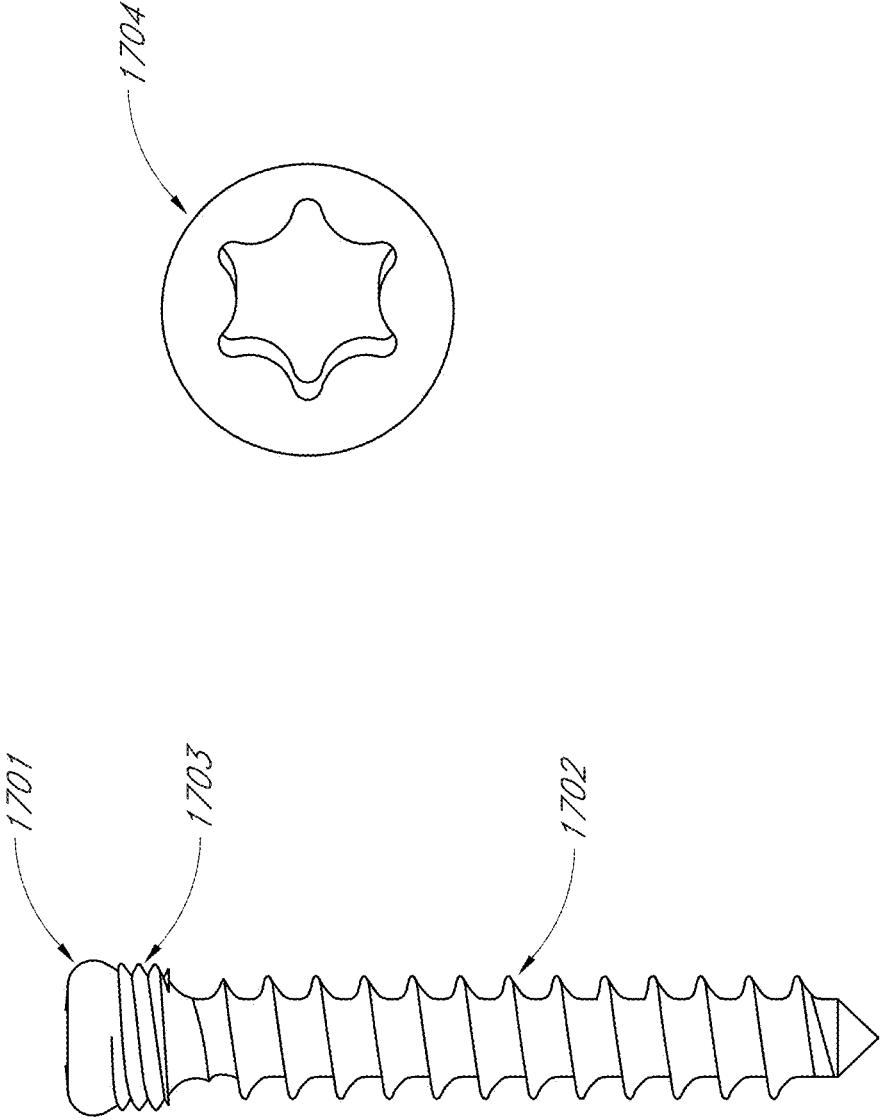

FIG. 17

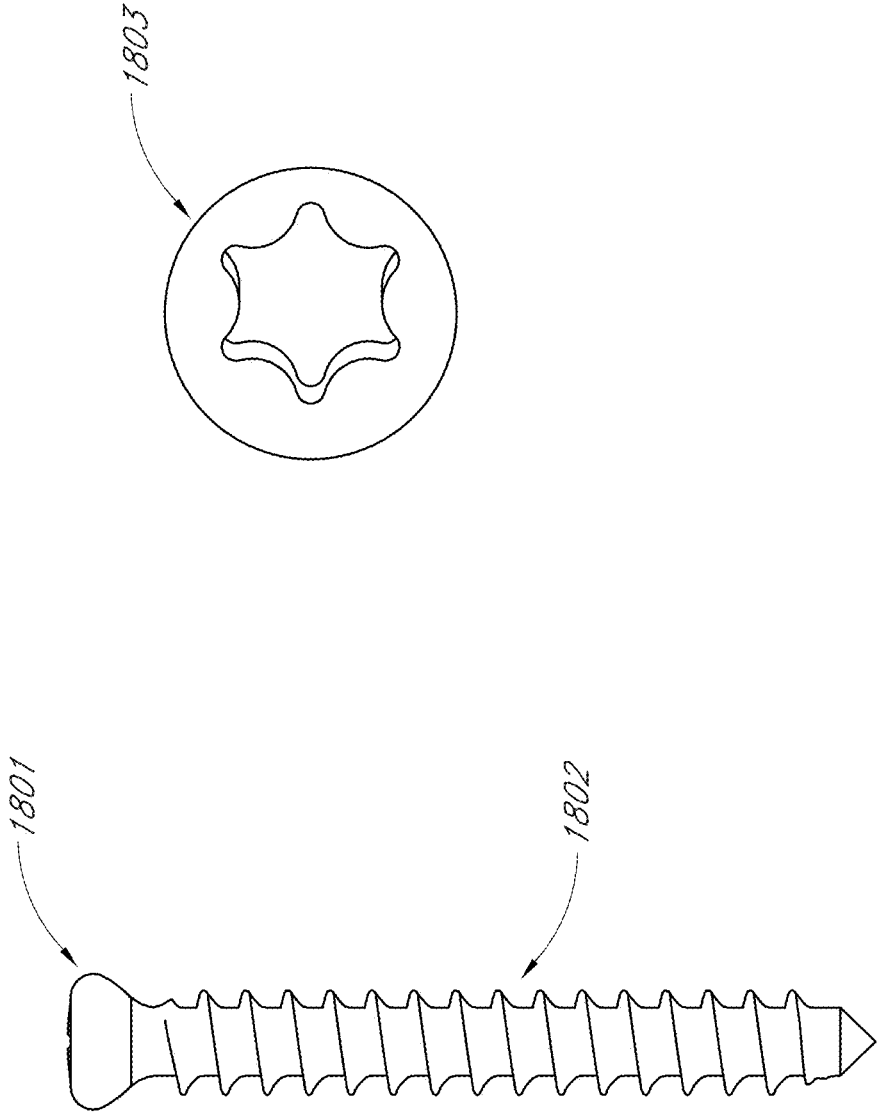

FIG. 18

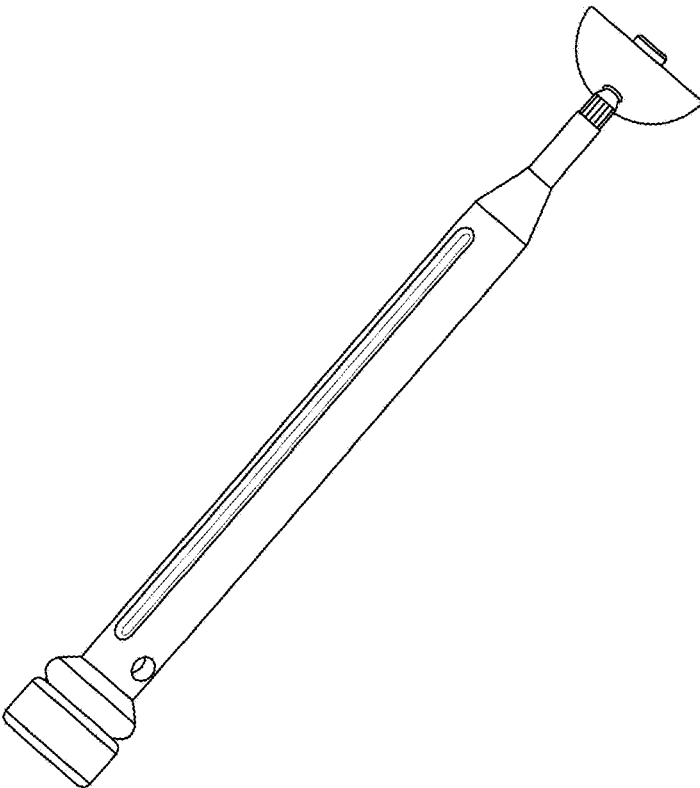
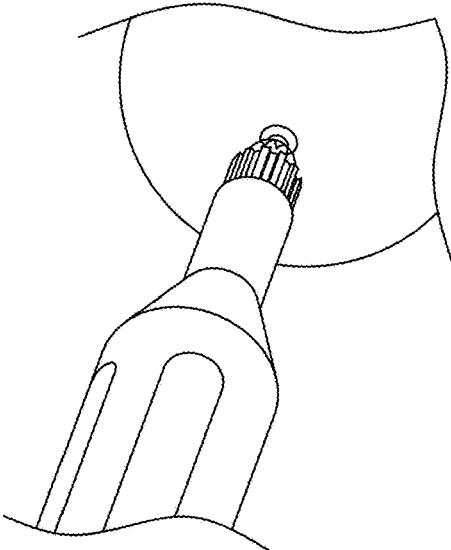

FIG. 19

TOTAL REVERSE SHOULDER SYSTEMS AND METHODS

[0001] This application is a continuation of U.S. application Ser. No. 18/477,416, filed Sep. 28, 2023, which is a continuation of U.S. application Ser. No. 18/058,058, filed Nov. 22, 2022, now U.S. Pat. No. 11,771,561, which is a continuation of U.S. application Ser. No. 17/435,333, filed Aug. 31, 2021, which is the national phase of International Application No. PCT/US2020/022094, filed Mar. 11, 2020, which claims the benefit of priority from U.S. Provisional No. 62/816,708, filed Mar. 11, 2019, which are all hereby incorporated by reference in their entireties.

BACKGROUND

[0002] Shoulder replacement is a commonly performed medical procedure for treatment of osteoarthritis, rheumatoid arthritis, as well as for treatment of certain deformities related to oncological indications as well as trauma. There are two primary types of articulations available to surgeons for treatment: anatomic and reverse. With anatomic, the surgeon replaces the articular surfaces with industrial materials such that the articulating surfaces are substantially the same shape as the natural anatomy. A stem can be commonly fixed inside the canal of the humerus, a metallic articular head can be rigidly fixed to the proximal aspect of the same, the articular head having a convex articular surface adapted to articulate with the glenoid implant. The glenoid implant can include on its back side (medial side) certain pegs or posts or fins adapted to be rigidly fixed within the glenoid fossa of the scapula and on its front side a concave or flat articular surface adapted to articulate with the humeral head of the humeral implant.

[0003] When a reverse prosthesis is used, the articular surface is reversed in that the metallic ball is rigidly fixed to the glenoid fossa of the scapula, and the concave articular surface is rigidly fixed to the humeral bone, thereby reversing the fashion of articulation of the prosthesis.

[0004] The surgeon chooses between the two types of prostheses by assessing a number of conditions of the patient including level of pain, patient activity level, deformity or severity of the bony degradation, the strength of surrounding soft tissues, and present or absence of prior surgery, and particularly the health and strength of the rotator cuff muscle and tendon. Disease of the rotator cuff is common among patients with arthritis of the shoulder. In this circumstance, it is commonly observed that the absence of insufficiency of the rotator cuff leads to a condition where the anatomic shoulder replacement prosthesis is not sufficiently stabilized by surrounding soft tissue. In this case, a reverse shoulder replacement prosthesis can be preferred in some cases due to the higher inherent stability of the articulation. In addition, the reverse prosthesis can advantageously utilize the remaining muscles in a way they can be more effective in the absence of the other soft tissue structures by adjusting the position of the articular surfaces within the joint.

SUMMARY

[0005] In some embodiments, disclosed herein is a reverse shoulder system, comprising any number of a glenoid baseplate comprising a longitudinal axis, the glenoid baseplate further comprising a stem and a central channel within a sidewall of the stem, the stem comprising a longitudinal axis. The longitudinal axis of the glenoid baseplate can be

angled with respect to the longitudinal axis of the stem, wherein the longitudinal axis of the glenoid baseplate is not perpendicular with respect to the longitudinal axis of the stem.

[0006] In some configurations, the glenoid baseplate comprises a generally disc-shaped portion extending radially outward from the central channel.

[0007] In some configurations, the stem comprises a sidewall that extends superiorly with respect to the disc portion.

[0008] In some configurations, the glenoid baseplate comprises a peripheral edge.

[0009] In some configurations, the peripheral edge comprises spaced-apart anti-rotation features.

[0010] In some configurations, the anti-rotation features comprise slots.

[0011] In some configurations, an inferior portion of the peripheral edge comprises a porous coating.

[0012] In some configurations, an inferior surface of the generally disc-shaped portion comprises a porous coating, but a superior surface does not comprise a porous coating.

[0013] In some configurations, the peripheral edge and/or an inferior surface of the baseplate comprises a conical geometry.

[0014] In some configurations, an inferior surface of the baseplate is concave.

[0015] In some configurations, the stem comprises a Morse taper lock superior to a superior-most portion of the generally disc-shaped portion of the glenoid baseplate.

[0016] In some configurations, the system further comprises a glenosphere.

[0017] In some configurations, the glenosphere comprises a superior dome-shaped surface comprising a rotational control feature configured such that an inserter tool can lock the glenosphere and the baseplate to allow for rotation of the glenosphere and the baseplate together.

[0018] In some configurations, the rotational control feature comprises a spline.

[0019] In some configurations, the system further comprises a central set screw and locking nut.

[0020] In some configurations, the system further comprises a central compression screw non-integral with the baseplate and configured for placement adjacent and distal to the central set screw.

BRIEF DESCRIPTION OF THE DRAWINGS

[0021] These drawings are illustrative embodiments and do not present all possible embodiments of this invention.

[0022] FIG. 1 illustrates an embodiment of components of a total reverse shoulder system.

[0023] FIG. 2 illustrates various embodiments of humeral trays that can be utilized with total reverse shoulder systems, according to some embodiments.

[0024] FIG. 3 illustrates a variety of humeral bearing components that can be utilized with total reverse shoulder systems, according to some embodiments.

[0025] FIG. 4 illustrates schematically an embodiment of a glenoid baseplate configured to be inset into the glenoid.

[0026] FIG. 5 illustrates schematically an embodiment of a glenoid baseplate 500 configured to be inset into the glenoid.

[0027] FIG. 6 illustrates a threaded locking insert for a central channel of a stem/post, according to some embodiments.

[0028] FIG. 7 illustrates various views of glenospheres, according to some embodiments.

[0029] FIG. 8 illustrates a schematic cross-section of a fully assembled glenosphere with a locking bolt, according to some embodiments.

[0030] FIGS. 8A-8U illustrate a glenoid surgical technique, according to some embodiments.

[0031] FIG. 9 illustrates an embodiment of a sizer/angle guide.

[0032] FIG. 10 illustrates an embodiment of a stem drill guide.

[0033] FIG. 11 schematically illustrates a stem angle change with a rotational adjustment.

[0034] FIG. 12 schematically illustrates views of a glenoid baseplate inserter (alone on the left and together with a baseplate on the right), according to some embodiments.

[0035] FIG. 13 schematically illustrates views of a calibrated central drill, according to some embodiments.

[0036] FIG. 14 schematically illustrates views of fixed angle peripheral drill guides, according to some embodiments.

[0037] FIG. 15 schematically illustrates views of variable angle peripheral drill guides, according to some embodiments.

[0038] FIG. 16 schematically illustrates side and top views of central screws, according to some embodiments.

[0039] FIG. 17 schematically illustrates side and top views of fixed angle peripheral compression screws, according to some embodiments.

[0040] FIG. 18 schematically illustrates side and top views of variable angle peripheral screws, according to some embodiments.

[0041] FIG. 19 schematically illustrates views of a glenosphere inserter, according to some embodiments.

DETAILED DESCRIPTION

[0042] In some embodiments, disclosed herein are various embodiments of a total reverse shoulder system, including a variety of humeral trays, humeral bearings, inset glenoid baseplates, threaded locking inserts, and glenospheres. Glenoid surgical techniques are also described, which can utilize various tools including but not limited to sizer/angle guides, stem drill guides, glenoid baseplate inserters, calibrated central drills, peripheral drill guides with fixed or variable angles, central screws, fixed angle peripheral compression screws, variable angle peripheral screws, and glenosphere inserters. Dimensions listed on the accompanying Figures are non-limiting examples only.

[0043] FIG. 1 illustrates an embodiment of components of a total reverse shoulder system, including a glenosphere 200 and a glenoid baseplate 102 which can be partially or completely inset in some embodiments. The glenoid baseplate 102 can be a generally disc-shaped structure and include a central aperture defining a surface of (e.g., integral with an elongate stem), or configured to fit an elongate stem or post therethrough. The glenoid baseplate 102 can include a longitudinal axis that is at an angle to a longitudinal axis of the elongate stem 100. The longitudinal axis of the glenoid baseplate 102 can be at an angle, such as generally oblique with respect to the longitudinal axis of the elongate stem 100. In some embodiments, the angle is an acute angle, and not a right angle. The angle between the two intersecting longitudinal axes of the respective baseplate 102 and the stem 100 could be, for example, about, at least about, or no

more than about 5, 10, 15, 20, 25, 30, 35, 40, 45, 50, 55, 60, 65, 70, 75, 80, 85, 90, or more or less degrees, or ranges including any two of the foregoing values.

[0044] FIG. 2 illustrates various embodiments of humeral trays that can be utilized with total reverse shoulder systems, according to some embodiments. The humeral trays can include various inner diameters IDs and outer diameters ODs, including 30 mm, 32 mm, 34 mm, 36 mm, 38 mm, 40 mm, 42 mm, or more or less IDs and/or ODs, and ranges including any two of the foregoing values. The trays can include one or more pegs, such as a central peg extending from a medial surface. The trays can be neutral, or include extensions (e.g., in thickness) that can be, for example, +2, 4, 6, 8, 10, 12 mm, or ranges including any two of the foregoing values. The trays can include various cross-sections, including oval or round cross-sections. The trays can be compatible with the same poly bearing surfaces in some cases. In some embodiments, a kit can include at least four different sizes of trays (34 mm oval neutral; 34 mm oval+6 mm extension; 38 mm round neutral; 38 mm round+6 mm extension).

[0045] FIG. 3 illustrates a variety of humeral bearing components that can be utilized with total reverse shoulder systems, according to some embodiments, including humeral trays as illustrated and described in connection with FIG. 2. The bearing components can include, for example, a peripheral ring 302 and a central recessed portion that can be outlined radially outwardly by an inner edge of the peripheral ring, and an inner bowl-shaped portion 304. The peripheral ring can include indicia, such as a slot or other marking 399 illustrating the highest point of the bearing component. Also illustrated is the recessed poly dome 395, and a partial or full annular barb 397 around the outer circumference of the bearing component. The bearing component can include a variety of geometries include neutral, 1, 2, 3, 4, 5, 6, 7, 8, 9, 10, 11, 12, 13, 14, 15, 16, 17, 18, 19, 20 degree angles to horizontal, or ranges including any two of the foregoing values. In some embodiments, the bearing component does not change the joint center. In some embodiments, the bearing component can include 30, 31, 32, 33, 34, 35, 36, 37, 38, 39, 40, 41, 42, 43, 44, 45 mm, or more or less spherical diameters, or ranges including any two of the foregoing values. In some embodiments, systems and methods can include an offset of 1, 2, 3, 4, 5, 6, 7, 8, 9, or 10 mm, or ranges including any two of the foregoing values.

[0046] FIG. 4 illustrates schematically an embodiment of a glenoid baseplate configured to be inset into the glenoid G as illustrated. The longitudinal axis of the baseplate can be angled with respect to the longitudinal axis of the stem/post as described, for example, with respect to FIG. 1, and can include a version change 499 to compensate for posterior bony defects. In some embodiments, the glenoid baseplate includes a central channel therethrough defining a surface of (e.g., integral with an elongate stem), or configured to fit configured to house a stem/post as shown. The glenoid baseplate can include a generally conical shape with a concave undersurface configured to rest within a reamed surface of glenoid bone, which advantageously allows for a single rotary reamer to be utilized, in contrast to conventional glenoid baseplates with flat undersurfaces that require a two-step reaming process. The post 493 can have a length of about, at least about, or no more than about 5, 5.5, 6, 6.5, 7, 7.5, 8, 8.5, 9, 9.5, 10, 10.5, 11, 11.5, 12, 12.5, 13, 13.5, 14, 14.5, 15 mm or more or less, or ranges including any two

of the foregoing values. In some embodiments, the central channel and/or stem can include a female Morse taper **497** of about 1, 2, 3, 4, 5, 6, 7, 8, 9, 10, or more or less degrees, including ranges incorporating any two of the foregoing values. As shown in the right illustration of FIG. 4, the baseplate can be configured to pivot around the stem/taper at arrow **495** for version correction and to allow for a direct bone-implant interface without requiring augmentation. In some embodiments, the system can be configured to provide version angle corrections of, for example, about 0, 2.5, 5, 7.5, 10, 12.5, 15, 17.5, 20 degrees or more or less, or ranges including any two of the foregoing values. In some embodiments, the baseplate could have a diameter of about, at least about, or no more than about 18, 19, 20, 21, 22, 23, 24, 25, 26, 27, 28, 29, 30, 31, 32, 33, 34, 35, 36, 37, 38, 39, 40 mm, or more or less, or ranges including any two of the foregoing values. The baseplate can advantageously pivot around the central stem with a Morse taper for version correction and allows for a direct bone-implant interface.

[0047] FIG. 5 illustrates schematically an embodiment of a glenoid baseplate **500** configured to be inset into the glenoid (not shown in FIG. 5). The longitudinal axis of the baseplate **500** can be angled with respect to the longitudinal axis of the stem/post **510** as described, for example, with respect to FIGS. 1 and 4 above. The baseplate **500** could have a generally arcuate peripheral edge. The peripheral edge could include spaced-apart anti-rotational slots **521** directed generally transverse to a longitudinal plane of the baseplate **500**. In some embodiments, the peripheral edge of the baseplate **500** can taper (e.g., decrease) in diameter from a superior to inferior dimension. A central channel can extend through the baseplate **500**, as well as include a superiorly-extending sidewall or lip **511** somewhat similar to the side slopes of a volcano. The central channel can define a surface of (e.g., integral with an elongate stem), or configured to fit be configured to house the stem/post **510** therethrough. The baseplate **500** can also include a plurality of regularly or irregularly spaced-apart secondary (peripheral) channels **555** spaced radially outward from the central channel of the baseplate and configured to house fixed and variable angle screws therethrough. The secondary channels **555** can be asymmetric and include superiorly-extending portions **556** that can extend into and interrupt the superiorly-extending sidewall or lip **511** of the central channel of the baseplate **500**. The baseplate **500** can include a porous coating **585** on the entire, or only a part of the peripheral edge and/or an inferior surface (e.g., undersurface) of the baseplate **500** to promote bone ingrowth, for example.

[0048] Still referring to FIG. 5, the stem/post **510** could have an internal taper, such as a Morse taper, of about, at least about, or no more than about 1, 2, 3, 4, 5, 6, 7, 8, 9, 10, 11, 12, 13, 14, 15 degrees, or more or less, or ranges including any two of the foregoing values. The stem/post **510** can also include a rotational control feature **545** along an outer diameter of the stem/post **510**, and in some embodiments superiorly with respect to the uppermost surface of the sidewall **511** of the central channel of the glenoid baseplate **500** as shown. The rotational control feature **545** could be non-circular or non-arcuate, such as a hexagonal shape as shown for example. The stem/post **510** can also include a central channel and include a Morse taper lock **535** configured to mate with a glenosphere (not shown). The Morse taper lock can extend superiorly with respect to the uppermost surface of the sidewall **511** of the central channel

of the glenoid baseplate **500**. The central channel of the stem/post **510** can be configured to house a primary screw (not shown) therethrough, which can be a variable angle primary screw, and optionally locking.

[0049] FIG. 6 illustrates a threaded locking insert **600** for a central channel of a stem/post, according to some embodiments. The insert **600** can include an outer male thread **602** and configured to go into the central channel of a baseplate. The outer diameter of the insert can also include a hexagonal geometry portion **604** at the superior end, of about, at least about, or no more than about 1, 2, 3, 4, 5, 6, 7, 8, 9, 10 mm or more or less, or ranges including any two of the foregoing values. The hexagonal geometry portion **604** can be configured to serve as a rotational control feature in some embodiments. The insert **600** can also include a female thread **608** configured to receive a supplemental glenosphere locking screw (not shown), and a spherical surface **612**, for example, at its inferior end to lock a variable angle screw.

[0050] FIG. 7 illustrates various views of glenospheres, according to some embodiments. The left image illustrates a glenosphere with a rotational control feature **702**, which can include a spline, such as an asymmetric spline, and configured to advantageously allow for rotational control about the spline and allow an inserter tool to lock and rotate the glenosphere together with another component, such as a baseplate. The glenosphere can also include one or more indicia, such as an eccentric rotational mark **704**. The glenosphere can include a generally dome-shaped surface **714**, a cavity **706** with an inferior-facing opening **708**, and a hollow post including a morse taper lock **711** into the baseplate. The glenosphere could be a full hemisphere, or short of a full hemisphere by a distance **720** of about, at least about, or no more than about 0.5 mm, 0.75 mm, 1 mm, 1.25 mm, 1.5 mm, 1.75 mm, 2 mm, 2.25 mm, 2.5 mm, 2.75 mm, 3 mm, or more or less, or ranges including any two of the foregoing values.

[0051] Still referring to FIG. 7, in some embodiments, the glenosphere can include an articulating diameter of about, at least about, or no more than about 25, 26, 27, 28, 29, 30, 31, 32, 33, 34, 35, 36, 37, 38, 39, 40, 41, 42, 43, 44, 45, 46, 47, 48, 49, 50 mm, or more or less, or ranges including any two of the foregoing values. In some embodiments, systems and methods can include an offset and/or eccentric dimension of 1, 2, 3, 4, 5, 6, 7, 8, 9, or 10 mm, or ranges including any two of the foregoing values. In some embodiments, the glenosphere has a neutral geometry. In some embodiments, a glenosphere **724** is offset by about +3 mm or about 6 mm, for example. In some embodiments, a glenosphere **722** has an eccentric dimension of between about 2 mm and about 4 mm. In some embodiments, a secondary locking screw can be utilized together with the glenosphere.

[0052] FIG. 8 illustrates a schematic cross-section of a fully assembled glenosphere with a locking bolt, according to some embodiments, along with the baseplate. The glenosphere can include a central channel therethrough including a rotational control feature **702** at, for example, a superior-most portion that can be as described elsewhere herein. The central channel can also include a threaded surface **808** for an inserter/head extractor, such as inferior to the rotational control feature **702**, and optionally be configured to accommodate a secondary locking screw at **810**, to push and/or rotate with the post of the baseplate. A post of the glenosphere can be placed at least partially within a central channel of the baseplate as illustrated. A central set screw/

locking nut **814** can be connected to, and in some cases removably attachable to a central channel, e.g., of the glenoid baseplate, and have an end adjacent or directly touching an end of a central compression screw **816**, which can include a diameter of, for example, of about, at least about, or no more than about 4, 4.5, 5, 5.5, 6, 6.5, 7, 7.5, 8, 8.5, 9, 9.5, 10 mm, or more or less, or ranges including any two of the foregoing values. The central compression screw can be configured to angulate with respect to the baseplate, and advantageously allow for the use of a locking screw.

[0053] FIGS. **8A-8U** illustrate a glenoid surgical technique, according to some embodiments, which can include any number of the following actions. FIG. **8A** illustrates a glenoid surface with an A3-E3 defect. A sizer/angle guide can be placed as in FIG. **8B**. A wire guide/wire can be placed in FIG. **8C**. The wire guide and sizer/angle guide can be removed, as in FIG. **8D**. The glenoid surface can then be reamed for the baseplate, as in FIGS. **8E** and **8F**. The stem drill guide can then be placed and adjusted in FIG. **8G**. A hole for a stem can then be drilled in FIGS. **8H** and **8I**. The baseplate can then be inserted, as shown in FIG. **8J**, and the threaded rod removed, as shown in FIG. **8K**. A central cavity can be drilled, and the length of a central screw to be placed determined, in FIG. **8L**. The drill can be removed in FIG. **8M**, and the screw and screwdriver placed through the shaft, and the screw tightened in FIG. **8N**. The baseplate inserter handle can be removed in FIG. **8O**, and holes can be drilled for the peripheral locking screws in FIG. **8P**. Holes can be drilled for variable angle screws, as shown in FIG. **8Q**. The peripheral screws can be inserted and tightened in FIG. **8R**. The central set screws and secondary locking nuts can be inserted and tightened in FIG. **8S**. The glenosphere can be inserted in FIG. **8T**, and the locking bolt inserted and tightened in FIG. **8U**.

[0054] FIG. **9** illustrates an embodiment of a sizer/angle guide including an inferior tilt mechanism **902**. The mechanism could be fixed to a set angle (e.g., about 0, 5, 10, 15, 20, 25 degrees, or ranges including any two of the foregoing values), or adjustable in some embodiments. The mechanism could be round or oval shaped in some embodiments, and include a slot (e.g., posterior or posterior inferior) to allow for removal. The inferior tilt mechanism **902** could include a set screw with a calibrated window, or individual depth screws in some cases.

[0055] FIG. **10** illustrates an embodiment of a stem drill guide, that can include a diameter of about, at least about, or no more than about 18, 19, 20, 21, 22, 23, 24, 25, 26, 27, 28, 29, 30, 31, 32, 33, 34, 35, 36, 37, 38, 39, 40 mm or more or less, or ranges including any two of the foregoing values. The drill guide could include a version angle of, for example, about 0, 5, 10, 15, 20, 25 degrees or more or less, or ranges including any two of the foregoing values. In some embodiments, the larger the version angle, the more stem tilt is generated as rotation occurs.

[0056] FIG. **11** schematically illustrates a stem angle change with a rotational adjustment (e.g., about 30 degrees), and an angled version plate (e.g., about 15 degrees) as a non-limiting example. Anterior-posterior and inferior-superior views are illustrated.

[0057] FIG. **12** schematically illustrates views of a glenoid baseplate inserter (alone on the left and together with a baseplate on the right), according to some embodiments. The baseplate inserter can be configured for any number of: positive rotational control; slim design to allow visualization

through screw holes to know when seated; and/or a multi-function handle allows for drilling central screw hole, and inserting a central screw.

[0058] FIG. **13** schematically illustrates views of a calibrated central drill, according to some embodiments. Calibrated marks/indicia **902** at spaced-apart desired increments (e.g., 5 mm increments in some embodiments) near the proximal end of the instrument can help to determine the length of a central screw that may be needed. The calibration length can start at, for example, about, at least about, or no more than about 15 mm, 20 mm, 25 mm, 30 mm, 35 mm, 40 mm, or more or less, including any two of the foregoing values and may advantageously allow for a surgical step to be cut out.

[0059] FIG. **14** schematically illustrates views of fixed angle peripheral drill guides, according to some embodiments. The drill guides can be configured to fit over a geometry, such as a polygonal shaped portion (e.g., octagon) on the top of the baseplate, and the operator can then determine which fixed angle screws to drill.

[0060] FIG. **15** schematically illustrates views of variable angle peripheral drill guides, according to some embodiments.

[0061] FIG. **16** schematically illustrates side and top views of central screws, according to some embodiments, including a head **1601**, threaded shaft **1602**, and distal tapered portion. In one embodiment, the screw can have a 6.5 mm head, and 6 mm threaded shaft, although various size ranges and increments are possible, including about, at least about, or no more than about 3, 3.5, 4, 4.5, 5, 5.5, 6, 6.5, 7, 7.5, 8, 8.5, 9, 9.5, 10 mm, or more or less head and/or threaded shaft diameters, or ranges including any two of the foregoing values. In some embodiments, a central screw can include a total or working length of about, at least about, or no more than about 10, 11, 12, 13, 14, 15, 20, 25, 30, 35, 40, 45, 50, 55, 60, 65, 70 mm, or more or less, or ranges including any two of the foregoing values. In some embodiments, anodization of the screw can optionally be present to help differentiate the screws. The screw head could have various internal feature geometries **1603**, including a T20 hexalobe configuration in some embodiments.

[0062] FIG. **17** schematically illustrates side and top views of fixed angle peripheral compression screws, according to some embodiments, including a head **1701**, double-lead thread **1703** proximal to a threaded shaft **1702**, and distal tapered portion. The screws can be various size ranges and increments, and include T20 hexalobe or other internal head feature geometries **1704** as described elsewhere herein. In one embodiment, the head could be about 5.7 mm in diameter, with a 4.5 mm threaded shaft diameter, or dimensions listed elsewhere herein, such as in connection with FIG. **16** for example.

[0063] FIG. **18** schematically illustrates side and top views of variable angle peripheral screws, according to some embodiments, including a head **1801**, threaded shaft **1802**, and distal tapered portion. The screws can be various size ranges and increments, and include T20 hexalobe or other internal head feature geometries **1803** as described elsewhere herein. In one embodiment, the head could be about 5.7 mm in diameter, with a 4.5 mm threaded shaft diameter, or dimensions listed elsewhere herein, such as in connection with FIG. **16** or **17** for example.

[0064] FIG. **19** schematically illustrates views of a glenosphere inserter, according to some embodiments, which can

include a distal end with a feature complementary to a spline on the glenosphere, such as described in connection with FIG. 7, for example. The glenosphere inserter can be configured to, for example, advantageously provide positive attachment to the glenosphere; allow for solid rotational control while inserting; and/or may involve a secondary impaction step after removal.

[0065] In some embodiments, embodiments of the invention can be used or modified with use with particular advantages of using inset glenoid fixation technology in anatomic shoulder arthroplasty, such as described, for example, in U.S. Pat. Nos. 8,007,538 and/or 8,778,028 to Gunther, which are hereby incorporated by reference in their entireties. Furthermore, embodiments of the invention can be used or modified with use with systems and methods as disclosed, for example, in U.S. Pub. No. 2018/0368982 to Ball, which is hereby incorporated by reference in its entirety.

[0066] Various other modifications, adaptations, and alternative designs are of course possible in light of the above teachings. Therefore, it should be understood at this time that within the scope of the appended claims the invention may be practiced otherwise than as specifically described herein. It is contemplated that various combinations or subcombinations of the specific features and aspects of the embodiments disclosed above may be made and still fall within one or more of the inventions. Further, the disclosure herein of any particular feature, aspect, method, property, characteristic, quality, attribute, element, or the like in connection with an embodiment can be used in all other embodiments set forth herein. Accordingly, it should be understood that various features and aspects of the disclosed embodiments can be combined with or substituted for one another in order to form varying modes of the disclosed inventions. Thus, it is intended that the scope of the present inventions herein disclosed should not be limited by the particular disclosed embodiments described above. Moreover, while the invention is susceptible to various modifications, and alternative forms, specific examples thereof have been shown in the drawings and are herein described in detail. It should be understood, however, that the invention is not to be limited to the particular forms or methods disclosed, but to the contrary, the invention is to cover all modifications, equivalents, and alternatives falling within the spirit and scope of the various embodiments described and the appended claims. Any methods disclosed herein need not be performed in the order recited. The methods disclosed herein include certain actions taken by a practitioner; however, they can also include any third-party instruction of those actions, either expressly or by implication. For example, actions such as “insetting an implant into a glenoid cavity” includes “instructing the insetting of an implant into the glenoid cavity.” The ranges disclosed herein also encompass any and all overlap, sub-ranges, and combinations thereof. Language such as “up to,” “at least,” “greater than,” “less than,” “between,” and the like includes the number recited. Numbers preceded by a term such as “approximately,” “about,” and “substantially” as used herein include the recited numbers (e.g., about 10%=10%), and also represent an amount close to the stated amount that still performs a desired function or achieves a desired result. For example, the terms “approximately,” “about,” and “substantially” may refer to an amount that is within less than

10% of, within less than 5% of, within less than 1% of, within less than 0.1% of, and within less than 0.01% of the stated amount.

1.-9. (canceled)

10. A reverse shoulder implant, comprising:

a baseplate configured to be secured to a glenoid of a scapular bone of patient, the baseplate having a lateral end, a medial end, and a baseplate central channel extending through the baseplate from the lateral end to the medial end;

a central post configured to at least partially pass through the central channel;

a locking nut having a cylindrical shape, an external thread on an outside surface of the locking nut and an internal thread on an internal surface of the locking nut, the locking nut configured to engage the central post when the central post and baseplate are implanted within the medical patient, wherein the external thread is configured to couple the locking nut with the baseplate central channel;

a glenosphere, having a lateral, convex articular side, a medial side, and a glenosphere central channel extending from the convex articular side to the medial side and configured to interface with the baseplate; and

a glenosphere screw, sized to pass at least partially within the glenosphere central channel and having external threads sized to secure the glenosphere screw to the internal thread on the internal surface of the locking nut to secure the glenosphere to the locking nut.

11. The reverse shoulder implant of claim 10, wherein the glenosphere is configured to at least partially surround an external surface of the baseplate.

12. The reverse shoulder implant of claim 10, wherein the baseplate has a circular shape.

13. The reverse shoulder implant of claim 10, wherein the glenosphere is configured to surround the baseplate.

14. The reverse shoulder implant of claim 10, wherein the glenosphere is configured to be secured to the baseplate with a Morse taper.

15. The reverse shoulder implant of claim 10, wherein a diameter of the locking nut is greater than a length of the locking nut.

16. The reverse shoulder implant of claim 10, wherein the locking nut comprises a rotational control feature configured to receive a tool to enable twisting of the locking nut to secure it to the central screw.

17. The reverse shoulder implant of claim 10, wherein the central post has a length of about 5 mm, 5.5 mm, 6 mm, 6.5 mm, 7 mm, 7.5 mm, 8 mm, 8.5 mm, 9 mm, 9.5 mm, 10 mm, 10.5 mm, 11 mm, 11.5 mm, 12 mm, 12.5 mm, 13 mm, 13.5 mm, 14 mm, 14.5 mm, or 15 mm

18. The reverse shoulder implant of claim 10, wherein the central channel defines a surface integral with the central post.

19. The reverse shoulder implant of claim 10, wherein the central post includes a rotational control feature.

20. The reverse shoulder implant of claim 10, wherein the central post comprises a central channel configured to house a primary screw.

21. A reverse shoulder implant, comprising:

a baseplate configured to be secured to a glenoid of a scapular bone of patient, the baseplate having a lateral

- end, a medial end, and a baseplate central channel extending through the baseplate from the lateral end to the medial end;
- a central post configured to at least partially pass through the central channel;
- a locking nut having a cylindrical shape, an external thread on an outside surface of the locking nut and an internal thread on an internal surface of the locking nut, the locking nut configured to engage the central post when the central post and baseplate are implanted within the medical patient, wherein the external thread is configured to engage the baseplate central channel; and
- a glenosphere, having a lateral, convex articular side, a medial side, and a central channel extending from the convex articular side to the medial side and configured to interface with the baseplate; and a glenosphere screw, sized to pass at least partially within the glenosphere central channel and having external threads sized to secure the glenosphere screw to the internal thread on the internal surface of the locking nut to secure the glenosphere to the locking nut.
- 22.** The reverse shoulder implant of claim **21**, wherein the glenosphere is configured to at least partially surround an external surface of the baseplate.
- 23.** The reverse shoulder implant of claim **21**, wherein the baseplate has a circular shape.
- 24.** The reverse shoulder implant of claim **21**, wherein the glenosphere is configured to surround the baseplate.
- 25.** The reverse shoulder implant of claim **21**, wherein the glenosphere is configured to be secured to the baseplate with a Morse taper.
- 26.** The reverse shoulder implant of claim **21**, wherein a diameter of the locking nut is greater than a length of the locking nut.
- 27.** The reverse shoulder implant of claim **21**, wherein the locking nut comprises a rotational control feature configured to receive a tool to enable twisting of the locking nut to secure it to the central screw.
- 28.** The reverse shoulder implant of claim **21**, wherein the central post has a length of about 5 mm, 5.5 mm, 6 mm, 6.5 mm, 7 mm, 7.5 mm, 8 mm, 8.5 mm, 9 mm, 9.5 mm, 10 mm, 10.5 mm, 11 mm, 11.5 mm, 12 mm, 12.5 mm, 13 mm, 13.5 mm, 14 mm, 14.5 mm, or 15 mm
- 29.** The reverse shoulder implant of claim **21**, wherein the central channel defines a surface integral with the central post.
- 30.** The reverse shoulder implant of claim **21**, wherein the central post includes a rotational control feature.
- 31.** The reverse shoulder implant of claim **21**, wherein the central post comprises a central channel configured to house a primary screw.

* * * * *