



(11) **EP 4 415 358 A2**

(12) **EUROPEAN PATENT APPLICATION**

- (43) Date of publication: **14.08.2024 Bulletin 2024/33**
- (21) Application number: **24185104.7**
- (22) Date of filing: **26.03.2020**
- (51) International Patent Classification (IPC):
H04N 19/13 (2014.01)
- (52) Cooperative Patent Classification (CPC):
**H04N 19/12; H04N 19/13; H04N 19/157;
H04N 19/176; H04N 19/1887; H04N 19/61;
H04N 19/70; H04N 19/96; H04N 19/11**

(84) Designated Contracting States:
**AL AT BE BG CH CY CZ DE DK EE ES FI FR GB
GR HR HU IE IS IT LI LT LU LV MC MK MT NL NO
PL PT RO RS SE SI SK SM TR**

(30) Priority: **26.03.2019 US 201962824243 P**

(62) Document number(s) of the earlier application(s) in accordance with Art. 76 EPC:
20777376.3 / 3 937 501

(71) Applicant: **LG Electronics Inc.**
Yeongdeungpo-gu
Seoul 07336 (KR)

(72) Inventors:
• **KOO, Moonmo**
06772 SEOUL (KR)

- **LIM, Jaehyun**
06772 Seoul (KR)
- **KIM, Seunghwan**
06772 Seoul (KR)
- **NAM, Junghak**
06772 SEOUL (KR)

(74) Representative: **Plasseraud IP**
104 Rue de Richelieu
CS92104
75080 Paris Cedex 02 (FR)

Remarks:

This application was filed on 27.06.2024 as a divisional application to the application mentioned under INID code 62.

(54) **TRANSFORM-BASED IMAGE CODING**

(57) An image decoding method according to the present document comprises a step for performing inverse first-order transform and inverse non-separable transform on a residual sample. The inverse non-separable transform is performed on the basis of a transform index indicating a predetermined transform kernel matrix, the inverse first-order transform is performed on the basis of a multiple transform selection (MTS) index indicating MTS for a horizontal transform kernel and a vertical transform kernel, and a syntax element bin string for the transform index is derived on the basis of first context information when a tree type for a split structure of a target block is not a single tree type and is derived on the basis of second context information when the tree type is the single tree type.

FIG. 9

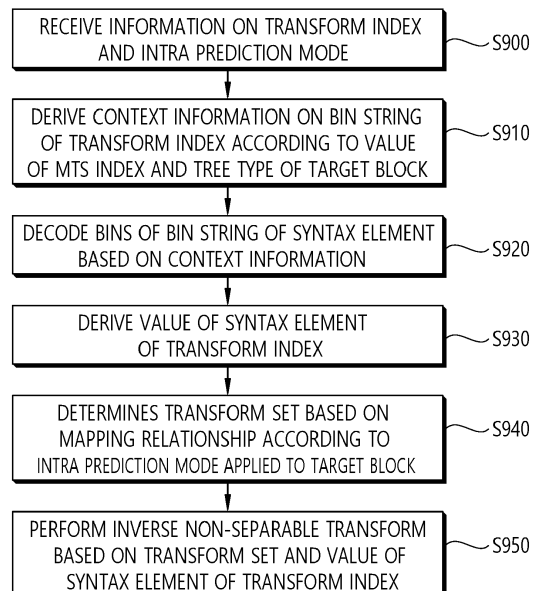

EP 4 415 358 A2

DescriptionTechnical Field

5 **[0001]** The present disclosure relates generally to an image coding technology and, more particularly, to an image coding method based on a transform in an image coding system and an apparatus therefor.

Related Art

10 **[0002]** Nowadays, the demand for high-resolution and high-quality images/videos such as 4K, 8K or more ultra high definition (UHD) images/videos has been increasing in various fields. As the image/video data becomes higher resolution and higher quality, the transmitted information amount or bit amount increases as compared to the conventional image data. Therefore, when image data is transmitted using a medium such as a conventional wired/wireless broadband line or image/video data is stored using an existing storage medium, the transmission cost and the storage cost thereof are increased.

15 **[0003]** Further, nowadays, the interest and demand for immersive media such as virtual reality (VR), artificial reality (AR) content or hologram, or the like is increasing, and broadcasting for images/videos having image features different from those of real images, such as a game image is increasing.

20 **[0004]** Accordingly, there is a need for a highly efficient image/video compression technique for effectively compressing and transmitting or storing, and reproducing information of high resolution and high quality images/videos having various features as described above.

SUMMARY

25 **[0005]** A technical aspect of the present disclosure is to provide a method and an apparatus for increasing image coding efficiency.

[0006] Another technical aspect of the present disclosure is to provide a method and an apparatus for increasing efficiency in transform index coding.

30 **[0007]** Still another technical aspect of the present disclosure is to provide a method and an apparatus for coding a transform index based on a multiple transform technique.

[0008] Yet another technical aspect of the present disclosure is to provide a method and an apparatus for coding the context of a transform index.

35 **[0009]** According to an embodiment of the present disclosure, there is provided an image decoding method performed by a decoding apparatus. The method may include performing an inverse primary transform and an inverse non-separable transform on a residual sample, wherein the inverse non-separable transform may be performed based on a transform index indicating a predetermined transform kernel matrix, the inverse primary transform may be performed based on a multiple transform selection (MTS) index indicating an MTS of a horizontal transform kernel and a vertical transform kernel, and a syntax element bin string of the transform index may be derived based on first context information, when a tree type of a partition structure of the target block is not a single tree type, and may be derived based on second context information, when the tree type is the single tree type.

40 **[0010]** The syntax element bin string of the transform index may be derived based on the first context information when the MTS index has a value of 0 and the tree type is not the single tree type.

[0011] When the MTS index is not received, the MTS index may be inferred to have a value of 0.

45 **[0012]** The syntax element bin string of the transform index may be derived based on the first context information when the MTS index is not received and the tree type is not the single tree type.

[0013] The transform kernel matrix may be included in a transform set determined based on a mapping relationship according to an intra prediction mode applied to the target block, and the transform index may indicate any one of whether the inverse non-separable transform is applied and the transform kernel matrix comprised in the transform set

50 **[0014]** According to another embodiment of the present disclosure, there is provided an image encoding method performed by an encoding apparatus. The method may include: deriving transform coefficients for a target block from residual samples based on a multiple transform selection (MTS) of a horizontal transform kernel and a vertical transform kernel; deriving modified transform coefficients from the transform coefficients based on a predetermined transform kernel matrix for a non-separable transform; and encoding an MTS index indicating the MTS or a transform index indicating the transform kernel matrix, wherein a syntax element bin string of the transform index may be derived based on first context information, when a tree type of a partition structure of the target block is not a single tree type, and may be derived based on second context information, when the tree type is the single tree type.

55 **[0015]** According to still another embodiment of the present disclosure, there may be provided a digital storage medium that stores image data including encoded image information and a bitstream generated according to an image encoding

method performed by an encoding apparatus.

[0016] According to yet another embodiment of the present disclosure, there may be provided a digital storage medium that stores image data including encoded image information and a bitstream to cause a decoding apparatus to perform the image decoding method.

[0017] According to the present disclosure, it is possible to increase overall image/video compression efficiency.

[0018] According to the present disclosure, it is possible to increase efficiency in transform index coding.

[0019] A technical aspect of the present disclosure may provide a method and an apparatus for coding a transform index based on a multiple transform technique.

[0020] Another technical aspect of the present disclosure may provide a method and an apparatus for coding the context of a transform index.

[0021] The effects that can be obtained through specific examples of the present disclosure are not limited to the effects listed above. For example, there may be various technical effects that a person having ordinary skill in the related art can understand or derive from the present disclosure. Accordingly, specific effects of the present disclosure are not limited to those explicitly described in the present disclosure and may include various effects that can be understood or derived from the technical features of the present disclosure.

BRIEF DESCRIPTION OF THE DRAWINGS

[0022]

FIG. 1 schematically illustrates an example of a video/image coding system to which the present disclosure is applicable.

FIG. 2 is a diagram schematically illustrating a configuration of a video/image encoding apparatus to which the present disclosure is applicable.

FIG. 3 is a diagram schematically illustrating a configuration of a video/image decoding apparatus to which the present disclosure is applicable.

FIG. 4 schematically illustrates a multiple transform technique according to an embodiment of the present disclosure.

FIG. 5 illustrates directional intra modes of 65 prediction directions.

FIG. 6 is a diagram illustrating an RST according to an embodiment of the present disclosure.

FIG. 7 illustrates context-adaptive binary arithmetic coding (CABAC) for encoding a syntax element.

FIG. 8 is a flowchart illustrating an operation of a video decoding apparatus according to an embodiment of the present disclosure.

FIG. 9 is a control flowchart illustrating an inverse non-separable transform method based on a transform index according to an embodiment of the present disclosure.

FIG. 10 is a flowchart illustrating an operation of a video encoding apparatus according to an embodiment of the present disclosure.

FIG. 11 is a control flowchart illustrating a non-separable transform method including encoding of a transform index according to an embodiment of the present disclosure.

FIG. 12 illustrates the structure of a content streaming system to which the present disclosure is applied.

DESCRIPTION OF EXEMPLARY EMBODIMENTS

[0023] While the present disclosure may be susceptible to various modifications and include various embodiments, specific embodiments thereof have been shown in the drawings by way of example and will now be described in detail. However, this is not intended to limit the present disclosure to the specific embodiments disclosed herein. The terminology used herein is for the purpose of describing specific embodiments only, and is not intended to limit technical idea of the present disclosure. The singular forms may include the plural forms unless the context clearly indicates otherwise. The terms such as "include" and "have" are intended to indicate that features, numbers, steps, operations, elements, components, or combinations thereof used in the following description exist, and thus should not be understood as that the possibility of existence or addition of one or more different features, numbers, steps, operations, elements, components, or combinations thereof is excluded in advance.

[0024] Meanwhile, each component on the drawings described herein is illustrated independently for convenience of description as to characteristic functions different from each other, and however, it is not meant that each component is realized by a separate hardware or software. For example, any two or more of these components may be combined to form a single component, and any single component may be divided into plural components. The embodiments in which components are combined and/or divided will belong to the scope of the patent right of the present disclosure as long as they do not depart from the essence of the present disclosure.

[0025] Hereinafter, preferred embodiments of the present disclosure will be explained in more detail while referring to

the attached drawings. In addition, the same reference signs are used for the same components on the drawings, and repeated descriptions for the same components will be omitted.

[0026] This document relates to video/image coding. For example, the method/example disclosed in this document may relate to a VVC (Versatile Video Coding) standard (ITU-T Rec. H.266), a next-generation video/image coding standard after VVC, or other video coding related standards (e.g., HEVC (High Efficiency Video Coding) standard (ITU-T Rec. H.265), EVC (essential video coding) standard, AVS2 standard, etc.).

[0027] In this document, a variety of embodiments relating to video/image coding may be provided, and, unless specified to the contrary, the embodiments may be combined to each other and be performed.

[0028] In this document, a video may mean a set of a series of images over time. Generally a picture means a unit representing an image at a specific time zone, and a slice/tile is a unit constituting a part of the picture. The slice/tile may include one or more coding tree units (CTUs). One picture may be constituted by one or more slices/tiles. One picture may be constituted by one or more tile groups. One tile group may include one or more tiles.

[0029] A pixel or a pel may mean a smallest unit constituting one picture (or image). Also, 'sample' may be used as a term corresponding to a pixel. A sample may generally represent a pixel or a value of a pixel, and may represent only a pixel/pixel value of a luma component or only a pixel/pixel value of a chroma component. Alternatively, the sample may refer to a pixel value in the spatial domain, or when this pixel value is converted to the frequency domain, it may refer to a transform coefficient in the frequency domain.

[0030] A unit may represent the basic unit of image processing. The unit may include at least one of a specific region and information related to the region. One unit may include one luma block and two chroma (e.g., cb, cr) blocks. The unit and a term such as a block, an area, or the like may be used in place of each other according to circumstances. In a general case, an $M \times N$ block may include a set (or an array) of samples (or sample arrays) or transform coefficients consisting of M columns and N rows.

[0031] In this document, the term "/" and "," should be interpreted to indicate "and/or." For instance, the expression "A/B" may mean "A and/or B." Further, "A, B" may mean "A and/or B." Further, "A/B/C" may mean "at least one of A, B, and/or C." Also, "A/B/C" may mean "at least one of A, B, and/or C."

[0032] Further, in the document, the term "or" should be interpreted to indicate "and/or." For instance, the expression "A or B" may include 1) only A, 2) only B, and/or 3) both A and B. In other words, the term "or" in this document should be interpreted to indicate "additionally or alternatively."

[0033] In the present disclosure, "at least one of A and B" may mean "only A", "only B", or "both A and B". In addition, in the present disclosure, the expression "at least one of A or B" or "at least one of A and/or B" may be interpreted as "at least one of A and B".

[0034] In addition, in the present disclosure, "at least one of A, B, and C" may mean "only A", "only B", "only C", or "any combination of A, B, and C". In addition, "at least one of A, B, or C" or "at least one of A, B, and/or C" may mean "at least one of A, B, and C".

[0035] In addition, a parenthesis used in the present disclosure may mean "for example". Specifically, when indicated as "prediction (intra prediction)", it may mean that "intra prediction" is proposed as an example of "prediction". In other words, the "prediction" of the present disclosure is not limited to "intra prediction", and "intra prediction" may be proposed as an example of "prediction". In addition, when indicated as "prediction (i.e., intra prediction)", it may also mean that "intra prediction" is proposed as an example of "prediction".

[0036] Technical features individually described in one figure in the present disclosure may be individually implemented or may be simultaneously implemented.

[0037] FIG. 1 schematically illustrates an example of a video/image coding system to which the present disclosure is applicable.

[0038] Referring to FIG. 1, the video/image coding system may include a first device (source device) and a second device (receive device). The source device may deliver encoded video/image information or data in the form of a file or streaming to the receive device via a digital storage medium or network.

[0039] The source device may include a video source, an encoding apparatus, and a transmitter. The receive device may include a receiver, a decoding apparatus, and a renderer. The encoding apparatus may be called a video/image encoding apparatus, and the decoding apparatus may be called a video/image decoding apparatus. The transmitter may be included in the encoding apparatus. The receiver may be included in the decoding apparatus. The renderer may include a display, and the display may be configured as a separate device or an external component.

[0040] The video source may obtain a video/image through a process of capturing, synthesizing, or generating a video/image. The video source may include a video/image capture device and/or a video/image generating device. The video/image capture device may include, for example, one or more cameras, video/image archives including previously captured video/images, or the like. The video/image generating device may include, for example, a computer, a tablet and a smartphone, and may (electronically) generate a video/image. For example, a virtual video/image may be generated through a computer or the like. In this case, the video/image capturing process may be replaced by a process of generating related data.

[0041] The encoding apparatus may encode an input video/image. The encoding apparatus may perform a series of procedures such as prediction, transform, and quantization for compression and coding efficiency. The encoded data (encoded video/image information) may be output in the form of a bitstream.

[0042] The transmitter may transmit the encoded video/image information or data output in the form of a bitstream to the receiver of the receive device through a digital storage medium or a network in the form of a file or streaming. The digital storage medium may include various storage mediums such as USB, SD, CD, DVD, Blu-ray, HDD, SSD, and the like. The transmitter may include an element for generating a media file through a predetermined file format, and may include an element for transmission through a broadcast/communication network. The receiver may receive/extract the bitstream and transmit the received/extracted bitstream to the decoding apparatus.

[0043] The decoding apparatus may decode a video/image by performing a series of procedures such as dequantization, inverse transform, prediction, and the like corresponding to the operation of the encoding apparatus.

[0044] The renderer may render the decoded video/image. The rendered video/image may be displayed through the display.

[0045] FIG. 2 is a diagram schematically illustrating a configuration of a video/image encoding apparatus to which the present disclosure is applicable. Hereinafter, what is referred to as the video encoding apparatus may include an image encoding apparatus.

[0046] Referring to FIG. 2, the encoding apparatus 200 may include an image partitioner 210, a predictor 220, a residual processor 230, an entropy encoder 240, an adder 250, a filter 260, and a memory 270. The predictor 220 may include an inter predictor 221 and an intra predictor 222. The residual processor 230 may include a transformer 232, a quantizer 233, a dequantizer 234, an inverse transformer 235. The residual processor 230 may further include a subtractor 231. The adder 250 may be called a reconstructor or reconstructed block generator. The image partitioner 210, the predictor 220, the residual processor 230, the entropy encoder 240, the adder 250, and the filter 260, which have been described above, may be constituted by one or more hardware components (e.g., encoder chipsets or processors) according to an embodiment. Further, the memory 270 may include a decoded picture buffer (DPB), and may be constituted by a digital storage medium. The hardware component may further include the memory 270 as an internal/external component.

[0047] The image partitioner 210 may partition an input image (or a picture or a frame) input to the encoding apparatus 200 into one or more processing units. As one example, the processing unit may be called a coding unit (CU). In this case, starting with a coding tree unit (CTU) or the largest coding unit (LCU), the coding unit may be recursively partitioned according to the Quad-tree binary-tree ternary-tree (QTBT) structure. For example, one coding unit may be divided into a plurality of coding units of a deeper depth based on the quad-tree structure, the binary-tree structure, and/or the ternary structure. In this case, for example, the quad-tree structure may be applied first and the binary-tree structure and/or the ternary structure may be applied later. Alternatively, the binary-tree structure may be applied first. The coding procedure according to the present disclosure may be performed based on the final coding unit which is not further partitioned. In this case, the maximum coding unit may be used directly as a final coding unit based on coding efficiency according to the image characteristic. Alternatively, the coding unit may be recursively partitioned into coding units of a further deeper depth as needed, so that the coding unit of an optimal size may be used as a final coding unit. Here, the coding procedure may include procedures such as prediction, transform, and reconstruction, which will be described later. As another example, the processing unit may further include a prediction unit (PU) or a transform unit (TU). In this case, the prediction unit and the transform unit may be split or partitioned from the above-described final coding unit. The prediction unit may be a unit of sample prediction, and the transform unit may be a unit for deriving a transform coefficient and/or a unit for deriving a residual signal from a transform coefficient.

[0048] The unit and a term such as a block, an area, or the like may be used in place of each other according to circumstances. In a general case, an $M \times N$ block may represent a set of samples or transform coefficients consisting of M columns and N rows. The sample may generally represent a pixel or a value of a pixel, and may represent only a pixel/pixel value of a luma component, or only a pixel/pixel value of a chroma component. The sample may be used as a term corresponding to a pixel or a pel of one picture (or image).

[0049] The subtractor 231 subtracts a prediction signal (predicted block, prediction sample array) output from the inter predictor 221 or the intra predictor 222 from an input image signal (original block, original sample array) to generate a residual signal (residual block, residual sample array), and the generated residual signal is transmitted to the transformer 232. In this case, as shown, a unit which subtracts the prediction signal (predicted block, prediction sample array) from the input image signal (original block, original sample array) in the encoder 200 may be called the subtractor 231. The predictor may perform prediction on a processing target block (hereinafter, referred to as 'current block'), and may generate a predicted block including prediction samples for the current block. The predictor may determine whether intra prediction or inter prediction is applied on a current block or CU basis. As discussed later in the description of each prediction mode, the predictor may generate various information relating to prediction, such as prediction mode information, and transmit the generated information to the entropy encoder 240. The information on the prediction may be encoded in the entropy encoder 240 and output in the form of a bitstream.

[0050] The intra predictor 222 may predict the current block by referring to samples in the current picture. The referred samples may be located in the neighbor of or apart from the current block according to the prediction mode. In the intra prediction, prediction modes may include a plurality of non-directional modes and a plurality of directional modes. The non-directional modes may include, for example, a DC mode and a planar mode. The directional mode may include, for example, 33 directional prediction modes or 65 directional prediction modes according to the degree of detail of the prediction direction. However, this is merely an example, and more or less directional prediction modes may be used depending on a setting. The intra predictor 222 may determine the prediction mode applied to the current block by using the prediction mode applied to the neighboring block.

[0051] The inter predictor 221 may derive a predicted block for the current block based on a reference block (reference sample array) specified by a motion vector on a reference picture. At this time, in order to reduce the amount of motion information transmitted in the inter prediction mode, the motion information may be predicted on a block, subblock, or sample basis based on correlation of motion information between the neighboring block and the current block. The motion information may include a motion vector and a reference picture index. The motion information may further include inter prediction direction (L0 prediction, L1 prediction, Bi prediction, etc.) information. In the case of inter prediction, the neighboring block may include a spatial neighboring block existing in the current picture and a temporal neighboring block existing in the reference picture. The reference picture including the reference block and the reference picture including the temporal neighboring block may be same to each other or different from each other. The temporal neighboring block may be called a collocated reference block, a collocated CU (colCU), and the like, and the reference picture including the temporal neighboring block may be called a collocated picture (colPic). For example, the inter predictor 221 may configure a motion information candidate list based on neighboring blocks and generate information indicating which candidate is used to derive a motion vector and/or a reference picture index of the current block. Inter prediction may be performed based on various prediction modes. For example, in the case of a skip mode and a merge mode, the inter predictor 221 may use motion information of the neighboring block as motion information of the current block. In the skip mode, unlike the merge mode, the residual signal may not be transmitted. In the case of the motion information prediction (motion vector prediction, MVP) mode, the motion vector of the neighboring block may be used as a motion vector predictor and the motion vector of the current block may be indicated by signaling a motion vector difference.

[0052] The predictor 220 may generate a prediction signal based on various prediction methods. For example, the predictor may apply intra prediction or inter prediction for prediction on one block, and, as well, may apply intra prediction and inter prediction at the same time. This may be called combined inter and intra prediction (CIIP). Further, the predictor may be based on an intra block copy (IBC) prediction mode, or a palette mode in order to perform prediction on a block. The IBC prediction mode or palette mode may be used for content image/video coding of a game or the like, such as screen content coding (SCC). Although the IBC basically performs prediction in a current block, it can be performed similarly to inter prediction in that it derives a reference block in a current block. That is, the IBC may use at least one of inter prediction techniques described in the present disclosure.

[0053] The prediction signal generated through the inter predictor 221 and/or the intra predictor 222 may be used to generate a reconstructed signal or to generate a residual signal. The transformer 232 may generate transform coefficients by applying a transform technique to the residual signal. For example, the transform technique may include at least one of a discrete cosine transform (DCT), a discrete sine transform (DST), a Karhunen-Loève transform (KLT), a graph-based transform (GBT), or a conditionally non-linear transform (CNT). Here, the GBT means transform obtained from a graph when relationship information between pixels is represented by the graph. The CNT refers to transform obtained based on a prediction signal generated using all previously reconstructed pixels. In addition, the transform process may be applied to square pixel blocks having the same size or may be applied to blocks having a variable size rather than the square one.

[0054] The quantizer 233 may quantize the transform coefficients and transmit them to the entropy encoder 240, and the entropy encoder 240 may encode the quantized signal (information on the quantized transform coefficients) and output the encoded signal in a bitstream. The information on the quantized transform coefficients may be referred to as residual information. The quantizer 233 may rearrange block type quantized transform coefficients into a one-dimensional vector form based on a coefficient scan order, and generate information on the quantized transform coefficients based on the quantized transform coefficients of the one-dimensional vector form. The entropy encoder 240 may perform various encoding methods such as, for example, exponential Golomb, context-adaptive variable length coding (CAVLC), context-adaptive binary arithmetic coding (CABAC), and the like. The entropy encoder 240 may encode information necessary for video/image reconstruction other than quantized transform coefficients (e.g. values of syntax elements, etc.) together or separately. Encoded information (e.g., encoded video/image information) may be transmitted or stored on a unit basis of a network abstraction layer (NAL) in the form of a bitstream. The video/image information may further include information on various parameter sets such as an adaptation parameter set (APS), a picture parameter set (PPS), a sequence parameter set (SPS), a video parameter set (VPS) or the like. Further, the video/image information may further include general constraint information. In the present disclosure, information and/or syntax elements which are transmitted/signaled to the decoding apparatus from the encoding apparatus may be included in video/image infor-

mation. The video/image information may be encoded through the above-described encoding procedure and included in the bitstream. The bitstream may be transmitted through a network, or stored in a digital storage medium. Here, the network may include a broadcast network, a communication network and/or the like, and the digital storage medium may include various storage media such as USB, SD, CD, DVD, Blu-ray, HDD, SSD, and the like. A transmitter (not shown) which transmits a signal output from the entropy encoder 240 and/or a storage (not shown) which stores it may be configured as an internal/external element of the encoding apparatus 200, or the transmitter may be included in the entropy encoder 240.

[0055] Quantized transform coefficients output from the quantizer 233 may be used to generate a prediction signal. For example, by applying dequantization and inverse transform to quantized transform coefficients through the dequantizer 234 and the inverse transformer 235, the residual signal (residual block or residual samples) may be reconstructed. The adder 155 adds the reconstructed residual signal to a prediction signal output from the inter predictor 221 or the intra predictor 222, so that a reconstructed signal (reconstructed picture, reconstructed block, reconstructed sample array) may be generated. When there is no residual for a processing target block as in a case where the skip mode is applied, the predicted block may be used as a reconstructed block. The adder 250 may be called a reconstructor or a reconstructed block generator. The generated reconstructed signal may be used for intra prediction of a next processing target block in the current block, and as described later, may be used for inter prediction of a next picture through filtering.

[0056] Meanwhile, in the picture encoding and/or reconstructing process, luma mapping with chroma scaling (LMCS) may be applied.

[0057] The filter 260 may improve subjective/objective video quality by applying the filtering to the reconstructed signal. For example, the filter 260 may generate a modified reconstructed picture by applying various filtering methods to the reconstructed picture, and may store the modified reconstructed picture in the memory 270, specifically in the DPB of the memory 270. The various filtering methods may include, for example, deblocking filtering, sample adaptive offset, an adaptive loop filter, a bilateral filter or the like. As discussed later in the description of each filtering method, the filter 260 may generate various information relating to filtering, and transmit the generated information to the entropy encoder 240. The information on the filtering may be encoded in the entropy encoder 240 and output in the form of a bitstream.

[0058] The modified reconstructed picture which has been transmitted to the memory 270 may be used as a reference picture in the inter predictor 221. Through this, the encoding apparatus can avoid prediction mismatch in the encoding apparatus 100 and a decoding apparatus when the inter prediction is applied, and can also improve coding efficiency.

[0059] The memory 270 DPB may store the modified reconstructed picture in order to use it as a reference picture in the inter predictor 221. The memory 270 may store motion information of a block in the current picture, from which motion information has been derived (or encoded) and/or motion information of blocks in an already reconstructed picture. The stored motion information may be transmitted to the inter predictor 221 to be utilized as motion information of a neighboring block or motion information of a temporal neighboring block. The memory 270 may store reconstructed samples of reconstructed blocks in the current picture, and transmit them to the intra predictor 222.

[0060] FIG. 3 is a diagram schematically illustrating a configuration of a video/image decoding apparatus to which the present disclosure is applicable.

[0061] Referring to FIG. 3, the video decoding apparatus 300 may include an entropy decoder 310, a residual processor 320, a predictor 330, an adder 340, a filter 350 and a memory 360. The predictor 330 may include an inter predictor 331 and an intra predictor 332. The residual processor 320 may include a dequantizer 321 and an inverse transformer 321. The entropy decoder 310, the residual processor 320, the predictor 330, the adder 340, and the filter 350, which have been described above, may be constituted by one or more hardware components (e.g., decoder chipsets or processors) according to an embodiment. Further, the memory 360 may include a decoded picture buffer (DPB), and may be constituted by a digital storage medium. The hardware component may further include the memory 360 as an internal/external component.

[0062] When a bitstream including video/image information is input, the decoding apparatus 300 may reconstruct an image correspondingly to a process by which video/image information has been processed in the encoding apparatus of FIG. 2. For example, the decoding apparatus 300 may derive units/blocks based on information relating to block partition obtained from the bitstream. The decoding apparatus 300 may perform decoding by using a processing unit applied in the encoding apparatus. Therefore, the processing unit of decoding may be, for example, a coding unit, which may be partitioned along the quad-tree structure, the binary-tree structure, and/or the ternary-tree structure from a coding tree unit or a largest coding unit. One or more transform units may be derived from the coding unit. And, the reconstructed image signal decoded and output through the decoding apparatus 300 may be reproduced through a reproducer.

[0063] The decoding apparatus 300 may receive a signal output from the encoding apparatus of FIG. 2 in the form of a bitstream, and the received signal may be decoded through the entropy decoder 310. For example, the entropy decoder 310 may parse the bitstream to derive information (e.g., video/image information) required for image reconstruction (or picture reconstruction). The video/image information may further include information on various parameter sets such as an adaptation parameter set (APS), a picture parameter set (PPS), a sequence parameter set (SPS), a video parameter

set (VPS) or the like. Further, the video/image information may further include general constraint information. The decoding apparatus may decode a picture further based on information on the parameter set and/or the general constraint information. In the present disclosure, signaled/received information and/or syntax elements, which will be described later, may be decoded through the decoding procedure and be obtained from the bitstream. For example, the entropy decoder 310 may decode information in the bitstream based on a coding method such as exponential Golomb encoding, CAVLC, CABAC, or the like, and may output a value of a syntax element necessary for image reconstruction and quantized values of a transform coefficient regarding a residual. More specifically, a CABAC entropy decoding method may receive a bin corresponding to each syntax element in a bitstream, determine a context model using decoding target syntax element information and decoding information of neighboring and decoding target blocks, or information of symbol/bin decoded in a previous step, predict bin generation probability according to the determined context model and perform arithmetic decoding of the bin to generate a symbol corresponding to each syntax element value. Here, the CABAC entropy decoding method may update the context model using information of a symbol/bin decoded for a context model of the next symbol/bin after determination of the context model. Information on prediction among information decoded in the entropy decoder 310 may be provided to the predictor (inter predictor 332 and intra predictor 331), and residual values, that is, quantized transform coefficients, on which entropy decoding has been performed in the entropy decoder 310, and associated parameter information may be input to the residual processor 320. The residual processor 320 may derive a residual signal (residual block, residual samples, residual sample array). Further, information on filtering among information decoded in the entropy decoder 310 may be provided to the filter 350. Meanwhile, a receiver (not shown) which receives a signal output from the encoding apparatus may further constitute the decoding apparatus 300 as an internal/external element, and the receiver may be a component of the entropy decoder 310. Meanwhile, the decoding apparatus according to the present disclosure may be called a video/image/picture coding apparatus, and the decoding apparatus may be classified into an information decoder (video/image/picture information decoder) and a sample decoder (video/image/picture sample decoder). The information decoder may include the entropy decoder 310, and the sample decoder may include at least one of the dequantizer 321, the inverse transformer 322, the adder 340, the filter 350, the memory 360, the inter predictor 332, and the intra predictor 331.

[0064] The dequantizer 321 may output transform coefficients by dequantizing the quantized transform coefficients. The dequantizer 321 may rearrange the quantized transform coefficients in the form of a two-dimensional block. In this case, the rearrangement may perform rearrangement based on an order of coefficient scanning which has been performed in the encoding apparatus. The dequantizer 321 may perform dequantization on the quantized transform coefficients using quantization parameter (e.g., quantization step size information), and obtain transform coefficients.

[0065] The dequantizer 322 obtains a residual signal (residual block, residual sample array) by inverse transforming transform coefficients.

[0066] The predictor may perform prediction on the current block, and generate a predicted block including prediction samples for the current block. The predictor may determine whether intra prediction or inter prediction is applied to the current block based on the information on prediction output from the entropy decoder 310, and specifically may determine an intra/inter prediction mode.

[0067] The predictor may generate a prediction signal based on various prediction methods. For example, the predictor may apply intra prediction or inter prediction for prediction on one block, and, as well, may apply intra prediction and inter prediction at the same time. This may be called combined inter and intra prediction (CIIP). In addition, the predictor may perform intra block copy (IBC) for prediction on a block. The intra block copy may be used for content image/video coding of a game or the like, such as screen content coding (SCC). Although the IBC basically performs prediction in a current block, it can be performed similarly to inter prediction in that it derives a reference block in a current block. That is, the IBC may use at least one of inter prediction techniques described in the present disclosure.

[0068] The intra predictor 331 may predict the current block by referring to the samples in the current picture. The referred samples may be located in the neighbor of or apart from the current block according to the prediction mode. In the intra prediction, prediction modes may include a plurality of non-directional modes and a plurality of directional modes. The intra predictor 331 may determine the prediction mode applied to the current block by using the prediction mode applied to the neighboring block.

[0069] The inter predictor 332 may derive a predicted block for the current block based on a reference block (reference sample array) specified by a motion vector on a reference picture. At this time, in order to reduce the amount of motion information transmitted in the inter prediction mode, the motion information may be predicted on a block, subblock, or sample basis based on correlation of motion information between the neighboring block and the current block. The motion information may include a motion vector and a reference picture index. The motion information may further include inter prediction direction (L0 prediction, L1 prediction, Bi prediction, etc.) information. In the case of inter prediction, the neighboring block may include a spatial neighboring block existing in the current picture and a temporal neighboring block existing in the reference picture. For example, the inter predictor 332 may configure a motion information candidate list based on neighboring blocks, and derive a motion vector and/or a reference picture index of the current block based on received candidate selection information. Inter prediction may be performed based on various prediction modes, and

the information on prediction may include information indicating a mode of inter prediction for the current block.

[0070] The adder 340 may generate a reconstructed signal (reconstructed picture, reconstructed block, reconstructed sample array) by adding the obtained residual signal to the prediction signal (predicted block, prediction sample array) output from the predictor 330. When there is no residual for a processing target block as in a case where the skip mode is applied, the predicted block may be used as a reconstructed block.

[0071] The adder 340 may be called a reconstructor or a reconstructed block generator. The generated reconstructed signal may be used for intra prediction of a next processing target block in the current block, and as described later, may be output through filtering or be used for inter prediction of a next picture.

[0072] Meanwhile, in the picture decoding process, luma mapping with chroma scaling (LMCS) may be applied.

[0073] The filter 350 may improve subjective/objective video quality by applying the filtering to the reconstructed signal. For example, the filter 350 may generate a modified reconstructed picture by applying various filtering methods to the reconstructed picture, and may transmit the modified reconstructed picture in the memory 360, specifically in the DPB of the memory 360. The various filtering methods may include, for example, deblocking filtering, sample adaptive offset, an adaptive loop filter, a bilateral filter or the like.

[0074] The (modified) reconstructed picture which has been stored in the DPB of the memory 360 may be used as a reference picture in the inter predictor 332. The memory 360 may store motion information of a block in the current picture, from which motion information has been derived (or decoded) and/or motion information of blocks in an already reconstructed picture. The stored motion information may be transmitted to the inter predictor 260 to be utilized as motion information of a neighboring block or motion information of a temporal neighboring block. The memory 360 may store reconstructed samples of reconstructed blocks in the current picture, and transmit them to the intra predictor 331.

[0075] In this specification, the examples described in the predictor 330, the dequantizer 321, the inverse transformer 322, and the filter 350 of the decoding apparatus 300 may be similarly or correspondingly applied to the predictor 220, the dequantizer 234, the inverse transformer 235, and the filter 260 of the encoding apparatus 200, respectively.

[0076] As described above, prediction is performed in order to increase compression efficiency in performing video coding. Through this, a predicted block including prediction samples for a current block, which is a coding target block, may be generated. Here, the predicted block includes prediction samples in a space domain (or pixel domain). The predicted block may be indentially derived in the encoding apparatus and the decoding apparatus, and the encoding apparatus may increase image coding efficiency by signaling to the decoding apparatus not original sample value of an original block itself but information on residual (residual information) between the original block and the predicted block. The decoding apparatus may derive a residual block including residual samples based on the residual information, generate a reconstructed block including reconstructed samples by adding the residual block to the predicted block, and generate a reconstructed picture including reconstructed blocks.

[0077] The residual information may be generated through transform and quantization procedures. For example, the encoding apparatus may derive a residual block between the original block and the predicted block, derive transform coefficients by performing a transform procedure on residual samples (residual sample array) included in the residual block, and derive quantized transform coefficients by performing a quantization procedure on the transform coefficients, so that it may signal associated residual information to the decoding apparatus (through a bitstream). Here, the residual information may include value information, position information, a transform technique, transform kernel, a quantization parameter or the like of the quantized transform coefficients. The decoding apparatus may perform a quantization/de-quantization procedure and derive the residual samples (or residual sample block), based on residual information. The decoding apparatus may generate a reconstructed block based on a predicted block and the residual block. The encoding apparatus may derive a residual block by dequantizing/inverse transforming quantized transform coefficients for reference for inter prediction of a next picture, and may generate a reconstructed picture based on this.

[0078] FIG. 4 schematically illustrates a multiple transform technique according to an embodiment of the present disclosure.

[0079] Referring to FIG. 4, a transformer may correspond to the transformer in the encoding apparatus of foregoing FIG. 2, and an inverse transformer may correspond to the inverse transformer in the encoding apparatus of foregoing FIG. 2, or to the inverse transformer in the decoding apparatus of FIG. 3.

[0080] The transformer may derive (primary) transform coefficients by performing a primary transform based on residual samples (residual sample array) in a residual block (S410). This primary transform may be referred to as a core transform. Herein, the primary transform may be based on multiple transform selection (MTS), and when a multiple transform is applied as the primary transform, it may be referred to as a multiple core transform.

[0081] The multiple core transform may represent a method of transforming additionally using discrete cosine transform (DCT) type 2 and discrete sine transform (DST) type 7, DCT type 8, and/or DST type 1. That is, the multiple core transform may represent a transform method of transforming a residual signal (or residual block) of a space domain into transform coefficients (or primary transform coefficients) of a frequency domain based on a plurality of transform kernels selected from among the DCT type 2, the DST type 7, the DCT type 8 and the DST type 1. Herein, the primary transform coefficients may be called temporary transform coefficients from the viewpoint of the transformer.

[0082] In other words, when the conventional transform method is applied, transform coefficients might be generated by applying transform from a space domain to a frequency domain for a residual signal (or residual block) based on the DCT type 2. Unlike to this, when the multiple core transform is applied, transform coefficients (or primary transform coefficients) may be generated by applying transform from a space domain to a frequency domain for a residual signal (or residual block) based on the DCT type 2, the DST type 7, the DCT type 8, and/or DST type 1. Herein, the DCT type 2, the DST type 7, the DCT type 8, and the DST type 1 may be called a transform type, transform kernel or transform core. These DCT/DST transform types can be defined based on basis functions.

[0083] If the multiple core transform is performed, then a vertical transform kernel and a horizontal transform kernel for a target block may be selected from among the transform kernels, a vertical transform for the target block may be performed based on the vertical transform kernel, and a horizontal transform for the target block may be performed based on the horizontal transform kernel. Here, the horizontal transform may represent a transform for horizontal components of the target block, and the vertical transform may represent a transform for vertical components of the target block. The vertical transform kernel/horizontal transform kernel may be adaptively determined based on a prediction mode and/or a transform index of a target block (CU or sub-block) including a residual block.

[0084] Further, according to an example, if the primary transform is performed by applying the MTS, a mapping relationship for transform kernels may be set by setting specific basis functions to predetermined values and combining basis functions to be applied in the vertical transform or the horizontal transform. For example, when the horizontal transform kernel is expressed as trTypeHor and the vertical direction transform kernel is expressed as trTypeVer, a trTypeHor or trTypeVer value of 0 may be set to DCT2, a trTypeHor or trTypeVer value of 1 may be set to DST7, and a trTypeHor or trTypeVer value of 2 may be set to DCT8.

[0085] In this case, MTS index information may be encoded and signaled to the decoding apparatus to indicate any one of a plurality of transform kernel sets. For example, an MTS index of 0 may indicate that both trTypeHor and trTypeVer values are 0, an MTS index of 1 may indicate that both trTypeHor and trTypeVer values are 1, an MTS index of 2 may indicate that the trTypeHor value is 2 and the trTypeVer value is 1, an MTS index of 3 may indicate that the trTypeHor value is 1 and the trTypeVer value is 2, and an MTS index of 4 may indicate that both both trTypeHor and trTypeVer values are 2.

[0086] In one example, transform kernel sets according to MTS index information are illustrated in the following table.

[Table 1]

tu_mts_idx[x0][y0]	0	1	2	3	4
trTypeHor	0	1	2	1	2
trTypeVer	0	1	1	2	2

[0087] The transformer may derive modified (secondary) transform coefficients by performing the secondary transform based on the (primary) transform coefficients (S420). The primary transform is a transform from a spatial domain to a frequency domain, and the secondary transform refers to transforming into a more compressive expression by using a correlation existing between (primary) transform coefficients. The secondary transform may include a non-separable transform. In this case, the secondary transform may be called a non-separable secondary transform (NSST), or a mode-dependent non-separable secondary transform (MDNSST). The non-separable secondary transform may represent a transform which generates modified transform coefficients (or secondary transform coefficients) for a residual signal by secondary-transforming, based on a non-separable transform matrix, (primary) transform coefficients derived through the primary transform. At this time, the vertical transform and the horizontal transform may not be applied separately (or horizontal and vertical transforms may not be applied independently) to the (primary) transform coefficients, but the transforms may be applied at once based on the non-separable transform matrix. In other words, the non-separable secondary transform may represent a transform method in which the vertical and horizontal components of the (primary) transform coefficients are not separated, and for example, two-dimensional signals (transform coefficients) are rearranged to a one-dimensional signal through a certain determined direction (e.g., row-first direction or column-first direction), and then modified transform coefficients (or secondary transform coefficients) are generated based on the non-separable transform matrix. For example, according to a row-first order, M × N blocks are disposed in a line in an order of a first row, a second row, ..., and an Nth row. According to a column-first order, M × N blocks are disposed in a line in an order of a first column, a second column, ..., and an Nth column. The non-separable secondary transform may be applied to a top-left region of a block configured with (primary) transform coefficients (hereinafter, may be referred to as a transform coefficient block). For example, if the width (W) and the height (H) of the transform coefficient block are all equal to or greater than 8, an 8x8 non-separable secondary transform may be applied to a top-left 8x8 region of the transform coefficient block. Further, if the width (W) and the height (H) of the transform coefficient block are all equal to or greater than 4, and the width (W) or the height (H) of the transform coefficient block is less than 8, then a 4x4 non-

separable secondary transform may be applied to a top-left $\min(8,W) \times \min(8,H)$ region of the transform coefficient block. However, the embodiment is not limited to this, and for example, even if only the condition that the width (W) or height (H) of the transform coefficient block is equal to or greater than 4 is satisfied, the 4×4 non-separable secondary transform may be applied to the top-left $\min(8,W) \times \min(8,H)$ region of the transform coefficient block.

5 **[0088]** Specifically, for example, if a 4×4 input block is used, the non-separable secondary transform may be performed as follows.

[0089] The 4×4 input block X may be represented as follows.

10 [Equation 1]

$$15 \quad X = \begin{bmatrix} X_{00} & X_{01} & X_{02} & X_{03} \\ X_{10} & X_{11} & X_{12} & X_{13} \\ X_{20} & X_{21} & X_{22} & X_{23} \\ X_{30} & X_{31} & X_{32} & X_{33} \end{bmatrix}$$

20 **[0090]** If the X is represented in the form of a vector, the vector \vec{X} may be represented as below.

25 [Equation 2]

$$\vec{X} = [X_{00} \ X_{01} \ X_{02} \ X_{03} \ X_{10} \ X_{11} \ X_{12} \ X_{13} \ X_{20} \ X_{21} \ X_{22} \ X_{23} \ X_{30} \ X_{31} \ X_{32} \ X_{33}]^T$$

30 **[0091]** In Equation 2, the vector \vec{X} is a one-dimensional vector obtained by rearranging the two-dimensional block X of Equation 1 according to the row-first order.

[0092] In this case, the secondary non-separable transform may be calculated as below.

35 [Equation 3]

$$40 \quad \vec{F} = T \cdot \vec{X}$$

45 **[0093]** In this equation, \vec{F} represents a transform coefficient vector, and T represents a 16×16 (non-separable) transform matrix.

[0094] Through foregoing Equation 3, a 16×1 transform coefficient vector \vec{F} may be derived, and the \vec{F} may be re-organized into a 4×4 block through a scan order (horizontal, vertical, diagonal and the like). However, the above-described calculation is an example, and hypercube-Givens transform (HyGT) or the like may be used for the calculation of the non-separable secondary transform in order to reduce the computational complexity of the non-separable secondary transform.

[0095] Meanwhile, in the non-separable secondary transform, a transform kernel (or transform core, transform type) may be selected to be mode dependent. In this case, the mode may include the intra prediction mode and/or the inter prediction mode.

55 **[0096]** As described above, the non-separable secondary transform may be performed based on an 8×8 transform or a 4×4 transform determined based on the width (W) and the height (H) of the transform coefficient block. The 8×8 transform refers to a transform that is applicable to an 8×8 region included in the transform coefficient block when both W and H are equal to or greater than 8, and the 8×8 region may be a top-left 8×8 region in the transform coefficient

block. Similarly, the 4x4 transform refers to a transform that is applicable to a 4x4 region included in the transform coefficient block when both W and H are equal to or greater than 4, and the 4x4 region may be a top-left 4x4 region in the transform coefficient block. For example, an 8x8 transform kernel matrix may be a 64x64/16x64 matrix, and a 4x4 transform kernel matrix may be a 16x16/8x16 matrix.

5 **[0097]** Here, to select a mode-dependent transform kernel, two non-separable secondary transform kernels per transform set for a non-separable secondary transform may be configured for both the 8 × 8 transform and the 4 × 4 transform, and there may be four transform sets. That is, four transform sets may be configured for the 8 × 8 transform, and four transform sets may be configured for the 4 × 4 transform. In this case, each of the four transform sets for the 8 × 8 transform may include two 8x8 transform kernels, and each of the four transform sets for the 4x4 transform may include two 4x4 transform kernels.

10 **[0098]** The sizes of the transforms, the numbers of sets, and the numbers of transform kernels in each set mentioned above are merely for illustration. Instead, a size other than 8x8 or 4x4 may be used, n sets may be configured, and k transform kernels may be included in each set.

15 **[0099]** The transform set may be called an NSST set, and the transform kernel in the NSST set may be called an NSST kernel. The selection of a specific set from among the transform sets may be performed, for example, based on the intra prediction mode of the target block (CU or sub-block).

20 **[0100]** For reference, as an example, the intra prediction mode may include two non-directional (or non-angular) intra prediction modes and 65 directional (or angular) intra prediction modes. The non-directional intra prediction modes may include a No. 0 planar intra prediction mode, and a No. 1 DC intra prediction mode, and the directional intra prediction modes may include 65 intra prediction modes between a No. 2 intra prediction mode and a No. 66 intra prediction mode. However, this is an example, and the present disclosure may be applied to a case where there are different number of intra prediction modes. Meanwhile, according to circumstances, a No. 67 intra prediction mode may be further used, and the No. 67 intra prediction mode may represent a linear model (LM) mode.

25 **[0101]** FIG. 5 illustrates directional intra modes of 65 prediction directions.

30 **[0102]** Referring to FIG. 5, on the basis of the No. 34 intra prediction mode having a left upward diagonal prediction direction, the intra prediction mode having a horizontal directionality and the intra prediction mode having vertical directionality may be classified. H and V of FIG. 5 mean horizontal directionality and vertical directionality, respectively, and numerals -32 to 32 indicate displacements in 1/32 units on the sample grid position. This may represent an offset for the mode index value. The Nos. 2 to 33 intra prediction modes have the horizontal directionality, and the Nos. 34 to 66 intra prediction modes have the vertical directionality. Meanwhile, strictly speaking, the No. 34 intra prediction mode may be considered as being neither horizontal nor vertical, but it may be classified as belonging to the horizontal directionality in terms of determining the transform set of the secondary transform. This is because the input data is transposed to be used for the vertical direction mode symmetrical on the basis of the No. 34 intra prediction mode, and the input data alignment method for the horizontal mode is used for the No. 34 intra prediction mode. Transposing input data means that rows and columns of two-dimensional block data MxN are switched into NxM data. The No. 18 intra prediction mode and the No. 50 intra prediction mode may represent a horizontal intra prediction mode and a vertical intra prediction mode, respectively, and the No. 2 intra prediction mode may be called a right upward diagonal intra prediction mode because it has a left reference pixel and predicts in a right upward direction. In the same manner, the No. 34 intra prediction mode may be called a right downward diagonal intra prediction mode, and the No. 66 intra prediction mode may be called a left downward diagonal intra prediction mode.

40 **[0103]** In one example, four transform sets may be mapped according to an intra prediction mode as in the following table.

[Table 2]

stPredModelIntra	stTrSetIdx
stPredModelIntra < 0	1
0 <= stPredModelIntra <= 1	0
2 <= stPredModelIntra <= 12	1
13 <= stPredModelIntra <= 23	2
24 <= stPredModelIntra <= 44	3
45 <= stPredModelIntra <= 55	2
56 <= stPredModelIntra	1

45 **[0104]** As shown in Table 2, one of the four transform sets, that is, stTrSetIdx, may be mapped to one of four values,

that is, 0 to 3, according to the intra prediction mode.

[0105] When a specific set is determined to be used for the non-separable transform, one of k transform kernels in the specific set may be selected through the non-separable secondary transform index. The encoding apparatus may derive a non-separable secondary transform index indicating a specific transform kernel based on the rate-distortion (RD) check, and may signal the non-separable secondary transform index to the decoding apparatus. The decoding apparatus may select one from among k transform kernels in the specific set based on the non-separable secondary transform index. For example, the NSST index value 0 may indicate a first non-separable secondary transform kernel, the NSST index value 1 may indicate a second non-separable secondary transform kernel, and the NSST index value 2 may indicate a third non-separable secondary transform kernel. Alternatively, the NSST index value 0 may indicate that the first non-separable secondary transform is not applied to a target block, and the NSST index values 1 to 3 may indicate the three transform kernels.

[0106] The transformer may perform the non-separable secondary transform based on the selected transform kernels, and may obtain modified (secondary) transform coefficients. As described above, the modified transform coefficients may be derived as transform coefficients quantized through the quantizer, and may be encoded and signaled to the decoding apparatus and transferred to the dequantizer/inverse transformer in the encoding apparatus.

[0107] Meanwhile, as described above, if the secondary transform is omitted, (primary) transform coefficients, which are an output of the primary (separable) transform, may be derived as transform coefficients quantized through the quantizer as described above, and may be encoded and signaled to the decoding apparatus and transferred to the dequantizer/inverse transformer in the encoding apparatus.

[0108] The inverse transformer may perform a series of procedures in the inverse order to that in which they have been performed in the above-described transformer. The inverse transformer may receive (dequantized) transformer coefficients, and derive (primary) transform coefficients by performing a secondary (inverse) transform (S450), and may obtain a residual block (residual samples) by performing a primary (inverse) transform on the (primary) transform coefficients (S460). In this connection, the primary transform coefficients may be called modified transform coefficients from the viewpoint of the inverse transformer. As described above, the encoding apparatus and the decoding apparatus may generate the reconstructed block based on the residual block and the predicted block, and may generate the reconstructed picture based on the reconstructed block.

[0109] The decoding apparatus may further include a secondary inverse transform application determinator (or an element to determine whether to apply a secondary inverse transform) and a secondary inverse transform determinator (or an element to determine a secondary inverse transform). The secondary inverse transform application determinator may determine whether to apply a secondary inverse transform. For example, the secondary inverse transform may be an NSST or an RST, and the secondary inverse transform application determinator may determine whether to apply the secondary inverse transform based on a secondary transform flag obtained by parsing the bitstream. In another example, the secondary inverse transform application determinator may determine whether to apply the secondary inverse transform based on a transform coefficient of a residual block.

[0110] The secondary inverse transform determinator may determine a secondary inverse transform. In this case, the secondary inverse transform determinator may determine the secondary inverse transform applied to the current block based on an NSST (or RST) transform set specified according to an intra prediction mode. In an embodiment, a secondary transform determination method may be determined depending on a primary transform determination method. Various combinations of primary transforms and secondary transforms may be determined according to the intra prediction mode. Further, in an example, the secondary inverse transform determinator may determine a region to which a secondary inverse transform is applied based on the size of the current block.

[0111] Meanwhile, as described above, if the secondary (inverse) transform is omitted, (dequantized) transform coefficients may be received, the primary (separable) inverse transform may be performed, and the residual block (residual samples) may be obtained. As described above, the encoding apparatus and the decoding apparatus may generate the reconstructed block based on the residual block and the predicted block, and may generate the reconstructed picture based on the reconstructed block.

[0112] Meanwhile, in the present disclosure, a reduced secondary transform (RST) in which the size of a transform matrix (kernel) is reduced may be applied in the concept of NSST in order to reduce the amount of computation and memory required for the non-separable secondary transform.

[0113] Meanwhile, the transform kernel, the transform matrix, and the coefficient constituting the transform kernel matrix, that is, the kernel coefficient or the matrix coefficient, described in the present disclosure may be expressed in 8 bits. This may be a condition for implementation in the decoding apparatus and the encoding apparatus, and may reduce the amount of memory required to store the transform kernel with a performance degradation that can be reasonably accommodated compared to the existing 9 bits or 10 bits. In addition, the expressing of the kernel matrix in 8 bits may allow a small multiplier to be used, and may be more suitable for single instruction multiple data (SIMD) instructions used for optimal software implementation.

[0114] In the present specification, the term "RST" may mean a transform which is performed on residual samples for

a target block based on a transform matrix whose size is reduced according to a reduced factor. In the case of performing the reduced transform, the amount of computation required for transform may be reduced due to a reduction in the size of the transform matrix. That is, the RST may be used to address the computational complexity issue occurring at the non-separable transform or the transform of a block of a great size.

5 [0115] RST may be referred to as various terms, such as reduced transform, reduced secondary transform, reduction transform, simplified transform, simple transform, and the like, and the name which RST may be referred to as is not limited to the listed examples. Alternatively, since the RST is mainly performed in a low frequency region including a non-zero coefficient in a transform block, it may be referred to as a Low-Frequency Non-Separable Transform (LFNST).

10 [0116] Meanwhile, when the secondary inverse transform is performed based on RST, the inverse transformer 235 of the encoding apparatus 200 and the inverse transformer 322 of the decoding apparatus 300 may include an inverse reduced secondary transformer which derives modified transform coefficients based on the inverse RST of the transform coefficients, and an inverse primary transformer which derives residual samples for the target block based on the inverse primary transform of the modified transform coefficients. The inverse primary transform refers to the inverse transform of the primary transform applied to the residual. In the present disclosure, deriving a transform coefficient based on a transform may refer to deriving a transform coefficient by applying the transform.

[0117] FIG. 6 is a diagram illustrating an RST according to an embodiment of the present disclosure.

[0118] In the present disclosure, a "target block" may refer to a current block to be coded, a residual block, or a transform block.

20 [0119] In the RST according to an example, an N-dimensional vector may be mapped to an R-dimensional vector located in another space, so that the reduced transform matrix may be determined, where R is less than N. N may mean the square of the length of a side of a block to which the transform is applied, or the total number of transform coefficients corresponding to a block to which the transform is applied, and the reduced factor may mean an R/N value. The reduced factor may be referred to as a reduced factor, reduction factor, simplified factor, simple factor or other various terms. Meanwhile, R may be referred to as a reduced coefficient, but according to circumstances, the reduced factor may mean R. Further, according to circumstances, the reduced factor may mean the N/R value.

25 [0120] In an example, the reduced factor or the reduced coefficient may be signaled through a bitstream, but the example is not limited to this. For example, a predefined value for the reduced factor or the reduced coefficient may be stored in each of the encoding apparatus 200 and the decoding apparatus 300, and in this case, the reduced factor or the reduced coefficient may not be signaled separately.

30 [0121] The size of the reduced transform matrix according to an example may be R×N less than N × N, the size of a conventional transform matrix, and may be defined as in Equation 4 below.

[Equation 4]

35

$$T_{R \times N} = \begin{bmatrix} t_{11} & t_{12} & t_{13} & \dots & t_{1N} \\ t_{21} & t_{22} & t_{23} & \dots & t_{2N} \\ \vdots & \vdots & \vdots & \ddots & \vdots \\ t_{R1} & t_{R2} & t_{R3} & \dots & t_{RN} \end{bmatrix}$$

40

[0122] The matrix T in the Reduced Transform block shown in FIG. 6A may mean the matrix TR×N of Equation 4. As shown in FIG. 6A, when the reduced transform matrix TR×N is multiplied to residual samples for the target block, transform coefficients for the target block may be derived.

45 [0123] In an example, if the size of the block to which the transform is applied is 8x8 and R =16 (i.e., R/N = 16/64 = 1/4), then the RST according to FIG. 6A may be expressed as a matrix operation as shown in Equation 5 below. In this case, memory and multiplication calculation can be reduced to approximately 1/4 by the reduced factor.

[0124] In the present disclosure, a matrix operation may be understood as an operation of multiplying a column vector by a matrix, disposed on the left of the column vector, to obtain a column vector.

50

55

[Equation 5]

$$\begin{matrix} 5 \\ \\ \\ 10 \end{matrix}
 \begin{bmatrix} t_{1,1} & t_{1,2} & t_{1,3} & \dots & t_{1,64} \\ t_{2,1} & t_{2,2} & t_{2,3} & \dots & t_{2,64} \\ & \vdots & & \ddots & \vdots \\ t_{16,1} & t_{16,2} & t_{16,3} & \dots & t_{16,64} \end{bmatrix} \times \begin{bmatrix} r_1 \\ r_2 \\ \vdots \\ r_{64} \end{bmatrix}$$

[0125] In Equation 5, r1 to r64 may represent residual samples for the target block and may be specifically transform coefficients generated by applying a primary transform. As a result of the calculation of Equation 5, transform coefficients ci for the target block may be derived, and a process of deriving ci may be as in Equation 6.

[Equation 6]

```

20
    for i from 1 to R:
        ci = 0
25
        for j from 1 to N
            ci += tj * rj
30

```

[0126] As a result of the calculation of Equation 6, transform coefficients c1 to cR for the target block may be derived. That is, when R=16, transform coefficients c1 to c16 for the target block may be derived. If, instead of RST, a regular transform is applied and a transform matrix of 64x64 (N x N) size is multiplied to residual samples of 64x1 (Nx1) size, then only 16 (R) transform coefficients are derived for the target block because RST was applied, although 64 (N) transform coefficients are derived for the target block. Since the total number of transform coefficients for the target block is reduced from N to R, the amount of data transmitted by the encoding apparatus 200 to the decoding apparatus 300 decreases, so efficiency of transmission between the encoding apparatus 200 and the decoding apparatus 300 can be improved.

[0127] When considered from the viewpoint of the size of the transform matrix, the size of the regular transform matrix is 64x64 (N x N), but the size of the reduced transform matrix is reduced to 16x64 (RxN), so memory usage in a case of performing the RST can be reduced by an R/N ratio when compared with a case of performing the regular transform. In addition, when compared to the number of multiplication calculations N x N in a case of using the regular transform matrix, the use of the reduced transform matrix can reduce the number of multiplication calculations by the R/N ratio (RxN).

[0128] In an example, the transformer 232 of the encoding apparatus 200 may derive transform coefficients for the target block by performing the primary transform and the RST-based secondary transform on residual samples for the target block. These transform coefficients may be transferred to the inverse transformer of the decoding apparatus 300, and the inverse transformer 322 of the decoding apparatus 300 may derive the modified transform coefficients based on the inverse reduced secondary transform (RST) for the transform coefficients, and may derive residual samples for the target block based on the inverse primary transform for the modified transform coefficients.

[0129] The size of the inverse RST matrix TNxR according to an example is NxR less than the size N x N of the regular inverse transform matrix, and is in a transpose relationship with the reduced transform matrix TRxN shown in Equation 4.

[0130] The matrix Tt in the Reduced Inv. Transform block shown in FIG. 6B may mean the inverse RST matrix TRxNT (the superscript T means transpose). When the inverse RST matrix TRxNT is multiplied to the transform coefficients for the target block as shown in FIG. 6B, the modified transform coefficients for the target block or the residual samples for the target block may be derived. The inverse RST matrix TRxNT may be expressed as (TRxNT)NxR.

[0131] More specifically, when the inverse RST is applied as the secondary inverse transform, the modified transform

coefficients for the target block may be derived when the inverse RST matrix TRxNT is multiplied to the transform coefficients for the target block. Meanwhile, the inverse RST may be applied as the inverse primary transform, and in this case, the residual samples for the target block may be derived when the inverse RST matrix TRxNT is multiplied to the transform coefficients for the target block.

5 **[0132]** In an example, if the size of the block to which the inverse transform is applied is 8x8 and R =16 (i.e., R/N = 16/64 = 1/4), then the RST according to FIG. 6B may be expressed as a matrix operation as shown in Equation 7 below.

[Equation 7]

$$\begin{matrix}
 10 \\
 15 \\
 20
 \end{matrix}
 \begin{bmatrix}
 t_{1,1} & t_{2,1} & & t_{16,1} \\
 t_{1,2} & t_{2,2} & \dots & t_{16,2} \\
 t_{1,3} & t_{2,3} & & t_{16,3} \\
 \vdots & \vdots & & \vdots \\
 & \vdots & \ddots & \vdots \\
 t_{1,64} & t_{2,64} & \dots & t_{16,64}
 \end{bmatrix}
 \times
 \begin{bmatrix}
 c_1 \\
 c_2 \\
 \vdots \\
 c_{16}
 \end{bmatrix}$$

[0133] In Equation 7, c1 to c16 may represent the transform coefficients for the target block. As a result of the calculation of Equation 7, rj representing the modified transform coefficients for the target block or the residual samples for the target block may be derived, and the process of deriving rj may be as in Equation 8.

25

[Equation 8]

```

30
    for i from 1 to N:
        ri = 0
35
        for j from 1 to R
            ri += tij * cj
40

```

[0134] As a result of the calculation of Equation 8, r1 to rN representing the modified transform coefficients for the target block or the residual samples for the target block may be derived. When considered from the viewpoint of the size of the inverse transform matrix, the size of the regular inverse transform matrix is 64x64 (NxN), but the size of the reduced inverse transform matrix is reduced to 64x16 (RxN), so memory usage in a case of performing the inverse RST can be reduced by an R/N ratio when compared with a case of performing the regular inverse transform. In addition, when compared to the number of multiplication calculations N × N in a case of using the regular inverse transform matrix, the use of the reduced inverse transform matrix can reduce the number of multiplication calculations by the R/N ratio (NxR).

45

[0135] A transform set configuration shown in Table 2 may also be applied to an 8x8 RST. That is, the 8x8 RST may be applied according to a transform set in Table 2. Since one transform set includes two or three transforms (kernels) according to an intra prediction mode, it may be configured to select one of up to four transforms including that in a case where no secondary transform is applied. In a transform where no secondary transform is applied, it may be considered to apply an identity matrix. Assuming that indexes 0, 1, 2, and 3 are respectively assigned to the four transforms (e.g., index 0 may be allocated to a case where an identity matrix is applied, that is, a case where no secondary transform is applied), an NSST index as a syntax element may be signaled for each transform coefficient block, thereby designating a transform to be applied. That is, through the NSST index, it is possible to designate an 8x8 NSST for a top-left 8x8 block and to designate an 8x8 RST in an RST configuration. The 8x8 NSST and the 8x8 RST refer to transforms applicable to an 8x8 region included in the transform coefficient block when both W and H of the target block to be transformed

50

55

are equal to or greater than 8, and the 8x8 region may be a top-left 8x8 region in the transform coefficient block. Similarly, a 4x4 NSST and a 4x4 RST refer to transforms applicable to a 4x4 region included in the transform coefficient block when both W and H of the target block to are equal to or greater than 4, and the 4x4 region may be a top-left 4x4 region in the transform coefficient block.

5 **[0136]** According to an embodiment of the present disclosure, for a transform in an encoding process, only 48 pieces of data may be selected and a maximum 16×48 transform kernel matrix may be applied thereto, rather than applying a 16×64 transform kernel matrix to 64 pieces of data forming an 8×8 region. Here, "maximum" means that m has a maximum value of 16 in an $m \times 48$ transform kernel matrix for generating m coefficients. That is, when an RST is performed by applying an $m \times 48$ transform kernel matrix ($m \leq 16$) to an 8×8 region, 48 pieces of data are input and m coefficients are generated. When m is 16, 48 pieces of data are input and 16 coefficients are generated. That is, assuming that 48 pieces of data form a 48×1 vector, a 16×48 matrix and a 48×1 vector are sequentially multiplied, thereby generating a 16×1 vector. Here, the 48 pieces of data forming the 8×8 region may be properly arranged, thereby forming the 48×1 vector. Here, when a matrix operation is performed by applying a maximum 16×48 transform kernel matrix, 16 modified transform coefficients are generated, and the 16 modified transform coefficients may be arranged in a top-left 4x4 region according to a scanning order, and a top-right 4x4 region and a bottom-left 4x4 region may be filled with zeros.

10 **[0137]** For an inverse transform in a decoding process, the transposed matrix of the foregoing transform kernel matrix may be used. That is, when an inverse RST or LFNST is performed in an inverse transform process performed by the decoding apparatus, input coefficient data to which the inverse RST is applied is configured in a one-dimensional vector according to a predetermined arrangement order, and a modified coefficient vector obtained by multiplying the one-dimensional vector and a corresponding inverse RST matrix on the left of the one-dimensional vector may be arranged in a two-dimensional block according to a predetermined arrangement order.

15 **[0138]** In summary, in the transform process, when an RST or LFNST is applied to an 8×8 region, a matrix operation of 48 transform coefficients in top-left, top-right, and bottom-left regions of the 8×8 region excluding the bottom-right region among transform coefficients in the 8×8 region and a 16×48 transform kernel matrix. For the matrix operation, the 48 transform coefficients are input in a one-dimensional array. When the matrix operation is performed, 16 modified transform coefficients are derived, and the modified transform coefficients may be arranged in the top-left region of the 8×8 region.

20 **[0139]** On the contrary, in the inverse transform process, when an inverse RST or LFNST is applied to an 8×8 region, 16 transform coefficients corresponding to a top-left region of the 8×8 region among transform coefficients in the 8×8 region may be input in a one-dimensional array according to a scanning order and may be subjected to a matrix operation with a 48×16 transform kernel matrix. That is, the matrix operation may be expressed as $(48 \times 16 \text{ matrix}) * (16 \times 1 \text{ transform coefficient vector}) = (48 \times 1 \text{ modified transform coefficient vector})$. Here, an $n \times 1$ vector may be interpreted to have the same meaning as an $n \times 1$ matrix and may thus be expressed as an $n \times 1$ column vector. Further, * denotes matrix multiplication. When the matrix operation is performed, 48 modified transform coefficients may be derived, and the 48 modified transform coefficients may be arranged in top-left, top-right, and bottom-left regions of the 8x8 region excluding a bottom-right region.

25 **[0140]** When a secondary inverse transform is based on an RST, the inverse transformer 235 of the encoding apparatus 200 and the inverse transformer 322 of the decoding apparatus 300 may include an inverse reduced secondary transformer to derive modified transform coefficients based on an inverse RST on transform coefficients and an inverse primary transformer to derive residual samples for a target block based on an inverse primary transform on the modified transform coefficients. The inverse primary transform refers to the inverse transform of a primary transform applied to a residual. In the present disclosure, deriving a transform coefficient based on a transform may refer to deriving the transform coefficient by applying the transform.

30 **[0141]** As described above, the encoding apparatus may perform various encoding methods, such as exponential Golomb coding, context-adaptive variable length coding (CAVLC), and context-adaptive binary arithmetic coding (CABAC). In addition, the decoding apparatus may decode information in a bitstream based on a coding method, such as exponential Golomb coding, CAVLC, or CABAC, and may output the value of a syntax element necessary for image reconstruction and quantized values of a transform coefficient regarding a residual.

35 **[0142]** For example, the foregoing coding methods may be performed as described below.

40 **[0143]** FIG. 7 illustrates context-adaptive binary arithmetic coding (CABAC) for encoding a syntax element. For example, in an encoding process of CABAC, the encoding apparatus may convert an input signal to a binary value through binarization when the input signal is a syntax element rather than a binary value. When the input signal is an already binary value (that is, the value of the input signal is a binary value), the input signal is bypassed without binarization. Here, each binary 0 or 1 forming the binary value may be referred to as a bin. For example, when a binary string resulting from the binarization is 110, each of 1, 1, and 0 is called one bin. The bin(s) for one syntax element may indicate the value of the syntax element. The binarization may be based on various binarization methods, such as a truncated Rice binarization process and a fixed-length binarization process, and a binarization method for a target syntax element may

be predefined. This binarization procedure may be performed by a binarizer in the entropy encoder.

[0144] The binarized bins of the syntax element may be input to a regular coding engine or a bypass coding engine. The regular coding engine of the encoding apparatus may assign a context model that reflects a probability value for the bins and may encode the bins based on the assigned context model. The regular coding engine of the encoding apparatus may encode on each bin and may then update the context model for the bin. These encoded bins may be referred to as context-coded bins.

[0145] When the binarized bins of the syntax element are input to the bypass coding engine, the bins may be coded as follows. For example, the bypass coding engine of the encoding apparatus omits a procedure of estimating a probability for the input bins and a procedure of updating a probability model applied to the bins after encoding. When bypass encoding is applied, the encoding apparatus may encode the input bits by applying a uniform probability distribution instead of assigning a context model, thus increasing encoding speed. These coded bins may be referred to as bypass bins.

[0146] Entropy decoding may be performed by the same process as entropy encoding described above in reverse order.

[0147] The decoding apparatus (entropy decoder) may decode encoded image/video information. The image/video information may include partitioning-related information, prediction-related information (e.g., inter/intra prediction classification information, intra prediction mode information, and inter prediction mode information), residual information, in-loop filtering-related information, and the like, or may include various syntax elements relating thereto. The foregoing entropy coding may be performed in syntax element units.

[0148] The decoding apparatus may perform binarization on a target syntax element. Here, the binarization may be based on various binarization methods, such as a truncated Rice binarization process and a fixed-length binarization process, and a binarization method for the target syntax element may be predefined. The decoding apparatus may derive available bin strings (bin string candidates) for available values of the target syntax element through this binarization procedure. The binarization procedure may be performed by a binarizer in the entropy decoder.

[0149] The decoding apparatus sequentially decodes and parses individual bins for the target syntax element from an input bit(s) in a bitstream and compares a derived bin string with the available bin strings for the syntax element. When the derived bin string is the same as one of the available bin strings, a value corresponding to the bin string is derived as the value of the syntax element. Otherwise, the decoding apparatus further parses a next bit in the bitstream and performs the above procedure again. Through this process, specific information (specific syntax element) in the bitstream may be signaled using a variable-length bit without using a start bit or an end bit for the specific information. Accordingly, a smaller number of bits may be allocated to a lower value, and overall coding efficiency may be improved.

[0150] The decoding apparatus may perform context-based or bypass-based decoding on each bin in the bin string from the bitstream based on an entropy coding technique, such as CABAC or CAVLC.

[0151] When the syntax element is decoded based on a context model, the decoding apparatus may receive a bin corresponding to the syntax element through the bitstream, may determine the context model using the syntax element and decoding information on a block to be decoded or a neighboring block or information on a symbol/bin decoded in a previous step, and may derive the value of the syntax element by predicting the probability of the received bin occurring and performing arithmetic decoding of the bin according to the determined context model. Subsequently, a context model for a bin to be subsequently decoded may be updated to the determined context model.

[0152] A context model may be assigned and updated for each bin to be context-coded (regularly coded) and may be indicated based on $ctxIdx$ or $ctxInc$. $ctxIdx$ may be derived based on $ctxInc$. Specifically, for example, a context index ($ctxIdx$) indicating a context model for each regularly coded bin may be derived as the sum of a context index increment ($ctxInc$) and a context index offset ($ctxIdxOffset$). Here, different $ctxInc$ may be derived for each bin. $ctxIdxOffset$ may be expressed as the lowest value of $ctxIdx$. $ctxIdxOffset$ is a value generally used for distinguishing from context models for other syntax elements, and a context model for one syntax element may be classified/derived based on $ctxInc$.

[0153] In entropy encoding, it may be determined whether to perform encoding through the regular coding engine or through the bypass encoding engine, and a coding path may be switched. Entropy decoding may be performed by the same process as encoding in reverse order.

[0154] For example, when the syntax element is subjected to bypass decoding, the decoding apparatus may receive the bin corresponding to the syntax element through the bitstream and may decode the input bin by applying a uniform probability distribution. In this case, the decoding apparatus may omit the procedure of deriving the context model for the syntax element and the procedure of updating the context model applied to the bin after decoding.

[0155] As described above, residual samples may be derived as quantized transform coefficients through transform and quantization processes. The quantized transform coefficients may also be referred to as transform coefficients. In this case, the transform coefficients within a block may be signaled in the form of residual information. The residual information may include a residual coding syntax. That is, the encoding apparatus may construct the residual coding syntax with the residual information, may encode the residual coding syntax, and may output residual coding syntax in the form of a bitstream, and the decoding apparatus may decode the residual coding syntax from the bitstream and may derive residual (quantized) transform coefficients. As described below, the residual coding syntax may include syntax

elements indicating whether a transform is applied to the block, the position of the last significant transform coefficient in the block, whether there is a significant transform coefficient in a subblock, the size/code of a significant transform coefficient, and the like.

[0156] According to an example, a method for binarization and context modeling of information indicating a secondary transform kernel (e.g., transform index `st_idx`) may be proposed.

[0157] Table 3 shows part of the syntax of a TU according to an example, and Table 4 shows part of the syntax of a coding unit.

[Table 3]

7.3.4.11 Transform unit syntax

15	<code>if(tu_cbf_luma[x0][y0] && treeType != DUAL_TREE_CHROMA</code>	
	<code>&& (tbWidth <= 32) && (tbHeight <= 32)</code>	
	<code>&& (IntraSubPartitionsSplit[x0][y0] == ISP_NO_SPLIT) && (!cu_sbt_flag)) {</code>	
20	<code>if(transform_skip_enabled_flag &&</code>	
	<code>log2TbWidth <= MaxTsSize && log2TbHeight <= MaxTsSize</code>	
	<code>transform_skip_flag[x0][y0]</code>	ae(v)
25	<code>if((CuPredMode[x0][y0] == MODE_INTER && sps_mts_inter_enabled_flag) </code>	
	<code>(CuPredMode[x0][y0] == MODE_INTRA && sps_mts_intra_enabled_flag) &&</code>	
	<code>(tbWidth <= 32) && (tbHeight <= 32) && (!transform_skip_flag[x0][y0]))</code>	
	<code>tu_mts_idx[x0][y0]</code>	ae(v)
	<code>}</code>	
	<code>if(tu_cbf_luma[x0][y0])</code>	
	<code>residual_coding(x0, y0, Log2(tbWidth), Log2(tbHeight), 0)</code>	
30	<code>if(tu_cbf_cb[x0][y0])</code>	
	<code>residual_coding(xC, yC, Log2(wC), Log2(hC), 1)</code>	
	<code>if(tu_cbf_cr[x0][y0])</code>	
	<code>residual_coding(xC, yC, Log2(wC), Log2(hC), 2)</code>	
35	<code>}</code>	

[Table 4]

7.3.6.5 Coding unit syntax

5	<code>numZeroOutSigCoeff = 0</code>	
	<code>transform_tree(x0, y0, cbWidth, cbHeight, treeType)</code>	
10	<code>if(Min(cbWidth, cbHeight) >= 4 && sps_st_enabled_flag == 1 && CuPredMode[x0][y0] == MODE_INTRA && IntraSubPartitionsSplitType == ISP_NO_SPLIT) {</code>	
	<code>if((numSigCoeff > ((treeType == SINGLE_TREE) ? 2 : 1)) && numZeroOutSigCoeff == 0) {</code>	
15	<code>st_idx[x0][y0]</code>	<code>ae(v)</code>
	<code>}</code>	
	<code>}</code>	
	<code>}</code>	
20	<code>}</code>	

7.4.7.5 Coding unit semantics

.....

25 `st_idx[x0][y0]` specifies which secondary transform kernel is applied between two candidate kernels in a selected transform set. `st_idx[x0][y0]` equal to 0 specifies that the secondary transform is not applied. The array indices `x0, y0` specify the location (`x0, y0`) of the top-left sample of the considered transform block relative to the top-left sample of the picture.

30 When `st_idx[x0][y0]` is not present, `st_idx[x0][y0]` is inferred to be equal to 0.

35 **[0158]** In Table 3, `tu_mts_idx[x0][y0]` denotes an MTS index applied to a transform block, and `trTypeHor` and `trTypeVer` may be determined according to the MTS index as shown in Table 1.

[0159] As shown in Table 4, the transform index (`st_idx`) indicates a secondary transform kernel matrix indicating any one of two candidate transform kernels included in a selected transform set. A transform index of 0 indicates that a secondary transform is not applied. The transform index may be mapped to an intra prediction mode as shown in Table 2 and may be derived based on the selected transform set.

40 **[0160]** As described above, the binary value of each position of a binary string is referred to as a bin, and each bin of the binary string is may be coded by context-adaptive binary arithmetic coding (CABAC) of coding with designated context or by bypass coding. Bypass coding is a coding scheme of assigning a probability of 0.5 without context, and CABAC, which may be referred to as regular coding, is a coding scheme of obtaining a probability value to be applied to coding from context information, that is, probability information.

45 **[0161]** When CABAC is used, M pieces of context information may be used to code N bins, and each piece of context information may be applied to coding of one bin at a specific position or may be applied to coding of a plurality of bins at a plurality of positions. Here, M may be the same as or less than N.

[0162] Each context may be updated through a method applied in a codec (e.g., HEVC or VVC) using CABAC, and regular coding described above may also follow the method applied in the existing codec.

50 **[0163]** For example, when the index has values of 0, 1, and 2, which are assigned corresponding binary codes of 0, 10, and 11, respectively, a total of two pieces of context information may be applied by assigning context information to each bin. That is, context A may be applied when coding a first bin, and context B may be applied when coding a second bin.

[0164] Table 5 and Table 6 show a process of deriving the context increment (`ctxInc`) of the transformation index.

[Table 5]

Syntax elements and associated binarizations			
Syntax structure	Syntax element	Binarization	
		Process	Input parameters
.....
.....	st_idx[][]	TR	cMax = 2, cRiceParam = 0

[Table 6]

Assignment of ctxInc to syntax elements with context coded bins						
Syntax element	binIdx					
	0	1	2	3	4	>= 5
.....
st_idx[][]	0,1,4,5 (clause 9.5.4.2.8)	2,3,6,7 (clause 9.5.4.2.8)	na	na	na	na
.....

9.5.4.2.8 Derivation process of ctxInc for the syntax element st_idx

Inputs to this process are the colour component index cIdx, the luma or chroma location (x0, y0) specifying the top-left sample of the current luma or chroma coding block relative to the top-left sample of the current picture depending on cIdx, the tree type treeType, the luma intra prediction mode IntraPredModeY[x0][y0] as specified in clause 8.4.2, the syntax element intra_chroma_pred_mode[x0][y0] specifying the intra prediction mode for chroma samples as specified in clause 7.4.7.5, and the multiple transform selection index tu_mts_idx[x0][y0].

Output of this process is the variable ctxInc.

The variable intraModeCtx is derived as follows:

- If cIdx is equal to 0, intraModeCtx is derived as follows:
intraModeCtx = (IntraPredModeY[x0][y0] <= 1) ? 1 : 0
- Otherwise (cIdx is greater than 0), intraModeCtx is derived as follows:
intraModeCtx = (intra_chroma_pred_mode[x0][y0] >= 4) ? 1 : 0

The variable mtsCtx is derived as follows:

$$mtsCtx = (tu_mts_idx[x0][y0] > 0 \ \&\& \ treeType \neq \ SINGLE_TREE) ? 1 : 0$$

The variable ctxInc is derived as follows:

$$ctxInc = (binIdx \ll 1) + intraModeCtx + (mtsCtx \ll 2)$$

[0165] Table 5 shows that when binarization of the transform index is performed by truncated Rice binarization, the maximum value of the index is 2. Further, since cRiceParam is 0, the binarization is performed by truncated unary binarization.

[0166] Table 6 shows that the ctxInc value of a context-coded bin is derived. As shown in Table 6, the first bin of the

transform index may be derived based on any one of four ctxInc values (0, 1, 4, 5), and the second bin may also be derived based on any one of four ctxInc values (2, 3, 6, 7).

[0167] According to Table 6, when a color index (cIdx), the top-left position of a current coding block, the tree type of the current block, an intra prediction mode, and the MTS index (tu_mts_idx[x0][y0].) are input, the ctxInc value may be derived based on a variable mtsCtx. The tree type may be classified as a single tree (SINGLE_TREE) type or a dual tree (DUAL_TREE) type according to whether a chroma block corresponding to a luma block has a separate partitioning structure. When the chroma block has the same partitioning structure as that of the luma block, the tree type may be a single tree, and when the chroma block has a different partitioning structure from that of the luma block, the tree type may be a dual tree.

[0168] The variable mtsCtx may be derived as 1 when the MTS index is greater than 0 and the tree type is not the single tree type, and may be derived as 0 otherwise, that is, when the MTS index is 0 or the tree type is the single tree type ((tu_mts_idx[x0][y0] > 0 && treeType != SINGLE_TREE) ? 1 : 0). ctxInc may be derived based on the variable mtsCtx value (ctxInc = (binIdx << 1) + intraModeCtx + (mtsCtx << 2)).

[0169] Alternatively, according to another example, the ctxInc value of the context-coded bin of the transform index may be derived as shown in the following table.

[Table 7]

Assignment of ctxInc to syntax elements with context coded bins						
Syntax element	binIdx					
	0	1	2	3	4	>= 5
.....
st_idx[][]	0,1 (clause 9.5.4.2.8)	bypass	na	na	na	na
.....

9.5.4.2.8 Derivation process of ctxInc for the syntax element st_idx

Inputs to this process are the colour component index cIdx, the luma or chroma location (x0, y0) specifying the top-left sample of the current luma or chroma coding block relative to the top-left sample of the current picture depending on cIdx, the tree type treeType, and the multiple transform selection index tu_mts_idx[x0][y0].

Output of this process is the variable ctxInc.

The variable ctxInc is derived as follows:

$$ctxInc = (tu_mts_idx[x0][y0] > 0 \&\& treeType != SINGLE_TREE) ? 1 : 0$$

[0170] Table 7 also shows a process of deriving ctxInc of the transform index. According to Table 7, the first bin may be derived based on one of two ctxInc values (0, 1), and the second bin may be derived based on bypass coding rather than a context model. For the first bin (bin with binIdx = 0) to which context-based coding is applied, only two contexts may be assigned, and a ctxInc value regarding which of the two contexts to select may be determined as in Section 9.5.4.2.8.

[0171] That is, the variable ctxInc for the first bin of the transform index may be derived as 1 when the MTS index is greater than 0 and the tree type is not the single tree type, and may be derived as 0 otherwise, that is, when the MTS index is 0 or the tree type is the single tree type ((tu_mts_idx[x0][y0] > 0 && treeType != SINGLE_TREE) ? 1 : 0). According to this embodiment, ctxInc may be directly derived according to the MTS index and the tree type without being based on the value of another variable, for example, an intermediate variable including mtsCtx in Table 6.

[0172] Alternatively, according to an example, Table 7 may be expressed in a different manner as shown in Table 8. Although Table 8 omits Section 9.5.4.2.8 included in Table 7, a description of a process of deriving ctxInc of the transform index is the same as that of Table 7.

5

[Table 8]

10

Assignment of ctxInc to syntax elements with context coded bins

15

20

Syntax element	binIdx					
	0	1	2	3	4	≥ 5
.....
st_idx[][]	(tu_mts_idx[][] > 0 && treeType != SINGLE_TREE) ? 1 : 0	bypass	na	na	na	na
.....

25

[0173] According to another example, the ctxInc value of the context-coded bin of the transform index may be derived as shown in the following table.

30

35

40

45

50

55

[Table 9]

Assignment of ctxInc to syntax elements with context coded bins						
Syntax element	binIdx					
	0	1	2	3	4	>= 5
.....
st_idx[][]	0,1,4,5 (clause 9.5.4.2.8)	2,3,6,7 (clause 9.5.4.2.8)	na	na	na	na
.....

9.5.4.2.8 Derivation process of ctxInc for the syntax element st_idx

Inputs to this process are the colour component index cIdx, the luma or chroma location (x0, y0) specifying the top-left sample of the current luma or chroma coding block relative to the top-left sample of the current picture depending on cIdx, the tree type treeType, the luma intra prediction mode IntraPredModeY[x0][y0] as specified in clause 8.4.2, the syntax element intra_chroma_pred_mode[x0][y0] specifying the intra prediction mode for chroma samples as specified in clause 7.4.7.5, and the multiple transform selection index tu_mts_idx[x0][y0].

Output of this process is the variable ctxInc.

The variable intraModeCtx is derived as follows:

- If cIdx is equal to 0, intraModeCtx is derived as follows:

$$\text{intraModeCtx} = (\text{IntraPredModeY}[x0][y0] \leq 1) ? 1 : 0$$
- Otherwise (cIdx is greater than 0), intraModeCtx is derived as follows:

$$\text{intraModeCtx} = (\text{intra_chroma_pred_mode}[x0][y0] \geq 4) ? 1 : 0$$

The variable mtsCtx is derived as follows:

$$\text{mtsCtx} = (\text{tu_mts_idx}[x0][y0] = 0 \ \&\& \ \text{treeType} \neq \text{SINGLE_TREE}) ? 1 : 0$$

The variable ctxInc is derived as follows:

$$\text{ctxInc} = (\text{binIdx} \ll 1) + \text{intraModeCtx} + (\text{mtsCtx} \ll 2)$$

[0174] Table 9 shows that the ctxInc value of a context-coded bin is derived. As shown in Table 9, the first bin of the transform index may be derived based on any one of four ctxInc values (0, 1, 4, 5), and the second bin may also be derived based on any one of four ctxInc values (2, 3, 6, 7).

[0175] According to Table 9, when a color index (cIdx), the top-left position of a current coding block, the tree type of the current block, an intra prediction mode, and an MTS index (tu_mts_idx[x0][y0].) are input, the ctxInc value may be derived based on a variable mtsCtx.

[0176] The variable mtsCtx may be derived as 1 when the MTS index is 0 and the tree type is not the single tree type, and may be derived as 0 otherwise, that is, when the MTS index is not 0 or the tree type is the single tree type ((tu_mts_idx[x0][y0] = 0 && treeType != SINGLE_TREE) ? 1 : 0). ctxInc may be derived based on the variable mtsCtx value (ctxInc = (binIdx << 1) + intraModeCtx + (mtsCtx << 2)).

[0177] Alternatively, according to another example, the ctxInc value of the context-coded bin of the transform index may be derived as shown in the following table.

[Table 10]

Assignment of ctxInc to syntax elements with context coded bins						
Syntax element	binIdx					
	0	1	2	3	4	>= 5
.....
st_idx[][]	0,1 (clause 9.5.4.2.8)	bypass	na	na	na	na
.....

9.5.4.2.8 Derivation process of ctxInc for the syntax element st_idx
 Inputs to this process are the colour component index cIdx, the luma or chroma location (x0, y0) specifying the top-left sample of the current luma or chroma coding block relative to the top-left sample of the current picture depending on cIdx, the tree type treeType, and the multiple transform selection index tu_mts_idx[x0][y0].
 Output of this process is the variable ctxInc.
 The variable ctxInc is derived as follows:

$$ctxInc = (tu_mts_idx[x0][y0] == 0 \ \&\& \ treeType \neq SINGLE_TREE) ? 1 : 0$$

[0178] Table 10 also shows a process of deriving ctxInc of the transform index. According to Table 10, the first bin may be derived based on one of two ctxInc values (0, 1), and the second bin may be derived based on bypass coding rather than a context model. For the first bin (bin with binIdx = 0) to which context-based coding is applied, only two contexts may be assigned, and a ctxInc value regarding which of the two contexts to select may be determined as in Section 9.5.4.2.8.

[0179] That is, the variable ctxInc for the first bin of the transform index may be derived as 1 when the MTS index is 0 and the tree type is not the single tree type, and may be derived as 0 otherwise, that is, when the MTS index is not 0 or the tree type is the single tree type ((tu_mts_idx[x0][y0] = 0 && treeType != SINGLE_TREE) ? 1: 0). According to this embodiment, ctxInc may be directly derived according to the MTS index and the tree type without being based on the value of another variable, for example, an intermediate variable including mtsCtx in Table 9.

[0180] Alternatively, according to an example, Table 10 may be expressed in a different manner as shown in Table 11. Although Table 11 omits Section 9.5.4.2.8 included in Table 10, a description of a process of deriving ctxInc of the transform index is the same as that of Table 10.

[Table 11]

Assignment of ctxInc to syntax elements with context coded bins						
Syntax element	binIdx					
	0	1	2	3	4	>= 5
.....
st_idx[][]	(tu_mts_idx[][] == 0 && treeType != SINGLE_TREE) ? 1 : 0	bypass	na	na	na	na
.....

5 **[0181]** According to an example, with the MTS index not being received, the decoding apparatus may decode the transform index. In this case, when the MTS index is not received, the MTS index may be inferred as 0, and the processes of Table 9 to Table 11 may be applied. That is, when the MTS index has not been received or decoded, the MTS index may be inferred as 0, and the context information on the first bin of the transform index may be derived as 1, when the tree type of the target block is not a single tree type, and may be derived as 0, when the tree type of the target block is the single tree type.

10 **[0182]** Similarly, with the MTS index not being coded, the encoding apparatus may code the transform index. In this case, when the MTS index is not coded, the MTS index may be inferred as 0, and the processes of Table 9 to Table 11 may be applied. That is, when the MTS index has not been generated or encoded, the MTS index may be inferred as 0, and the context information on the first bin of the transform index may be derived as 1, when the tree type of the target block is not the single tree type, and may be derived as 0, when the tree type of the target block is the single tree type.

15 **[0183]** According to an example, both the first bin and the second bin of the transform index may be coded based on a context model. That is, first context model information may be used for the first bin, and second context model information may be used for the second bin. Here, the context information may be ctxInc or may be derived based on ctxInc, and the first context model information and the second context model information may have different values. According to an example, the first context model information may be 0 or 1 according to the tree type of the target block to be transformed, and the second context model information may be set to a specific value regardless of the tree type.

20 **[0184]** Here, the first context model information may be derived as 1 when the MTS index is 0 and the tree type is not the single tree type, and may be derived as 0 otherwise, that is, when the MTS index is not 0 or the tree type is the single tree type. Alternatively, according to another example, the first context model information may be derived as 0 or 1 according to the tree type regardless of the MTS index. That is, the first context model information may be derived as 1 when the tree type of the target block is not the single tree type, and may be derived as 0 when the tree type of the target block is the single tree type.

25 **[0185]** The following drawings are provided to describe specific examples of the present disclosure. Since the specific designations of devices or the designations of specific signals/messages/fields illustrated in the drawings are provided for illustration, technical features of the present disclosure are not limited to specific designations used in the following drawings.

30 **[0186]** FIG. 8 is a flowchart illustrating an operation of a video decoding apparatus according to an embodiment of the present disclosure.

35 **[0187]** Each operation illustrated in FIG. 8 may be performed by the decoding apparatus 300 illustrated in FIG. 3. Specifically, S810 may be performed by the entropy decoder 310 illustrated in FIG. 3, S820 may be performed by the dequantizer 321 illustrated in FIG. 3, S830 and S840 may be performed by the inverse transformer 322 illustrated in FIG. 3, and S850 may be performed by the adder 340 illustrated in FIG. 3. Operations according to S810 to S850 are based on some of the foregoing details explained with reference to FIG. 4 to FIG. 7. Therefore, a description of specific details overlapping with those explained above with reference to FIG. 4 to FIG. 7 will be omitted or will be made briefly.

40 **[0188]** The decoding apparatus 300 according to an embodiment may derive quantized transform coefficients for a target block from a bitstream (S810). Specifically, the decoding apparatus 300 may decode information on the quantized transform coefficients for the target block from the bitstream and may derive the quantized transform coefficients for the target block based on the information on the quantized transform coefficients for the target block. The information on the quantized transform coefficients for the target block may be included in a sequence parameter set (SPS) or a slice header and may include at least one of information on whether a reduced transform (RST) is applied, information on a reduced factor, information on a minimum transform size to which the RST is applied, information on a maximum transform size to which the RST is applied, information on a reduced inverse transform size, and information on a transform index indicating any one of transform kernel matrices included in a transform set.

45 **[0189]** The decoding apparatus 300 according to an embodiment may derive transform coefficients by dequantizing the quantized transform coefficients for the target block (S820).

[0190] The decoding apparatus 300 according to an embodiment may derive modified transform coefficients based on an inverse non-separable transform or an inverse reduced secondary transform (RST) of the transform coefficients (S830).

50 **[0191]** In an example, the inverse non-separable transform or the inverse RST may be performed based on an inverse RST transform matrix, and the inverse RST transform matrix may be a nonsquare matrix in which the number of columns is less than the number of rows.

55 **[0192]** In an embodiment, S830 may include decoding a transform index, determining whether a condition for applying an inverse RST is satisfied based on the transform index, selecting a transform kernel matrix, and applying the inverse RST to the transform coefficients based on the selected transform kernel matrix and/or the reduced factor when the condition for applying the inverse RST is satisfied. In this case, the size of an inverse RST matrix may be determined based on the reduced factor.

[0193] The decoding apparatus 300 according to an embodiment may derive residual samples for the target block

based on an inverse transform of the modified transform coefficients (S840).

[0194] The decoding apparatus 300 may perform an inverse primary transform on the modified transform coefficients for the target block, in which case a reduced inverse transform may be applied or a conventional separable transform may be used as the inverse primary transform.

[0195] The decoding apparatus 300 according to an embodiment may generate reconstructed samples based on the residual samples for the target block and prediction samples for the target block (S850).

[0196] Referring to S830, it may be identified that the residual samples for the target block are derived based on the inverse RST of the transform coefficients for the target block. From the perspective of the size of the inverse transform matrix, since the size of a regular inverse transform matrix is $N \times N$ but the size of the inverse RST matrix is reduced to $N \times R$, it is possible to reduce memory usage in a case of performing the inverse RST by an R/N ratio compared to that in a case of performing a regular transform. Further, using the inverse RST matrix can reduce the number of multiplications ($N \times R$) by the R/N ratio, compared to the number of multiplications $N \times N$ in a case of using the regular inverse transform matrix. In addition, since only R transform coefficients need to be decoded when the inverse RST is applied, the total number of transform coefficients for the target block may be reduced from N to R , compared to that in a case where N transform coefficients need to be decoded when a regular inverse transform is applied, thus increasing decoding efficiency. That is, according to S830, the (inverse) transform efficiency and decoding efficiency of the decoding apparatus 300 may be increased through the inverse RST.

[0197] FIG. 9 is a control flowchart illustrating an inverse non-separable transform method based on a transform index according to an embodiment of the present disclosure.

[0198] The decoding apparatus 300 receives information on a transform index and an intra prediction mode from a bitstream (S900). The decoding apparatus 300 may further receive MTS index information indicating a transform kernel of an inverse primary transform.

[0199] The information on the transform index is received as syntax information, and the syntax information is received as a bin string including a 0 and a 1.

[0200] The entropy decoder 310 may derive binarization information on a syntax element of the transform index.

[0201] This operation is generating a candidate set for a binary value that the syntax element of the received transform index can have. According to this embodiment, the syntax element of the transform index may be binarized by truncated unary coding.

[0202] The syntax element of the transform index according to this embodiment may indicate whether an inverse RST or an inverse non-separable transform is applied and one of transform kernel matrices included in a transform set. When the transform set includes two transform kernel matrices, the syntax element of the transform index may have three values.

[0203] That is, according to an embodiment, the value of the syntax element of the transform index may include 0 indicating that the inverse RST is not applied to a target block, 1 indicating a first transform kernel matrix of the transform kernel matrices, and 2 indicating a second transform kernel matrix of the transform kernel matrices.

[0204] In this case, the three values of the syntax element of the transform index may be coded into 0, 10, and 11, respectively, according to truncated unary coding. That is, the value of the syntax element of 0 may be binarized into '0', the value of the syntax element of 1 may be binarized into '10', and the value of the syntax element of 2 may be binarized into '11'.

[0205] The entropy decoder 310 may derive context information, that is, a context model, on the bin string of the transform index according to the value of an MTS index and the tree type of a target block (S910) and may decode bins of the bin string of the syntax element based on the context information (S920).

[0206] According to this embodiment, different pieces of context information, that is, different probability models, may be applied to two bins of the transform index, respectively. That is, all of the two bins of the transform index may be decoded by a context method rather than by a bypass method, wherein a first bin of the bins of the syntax element of the transform index may be decoded based on first context information, and a second bin of the bins of the syntax element of the transform index may be decoded based on second context information.

[0207] According to another embodiment, the first bin of the two bins of the transform index may be decoded by the context method, and the second bin may be decoded by the bypass method.

[0208] The context information, particularly, the first context information on the first bin, may be derived as a different value depending on the value of the MTS index and the tree type of the target block.

[0209] For example, the tree type of the target block may be classified as a single tree (SINGLE_TREE) or a dual tree (DUAL_TREE) according to whether a chroma block corresponding to a luma block has a separate partitioning structure. When the chroma block has the same partitioning structure as that of the luma block, the tree type may be the single tree, and when the chroma block has a different partitioning structure from that of the luma block, the tree type may be the dual tree. When the tree type is the single tree, first context information may be used when coding the transform index, and when the tree type is the dual tree, second context information may be used when coding the transform index.

[0210] Further, the first context information may be derived as a different value depending on the value of the MTS index. According to an example, the first context information may be derived as 1 when the MTS index is 0 and the tree

type is not a single tree type, and may be derived as 0 otherwise, that is, when the MTS index is not 0 or the tree type is the single tree type.

[0211] In decoding the transform index, when the MTS index is not received or decoded, the MTS index may be inferred as 0. In this case, since a condition that the MTS index is 0 is satisfied, the transform index may be derived as 1 when the tree type is not the single tree type, and may be derived as 0 when the tree type is the single tree type.

[0212] That is, the entropy decoder 310 receives the bin string binarized by truncated unary coding and decodes the syntax element of the transform index of the binary value based on the context information.

[0213] The value of the syntax element of the transform index applied to the target block among binary values that the syntax element of the transform index can have may be derived by this context information-based decoding (S930).

[0214] That is, which one of transform indexes of 0, 1, and 2 is applied to the current target block may be derived.

[0215] The inverse transformer 322 of the decoding apparatus 300 determines a transform set based on a mapping relationship according to the intra prediction mode applied to the target block (S940) and may perform an inverse RST, that is, an inverse non-separable transform, based on the transform set and the value of the syntax element of the transform index (S950).

[0216] As described above, a plurality of transform sets may be determined according to an intra prediction mode of a transform block to be transformed, and an RST may be performed based on any one of transform kernel matrices included in a transform set indicated by a transform index.

[0217] The following drawings are provided to describe specific examples of the present disclosure. Since the specific designations of devices or the designations of specific signals/messages/fields illustrated in the drawings are provided for illustration, technical features of the present disclosure are not limited to specific designations used in the following drawings.

[0218] FIG. 10 is a flowchart illustrating an operation of a video encoding apparatus according to an embodiment of the present disclosure.

[0219] Each operation illustrated in FIG. 10 may be performed by the encoding apparatus 200 illustrated in FIG. 2. Specifically, S1010 may be performed by the predictor 220 illustrated in FIG. 2, S1020 may be performed by the subtractor 231 illustrated in FIG. 2, S1030 and S1040 may be performed by the transformer 232 illustrated in FIG. 2, and S1050 may be performed by the quantizer 233 and the entropy encoder 240 illustrated in FIG. 2. Operations according to S1010 to S1050 are based on some of contents described in FIG. 4 to FIG. 7. Therefore, a description of specific details overlapping with those explained above with reference to FIG. 4 to FIG. 7 will be omitted or will be made briefly.

[0220] The encoding apparatus 200 according to an embodiment may derive prediction samples based on an intra prediction mode applied to a target block (S1010).

[0221] The encoding apparatus 200 according to an embodiment may derive residual samples for the target block (S1020).

[0222] The encoding apparatus 200 according to an embodiment may derive transform coefficients for the target block based on primary transform of the residual sample (S1030). The primary transform may be performed through a plurality of transform kernels, and the transform kernels may be selected based on the intra prediction mode.

[0223] The decoding apparatus 300 may perform a secondary transform or a non-separable transform, specifically an NSST, on the transform coefficients for the target block, in which case the NSST may be performed based on a reduced transform (RST) or without being based on the RST. When the NSST is performed based on the reduced transform, an operation according to S1040 may be performed.

[0224] The encoding apparatus 200 according to an embodiment may derive modified transform coefficients for the target block based on the RST of the transform coefficients (S1040). In an example, the RST may be performed based on a reduced transform matrix or a transform kernel matrix, and the reduced transform matrix may be a nonsquare matrix in which the number of rows is less than the number of columns.

[0225] In an embodiment, S1040 may include determining whether a condition for applying the RST is satisfied, generating and encoding the transform index based on the determination, selecting a transform kernel, and applying the RST to the residual samples based on the selected transform kernel matrix and/or a reduced factor when the condition for applying the RST is satisfied. In this case, the size of the reduced transform kernel matrix may be determined based on the reduced factor.

[0226] The encoding apparatus 200 according to an embodiment may derive quantized transform coefficients by performing quantization based on the modified transform coefficients for the target block and may encode information on the quantized transform coefficients (S1050).

[0227] Specifically, the encoding apparatus 200 may generate the information on the quantized transform coefficients and may encode the generated information on the quantized transform coefficients.

[0228] In an example, the information on the quantized transform coefficients may include at least one of information on whether the RST is applied, information on the reduced factor, information on a minimum transform size to which the RST is applied, and information on a maximum transform size to which the RST is applied.

[0229] Referring to S1040, it may be identified that the transform coefficients for the target block are derived based

on the RST of the residual samples. From the perspective of the size of the transform kernel matrix, since the size of a regular transform kernel matrix is $N \times N$ but the size of the reduced transform matrix is reduced to $R \times N$, it is possible to reduce memory usage in a case of performing the RST by an R/N ratio compared to that in a case of performing a regular transform. Further, using the reduced transform kernel matrix can reduce the number of multiplications ($R \times N$) by the R/N ratio, compared to the number of multiplications $N \times N$ in a case of using the regular transform kernel matrix. In addition, since only R transform coefficients are derived when the RST is applied, the total number of transform coefficients for the target block may be reduced from N to R , compared to that in a case where N transform coefficients are derived when a regular transform is applied, thus reducing the amount of data transmitted by the encoding apparatus 200 to the decoding apparatus 300. That is, according to S1040, the transform efficiency and coding efficiency of the encoding apparatus 320 may be increased through the RST.

[0230] FIG. 11 is a control flowchart illustrating a non-separable transform method including encoding of a transform index according to an embodiment of the present disclosure.

[0231] First, the encoding apparatus 200 may determine a transform set based on a mapping relationship according to an intra prediction mode applied to a target block (S 1100).

[0232] The encoding apparatus 200 may perform a primary transform based on an MTS before a non-separable transform based on the transform set, an MTS index indicating which MTS is used may be generated.

[0233] The transformer 232 may derive a transform coefficient by performing an RST, that is, a non-separable transform, based on any one of transform kernel matrices included in the transform set (S1110).

[0234] In this embodiment, the transform coefficient may be a modified transform coefficient resulting from a primary transform and then a secondary transform, and two transform kernel matrices may be included in each transform set.

[0235] When the RST is performed, information on the RST may be encoded by the entropy encoder 240.

[0236] The entropy encoder 240 may derive the value of a syntax element of a transform index indicating any one of the transform kernel matrices included in the transform set (S1120).

[0237] The syntax element of the transform index according to this embodiment may indicate whether an (inverse) RST is applied and any one of the transform kernel matrices included in the transform set. When the transform set includes two transform kernel matrices, the syntax element of the transform index may have three values.

[0238] According to an embodiment, the value of the syntax element of the transform index may be derived as 0 indicating that the (inverse) RST is not applied to a target block, as 1 indicating a first transform kernel matrix of the transform kernel matrices, or as 2 indicating a second transform kernel matrix of the transform kernel matrices.

[0239] The entropy encoder 240 may binarize the derived value of the syntax element of the transform index (S1130).

[0240] The entropy encoder 240 may binarize the three values of the syntax element of the transform index into 0, 10, and 11 according to truncated unary coding. That is, the value of the syntax element of 0 may be binarized into '0', the value of the syntax element of 1 may be binarized into '10', and the value of the syntax element of 2 may be binarized into '11', and the entropy encoder 240 may binarize the derived syntax element of the transform index into one of '0', '10, and '11'.

[0241] The entropy encoder 240 may derive context information, that is, a context model, on a bin string of the transform index (S1 140) according to the value of the MTS index and the tree type of the target block and may encode bins of the bin string of the syntax element based on the context information (S1150).

[0242] According to this embodiment, different pieces of context information may be applied to two bins of the transform index, respectively. That is, all of the two bins of the transform index may be encoded by a context method rather than by a bypass method, wherein a first bin of the bins of the syntax element of the transform index may be decoded based on first context information, and a second bin of the bins of the syntax element of the transform index may be decoded based on second context information.

[0243] According to another embodiment, the first bin of the two bins of the transform index may be encoded by the context method, and the second bin may be encoded by the bypass method.

[0244] The context information, particularly, the first context information on the first bin, may be derived as a different value depending on the value of the MTS index and the tree type of the target block.

[0245] For example, the tree type of the target block may be classified as a single tree (SINGLE_TREE) or a dual tree (DUAL_TREE) according to whether a chroma block corresponding to a luma block has a separate partitioning structure. When the chroma block has the same partitioning structure as that of the luma block, the tree type may be the single tree, and when the chroma block has a different partitioning structure from that of the luma block, the tree type may be the dual tree. When the tree type is the single tree, first context information may be used when coding the transform index, and when the tree type is the dual tree, second context information may be used when coding the transform index.

[0246] Further, the first context information may be derived as a different value depending on the value of the MTS index. According to an example, the first context information may be derived as 1 when the MTS index is 0 and the tree type is not a single tree type, and may be derived as 0 otherwise, that is, when the MTS index is not 0 or the tree type is the single tree type.

[0247] In decoding the transform index, when the MTS index is not generated or encoded, the MTS index may be

inferred as 0. In this case, since a condition that the MTS index is 0 is satisfied, the transform index may be derived as 1 when the tree type is not the single tree type, and may be derived as 0 when the tree type is the single tree type.

[0248] That is, the entropy encoder 240 derives the bin string binarized by truncated unary coding and encodes the syntax element of the transform index of the binary value based on the context information.

[0249] In the present disclosure, at least one of quantization/dequantization and/or transform/inverse transform may be omitted. When quantization/dequantization is omitted, a quantized transform coefficient may be referred to as a transform coefficient. When transform/inverse transform is omitted, the transform coefficient may be referred to as a coefficient or a residual coefficient, or may still be referred to as a transform coefficient for consistency of expression.

[0250] In addition, in the present disclosure, a quantized transform coefficient and a transform coefficient may be referred to as a transform coefficient and a scaled transform coefficient, respectively. In this case, residual information may include information on a transform coefficient(s), and the information on the transform coefficient(s) may be signaled through a residual coding syntax. Transform coefficients may be derived based on the residual information (or information on the transform coefficient(s)), and scaled transform coefficients may be derived through inverse transform (scaling) of the transform coefficients. Residual samples may be derived based on the inverse transform (transform) of the scaled transform coefficients. These details may also be applied/expressed in other parts of the present disclosure.

[0251] In the above-described embodiments, the methods are explained on the basis of flowcharts by means of a series of steps or blocks, but the present disclosure is not limited to the order of steps, and a certain step may be performed in order or step different from that described above, or concurrently with another step. Further, it may be understood by a person having ordinary skill in the art that the steps shown in a flowchart are not exclusive, and that another step may be incorporated or one or more steps of the flowchart may be removed without affecting the scope of the present disclosure.

[0252] The above-described methods according to the present disclosure may be implemented as a software form, and an encoding apparatus and/or decoding apparatus according to the disclosure may be included in a device for image processing, such as, a TV, a computer, a smartphone, a set-top box, a display device or the like.

[0253] When embodiments in the present disclosure are embodied by software, the above-described methods may be embodied as modules (processes, functions or the like) to perform the above-described functions. The modules may be stored in a memory and may be executed by a processor. The memory may be inside or outside the processor and may be connected to the processor in various well-known manners. The processor may include an application-specific integrated circuit (ASIC), other chipset, logic circuit, and/or a data processing device. The memory may include a read-only memory (ROM), a random access memory (RAM), a flash memory, a memory card, a storage medium, and/or other storage device. That is, embodiments described in the present disclosure may be embodied and performed on a processor, a microprocessor, a controller or a chip. For example, function units shown in each drawing may be embodied and performed on a computer, a processor, a microprocessor, a controller or a chip.

[0254] Further, the decoding apparatus and the encoding apparatus to which the present disclosure is applied, may be included in a multimedia broadcasting transceiver, a mobile communication terminal, a home cinema video device, a digital cinema video device, a surveillance camera, a video chat device, a real time communication device such as video communication, a mobile streaming device, a storage medium, a camcorder, a video on demand (VoD) service providing device, an over the top (OTT) video device, an Internet streaming service providing device, a three-dimensional (3D) video device, a video telephony video device, and a medical video device, and may be used to process a video signal or a data signal. For example, the over the top (OTT) video device may include a game console, a Blu-ray player, an Internet access TV, a Home theater system, a smartphone, a Tablet PC, a digital video recorder (DVR) and the like.

[0255] In addition, the processing method to which the present disclosure is applied, may be produced in the form of a program executed by a computer, and be stored in a computer-readable recording medium. Multimedia data having a data structure according to the present disclosure may also be stored in a computer-readable recording medium. The computer-readable recording medium includes all kinds of storage devices and distributed storage devices in which computer-readable data are stored. The computer-readable recording medium may include, for example, a Blu-ray Disc (BD), a universal serial bus (USB), a ROM, a PROM, an EPROM, an EEPROM, a RAM, a CD-ROM, a magnetic tape, a floppy disk, and an optical data storage device. Further, the computer-readable recording medium includes media embodied in the form of a carrier wave (for example, transmission over the Internet). In addition, a bitstream generated by the encoding method may be stored in a computer-readable recording medium or transmitted through a wired or wireless communication network. Additionally, the embodiments of the present disclosure may be embodied as a computer program product by program codes, and the program codes may be executed on a computer by the embodiments of the present disclosure. The program codes may be stored on a computer-readable carrier.

[0256] FIG. 12 illustrates the structure of a content streaming system to which the present disclosure is applied.

[0257] Further, the contents streaming system to which the present disclosure is applied may largely include an encoding server, a streaming server, a web server, a media storage, a user equipment, and a multimedia input device.

[0258] The encoding server functions to compress to digital data the contents input from the multimedia input devices, such as the smart phone, the camera, the camcorder and the like, to generate a bitstream, and to transmit it to the

streaming server. As another example, in a case where the multimedia input device, such as, the smart phone, the camera, the camcorder or the like, directly generates a bitstream, the encoding server may be omitted. The bitstream may be generated by an encoding method or a bitstream generation method to which the present disclosure is applied. And the streaming server may store the bitstream temporarily during a process to transmit or receive the bitstream.

5 **[0259]** The streaming server transmits multimedia data to the user equipment on the basis of a user's request through the web server, which functions as an instrument that informs a user of what service there is. When the user requests a service which the user wants, the web server transfers the request to the streaming server, and the streaming server transmits multimedia data to the user. In this regard, the contents streaming system may include a separate control server, and in this case, the control server functions to control commands/responses between respective equipments

10 **[0260]** The streaming server may receive contents from the media storage and/or the encoding server. For example, in a case the contents are received from the encoding server, the contents may be received in real time. In this case, the streaming server may store the bitstream for a predetermined period of time to provide the streaming service smoothly.

15 **[0261]** For example, the user equipment may include a mobile phone, a smart phone, a laptop computer, a digital broadcasting terminal, a personal digital assistant (PDA), a portable multimedia player (PMP), a navigation, a slate PC, a tablet PC, an ultrabook, a wearable device (e.g., a watch-type terminal (smart watch), a glass-type terminal (smart glass), a head mounted display (HMD)), a digital TV, a desktop computer, a digital signage or the like. Each of servers in the contents streaming system may be operated as a distributed server, and in this case, data received by each server may be processed in distributed manner.

20 **[0262]** Claims disclosed herein can be combined in a various way. For example, technical features of method claims of the present disclosure can be combined to be implemented or performed in an apparatus, and technical features of apparatus claims can be combined to be implemented or performed in a method. Further, technical features of method claims and apparatus claims can be combined to be implemented or performed in an apparatus, and technical features of method claims and apparatus claims can be combined to be implemented or performed in a method.

25 **[0263]** Further embodiments are described in the following numbered paragraphs:

1. An image decoding method performed by a decoding apparatus, the method comprising:

30 receiving a bitstream comprising residual information;
 deriving transform coefficients for a target block based on the residual information;
 deriving modified transform coefficients based on an inverse non-separable transform of the transform coefficients;
 deriving residual samples for the target block based on an inverse primary transform of the modified transform coefficients; and
 35 generating a reconstructed picture based on the residual samples for the target block,
 wherein the inverse non-separable transform is performed based on a transform index indicating a predetermined transform kernel matrix,
 wherein the inverse primary transform is performed based on a multiple transform selection (MTS) index indicating an MTS of a horizontal transform kernel and a vertical transform kernel, and
 40 wherein a syntax element bin string of the transform index is derived based on first context information, when a tree type of a partition structure of the target block is not a single tree type, and is derived based on second context information, when the tree type is the single tree type.

45 2. The image decoding method of paragraph 1, wherein the syntax element bin string of the transform index is derived based on the first context information when the MTS index has a value of 0 and the tree type is not the single tree type.

50 3. The image decoding method of paragraph 2, wherein, when the MTS index is not received, the MTS index is inferred to have a value of 0.

4. The image decoding method of paragraph 1, wherein the syntax element bin string of the transform index is derived based on the first context information when the MTS index is not received and the tree type is not the single tree type.

55 5. The image decoding method of paragraph 1, wherein the transform kernel matrix is comprised in a transform set determined based on a mapping relationship according to an intra prediction mode applied to the target block, and wherein the transform index indicates any one of whether the inverse non-separable transform is applied and the transform kernel matrix comprised in the transform set.

6. The image decoding method of paragraph 5, further comprising:

5 decoding bins of the syntax element bin string of the transform index based on the first context information or the second context information; and
6 deriving a value of a syntax element of the transform index.

7. The image decoding method of paragraph 6, wherein the value of the syntax element comprises any one of 0 indicating that the inverse non-separable transform is not applied to the target block, 1 indicating a first transform kernel matrix of the transform kernel matrix, and 2 indicating a second transform kernel matrix of the transform kernel matrix,

10 wherein the value of the syntax element is binarized into a truncated unary code, and
11 wherein the value of the syntax element of 0 is binarized into '0', the value of the syntax element of 1 is binarized into '10', and the value of the syntax element of 2 is binarized into '11'.

8. An image encoding method performed by an image encoding apparatus, the method comprising:

15 deriving prediction samples for a target block;
16 deriving residual samples for the target block based on the prediction samples;
17 deriving transform coefficients for the target block from the residual samples based on a multiple transform selection (MTS) of a horizontal transform kernel and a vertical transform kernel;
18 deriving modified transform coefficients from the transform coefficients based on a predetermined transform kernel matrix for a non-separable transform; and
19 encoding an MTS index indicating the MTS or a transform index indicating the transform kernel matrix,
20 wherein a syntax element bin string of the transform index is derived based on first context information, when a tree type of a partition structure of the target block is not a single tree type, and is derived based on second context information, when the tree type is the single tree type.

25 9. The image encoding method of paragraph 8, wherein the syntax element bin string of the transform index is derived based on the first context information when the MTS index has a value of 0 and the tree type is not the single tree type.

30 10. The image encoding method of paragraph 9, wherein, when the MTS index is not encoded, the MTS index is inferred to have a value of 0.

35 11. The image encoding method of paragraph 8, wherein the syntax element bin string of the transform index is derived based on the first context information when the MTS index is not encoded and the tree type is not the single tree type.

40 12. The image encoding method of paragraph 8, wherein the transform kernel matrix is comprised in a transform set determined based on a mapping relationship according to an intra prediction mode applied to the target block, and wherein the transform index indicates any one of whether the inverse non-separable transform is applied and the transform kernel matrix comprised in the transform set.

45 13. The image encoding method of paragraph 12, further comprising:

46 deriving a value of a syntax element of the transform index; and
47 encoding bins of the syntax element bin string of the transform index based on the first context information or the second context information.

50 14. The image encoding method of paragraph 13, wherein the value of the syntax element comprises any one of 0 indicating that the inverse non-separable transform is not applied to the target block, 1 indicating a first transform kernel matrix of the transform kernel matrix, and 2 indicating a second transform kernel matrix of the transform kernel matrix,

55 wherein the value of the syntax element is binarized into a truncated unary code, and
56 wherein the value of the syntax element of 0 is binarized into '0', the value of the syntax element of 1 is binarized into '10', and the value of the syntax element of 2 is binarized into '11'.

15. A computer-readable digital storage medium that stores indication information to cause an image decoding method to be performed, the image decoding method comprising:

5 receiving a bitstream comprising residual information;
 deriving transform coefficients for a target block based on the residual information;
 deriving modified transform coefficients based on an inverse non-separable transform of the transform coefficients;
 deriving residual samples for the target block based on an inverse primary transform of the modified transform coefficients; and
 10 generating a reconstructed picture based on the residual samples for the target block,
 wherein the inverse non-separable transform is performed based on a transform index indicating a predetermined transform kernel matrix,
 wherein the inverse primary transform is performed based on a multiple transform selection (MTS) index indicating an MTS of a horizontal transform kernel and a vertical transform kernel, and
 15 wherein a syntax element bin string of the transform index is derived based on first context information, when a tree type of a partition structure of the target block is not a single tree type, and is derived based on second context information, when the tree type is the single tree type.

20 Claims

1. An image decoding method performed by a decoding apparatus, comprising:

25 receiving (S810) a bitstream comprising residual information;
 deriving (S810) quantized transform coefficients for a target block based on the residual information;
 deriving (S820) transform coefficients for the target block by dequantizing the quantized transform coefficients;
 deriving (S830) modified transform coefficients based on an inverse non-separable transform of the transform coefficients;
 deriving (S840) residual samples for the target block based on an inverse primary transform of the modified transform coefficients; and
 30 generating (S850) a reconstructed picture based on the residual samples for the target block,
 wherein the inverse non-separable transform is performed based on a transform index indicating one of transform kernel matrices included in a transform set,
 wherein the inverse primary transform is performed based on a multiple transform selection, MTS, index indicating an MTS of a horizontal transform kernel and a vertical transform kernel,
 35 wherein the MTS index is not received from the bitstream and is inferred equal to 0,
 wherein the transform index indicating the one of the transform kernel matrices included in the transform set is context-decoded based on a context increment,
 wherein based on a tree type of a partition structure of the target block being not a single tree type, a context increment on a first bin among a bin string for the transform index is derived as a first context increment equal to 1, and
 40 wherein based on the tree type being the single tree type, the context increment on the first bin is derived as a second context increment equal to 0.

45 2. The image decoding method of claim 1, further comprising:

decoding (S920) bins of the bin string of the transform index based on the first context increment or the second context increment; and
 deriving (S930) a value of the transform index.

50 3. The image decoding method of claim 2, wherein the value of the transform index comprises any one of 0 indicating that the inverse non-separable transform is not applied to the target block, 1 indicating a first transform kernel matrix of the transform kernel matrices, and 2 indicating a second transform kernel matrix of the transform kernel matrices.

55 4. The image decoding method of claim 3, wherein the value of the transform index is binarized into a truncated unary code, and
 wherein the value of the transform index equal to 0 is binarized into '0', the value of the transform equal to 1 is binarized into '10', and the value of the transform index equal to 2 is binarized into '11'.

5. An image encoding method performed by an image encoding apparatus, comprising:

deriving (S1020) residual samples for a target block;
 deriving (S1030) transform coefficients for the target block from the residual samples based on a multiple
 5 transform selection, MTS, of a horizontal transform kernel and a vertical transform kernel;
 deriving (S 1040) modified transform coefficients from the transform coefficients based on one of transform
 kernel matrices included in a transform set for a non-separable transform;
 deriving (S 1050) quantized transform coefficients by quantizing the modified transform coefficients; and
 10 encoding (S 1040, S 1050) a transform index indicating the one of the transform kernel matrices included in the
 transform set and residual information related to the quantized transform coefficients,
 wherein an MTS index indicating the MTS is not encoded and is inferred equal to 0,
 wherein the transform index indicating the one of the transform kernel matrices included in the transform set is
 context-encoded based on a context increment,
 15 wherein based on a tree type of a partition structure of the target block being not a single tree type, a context
 increment on a first bin among a bin string for the transform index is derived as a first context increment equal
 to 1, and
 wherein based on the tree type being the single tree type, the context increment on the first bin is derived as a
 second context increment equal to 0.

20 6. The image encoding method of claim 5, further comprising:

deriving (S 1120) a value of the transform index; and
 encoding (S 1 150) bins of the bin string of the transform index based on the first context increment or the
 25 second context increment.

7. The image encoding method of claim 6, wherein the value of the transform index comprises any one of 0 indicating
 that the inverse non-separable transform is not applied to the target block, 1 indicating a first transform kernel matrix
 of the transform kernel matrices, and 2 indicating a second transform kernel matrix of the transform kernel matrices.

30 8. The image encoding method of claim 7, wherein the value of the transform index is binarized into a truncated unary
 code, and
 wherein the value of the transform index equal to 0 is binarized into '0', the value of the transform index equal to 1
 is binarized into '10', and the value of the transform index equal to 2 is binarized into '11'.

35 9. A non-transitory computer-readable digital storage medium storing a bitstream generated by a method, the method
 comprising:

deriving (S 1020) residual samples for a target block;
 deriving (S 1030) transform coefficients for the target block from the residual samples based on a multiple
 40 transform selection (MTS) of a horizontal transform kernel and a vertical transform kernel;
 deriving (S 1040) modified transform coefficients from the transform coefficients based on one of transform
 kernel matrices included in a transform set for a non-separable transform;
 deriving (S 1050) quantized transform coefficients by quantizing the modified transform coefficients; and
 45 encoding (S 1040, S 1050) a transform index indicating the one of the transform kernel matrices included in the
 transform set and residual information related to the quantized transform coefficients to generate the bitstream,
 wherein an MTS index indicating the MTS is not encoded and is inferred equal to 0,
 wherein the transform index indicating the one of the transform kernel matrices included in the transform set is
 context-encoded based on a context increment,
 50 wherein based on a tree type of a partition structure of the target block being not a single tree type, a context
 increment on a first bin among a bin string for the transform index is derived as a first context increment equal
 to 1, and
 wherein based on the tree type being the single tree type, the context increment on the first bin is derived as a
 second context increment equal to 0.

55 10. A method of transmitting a bitstream, comprising:

obtaining the bitstream, wherein the bitstream is generated by deriving (S 1020) residual samples for a target
 block, deriving (S 1030) transform coefficients for the target block from the residual samples based on a multiple

EP 4 415 358 A2

transform selection (MTS) of a horizontal transform kernel and a vertical transform kernel, deriving (S1040) modified transform coefficients from the transform coefficients based on one of transform kernel matrices included in a transform set for a non-separable transform, deriving (S 1050) quantized transform coefficients by quantizing the modified transform coefficients, and encoding (S 1040, S 1050) a transform index indicating the one of the transform kernel matrices included in the transform set and residual information related to the quantized transform coefficients; and
transmitting the bitstream,
wherein an MTS index indicating the MTS is not encoded and is inferred equal to 0,
wherein the transform index indicating the one of the transform kernel matrices included in the transform set is context-encoded based on a context increment,
wherein based on a tree type of a partition structure of the target block being not a single tree type, a context increment on a first bin among a bin string for the transform index is derived as a first context increment equal to 1, and
wherein based on the tree type being the single tree type, the context increment on the first bin is derived as a second context increment equal to 0.

5

10

15

20

25

30

35

40

45

50

55

FIG. 1

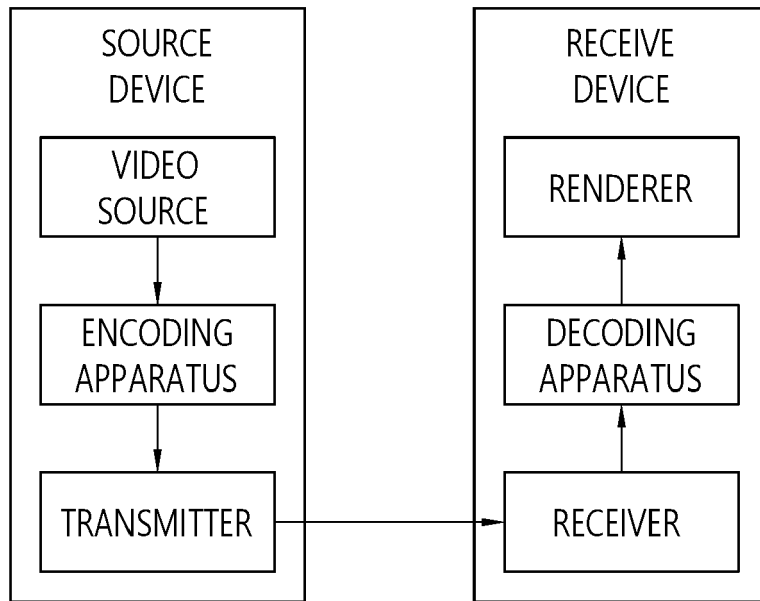

FIG. 2

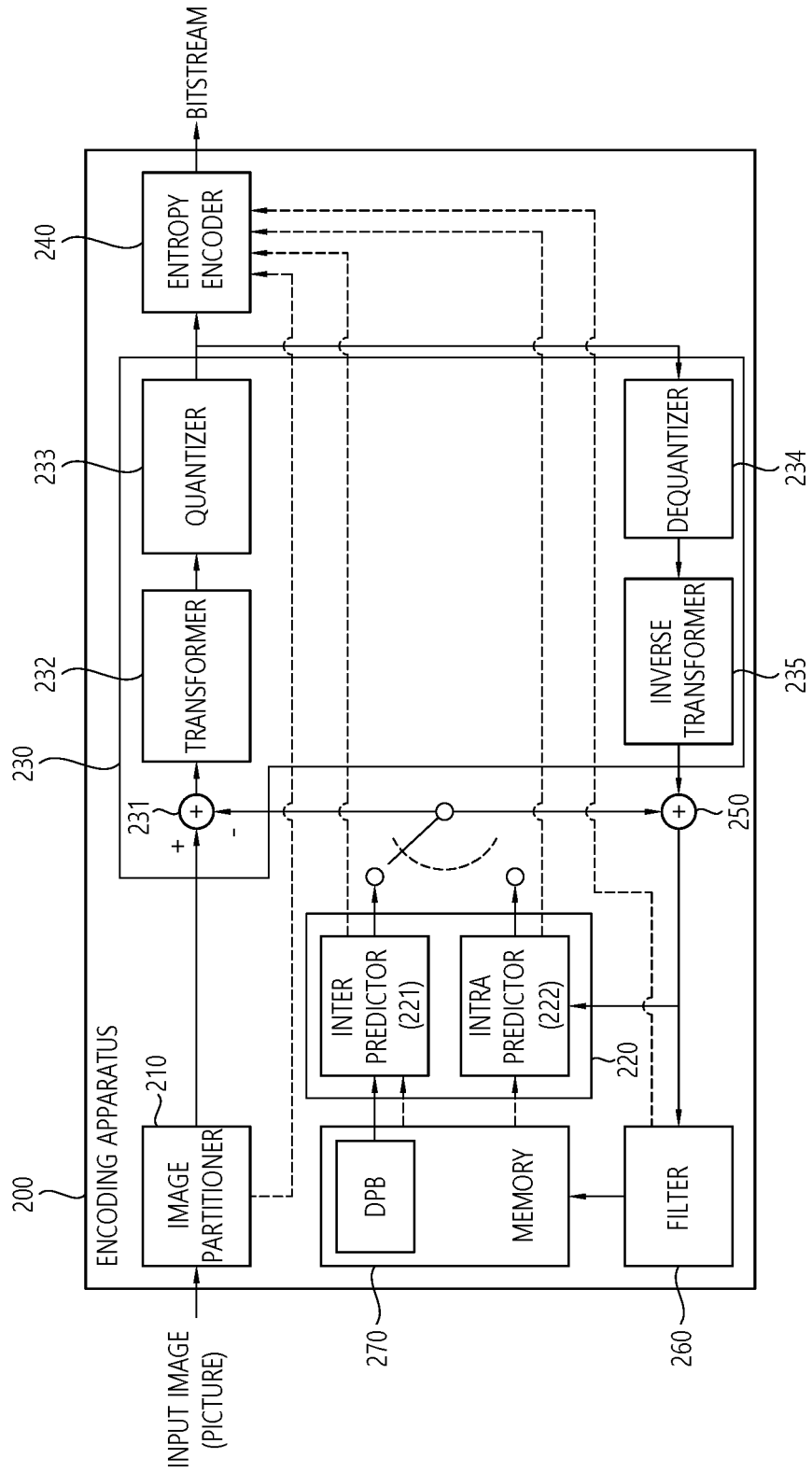

FIG. 3

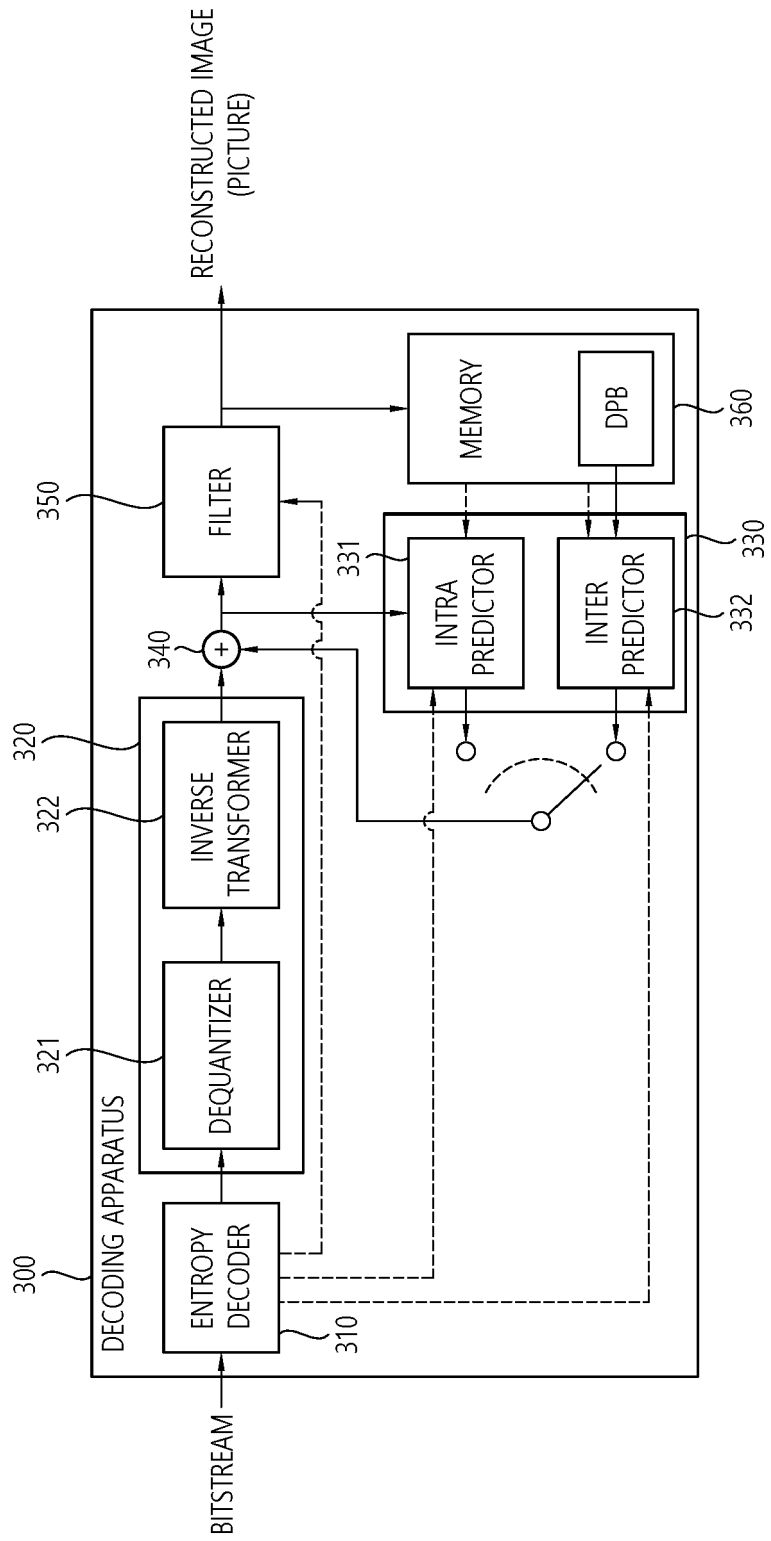

FIG. 4

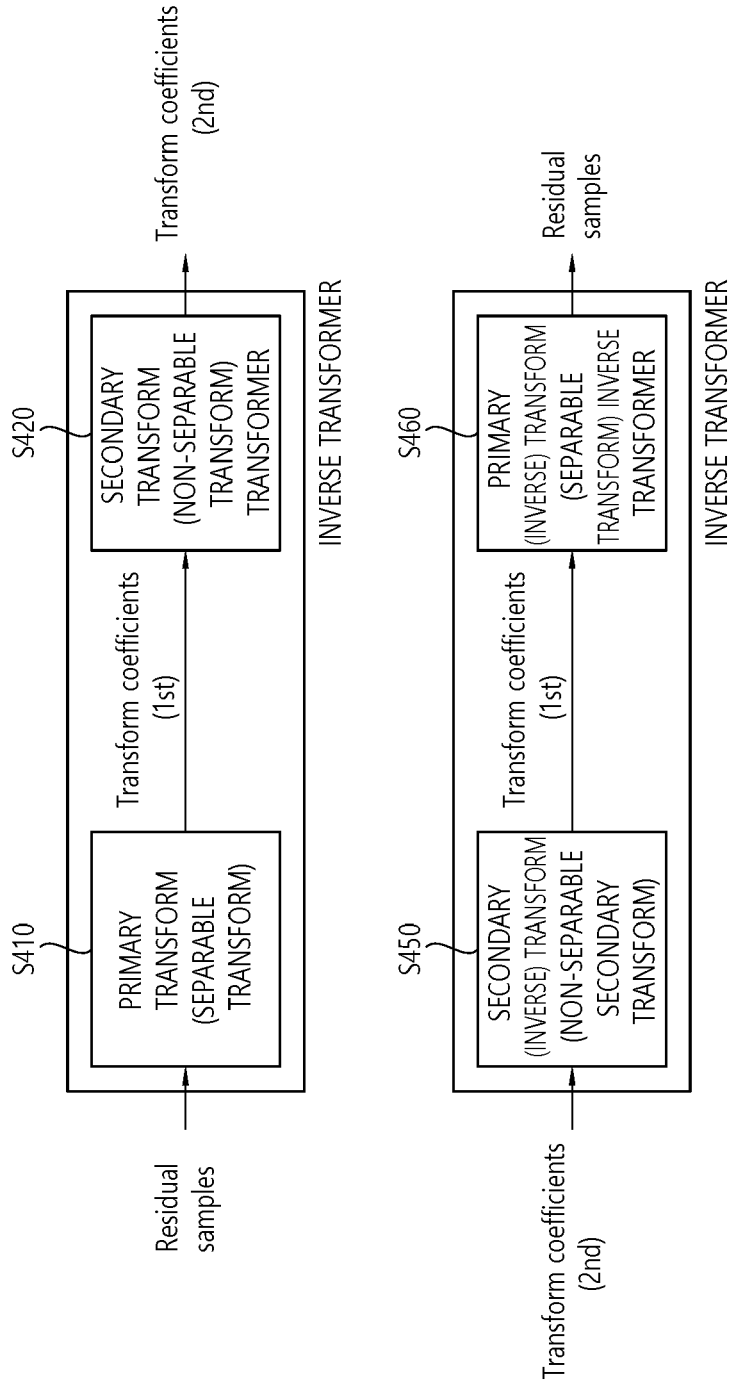

FIG. 5

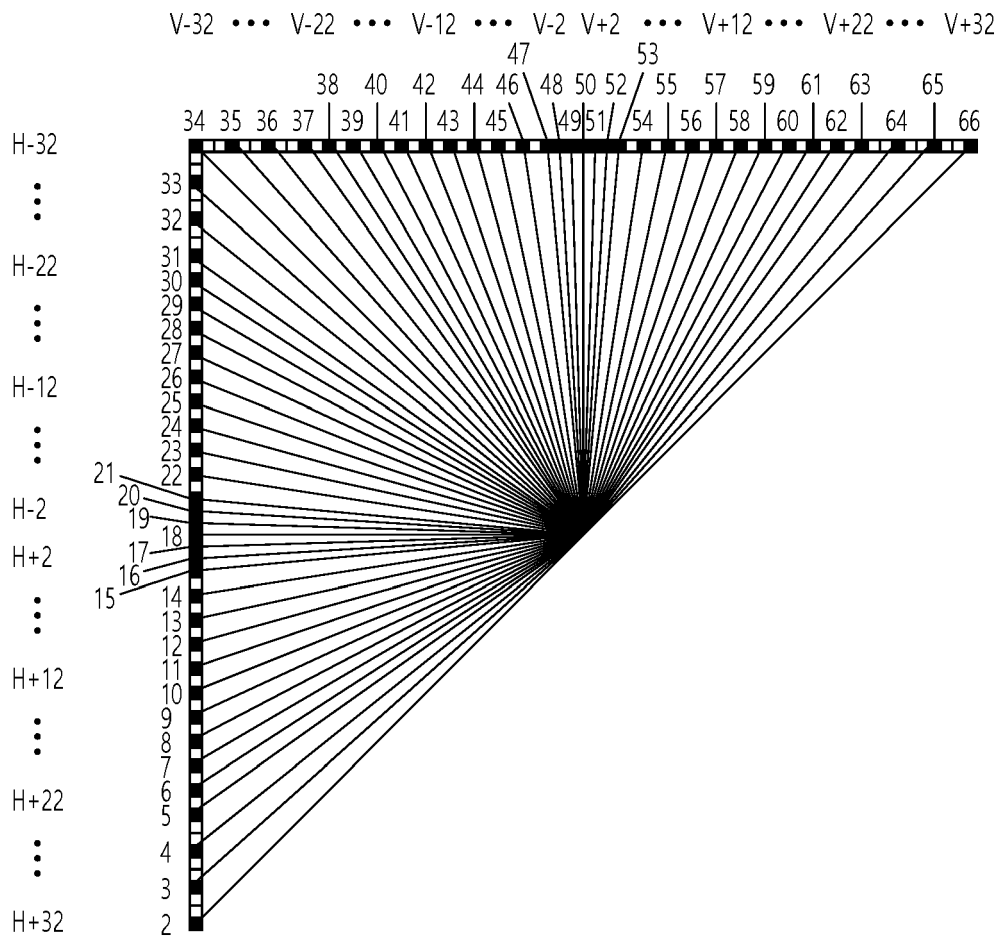

FIG. 6

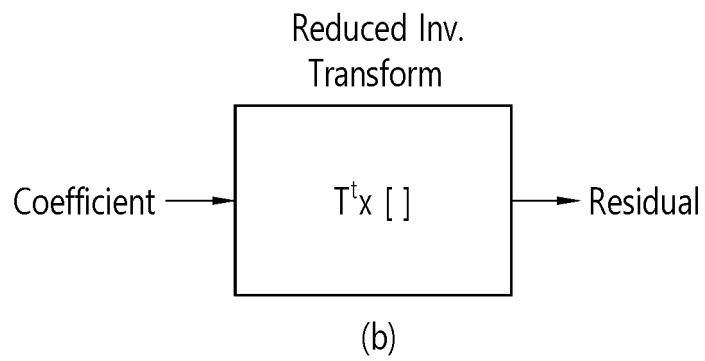
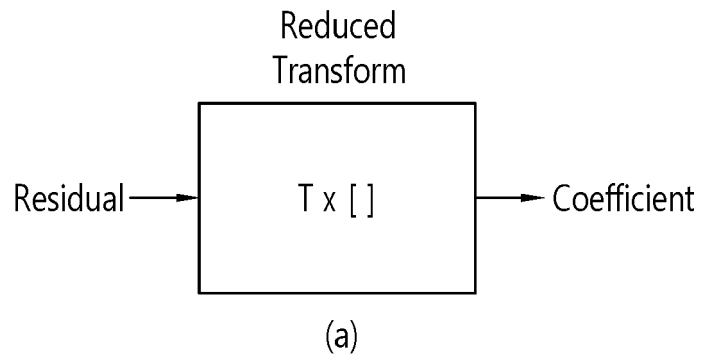

FIG. 7

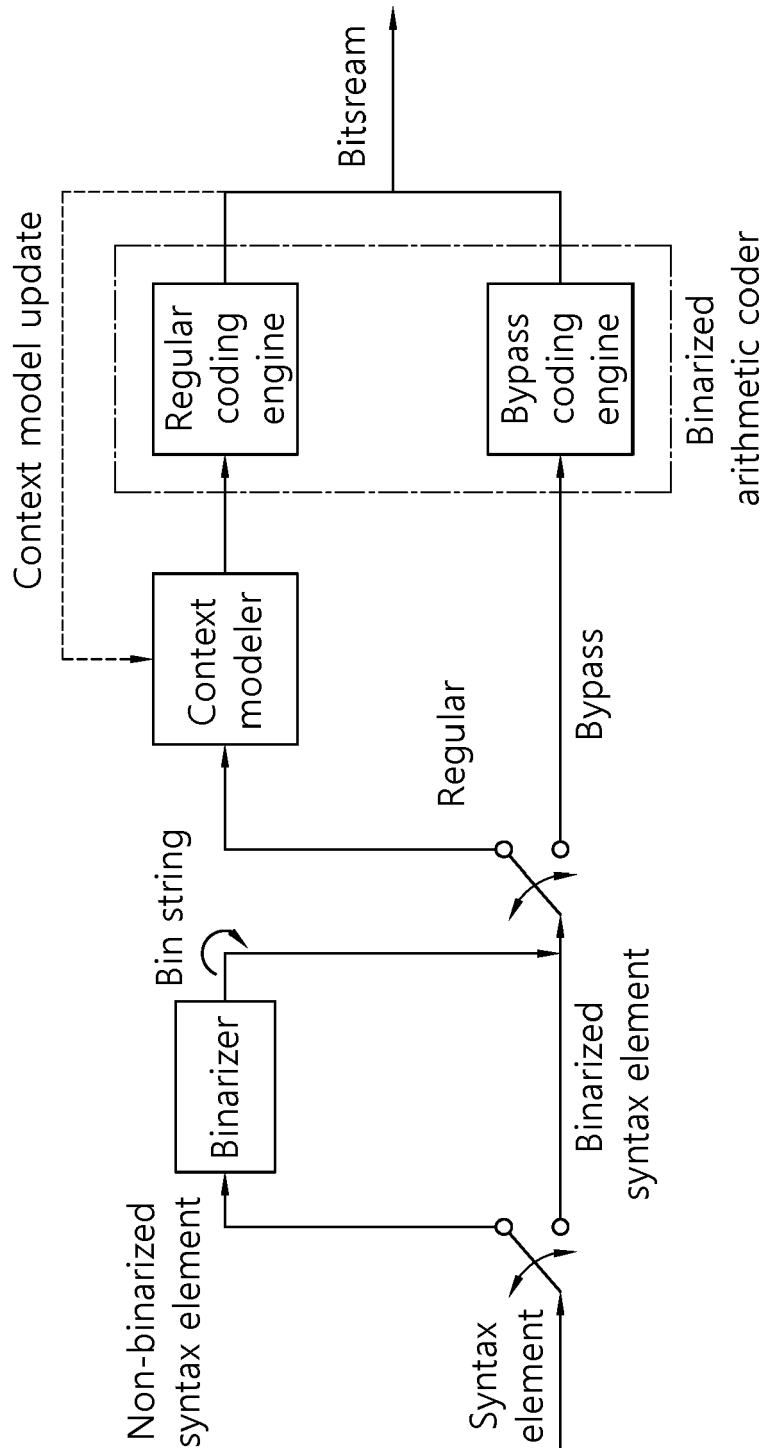

FIG. 8

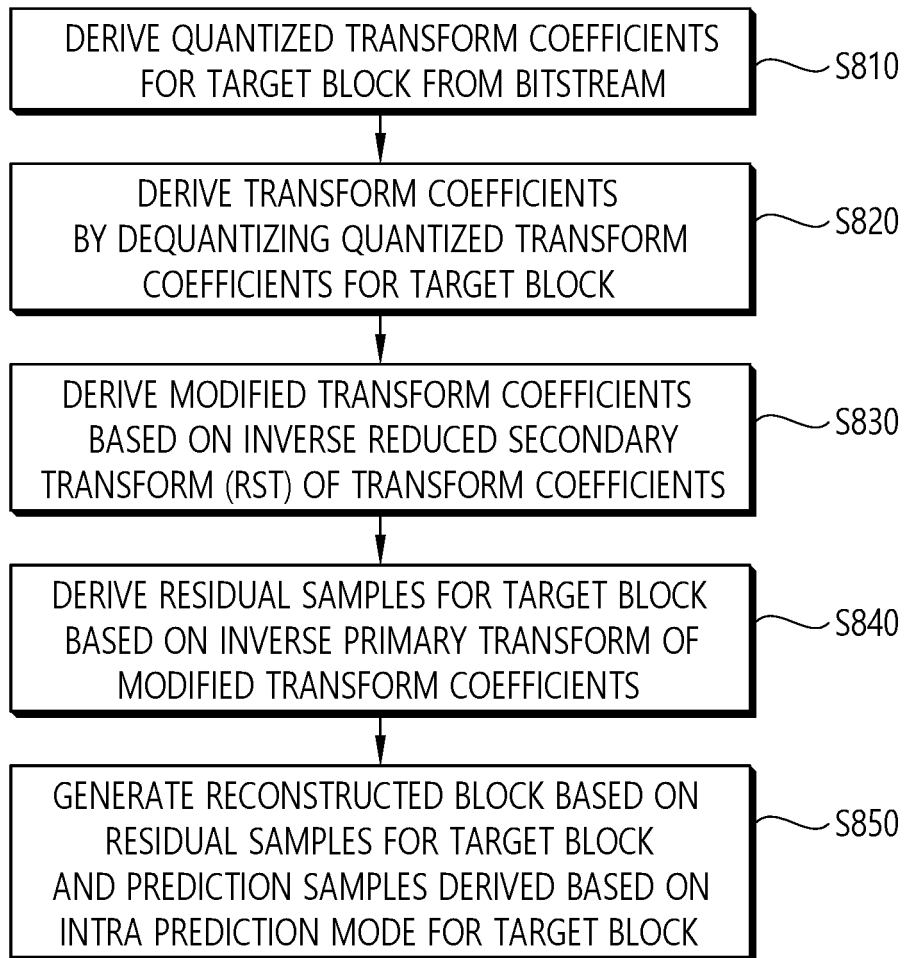

FIG. 9

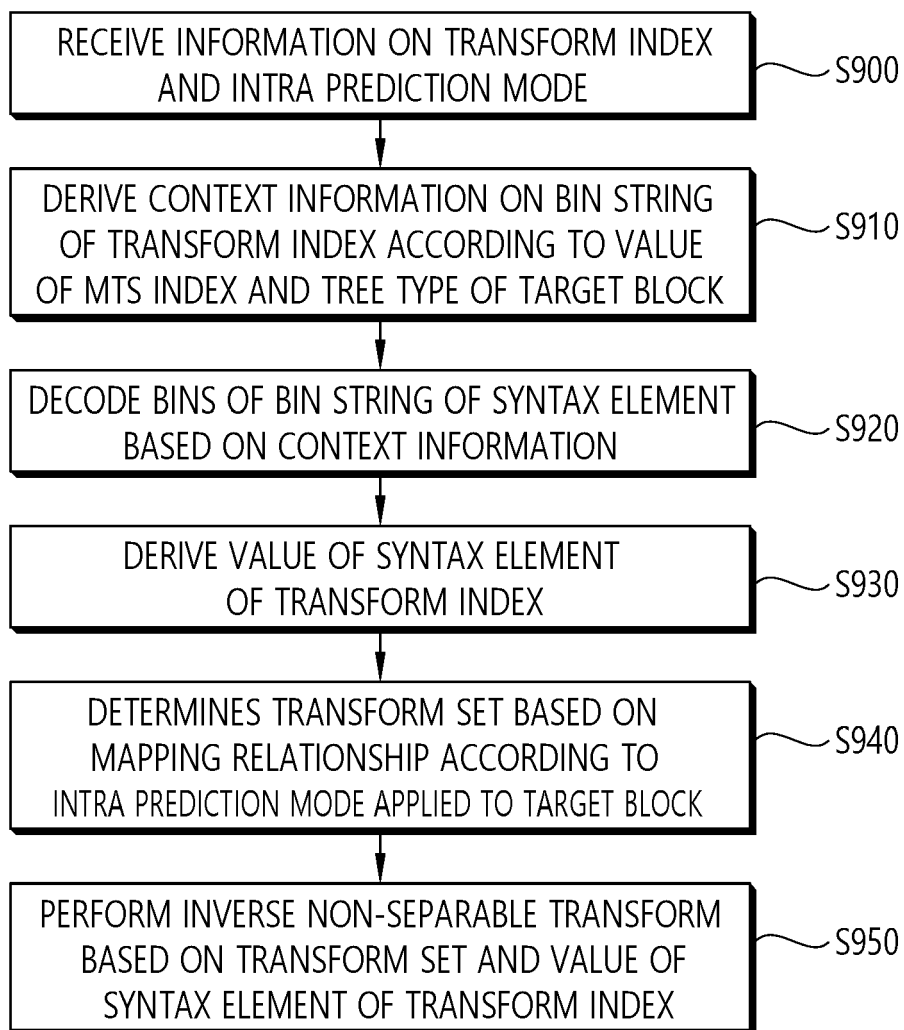

FIG. 10

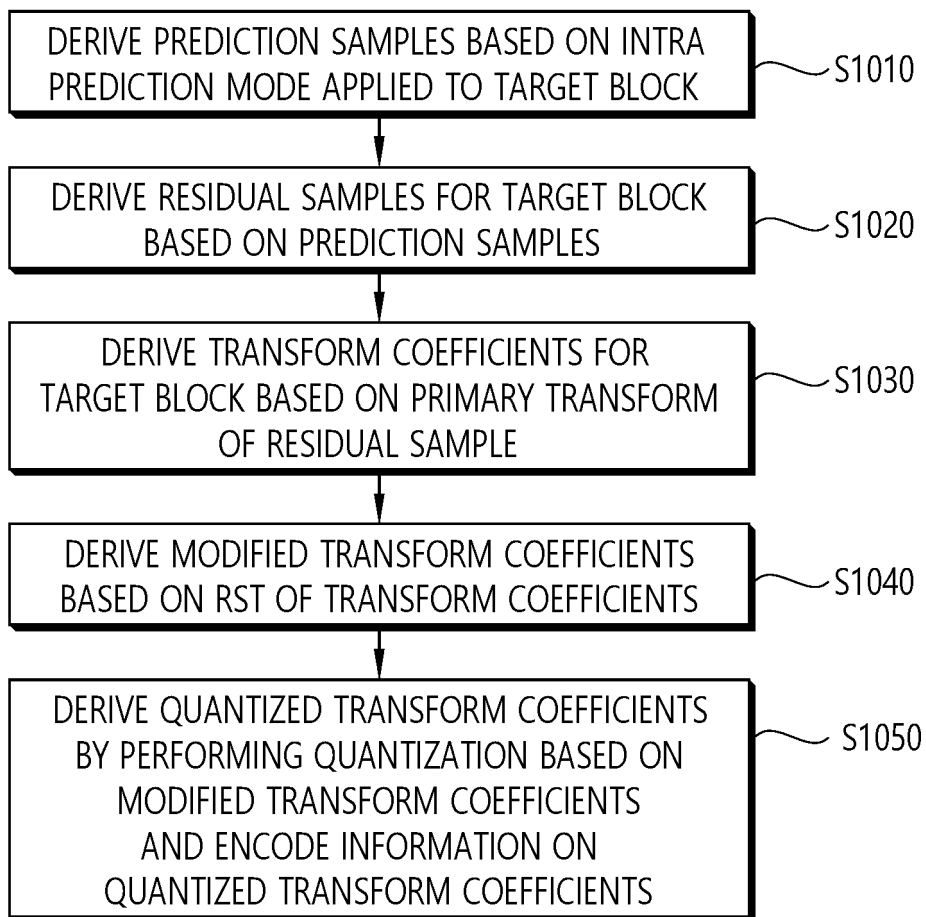

FIG. 11

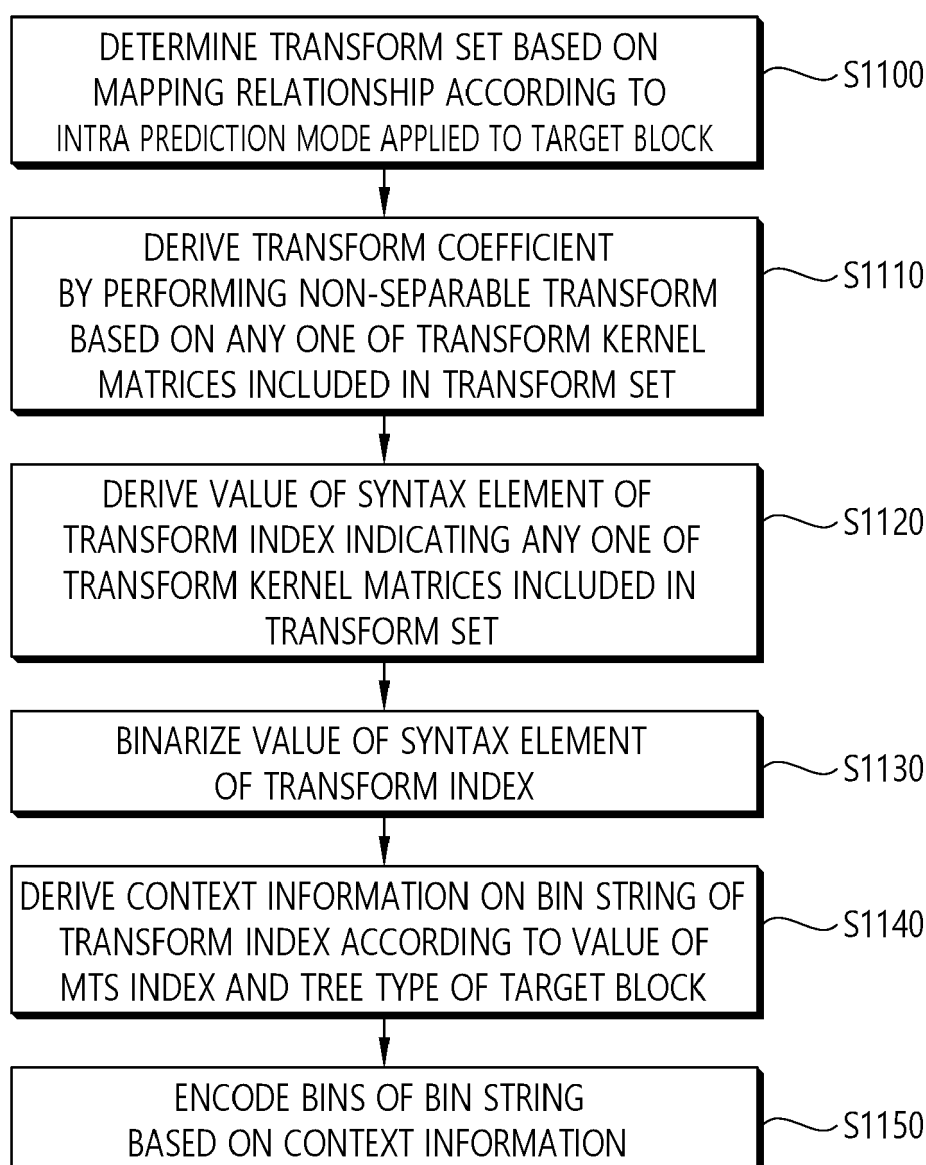

FIG. 12

