

(19) World Intellectual Property
Organization
International Bureau



(43) International Publication Date
29 December 2005 (29.12.2005)

PCT

(10) International Publication Number
WO 2005/124327 A1

(51) International Patent Classification⁷: G01N 27/12, 33/00

(21) International Application Number: PCT/EP2005/006349

(22) International Filing Date: 14 June 2005 (14.06.2005)

(25) Filing Language: English

(26) Publication Language: English

(30) Priority Data: TO2004A000411 21 June 2004 (21.06.2004) IT

(71) Applicant (for all designated States except US): TELECOM ITALIA S.P.A. [IT/IT]; Piazza Degli Affari, 2, I-20123 Milano (IT).

(72) Inventor; and

(75) Inventor/Applicant (for US only): CERUTTI, Walter [IT/IT]; Olivetti I-Jet S.p.A., Localita Le Vieux, I-11020 Arnad (AO) (IT).

(74) Agents: GIANNESI, Pier, Giovanni et al.; Pirelli & C. S.p.A., Viale Sarca, 222, I-20126 Milano (IT).

(81) Designated States (unless otherwise indicated, for every kind of national protection available): AE, AG, AL, AM, AT, AU, AZ, BA, BB, BG, BR, BW, BY, BZ, CA, CH, CN, CO, CR, CU, CZ, DE, DK, DM, DZ, EC, EE, EG, ES, FI, GB, GD, GE, GH, GM, HR, HU, ID, IL, IN, IS, JP, KE, KG, KM, KP, KR, KZ, LC, LK, LR, LS, LT, LU, LV, MA, MD, MG, MK, MN, MW, MX, MZ, NA, NG, NI, NO, NZ, OM, PG, PH, PL, PT, RO, RU, SC, SD, SE, SG, SK, SL, SM, SY, TJ, TM, TN, TR, TT, TZ, UA, UG, US, UZ, VC, VN, YU, ZA, ZM, ZW.

(84) Designated States (unless otherwise indicated, for every kind of regional protection available): ARIPO (BW, GH, GM, KE, LS, MW, MZ, NA, SD, SL, SZ, TZ, UG, ZM, ZW), Eurasian (AM, AZ, BY, KG, KZ, MD, RU, TJ, TM), European (AT, BE, BG, CH, CY, CZ, DE, DK, EE, ES, FI, FR, GB, GR, HU, IE, IS, IT, LT, LU, MC, NL, PL, PT, RO, SE, SI, SK, TR), OAPI (BF, BJ, CF, CG, CI, CM, GA, GN, GQ, GW, ML, MR, NE, SN, TD, TG).

Declaration under Rule 4.17:

— as to the applicant's entitlement to claim the priority of the earlier application (Rule 4.17(iii)) for all designations

[Continued on next page]

(54) Title: PHYSICAL QUANTITY, PARTICULARLY HUMIDITY DETECTION DEVICE, AND RELATED DETECTING METHOD

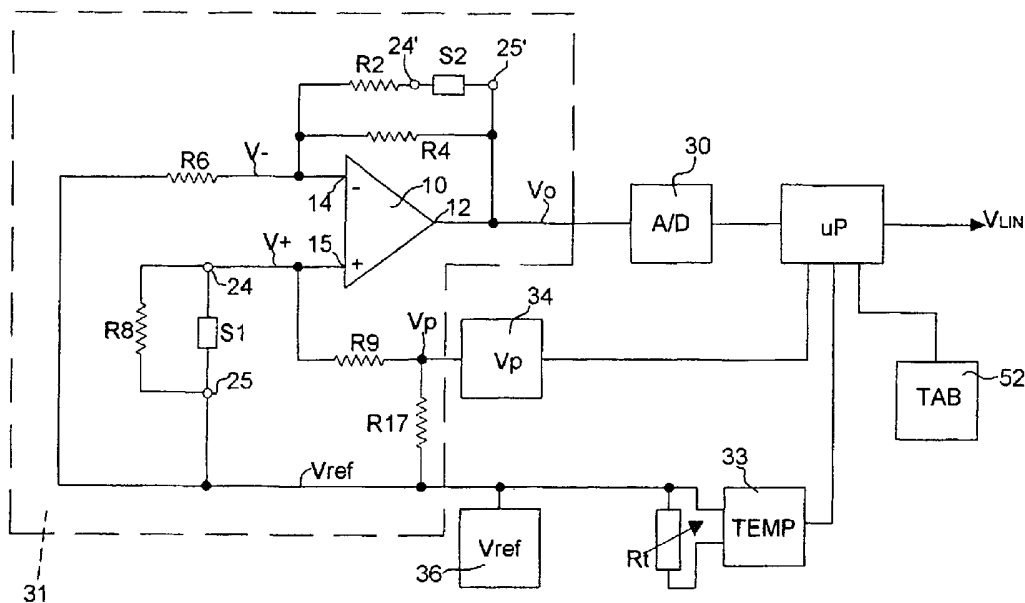

(57) Abstract: A pair of identical humidity sensors (S1) and (S2) are in the same environment, so that they identically react to humidity effects; a sensing circuit includes an operational amplifier (10), its input (15) receiving from the first sensor (Si) a signal changing with humidity according to a logarithmic law, while the second sensor (S2), inserted in the amplifier feedback, reacts to humidity changes in the same way as the first sensor (Si) and consistently modifies the gain. The output signal (Vo) is compensated, and has a substantially linear progression with humidity.

WO 2005/124327 A1



Published:

— *with international search report*

For two-letter codes and other abbreviations, refer to the "Guidance Notes on Codes and Abbreviations" appearing at the beginning of each regular issue of the PCT Gazette.

**PHYSICAL QUANTITY, PARTICULARLY HUMIDITY DETECTION DEVICE,
AND RELATED DETECTING METHOD**

* * * * *

Technological field of the invention

5 The present invention relates to a physical quantity, particularly humidity detection device, and to the related method of detection, and more in particular it relates to a sensing circuit suitable to detect and process the data provided by a physical quantity, particularly
10 humidity sensor, detected in open environments, or in inaccessible places.

Brief description of the state of the art

Physical quantity, particularly humidity detection devices are well known in the current art, which are based
15 on different detection techniques and different constructions of the sensors used; in particular, among the constructions used in the art in order to make humidity sensors, the most recurrent one consists of using a chemically inert support, on which generally a double array
20 of conductors are deposited, interlaced with and insulated from one another, covered by a layer of a material sensitive to humidity, having electric characteristics, such as resistivity or dielectric constant, depending on the humidity in the environment where the sensor is
25 plunged.

Humidity sensors known in the art use, as a material sensitive to humidity, electrically conductive materials, which have a resistivity changing with humidity,

as described in U.S. patent n° 6229318, or dielectric materials whose dielectric constant changes with humidity, as described in U.S. patent 3582728.

In U.S. patents n° 4642601 and n° 4793175, among 5 materials of a resistive type, conductive hydrophilic polymers, sintered ceramic powders, resins, or properly treated metal salt-based compounds are mentioned.

However, the applicant has observed that the resistive sensors described in the above mentioned 10 documents have a logarithmic type of response, difficult to be represented and very inexact below 20% of relative humidity (RH), which requires sophisticate electronic apparatus for the subsequent processing. On the other hand, resistive type sensors offer a very good interchangeability 15 and require low cost manufacturing.

Materials of a capacitive type, comprised of ceramic compounds or dielectric polymers, such as for example cellulose-acetate butyrate (CAB) or polymethyl methacrylate, are described in U.S. patents n° 3582728 and 20 n° 4442422.

The applicant has observed that the capacitive-type sensors described in the preceding documents require a very expensive processing compared with resistive sensors, but on the other hand they present a substantially linear 25 response relative to humidity, require a simple electronic and work in a wide range of humidity.

Sensors based on resistive type materials described in the preceding documents can be supplied with direct

voltage, or with unipolar pulses, while sensors using the materials of a capacitive type mentioned above must necessarily be supplied by an alternating voltage, with a waveform chosen in relation to the characteristics of the humidity sensitive material, and to the type of response required from the sensor.

U.S. patent n° 5040090 mentions humidity sensors which use, as humidity sensitive materials, electrolyte polymeric compounds, made of ionic conduction resins, which present the electrolytic dissociation phenomenon in the presence of water, as for example, crossed-link copolymers of styrene sulphonate and polyvinyl chloride, copolymers of ionic or non-ionic monomers, poly-4-vinylpyridine reticulated with dibromobutane; U.S. patent n° 5546802 also mentions cross-linked conductive polymers having ethylenically unsaturated groups.

In U.S. patent n° 6,229,318 a humidity measuring device of a resistive type is described, made of a humidity sensor and a temperature sensor having the same temperature characteristics as the humidity sensor, but protected by a non-hygroscopic layer; in both sensors, the electrodes are deposited on a support comprised of a carbonaceous porous material, obtained by sintering and carbonizing blends of wood and paper residuals, with thermosetting resins added.

The two sensors are connected in series in a sensing circuit, and are supplied by a current I_s ; the voltage fall at the ends of each of the two sensors is sent to a subtractive differential amplifier, properly fed back

in such a way as to generate an output equal to zero volts for null RH and a maximum output for RH equal to 100%.

The applicant observes that as the amplifier introduces only a limited compensation of the non-linearity of the humidity sensor response, this circuit does not
5 totally solve the problem.

Another relative humidity detection device is described in U.S. patent n° 5,406,137; a sensing circuit uses a capacitive sensor, which capacity changes with
10 humidity; a "one-shot" circuit generates a pulse, the duration of which is determined by the sensor capacity; this circuit is synchronized on the falling edge of each pulse generated by a multivibrator; the pulses produced by the "one-shot" circuit are integrated by an R - C net to
15 produce a voltage proportional to the average duration of the pulses; such voltage is sent to a correction circuit, which output feeds back a multivibrator supply circuit to modify the duration and the interval of the pulses generated by the multivibrator; moreover the supply voltage
20 of the multivibrator and the "one-shot" circuit can be manually changed with a potentiometer, in such a way as to correct the non-linearity of the sensor response to humidity changes and to maintain the calibration at an optimal value.

25 The applicant observes that this circuit is constructionally very complex and of not much reliable use due to the continuous manual adjustments required to maintain in time the measurement precision required.

Within the present invention the applicant has perceived the problem of creating a humidity detection device capable of providing a substantially linear relation between humidity values and the non-linear response of the humidity sensor, and with a constant precision on the whole
5 range of measurement.

Within the present invention the applicant has perceived the problem of creating a humidity detection device capable of providing a humidity measurement
10 independent of temperature changes in the environment wherein the sensor is placed.

The applicant has perceived that the signal of a physical quantity detection device could have been made with a linear progression and independent of temperature by
15 means of using two sensors exposed to the same quantity, by using the signal of one of said sensors to modulate the gain of an amplifier of a signal of the other sensor.

In a first aspect, the present invention relates to a physical quantity detection device, including a sensor,
20 sensitive to said physical quantity and exposed thereto, and an amplifier, connected to said sensor output by a first input and having a second reference input, which comprises a second sensor, sensitive to said physical quantity and exposed thereto, connected to the amplifier
25 output and further connected to said reference input.

Preferably, said amplifier is an operational amplifier, wherein said first sensor is connected between a noninverting input and a reference voltage source, and

wherein said second sensor is inserted in the feedback line of said amplifier, being connected between said output and an inverting input of said amplifier.

Preferably, the curves representing the resistance
5 change of said first sensor and of said second sensor as a function of the physical quantity to be detected, have the same progression; particularly, their first and second derivatives are of the same sign.

In a preferred embodiment, said particular physical
10 quantity is the relative humidity present in the environment where said sensors are arranged.

In a preferred embodiment, said detection means
further comprise a resistance connected in parallel to said first sensor, in order to limit the resistance applied to
15 said first input, when said first sensor has a very high resistance at low humidity values. Moreover, said detection means include, conveniently, a second resistance connected in series to said second sensor, and a third resistance connected in parallel to both said second sensor and said
20 second resistance, in order to limit the minimum and maximum gain of said amplifier, respectively, when said second sensor is plunged in an environment with very high or very low humidity, respectively.

Preferably, said first sensor is connected between
25 a driving signal generator and said reference voltage generator. Said driving signals are preferably comprised of a direct voltage, referred to said reference voltage, and they actuate said first sensor in order to generate said

response signal, variable with humidity changes.

Preferably, said driving signals are comprised of at least two homopolar rectangular waves, having a predetermined duration; alternatively, said driving signals
5 are comprised of at least two rectangular waves, of opposed polarity, and having a null average value, coinciding with said reference voltage.

In a preferred embodiment, each of said sensors comprises a double array of electric conductors separated
10 from one another, deposited over an insulating support and respectively connected to said pair of electric terminals, said electric conductors being covered with a layer of a material sensitive to one of said particular physical quantities, particularly humidity, and with a permeable
15 layer, laid upon said sensitive layer.

In a second aspect, the present invention refers to a method for detecting physical quantities which provides the following steps:

- a) driving a first sensor of a physical quantity
20 with a predetermined driving signal in order to obtain a first output signal, function of the physical quantity;
- b) amplifying the first output signal and obtaining an amplified signal V_0 in response to
25 said first output signal;
- c) driving a second sensor, arranged in the same environment as the first sensor, with a driving signal comprised of the amplified signal and

obtaining a second output signal;

d) continuously adjusting the amplification gain of the first signal as an inverse function of the value of said second output signal.

5 Preferably, said amplification step is carried out in a variable gain amplifier, having a noninverting input, and step b) includes applying said first output signal (V+) to said noninverting input, and step d) includes applying said second output signal (V-) to said inverting input.

10 In a particular embodiment of the present invention, the method for detecting physical quantities further includes converting said output signal into digital form and sending it to an electronic processor to perform a linearity correction as a function of temperature changes
15 of said sensors based on predetermined data.

This and other features of the invention will be manifest from the following description of a preferred embodiment, made by way of a not limiting example, with reference to the attached drawings.

20 **Brief description of the drawings**

Fig. 1 depicts a functional block diagram of the humidity detection device, according to the present invention;

Fig. 2 depicts a humidity sensor used with the
25 circuit of Fig. 1;

Fig. 3 depicts the typically logarithmic variation law of the resistance as a function of the humidity of the sensor of Fig. 2;

Fig. 4 depicts the progression of the humidity representing signal at the amplifier output 10;

Fig. 5 depicts the progression of the humidity representing signal as applied to the A/D converter and, linearized, after the processing by the uP microprocessor;

Fig. 6 depicts the progression of the humidity representing signal at the noninverting input of the amplifier 10;

Fig. 7 depicts a different embodiment of the sensing circuit of Fig. 1.

Detailed description of a preferred embodiment

The following description relates to a preferred embodiment of a physical quantity, particularly humidity detection device, formed of a sensor and a sensing circuit.

Although the device described in the following example is relative to a humidity sensor, the sensing circuit is suitable to detect any type of physical quantity converted into electric signals by a suitable sensor; particularly, besides humidity, the circuit object of the present invention is suitable to detect other physical quantities, such as temperature, pressure, particular characteristics of chemical compounds, gas presence, etc., using only an appropriate sensor, sensitive to a specific physical quantity to be detected.

Referring to Fig. 1, an operational amplifier 10 having an output 12 and two inputs, respectively an inverting one 14 and a noninverting one 15, is connected to two sensors S1 and S2, arranged together in the same

environment where humidity is to be detected.

Preferably, the curves representing the resistance change of the two sensors S1 and S2 as a function of humidity have the same progression; particularly their
5 first and second derivatives are of the same sign.

More preferably, the two sensors S1 and S2 are equal, i.e. both have the same electric and, possibly, also mechanic characteristics.

In Fig. 2 one of the two sensors S1 and S2 is shown,
10 the structure thereof will be later described in detail.

Sensor S1 is connected with a terminal 24 to the noninverting input 15 and with another terminal 25 to a reference voltage $V_{ref.}$; sensor S2 is used as a feedback element of the amplifier 10, in order to modify the gain of
15 the amplifier itself, as it will be later explained; sensor S2 is thus inserted in the feedback path of the amplifier 10 and it is more exactly connected with a terminal 24' to the inverting input 14 and with a terminal 25' to the output 12 of the amplifier 10.

20 Sensors of a resistive type normally show a resistance changing as a function of humidity according to a strongly non-linear law and with a very wide range of values, covering many decades, for instance five to eight decades. Effectively, resistance change is very great at low
25 humidity values, while it approaches in an asymptotic way to zero Ohm at humidity values near to 100%. Such non-linear variation law substantially approximates a curve of a logarithmic type (Fig. 3): at low humidity values, the

sensor resistance has values of several MOhm, for example 5
÷ 20 MOhm (portion A); it falls quickly to values of some
tens of kOhm in the region of greater curvature (portion
B), with a humidity of 15 ÷ 40%, and it reaches in an
5 asymptotic way very low resistance values (portion C) in
the order of some kOhm, or even less, for humidity values
comprised between about 40% and 100%.

Sensor S1 is connected in parallel to a resistance R8
connected between terminals 24 and 25 of sensor S1, which
10 value is chosen substantially equal to the resistance value
of sensor S1 as measured at an intermediate humidity, e.g.
RH = 40 ÷ 50%.

Second sensor S2 is connected in series with a
resistance R2 of a value, for instance, of some kOhm. In
15 parallel to group S2, R2, a resistance R4 is connected, of
a value much higher than R2, for instance of some MOhm.

Any differences of the resistance value of one sensor
compared to the other can be compensated, at least
partially, by properly choosing the values of resistances
20 R2, R4 and R8.

Voltage response V_+ of sensor S1 applied to the
noninverting terminal 15 of the amplifier 10 is referred to
a reference voltage V_{ref} , as indicated in Fig. 1, wherein,
for example, a value of 2,5 Volts is assigned to the
25 reference voltage V_{ref} ; voltage V_{ref} is suitable to provide
to the operational amplifier 10, an operating voltage
level, intermediate between power supply and ground, to
which the response signal V_+ of the sensor S1 and the

driving voltages V_p are referred; the reference voltage is supplied by an auxiliary circuit 36, connected to the terminal 25 of sensor S1 and to the inverting input 14 of the amplifier 10, through resistance R6.

5 The analogue signal V_o at the output of amplifier 10 can be processed through processing known by those skilled in the art.

 The sensor S2 being inserted in the feedback branch of amplifier 10, and its resistance changes being proportional
10 to those of sensor S1, the amplifier 10 gain is modified with a progression congruent with the progression of the signal generated by sensor S1, but in an inverse way, producing, as a resulting signal at the output of amplifier
10, a voltage V_o (Fig. 4), having a substantially linear
15 progression, as the humidity value changes.

 The resistance R8, in parallel to sensor S1, intervenes to limit the voltage applied to the noninverting input 15, when sensor S1 shows very high voltage at low humidity values; while, at high humidity values, when
20 sensor S1 shows low resistance values, i.e. lower than resistance R8, the latter affects S1 in a negligible way.

 Resistances R2 and R4 act in a similar way; resistance R4 has a very high resistive value, as already mentioned, approximately of the same order of magnitude as the
25 resistance values of sensor S2 at low humidity; therefore resistances R2 and R4 intervene to limit the minimum and the maximum gain of the amplifier 10, respectively, when sensor S2 is plunged in an environment with very high or

very low humidity, respectively.

In case it is desired to increase the linearity degree of the response, the output 12 of the amplifier 10 is conveniently connected to an Analogue-to-Digital converter 5 30, of a type known in the art, which is in turn connected to a microprocessor uP; the converter 30 converts the analogue signal V_0 provided by the amplifier 10 and representative of the relative humidity value (RH) measured by sensor S1, into a digital signal suitable to be 10 processed by microprocessor uP.

The microprocessor uP processes humidity values received from converter 30 by means of a predetermined algorithm and based on corrective parameters stored in an electronic table 52, to perform a more exact linearization 15 of the analogue signal V_0 .

The content of table 52 is previously calculated by microprocessor uP, in an initial calibration step, or it is provided thereto based on previously detected data.

In case it is desirable to increase the linearity 20 degree of the response, eliminating or reducing the thermal drifts effects, data provided by a temperature compensation circuit 33 must be taken into account; the circuit 33, of a known type, detects and amplifies the signals generated by a resistance R_t , variable with sensor S1 temperature.

25 The processing of the signal V_0 by microprocessor uP actually consists of a double form of compensation; a first compensation is made to correct any deviation from linearity, using table parameters obtained from the

preliminary calibration, and a second temperature compensation using the response of the thermal compensation circuit 33.

Preferably, the two compensations are made
5 simultaneously.

At the end of the processing, the signal representing humidity values, variable according to a linear law, transformed by microprocessor uP, is represented by diagram V_{LIN} in Fig. 5.

10 The sensor S1 is driven by a voltage signal V_p , later referred to as the driving signal, generated by a circuit 34, which receives from microprocessor uP the activation signals suitable to drive sensor S1 in the most appropriate way in order to obtain, as a response, a measurement of
15 humidity as a function of the electro-physical characteristics of the sensitive material used.

In Fig. 6 the progression of the voltage signal V_+ at the sensor S1 output is represented; from this signal the impossibility is manifest of exactly reading on the curve
20 the change of voltage V_+ as humidity changes, in the case a voltage is applied to only one sensor, without making use of the invention device.

Description of the sensor

The two sensors S1 and S2, similar to each other, are
25 conveniently made with the same sensitive material, and the same construction specifics, electric (and possibly mechanic) characteristics, so that they have a resistance progression as a function of humidity as similar as

possible; particularly, it is appropriate that the curves representing the resistance change of the two sensors S1 and S2 as a function of humidity have first and second derivatives of the same sign (at least in the foreseen
5 measurement range).

In such a manner, it is obtained that an analogous behaviour occurs for both sensors in the resistance change with humidity (or other quantity) changes. For instance, this means that if, for one sensor, in a first humidity
10 range the resistance changes within a few Ohm, while in a second humidity range of a similar width the resistance changes by many tens of Ohm, for the other sensor it is necessary that the resistance increases by passing from the first to the second range and also that the resistance
15 increase changes in the same way.

The better linearization of the signal representing the humidity values V_{LIN} is obtained, the less the difference between the resistances of the two sensors, at a given humidity value.

20 The sensors S1 and S2 are comprised of a ceramic, porous support 16 (Fig. 2), e.g. of alumina, on which two arrays 18 and 19 of conductive electrodes 20 are placed, deposited with any one of the known electrodeposition processes with the aid of a mask; the electrodes of the two
25 arrays 18 and 19 are arranged in an interdigitated form, i.e. alternately interposed between and insulated from one another.

The conductors 20 of each array 18 and 19 respectively

lead to the two connection terminals 27 and 28, for the connection of the two sensors S1 and S2 to the operational amplifier 10 (Fig. 1).

A first layer 22 of a material sensitive to humidity is placed over the two arrays 18 and 19 of electrodes 20, and it is in turn covered by a second layer 23 of insulating, protective and permeable to water material.

The first layer 22 sensitive to humidity is comprised of one of the compounds known in the art, for example the compounds chosen among conductive hydrophilic polymers, sintered ceramic powders, resins, or properly treated metal salt-based compounds.

According to a preferred embodiment of the humidity detection device, according to the present invention, the first layer 22 sensitive to humidity of each of the two sensors S1 and S2 can be preferably comprised of a resistive type material, which has superior reproducibility and reliability characteristics and lower manufacturing costs with respect to other types of materials. For instance the sensor can have a size of 12 mm x 5 mm x 0,5 mm and for the layer 22 a polyelectrolyte can be used, as for example sodium sulphate polystyrene (NaPSS).

A sensor of this kind is described in the Chinese patent CN 2543063Y.

The second protective layer 23 is preferably comprised of a material permeable to water, as for example, a celluloid layer.

Description of an alternative form of the sensing

circuit

Referring to Fig. 7, a different embodiment of a humidity sensing circuit according to the invention is described by way of a not limiting example, that is suitable to be associated to two sensors which use a humidity sensitive material comprised of a ionic conduction polymeric electrolyte, of the type of the one described in the U.S. patent n°4,642,601.

Therefore in Fig. 7 the portion regarding the amplifier 10 and the related passive components, enclosed in a dashed rectangle 31, and that for simplicity are called detection means, does not change and its description will not be repeated here.

Using, as humidity sensitive material, a ionic conduction material, humidity detection is based on a characteristic property of such material, i.e. on the phenomenon according to which the ionic dissociation degree changes, according to whether the humidity level increases or decreases; on the ionic concentration in the material depend the electric characteristics of the material itself, and particularly the capability of separating positive from negatives ions, upon application of a potential difference; in other words, as the humidity level changes, the ionic dissociation degree correspondingly changes, causing a related change of the electric impedance of the sensitive material.

In the specific case, the sensors S1 and S2 have an electric impedance, as seen from connection terminals 27

and 28, created by a resistance R_s in parallel to a capacity C_s , wherein its value is normally very little, so that due to the resistance R_s effect prevailing over the capacity C_s , the impedance change as humidity changes takes
5 up a progression similar to that of a sensor of the resistive type, i.e. according to a substantially logarithmic law (Fig. 3).

Because the electric response of the ionic conduction polymeric material that comprises the sensitive layer of
10 the sensors S1 and S2 is determined, as seen above, by the transportation of ions and the capacitance between electrodes connected to it, to measure the polyelectrolyte impedance as a function of environmental humidity, the sensor S1 is driven with a driving signal comprised of an
15 alternating voltage V_p ; such alternating voltage is preferably comprised of two successive square waves.

The driving signals are generated by a circuit 34' (Fig. 7), comprised of a pair of transistors Tr1 and Tr2 of opposed polarity and connected in series between the supply
20 voltage V and the ground 35; transistors Tr1 and Tr2 bases are alternately driven by microprocessor uP, which, in a way known to those skilled in the art, is programmed to send activation pulses for one or the other of the transistors Tr1, Tr2, properly clocked.

25 The analogue signal V_o , representative of the humidity value at the output 12 of the amplifier 10, is sent through a resistance R3 to the inverting input 39 of a second operational amplifier 40, to adapt the level of signal V_o .

to the characteristics of a converter 30, for a subsequent conversion of the signal V_o into digital form. At the output 41 of the amplifier 40 there is thus a signal V_2 corresponding to the signal V_o , but overturned, as indicated in Fig. 5.

The sensing circuit of Fig. 7 also includes a circuit 33', similar to circuit 33 of Fig. 1, for compensating the temperature of sensors S1 and S2, wherein an operational amplifier 50 amplifies a signal generated by a thermistor R_t , which detects temperature changes in the proximity of sensors S1 and S2, and sends such amplified signal to microprocessor uP, which, by means of an algorithm, calculates corrective coefficients which are preliminarily stored in the table 52, contained in an internal memory of the same microprocessor.

Signals V_o and V_{LIN} respectively present at output 12 of the amplifier 10 and at output OUT of the microprocessor uP relating to the circuit of Fig. 7, are represented in figures 4 and 5.

It is understood that modifications and/or replacements of components can be made to the humidity detection device, according to the present invention, without however departing from the scope of the invention.

For example, the operational amplifier 10 can be replaced by an amplifier circuit made with discrete components, as junction transistors, or field effect transistors, and with their relative resistive and capacitive polarization and compensation components,

respectively.

Similarly, sensors S1 and S2 can be made with different materials from those indicated in the description of the sensor of Fig. 2; for example, the support 16 can be
5 made with a semiconductor silicon chip, passivated with a layer of silicon oxide and protected by a layer of silicon carbide and nitride, superposed to the silicon oxide layer.

The electrodes 20 are deposited through any of the well-known methods of thin film deposition with the aid of
10 masks. Preferably, the electrodes 20 are obtained by evaporation or sputtering.

Both the sensors S1 and S2 and the detection circuit 31 can be manufactured with the known miniaturizing techniques and enclosed in a metallic capsule, provided
15 with suitable openings for the passage of humidity of the environment where the capsule is placed. The other circuit components illustrated in Fig. 7, being bigger, are normally placed in a remote position relative to the capsule, and connected to it through cables.

CLAIMS

1. A physical quantity detection device, including a sensor (S1), sensitive to said physical quantity and exposed thereto, and an amplifier (10), connected to the output of said sensor with a first input (15) and having a second reference input (14), characterized in that it comprises a second sensor (S2), sensitive to said physical quantity and exposed thereto, connected to the amplifier output (12) and connected also to said reference input (14).

2. A detection device, according to claim 1, characterized in that said amplifier (10) is an operational amplifier, wherein said first sensor (S1) is connected between a noninverting input (15) and a source (36) of a reference voltage (Vref), and wherein said second sensor (S2) is arranged in the feedback line of said amplifier (10), being connected between said output (12) and an inverting input (14) of said amplifier (10).

3. A detection device, according to claim 1 or 2, characterized in that said first and second sensors (S1, S2) are made with the same sensitive material.

4. A detection device, according to one of the preceding claims, characterized in that the curves representing the resistance change of said first sensor (S1) and of said second sensor (S2) as a function of the physical quantity to be detected have the same sign of the first derivative and second derivative.

5. A detection device, according to one of the

preceding claims, characterized in that said particular physical quantity is the relative humidity present in the environment where said sensors (S1, S2) are arranged.

6. A detection device, according to claim 2,
5 characterized in that it further comprises a resistance (R8) connected in parallel to said first sensor (S1), to limit the resistance applied to said first input (15), when said first sensor (S1) has a very high resistance at low humidity values.

10 7. A detection device, according to claim 2 or 6, characterized in that it comprises a second resistance (R2) connected in series to said second sensor (S2) and a third resistance (R4) connected in parallel to both said second sensor (S2) and said second resistance (R2), to limit the
15 minimum and maximum gain of said amplifier (10), respectively, when said second sensor (S2) is plunged in an environment with very high or very low humidity, respectively.

8. A detection device, according to claim 6 or 7,
20 characterized in that said first sensor (S1) is connected between a generator (34, 34') of driving signals (Vp) and said reference voltage generator (36), said driving signals activating said first sensor (S1) to generate said response signal (V+), variable as humidity changes.

25 9. A detection device, according to claim 8, characterized in that said driving signals are comprised of a direct voltage, referred to said reference voltage (Vref).

10. A detection device, according to claim 8, characterized in that said driving signals are comprised of at least two homopolar square waves, having a pre-determined duration.

5 11. A detection device, according to claim 8, characterized in that said driving signals are comprised of at least two square waves of opposed polarity, and having a null average value, coinciding with said reference voltage (V_{ref}).

10 12. A detection device, according to claim 10 or 11, characterized in that said at least two square waves have the same amplitude (V_p).

15 13. A detection device, according to claim 9, characterized in that said driving signals are referred to said reference voltage (V_{ref}).

14. A detection device, according to one of the preceding claims, characterized in that each of said sensors (S_1 , S_2) includes a double array (18, 19) of electric conductors (20) separated from one another, deposited on an insulating support (16) and respectively connected to said pair of electric terminals (27, 28), said electric conductors (20) being covered with a layer (22) of a material sensitive to one of said particular physical quantities, and with a permeable layer (23) laid upon said sensitive layer (22).

25 15. A detection device, according to claim 14, characterized in that said particular physical quantity is the relative humidity present in the environment where said

sensors (S1, S2) are arranged.

16. Method for detecting physical quantities, providing the following steps:

a) driving a first sensor (S1) of a physical quantity
5 with a predetermined driving signal (V_p) in order to obtain a first output signal (V_+), function of the physical quantity;

b) amplifying the first output signal and obtaining an amplified signal (V_o) in response to said first output
10 signal;

c) driving a second sensor S2, arranged in the same environment as the first sensor S1, with a driving signal comprised of the amplified signal (V_o) and obtaining a second output signal (V_-);

d) continuously adjusting the amplification gain of
15 said first signal (V_+) as an inverse function of the value of said second output signal (V_-).

17. A method for detecting physical quantities according to claim 16, characterized in that the curves
20 representing the resistance change of said first sensor (S1) and of said second sensor (S2) as a function of the physical quantity to be detected have the same sign of first derivative and second derivative.

18. A method for detecting physical quantities
25 according to claim 16 or 17, characterized in that said amplification step is carried out in a variable gain amplifier, having a noninverting input, and step b) includes applying said first output signal (V_+) to said

noninverting input.

19. A method for detecting physical quantities according to one of claims 16-18, characterized in that said amplification step is carried out in a variable gain amplifier, having an inverting input, and step d) includes:

5 applying said second output signal (V_-) to said inverting input.

20. A method for detecting, according to one of claims 16-19, further comprising:

10 e) converting said output signal (V_o) into digital form and sending it to an electronic processor (uP) to carry out a linearity correction as a function of the temperature changes of said sensors (S1 and S2) based on predetermined data.

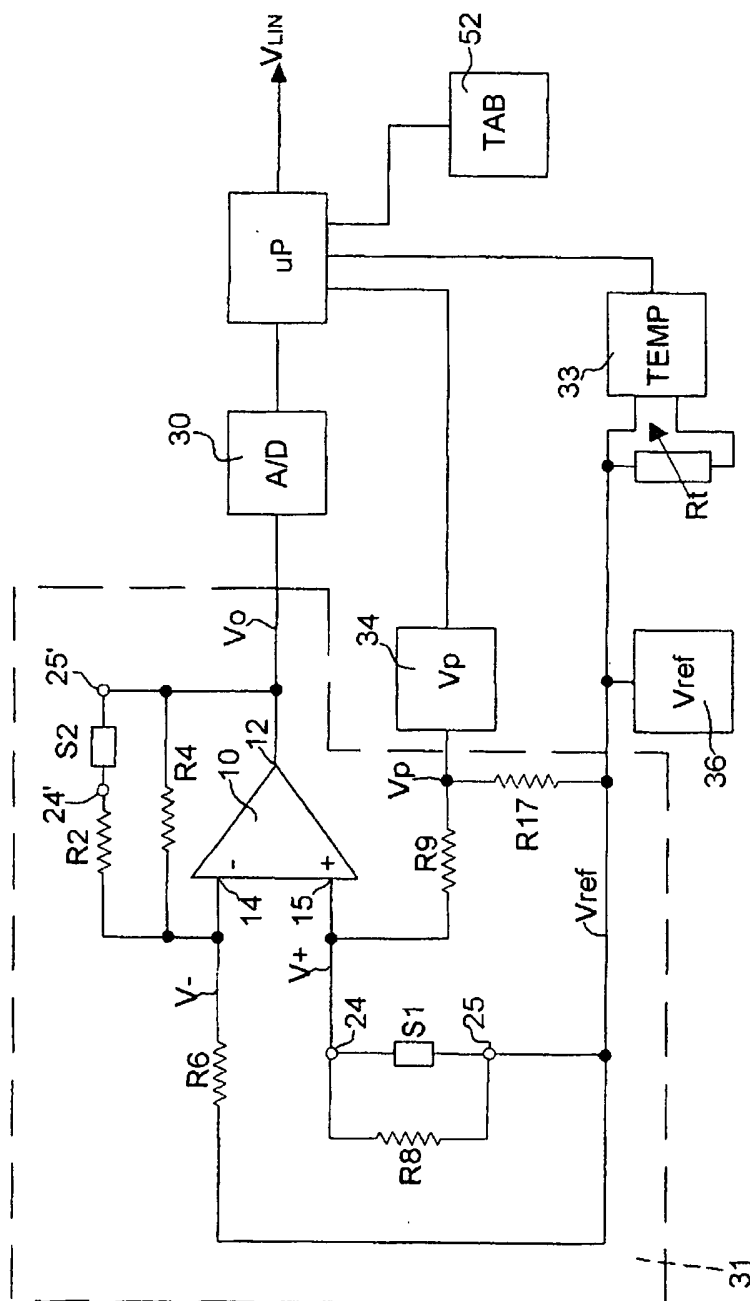

Fig. 1

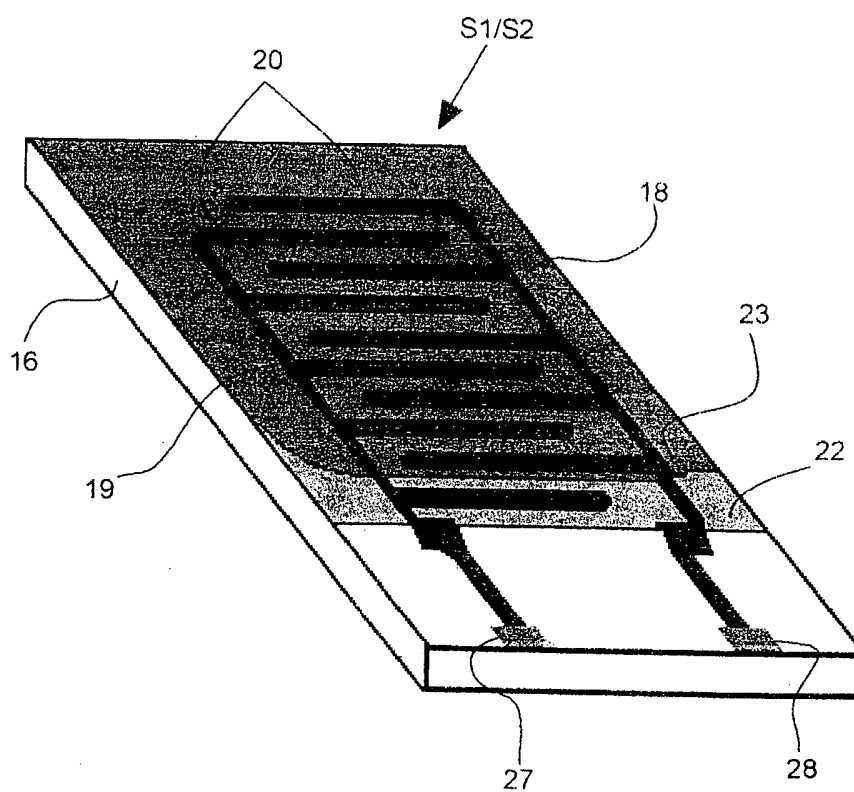

Fig. 2

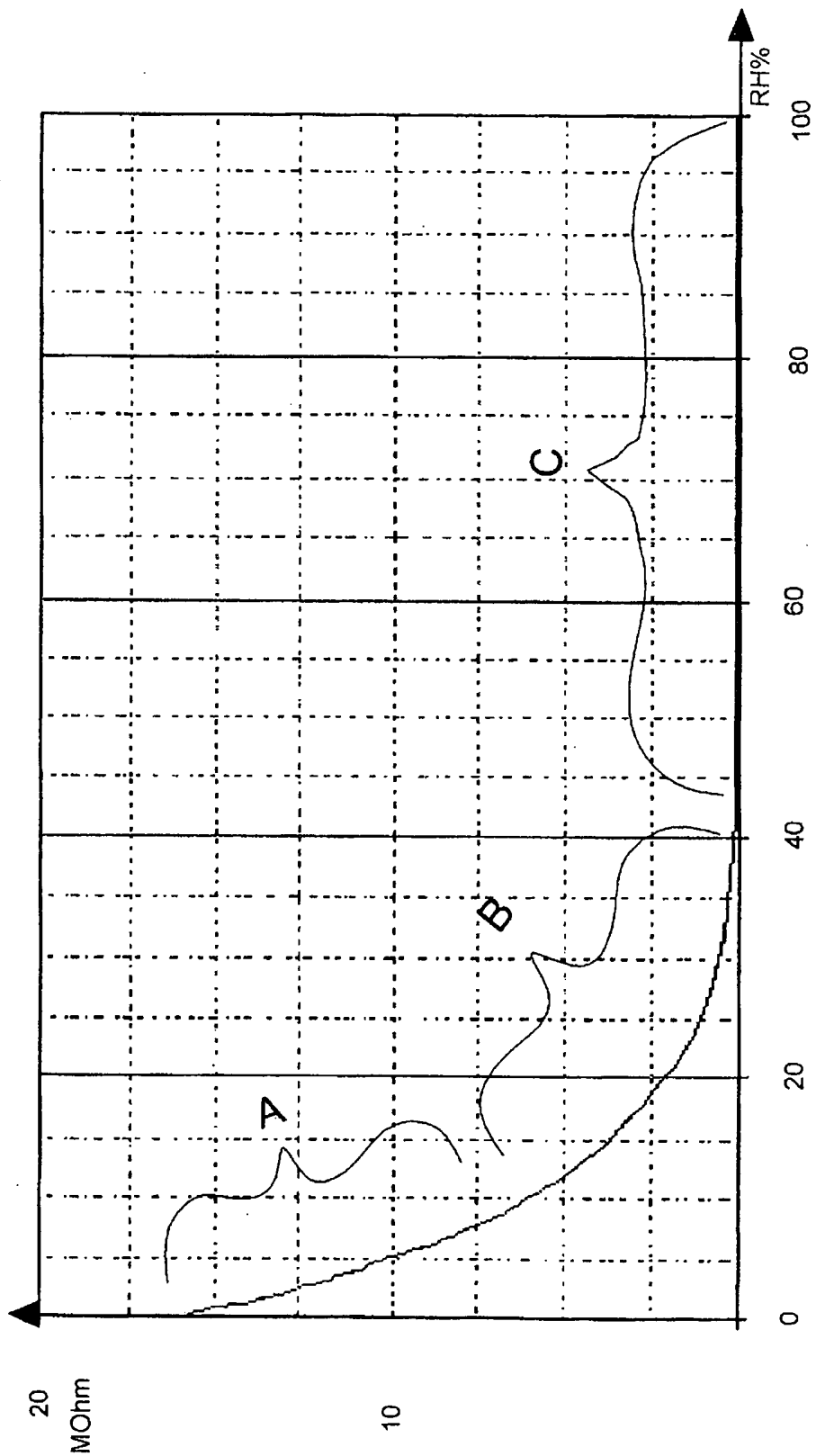

Fig. 3

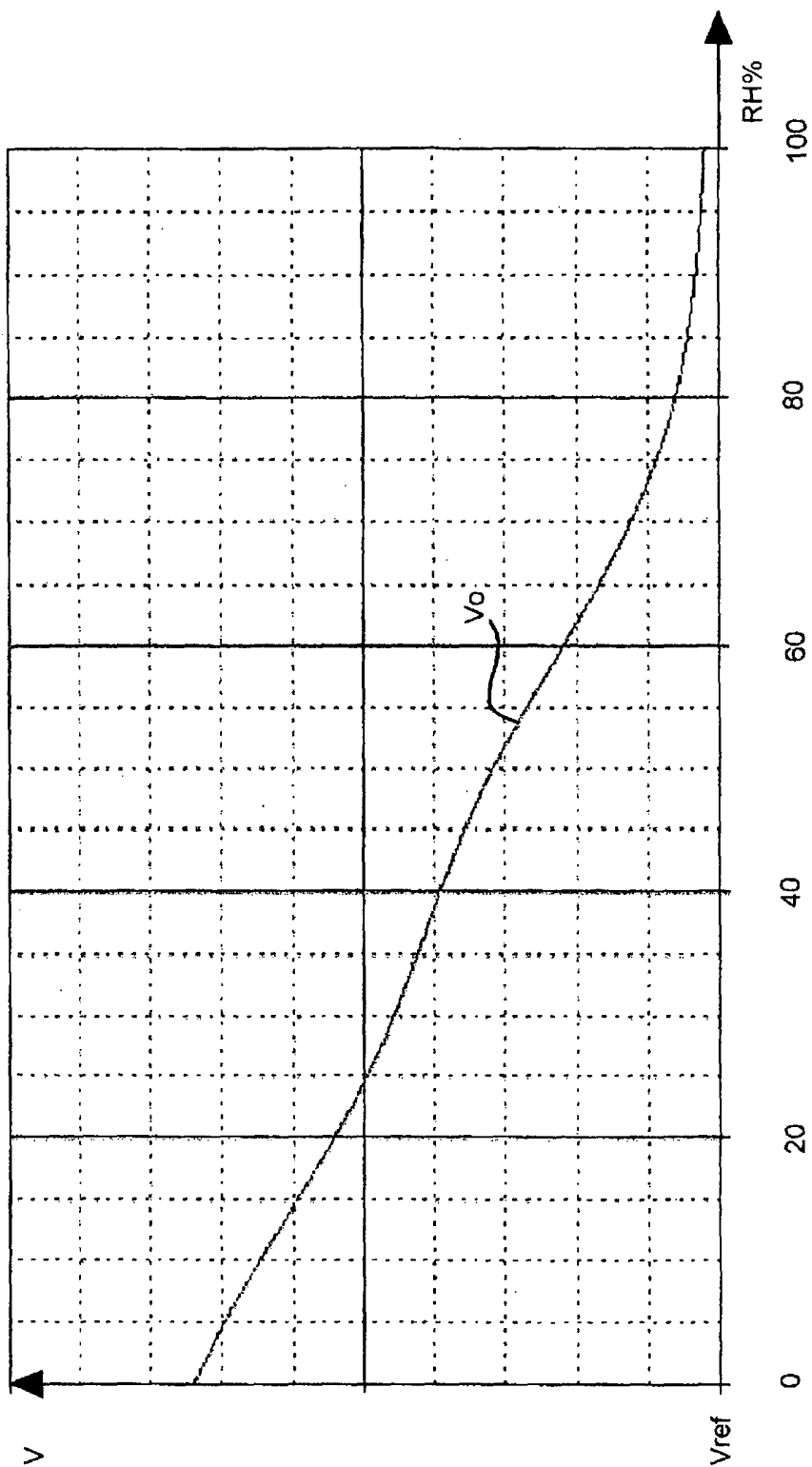

Fig. 4

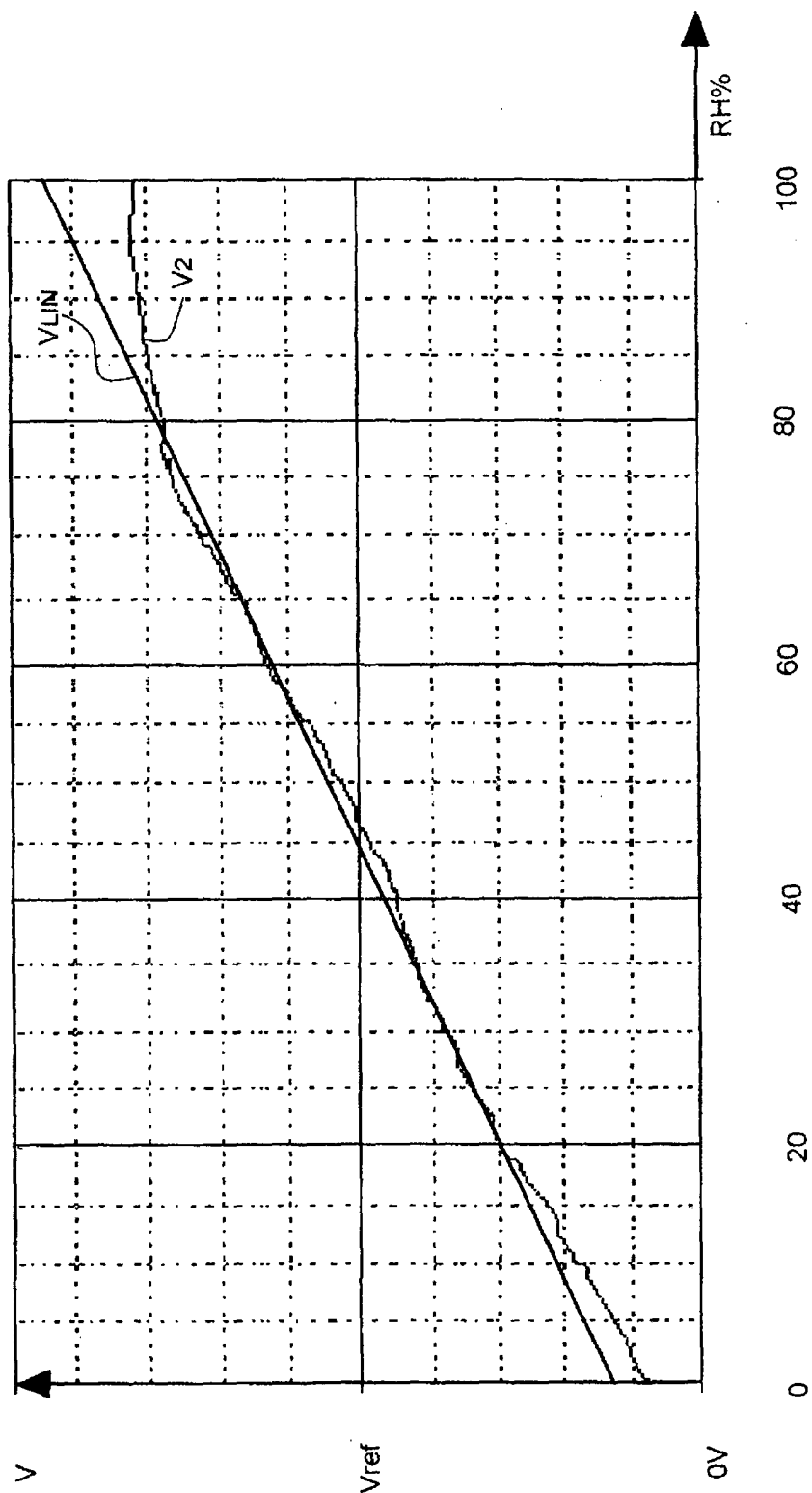

Fig. 5

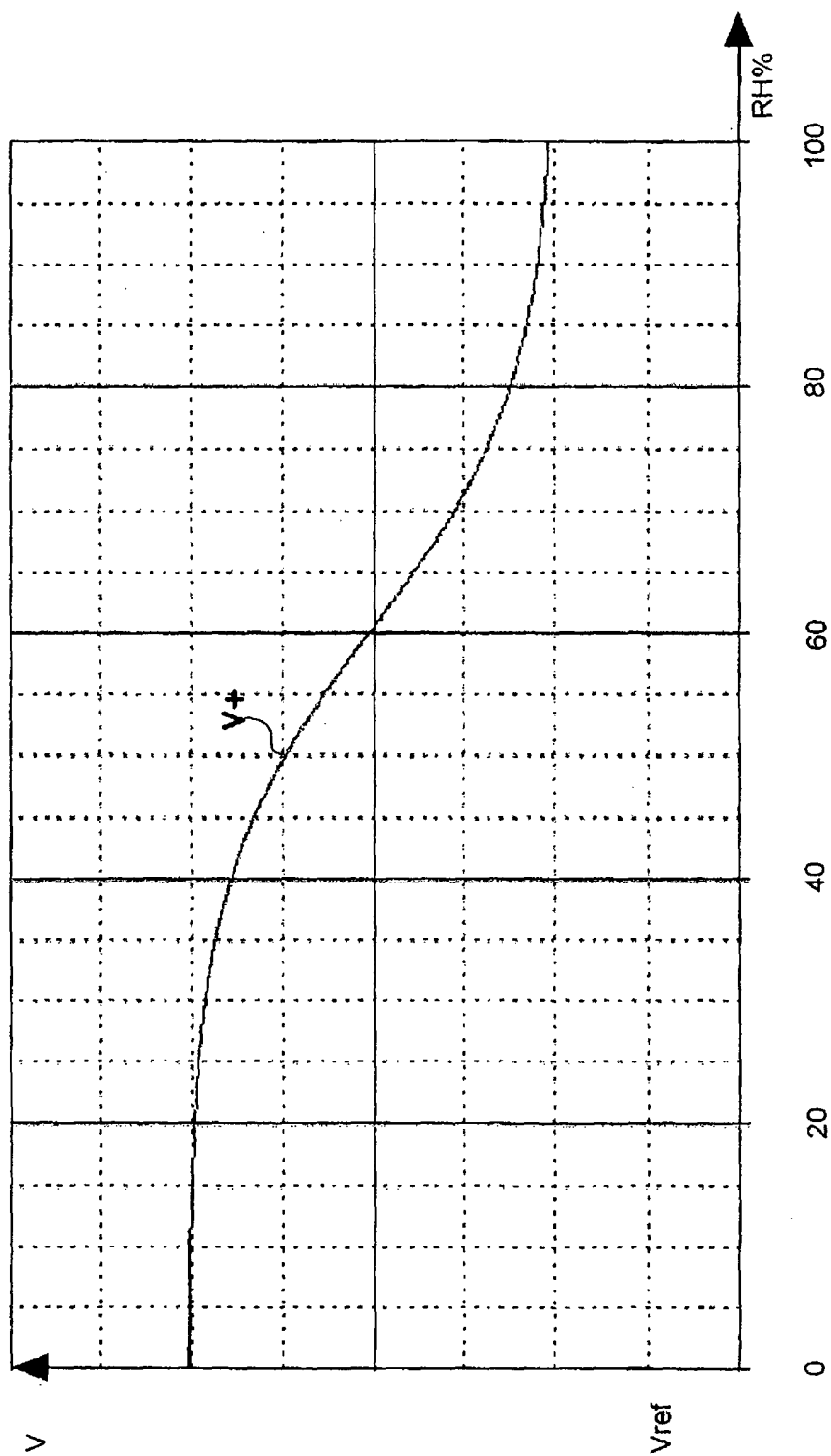

Fig. 6

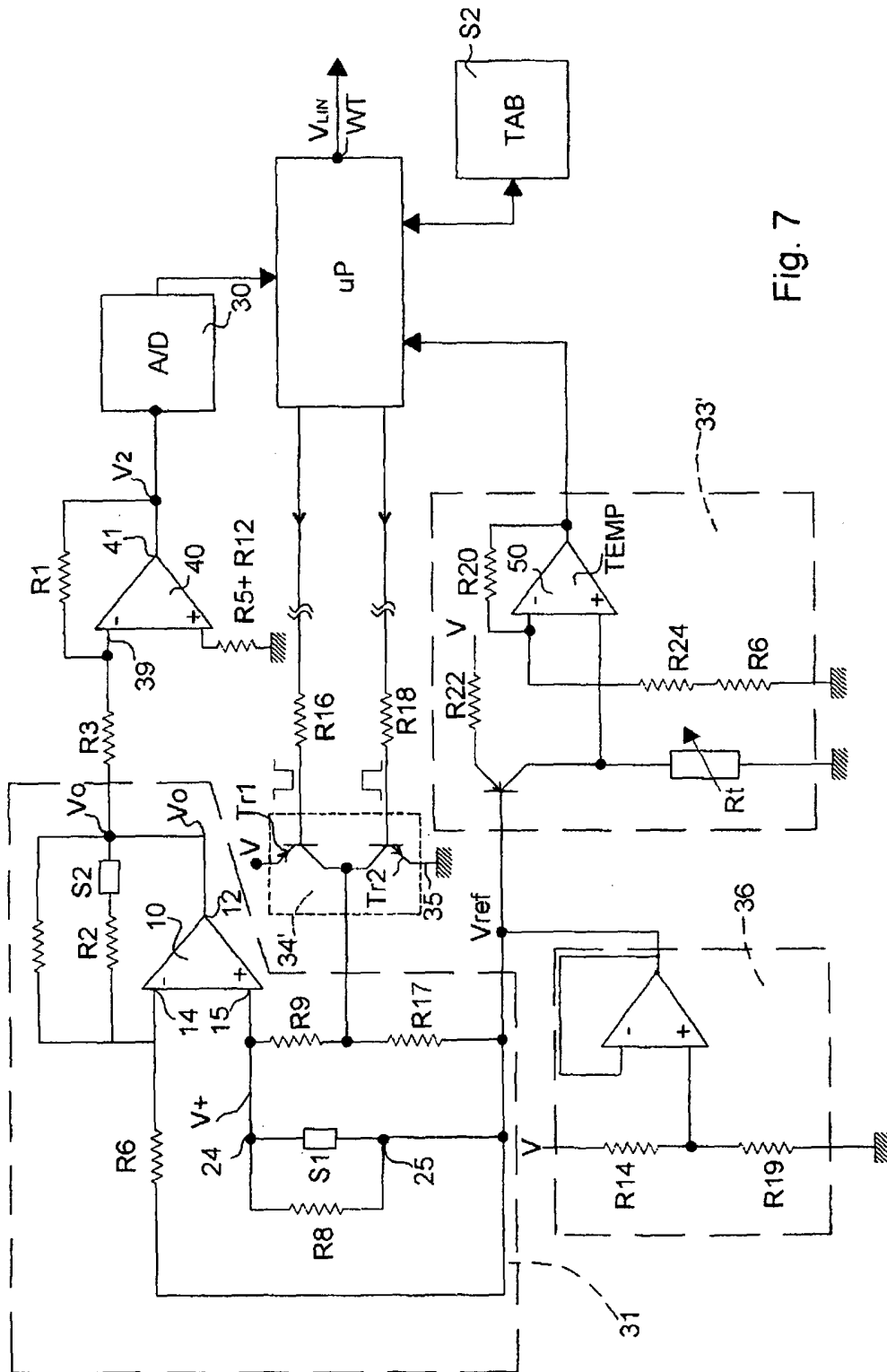

Fig. 7

INTERNATIONAL SEARCH REPORT

International Application No

PCT/EP2005/006349

A. CLASSIFICATION OF SUBJECT MATTER
 IPC 7 G01N27/12 G01N33/00

According to International Patent Classification (IPC) or to both national classification and IPC

B. FIELDS SEARCHED

Minimum documentation searched (classification system followed by classification symbols)
 IPC 7 G01N

Documentation searched other than minimum documentation to the extent that such documents are included in the fields searched

Electronic data base consulted during the international search (name of data base and, where practical, search terms used)

EPO-Internal, WPI Data

C. DOCUMENTS CONSIDERED TO BE RELEVANT

Category °	Citation of document, with indication, where appropriate, of the relevant passages	Relevant to claim No.
X	EP 0 942 281 A (EPCOS AG) 15 September 1999 (1999-09-15) paragraphs '0001!', '0047!', '0050! - '0058!; figures 1,2 -----	1-20
X	EP 0 884 592 A (CTS CORPORATION) 16 December 1998 (1998-12-16) page 4, lines 25-55; figure 2 -----	1
A	EP 0 687 903 A (TDK CORPORATION) 20 December 1995 (1995-12-20) column 17, line 48 - column 18, line 15; figures 1,7,13 -----	2-20
A	EP 0 687 903 A (TDK CORPORATION) 20 December 1995 (1995-12-20) column 17, line 48 - column 18, line 15; figures 1,7,13 -----	1-20
A	US 4 572 900 A (WOHLTJEN ET AL) 25 February 1986 (1986-02-25) column 4, lines 4-26; figure 1 -----	1-20
	-/--	

Further documents are listed in the continuation of box C.

Patent family members are listed in annex.

° Special categories of cited documents:

- *A* document defining the general state of the art which is not considered to be of particular relevance
- *E* earlier document but published on or after the international filing date
- *L* document which may throw doubts on priority claim(s) or which is cited to establish the publication date of another citation or other special reason (as specified)
- *O* document referring to an oral disclosure, use, exhibition or other means
- *P* document published prior to the international filing date but later than the priority date claimed

- *T* later document published after the international filing date or priority date and not in conflict with the application but cited to understand the principle or theory underlying the invention
- *X* document of particular relevance; the claimed invention cannot be considered novel or cannot be considered to involve an inventive step when the document is taken alone
- *Y* document of particular relevance; the claimed invention cannot be considered to involve an inventive step when the document is combined with one or more other such documents, such combination being obvious to a person skilled in the art.
- *Z* document member of the same patent family

Date of the actual completion of the international search

4 October 2005

Date of mailing of the international search report

12/10/2005

Name and mailing address of the ISA
 European Patent Office, P.B. 5818 Patentlaan 2
 NL - 2280 HV Rijswijk
 Tel. (+31-70) 340-2040, Tx. 31 651 epo nl,
 Fax: (+31-70) 340-3016

Authorized officer

Wulveryck, J-M

INTERNATIONAL SEARCH REPORT

International Application No
PCT/EP2005/006349

C.(Continuation) DOCUMENTS CONSIDERED TO BE RELEVANT

Category °	Citation of document, with indication, where appropriate, of the relevant passages	Relevant to claim No.
A	EP 0 816 805 A (YOZAN INC; SUMITOMO METAL INDUSTRIES, LTD; TOKYO ELECTRON LTD) 7 January 1998 (1998-01-07) page 4, lines 56-58; figure 13 -----	1-20
A	EP 0 844 477 A (PITWAY CORPORATION) 27 May 1998 (1998-05-27) figure 3 -----	1,16

INTERNATIONAL SEARCH REPORT

Information on patent family members

International Application No

PCT/EP2005/006349

Patent document cited in search report	A	Publication date	Patent family member(s)	Publication date
EP 0942281	A	15-09-1999	DE 19811069 A1	07-10-1999
EP 0884592	A	16-12-1998	CA 2238464 A1 JP 11014580 A US 5918260 A	11-12-1998 22-01-1999 29-06-1999
EP 0687903	A	20-12-1995	DE 69523985 D1 DE 69523985 T2 JP 2795807 B2 JP 8005590 A US 5652382 A	03-01-2002 04-04-2002 10-09-1998 12-01-1996 29-07-1997
US 4572900	A	25-02-1986	NONE	
EP 0816805	A	07-01-1998	DE 69727855 D1 DE 69727855 T2 JP 3255273 B2 JP 10009892 A US 5973538 A	08-04-2004 29-07-2004 12-02-2002 16-01-1998 26-10-1999
EP 0844477	A	27-05-1998	CA 2221678 A1	22-05-1998