



(19) **United States**

(12) **Patent Application Publication**
Tsurube et al.

(10) **Pub. No.: US 2013/0278803 A1**

(43) **Pub. Date: Oct. 24, 2013**

(54) **IMAGING DEVICE, IMAGING METHOD AND PROGRAM**

Publication Classification

(71) Applicant: **Panasonic Corporation**, Osaka (JP)

(51) **Int. Cl.**
H04N 5/357 (2006.01)

(72) Inventors: **Tomoyuki Tsurube**, Tokyo (JP); **Keiji Toyoda**, Kanagawa (JP); **Nobuyuki Hirose**, Tokyo (JP)

(52) **U.S. Cl.**
CPC **H04N 5/357** (2013.01)
USPC **348/300**

(21) Appl. No.: **13/923,805**

(57) **ABSTRACT**

(22) Filed: **Jun. 21, 2013**

Of the output signals of a solid state image sensor 101, only the signals in a vertical OB line period are selected by an OB line selector 105. A level adjuster 107 adjusts the level of a past vertical OB line signal read out from the line memory 106 during a first vertical OB line period of a frame where the amplification factor of an amplifier 102 has changed, and outputs the same. A subtractor 109 subtracts the signal whose level has been adjusted from a current vertical OB line signal. A multiplier 111 multiplies, via a selector B 110, the signal after subtraction by a cyclic coefficient K_{1H} for the first vertical OB line period of the frame where the amplification factor has changed. A subtractor 112 subtracts the multiplication result from the current vertical OB line signal, and rewrites the subtraction result to the line memory 106.

Related U.S. Application Data

(63) Continuation of application No. PCT/JP2011/003550, filed on Jun. 22, 2011.

Foreign Application Priority Data

Feb. 21, 2011 (JP) 2011-034491

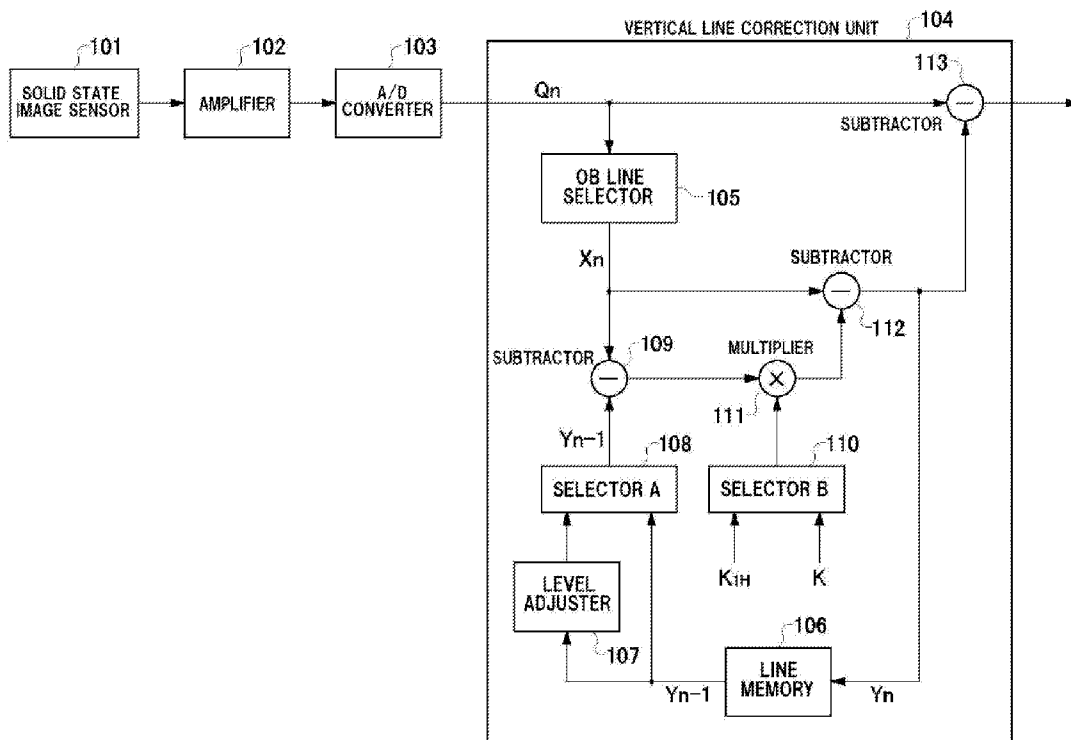

【Fig. 1】

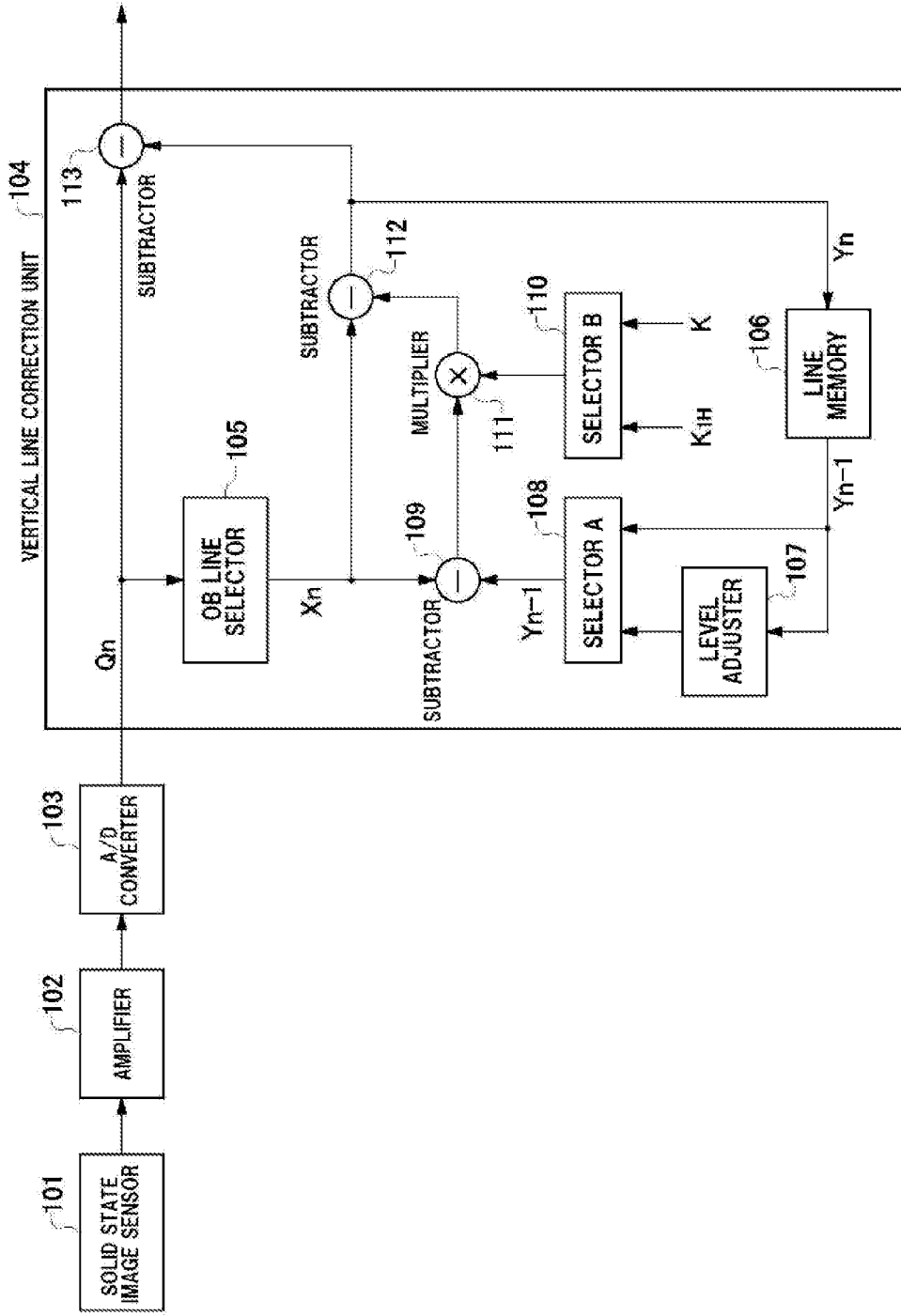

【Fig. 2】

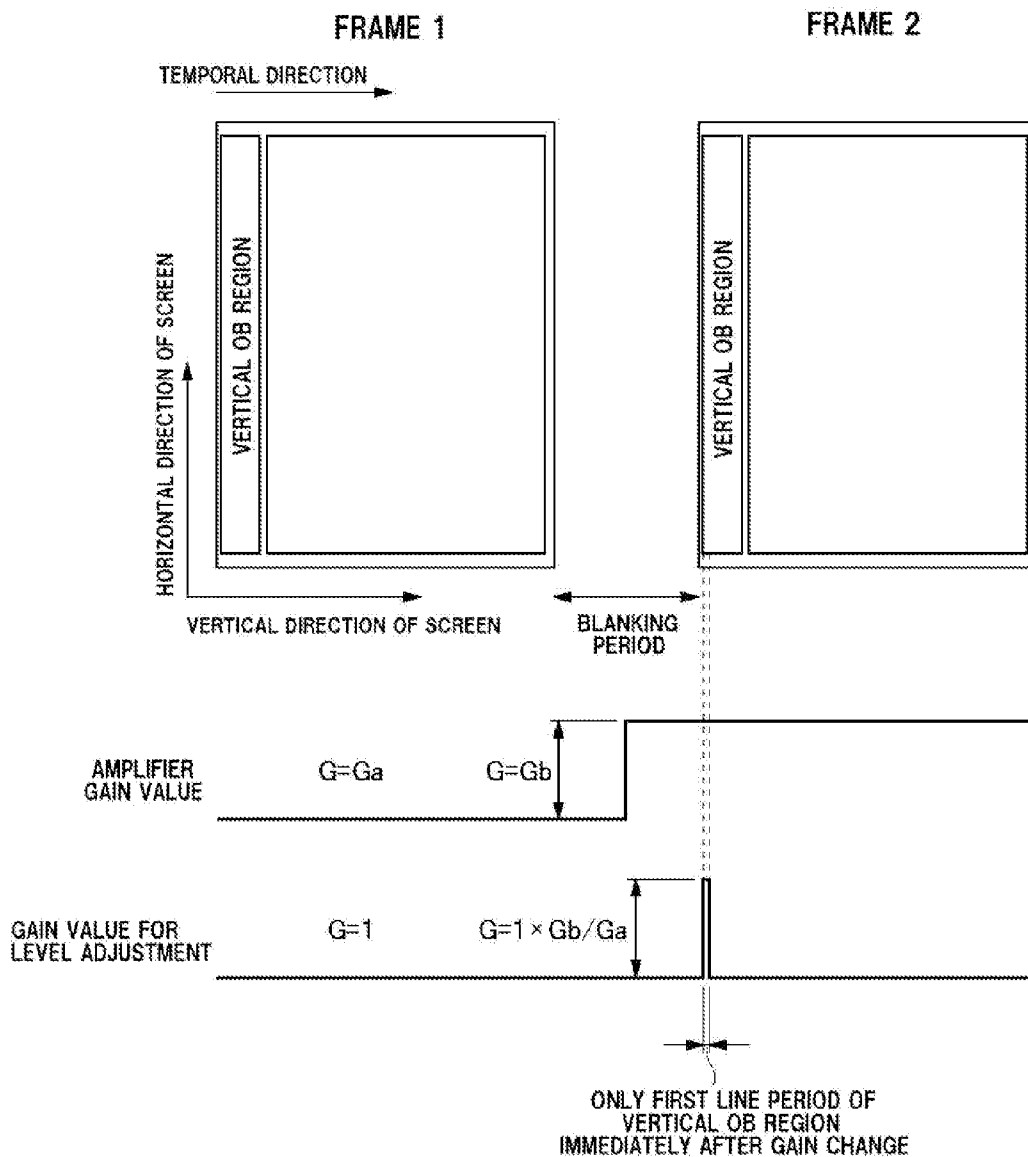

【Fig. 3】

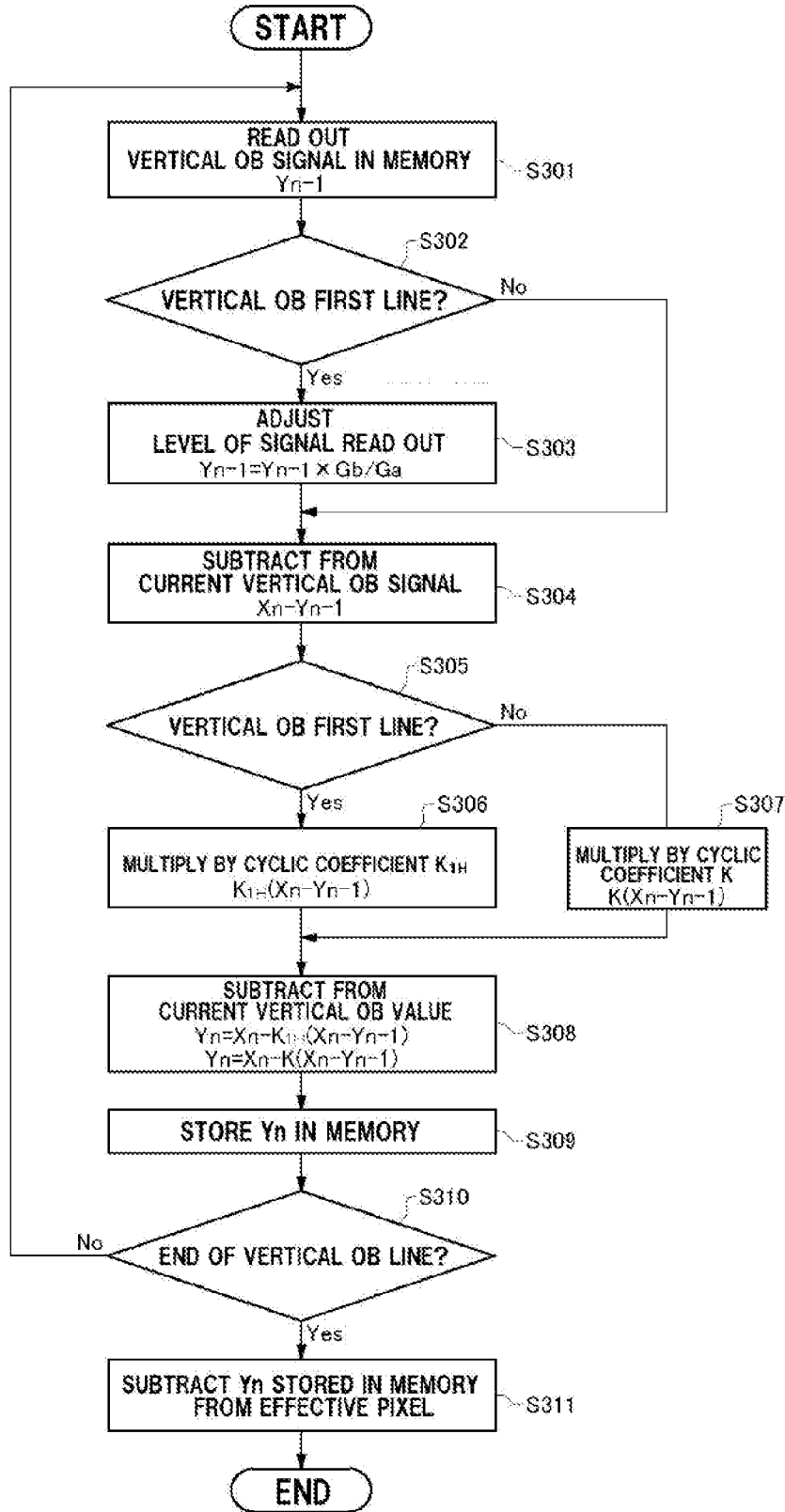

【Fig. 4】

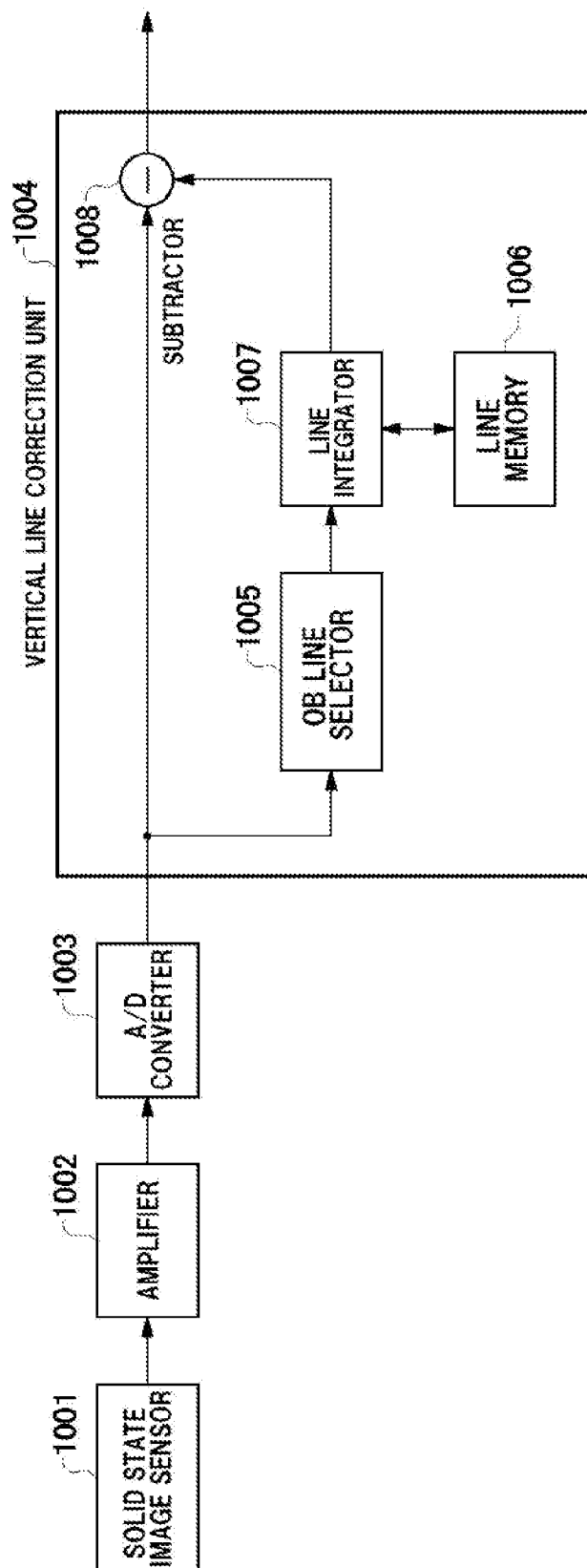

IMAGING DEVICE, IMAGING METHOD AND PROGRAM

TECHNICAL FIELD

[0001] The present invention relates to an imaging device that uses a solid state image sensor, an imaging method and a program.

BACKGROUND ART

[0002] Conventionally, an imaging device that uses a solid state image sensor has a problem concerning image quality deterioration due to cyclic clock noise due to system or noise due to a defect in a vertical transfer register. Although the level itself of the noise is extremely low, the noise shows on a screen as fixed vertical line noise and is highly visible, resulting in significant deterioration in the image quality. Furthermore, a smear phenomenon of linear blown-out highlights occurring on the overall image at the time of imaging an object with much higher brightness than its surroundings is also one of the main causes of image quality deterioration.

[0003] A method of removing such vertical line noise is being studied, and Patent Literature 1 (Japanese Patent Laid-Open No. 7-67038) discloses a method of reducing white lines or the like and the smear by integrating (averaging) output signals of an optical black pixel part in the vertical direction (vertical OB region) of a solid state image sensor on a per pixel basis and averaging random noise components to zero to thereby detect a fixed pattern noise signal, and subtracting the fixed pattern noise signal from output signals of an effective pixel part of the solid state image sensor.

[0004] FIG. 4 is a block diagram showing an overview of an example configuration of a conventional imaging device at the time of performing correction of vertical line noise (hereinafter, referred to simply as "vertical line") using a vertical OB region as described above which is an optically black region.

[0005] As shown in FIG. 4, an output signal from a solid state image sensor **1001** is amplified by an amplifier **1002**, quantized by an AD converter **1003**, and then input to a vertical line correction unit **1004**.

[0006] The vertical line correction unit **1004** includes an OB line selector **1005**, a line memory **1006**, a line integrator **1007**, and a subtractor **1008**.

[0007] Of the signals of an effective pixel region and the signals of a vertical OB region, the OB line selector **1005** outputs only the signals of the vertical OB region. The line integrator **1007** line-integrates (averages) the signals of the vertical OB region on a per pixel basis using the line memory **1006**. Random noise is thereby removed, and a correction value for one line is obtained. This correction value is stored in the line memory **1006**. The line integrator **1007** reads out the correction value stored in the line memory **1006**, and outputs the same to the subtractor **1008**. The subtractor **1008** subtracts the correction value described above from each line signal input from the solid state image sensor **1001** on a per pixel basis. A signal from which the vertical line noise is removed (which has been corrected in terms of vertical lines) is obtained in this manner.

CITATION LIST

Patent Literature

[0008] Patent Literature 1: Japanese Patent Laid-Open No. 7-67038

SUMMARY OF INVENTION

Technical Problem

[0009] However, with a conventional method as described above, if the number of lines in the vertical OB region provided in the solid state image sensor is small, the number of times of averaging per one pixel in the vertical direction at the time of performing line integration (averaging) in a frame is reduced, and the noise is sometimes not sufficiently reduced, and the noise may remain in the signal after correction. Also, in the case of performing averaging between frames, the noise and vertical lines may remain especially if the gain of the amplifier **1002** of the imaging device is changed between the frames.

[0010] The present invention is made in view of the issues of a conventional imaging device as described above, and its object is to provide a technique for obtaining high image quality by appropriately performing vertical line correction even if the number of lines in a vertical OB region is small or the gain of an amplifier is changed between frames.

Solution to Problem

[0011] To solve the issue described above, an imaging device of the present invention includes a solid state image sensor including an optical black region, and a vertical line correction unit for performing vertical line correction on an output signal of the solid state image sensor, wherein the vertical line correction unit includes an OB line selector for selecting an optical black line signal included in output signals of the solid state image sensor, a memory for storing the optical black line signal, a level adjuster for adjusting a level of an optical black line signal of a past frame read out from the memory, according to a video gain of the output signal of the solid state image sensor, a first subtractor for calculating a difference signal between a first optical black line signal of a current frame and the optical black line signal of the past frame whose level has been adjusted, a multiplier for calculating a product by multiplying the difference signal by a cyclic coefficient, a second subtractor for obtaining a signal which is the optical black line signal of the current frame from which the product of the difference signal and the cyclic coefficient has been subtracted, and rewriting the signal after subtraction to the memory as an optical black line signal, and a third subtractor for subtracting a signal read out from the memory from an output signal from an effective pixel region of the solid state image sensor.

[0012] Also, an imaging method of the present method is an imaging method of performing vertical line correction on an output signal of a solid state image sensor including an optical black region, the method including a step of selecting an optical black line signal included in output signals of the solid state image sensor, a step of storing the optical black line signal in a memory, a step of reading an optical black line signal of a past frame from the memory and adjusting a level according to a video gain of the output signal of the solid state image sensor, a first subtracting step of calculating a difference signal between a first optical black line signal of a current frame and the optical black line signal of the past frame whose level has been adjusted, a step of calculating a product by multiplying the difference signal by a cyclic coefficient, a second subtracting step of obtaining a signal which is the optical black line signal of the current frame from which the product of the difference signal and the cyclic coefficient

has been subtracted, and rewriting the signal after subtraction to the memory as an optical black line signal, and a third subtracting step of subtracting a signal read out from the memory from an output signal from an effective pixel region of the solid state image sensor.

[0013] Furthermore, a program of the present invention is a program for performing vertical line correction on an output signal of a solid state image sensor including an optical black region, the program being for causing a computer to execute the following steps: a step of selecting an optical black line signal included in output signals of the solid state image sensor, a step of storing the optical black line signal in a memory, a step of reading an optical black line signal of a past frame from the memory and adjusting a level according to a video gain of the output signal of the solid state image sensor, a first subtracting step of calculating a difference signal between a first optical black line signal of a current frame and the optical black line signal of the past frame whose level has been adjusted, a step of calculating a product by multiplying the difference signal by a cyclic coefficient, a second subtracting step of obtaining a signal which is the optical black line signal of the current frame from which the product of the difference signal and the cyclic coefficient has been subtracted, and rewriting the signal after subtraction to the memory as an optical black line signal, and a third subtracting step of subtracting a signal read out from the memory from an output signal from an effective pixel region of the solid state image sensor.

Advantageous Effects of Invention

[0014] According to the present invention, even when the number of lines in a vertical OB region is small, noise is effectively reduced by a cyclic operation between frames, and appropriate vertical line correction may be performed. Also, even when the gain of an amplifier of the imaging device is changed between frames, the level of a vertical OB line signal cycled to the previous frame may be adjusted to the extent of a change in a video level and be cycled. As a result, vertical line correction may be performed while reducing the correction residue by causing the level of a vertical line correction signal to follow the video level change such as a change in an amplification factor.

BRIEF DESCRIPTION OF DRAWINGS

[0015] FIG. 1 is a block diagram showing a configuration of an imaging device according to an embodiment.

[0016] FIG. 2 is an explanatory diagram of gain adjustment by the imaging device according to the embodiment.

[0017] FIG. 3 is a flow chart of signal processing according to the embodiment.

[0018] FIG. 4 is a block diagram showing an overview of an example configuration of a conventional imaging device at the time of performing correction for removal of vertical line noise using a vertical OB region which is an optically black region.

DESCRIPTION OF EMBODIMENT

[0019] Hereinafter, an embodiment for carrying out the present invention will be described with reference to the drawings.

Embodiment

[0020] FIG. 1 is a block diagram showing a configuration of an imaging device according to a present embodiment.

[0021] An output signal of a solid state image sensor **101** is amplified by an amplifier **102**, quantized by an AD converter **103**, and then input to a vertical line correction unit **104**.

[0022] The vertical line correction unit **104** includes an OB line selector **105**, a line memory **106**, a level adjuster **107**, a first selector (a selector A) **108**, a second selector (a selector B) **110**, a multiplier **111**, and three subtractors **109**, **112** and **113**.

[0023] Signals Q_n , quantized by the AD converter **103** are input to the OB line selector **105**, and of the signals Q_n , only the signals in a vertical OB line period (vertical OB line signals: X_n) are output.

[0024] A subtraction result Y_n obtained by performing an operation described later on the vertical OB line signal X_n is rewritten to the line memory **106** for each frame.

[0025] With respect to the subtraction result stored in the line memory **106**, in the case the vertical OB line signal X_n is the first vertical OB line signal in a frame, the vertical OB line signal Y_{n-1} of a past frame is emitted to the level adjuster **107**. This vertical OB line signal Y_{n-1} of a past frame is a vertical OB line signal of a past frame read out from the line memory **106** during a period of input of the first vertical OB line signal in a frame to the vertical line correction unit **104**.

[0026] On the other hand, in the case the vertical OB line signal X_n is a vertical OB line signal of a second or later line, the vertical OB line signal Y_{n-1} of a past frame is emitted to the selector A **108** without going through the level adjuster **107**.

[0027] When the vertical OB line signal Y_{n-1} of a past frame is emitted to the level adjuster **107** in the case the vertical OB line signal X_n is the first vertical OB line signal in a frame, the level adjuster **107** adjusts the level of the vertical OB line signal Y_{n-1} , according to the amplification factor of the amplifier **102**, and outputs the vertical OB line signal Y_{n-1} which has been adjusted to the selector A **108**. Additionally, level adjustment according to the amplification factor of the amplifier **102** will be described later.

[0028] In the case the vertical OB line signal X_n is the first vertical OB line signal in a frame, the selector A **108** emits the vertical OB line signal Y_{n-1} after level adjustment to the subtractor **109**, and in the case the vertical OB line signal X_n is the vertical OB line signal of a second or later line, the selector A **108** emits the vertical OB line signal Y_{n-1} of a past frame to the subtractor **109**.

[0029] The subtractor **109** receives input of the vertical OB line signal X_n from the OB line selector **105** and the vertical OB line signal Y_{n-1} from the selector A **108**, subtracts the vertical OB line signal Y_{n-1} from the vertical OB line signal X_n , and outputs the result $(X_n - Y_{n-1})$ to the multiplier **111**.

[0030] In the case the vertical OB line signal X_n is the first vertical OB line signal in a frame, the selector B **110** outputs a cyclic coefficient K_{1H} to the multiplier **111**, and in the case the vertical OB line signal X_n is the vertical OB line signal of a second or later line, the selector B **110** outputs a cyclic coefficient K to the multiplier **111**.

[0031] The multiplier **111** receives input of the subtraction result $(X_n - Y_{n-1})$ and the cyclic coefficient K_{1H} or K , and multiplies the two. That is, in the case the vertical OB line signal X_n is the first vertical OB line signal in a frame, $(X_n - Y_{n-1})$ is multiplied by the cyclic coefficient K_{1H} and $K_{1H}(X_n - Y_{n-1})$ is obtained, and in the case the vertical OB line signal X_n is the vertical OB line signal of a second or later line,

$(X_n - Y_{n-1})$ is multiplied by the cyclic coefficient K and $K(X_n - Y_{n-1})$ is obtained. Then, the multiplication result is output to the subtractor **112**.

[0032] The subtractor **112** receives input of the vertical OB line signal X_n from the OB line selector **105**, and $K_{1H}(X_n - Y_{n-1})$ or $K(X_n - Y_{n-1})$ from the multiplier **111**, subtracts $K_{1H}(X_n - Y_{n-1})$ or $K(X_n - Y_{n-1})$ from the vertical OB line signal X_n , and outputs the result to the subtractor **113** and the line memory **106** as a vertical OB line signal Y_n to be rewritten to the line memory.

[0033] The cyclic operation is repeated thereafter.

[0034] That is, with the cyclic operation described above, in the case the vertical OB line signal X_n is the first vertical OB line signal in a frame, the following Equation (1) is obtained as the vertical OB line signal Y_n to be rewritten to the line memory, and in the case the vertical OB line signal X_n is the vertical OB line signal of a second or later line, the following Equation (2) is obtained as the vertical OB line signal Y_n .

[Expression 1]

[0035]

$$Y_n = X_n - K_{1H}(X_n - Y_{n-1}) = (1 - K_{1H}) \cdot X_n + K_{1H} \cdot Y_{n-1} \quad \text{Equation (1)}$$

[Expression 2]

[0036]

$$Y_n = X_n - K(X_n - Y_{n-1}) = (1 - K) \cdot X_n + K \cdot Y_{n-1} \quad \text{Equation (2)}$$

[0037] A signal Q_n quantized by the AD converter **103** and the vertical OB line signal Y_n expressed by Equation (1) or (2) mentioned above from the subtractor **113** are input to the subtractor **113**. The subtractor **113** performs a vertical line correction operation by taking the vertical OB line signal Y_n expressed by Equation (1) or (2) mentioned above as a vertical line correction signal and subtracting the same from the quantized signal Q_n .

[0038] FIG. 2 is a diagram for describing gain adjustment performed by the level adjuster **107** according to the present embodiment.

[0039] It is assumed that the gain of the amplifier **102** changes from G_a to G_b in a blanking period between a frame **1** and a frame **2**. In this case, the video signal level of the frame **2** is G_b/G_a times with respect to the video signal level of the frame **1**.

[0040] Then, a vertical OB line signal of a past frame read out from the line memory **106** in the first line of vertical OB lines is multiplied by a gain value for level adjustment G_b/G_a , and the level is adjusted to be near the level of a current vertical OB line signal. Then, the cyclic operation of (Equation 1) is performed on the vertical OB line signal which has been adjusted, and the signal is written again to the line memory **106** as an adjusted signal Y_n .

[0041] The gain of the amplifier **102** is not changed for the same frame for the second or later line of the vertical OB lines, and signal adjustment is not necessary. Accordingly, the gain value for level adjustment is returned to one for the second or later line of the vertical OB lines.

[0042] By the operation described above, the level of the signal Y_n stored in the line memory **106** and the level of the vertical OB line signal will be approximately similar for the frame **1** and the frame **2** regardless of the gain, and the vertical line correction described above is enabled.

[0043] FIG. 3 is a flow chart of signal processing according to the present embodiment, and each step described below forms an imaging method of the present invention.

[0044] First, to generate a vertical line correction signal, a vertical OB line signal Y_{n-1} stored in the line memory **106** in a past frame is read out (**S301**). Next, whether a quantized signal input from the solid state image sensor **101** via the amplifier **102** and the AD converter **103** is of the first line of vertical OB or not is determined (**S302**).

[0045] If the signal is of the first line of vertical OB (**S302: Yes**), level adjustment for the signal Y_{n-1} read out in **S301** is performed. Specifically, replacement by $[Y_{n-1} \times G_b/G_a]$ as the new Y_{n-1} is performed (**S303**). Additionally, in the case the quantized signal mentioned above is not of the first line of vertical OB (**S302: No**), it is of the second or later line of the vertical OB, and the Y_{n-1} is left unchanged.

[0046] Next, the Y_{n-1} is subtracted from a signal X_n of the current vertical OB line (**S304**).

[0047] Furthermore, whether the current signal is of the first line of the vertical OB or not is determined (**S305**), and if the signal is of the first line of the vertical OB (**S305: Yes**), multiplication by the cyclic coefficient K_{1H} is performed, and $K_{1H}(X_n - Y_{n-1})$ is calculated (**S306**).

[0048] On the other hand, if the signal is of the second or later line of the vertical OB (**S305: No**), multiplication by the cyclic coefficient K is performed, and $K(X_n - Y_{n-1})$ is calculated (**S307**).

[0049] Then, the Y_n given by Equation 1 or 2 mentioned above is calculated using the value obtained in **S306** or **S307** (**S308**), and this is stored in the line memory **106** again (**S309**).

[0050] Whether or not the vertical OB lines are over is determined (**S310**), and if they are not over (**S310: No**), the steps are repeated from **S301**. On the other hand, in the case the vertical OB lines are over (**S310: Yes**), the signal stored in the line memory **106** is read out as the vertical line correction signal and is subtracted from an effective pixel to thereby perform vertical line correction (**S311**).

[0051] In this manner, by causing the level of a vertical line correction signal to follow the video level change, vertical line correction with small correction residue is performed.

[0052] In the process described above, grasping of whether a current signal is of the first line or the second or later line in the vertical OB region or whether it is of an effective pixel region may be performed using an interrupt process, for example.

[0053] Additionally, in the embodiment described above, the change in the gain is described as the change in the amplification factor of the amplifier before AD conversion, but the gain may also be changed by performing multiplication on a quantized signal after AD conversion. Such a mode after change is also included within the scope of the present invention. Also, with respect to gain adjustment for the first line of vertical OB, multiplication by G_b/G_a is not restrictive, and adjustment by addition of another factor separately determined is also possible. Also, an operation of adjusting the level by reading out a signal stored in the line memory **106** as the vertical line correction signal, subtracting the same from an effective pixel, and then adding or subtracting a certain value, or an operation of adjusting the level by adding or subtracting a certain value to or from a signal read out from the line memory **106** and then subtracting the same by the subtractor **113** is easily conceivable.

[0054] Heretofore, the imaging device and the imaging method of the present invention have been described using an embodiment, but it is apparent that each step forming the imaging method described above may be executed according to a program recording the step and by using a computer.

INDUSTRIAL APPLICABILITY

[0055] According to the present invention, by causing the level of a vertical line correction signal to follow the video level change such as a change in the amplification factor, vertical line correction may be performed while reducing the correction residue.

REFERENCE SIGNS LIST

- [0056] 101, 1001 Solid state image sensor
- [0057] 102, 1002 Amplifier
- [0058] 103, 1003 AD converter
- [0059] 104, 1004 Vertical line correction unit
- [0060] 105, 1005 OB line selector
- [0061] 106, 1006 Line memory
- [0062] 107 Level adjuster
- [0063] 108 Selector A
- [0064] 109, 112, 113, 1008 Subtractor
- [0065] 110 Selector B
- [0066] 111 Multiplier
- [0067] 1007 Line integrator

1. An imaging device comprising:
 - a solid state image sensor including an optical black region; and
 - a vertical line correction unit for performing vertical line correction on an output signal of the solid state image sensor, wherein the vertical line correction unit includes an OB line selector for selecting an optical black line signal included in output signals of the solid state image sensor, a memory for storing the optical black line signal, a level adjuster for adjusting a level of an optical black line signal of a past frame read out from the memory, according to a video gain of the output signal of the solid state image sensor, a first subtractor for calculating a difference signal between a first optical black line signal of a current frame and the optical black line signal of the past frame whose level has been adjusted, a multiplier for calculating a product by multiplying the difference signal by a cyclic coefficient, a second subtractor for obtaining a signal which is the optical black line signal of the current frame from which the product of the difference signal and the cyclic coefficient has been subtracted, and rewriting the signal after subtraction to the memory as an optical black line signal, and

- a third subtractor for subtracting a signal read out from the memory from an output signal from an effective pixel region of the solid state image sensor.
- 2. An imaging method of performing vertical line correction on an output signal of a solid state image sensor including an optical black region, the method comprising:
 - a step of selecting an optical black line signal included in output signals of the solid state image sensor;
 - a step of storing the optical black line signal in a memory;
 - a step of reading an optical black line signal of a past frame from the memory, and adjusting a level according to a video gain of the output signal of the solid state image sensor;
 - a first subtracting step of calculating a difference signal between a first optical black line signal of a current frame and the optical black line signal of the past frame whose level has been adjusted;
 - a step of calculating a product by multiplying the difference signal by a cyclic coefficient;
 - a second subtracting step of obtaining a signal which is the optical black line signal of the current frame from which the product of the difference signal and the cyclic coefficient has been subtracted, and rewriting the signal after subtraction to the memory as an optical black line signal; and
 - a third subtracting step of subtracting a signal read out from the memory from an output signal from an effective pixel region of the solid state image sensor.
- 3. A program for performing vertical line correction on an output signal of a solid state image sensor including an optical black region, the program being for causing a computer to execute the following steps:
 - a step of selecting an optical black line signal included in output signals of the solid state image sensor;
 - a step of storing the optical black line signal in a memory;
 - a step of reading an optical black line signal of a past frame from the memory, and adjusting a level according to a video gain of the output signal of the solid state image sensor;
 - a first subtracting step of calculating a difference signal between a first optical black line signal of a current frame and the optical black line signal of the past frame whose level has been adjusted;
 - a step of calculating a product by multiplying the difference signal by a cyclic coefficient;
 - a second subtracting step of obtaining a signal which is the optical black line signal of the current frame from which the product of the difference signal and the cyclic coefficient has been subtracted, and rewriting the signal after subtraction to the memory as an optical black line signal; and
 - a third subtracting step of subtracting a signal read out from the memory from an output signal from an effective pixel region of the solid state image sensor.

* * * * *