

No. 891,482.

PATENTED JUNE 23, 1908.

W. LANGENHEIM.
LUBRICATOR FOR MAIN BEARINGS OF CENTRIFUGAL BREAKERS.
APPLICATION FILED MAR. 17, 1908.

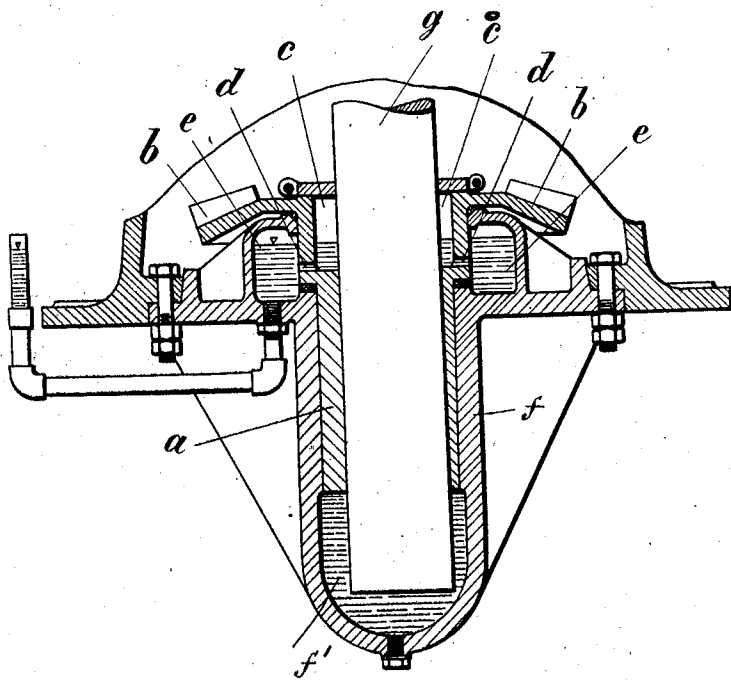

Witnesses:
H. B. Schuly
August Miller

Inventor:
Wilhelm Langenheim
by his attorney
Frank B. Smith.

UNITED STATES PATENT OFFICE.

WILHELM LANGENHEIM, OF DUISBURG, GERMANY.

LUBRICATOR FOR MAIN BEARINGS OF CENTRIFUGAL BREAKERS.

No. 891,482.

Specification of Letters Patent.

Patented June 23, 1908.

Application filed March 17, 1908. Serial No. 421,610.

To all whom it may concern:

Be it known that I, WILHELM LANGENHEIM, a subject of the German Emperor, residing at Duisburg, Germany, have invented new and useful Improvements in Lubricators for the Main Bearings of Centrifugal Breakers, of which the following is a specification.

This invention relates to an improved lubricator for the foot bearings of centrifugal breakers, by means of which a continuous flow of the lubricant along the surfaces to be lubricated is insured.

The accompanying drawing represents a vertical central section of a lubricator embodying my invention. A stationary main bearing *f*, is provided with a lower oil reservoir *f'*, and an upper oil reservoir *e*. Within bearing *f*, is rotatably mounted a sleeve *a*, provided with an upper oil reservoir *c*, which communicates through port *d*, with reservoir *e*. Sleeve *a*, has an integral miter wheel *b*, by means of which the sleeve receives rotary motion. Sleeve *a*, is eccentrically bored for the accommodation of shaft *g*, which is rotated independently from sleeve *a*, in suitable manner, and which projects for a considerable distance below sleeve *a*, into reservoir *f'*.

During the operation of the breaker, shaft *g*, rotates eccentrically in rotating sleeve *a*. In this way the lower end of shaft *g*, will turn

in reservoir *f'*, in such manner, that each point of the axis of the shaft describes a circle around the axis of the reservoir. As this movement of shaft *g*, takes place with great rapidity, the oil is forced, by centrifugal action, against the wall of casing *f'*. Owing to the pressure thus exerted upon the outer strata of the oil, the latter will climb up between bearing *f*, and rotating sleeve *a*. At the same time a corresponding suction is produced within reservoir *f'*, at the periphery of shaft *g*, so that the oil contained in upper reservoirs *e*, *c*, will be caused to flow down between shaft *g*, and sleeve *a*, into reservoir *f'*, thus completing the cycle.

I claim:

A device of the character described, comprising a stationary bearing having a lower oil reservoir and an upper oil reservoir, a sleeve rotatably mounted in said bearing and having an upper oil chamber that communicates with the upper oil reservoir, and a rotary shaft eccentrically mounted in the sleeve and projecting into the lower oil reservoir, substantially as specified.

Signed by me at Dusseldorf (Germany) this fourth day of March 1908.

WILHELM LANGENHEIM.

Witnesses:

PETER LIEBER,
WILHELM FLASCHE.