



(11) **EP 2 978 301 B1**

(12) **EUROPEAN PATENT SPECIFICATION**

(45) Date of publication and mention of the grant of the patent:
06.12.2017 Bulletin 2017/49

(21) Application number: **14712685.8**

(22) Date of filing: **27.03.2014**

(51) Int Cl.:
A01F 15/08^(2006.01) A01F 21/00^(2006.01)

(86) International application number:
PCT/EP2014/056128

(87) International publication number:
WO 2014/154790 (02.10.2014 Gazette 2014/40)

(54) **AGRICULTURAL BALER WITH AUXILIARY MOTOR**

LANDWIRTSCHAFTLICHE BALLENPRESSE MIT HILFSMOTOR

PRESSE À BALLE AGRICOLE AVEC MOTEUR AUXILIAIRE

(84) Designated Contracting States:
AL AT BE BG CH CY CZ DE DK EE ES FI FR GB GR HR HU IE IS IT LI LT LU LV MC MK MT NL NO PL PT RO RS SE SI SK SM TR

(30) Priority: **27.03.2013 BE 201300212**

(43) Date of publication of application:
03.02.2016 Bulletin 2016/05

(73) Proprietor: **CNH Industrial Belgium N.V. 8210 Zedelgem (BE)**

(72) Inventors:
• **BONTE, Xavier NL-4528 Et Sint Kruis (NL)**

- **DE RYCKE, Stefan B-9870 Olsene - Zulte (BE)**
- **DEMON, Frederik B-8310 Brugge (Sint-Kruis) (BE)**
- **VANDEVELDE, Pieter B-8200 Sint Michiels Brugge (BE)**

(74) Representative: **CNH Industrial IP Department Patent Department, Leon Claeyssstraat 3A 8210 Zedelgem (BE)**

(56) References cited:
EP-A1- 1 974 601 EP-A1- 2 193 707 DE-A1- 10 145 407

EP 2 978 301 B1

Note: Within nine months of the publication of the mention of the grant of the European patent in the European Patent Bulletin, any person may give notice to the European Patent Office of opposition to that patent, in accordance with the Implementing Regulations. Notice of opposition shall not be deemed to have been filed until the opposition fee has been paid. (Art. 99(1) European Patent Convention).

Description**Field of the invention**

[0001] The invention relates to the field of agricultural balers for producing bales of compressed agricultural crop material. More specifically, the present invention relates to balers with an auxiliary motor connectable to the flywheel.

Background of the invention

[0002] The vast majority of balers does not have its own engine, but is towed by a tractor, and is powered by coupling the power take-off (PTO) shaft of the tractor to an input shaft of the baler. The baler further has a flywheel connected to the input shaft, and a gearbox that drives the various mechanisms in the baler to pick-up the crop from a field, to form the crop into bales and to wrap twine and/or foil around the bales.

[0003] A one-way clutch is typically arranged between the PTO shaft and the flywheel to allow the flywheel to rotate faster than the PTO shaft. The baler input shaft can be operatively decoupled from the tractor PTO, e.g. for transportation of the baler from one field to the other.

[0004] A large and heavy flywheel is typically required in a baler, especially in so called "large square balers", or "high density balers" to overcome peak loads encountered by the baler gearbox, which occurs e.g. when the plunger of the baler compresses the crop material in the bale chamber when forming the bales. By using a flywheel with a high inertia and running at a high speed (e.g. 1000 rpm), peak energy for the peak loads can be delivered by the flywheel. During the compression the flywheel slightly slows down, but is accelerated again by the tractor PTO between two compressions.

[0005] A problem of a heavy flywheel is that it becomes more difficult to start-up such a baler, because of the high inertia of the flywheel. EP1974601 addresses this problem by disclosing a large-bale baling press with a starting arrangement having an auxiliary drive, which assists in a first phase of starting up the large-bale baling press, until the main drive accelerates to a higher speed than the auxiliary drive.

[0006] Another problem of a heavy flywheel is that it becomes more difficult to manually rotate the flywheel during maintenance. This problem is addressed in EP2193707, where a baler is described with an auxiliary motor configured to operate components of the baler in a slow manner for adjustment or maintenance. The motor may be operated in forward or reverse mode.

[0007] Another problem of the high inertia is that it takes more time to switch off the baler. This problem is not addressed in the art. Instead, one just waits until the baler finally comes to a stop, but until that moment, approaching the baler is dangerous, as one might get caught by the moving mechanisms.

[0008] While recognizing the benefits of a baler with

an auxiliary motor for the above mentioned purposes, the mounting arrangement thereof can be improved.

Summary of the invention

[0009] It is an object of embodiments of the present invention to provide a baler with a good mounting of an auxiliary motor.

[0010] It is also an object of embodiments of the present invention to provide a baler flywheel assembly, and a baler gearbox assembly especially adapted for a good mounting of an auxiliary motor.

[0011] The above objective is accomplished by a device according to the present invention as defined by claim 1. In a further aspect, the present invention provides an agricultural baler comprising a shaft for coupling with a power take-off, a flywheel connected to the shaft, and an auxiliary motor connectable to the flywheel. The baler further comprises a disc brake system comprising a brake disc adapted for braking the flywheel and having a toothed rim, the auxiliary motor being engageable to the toothed rim of the brake disc.

[0012] An advantage of this flywheel and disk brake arrangement is that it may be used for several purposes: 1) for keeping the flywheel in a fixed position, e.g. during transport, 2) for actively slowing down the flywheel when the baler is switched off, which is considerably faster and enhances the users safety, 3) for engagement with an auxiliary motor, thanks to the toothed rim of the brake disc. All these functions are related to a single brake disc with a toothed rim, thus saving material, weight and cost.

[0013] In embodiments of the agricultural baler, the toothed rim of the brake disc is a toothed outer rim.

[0014] The brake disc may have a toothed inner rim, or a toothed outer rim for engaging the auxiliary motor. A toothed outer rim has the advantage that it may be easier to removably mount the auxiliary motor thereto, and that it is easier to produce.

[0015] In embodiments of the agricultural baler, the auxiliary motor is adapted for helping to accelerate the flywheel during baler start-up.

[0016] In this embodiment, the motor should be able to drive the flywheel in forward direction so as to provide extra torque. In this embodiment, the motor is preferably a motor having a power of at least 1.0 kWatt (e.g. from 1.0 kWatt to 20 kWatt). In this way, the risk of a start-up failure of the baler is reduced or eliminated.

[0017] In embodiments of the agricultural baler, the auxiliary motor is adapted for rotating the flywheel backward.

[0018] Such an auxiliary motor may be a low power motor (e.g. less than 1.0 kWatt such as e.g. from 0.1 to 1.0 kWatt) adapted for reversing the flywheel at a low speed (e.g. less than 10 rpm such as e.g. from 1 to 10 rpm). Such an auxiliary motor may be able to drive the flywheel in backward direction or in both directions to assist an operator during maintenance work.

[0019] In embodiments of the agricultural baler, the

brake disc is mounted on the flywheel.

[0020] Mounting the brake disc directly to the flywheel may decrease stresses and wear of the shaft, and increase heat transfer during braking. It may also result in a more robust and compact design.

[0021] In embodiments of the agricultural baler, the centre of mass of the brake disc substantially coincides with the centre of mass of the flywheel.

[0022] In this way, the flywheel and brake disc are better balanced, which further reduces stresses and wear of the shaft.

[0023] In embodiments of the agricultural baler, the baler further comprises a gearbox and the disc brake system further comprises at least one brake caliper, and the brake caliper is mounted to the gearbox.

[0024] The gearbox is a very rigid part of the baler, and is typically located close to the flywheel. By mounting the caliper on the gearbox, tolerances can be kept under control, rigid mounting of the caliper is obtained, and stresses during braking can be directly transferred to the gearbox.

[0025] In embodiments of the agricultural baler, the baler further comprises a handle connected to the at least one brake caliper via a cable.

[0026] In this way, the disc brake can be activated manually, e.g. as an emergency brake. When the handle has the form of a handbrake lever, it can also hold the flywheel in a steady state, e.g. during transport.

[0027] In embodiments of the agricultural baler, the at least one brake caliper is a hydraulic caliper, and the baler further comprises a hydraulic circuit fluidly connected to the brake caliper, and a baler controller for activating and deactivating the hydraulic brake caliper.

[0028] The baler controller may comprise a separate or integrated brake controller. The invention provides a baler flywheel assembly comprising a flywheel and a brake disc adapted for breaking the flywheel, the brake disc having a toothed rim.

[0029] This flywheel assembly is an integrated part of one of the embodiments of the baler according to the invention. The brake disc may be mounted directly to the flywheel, or indirectly by being mounted on a same axis.

[0030] In a further aspect, the invention also provides a baler gearbox assembly, comprising a baler gearbox; a baler flywheel assembly according to the invention, mounted to the baler gearbox; and a brake caliper mounted to the baler gearbox for engaging with the brake disc of the baler flywheel assembly.

[0031] This gearbox assembly is a further integrated part of one of the embodiments of the baler according to the present invention.

[0032] In a further aspect, the invention also provides a tractor and baler combination, comprising an agricultural baler according to the invention; a tractor having a PTO connectable to the shaft of the baler for accelerating the flywheel of the baler; wherein the tractor further comprises a tractor controller circuit for sending a command to the baler controller for selectively activating the disc

brake system and/or the auxiliary motor.

[0033] This allows commands for starting, reversing or stopping the flywheel to be sent from the cabine of the tractor, without having to step next to the baler. This is faster, safer, and more convenient.

[0034] Particular and preferred aspects of the invention are set out in the accompanying independent and dependent claims. These and other aspects of the invention will be apparent from and elucidated with reference to the embodiment(s) described hereinafter.

Brief description of the drawings

[0035] The invention will be further elucidated by means of the following figures.

FIG. 1 is a side view of a classical tractor and a towable baler according to the prior art.

FIG. 2 shows a baler with a flywheel and an auxiliary motor, known in the art.

FIG. 3 shows another baler with a flywheel and auxiliary motor, known in the art.

FIG. 4 is a schematic drawing in side view of a flywheel and disc brake and auxiliary motor arrangement according to an embodiment of the present invention.

FIG. 5 is a front view (direction V) of the schematic drawing of FIG. 4, further showing the position of a gear wheel and a brake pad according to an embodiment of the present invention.

FIG. 6 is a schematic drawing in side view of another flywheel and disc brake and auxiliary motor arrangement according to an embodiment of the present invention.

FIG. 7 is a schematic drawing of an embodiment of a flywheel and brake disc assembly shaped and arranged for having coinciding centers of mass according to an embodiment of the present invention.

FIG. 8 is a schematic drawing of a system comprising a tractor (right) and a baler (left), the baler comprising the flywheel and disc brake and auxiliary motor arrangement of FIG. 6.

FIG. 9 is an enlarged view of part of the baler of FIG. 1, wherein the crank is in an unfavorable position 'U' for start-up, as also disclosed in co-pending patent application PCT/EP2014/053067 of the applicant and which is useful for understanding the present invention.

FIG. 10 is an enlarged view of part of the baler of FIG. 1, wherein the crank is in a favorable position 'C' for start-up, as also disclosed in co-pending patent application PCT/EP2014/053067 of the applicant and which is useful for understanding the present invention.

FIG. 11 shows an example of the rotational speed and corresponding kinetic energy of a flywheel of an empty baler at start-up, as also disclosed in co-pending patent application PCT/EP2014/053067 of the

applicant and which is useful for understanding the present invention.

FIG. 12 shows a processing system according to embodiments of the present invention.

[0036] The drawings are only schematic and are non-limiting. In the drawings, the size of some of the elements may be exaggerated and not drawn on scale for illustrative purposes. Any reference signs in the claims shall not be construed as limiting the scope.

[0037] In the different drawings, the same reference signs refer to the same or analogous elements.

Detailed description of illustrative embodiments

[0038] The present invention will be described with respect to particular embodiments and with reference to certain drawings but the invention is not limited thereto but only by the claims. The drawings described are only schematic and are non-limiting. In the drawings, the size of some of the elements may be exaggerated and not drawn on scale for illustrative purposes. The dimensions and the relative dimensions do not correspond to actual reductions to practice of the invention.

[0039] Furthermore, the terms first, second and the like in the description and in the claims, are used for distinguishing between similar elements and not necessarily for describing a sequence, either temporally, spatially, in ranking or in any other manner. It is to be understood that the terms so used are interchangeable under appropriate circumstances and that the embodiments of the invention described herein are capable of operation in other sequences than described or illustrated herein.

[0040] Moreover, the terms top, under and the like in the description and the claims are used for descriptive purposes and not necessarily for describing relative positions. It is to be understood that the terms so used are interchangeable under appropriate circumstances and that the embodiments of the invention described herein are capable of operation in other orientations than described or illustrated herein.

[0041] It is to be noticed that the term "comprising", used in the claims, should not be interpreted as being restricted to the means listed thereafter; it does not exclude other elements or steps. It is thus to be interpreted as specifying the presence of the stated features, integers, steps or components as referred to, but does not preclude the presence or addition of one or more other features, integers, steps or components, or groups thereof. Thus, the scope of the expression "a device comprising means A and B" should not be limited to devices consisting only of components A and B. It means that with respect to the present invention, the only relevant components of the device are A and B.

[0042] Reference throughout this specification to "one embodiment" or "an embodiment" means that a particular feature, structure or characteristic described in connection with the embodiment is included in at least one em-

bodiment of the present invention. Thus, appearances of the phrases "in one embodiment" or "in an embodiment" in various places throughout this specification are not necessarily all referring to the same embodiment, but may. Furthermore, the particular features, structures or characteristics may be combined in any suitable manner, as would be apparent to one of ordinary skill in the art from this disclosure, in one or more embodiments.

[0043] Similarly it should be appreciated that in the description of exemplary embodiments of the invention, various features of the invention are sometimes grouped together in a single embodiment, figure, or description thereof for the purpose of streamlining the disclosure and aiding in the understanding of one or more of the various inventive aspects. This method of disclosure, however, is not to be interpreted as reflecting an intention that the claimed invention requires more features than are expressly recited in each claim. Rather, as the following claims reflect, inventive aspects lie in less than all features of a single foregoing disclosed embodiment. Furthermore, while some embodiments described herein include some but not other features included in other embodiments, combinations of features of different embodiments are meant to be within the scope of the invention, and form different embodiments, as would be understood by those in the art. In the description provided herein, numerous specific details are set forth. However, it is understood that embodiments of the invention may be practiced without these specific details. In other instances, well-known methods, structures and techniques have not been shown in detail in order not to obscure an understanding of this description.

[0044] Where in embodiments of the present invention reference is made to a "rectangular baler" reference is made to an agricultural baler for making cuboid bales (known as "rectangular bales").

[0045] Where in embodiments of the present invention reference is made to "high density bales", bales with a density higher than 100 kg/m³, for example higher than 190 kg/m³ are meant.

[0046] In the present invention, "centre of gravity" and "centre of mass" are used as synonyms.

[0047] Where in embodiments of the present invention reference is made to "disc brake system", reference is made to a device for slowing down or stopping a rotating wheel. In this application reference is made to the caliper-type of disc brakes, comprising a brake disc and a caliper, the brake caliper comprising two brake pads, to be forced to both sides of the disc.

[0048] Where in embodiments of the present invention reference is made to "brake disc", reference is made to the actual disc being part of the disc brake system.

[0049] Where in embodiments of the present invention reference is made to "normal direction" or "forward direction" of the input shaft or of the flywheel or of the crank of the baler, the rotation direction of the input shaft or of the flywheel or of the crank during normal production of bales is referred to.

[0050] Where in embodiments of the present invention reference is made to "normal operation of the baler", the condition of the baler is meant wherein the flywheel is rotated for producing bales.

[0051] Where in embodiments of the present invention reference is made to "reverse direction" or "backward direction" of the input shaft or the flywheel or the crank of the baler, the rotation direction opposite to the normal direction is referred to.

[0052] Agricultural balers of the type that can be towed and powered via a tractor PTO are known in the art. Referring to the drawings, FIG. 1 shows an example of an agricultural baler 70 comprising a frame 25 which is equipped with a forwardly extending tongue 26 at its front end with hitch means (not shown) for coupling the baler 70 to a towing tractor 17. A pick-up assembly 27 lifts windrowed crop material off the field as the baler 70 is travelled thereover, e.g. while being pulled by a tractor 17, and delivers such material into the front end of a rearwardly and upwardly curved, charge-forming feeder duct 28. The duct 28 communicates at its upper end with an overhead, fore-and-aft extending bale chamber 80 into which crop charges are loaded by a cyclically operating stuffer mechanism 29. A continuously operating packer mechanism 24 at the lower front end of the feeder duct 28 continuously feeds and packs material into the duct 28 so as to cause charges of the crop material to take on and assume the internal configuration of the duct 28 prior to periodic engagement by the stuffer mechanism 29 and insertion up into the bale chamber 80. The packer mechanism 24 may be replaced by a rotor mechanism which will also continuously feed and pack material into the duct 28. The feeder duct 28 may be equipped with means (not illustrated) for establishing whether a complete charge has been formed therein and operating the stuffer mechanism 29 in response thereto. Each action of the stuffer mechanism 29 introduces a "charge" or "flake" of crop material from the duct 28 into the chamber 80.

[0053] A plunger 13 reciprocates in a fore-and-aft direction within the bale chamber 80, at least within a first part thereof. Biomass fed via the feeder duct 28 is thereby compacted, e.g. compressed or otherwise treated, so as to form bales in the above-described operation of the agricultural baler 70. Cuboid shaped bales, also known as "rectangular bales" are formed. The formed bales may then be moved forward by the reciprocating motion of the plunger 13 to shift serially and incrementally along the bale chamber 80 towards a discharge outlet, wherefrom the bales may eventually be ejected. The baler 70 may furthermore comprise components such as a knotter mechanism for automatically tying the completed bales 16 with e.g. twine or similar lineal object to make them self-supporting, for example for shipping and storage. Once tied, the bales are discharged from the discharge outlet of the bale chamber 80 onto a discharge 31 in the form of a chute, for gently lowering the bales near ground level.

[0054] Large balers 70, especially rectangular balers 70 for producing high-density bales typically have a flywheel 2 with a relatively large diameter (e.g. in the range of 75 to 130 cm, e.g. 110 cm) and heavy weight (e.g. in the range of 300 to 1000 kg, e.g. 700 kg) for obtaining a high inertial mass or energy equivalent. When all crop material of one field is compacted into bales, the baler 70 is temporarily stopped, e.g. by decoupling or disabling the tractor PTO 15. While running freely, the flywheel 2 will gradually slow down until it stops, and the related functions, such as the pick-up, packer or stuffer mechanism are deactivated along with the flywheel 2. The baler 70 is then brought to another field, usually while there is still some crop material left in the bale chamber 80. When arriving at the next field to be harvested, the baler 70 needs to be started up again, but it has been found, particularly with large balers 70 having a large and heavy flywheel 2, that problems may arise due to the high inertia of the flywheel 2, especially when there is still crop material left in the bale chamber 80, which is almost always the case, since balers 70 are not emptied between different fields. The start-up problems may be solved by using an auxiliary motor 5, which needs to be operatively connectable to the flywheel 2.

[0055] FIG. 2 shows part of a prior art agricultural baler with a flywheel 2 having a toothed outer rim 156, and an auxiliary motor 5 arranged thereto via a gearwheel 57. However, providing a toothed outer rim on a large and heavy flywheel becomes extremely difficult and expensive, and it would be very difficult to keep tolerances under control.

[0056] FIG. 3 shows another prior art agricultural baler 70, with an auxiliary motor 5 as part of a startup device 207, arranged between the input shaft 3 of the baler 70 and the flywheel 2. This arrangement requires several extra components, occupies extra space, and complicates the shaft interconnections.

[0057] While looking for a more suitable arrangement to connect the auxiliary motor 5 to the large and heavy flywheel 2, the inventors came up with the idea of adding a disk brake system 40 to the flywheel 2, and providing the brake disc 41 with a toothed rim 59 (e.g. a toothed outer rim) for engagement with the auxiliary motor 5.

[0058] Such a baler flywheel arrangement is schematically illustrated in FIG. 4. A huge advantage of providing a disc 41 with a toothed rim 59, is that it is much easier to produce a relatively small disc 41 with a toothed rim 59, than a large and heavy flywheel 2 with a toothed outer rim. For example, the flywheel 2 may have a three-dimensional shape with an outer diameter "D" in the range of 75 to 130 cm, e.g. 110 cm, and a maximum thickness of 40 to 60 cm, e.g. 50 cm, and a weight in the range of 240 to 1000 kg, e.g. 700 kg, whereas the brake disc 41 may have a substantially planar shape, with a diameter "d" in the range of 30 to 60 cm, e.g. 45 cm, and a thickness of 25 to 35 mm, e.g. 30 mm, and a weight in the range of 20 to 40 kg, e.g. 30 kg. Such a disc 41 is much easier to handle and to machine than such a flywheel 2, and

the tolerances, especially those of the toothed rim 59 can be kept much better under control. A disc 41 with a toothed outer rim 59 is preferred to a toothed inner rim because it is easier to removably mount the auxiliary motor thereto, and because it is easier to produce.

[0059] By providing a brake disc 41 with a relatively large diameter (as compared to the diameter of the shaft), a relatively large torque can be transmitted to the shaft 3 by the auxiliary motor 5. It is to be noted that the diameter "d" of the disc 41 can be selected independent of the diameter "D" of the flywheel 2, so that the dimensions of the flywheel 2 and those of the disc 41 can be optimized separately. The same applies to their thickness.

[0060] In addition, by adding a brake caliper 51, which is a relatively small component, and by machining part of the side surface of a disc 41, which is an inexpensive extra machining step since the disc 41 is machined already for providing the toothed rim 59, the disc 41 becomes a brake disc 41, and hence disc brake functionality is added to the flywheel 2 with a minimum of extra components, and by sharing the same disc 41 with toothed rim 59 as can be used for start-up.

[0061] An advantage of this flywheel and disk brake system arrangement is that it may be used for several purposes:

- 1) for keeping the flywheel 2 in a fixed position (for preventing rotation thereof), e.g. during transport. In the prior art, this function is typically performed by using a belt which can be tensioned around a section of the flywheel;
- 2) for actively slowing down the flywheel 2 when the baler 70 is switched off. This offers the advantage that the switch-off of the baler is considerably faster and use of the baler is considerably safer. Optionally the crank arm 6 is thereby positioned in a suitable launch-position as disclosed in co-pending patent application PCT/EP2014/053067 of the applicant, which will be described further in relation to FIG. 9 to FIG. 11 and represent background art which is useful for understanding the invention;
- 3) for engagement with an auxiliary motor 5, thanks to the toothed rim 59 (e.g. a toothed outer rim) of the brake disc 41. The auxiliary motor 5 may e.g. be adapted for slowly forwarding or reversing the flywheel 2 during maintenance or repair, or may e.g. be adapted for providing extra torque during baler start-up, or any combination hereof.

[0062] All these functions are related to a single brake disc 41 with a toothed rim 59, thus saving material, weight and cost.

[0063] It should be stressed that the figures 4 to 8 are only schematic drawings, they are not drawn to the scale, but only show the principles of the invention. For example, the flywheel 2 and the parts of the disc brake system 40 as shown have a very simple shape for illustrative purposes, so as not to obscure their relation with the other

elements shown in the figure. The same applies for the number of teeth and/or the shape of the toothed outer rim 59 of the brake disc 41 and that of the gear wheel 57 in FIG. 5, which are only shown for illustrative purposes.

5 The design of toothed gear wheels is known in the art, and need not be described in further detail in this application.

[0064] Several embodiments are described next. In FIG. 4 the brake disc 41 is mounted on the shaft 3, and is thus mounted to the flywheel 2 indirectly, whereas in the embodiments of FIG. 6 and FIG. 7, the brake disc 41 is mounted to the flywheel 2 directly. The brake disc 41 may be connected to the flywheel 2 by removable fastening means (not shown), such as e.g. screws. The brake disc 41 has a toothed outer rim 59, as can be seen from FIG. 5 which is a view from angle V in FIG. 4. The toothed outer rim 59 is provided for engaging with an auxiliary motor 5, e.g. via a gear wheel 57. The auxiliary motor 5 may be e.g. an electric motor or a hydraulic motor, or a pneumatic motor. The motor 5 may be connected to the brake disc 41, or may be manually or automatically connectable to and removable from the disc brake 41, e.g. in an embodiment where the auxiliary motor 5 is adapted for delivering extra power for assisting start-up of the flywheel 2, and is thereafter removed therefrom. The brake disc 41 is preferably made of steel or cast iron. The brake disc 41 may have holes drilled through them, for heat dissipation purposes. The brake caliper 51 may be a floating caliper (having a single piston), but is preferably a fixed caliper, for avoiding sticking failures.

[0065] In embodiments, the disc brake system 40 comprises the brake disc 41 described above, and a brake caliper 51, having a pair of brake claws 42, each having a brake pad 58 made of a high friction material for contacting the side surface of the brake disc 41 when the disc brake system 40 is activated. Caliper-type disc brake systems 40 (but not comprising toothed rims) are well known in the field of automobiles and railway, and therefore need not be described in further detail here. The disc brake system 40 may be activated in any known way, e.g. mechanically, hydraulically, pneumatically or electromagnetically. In an embodiment the disc brake is activated manually by means of a handbrake lever. Caliper-type disc brake system 40 have the advantage (e.g. over drum brakes) that the braking force can be better controlled, because the braking force is proportional to the pressure placed on the brake pad 58 by the braking system, e.g. via a brake servo, braking pedal or lever, and a caliper-type disc brake cannot block because of lack of self-assist.

[0066] FIG. 6 shows a variant of the flywheel arrangement of FIG. 4, wherein the brake disc 41 is connected directly to the flywheel 2, e.g. by means of screws (not shown). An advantage of mounting the brake disc 41 directly to the flywheel 2 is that the forces applied to the brake disc 41, during acceleration of the flywheel 2 (e.g. at baler start-up), and during deceleration of the flywheel 2 (e.g. when braking) are directly transferred from the

disc 41 to the flywheel 2, instead of via the shaft 3. This prevents a large torque to be applied over the shaft portion between the flywheel 2 and the brake disc 41. Another advantage is that heat transfer (during braking) is increased, thanks to the larger contact area with the flywheel 2, closer to the braking surface as compared to direct mounting of the brake disc 41 to the shaft 3. It is to be noted that in the embodiment shown, the center of mass c1 of the flywheel 2 and the center of mass c2 of the brake disc 41 do not coincide.

[0067] FIG. 7 shows another variant of the flywheel arrangement of FIG. 6, wherein the flywheel 2 is shaped such that the centre of mass c1 of the flywheel 2, and the centre of mass c2 of the brake disc 41 coincide. The main advantage hereof is that during acceleration or deceleration of the flywheel 2 by means of the disc brake 41, the forces exerted upon the shaft 3 are largely reduced. This also reduces stresses exerted upon other components connected to the shaft, such as e.g. the shaft bearings (not shown).

[0068] FIG. 8 is a schematic drawing of an example of a system comprising a tractor (right) and a baler (left), the baler 70 comprising any of the flywheel arrangements described above. In fact, the system embodiment of FIG. 8 combines several technical features, which may also be implemented separately, or combined differently.

[0069] Common to all embodiments shown in FIG. 4 to FIG. 8 is the brake disc 41 having a toothed rim 59 (e.g. toothed outer rim), and a smooth, e.g. machined side portion (not shown) adapted for contacting brake pads 58, and an auxiliary motor 5 with a gearwheel 57 for engaging the toothed rim 59. The brake caliper 51 is preferably mounted to a gearbox 34, which is a rigid part, typically located close to the flywheel 2, but other suitable parts of the baler frame 25 may also be used for mounting the brake caliper 51.

[0070] The brake caliper 51 in the embodiment of FIG. 8 is a hydraulic caliper operationally coupled to the hydraulic system 49 of the baler 70 via hydraulic lines 54a and a first control valve 53a. The brake caliper 51, may comprise two or more pistons, also called 'pots'. The control valve 53a is controlled via a baler controller 56 comprising a brake controller (not shown) and a motor controller (not shown), either as separate controllers or as a single integrated controller. The baler controller 56 may e.g. be an electronic controller adapted for activating or deactivating the brake caliper 51 with a predetermined braking force, corresponding to a brake command given by any of the input devices 43, 44, 48, 45. In an embodiment, the baler 70 has a sensor 43a for detecting if a door or panel (not shown) is opened, and for sending a signal to the baler controller 56 for activating the disc brake system 40 for stopping and/or holding the flywheel 2 in a fixed position as long as the door or panel is open. In the same, a further or another embodiment, the baler controller 56 may be connected to a tractor controller, which may send a command from a tractor input device 45, e.g. a handle or a button, for activating the disc brake

system 40. In the same, a further or another embodiment, the baler 70 may have a local input device 44a, e.g. a handle, a button, a pedal or another input device, connected to the baler controller 56, for activating the disc brake system 40. In the same, a further or another embodiment, the baler 70 may have an emergency input device 48, e.g. an emergency button or emergency foot pedal connected to the baler controller 56, e.g. for activating the disc brake system 40 in such a way that the flywheel 2 is stopped as soon as possible (e.g. by exerting the maximum possible braking force).

[0071] The baler 70 further comprises an auxiliary motor 5, which may be arranged for slowly rotating the flywheel 2 in forward or reverse direction, e.g. for maintenance or repair purposes. The auxiliary motor 5 may also be arranged for providing extra power, besides the power delivered by the tractor PTO shaft 15, during start-up of the baler 70, e.g. during a first phase of the start-up, until the flywheel 2 has reached a predetermined angular velocity. During a second phase, the auxiliary motor 5 may or may not disengage from the brake disc 41. The auxiliary motor 5 in FIG. 8 is a hydraulic motor, but another motor could also be used, e.g. an electric or pneumatic motor (not shown). The motor 5 shown in the embodiment of FIG. 8 is operationally coupled to the hydraulic system 49 of the baler 70 via hydraulic lines 54b and a second control valve 53b. The second control valve 53b is controlled via a baler controller 56 comprising a motor controller. The motor controller could also be a separate controller. The motor controller may e.g. be an electronic controller adapted for activating or deactivating the auxiliary motor 5, in ways known in the art. The baler 70 may have an input device 44b, e.g. a button for rotating the motor 5 slowly backwards (i.e. in reverse direction R), or a button for rotating the motor 5 slowly forwards (i.e. the normal direction F), or a button for accelerating the flywheel 2 in a first phase of baler start-up. There may also be a handle (or other mechanism) for engaging or disengaging the auxiliary motor 5 from the brake disc 41. When the motor controller 56 is connected to a tractor controller 14, the command for starting the motor 5 for accelerating the flywheel 2 at baler start-up may also be given by the tractor controller 14.

[0072] The inventors have found that the start-up problem of the baler 70 occurs when the flywheel 2 does not "survive" the first plunger impact, i.e. when the plunger 13 stalls during the first compression of the crop material in the bale chamber 80, shortly after start-up. An example of such a start-up position is illustrated in FIG. 9 showing the initial condition of the crank 6 and plunger 13 just before the baler 70 is started. In the example of FIG. 9, the crank 6 is located at an angular distance θ_1 of approximately 45° with respect to the position which the crank 6 would assume when the plunger 13 is in its distal position 8 inside the bale chamber 80. When the baler 70 is started from this initial condition of the crank 6 and plunger 13, the flywheel 2 cannot gain sufficient speed before the plunger 13 impacts or reaches the crop ma-

terial 18, e.g. straw in the bale chamber 80, and the tractor engine stalls or the safety mechanism declutches the PTO 15 from the tractor engine, resulting in a start-up failure of the baler 70.

[0073] During the tests, the inventors also noted that, when switching-off the baler 70, and letting it slow-down freely, the flywheel 2 and crank 6 tended to automatically rotate to an unfavorable condition, e.g. close to crank position A or U in FIG. 9, corresponding to an angle θ_1 of about 90° or about 45° respectively, because of the gravity force acting on the heavy crank-arms 6.

[0074] The inventors also found that, when the baler 70 was started from a favorable crank position, e.g. crank position C in FIG. 10, the start-up of the baler 70 never failed. In position C of FIG. 10, the crank 6 shows an angle θ_2 at an angular distance of about 300° with respect to the position which the crank 6 will assume after rotating the flywheel 2 in forward direction F until the plunger 13 reaches its distal position 8 inside the bale chamber 80.

[0075] This behavior was further investigated, and the start-up behavior of a flywheel 2 of a particular empty baler 70 and a particular tractor 17 combination, wherein the start-up sometimes failed, was measured, as shown in FIG. 11. The skilled person can easily make similar curves for other tractor 17 and baler 70 combinations, provided of course the tractor 17 has sufficient power to start-up the baler 70 under best-case conditions. In the particular case of FIG. 11, the empty baler 70 was started with its crank 6 in the position A, but another start-position could also be used, and the angular speed $\omega(t)$ of the flywheel 2 was measured, and plotted as shown in FIG. 11. On the horizontal axis the relative angular position θ of the crank 6 is shown with respect to its starting position. The angular velocity $\omega(t)$ of the flywheel 2 is shown on the left vertical axis, while the corresponding kinetic energy of the flywheel 2 is shown on the right vertical axis. It is to be noted that, due to the gearbox transmission ratio, the flywheel 2 rotates multiple times (e.g. 18 to 28 times) for each crank rotation. Only the first full revolution of the crank 6 after start-up is shown, which corresponds to a plurality of revolutions of the flywheel 2, e.g. 18 to 28 revolutions. As can be seen from FIG. 11, after the crank 6 has rotated over 30° , the kinetic energy E1 of the flywheel 2 is about 10 kJ, and the angular velocity ω_1 of the flywheel 2 is about 110 rpm. When the crank 6 has rotated over 270° , the kinetic energy E2 of the flywheel 2 is about 115 kJ, and the angular velocity ω_2 of the flywheel 2 is about 380 rpm. The exact numbers are not important, but it is clear from this example that the more time the baler 70 has before the first impact, the larger the angular velocity and thus the larger the kinetic energy at impact. In the example shown in FIG. 11 the angular velocity ratio ω_2/ω_1 is about $380/110 = 3.45$, but as kinetic energy (for a pure rotational movement) is proportional to the square of angular velocity, the kinetic energy ratio E_2/E_1 is about $115/10 = 11.5$. This example shows that the kinetic energy of the flywheel 2 before the first impact of the plunger 13 into the crop material 18 inside the bale

chamber 80 can be increased by a factor of 11.5 (more than ten), by starting from a favorable start-position (also called "launch position") such as e.g. crank position C in FIG. 10, as compared to starting from an unfavorable position, such as e.g. crank position A in FIG. 9. It is to be noted that the kinetic energy curve shown in FIG. 11, at least for the first revolution of the crank 6, is substantially monotonically increasing with angular distance θ . Thus the larger the value of θ , the more kinetic energy the flywheel 2 will have before the "first impact", i.e. before the plunger 13 reaches its distal position 8 in the bale chamber 80.

[0076] The principle of one of the embodiments of the invention as disclosed in co-pending patent application PCT/EP2014/053067 of the applicant and which is useful for understanding the present invention, is to provide a baler 70 wherein the flywheel 2 has gained sufficient kinetic energy before the first impact of the plunger 13 on the crop material 18 in the bale chamber 80, or, more accurately stated, since the amount of crop material 18 in the bale chamber may be a variable quantity and may even be absent, before the plunger 13 reaches its distal position 8 (see FIG. 10). This is obtained in the following way.

[0077] In a particular embodiment as disclosed in co-pending patent application PCT/EP2014/053067 of the applicant and which is useful for understanding the present invention, (not shown), the baler 70 may have a means 43b (e.g. a sensor) for determining a position of the crank 6, and the motor controller may be provided with a specially adapted algorithm for automatically rotating (e.g. reversing) the flywheel 2 to a predetermined launch position, e.g. a position from which - at the next startup - the crank 6 is situated at an angular distance of at least 90° (preferably at least 120° , more preferably at least 150° , even more preferably at least 180° , still even more preferably at least 210° , yet still even more preferably at least 240° , and most preferably at least 270°) in forward direction F from the position of the crank where the plunger 13 reaches its distal position 8. The predetermined launch position is preferably a position where the crank 6 is situated at an angular distance of at most 360° . When starting from this launch position, the risk that the baler 70 will fail to start-up is reduced, e.g. minimized, if not eliminated completely, thus the requirements for the auxiliary motor 5 can be much reduced, as it only needs to be able to slowly rotate (e.g. reverse) the flywheel 2.

[0078] A further embodiment of the invention as disclosed in another co-pending patent application PCT/EP2014/056130 of the applicant and which is useful for understanding the present invention, relates to a baler 70 comprising:

- a shaft 3 for coupling with a power take-off, and a flywheel 2 connected to the shaft 3;
- a plunger 13 connected to the flywheel 2 via a crank 6, the plunger 13 being adapted for performing a

reciprocal movement between a near position 7 suitable for adding crop material in a bale chamber 80 and a distal position 8 suitable for compressing crop material in the bale chamber 80;

- an auxiliary motor 5 connectable to the flywheel 2 and adapted for rotating said flywheel depending on a control signal;
- a disc brake system 40 comprising a brake disc 41 adapted for braking the flywheel 2 and having a toothed rim 59, the auxiliary motor 5 being engageable to the toothed rim 59 of the brake disc 41;
- means 43 for determining a position of the crank 6,
- a motor controller connected to the said means 43, and connected to the auxiliary motor 5 for providing the control signal, the motor controller being provided with an algorithm for determining the control signal for automatically rotating the flywheel 2 to a pre-determined launch position.

[0079] Another aspect of the invention as disclosed in co-pending patent application PCT/EP2014/056130 of the applicant and which is useful for understanding the present invention, relates to a method for positioning a crank 6 of an agricultural baler 70 as defined directly here-above in a predefined launch position, the method comprising the steps of:

- Determining the position of the crank 6 based on data collected by the means 43,
- Determining the control signal based on said position,
- Activating said auxiliary motor 5 based on said control signal so as to position said crank 6 in said predefined launch position.

[0080] The above-described method embodiments of the invention as disclosed in co-pending patent application PCT/EP2014/056130 of the applicant and which is useful for understanding the present invention, may be implemented in a processing system 1 (e.g. as part of the motor controller) such as shown in FIG. 12. FIG. 12 shows one configuration of a processing system 1 that includes at least one programmable processor 10 coupled to a memory subsystem 140 that includes at least one form of memory 4, e.g., RAM, ROM, FLASH, and so forth. It is to be noted that the processor 10 or processors may be a general purpose, or a special purpose processor, and may be for inclusion in a device, e.g. a chip that has other components that perform other functions. Thus, one or more aspects of the present invention can be implemented in digital electronic circuitry, or in computer hardware, firmware, software, or in combinations of them. The processing system 1 may include a storage subsystem 12 that has at least one input port (e.g. disk drive and/or CD-ROM drive and/or DVD drive and/or USB interface, ...). In some implementations, a display system, a keyboard, and/or a pointing device may be included as part of a user interface subsystem 9 to provide for

a user to manually input information. Ports for outputting data also may be included. More elements such as network connections, interfaces to various devices, and so forth, may be included, but are not illustrated in FIG. 12.

- 5 The various elements of the processing system 1 may be coupled in various ways, including via a bus subsystem 11 shown in FIG. 12 for simplicity as a single bus, but it will be understood to those skilled in the art to include a system of at least one bus. The memory of the memory subsystem 140 may at some time hold part or all (in either case shown as 4) of a set of instructions that when executed on the processing system 1 implement the steps of the method embodiments described herein. Thus, while the hardware of a processing system 1 such as shown in FIG. 12 is prior art, a system that includes the instructions to implement aspects of the methods for positioning a crank 6 of an agricultural baler 70 in a predefined position by means of a brake disc 41 having a toothed rim 59 is not prior art, and therefore FIG. 12 is not labeled as prior art.

- [0081]** The invention as disclosed in co-pending patent application PCT/EP2014/056130 of the applicant and which is useful for understanding the present invention, also includes a computer program or computer program product which provides the functionality of any of the methods according to embodiments of the present invention when executed on a computing device. Such computer program product can be tangibly embodied in a carrier medium carrying machine-readable code for execution by a programmable processor. The present invention thus also relates to a carrier medium carrying a computer program product that, when executed on computing means, provides instructions for executing any of the methods as described above. The term "carrier medium" refers to any medium that participates in providing instructions to a processor for execution. Such a medium may take many forms, including but not limited to, non-volatile media, and transmission media. Non volatile media includes, for example, optical or magnetic disks, such as a storage device which is part of mass storage. Common forms of computer readable media include, a CD-ROM, a DVD, a flexible disk or floppy disk, a memory key, a tape, a memory chip or cartridge or any other medium from which a computer can read. Various forms of computer readable media may be involved in carrying one or more sequences of one or more instructions to a processor for execution. The computer program or computer program product can be carried on an electrical carrier signal. The computer program product can also be transmitted via a carrier wave in a network, such as a LAN, a WAN or the Internet. Transmission media can take the form of acoustic or light waves, such as those generated during radio wave and infrared data communications. Transmission media include coaxial cables, copper wire and fibre optics, including the wires that comprise a bus within a computer.

REFERENCES

[0082]

1	Processing system
2	flywheel
3	shaft
4	memory
5	auxiliary motor
6	crank
7	near position
8	distal position
9	user interface subsystem
10	programmable processor
11	bus subsystem
12	storage subsystem
13	plunger
14	tractor controller circuit
15	tractor PTO
16	bale
17	tractor
18	crop material
24	packer mechanism
25	frame
26	forwardly extending tongue
27	pick-up assembly
28	feeder duct
29	stuffer mechanism
31	discharge
34	gearbox
40	disc brake system
41	brake disc
42	brake claw
43	sensor
43a	sensor for detecting open door/panel
43b	position sensor for the crank
44	input device (of the baler)
44a	input device for activating the disk brake system
44b	input device for activating the auxiliary motor
45	input device (of the tractor)
48	emergency stop input device
49	hydraulic system
51	brake caliper
53	control valve
54	hydraulic lines
56	baler controller
57	gear wheel
58	brake pads
59	toothed rim of a brake disk
70	baler
80	bale chamber
140	memory subsystem
156	toothed outer rim of a flywheel
207	start up device
θ	angular position or angular distance
E	kinetic energy
ω	angular velocity
F	normal/forward direction

R	backward/reverse direction
D	outer diameter of a flywheel
d	outer diameter of a brake disk
C1	center of mass of a flywheel
5	C2 center of mass of a brake disk

Claims

- 10 1. A baler flywheel assembly comprising:
- a flywheel (2);
- 15 **characterized in that** the baler flywheel assembly further comprises a brake disc (41) adapted for breaking the flywheel (2), the brake disc (41) having a toothed rim (59).
- 20 2. A baler gearbox assembly, comprising:
- a baler gearbox (34);
- the baler flywheel assembly according to claim 1, mounted to the baler gearbox (34); and
- a brake caliper (51) mounted to the baler gearbox (34) for engaging with the brake disc (41) of the baler flywheel assembly.
- 25 3. An agricultural baler (70) comprising a baler flywheel assembly according to claim 1, the agricultural baler further comprising:
- a shaft (3) for coupling with a power take-off (15), and the flywheel (2) connected to the shaft (3);
- an auxiliary motor (5) connectable to the flywheel (2);
- 30 **characterized in that:**
- the auxiliary motor (5) being engageable to the toothed rim (59) of the brake disc (41).
- 35 4. The agricultural baler (70) according to claim 3, wherein the toothed rim of the brake disc (41) is a toothed outer rim (59).
- 40 5. The agricultural baler (70) according to anyone of the claims 3 or 4, wherein the auxiliary motor (5) is adapted for helping to accelerate the flywheel (2) during baler start-up.
- 45 6. The agricultural baler (70) according to any of the claims 3 to 5, wherein the auxiliary motor (5) is adapted for rotating the flywheel (2) backward.
- 50 7. The agricultural baler (70) according to any of the claims 3 to 6, wherein the brake disc (41) is mounted on the flywheel (2).
- 55

8. The agricultural baler (70) according to any of the claims 3 to 7, wherein the centre of mass (c2) of the brake disc (41) substantially coincides with the centre of mass (c1) of the flywheel (2). 5
9. The agricultural baler (70) according to any of the claims 3 to 8, wherein the baler (70) further comprises a gearbox (34) and the disc brake system (40) further comprises at least one brake caliper (51), and wherein the brake caliper (51) is mounted to the gearbox (34). 10
10. The agricultural baler (70) according to claim 9, further comprising a handle connected to the at least one brake caliper (51) via a cable. 15
11. The agricultural baler (70) according to claim 9, wherein the at least one brake caliper (51) is a hydraulic caliper, and wherein the baler (70) further comprises a hydraulic circuit (49) fluidly connected to the brake caliper (51), and a baler controller (56) for activating and deactivating the hydraulic brake caliper (51). 20
12. The agricultural baler (70) according to any one of the claims 3 to 11, wherein the auxiliary motor (5) is adapted for rotating said flywheel (2) depending on at least one control signal. 25
13. A tractor and baler combination, comprising: 30
- the agricultural baler (70) according to claim 11 or 12;
 - a tractor (17) having a PTO (15) connectable to the shaft (3) of the baler (70) for accelerating the flywheel (2) of the baler (70), and wherein the tractor (17) further comprises a tractor controller circuit for sending a command to the baler controller (56) for selectively activating the disc brake system (40) and/or the auxiliary motor (5). 35 40

Patentansprüche

1. Ballenpressen-Schwungscheiben-Anordnung mit: 45
- einer Schwungscheibe (2);
- dadurch gekennzeichnet, dass** die Ballenpressen-Schwungscheiben-Anordnung des Weiteren eine Bremsscheibe (41) umfasst, die zum Bremsen des Schwungrades (2) geeignet ist, wobei die Bremsscheibe (41) einen Zahnkranz (59) aufweist. 50
2. Ballenpressen-Getriebe-Anordnung mit: 55
- einem Ballenpressen-Getriebe (34);
 - der Ballenpressen-Schwungscheiben-Anord-

nung nach Anspruch 1, die an dem Ballenpressen-Getriebe (34) angebracht ist; und

- einem Bremsattel (51), der an dem Ballenpressen-Getriebe (34) angebracht ist, zum Eingriff mit der Bremsscheibe (41) der Ballenpressen-Schwungscheiben-Anordnung.

3. Landwirtschaftliche Ballenpresse (70) mit einer Ballenpressen-Schwungscheiben-Anordnung nach Anspruch 1, wobei die landwirtschaftliche Ballenpresse weiterhin aufweist:

- eine Welle (3) zum Koppeln mit einer Zapfwelle bzw. einem Nebenabtrieb (15) und der Schwungscheibe (2), die mit der Welle (3) verbunden ist;
- einen Hilfsmotor (5), der mit der Schwungscheibe (2) verbindbar ist;

dadurch gekennzeichnet, dass:

der Hilfsmotor (5) mit dem Zahnkranz (59) der Bremsscheibe (41) in Eingriff bringbar ist.

4. Landwirtschaftliche Ballenpresse (70) nach Anspruch 3, wobei der Zahnkranz der Bremsscheibe (41) ein mit Zähnen versehener äußerer Kranz (59) ist.
5. Landwirtschaftliche Ballenpresse (70) nach einem der Ansprüche 3 oder 4, wobei der Hilfsmotor (5) dazu eingerichtet ist, um die Schwungscheibe (2) während des Startens der Ballenpresse beim Beschleunigen zu unterstützen.
6. Landwirtschaftliche Ballenpresse (70) nach einem der Ansprüche 3 bis 5, wobei der Hilfsmotor (5) dazu eingerichtet ist, die Schwungscheibe (2) rückwärts in Rotation zu versetzen.
7. Landwirtschaftliche Ballenpresse (70) nach einem der Ansprüche 3 bis 6, wobei die Bremsscheibe (41) an der Schwungscheibe (2) angebracht ist.
8. Landwirtschaftliche Ballenpresse (70) nach einem der Ansprüche 3 bis 7, wobei der Massenschwerpunkt (c2) der Bremsscheibe (41) im Wesentlichen mit dem Massenschwerpunkt (c1) der Schwungscheibe (2) übereinstimmt.
9. Landwirtschaftliche Ballenpresse (70) nach einem der Ansprüche 3 bis 8, wobei die Ballenpresse (70) des Weiteren ein Getriebe (34) aufweist und das Scheibenbremssystem (40) des Weiteren mindestens einen Bremsattel (51) aufweist, und wobei der Bremsattel (51) an dem Getriebe (34) angebracht ist.

10. Landwirtschaftliche Ballenpresse (70) nach Anspruch 9, die des Weiteren einen Einstellhebel aufweist, der mit mindestens einem Bremssattel (51) über ein Seil verbunden ist.

11. Landwirtschaftliche Ballenpresse (70) nach Anspruch 9, wobei mindestens ein Bremssattel (51) ein hydraulischer Bremssattel ist, und wobei die Ballenpresse (70) des Weiteren einen Hydraulikkreislauf (49) der hydraulisch mit dem Bremssattel (51) verbunden ist, und eine Ballenpressensteuereinrichtung (56) zum Aktivieren und Deaktivieren des hydraulischen Bremssattels (51) aufweist.

12. Landwirtschaftliche Ballenpresse (70) nach einem der Ansprüche 3 bis 11, wobei der Hilfsmotor (5) dazu eingerichtet ist, die Schwungscheibe (2) abhängig von mindestens einem Steuersignal in Rotation zu versetzen.

13. Kombination aus Traktor und Ballenpresse mit:

- der landwirtschaftlichen Ballenpresse (70) nach Anspruch 11 oder 12;
- einem Traktor (17) mit einer Zapfwelle bzw. einem Nebenabtrieb (PTO, power take-off) (15), die bzw. der mit der Welle (3) der Ballenpresse (70) verbindbar ist, um die Schwungscheibe (2) der Ballenpresse (70) zu beschleunigen, und wobei der Traktor (17) des Weiteren eine Traktorensteuerungsschaltkreis aufweist, um einen Befehl an die Ballenpressensteuereinheit (56) zu senden, um das Bremsscheibensystem (40) und/oder den Hilfsmotor (5) wahlweise zu aktivieren.

Revendications

1. Ensemble de volant de ramasseuse-presse à balles comprenant :

- un volant (2),

caractérisé en ce que l'ensemble de volant de ramasseuse-presse à balles comprend en outre un disque de frein (41) conçu pour freiner le volant (2), le disque de frein (41) comportant une couronne dentée (59).

2. Ensemble de boîte de transmission de ramasseuse-presse à balles, comprenant :

- une boîte de transmission (34) de ramasseuse-presse à balles,
- l'ensemble de volant de ramasseuse-presse à balles selon la revendication 1 monté sur la boîte de transmission (34) de ramasseuse-presse à

balles, et

- un étrier de frein (51) monté sur la boîte de transmission (34) de ramasseuse-presse à balles pour engager le disque de frein (41) de l'ensemble de volant de ramasseuse-presse à balles.

3. Ramasseuse-presse à balles agricole (70) comprenant un ensemble de volant de ramasseuse-presse à balles selon la revendication 1, la ramasseuse-presse à balles comprenant en outre :

- un arbre (3) pour raccorder une prise de force (15), et le volant (2) connecté à l'arbre (3), et
- un moteur auxiliaire (5) pouvant être connecté au volant (2),

caractérisée en ce que :

le moteur auxiliaire (5) peut être engrené dans la couronne dentée (59) du disque de frein (41).

4. Ramasseuse-presse à balles agricole (70) selon la revendication 3, dans laquelle la couronne dentée du disque de frein (41) est une couronne dentée extérieure (59).

5. Ramasseuse-presse à balles agricole (70) selon la revendication 3 ou 4, dans laquelle moteur auxiliaire (5) est conçu pour aider à accélérer le volant (2) pendant le démarrage de la ramasseuse-presse à balles.

6. Ramasseuse-presse à balles agricole (70) selon l'une quelconque des revendications 3 à 5, dans laquelle le moteur auxiliaire (5) est conçu pour faire tourner le volant (2) en arrière.

7. Ramasseuse-presse à balles agricole (70) selon l'une quelconque des revendications 3 à 6, dans laquelle le disque de frein (41) est monté sur le volant (2).

8. Ramasseuse-presse à balles agricole (70) selon l'une quelconque des revendications 3 à 7, dans laquelle le centre de masse (c2) du disque de frein (41) coïncide sensiblement avec le centre de masse (c1) du volant (2).

9. Ramasseuse-presse à balles agricole (70) selon l'une quelconque des revendications 3 à 8, dans laquelle la ramasseuse-presse à balles (70) comprend en plus une boîte de transmission (34) et le système de frein à disque (40) comprend en outre au moins un étrier de frein (51), et dans laquelle l'étrier de frein (51) est monté sur la boîte de transmission (34).

10. Ramasseuse-presse à balles agricole (70) selon la

revendication 9, comprenant en plus une poignée reliée à au moins un étrier de frein (51) par un câble.

11. Ramasseuse-presse à balles agricole (70) selon la revendication 9, dans laquelle le au moins un étrier de frein (51) est un étrier hydraulique, et la ramasseuse-presse à balles (70) comprenant en outre un circuit hydraulique (49) relié fluidiquement à l'étrier de frein (51), et une unité de commande (56) pour enclencher et désenclencher l'étrier de frein hydraulique (51). 5
10
12. Ramasseuse-presse à balles agricole (70) selon l'une quelconque des revendications 3 à 11, dans laquelle moteur auxiliaire (5) est conçu pour faire tourner ledit volant (2) en fonction d'au moins un signal de commande. 15
13. Combinaison de tracteur et de ramasseuse-presse à balles, comprenant : 20
- la ramasseuse-presse à balles agricole (70) selon la revendication 11 ou 12 ;
 - un tracteur (17) possédant une prise de force (15) pouvant être connectée à l'arbre (3) de la ramasseuse-presse à balles (70) pour accélérer le volant (2) de la ramasseuse-presse à balles (70), et le tracteur (17) comprenant en outre un circuit d'unité de commande du tracteur pour envoyer une commande à l'unité de commande (56) de la ramasseuse-presse à balles afin d'enclencher sélectivement le système de frein à disque (40) et/ou le moteur auxiliaire (5). 25
30

35

40

45

50

55

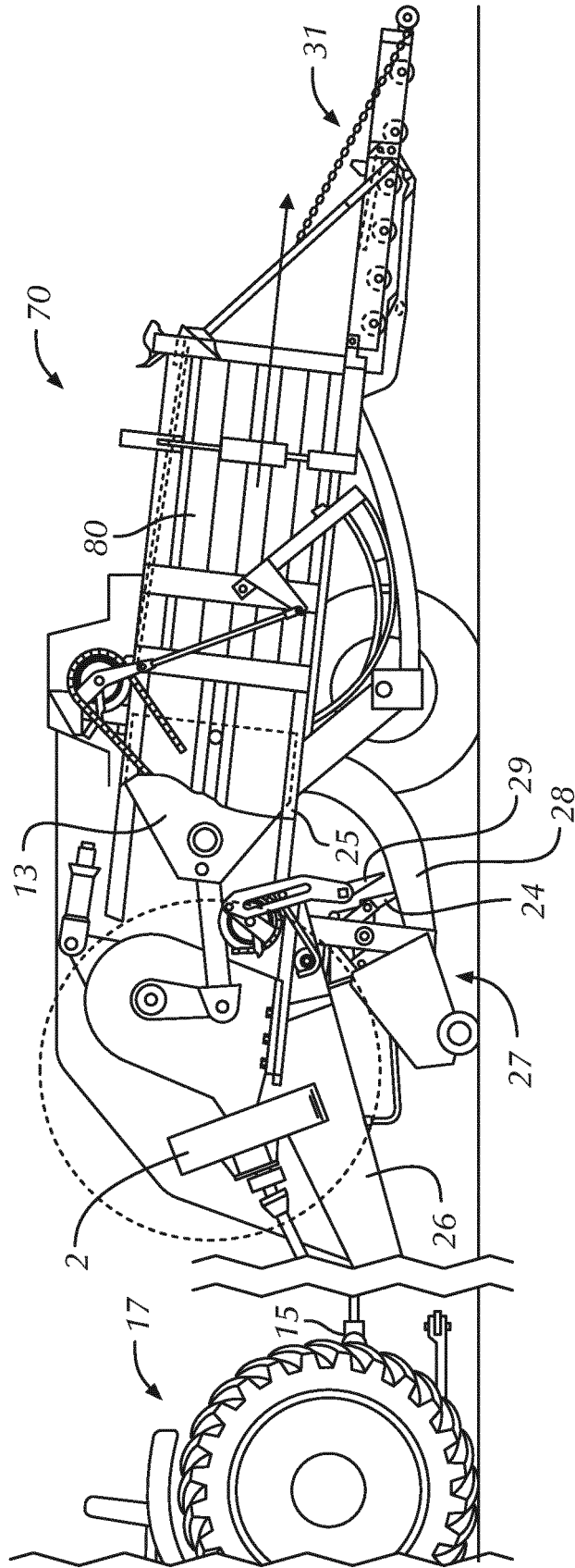

FIG. 1

FIG. 2
(Prior Art)

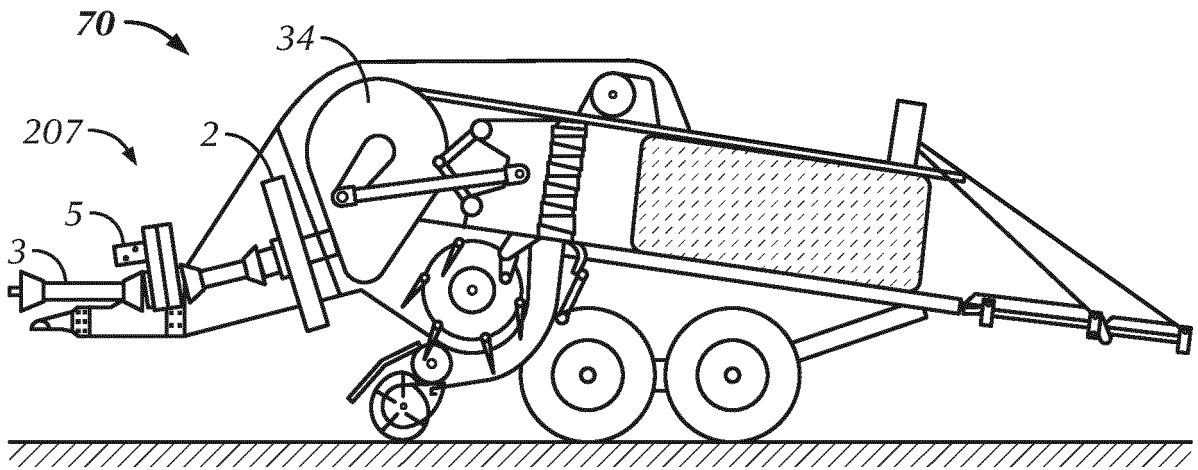
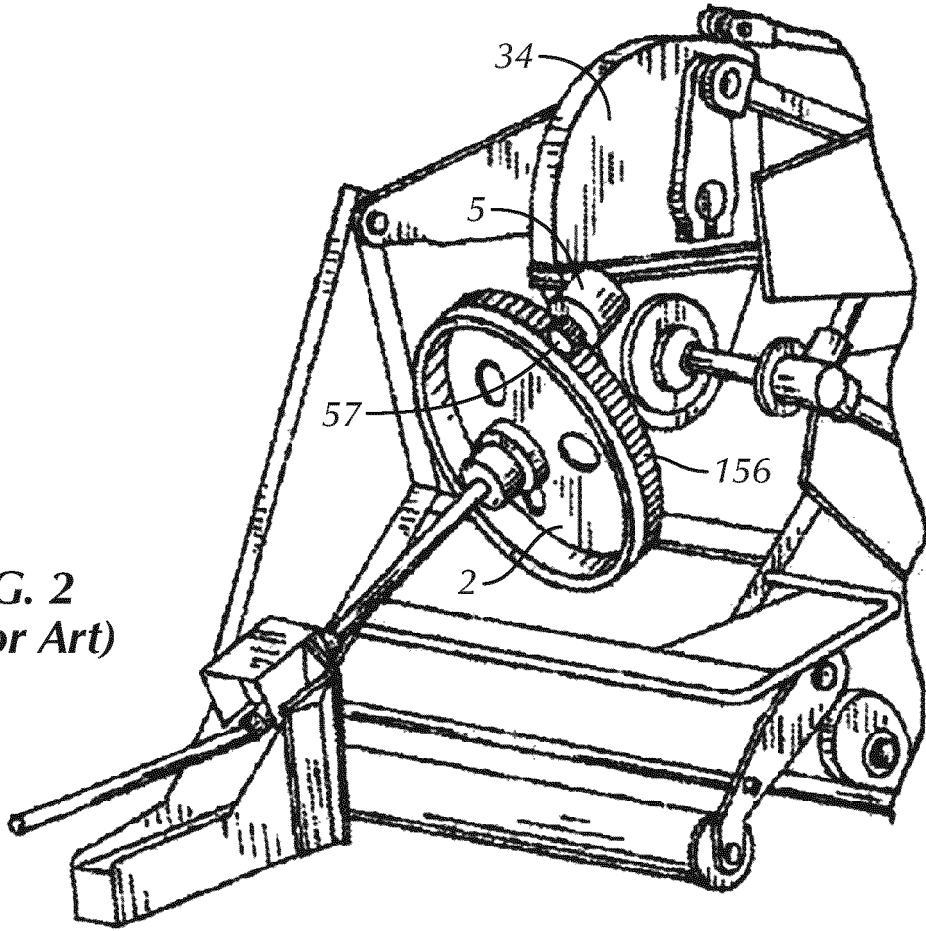

FIG. 3
(Prior Art)

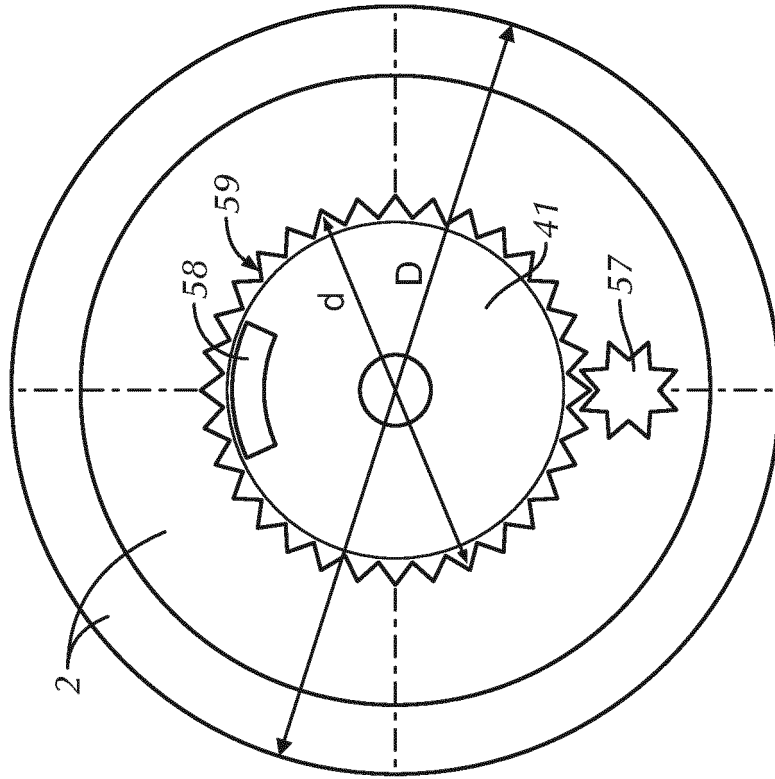

FIG. 5

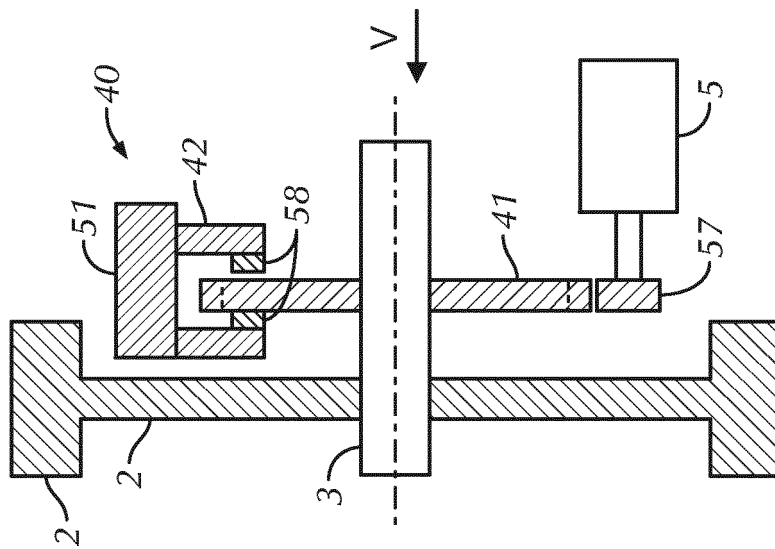

FIG. 4

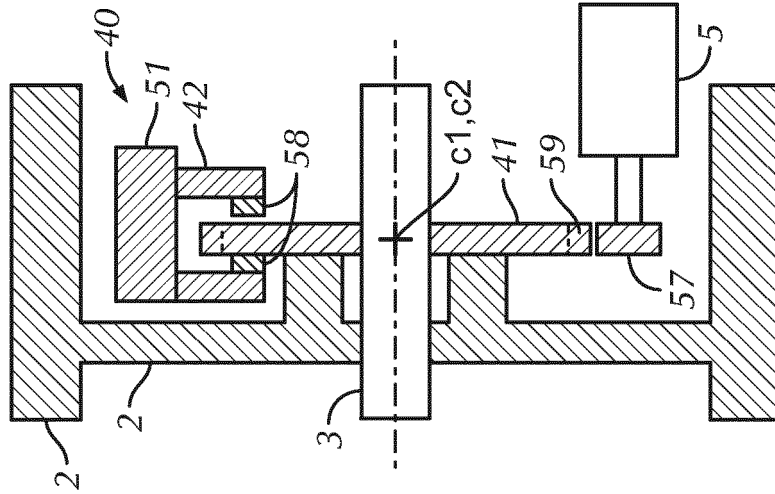

FIG. 6

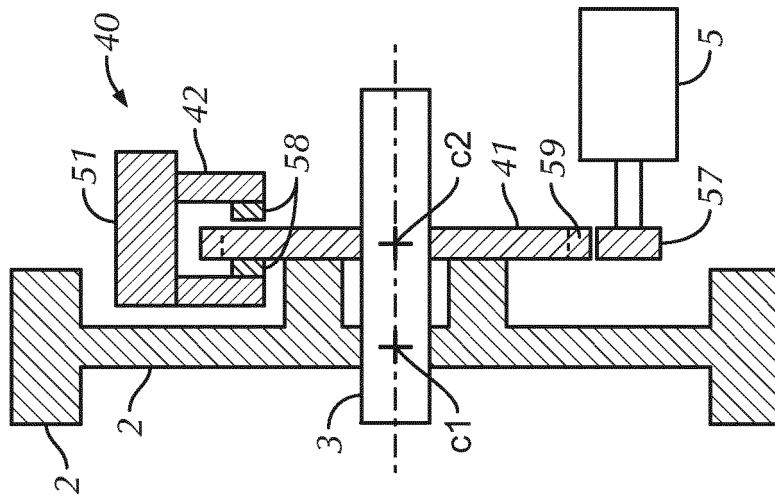

FIG. 7

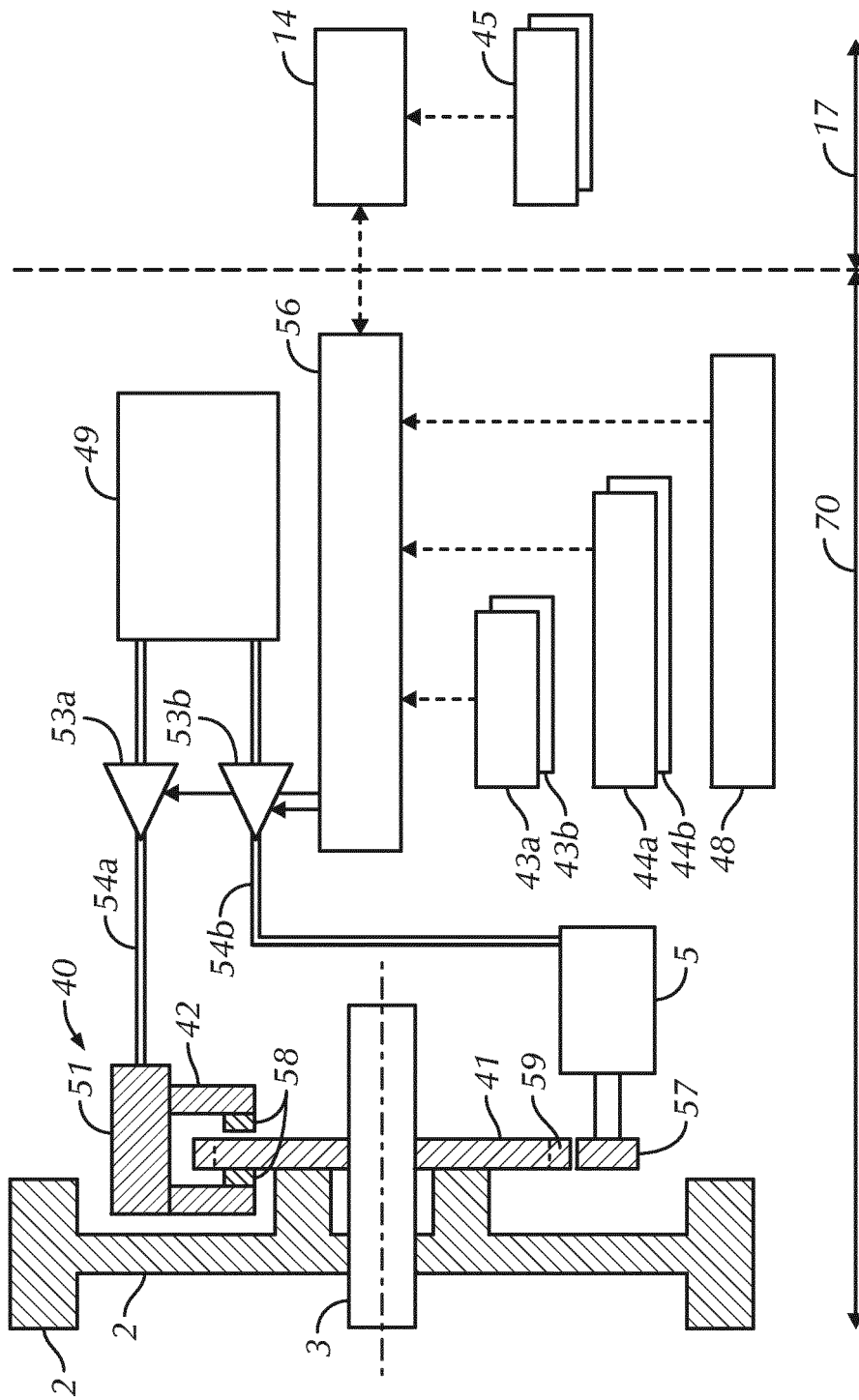

FIG. 8

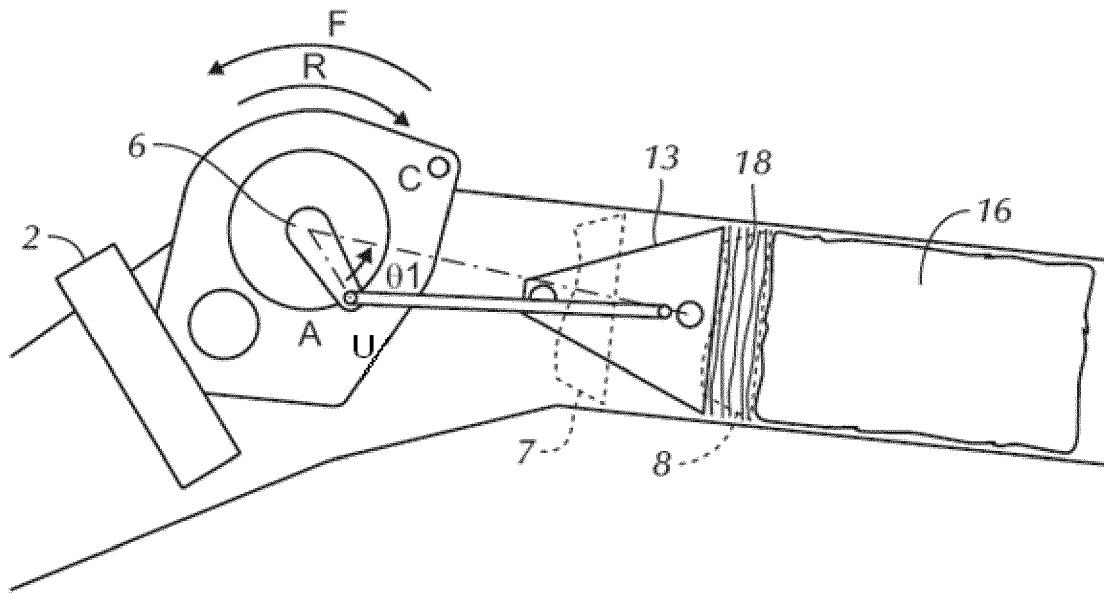

FIG. 9

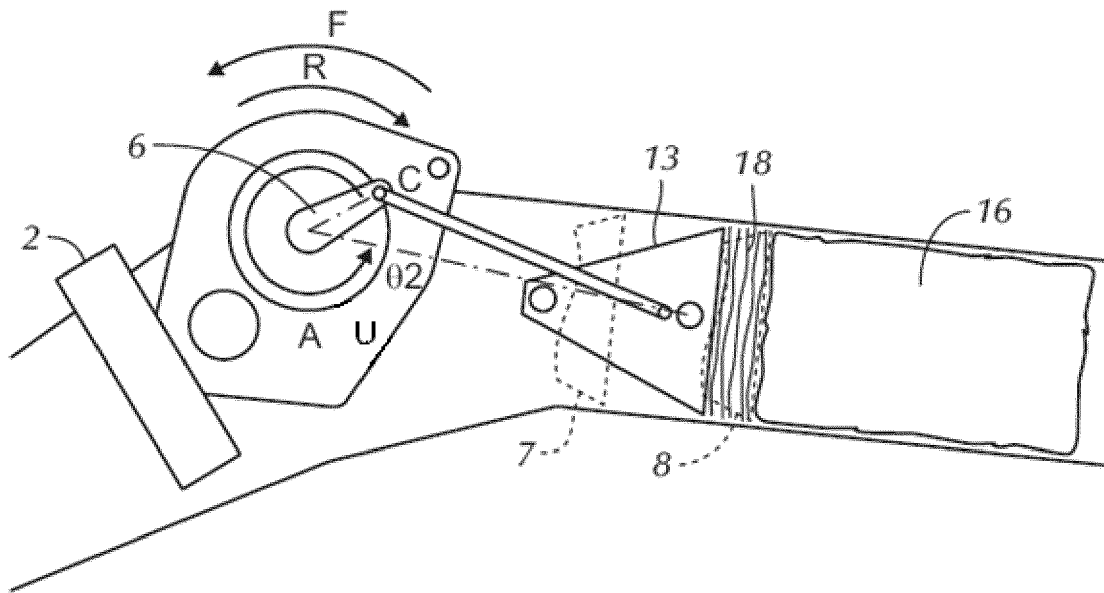

FIG. 10

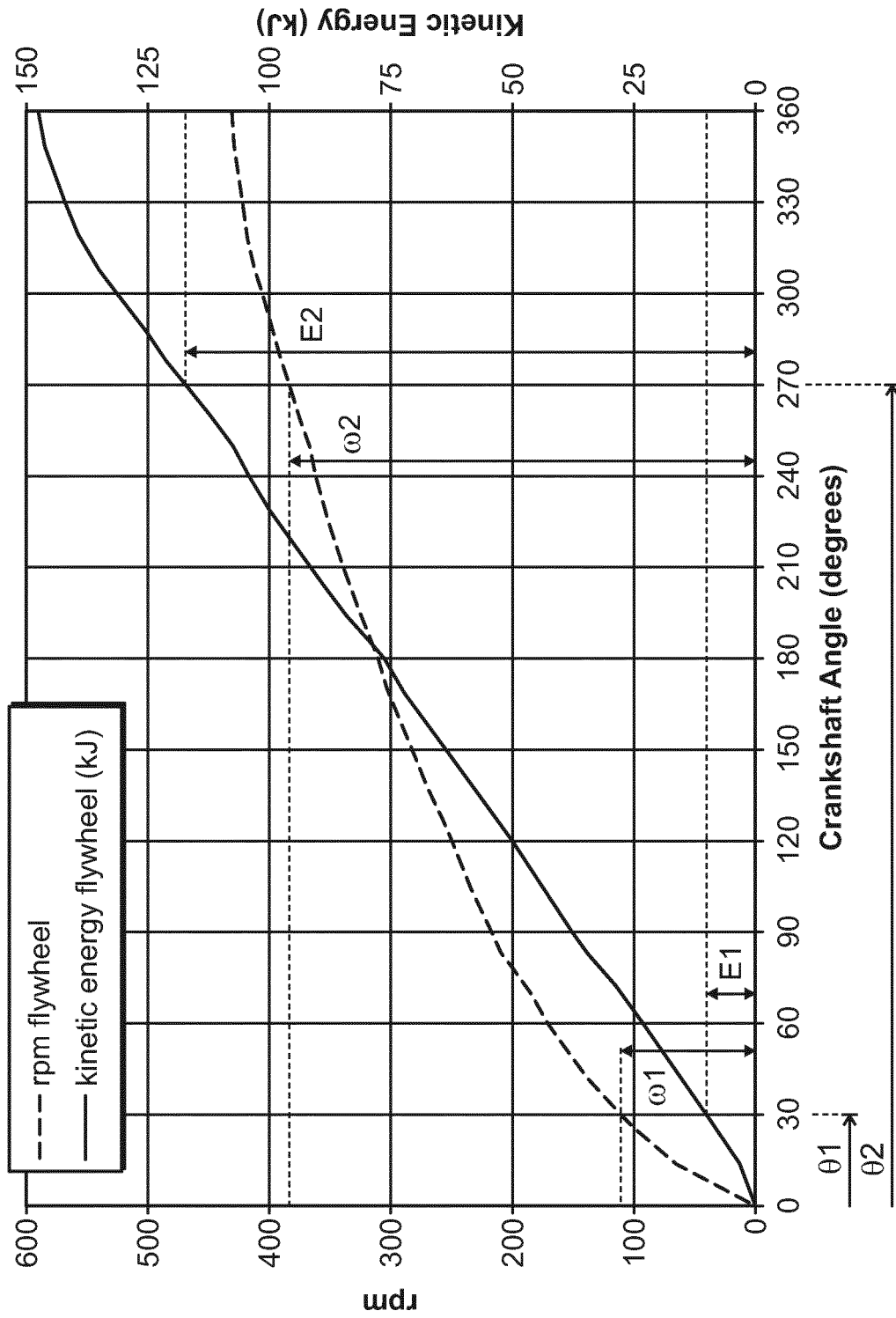

FIG. 11

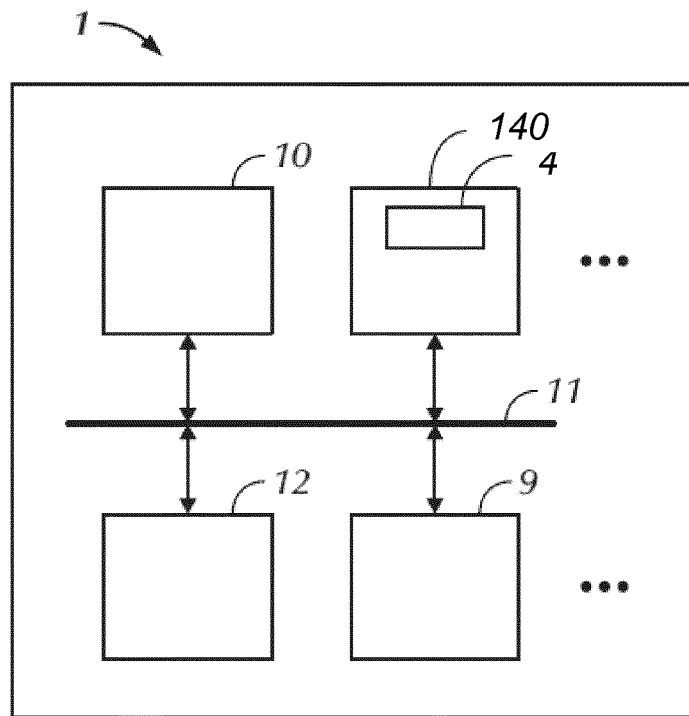

FIG. 12

REFERENCES CITED IN THE DESCRIPTION

This list of references cited by the applicant is for the reader's convenience only. It does not form part of the European patent document. Even though great care has been taken in compiling the references, errors or omissions cannot be excluded and the EPO disclaims all liability in this regard.

Patent documents cited in the description

- EP 1974601 A [0005]
- EP 2193707 A [0006]
- EP 2014053067 W [0035] [0061] [0076] [0077]
- EP 2014056130 W [0078] [0079] [0080] [0081]