



US 20030231352A1

(19) **United States**

(12) **Patent Application Publication**

Chen et al.

(10) **Pub. No.: US 2003/0231352 A1**

(43) **Pub. Date: Dec. 18, 2003**

(54) **OPTICAL CARRIAGE OF SCANNER AND METHOD FOR THE SAME**

Publication Classification

(75) Inventors: **Tsung-Yin Chen, HSIN-CHU (TW); Chun-I Hsiao, HSIN-CHU (TW)**

(51) **Int. Cl.⁷ H04N 1/04**

(52) **U.S. Cl. 358/474; 358/484**

Correspondence Address:

LOWE HAUPTMAN GILMAN & BERNER, LLP

**1700 Diagonal Road, Suite 310
Alexandria, VA 22314 (US)**

(57) **ABSTRACT**

(73) Assignee: **UMAX DATA SYSTEMS INC.**

(21) Appl. No.: **10/166,750**

An optical carriage of scanner has a mirror assembly and a device assembly, the mirror assembly has a mirror mount, some mirror holder, and some supporters, and the device assembly has a chassis. In this invention, the mirror assembly and the device assembly are mechanically connected after separately formation. Further, to ensure correct shape of these mirror holders and these supporters, they could be formed by metal punch, plastic ejection, or plastic process.

(22) Filed: **Jun. 12, 2002**

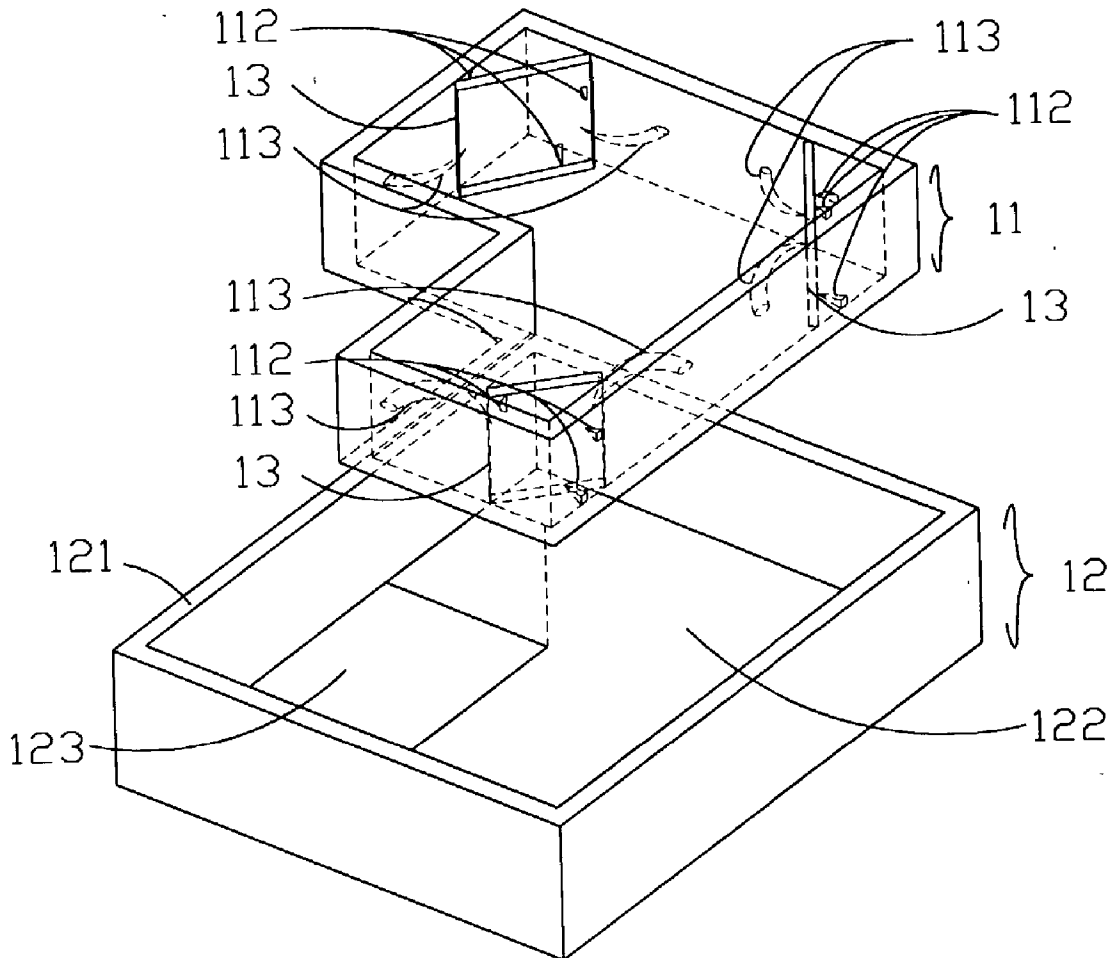

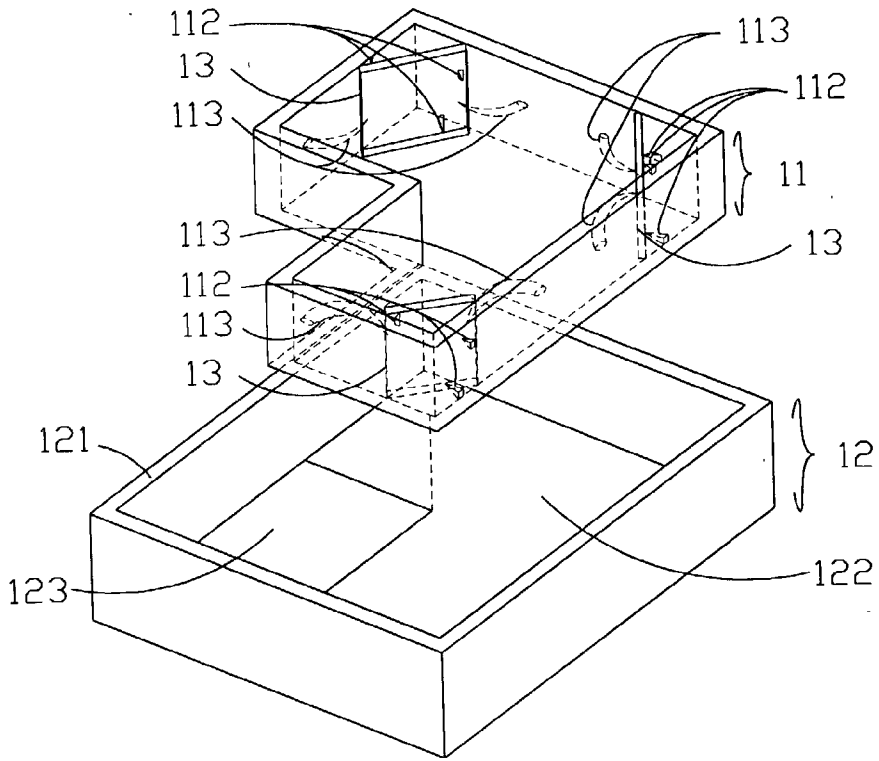

FIG. 1A

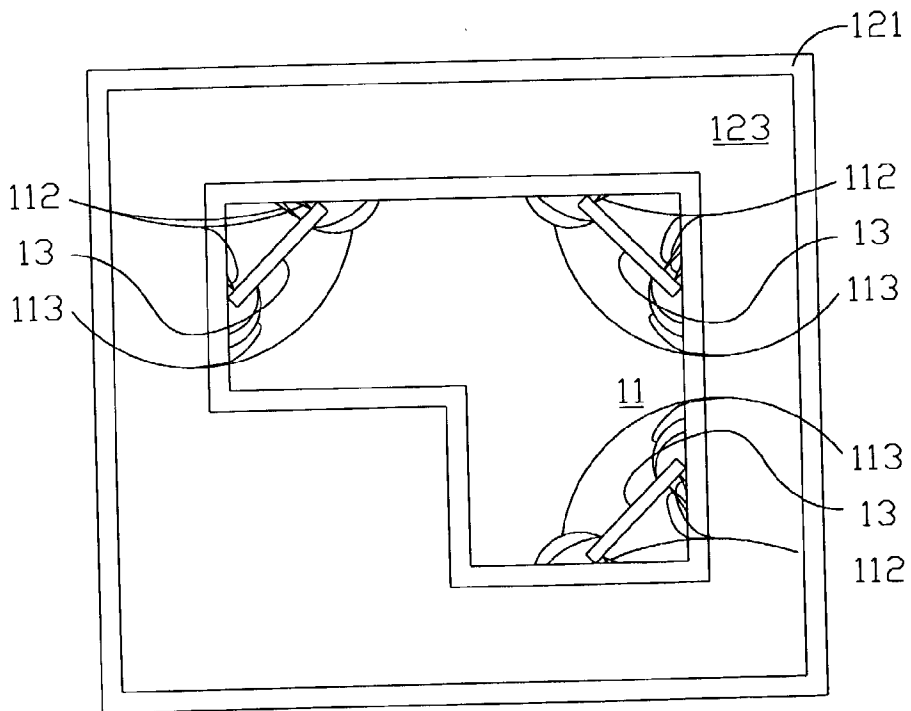

FIG. 1B

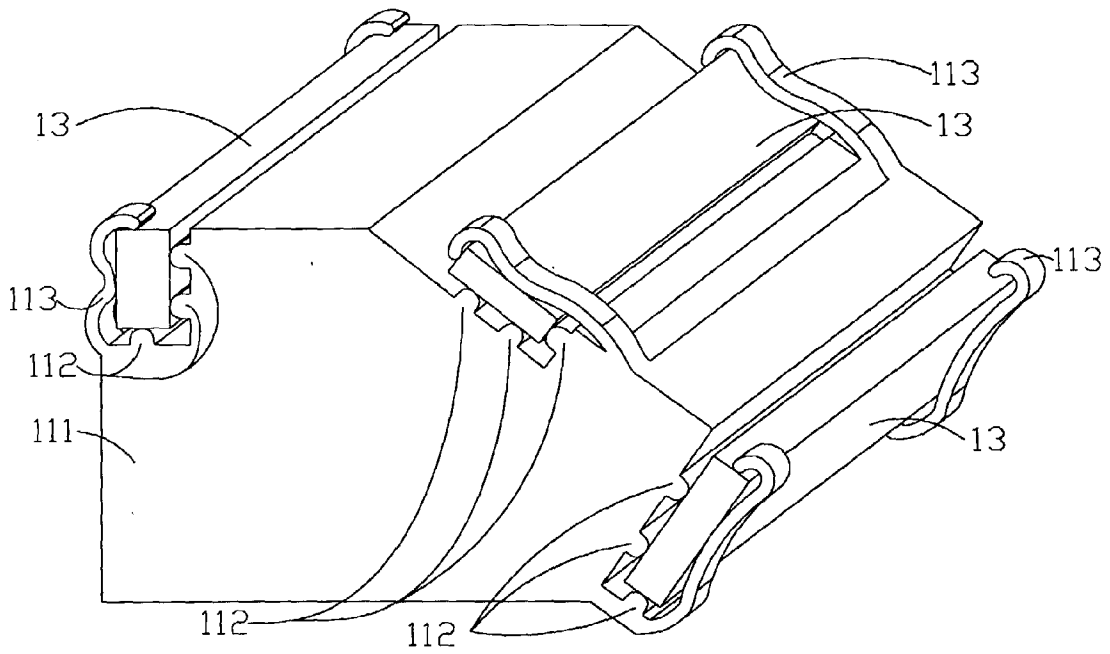

FIG.1C

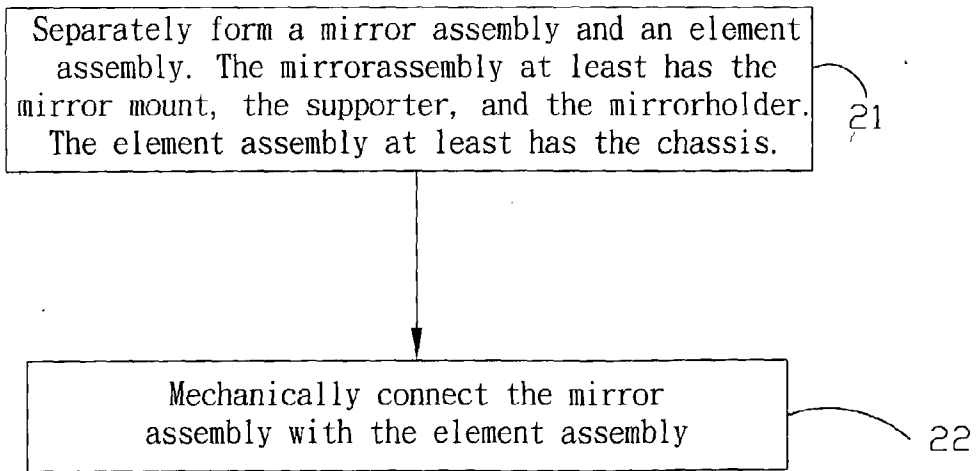

FIG.2A

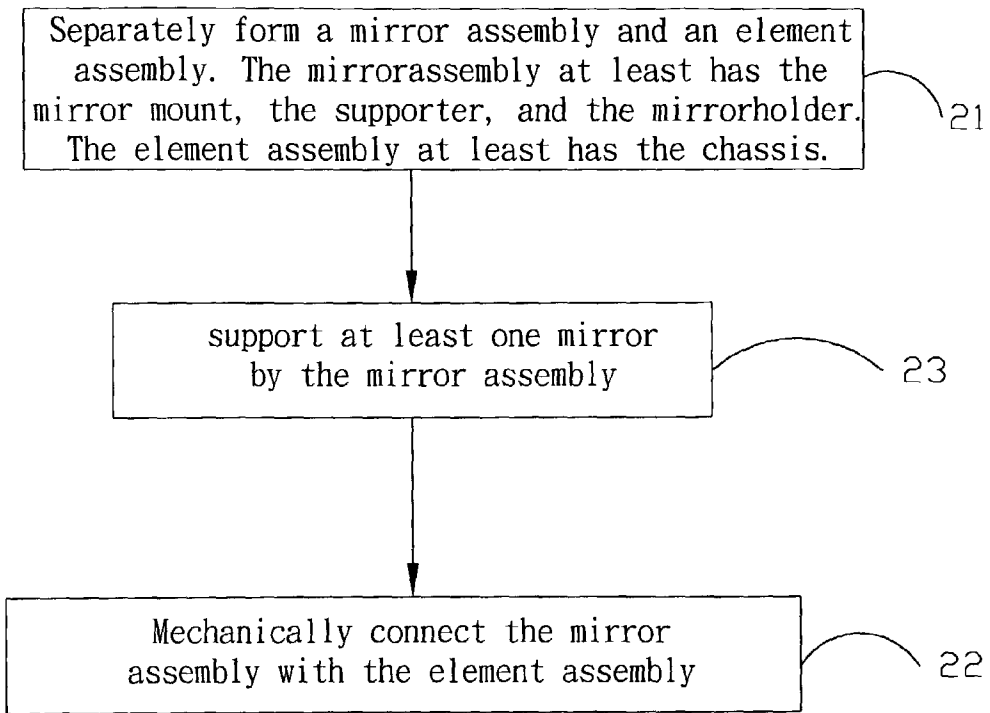

FIG.2B

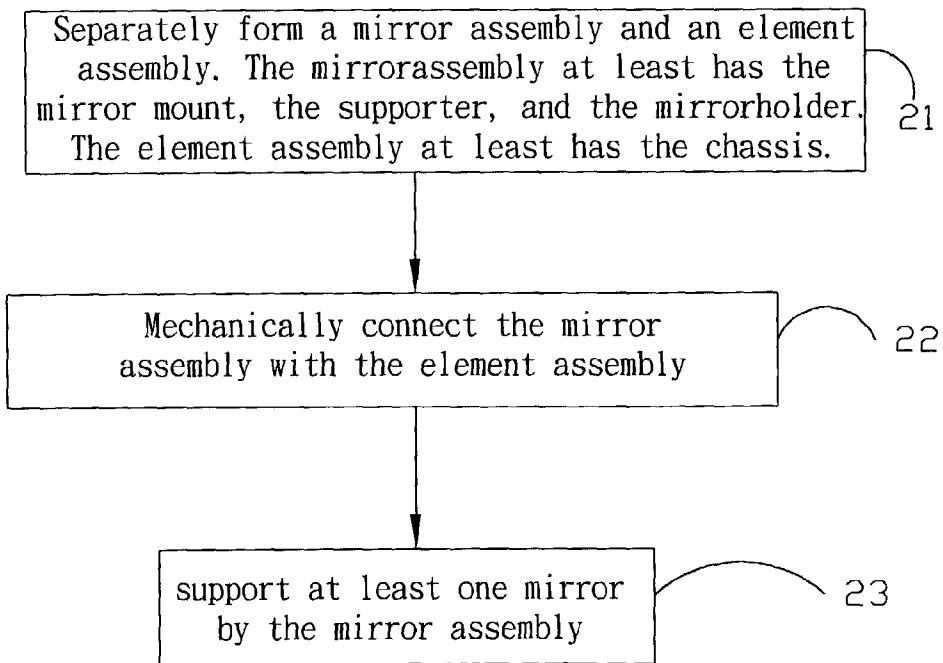

FIG.2C

OPTICAL CARRIAGE OF SCANNER AND METHOD FOR THE SAME

BACKGROUND OF THE INVENTION

[0001] 1. Field of the Invention

[0002] This invention generally relates to the optical carriage of scanner and method for forming the same, moreover, the invention relates to the following issues: reduces errors, simplifying construction, reducing cost and increasing precision.

[0003] 2. Description of the Prior Art

[0004] The conventional scanner usually locates some mirrors in an optical carriage, thus, the location of the mirrors could be changed to achieve some predetermined functions by moving the optical carriage. Further, the mirror mount usually is a combination of an element assembly, which has a chassis, and a mirror assembly, which has a mirror mount and a support device. Herein, the mirror assembly is used to modify the propagation path of the light, and the element assembly is used to carry some elements for processing the light.

[0005] For example, the conventional scanner usually puts some mirrors in and on an optical carriage, and acquires the complete image by moving the optical carriage through the whole scanned document. In the example, the mirror assembly has some mirrors and a mount for fixing the mirrors, the element assembly has some devices, such as lens and charger coupled device, and a chassis for supporting and fixing both the devices and the mirror assembly.

[0006] The conventional technologies usually form the whole optical carriage, include the mirror mount and the supporters, by the plastic ejection, and then separately locate both mirrors and devices into the optical carriage. The advantages of the previous conventional technologies have low cost and simply fabrication.

[0007] However, because that the result of the plastic ejection is strongly dependent on the fabrication conditions which would be changed during the fabrication of different plastic ejection, the shape of the different optical carriages is hard to be exact similar. Further, because the whole optical carriage is formed at the same time, it is difficult to separately amend the details of the optical carriage. Thus, the shape and the position of the real supporters usually are different to the predetermined supporter, and both mirrors deviation and wrong propagation path of light are unavoidable. Moreover, because that the hardness and the rigidity of the plastic material is weak, because that the weight of the mirror is irnegligible, and because the supporters suffer extra stress during the moving process of the optical carriage, the supporters would be damaged and/or deformed even the fabrication is thorough prefect, and both mirrors deviation and wrong propagation path of light are unavoidable.

SUMMARY OF THE INVENTION

[0008] One main object of the invention is to provide an optical carriage of scanner, moreover, the provided invention have the following advantages such as low cost, low errors, simply fabrication, and high precision.

[0009] Another object of the invention is to provide an optical carriage of scanner, the provided invention could

archive the previous advantages without strongly amending the conventional optical carriage of scanner.

[0010] Still an object of the invention is to provide a method for forming the previous provided optical carriage of scanner.

[0011] One preferred embodiment of this invention is an optical carriage of scanner, and is a combination of at least a mirror assembly and an element assembly. The mirror assembly at least has a mirror mount, some supporters and some mirror holders. These supporters are located and protruded mirror mount, and each supporter is separated from other, supporters. These mirror holders are located in and protruded the mirror mount, and each mirror holder has two terminals where one terminal is connected with the mirror mount but another terminal is separated from the mirror mount. The element assembly at least has a chassis which are divided into a device area and a separated mirror area. Wherein, because the mirror area is covered by the mirror assembly after the element assembly is connected with the mirror assembly, the shape of the mirror area usually equal to the shape of the mirror and the mirror area usually is located under the mirror assembly. Wherein, at least an element, such as lens, light sensor, and charger coupled device, is located inside the device area.

[0012] In this embodiment, the mirror assembly is mechanically connected with the element assembly. In fact, each assembly is formed and precisely amended before they are connected to form the whole optical carriage of scanner. Besides, to reduce the risk of deformation of both lens holders and supporters, the embodiment forms both lens holders and supporters by one or combination of the following: metal punch, plastic ejection, and plastic process.

BRIEF DESCRIPTION OF THE DRAWINGS

[0013] A more complete appreciation and many of the attendant advantages will be readily obtained as the same becomes better understood by reference to the following detailed description when considered in connection with the accompanying drawings.

[0014] FIG. 1A to FIG. 1C show the essential structure of one preferred embodiment of this invention; and

[0015] FIG. 2A to FIG. 2C show the essential flow-chart of another preferred embodiment of this invention.

DESCRIPTION OF THE PREFERRED EMBODIMENT

[0016] Regarding to the defects induced by the process that directly form the whole structure plastic ejection, and also regarding to the defects induced by the lack of separated amendment of the details, the invention solves the defects by a two-stage formation. In detail, the invention separately forms the mirror assembly and the element assembly without limiting how each assembly is formed, and then mechanically connects the mirror assembly with the element assembly. Thus, any defect induced by the plastic ejection could be prevented while the plastic ejection being replaced by other fabrication, and the details of each assembly could be separately amended during the formation of each assembly. Besides, because the mirror assembly and the element assembly do not share the same device for the conventional optical carriage of scanner, the two-stage formation of this

invention not only would not change the structure and corresponding position of the assemblies, but also would not induce any extra difficulty to align.

[0017] Regarding to the defects induced by the weak hardness and/or the weak rigidity of the plastic material, especially regarding to the defects of damages and deformation, the invention solves the defects by changing the used material and the used fabrication. In detail, the invention could form the supporters and the mirror holders, even could form the whole mirror assembly, by monoblock vast, the invention also could form the supporters and the mirror holder, even could form the whole mirror assembly, by one of the following: metal punch, plastic ejection, and plastic ejection with the mechanically enhanced structure.

[0018] One preferred embodiment of this invention is an optical carriage of scanner. As shown in FIG. 1A, FIG. 1B, and FIG. 1C, the embodiment at least has mirror assembly 11 and element assembly 12. Moreover, mirror assembly 11 at least has mirror mount 111, supporter 112, and lens holder 113, and element assembly 12 at least has chassis 121. Certainly, the case with three mirror 13 only is an example, the embodiment never limits the shape of both mirror mount 111 and chassis 121, also never limits the number, the shape and the location of mirror 13, still never limits the number, the shape, and the location of both supporters 111 and lens holder 112.

[0019] Significantly, mirror mount 111 is used to restrict the location and relative location of all mirrors 13 which are supported by mirror assembly 11. In the embodiment, all supporters 112 are located and protruded mirror mount 111, and each supporter 112 are separated from other supporters 112. Further, all mirror holders 113 also are located and protruded mirror mount 111, and each mirror holder 113 has two terminals where one terminal is directly connected with mirror mount 111 and another terminal is separated from mirror mount 111. Surely, the invention only requires that each mirror 13 is fixed in mirror mount 111 by at least two lens holder 113 which are not located on the same side of the mirror 13, and requires that each mirror 13 is supported on mirror mount 111 by at least three supporters 112. The reasons of this requirements are three points determine a plane and two points determine a line.

[0020] Further, element assembly 12 has chassis 121 which could be divided into separate device area 123 and mirror area 122. Wherein, mirror assembly 11 is located inside mirror area 122, and at least an element, such as lens, charger coupled device, light sensor, or integrated circuit, is located inside device area 123.

[0021] One main characteristic of this embodiment is that element assembly 12 are mechanically connected with mirror assembly 11 after they are formed separated, but not are formed with mirror assembly 11 as a whole at the same time. Wherein, the available mechanical connection between mirror assembly 11 and element assembly 12 is one or combination of the following: hook, insert, weld, adherence, hinge, and nail. Herein, because that the embodiment does not limit the details of the mechanical connection, all figures omit the used mechanical connection. However, it should be noted that the used mechanical connection should not damage or block the propagation of light between different mirrors 13 inside mirror assembly 11, also should not damage or block the propagation of light inside element assembly 12.

[0022] Further, to simplify the fabrication, the embodiment could form mirror assembly 11 by the monoblock cast. Moreover, to prevent deformation of supporters 112 and mirror holders 113, the embodiment could enhance the hardness and rigidity of both supporters 112 and mirror holders 113 by form mirror assembly 11 with one or combination of the following technologies: metal punch, plastic ejection, and plastic ejection with the mechanically enhanced structure.

[0023] Furthermore, while the shape of optical carriage of scanner let the conventional technologies can not precisely form required supporters 112 and mirror holders 113, the embodiment could replace the step of forming whole mirror assembly 11 with the use of monoblock vast by the step of forming both supporters 112 and mirror holders 113 with the use of monoblock vast to precisely amend the details of supporters 112 and mirror holders 113. Certainly, to prevent deformation of supporters 112 and mirror holders 113, the embodiment could enhance the hardness and rigidity of both supporters 112 and mirror holders 113 by form mirror assembly 11 with one or combination of the following technologies: metal punch, plastic ejection, and plastic ejection with the mechanically enhanced structure.

[0024] Besides, because mirror holders 113 are used to fixed mirrors 13 on mirror mount 111, the width of a gap between any mirror holder 112 and mirror mount 111 should be equal to or slightly less than the thickness of one mirror which is supported by the mirror holder 112. Surely, to easily insert and effectively hold mirror 13, mirror holders 113 usually are made of the elastic material.

[0025] Moreover, it should be emphasized that the main characteristic of this embodiment is that mirror assembly 11 and element assembly 12 are separately formed and connected by mechanical connection. In contrast, how mirror assembly, especial supporters 112 and mirror holders 113, is formed, what material is used, and what shape is formed only in some minor characteristics of the embodiment.

[0026] However, the invention is not limited by the embodiment. For example, while the shape of the optical carriage of scanner could be precisely formed by plastic ejection but mirror assembly 11, especial supporters 112 and mirror holders 113, is trend to be deformed during the operation of the optical carriage, the invention could only amend the formation and the material of mirror assembly 11, especial supporters 112 and mirror holders 113. In the case, the invention does not concern whether mirror assembly 11 and element assembly 12 is separated formed or formed by monoblock vast.

[0027] Another preferred embodiment is a method for forming the optical carriage of a scanner, especially for forming the preferred embodiment. As FIG. 2A shows, the embodiment at least has following essential steps:

[0028] As separately formation block 21 shows, separately form a mirror assembly and an element assembly. The mirror assembly at least has the mirror mount, the supporter, and the mirror holder. The element assembly at least has the chassis.

[0029] As mechanical connection block 22 shows, mechanically connect the mirror assembly with the element assembly.

[0030] In the embodiment, the available mechanical connection between the mirror assembly and the element assembly is one or combination of the following: hook, insert, weld, adherence, hinge, and nail. However, the embodiment does not limit the details of the mechanical connection.

[0031] In additional, the mirror mount is used to limit the location of each mirror and relative location of the different mirror, and both the supporters and the mirror holders are used to fix all mirrors in the predetermined location of the mirror mount. The chassis usually is divided into a device area and a mirror area, wherein mirror assembly is located inside the mirror device and at least an element is located inside the device area. However, the embodiment does not limit the details of both assemblies, no matter shape, material or fabrication.

[0032] For example, the embodiment could form the mirror assembly by the monoblock cast, or by one or combination of the followings: metal punch, plastic ejection and plastic process. For example, the embodiment could form both the supporters and the mirror holders by the monoblock cast, or by one or combination of the following: metal punch, plastic ejection and plastic process.

[0033] For example, the embodiment could but not need to let the supporters be located and protruded the mirror mount and let each supporter be separated from other supporters. For example, the embodiment could but not need to let the mirror holders be located and protruded the mirror mount and let each mirror holder has one terminal directly connected with the mirror mount and has another terminal separate from the mirror mount.

[0034] Besides, because that the optical carriage of scanner usually has at least one mirror, as FIG. 2B shows, the embodiment could perform mirror combination block to support at least one mirror by the mirror assembly before perform mechanical connection block 22 to mechanically connect the mirror assembly and the element assembly. Certainly, as FIG. 2C shows, the invention also perform mechanical connection block 22 to mechanically connect the mirror assembly and the element assembly before perform mirror combination block to support at least one mirror by the mirror assembly.

[0035] From the foregoing it will be appreciated that, although specific embodiments of the invention have been described herein for the purpose of illustration, various modifications may be made without deviating from the spirit and scope of the invention. Accordingly, the invention is not limited except as by the appended claims.

What is claimed is

1. An optical carriage of scanner, comprising:

a mirror assembly, comprising:

a mirror mount;

at least a supporter, said supporter being located and protruded said mirror mount, each said supporter being separated from other said supporters; and

at least a mirror holder, said mirror holders being located in and protruded said mirror mount, each said mirror holder having two terminals where one

terminal is connected with said mirror mount and another terminal is separated from said mirror mount; and

an element assembly, said element assembly being mechanically connected with said mirror assembly, comprising:

a chassis, said chassis being divided into a device area and a mirror area, wherein said mirror assembly is located inside said mirror device and said at least an element is located inside said device area.

2. The optical carriage of claim 1, the available mechanical connection between said mirror assembly and said element assembly is chosen from the group consisting of hook, insert, weld, adherence, hinge, and nail.

3. The optical carriage of claim 1, said mirror assembly being formed by the monoblock cast.

4. The optical carriage of claim 1, said mirror assembly being formed by the metal punch.

5. The optical carriage of claim 1, said mirror assembly being formed by the plastic ejection.

6. The optical carriage of claim 1, said mirror assembly being formed by the plastic ejection with the mechanically enhanced structure.

7. The optical carriage of claim 1, said supporters and said mirror holders are formed by the monoblock cast.

8. The optical carriage of claim 1, said supporters and said mirror holders are formed together by the metal punch.

9. The optical carriage of claim 1, said supporters and said mirror holders are formed together by the plastic ejection.

10. The optical carriage of claim 1, said supporters and said mirror holders are formed together by the plastic ejection with the mechanically enhanced structure.

11. The optical carriages of claim 1, the width of a gap between one specific said mirror holder and said mirror mount being equal to the thickness of one said mirror which is supported by the specific said mirror holder.

12. The optical carriage of claim 1, each mirror which is supported by said mirror assembly being supported by three said supporters which are not located in one same line.

13. The optical carriage of claim 1, each mirror which is supported by said mirror assembly being supported by two said supporters which are not located on the same side of said mirror.

14. The optical carriage of claim 1, said mirror holders being made of the elastic material.

15. A mirror carriage, comprising:

a mirror mount;

at least a supporter, said supporter being located and protruded said mirror mount, each said supporter being separated from other said supporters; and

at least a mirror holder, said mirror holders being located and protruded said mirror mount, each said mirror holder having two terminals where one terminal is directly connected with said mirror mount and another terminal is separated from said mirror mount.

16. The mirror carriage of claim 15, said mirror mount, said supporters and said mirror holders being formed by the monoblock cast.

17. The mirror carriage of claim 15, said mirror mount, said supporters and said mirror holders being formed by the metal punch.

18. The mirror carriage of claim 15, said mirror mount, said supporters and said mirror holders being formed by the plastic ejection.

19. The mirror carriage of claim 15, said mirror mount, said supporters and said mirror holders being formed by the plastic ejection with the mechanically enhanced structure.

20. The mirror carriage of claim 15, said supporters and said mirror holders are formed by the monoblock cast.

21. The mirror carriage of claim 15, said supporters and said mirror holders are formed together by the metal punch.

22. The mirror carriage of claim 15, said supporters and said mirror holders are formed together by the plastic ejection.

23. The mirror carriage of claim 15, said supporters and said mirror holders are formed together by the plastic ejection with the mechanically enhanced structure.

24. A method for forming the optical carriage of a scanner, comprising:

separately forming a mirror assembly and an element assembly, said mirror assembly comprising a mirror mount, at least a supporter, and a mirror holder, said element assembly comprising a chassis; and

mechanically connecting said mirror assembly with said element assembly.

25. The method of claim 24, the available mechanical connection between said mirror assembly and said element assembly is chosen from the group consisting of hook, insert, weld, adherence, hinge, and nail.

26. The method of claim 24, further comprising the step of forming said mirror assembly by the monoblock cast.

27. The method of claim 24, further comprising the step of forming said mirror assembly by one of the following: metal punch, plastic ejection and plastic process.

28. The method of claim 24, further comprising the step of forming both said supporters and said mirror holders by the monoblock cast.

29. The method of claim 24, further comprising the step of forming both said supporters and said mirror holders by one of the following: metal punch, plastic ejection and plastic process.

30. The method of claim 24, further comprising the step of supporting at least a mirror by said mirror assembly before said mirror assembly and said element assembly being mechanically connected.

31. The method of claim 24, further comprising the step of supporting at least a mirror by said mirror assembly after said mirror assembly and said element assembly being mechanically connected.

32. The method of claim 24, each said supporters not only being located and protruded said mirror mount but also being separated from other said supporters.

33. The method of claim 24, each said mirror holders not only being located in and protruded said mirror mount but also having two terminals where one terminal is connected with said mirror mount and another terminal is separated from said mirror mount.

34. The method of claim 24, said chassis being divided into a device area and a mirror device, wherein said mirror assembly is located inside said mirror device and said at least an element is located inside said device area.

* * * * *