



US 20060043230A1

(19) **United States**

(12) **Patent Application Publication**
Jenrick

(10) **Pub. No.: US 2006/0043230 A1**

(43) **Pub. Date: Mar. 2, 2006**

(54) **PAPER GUIDE APPARATUS AND METHOD WITH CURL CONTROL**

Publication Classification

(75) **Inventor: Paul W. Jenrick, Schaumburg, IL (US)**

(51) **Int. Cl.**
B65H 23/00 (2006.01)

(52) **U.S. Cl.** **242/566**

Correspondence Address:
BAKER & HOSTETLER LLP
Washington Square
Suite 1100
1050 Connecticut Avenue, N.W.
WASHINGTON, DC 20036 (US)

(57) **ABSTRACT**

A paper guide for mounting in front of a paper dispensing slot, has a top wall angled downward with respect to the paper ejection direction by an angle alpha, a pair of opposed side walls at the sides of the top wall, angled inwardly relative to the side edges of the paper by the an angle beta, and also angled inwardly with respect to a line perpendicular to the rear edge of the top wall by an angled gamma, and a pair of mounting tabs, each respective mounting tab extending from a respective side wall for attachment against the paper dispensing device.

(73) **Assignee: General Signal Technology Corporation**

(21) **Appl. No.: 10/923,773**

(22) **Filed: Aug. 24, 2004**

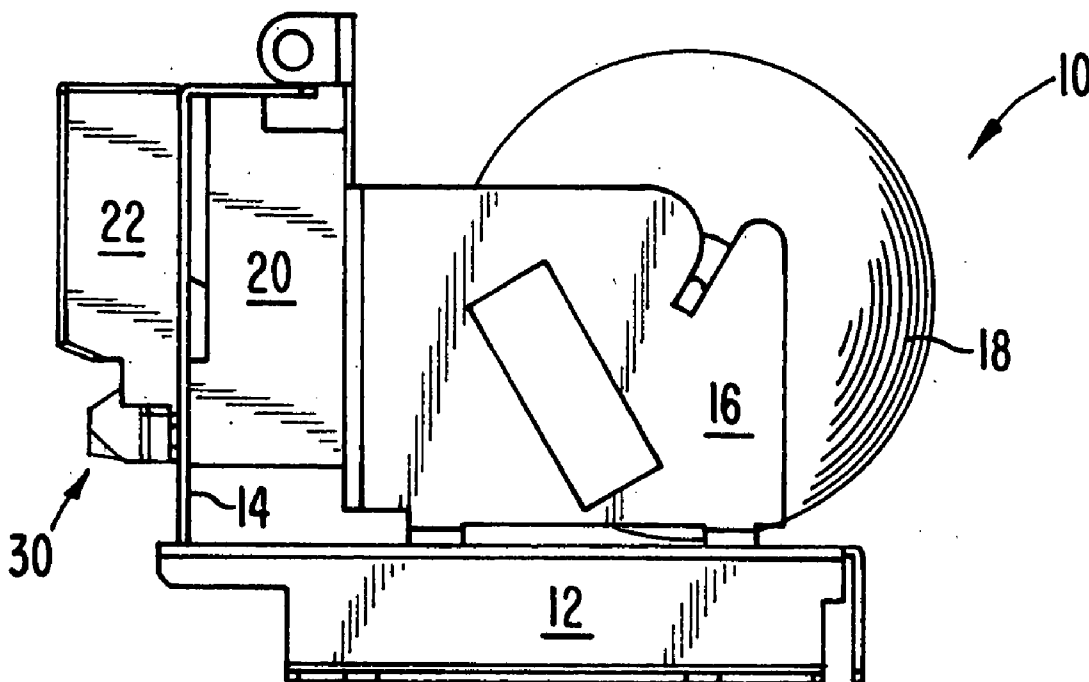

FIG. 1

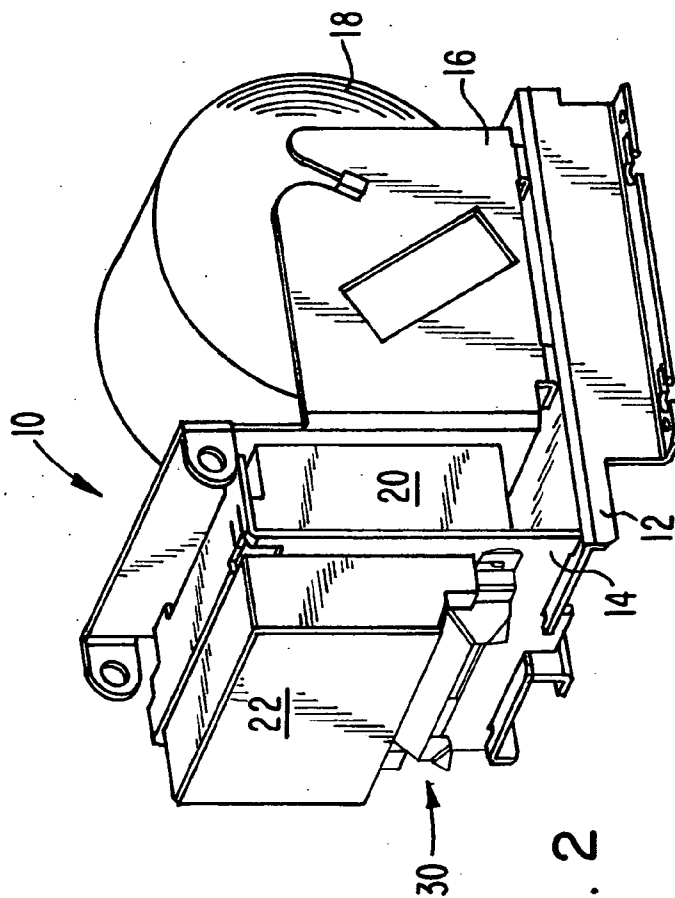
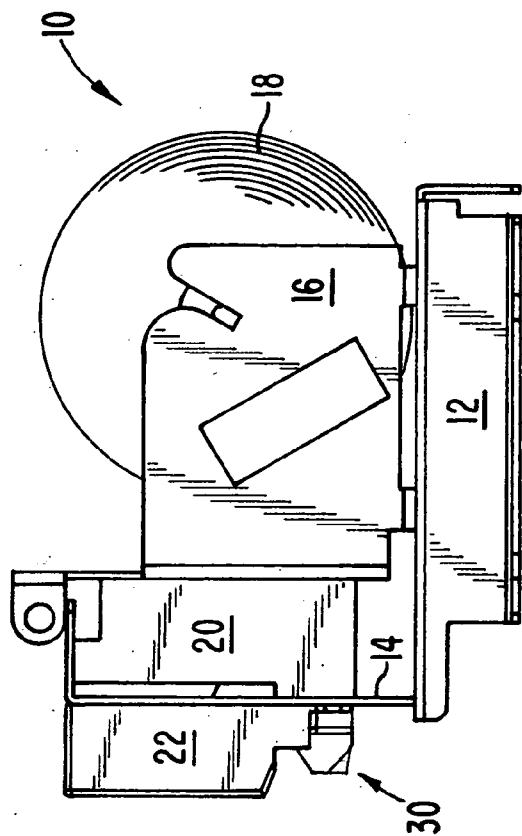

FIG. 2

FIG. 5

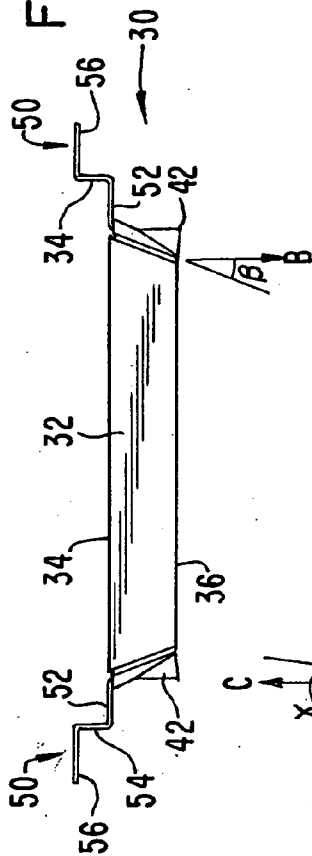

FIG. 4

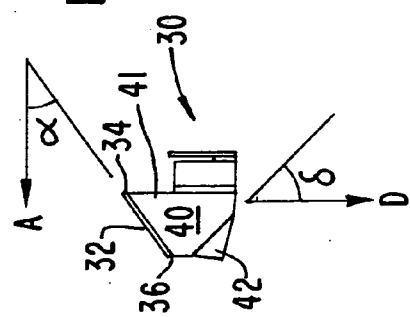

FIG. 6

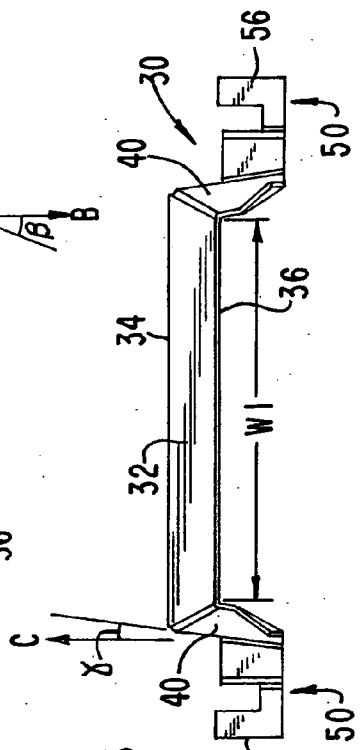

FIG. 3

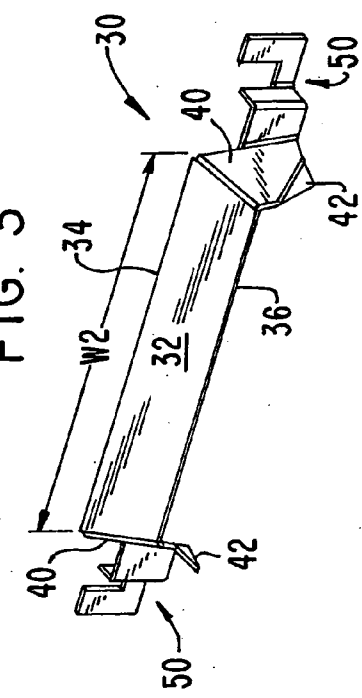

FIG. 7

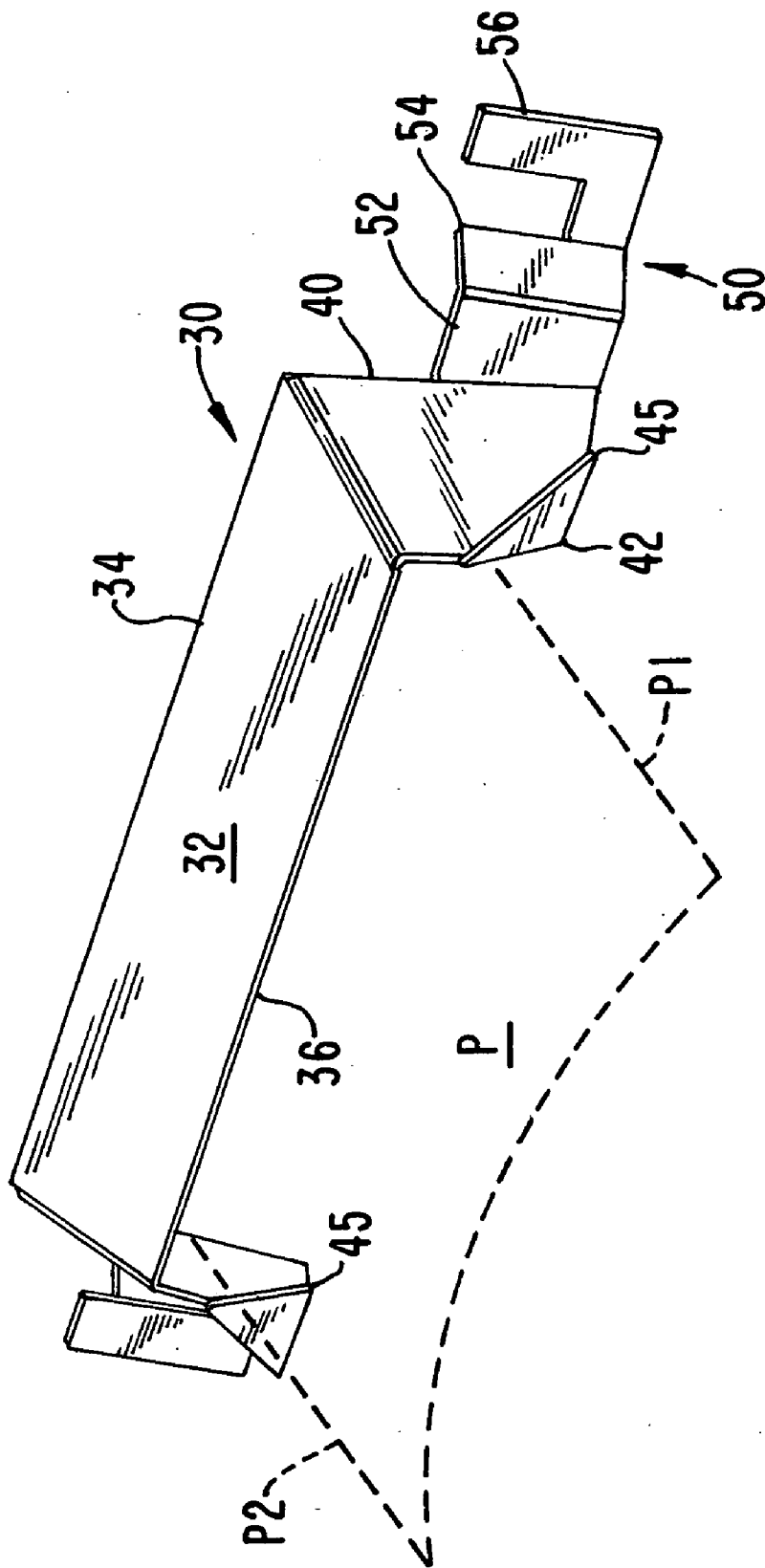

FIG. 8

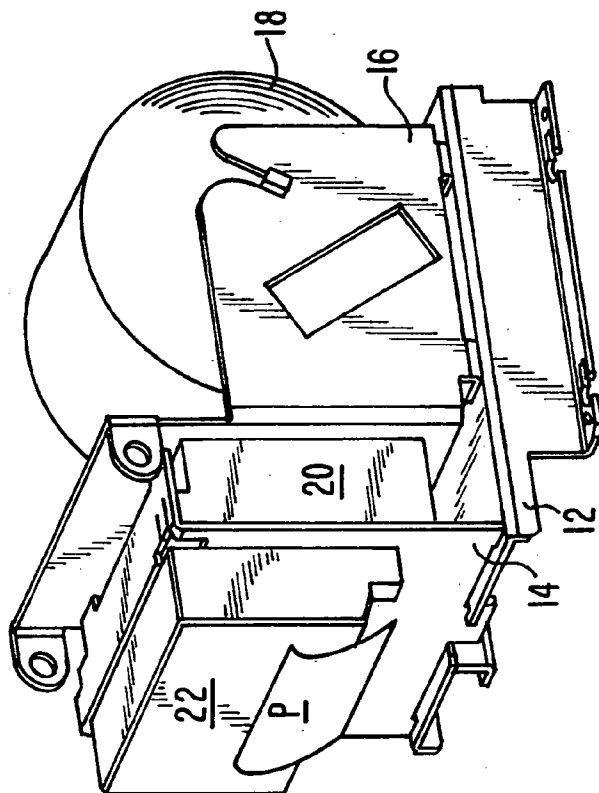
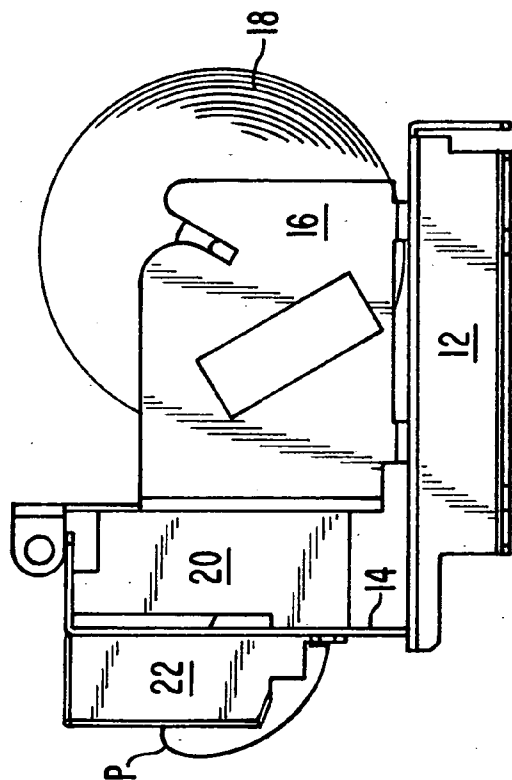

FIG. 9

PAPER GUIDE APPARATUS AND METHOD WITH CURL CONTROL

FIELD OF THE INVENTION

[0001] The invention pertains to the field of dispensing paper from a roll. More particularly, the invention relates to the field of dispensing paper from the roll through an outlet dispensing slot so that it can be removed by a user.

BACKGROUND OF THE INVENTION

[0002] Paper dispensers are in wide use in the industry. One example of such use is the dispensing of tickets, which may be for example receipts for a purchase from a vending machine or tickets that are used to gain access to an event or to a transportation system. In some instances, it is known to dispense individual tickets using a system that has a roll of paper and feeds the paper from the roll past a printing element and past a dispensing slot or an outlet of some sort of cutting element so that the amount of paper sticking out of the slot or outlet is available to the user so the user, and can grab the extended paper with his or her hand and remove it.

[0003] In some instances, the piece of paper from the roll that is extending out of the dispenser slot will be cut by an automatic blade arrangement that is between the feed rollers and the dispensing slot, and some form of frictional resistance such as an additional set of rollers will provide a small amount of friction to hold the paper in place extending out of the slot until the frictional resistance is overcome by the user pulling the paper out of the slot. In other known devices, the piece of paper extending out of the slot will still be attached to the roll and some form of manual cutter such as a serrated blade edge is present near the slot and when the user removes the piece of paper, the user is pulling the paper against the serrated blade which will tear off the paper at the blade location.

[0004] Various types of roll paper are in use in such known commercial paper ticket dispensers. The paper may be plain paper which is printed on by inks by a dot matrix or ink jet printer, or in some instances may be thermal paper which is printed on by a heat-applying print head.

[0005] A disadvantage of the above described systems is that in either instance, the paper often tends to curl up as it extends out to the dispensing slot. The paper curl problem can usually be due to one or more of several factors. First, the paper is initially being dispensed from a roll, and hence tends to have some degree of curl present from the time spent on the roll. This curl problem tends to be most severe with paper towards the end of the roll, which is most tightly wound around the core. Further, the pressure or heat applied by the print head onto one side of the paper while not on the other side of the paper can also tend to cause the paper to curl, and in many instances, both of these curling effects operate in the same direction on the paper thus reinforcing the curl.

[0006] As a result of these curling tendencies, paper which is simply ejected through a rectangular slot will often tend to curl back towards the slot to some degree. This can be undesirable for several reasons. Severe roll-curling can cause the paper to miss the dispensing slot. In some examples, this level of problem can begin to occur when the

roll is used down to $\frac{1}{3}$ of its diameter. Also, when the user removes the piece of paper, the user is left with a curled piece, which may be aesthetically unappealing and also not convenient to carry in a pocket or fold. Further, the curled paper may tend to curl vertically upwards for example and hug the front housing of the dispensing device, making it somewhat more difficult to grasp for removal than if it were sticking roughly straight out from the dispensing device. Finally, the curled paper while curled in one direction is substantially flat in the other direction. As a result, the paper may be susceptible to flopping in the wind, or in the case of strong winds even being blown out of the dispenser before the user has a chance to remove it.

[0007] The curling problem can also be more severe in the case of thermal printed paper. The coated side of the paper may tend to curl when printed, further reinforcing the curl.

[0008] Accordingly, there is a need in the art for a paper guide that can overcome the above curled paper disadvantages at least to some extent.

SUMMARY OF THE INVENTION

[0009] The foregoing needs are met, to a great extent, by the present invention, wherein in one aspect an apparatus is provided that in some embodiments a paper guide for mounting in front of a paper dispensing slot of a paper dispensing device that dispenses paper in a paper ejection direction, the guide comprising a top wall angled downward with respect to the paper ejection direction by an angle α , a pair of opposed side walls at the sides of the top wall, angled inwardly relative to the side edges of the paper by the angle β , and also angled inwardly with respect to a line perpendicular to the rear edge of the top wall by an angle γ , and a pair of mounting tabs, each respective mounting tab extending from a respective side wall for attachment against the paper dispensing device.

[0010] In accordance with one embodiment of the present invention, a paper guide for mounting in front of a paper dispensing slot of a paper dispensing device that dispenses paper in a paper ejection direction, the guide comprising a top paper guiding means angled downward with respect to the paper ejection direction by an angle α , a pair of opposed side walls at the sides of the top wall, angled inwardly relative to the side edges of the paper by the angle β , and also angled inwardly with respect to a line perpendicular to the rear edge of the top wall by an angle γ , and mounting means for mounting the guide against the paper dispensing device.

[0011] In accordance with another embodiment of the present invention a method for dispensing paper in a paper dispensing direction from a paper dispensing device, comprising feeding paper through a dispensing slot, and guiding the paper via a paper guide having, a top wall angled downward with respect to the paper ejection direction by an angle α , a pair of opposed side walls at the sides of the top wall, angled inwardly relative to the side edges of the paper by the angle β , and also angled inwardly with respect to a line perpendicular to the rear edge of the top wall by an angle γ , and a pair of mounting tabs, each respective mounting tab extending from a respective side wall for attachment against the paper dispensing device.

[0012] There has thus been outlined, rather broadly, certain embodiments of the invention in order that the detailed

description thereof herein may be better understood, and in order that the present contribution to the art may be better appreciated. There are, of course, additional embodiments of the invention that will be described below and which will form the subject matter of the claims appended hereto.

[0013] In this respect, before explaining at least one embodiment of the invention in detail, it is to be understood that the invention is not limited in its application to the details of construction and to the arrangements of the components set forth in the following description or illustrated in the drawings. The invention is capable of embodiments in addition to those described and of being practiced and carried out in various ways. Also, it is to be understood that the phraseology and terminology employed herein, as well as the abstract, are for the purpose of description and should not be regarded as limiting.

[0014] As such, those skilled in the art will appreciate that the conception upon which this disclosure is based may readily be utilized as a basis for the designing of other structures, methods and systems for carrying out the several purposes of the present invention. It is important, therefore, that the claims be regarded as including such equivalent constructions insofar as they do not depart from the spirit and scope of the present invention.

BRIEF DESCRIPTION OF THE DRAWINGS

[0015] FIG. 1 is a side layout view of a paper dispensing apparatus having a paper guide according to a preferred embodiment of the present invention.

[0016] FIG. 2 is a perspective view of the apparatus of FIG. 1.

[0017] FIG. 3 is a perspective view of a paper guide used in the apparatus of FIG. 1.

[0018] FIG. 4 is a side view of the paper guide.

[0019] FIG. 5 is a top view of the paper guide.

[0020] FIG. 6 is a front view of the paper guide.

[0021] FIG. 7 is a perspective view of the paper guide showing a piece of dispensed paper.

[0022] FIG. 8 is a side layout view of a paper dispensing apparatus dispensing paper with the paper guide omitted.

[0023] FIG. 9 is a perspective view of the paper dispensing apparatus dispensing paper with the paper guide omitted as in FIG. 8.

DETAILED DESCRIPTION

[0024] Preferred embodiments of the invention will now be described with reference to the drawing figures, in which like reference numerals refer to like parts throughout. FIGS. 1 and 2 illustrate a paper dispensing apparatus 10 which has a base or frame 12 supporting a paper holder 16. The paper holder 16 supports a roll of paper 18. The frame 12 also supports a front mounting plate 14 which supports paper processing items 20 and 22. Item 20 may be for example, a printing device which may print onto thermal heat head, or may print onto conventional paper using a dot matrix and a ribbon or an ink jet print head. Item 22 may for example be a paper cutter which cuts off the paper after a certain amount has been dispensed through an outlet slot, but also has a

frictional retaining means to retain the cut piece of paper until it is removed by the user. One or both of items 20 and 22 may include paper feeding rollers.

[0025] A paper outlet slot (not visible) is located just behind a paper guide 30. The paper guide 30 is mounted just in front of, i.e., outside of, the paper ejection slot. In the illustrated example, the printing assembly 20 is a thermal printer mounted to the rear of the front mounting plate 14. The paper is ejected from the printer 20 through a slot in the mounting plate 14. An automatic cutter 22 is mounted to the front of the mounting plate 14 and cuts off the paper. The printing assembly 20 and cutting assembly 22 may each have appropriate feeding rollers which grasp the paper from the top and/or the bottom and feed the paper forward and out through the slot including during the printing process. In some instances, an automatic cutter blade may not be provided, and instead a static cutter blade may be provided near the slot so that as the user pulls on the rejected paper, the paper is cut or torn by the force provided by the user at a location near the slot.

[0026] The paper guide 30 provides a significant advantage of the invention by reducing curl of the ejected paper that could otherwise occur. For example, FIGS. 8 and 9 show a ticket dispensing assembly similar to that of FIGS. 1 and 2 but with the paper guide 30 omitted. FIGS. 8 and 9 illustrate the problem that can occur with a slot dispenser that does not have a paper guide, because the paper P tends to curl upwards as shown. The situation shown in FIGS. 8 and 9 can be undesirable for many reasons, including the paper being hard to grasp for removal, the paper being curled even after removal, and/or the paper having a tendency to flap in the wind or be blown from the slot.

[0027] The paper guide 30 can overcome these problems at least to a great extent. Turning to FIGS. 3-6, it will be appreciated that the paper guide 30 has a top wall 32, which has a rear edge 34 and a front edge 36, and two side walls 40 each having a respective ear 42. Respective side tabs 50 each have a front portion 52 and an intermediate portion 54 and a rear portion 56 which is adapted to be mounted against the front mounting plate 14 of the paper dispensing assembly. An immediate portion 54 offsets the rear edge 34 from the plane of the mounting tabs 56 to provide a clearance for a cutting arrangement which is the lower part of the cutting assembly 22. The mounting tabs 50 provide the mounting of the paper guide so it is in front of the outlet slot through which the piece of paper is ejected.

[0028] Referring now to FIG. 4, it can be seen that the top wall 32 is at an angle α to the illustrated direction A. Direction A is a direction which is substantially the direction of ejection of the paper through the slot and is also a direction substantially perpendicular to edge 41 which is the rear edge of the sidewall 40. Typically, direction A will be a horizontal direction and rear edge 41 will be oriented in a vertical direction D which is parallel to the plane in which the front mounting plate 14 extends.

[0029] Turning to FIG. 5, the side walls 40 are each angled by a angle β relative to direction B, which B is perpendicular to the rear edge 34 of the top wall 32, and is also referred to as to the forward paper rejection direction.

[0030] Turning to FIG. 6, the side walls 40 are also angled by angle γ relative to direction C which is a direction

perpendicular to the rear edge **34** and parallel to the rear edge **41**, and which typically will be an upward direction that is perpendicular to the direction of ejection of the paper, roughly parallel to the direction of the mounting plate **14**. Referenced directions A, B, and C are each perpendicular to each other and that form a coordinate axis set.

[0031] Turning to **FIGS. 3 and 6** in particular, it can be seen that the rear edge **34** of the top wall **32** has a width **W2** and the front edge **36** has a width **W1**. Thus, the overall paper guide defined by top wall **32** and side walls **40** can be said to be tapering both in a downward direction and in a converging direction as the paper is ejected along it. Edge **42** is far out at the front and lower corners of the side walls **40** to provide a somewhat smooth corner, as opposed to a rough edge for supporting the sides of the ejected paper, as discussed in more detail below.

[0032] **FIG. 7** illustrates the paper being bent somewhat downwardly in an arc so that its edges **P1** and **P2** are each in contact with a corner **45** which is formed at the junction of the side wall **40** and the ear **42**. In an alternative embodiment, the ears **42** can be omitted, and in such an embodiment the location of the bend **45** would simply be an open edge. Such an embodiment would function substantially similarly, that the provision of the ears **42** provides for the bend **45** to be a relatively smooth metal surface rather, than a relatively sharp edge, and thus presents less resistance to the paper sliding out of the guide. The ear **42** meets the side wall **40** at an angle δ relative to reference line B as shown in **FIG. 4**, where D is again the vertical line associated with the rear wall **41** and the front mounting plate **14**.

[0033] In one preferred embodiment, the paper width is 2.281 inches, the width **W1** is 2.214 inches and the width **W2** is 2.50 inches. In this preferred embodiment, the angle α is 30 degrees, the angle β is 20 degrees and the angle γ is β degrees, and the angle δ is 45 degrees.

[0034] Turning now to **FIG. 7**, the operation of the paper guide **30** is shown wherein a sample piece of paper P is shown extending from the paper guide **30**. It can be seen that rather than curling upwards as in **FIGS. 8 and 9**, in **FIG. 7** the paper in general extends straight outwards, while having a very slight curve from side to side, as opposed to end to end. The imparting of this side to side curve is significant enough to resist upward or downward curling and also may in some circumstances impart a very small stress bend to the paper which causes it to resist curling in the end to end direction even after it is removed to some extent. The ears **42** bend away from the wall **40** at a 40 to 30 degree angle measured directly between their respective planes with an angle δ of 45 degrees. Therefore, the ear **42**, in addition to providing a smooth edge as described above also provides (1) a stronger degree of side to side curvature when the paper is near the end of the roll (i.e. when it tends to inherently have more upward end to end curl) and (2) a lesser amount of side to side curvature when the paper is at the beginning of the roll. Thus, as the curl becomes more severe at the smaller radii of paper, the paper is forced up and in contact with edge **36** at which location the strongest side to side curve is imparted.

[0035] In the illustrated example, the printer **22** is thermal printer and the paper is coated thermal paper, which the printer **22** prints on by making dots with discharge arcs. The guide **30** also resists curl that is imparted by the printing process.

[0036] It will be appreciated that the result obtained in **FIG. 7** makes the paper easier to grasp since substantially all of its length is extending directly outward from the dispensing slot. The result also makes the paper more resistant to being blown by the wind, since it is supported not only behind the dispensing slot, but also by its contact with the side walls **40** outside the dispensing slot, but also by its contact with the side walls **40** outside the dispensing slot. The result of **FIG. 7** may in turn also result in some instances in a paper with less permanent curl even after it is removed.

[0037] Another advantage of the paper guide **30**, is that it is readily manufactured from a single piece of sheet metal by cutting an appropriate blank sheet and then folding it. In addition to reducing paper curl, the paper guide also serves to some extent as a roof or hood over the paper dispensing slot, and thus can also have the benefit of protecting the slot at least to some extent from the elements including rain or settling dust.

[0038] The many features and advantages of the invention are apparent from the detailed specification, and thus, it is intended by the appended claims to cover all such features and advantages of the invention which fall within the true spirit and scope of the invention. Further, since numerous modifications and variations will readily occur to those skilled in the art, it is not desired to limit the invention to the exact construction and operation illustrated and described, and accordingly, all suitable modifications and equivalents may be resorted to, falling within the scope of the invention.

What is claimed is:

1. A paper guide for mounting in front of a paper dispensing slot of a paper dispensing device that dispenses paper in a paper ejection direction, the guide comprising:

a top wall angled downward with respect to the paper ejection direction by an angle α ;

a pair of opposed side walls at the sides of the top wall, angled inwardly relative to the side edges of the paper by the an angle β , and also angled inwardly with respect to a line perpendicular to the rear edge of the top wall by an angle γ ; and

a pair of mounting tabs, each respective mounting tab extending from a respective side wall for attachment against the paper dispensing device.

2. The guide of claim 1, further comprising a pair of ears, wherein each respective ear extends from a forward part of a respective side wall, at an angle δ to the respective side wall.

3. The guide of claim 1, wherein the angle α is 30 degrees.

4. The guide of claim 1, wherein the angle β is 20 degrees.

5. The guide of claim 1, wherein the angle γ is 8 degrees.

6. The guide of claim 1, wherein the top wall has a rear edge having a rear edge width greater than the width of the dispensed paper, and a front edge having a front edge width less than the width of the paper.

7. The guide of claim 1, wherein the side walls each have a respective rear edge defining a side wall rear edge spacing between the side walls which is greater than the width of the dispensed paper, and wherein the rear walls together have front edges that are spaced apart by a front edge width that is less than the width of the paper.

8. A paper guide for mounting in front of a paper dispensing slot of a paper dispensing device that dispenses paper in a paper ejection direction, the guide comprising:

a top paper guiding means angled downward with respect to the paper ejection direction by an angle α ;

a pair of opposed side walls at the sides of the top wall, angled inwardly relative to the side edges of the paper by the an angle β , and also angled inwardly with respect to a line perpendicular to the rear edge of the top wall by an angle γ ; and

mounting means for mounting the guide against the paper dispensing device.

9. The guide of claim 8, further comprising a pair of ears, wherein each respective ear extends from a forward part of a respective side wall, at an angle δ to the respective side wall.

10. The guide of claim 8, wherein the angle α is 30 degrees.

11. The guide of claim 8, wherein the angle β is 20 degrees.

12. The guide of claim 8, wherein the angle γ is 8 degrees.

13. The guide of claim 8, wherein the top paper guiding means has a rear edge having a rear edge width greater than the width of the dispensed paper, and a front edge having a front edge width less than the width of the paper.

14. The guide of claim 8, wherein the side walls each have a respective rear edge defining a side wall rear edge spacing between the side walls which is greater than the width of the dispensed paper, and wherein the rear walls together have front edges that form a front edge width that is less than the width of the paper.

15. A method for dispensing paper in a paper dispensing direction from a paper dispensing device, comprising:

feeding paper through a dispensing slot; and

guiding the paper via a paper guide having;

a top wall angled downward with respect to the paper ejection direction by an angle α ;

a pair of opposed side walls at the sides of the top wall, angled inwardly relative to the side edges of the paper by the an angle β , and also angled inwardly with respect to a line perpendicular to the rear edge of the top wall by an angle γ ; and

a pair of mounting tabs, each respective mounting tab extending from a respective side wall for attachment against the paper dispensing device.

16. The method of claim 15, wherein the guide further comprises a pair of ears, wherein each respective ear extends from a forward part of a respective side wall, at an angle δ to the respective side wall.

17. The method of claim 15, wherein the angle α is 30 degrees.

18. The method of claim 15, wherein the angle β is 20 degrees.

19. The method of claim 15, wherein the angle γ is 8 degrees.

20. The method of claim 15, wherein the top wall has a rear edge having a rear edge width greater than the width of the dispensed paper, and a front edge having a front edge width less than the width of the paper.

* * * * *