



US 20070031960A1

(19) **United States**

(12) **Patent Application Publication**
Dosmann

(10) **Pub. No.: US 2007/0031960 A1**

(43) **Pub. Date: Feb. 8, 2007**

(54) **OPTICAL CUVETTE WITH
PLATFORM-AND-WELL CONSTRUCTION**

Related U.S. Application Data

(60) Provisional application No. 60/515,338, filed on Oct. 30, 2003.

(76) Inventor: **Andrew J. Dosmann**, Cranger, IN (US)

Publication Classification

Correspondence Address:
BAYER HEALTHCARE, LLC
1884 MILES AVENUE
P.O. BOX 70
ELKHART, IN 46515-0070 (US)

(51) **Int. Cl.**
C12M 1/34 (2006.01)
C12M 3/00 (2006.01)
(52) **U.S. Cl.** **435/287.2**

(57) **ABSTRACT**

(21) Appl. No.: **10/576,993**
(22) PCT Filed: **Oct. 29, 2004**
(86) PCT No.: **PCT/US04/36330**
§ 371(c)(1),
(2), (4) Date: **Apr. 25, 2006**

Formats for optical analysis of fluid samples are provided with platforms and wells for contacting fluid samples and bringing reagents in contact with fluid samples. Formats may be made in opposing platform-and-well constructions, allowing a platform protruding from one format member to enter a well contained within an opposing format member. A sample fill nose accepts sample fluid from a sample collection opening and transports the sample fluid through the format.

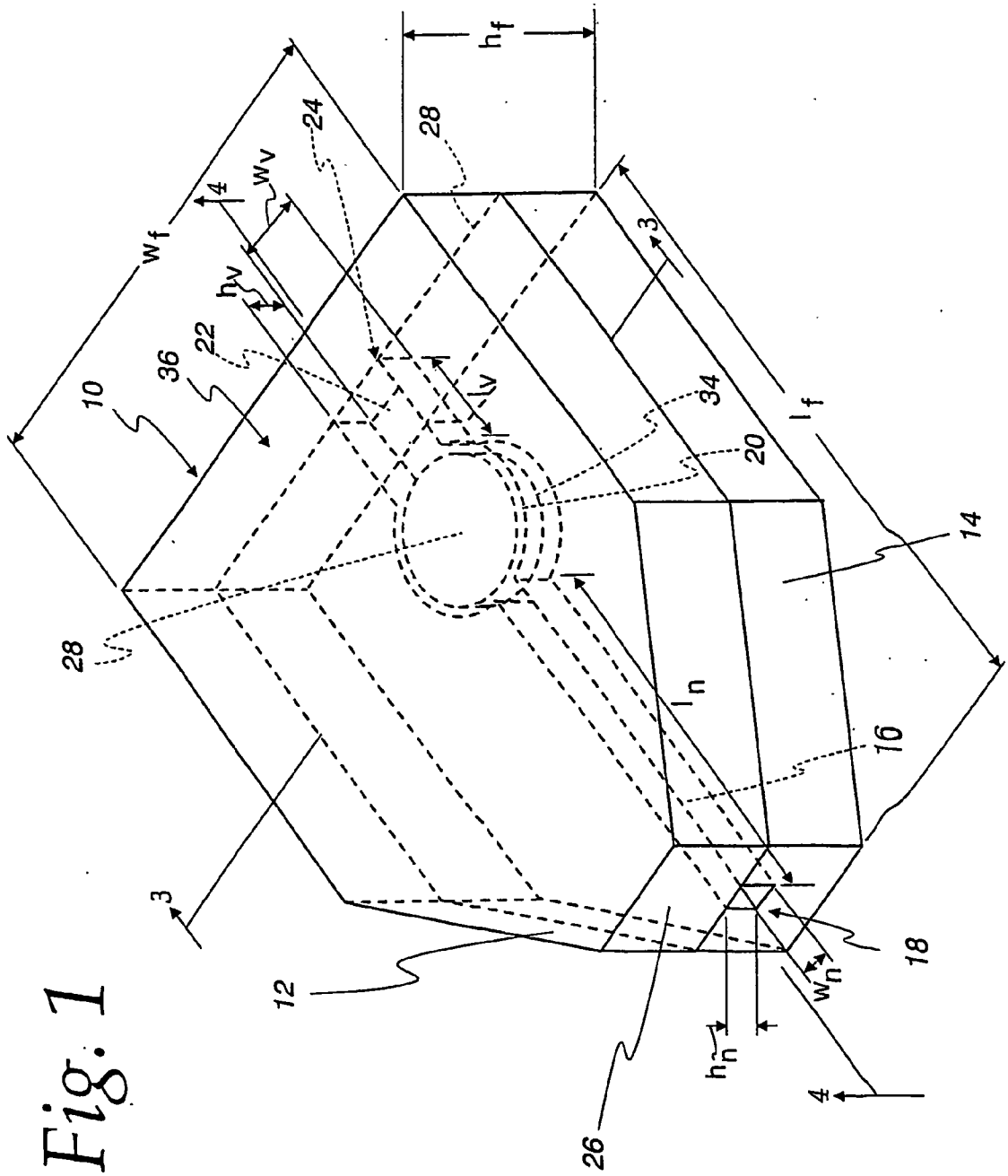

Fig. 1

Fig. 2

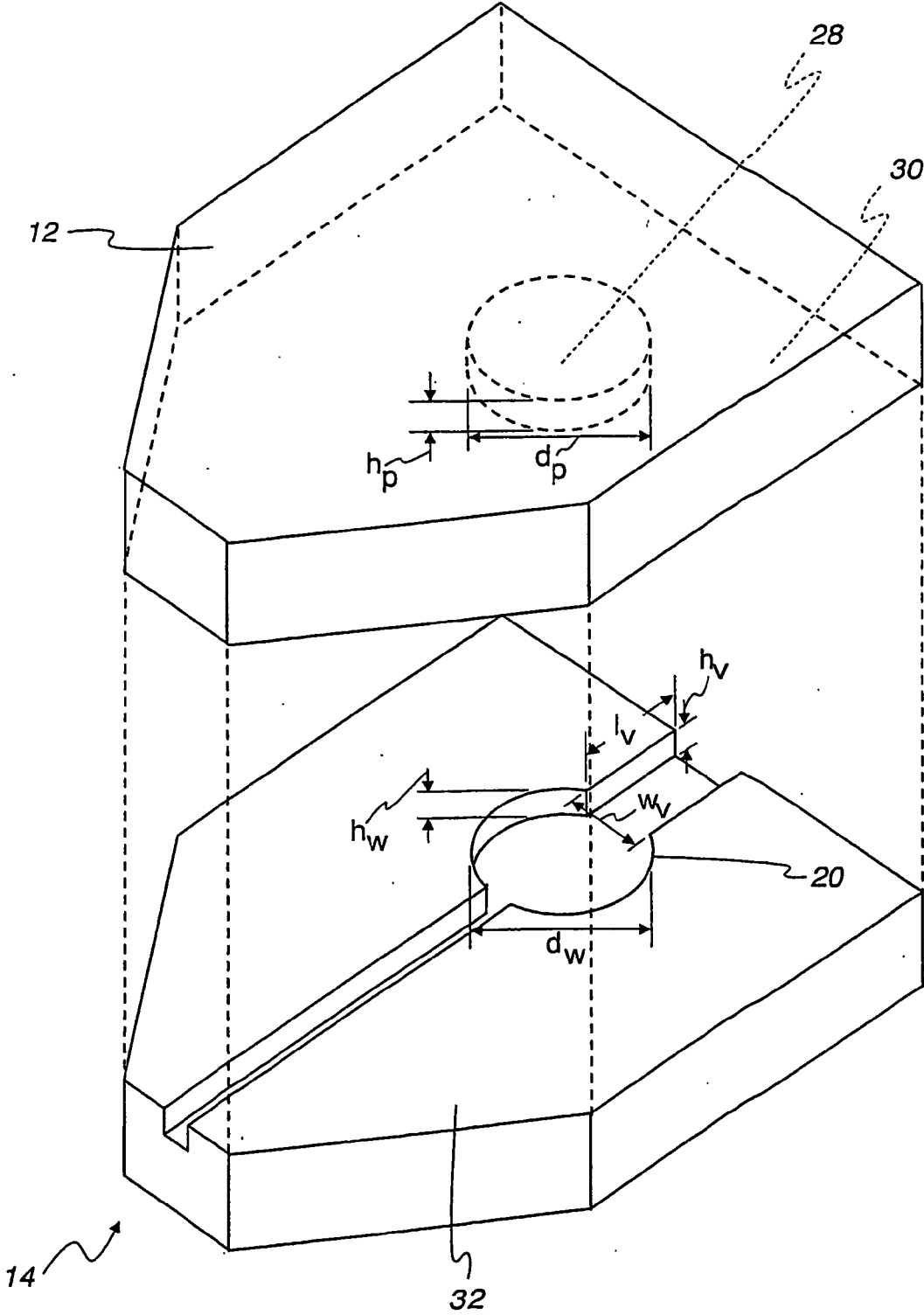

Fig. 3

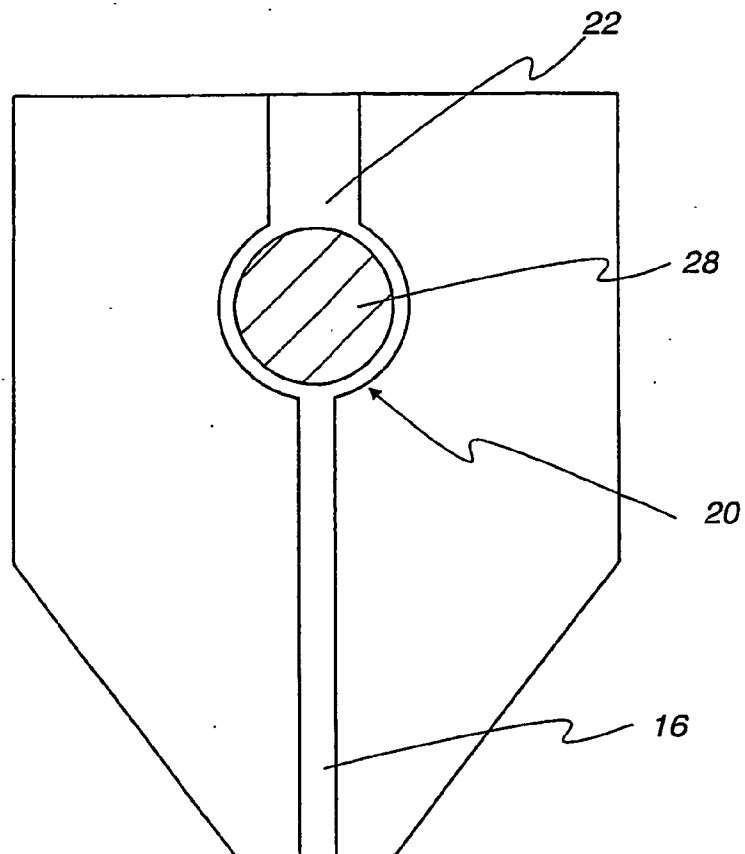
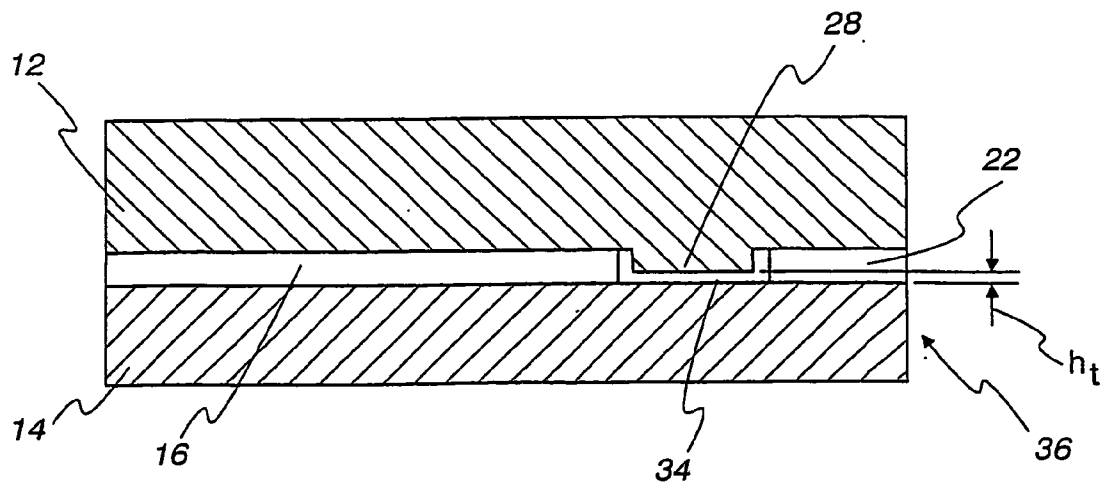

Fig. 4



OPTICAL CUVETTE WITH PLATFORM-AND-WELL CONSTRUCTION

FIELD OF THE INVENTION

[0001] The present invention relates generally to electrochemical analysis and more specifically to an optical format for fluid analysis.

BACKGROUND OF THE INVENTION

[0002] Optical testing of samples has become increasingly popular in recent years due to the speed, accuracy, and efficiency with which test results can be acquired through optical testing. Because of these benefits, optical testing is commonly used in medical applications such as glucose testing, with the sample fluid being blood. Generally, optical testing in medical applications involves allowing light to interact with a sample. In some applications, the sample may be combined with a reagent for testing. Optical testing may be accomplished using “formats,” which allow for the collection of a sample, combination of the sample with a reagent, and optical testing of the sample.

[0003] Several problems arise in optical testing applications. A common problem with sample testing is the necessary sample size to allow reaction with a reagent and enable accurate testing. Many optical formats require sample sizes of 300 nl or greater. Further, optical formats often result in performance errors due to poor mechanical tolerances of the formats. When a reagent is used with an optical format, the reagent may be inconsistently placed within the format. For example, an improper amount of reagent or reagent placed in the wrong location may affect test accuracy. Formats resulting in improper control of sample volume—for example, deposition of an insufficient sample volume within a test area—decrease the accuracy of many prior art optical testing systems. Further, the costs of manufacturing optical formats can be high, and resulting formats are often larger than desired.

[0004] In order to increase the efficiency and accuracy of optical sample testing, it is desirable to provide an improved optical format.

SUMMARY OF THE INVENTION

[0005] According to one embodiment of the present invention, an optical format allows a very small sample volume to result in accurate optical testing.

[0006] According to some embodiments of the present invention, an optical format is provided which allows accurate optical testing of sample volumes of approximately 50 nl.

[0007] According to some embodiments of the present invention, an optical format consists of two pieces designed to join into a single format allowing accurate testing of small optical volumes.

[0008] According to some embodiments of the present invention, optical formats allow the consistent placing of reagent within the optical format.

[0009] According to some embodiments of the present invention, reagent placement is facilitated by the use of a mesa upon which a reagent is placed during manufacturing of the format.

[0010] According to some embodiments of the present invention, sample volume is metered to a required amount within an optical format before the sample is allowed to react with a reagent within the optical format.

[0011] According to some embodiments of the present invention, an optical format is manufactured using continuous web processing to enable high-speed production of optical formats at low cost.

BRIEF DESCRIPTION OF THE DRAWINGS

[0012] FIG. 1 is a perspective view of an optical format according to one embodiment of the present invention;

[0013] FIG. 2 is an exploded perspective view of an optical format according to one embodiment of the present invention;

[0014] FIG. 3 is a top cross-sectional view along the line 3-3 of the optical format of FIG. 1; and

[0015] FIG. 4 is a side cross-sectional view along the line 4-4 of the optical format of FIG. 1.

[0016] While the invention is susceptible to various modifications and alternative forms, specific embodiments are shown by way of example in the drawings and will be described in detail herein. However, it should be understood that the invention is not intended to be limited to the particular forms disclosed. Rather, the invention is to cover all modifications, equivalents, and alternatives falling within the spirit and scope of the invention as defined by the appended claims.

DETAILED DESCRIPTION OF THE ILLUSTRATED EMBODIMENTS

[0017] FIG. 1 shows an optical format **10** according to one embodiment of the present invention. The optical format **10** may be used in the collection and optical testing of samples, for example in medical testing applications such as glucose testing or testing of other analytes in biological fluid analysis. The optical format **10** may be created using a variety of fabrication techniques, such as micro-molding, coining, or UV replication processes, and may be constructed of such materials as polycarbonate, polystyrene, and polyester. Formats according to the present invention may be individually cut out of sheet material, cut into one- or two-dimensional arrays, or cut into a circular disc arrangement. Continuous web processing may be used to manufacture formats and format members according to the present invention, resulting in lower processing costs.

[0018] The optical format **10** comprises a first format member **12** and a second format member **14**. Though the first and second format members **12** and **14** are discussed in relation to top and bottom directions as shown in FIG. 1, it is to be understood that these labels are for the purposes of discussion and that the features of optical formats according to the present invention may be alternatively oriented in space—for example, features discussed in combination with the first format member **12** may be placed on a lower format portion according to some embodiments of the present invention.

[0019] The second format member **14** shown in FIG. 1 is provided with a sample fill nose **16**. The sample fill nose **16** provides for the collection of sample fluid from a sample

collection opening **18** and transport of the sample fluid from the sample collection opening **18** to a well **20**. The well **20** is connected to a vent **22** provided with a vent opening **24**. In the embodiment shown in FIG. 1, the sample collection opening **18** is provided on a front face **26** of the optical format, and the vent opening **24** is provided on a back face **28** of the optical format. According to some embodiments of the present invention, sample collection openings and vent openings may be provided on other faces of optical formats, or at face interfaces of optical formats, as required by particular applications of the optical format.

[0020] According to some embodiments of the present invention, the sample fill nose **16** transports sample fluid from the sample collection opening **18** to the well **20** via capillary action. The sample fill nose **16** is preferably provided with dimensions such that the open volume of the sample fill nose **16** is approximately equal to the volume of sample fluid required for analysis within the well **20**.

[0021] In an embodiment in which the sample fill nose **16** has a rectangular cross-section, the sample fill nose **16** has a height, h_n , a width, w_n , and a length, l_n . According to one embodiment of the present invention, the volume of sample preferred for testing within the well **20** is approximately 50 nl. In this embodiment, a sample fill nose **16** having a height h_n of approximately 100 μm , a width w_n of approximately 200 μm and a length, l_n , of approximately 2.4 mm is appropriate to fill the well **20** with the desired amount of sample fluid. Thus, the sample volume is appropriately metered by the sample fill nose **16** during sample collection. According to some embodiments of the present invention, it may be desirable to conduct testing with greater or lesser amounts of fluid, and the well **20** and the sample fill nose **16** may be sized to enable optimum fluid transport to the well **20**. The dimensions of the format are dependent on the manufacturing process, but in general the maximum preferred sample volume of 1 μl limits the size of the format.

[0022] According to some embodiments of the present invention, a platform **28** is provided on an optical format member. The platform **28** is raised from an inner surface **30** of one of the optical platform members, as shown in FIG. 2. FIGS. 1 and 2 show the platform **28** extending downwardly from the inner surface **30** of the first platform member **12**, but it is to be understood that optical formats according to the present invention may employ platforms extending upwardly from a bottom platform member. In the embodiment shown in FIGS. 1 and 2, the platform **28** extends downwardly from the inner surface **30** of the first optical format member **12** and into the well **20** provided in the inner surface **32** of the second optical format member **14**.

[0023] The platform **28** extends a height h_p from the inner surface **30** of the first format member **12**. The platform **28** may be a circular platform with a diameter d_p . According to one embodiment of the present invention, the height h_p of the platform **28** is approximately 50 μm and the diameter d_p of the platform **28** is approximately 1000 μm , but greater or lesser heights and diameters may be used in specific applications of the present invention. For example, heights ranging from about 25 μm to about 250 μm and diameters ranging from about 500 μm to about 2000 μm are preferred in some embodiments of the present invention.

[0024] For the platform **28** to enter the well **20**, the well **20** is provided with a diameter, d_w larger than the diameter d_p

of the platform **28**. According to one embodiment of the present invention, the diameter d_w of the well is approximately 1050 μm . Larger or smaller well diameters are possible. For example, well diameters ranging from about 550 μm to about 2050 μm are preferred in some embodiments of the present invention. Further, the well is provided with a depth h_w that is deeper than the height h_p of the platform **28**, thereby forming a sample testing region **34**, most easily seen in FIG. 4. According to one embodiment of the present invention, the sample testing region **34** has a height h_t of approximately 50 μm . Larger or smaller testing region heights are possible. For example, testing region heights ranging from about 25 μm to about 100 μm are preferred in some embodiments of the present invention.

[0025] The vent **22** extends from the sample testing region **34** toward the rear face **36** of the optical format **10**. According to some embodiments of the present invention, the vent **22** serves to ensure capillary movement of sample from the sample collection opening **18** toward the sample testing region **34**. The vent **22** of the embodiment shown in FIGS. 1-4 has a rectangular cross-section with a height h_v , a width w_v and a length l_v . According to one embodiment of the present invention, the height h_v of the vent is approximately 100 μm , the width w_v of the vent is approximately 500 μm , and the length l_v of the vent is approximately 400 μm . Other vent dimensions are contemplated in other embodiments of the present invention. For example, vent heights ranging from about 50 μm to about 200 μm , vent widths ranging from about 50 μm to about 200 μm , and vent lengths ranging from about 50 μm to about 500 μm are preferred in some embodiments of the present invention. In addition to increasing capillary force in the capillary gap of the sample testing region **34**, the vent **22** may provide an area for sample overflow.

[0026] The platform **28** may be provided with a reagent thereon designed to react with the sample in the sample testing region **34**. Reagent may be placed on the platform via pump depositing, or by methods such as printing, pin deposition, or ink jetting. A reagent may be retained on the platform **28** by oven-drying before assembly of the optical format **10**. According to one embodiment of the present invention, a reagent is deposited on the platform **28** before the optical format members are joined together. In this embodiment of the invention, the platform **28** keeps the reagent from spreading beyond the platform **28** or the sample testing region **34**. Further, when a reagent is uniformly deposited on the platform **28**, a uniform thickness of reagent and a uniform reaction area are achieved. According to some embodiments of the present invention, reagent combines with a sample within the sample testing region **34** to result in a colorimetric reaction. The resulting color may be analyzed using diffuse reflectance or transmission through the sample.

[0027] According to some embodiments of the present invention, adhesive is provided between the format members to glue the first format member **12** to the second format member **14**. In one embodiment of the present invention, heat-activated optically-clear adhesive is coated onto the inner surface of one or both of the format members for adhesion of the format members.

[0028] According to some embodiments of the present invention, top and bottom optical format members both

comprise optically clear material. These embodiments may be used for optical transmission or diffuse reflectance analysis. Alternatively, one of the optical format members may comprise optically reflective material. Embodiments using optically reflecting material may be used in optical analysis based on diffused or reflected light from a sample.

[0029] The formats and methods of the present invention allow for the efficient construction of small and reliable optical formats. As shown in FIG. 1, a format has a format length l_f , a format width w_f , and a format height h_f . According to one embodiment of the present invention, the format length is approximately 3.85 mm, the format width is approximately 3 mm, and the format height is approximately 1 mm. Formats having other dimensions may be preferred in some embodiments of the present invention. For example, format lengths ranging from about 3.00 mm to about 12.5 mm, format widths ranging from about 2.00 mm to about 5.00 mm, and format heights ranging from about 0.50 mm to about 3.00 mm are preferred in some embodiments of the present invention. Optical formats according to the present invention may be designed for handling a wide range of sample fluid volumes. For example, sample volumes from about 5 nl to about 1000 nl are contemplated in some embodiments of the present invention. While the present invention has been described with reference to one or more particular embodiments, those skilled in the art will recognize that many changes may be made thereto without departing from the spirit and scope of the present invention.

[0030] For example, while the present invention has been generally described as directed to medical applications it is to be understood that other optical fluid testing applications might employ the principles of the invention. Each of these embodiments and obvious variations thereof is contemplated as falling within the spirit and scope of the claimed invention, which is set forth in the following claims.

1. A format for optical testing of a sample comprising:
 - a first format member comprising a first inner surface and a platform extending a distance from said inner surface; and
 - a second format member comprising a second inner surface and a well disposed within said second inner surface, said well being shaped to accept said platform of said first format member within said well.
2. The format of claim 1 further comprising a sample fill nose disposed within said second format member and extending along said second inner surface from a sample collection opening at a first end of said sample fill nose to intersect with said well at a second end of said sample fill nose.
3. The format of claim 2 further comprising a vent disposed within said second format member and extending along said second inner surface from a vent opening at a first end of said vent to intersect with said well at a second end of said vent.
4. The format of claim 3 wherein said vent intersects with said well at an area approximately opposing an intersection of said sample fill nose with said well.
5. The format of claim 1 wherein said platform extends from said first inner surface to a platform height and wherein said well extends within said second format member to a well depth greater than said platform height, thereby forming a sample testing region for accepting said sample.

6. The format of claim 1 wherein said platform is provided with a reagent thereon for reacting with said sample.

7. The format of claim 5 wherein said sample testing region has a sample testing region volume and further comprising a fill nose disposed within said second format member and extending from a sample collection opening at a first end to said sample testing region at a second end, said fill nose having a fill nose volume greater than said sample testing region volume, thereby ensuring that sufficient sample volume is available to fill the sample testing region.

8. A format for optical testing of a sample comprising:

- a first format member comprising a first inner surface and a platform extending to a platform height from said inner surface; and
- a second format member comprising a second inner surface and a well disposed within said second inner surface and extending a well depth below said second inner surface, said well being shaped to accept said platform of said first format member within said well thereby forming a sample testing region;
- a sample fill nose extending from a sample collection opening at a first end of said sample fill nose to said well at a second end of said sample fill nose; and
- a vent extending from a vent opening at a first end of said vent to said well at a second end of said vent.

9. The format of claim 8 wherein said platform is cylindrical and has a platform diameter and said well is cylindrical and has a well diameter greater than said platform diameter.

10. The format of claim 8 wherein said sample fill nose is adapted to transport a volume of said sample from said sample collection opening to said sample testing region via capillary action.

11. The format of claim 9 wherein said volume of said sample is approximately 50 nl.

12. The format of claim 9 wherein said volume of said sample is within the range of from approximately 5 nl to approximately 1000 nl.

13. The format of claim 9 wherein said vent opening is provided on an opposite side of said format from said sample collection opening.

14. The format of claim 9 wherein said sample fill nose has a sample fill nose width and said vent has a vent width greater than said sample fill nose width.

15. A method of manufacturing a format for optical testing, the method comprising the acts of:

providing a first format member comprising a first inner surface and a platform extending to a platform height above said first inner surface;

providing a second format member comprising:

- a) a second inner surface and a well disposed within said second inner surface and extending to a well depth below said second inner surface, said well depth being greater than said platform height;
- b) a sample fill nose notch terminating at said well; and
- c) a vent notch terminating at said well; and

joining said first format member to said second format member by inserting said platform of said first format member into said well of said second format member, thereby forming a sample testing region.

16. The method of claim 15 further comprising applying a testing reagent to said platform.

17. The method of claim 15 wherein said sample fill nose notch approximately opposes said vent notch across said well.

18. The method of claim 15 further comprising providing adhesive on one or both of said first and second format members.

19. The method of claim 15 wherein said vent notch has a rectangular cross-section.

20. The method of claim 15 wherein said fill nose notch has a rectangular cross-section.

* * * * *