



(19) **United States**

(12) **Patent Application Publication**  
**SHEU et al.**

(10) **Pub. No.: US 2014/0299913 A1**

(43) **Pub. Date: Oct. 9, 2014**

(54) **INTEGRATED CIRCUITS USING GUARD RINGS FOR ESD SYSTEMS, AND METHODS FOR FORMING THE INTEGRATED CIRCUITS**

(60) Provisional application No. 61/178,613, filed on May 15, 2009.

**Publication Classification**

(71) Applicant: **TAIWAN SEMICONDUCTOR MANUFACTURING COMPANY, LTD.**, Hsinchu (TW)

(51) **Int. Cl.**  
**H01L 27/02** (2006.01)  
**H01L 29/66** (2006.01)  
**H01L 29/06** (2006.01)  
**H01L 29/78** (2006.01)

(72) Inventors: **Ming-Song SHEU**, Hsinchu City (TW);  
**Jian-Hsing LEE**, Hsinchu (TW);  
**Yu-Chang JONG**, Hsinchu City (TW);  
**Chun-Chien TSAI**, Yongkang City (TW)

(52) **U.S. Cl.**  
CPC ..... **H01L 27/0251** (2013.01); **H01L 29/7817** (2013.01); **H01L 29/66681** (2013.01); **H01L 29/0619** (2013.01)  
USPC ..... **257/133**; 438/135

(21) Appl. No.: **14/312,851**

(57) **ABSTRACT**

(22) Filed: **Jun. 24, 2014**

An integrated circuit includes at least one transistor over a substrate, and a first guard ring disposed around the at least one transistor. The integrated circuit further includes a second guard ring disposed around the first guard ring. The integrated circuit further includes a first doped region disposed adjacent to the first guard ring, the first doped region having a first dopant type. The integrated circuit further includes a second doped region disposed adjacent to the second guard ring, the second doped region having a second dopant type.

**Related U.S. Application Data**

(60) Continuation of application No. 13/699,187, filed on Nov. 20, 2012, which is a division of application No. 12/777,672, filed on May 11, 2010, now Pat. No. 8,344,416.

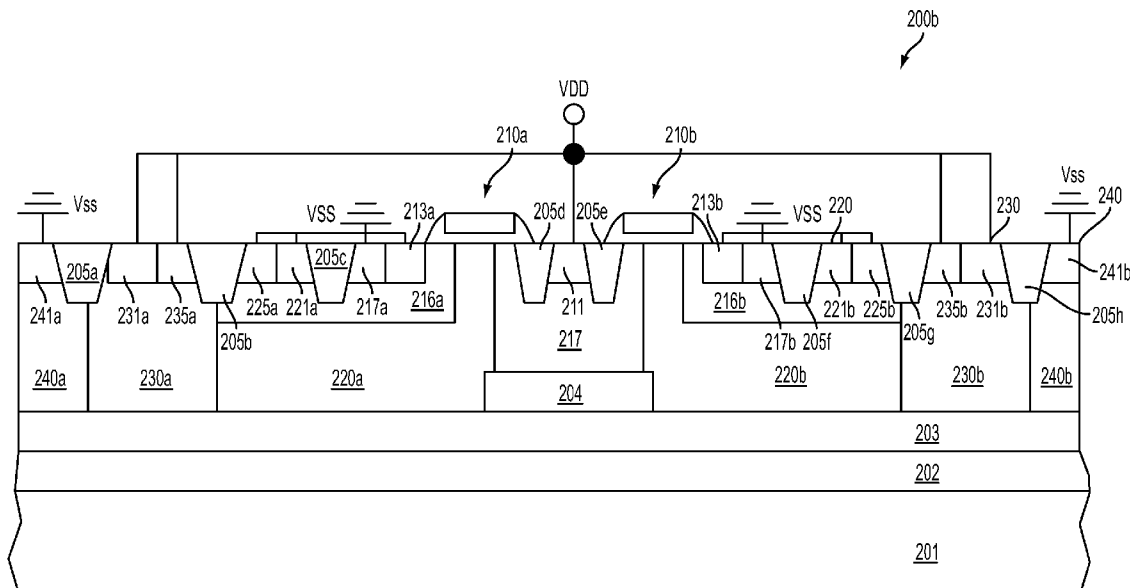

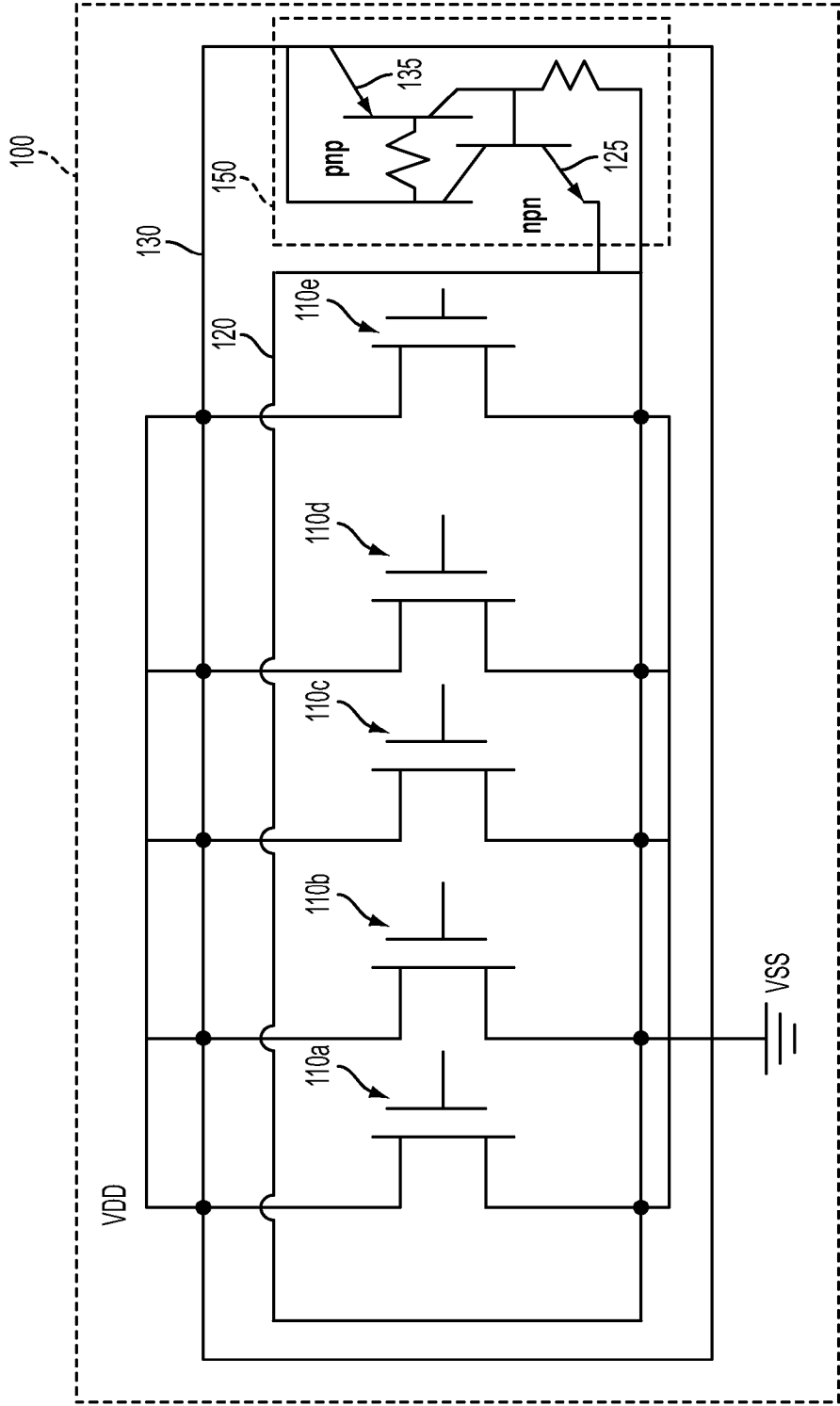
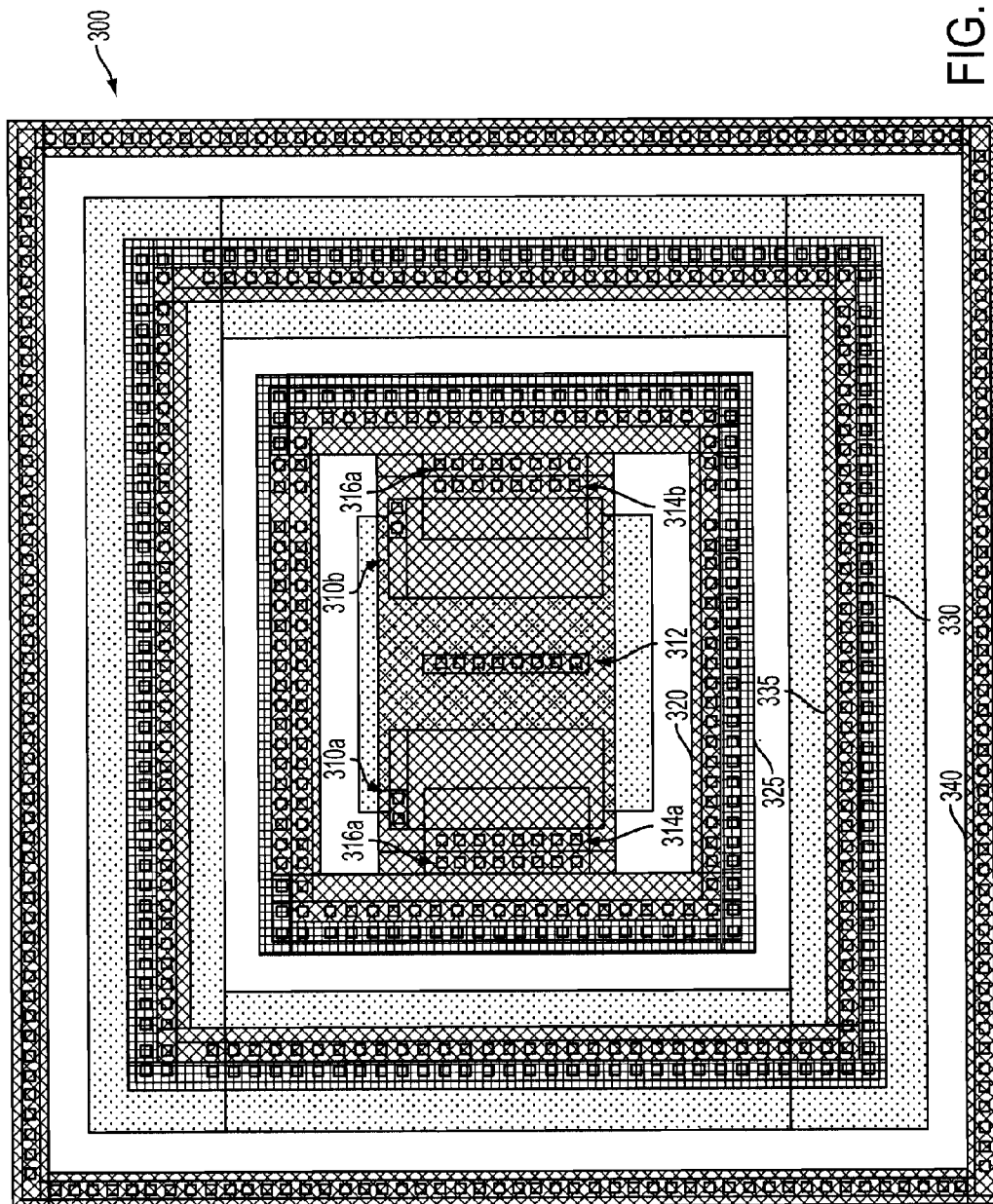

FIG. 1







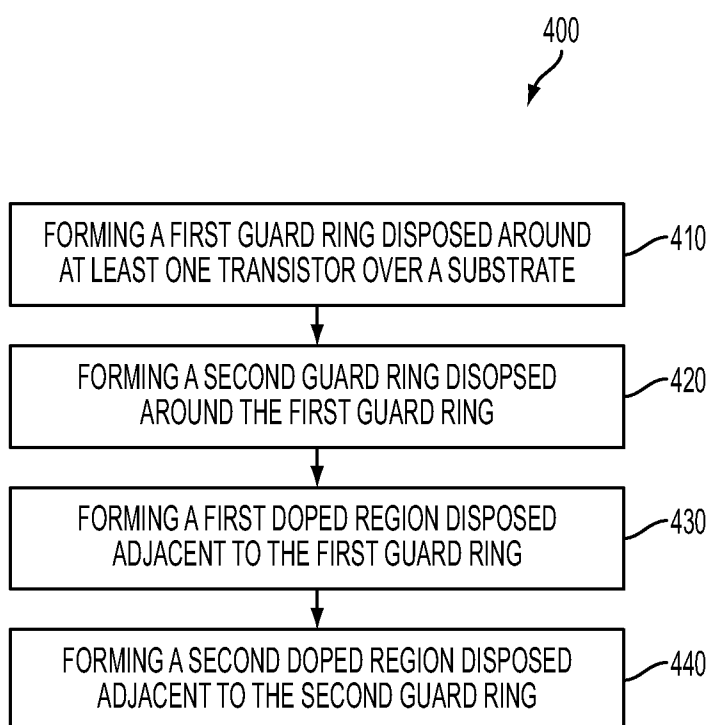

FIG. 4

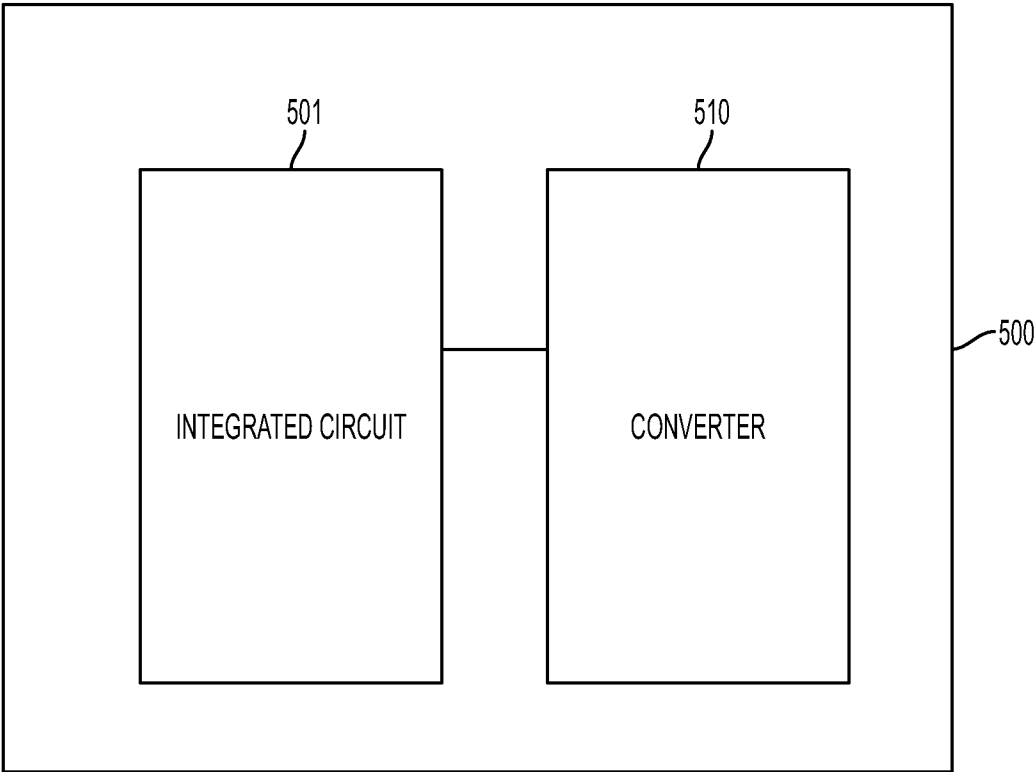

FIG. 5

**INTEGRATED CIRCUITS USING GUARD  
RINGS FOR ESD SYSTEMS, AND METHODS  
FOR FORMING THE INTEGRATED  
CIRCUITS**

PRIORITY CLAIM

[0001] The present application is a continuation of U.S. application Ser. No. 13/699,187, filed Nov. 29, 2012, which is a divisional of U.S. application Ser. No. 12/777,672, filed May 11, 2010, which claims the priority of U.S. Provisional Application No. 61/178,613 filed on May 15, 2009, all of which are incorporated herein by reference in their entireties.

TECHNICAL FIELD

[0002] The present disclosure relates generally to the field of semiconductor circuits, and more particularly, to integrated circuits using guard rings for electrostatic discharge (ESD) systems, and methods for forming the integrated circuits.

BACKGROUND

[0003] The semiconductor integrated circuit (IC) industry has experienced rapid growth. Technological advances in IC materials and design have produced generations of ICs where each generation has smaller and more complex circuits than the previous generation. The scaling of IC techniques to nanometer regime has increased power dissipation. The increased power dissipation causes several problems including reducing battery life in mobile systems, expensive packaging and cooling solutions and can also result in chip failures. Of the various components contributing to power dissipation, leakage or static power dissipation is growing very fast and is predicted to exceed dynamic power dissipation in the near future.

[0004] In another aspect, various devices have been proposed for providing special functions. For example, diffused metal-gate-oxide semiconductor (DMOS) transistors have been proposed for high voltage operations. To integrate the DMOS transistors with conventional bipolar-CMOS transistors, a process named bipolar-CMOS-DMOS (BCD) process has been developed.

BRIEF DESCRIPTION OF THE DRAWINGS

[0005] The present disclosure is best understood from the following detailed description when read with the accompanying figures. It is emphasized that, in accordance with the standard practice in the industry, various features are not drawn to scale and are used for illustration purposes only. In fact, the numbers and dimensions of the various features may be arbitrarily increased or reduced for clarity of discussion.

[0006] FIG. 1 is a schematic drawing showing an exemplary integrated circuit including guard rings disposed around transistors.

[0007] FIG. 2A is a schematic cross-sectional view of an exemplary integrated circuit including guard rings and transistors.

[0008] FIG. 2B is a schematic cross-sectional view of another exemplary integrated circuit including guard rings and transistors.

[0009] FIG. 3 is a schematic drawing illustrating a layout of an exemplary integrated circuit including guard rings disposed around transistors.

[0010] FIG. 4 is a flowchart illustrating a method for forming an exemplary integrated circuit including guard rings around transistors.

[0011] FIG. 5 is a schematic drawing showing a system including an exemplary integrated circuit coupled with a converter.

DETAILED DESCRIPTION

[0012] The conventional DMOS transistor includes a laterally diffused drain that can desirably prevent oxide damage due to a high voltage drop applied between the drain and gate of the conventional DMOS transistor. It is found that if an electrostatic discharge (ESD) occurs at the drain of the conventional DMOS transistor, the conventional DMOS transistor itself cannot survive and release the ESD. The conventional DMOS transistor may be damaged.

[0013] To avoid the ESD situation, a p+ doped region has been proposed to be formed within the drain of the conventional DMOS transistor. The p+ doped region, n-type well, p-type well, and the source of the conventional DMOS transistor can constitute a silicon controlled rectifier (SCR). The SCR can release the ESD occurring at the drain of the DMOS transistor to the ground.

[0014] Based on the foregoing, integrated circuits that are capable of substantially releasing an ESD, systems, and methods for forming the integrated circuits are desired.

[0015] It is understood that the following disclosure provides many different embodiments, or examples, for implementing different features of the disclosure. Specific examples of components and arrangements are described below to simplify the present disclosure. These are, of course, merely examples and are not intended to be limiting. In addition, the present disclosure may repeat reference numerals and/or letters in the various examples. This repetition is for the purpose of simplicity and clarity and does not in itself dictate a relationship between the various embodiments and/or configurations discussed. Moreover, the formation of a feature on, connected to, and/or coupled to another feature in the present disclosure that follows may include embodiments in which the features are formed in direct contact, and may also include embodiments in which additional features may be formed interposing the features, such that the features may not be in direct contact. In addition, spatially relative terms, for example, “lower,” “upper,” “horizontal,” “vertical,” “above,” “below,” “up,” “down,” “top,” “bottom,” etc. as well as derivatives thereof (e.g., “horizontally,” “downwardly,” “upwardly,” etc.) are used for ease of the present disclosure of one features relationship to another feature. The spatially relative terms are intended to cover different orientations of the device including the features.

[0016] FIG. 1 is a schematic drawing showing an exemplary integrated circuit including guard rings disposed around transistors. In FIG. 1, an integrated circuit 100 can include at least one transistor, e.g., transistors 110a-110e. The integrated circuit 100 can include a power switching circuit, a liquid crystal display (LCD) driver, and/or other integrated circuit that is capable of functioning at a high operating voltage.

[0017] Drains of the transistors 110a-110e can be coupled with a voltage source, e.g., VDD, and sources of the transistors 110a-110e can be coupled with another voltage source, e.g., VSS or ground. The transistors 110a-110e can be diffused metal-gate-oxide (DMOS) transistors or transistors that are capable of being operable at an operating voltage of about



26 V or more. In various embodiments, the operating voltage can be around 40 V, 60 V, or more.

[0018] The integrated circuit **100** can include a first guard ring, e.g., guard ring **120**, and a second guard ring, e.g., guard ring **130**. The guard ring **120** can be disposed around the transistors **110a-110e**. The guard ring **130** can be disposed around the guard ring **120**. A first doped region, e.g., a doped region **125**, can be disposed adjacent to the guard ring **120**. A second doped region, e.g., doped region **135**, can be disposed adjacent to the guard ring **130**.

[0019] The guard ring **120** can have a first type dopant, e.g., p-type dopant. The guard ring **130** can have a second type dopant, e.g., n-type dopant. The doped region **125** can have the second type dopant, e.g., n-type dopant. The doped region **135** can have the first type dopant, e.g., p-type dopant. The guard ring **120** can be coupled with the sources of the transistors **110a-110e**. The guard ring **130** can be coupled with the drains of the transistors **110a-110e**. The guard rings **120** and **130** can be configured to substantially electrically insulate the transistors **110a-110e** from other transistors, devices, diodes, and/or circuits outside the guard rings **120** and **130**.

[0020] The guard rings **120**, **130** and the doped regions **125**, **135** can be operable as a silicon controlled rectifier (SCR) **150** to substantially release an electrostatic discharge (ESD). For example, if an ESD occurs at the drains of the transistors **110a-110e**, the ESD can be substantially released through the SCR **150** to the power source VSS. As noted, the transistors **110a-110e** can be operable at the high operating voltage, e.g., 40 V, 60 V, or more. In various embodiments, the SCR **150** of the integrated circuit **100** can meet a human body model (HBM) of an automobile specification. The HBM can be around 8 KV or more.

[0021] FIG. 2A is a schematic cross-sectional view of an exemplary integrated circuit including guard rings and transistors. In FIG. 2A, an integrated circuit **200a** can be similar to the integrated circuit **100**. The integrated circuit **200a** can include transistors **210a** and **210b**, each of which is similar to one of the transistors **110a-110e** shown in FIG. 1.

[0022] In FIG. 2A, the transistors **210a** and **210b** can be formed over a substrate **201**. In various embodiments, the substrate **201** can include an elementary semiconductor including silicon or germanium in crystal, polycrystalline, or an amorphous structure; a compound semiconductor including silicon carbide, gallium arsenic, gallium phosphide, indium phosphide, indium arsenide, and indium antimonide; an alloy semiconductor including SiGe, GaAsP, AlInAs, AlGaAs, GaInAs, GaInP, and GaInAsP; any other suitable material; or combinations thereof. In one embodiment, the alloy semiconductor substrate may have a gradient SiGe feature in which the Si and Ge composition changes from one ratio at one location to another ratio at another location of the gradient SiGe feature. In another embodiment, the alloy SiGe is formed over a silicon substrate. In another embodiment, a SiGe substrate is strained. Furthermore, the semiconductor substrate may be a semiconductor on insulator, such as a silicon on insulator (SOI), or a thin film transistor (TFT). In some examples, the semiconductor substrate may include a doped epi layer or a buried layer. In other examples, the compound semiconductor substrate may have a multilayer structure, or the substrate may include a multilayer compound semiconductor structure.

[0023] In various embodiments, an epi-layer **202**, e.g., a p-type epi-layer, can be formed over the substrate **201**. An n-type buried layer (NBL) **203** can be formed over the epi-

layer **202**. A deep well **204**, e.g., a deep p-type well (DPW), can be formed over the NBL **203**. A well **217**, e.g., a high-voltage n-type well (HVNW), can be formed over the deep well **204**. Isolation structures **205a-205h**, e.g., field oxide layers or shallow trench isolation (STI) structures, can be disposed between guard rings and between sources and drains of the transistors **210a** and **210b**. In various embodiments, the wells and layers described above are configured for the high-voltage operation of the transistors **210a** and **210b**. One of skill in the art can add more or remove the wells and/or the layers to achieve a desired integrated circuit for the high-voltage operation.

[0024] Referring again to FIG. 2A, drains **211** of the transistors **210a** and **210b** can be coupled with a power source, e.g., VDD. Sources **213a** and **213b** of the transistors **210a** and **210b**, respectively, can be coupled with a power source, e.g., VSS or ground. Doped regions **215a** and **215b**, e.g., p-type doped regions, can be formed around the sources **213a** and **213b**, respectively. The doped regions **215a** and **215b** can be operable to provide channels for the transistors **210a** and **210b**, respectively. In various embodiments, the doped regions **215a** and **215b** can be referred to as p-type body regions. Doped regions **217a** and **217b** can be disposed adjacent to the sources **213a** and **213b**, respectively, and coupled with the power source VSS.

[0025] The integrated circuit **200a** can include a guard ring **220**, e.g., a p-type guard ring, including p-type wells **220a**, **220b** and p+ doped regions **221a**, **221b**. In various embodiments, the p+ doped regions **221a** and **221b** can be referred to as pickup regions for the p-type wells **220a** and **220b**, respectively. A guard ring **230**, e.g., an n-type guard ring, can be disposed around the guard ring **220**. The guard ring **230** can include n-type wells **230a**, **230b** and n+ doped regions **231a**, **231b**. In various embodiments, the n+ doped regions **231a** and **231b** can be referred to as pickup regions for the n-type wells **230a** and **230b**, respectively.

[0026] Referring to FIG. 2A, the integrated circuit **200a** can include doped regions **225a** and **225b**, e.g., n+ doped regions, disposed adjacent to the p+ doped regions **221a** and **221b**, respectively. In various embodiments, the doped regions **225a** and **225b** can be coupled with the power source VSS. Doped regions **235a** and **235b**, e.g., p+ doped regions, can be disposed adjacent to the n+ doped regions **231a** and **231b**, respectively. The doped regions **235a** and **235b** can be coupled with the power source VDD. In various embodiments, the doped regions **225a** and **225b** can be spaced from the drains **211** by the guard ring **220**. In other various embodiments, the doped regions **225a** and **225b** can be spaced from the doped regions **235a** and **235b** by the isolation structure **205b** and **205g**, respectively. The isolation structure **205b** and **205g** can insulate the doped regions **225a** and **225b** from the doped regions **235a** and **235b**.

[0027] It is found that the doped region **225a**, the p-type well **220a**, and the n-type well **230a** can serve as an npn transistor. The doped region **235a**, the n-type well **230a**, and the p-type well **220a** can serve as a pnp transistor. The npn and pnp transistors can be operable as an SCR. If an ESD occurs at the drains **211** of the transistors **210a** and **210b**, the SCR including the npn and pnp transistors can be triggered to substantially release the ESD to the power source VSS.

[0028] In various embodiments, the integrated circuit **200a** can include a guard ring **240**, e.g., a p-type guard ring, including p-type wells **240a**, **240b** and p+ doped regions **241a**, **241b**. In various embodiments, the p+ doped regions **241a**

and **241b** can be referred to as pickup regions for the p-type wells **240a** and **240b**, respectively. The integrated circuit **200a** can include doped regions (not shown), e.g., n+ doped regions, disposed adjacent to the p+ doped regions **241a** and **241b**. In various embodiments, the doped regions (not shown) adjacent to the p+ doped regions **241a** and **241b** can be coupled with the power source VSS. It is found that the doped region (not shown) adjacent to the p+ doped region **241a**, the p-type well **240a**, and the n-type well **230a** can form an npn transistor. The doped region **235a**, the n-type well **230a**, and the p-type well **240a** can form a pnp transistor. The npn and pnp transistors can be operable as another SCR. If an ESD occurs at the drains **211** of the transistors **210a** and **210b**, the SCR including the npn and pnp transistors can be triggered to release the ESD to the power source VSS.

**[0029]** FIG. 2B is a schematic cross-sectional view of another exemplary integrated circuit including guard rings and transistors. Items of FIG. 2B that are the same items in FIG. 2A are indicated by the same reference numerals. In FIG. 2B, an integrated circuit **200b** can include doped regions **216a** and **216b**, e.g., p-type doped regions. The doped regions **216a** and **216b** can be disposed within the p-type wells **220a** and **220b**, respectively. The doped regions **216a** and **216b** can be coupled with the n-type wells **230a** and **230b**, respectively. The doped regions **216a** and **216b** can be disposed around the sources **213a** and **213b**, respectively. The doped regions **216a** and **216b** can be operable to provide channels for the transistors **210a** and **210b**, respectively. In various embodiments, the doped regions **216a** and **216b** can be referred to as p-type body regions.

**[0030]** It is noted that either one of both of the SCR formed between the guard rings **220** and **230** and the SCR formed between the guard rings **230** and **240** can be operable to release the ESD. One of skill in the art can use one, two, or more SCRs to release the ESD. It is also noted that the number of the guard rings described above in conjunction with FIGS. 1, 2A, and 2B is merely exemplary. One of skill in the art can modify the number of the guard rings to achieve a desired number of the SCR. The dopant types of the guard rings, wells, layers, and/or doped regions described above in conjunction with FIGS. 1, 2A, and 2B are merely exemplary. One of skill in the art can modify or change the dopant type to achieve a desired integrated circuit having the SCR for ESD.

**[0031]** FIG. 3 is a schematic drawing illustrating a layout of an exemplary integrated circuit including guard rings disposed around transistors. Items of FIG. 3 that are the same items in FIG. 2A are indicated by the same reference numerals, increased by **100**. In FIG. 3, contacts **312** can be coupled with the drains **211** (shown in FIG. 2A). Contacts **314a** and **314b** can be coupled with the sources **213a** and **213b** (shown in FIG. 2A), respectively. Contacts **316a** and **316b** can be coupled with the doped regions **217a** and **217b** (shown in FIG. 2A), respectively.

**[0032]** Referring to FIG. 3, a doped region **325** can be disposed adjacent to a guard ring **320**. In various embodiments, the doped region **325** can be disposed around the guard ring **320**. A doped region **335** can be disposed adjacent to a guard ring **330**. In various embodiments, the guard ring **330** can be disposed around the doped region **335**. The guard ring **320**, the doped region **325**, and the guard ring **330** can serve as a pnp transistor. The guard ring **330**, the doped region **335**, and the guard ring **320** can serve as an npn transistor. If an

ESD occurs at the drains of the transistors **310a** and **310b**, the pnp and npn transistors can function as a SCR to release the ESD.

**[0033]** It is found that the doped regions **325** and **335** can be disposed adjacent to the guard rings **320** and **330**, respectively. In various embodiments, the guard rings **320** and **330** can be formed and then the doped regions **325** and **335** can be formed within the guard rings **320** and **330**, respectively. By taking portions of the guard rings **320** and **330**, forming the doped regions **325** and **335** is substantially free from increasing the area of the integrated circuit **300**.

**[0034]** FIG. 4 is a flowchart illustrating a method for forming an exemplary integrated circuit including guard rings around transistors. In FIG. 4, a step **410** can form a first guard ring disposed around at least one transistor over a substrate. For example, the step **410** can form the guard ring **220** around the transistors **210a** and **210b** over the substrate **201** (shown in FIG. 2A). As noted, the guard ring **220** can include the p-type wells **220a**, **220b** and p+ doped regions **221a**, **221b**. In various embodiments, the p-type wells **220a**, **220b** and p+ doped regions **221a**, **221b** can be formed by implantation processes. In various embodiments, the transistors **210a** and **210b** can be formed by a process forming DMOS transistors.

**[0035]** Referring to FIG. 4, a step **420** can form a second guard ring around the first guard ring. For example, the step **420** can form the guard ring **230** around the guard ring **220** (shown in FIG. 2A). As noted, the guard ring **230** can include the n-type wells **230a**, **230b** and n+ doped regions **231a**, **231b**. In various embodiments, the n-type wells **230a**, **230b** and n+ doped regions **231a**, **231b** can be formed by implantation processes.

**[0036]** Referring to FIG. 4, a step **430** can form a first doped region disposed adjacent to the first guard ring. For example, the step **430** can form the doped regions **225a** and **225b** adjacent to the guard ring **220**. The doped regions **225a** and **225b** can be formed by an implantation process. In various embodiments, the doped regions **225a**, **225b** and the drains **211** of the transistors **210a**, **210b** can be formed by the same implantation process. The process **400** can be free from adding additional step to form the doped regions **225a** and **225b**. In other embodiments, the doped regions **225a**, **225b** and the drains **211** of the transistors **210a**, **210b** can be formed by different implantation processes.

**[0037]** Referring again to FIG. 4, a step **440** can form a second doped region disposed adjacent to the second guard ring. For example, the step **440** can form the doped regions **235a** and **235b** adjacent to the guard ring **230**. The doped regions **235a** and **235b** can be formed by an implantation process. In various embodiments, the doped regions **235a**, **235b** and the sources **213a** and **213b** of the transistors **210a** and **210b** can be formed by the same implantation process. The process **400** can be free from adding an additional step to form the doped regions **235a** and **235b**. In other embodiments, the doped regions **235a**, **235b** and the sources **213a**, **213b** of the transistors **210a**, **210b** can be formed by different implantation processes.

**[0038]** In various embodiments, the process **400** can include a step (not shown) forming a third guard ring around the second guard ring. For example, the step can form the guard ring **240** around the guard ring **230** (shown in FIG. 2A). As noted, the guard ring **240** can include the p-type wells **240a**, **240b** and p+ doped regions **241a**, **241b**. In various embodiments, the guard rings **220** and **240** can be formed by

the same implantation process. In other embodiments, the guard rings **220** and **240** can be formed by different implantation process steps.

**[0039]** FIG. **5** is a schematic drawing showing a system including an exemplary integrated circuit coupled with a converter. In FIG. **5**, a system **500** can include an integrated circuit **501** coupled with a converter **510**. The converter **510** is capable of receiving an external power voltage, converting the external power voltage to the operating voltage VDD. The operating voltage VDD can be applied to the integrated circuit **501** for operations. In various embodiments, the converter **510** can be a DC-to-DC converter, an AC-to-DC converter, or other voltage converter that can provide a high operating voltage VDD, e.g., about 40 V or more. In various embodiments, the integrated circuit **501** can be similar to one of the integrated circuits **100-300** described above in conjunction with FIGS. **1-3**, respectively.

**[0040]** In various embodiments, the integrated circuit **501** and the converter **510** can be formed within a system that can be physically and electrically coupled with a printed wiring board or printed circuit board (PCB) to form an electronic assembly. The electronic assembly can be part of an electronic system such as computers, wireless communication devices, computer-related peripherals, entertainment devices, or the like.

**[0041]** In various embodiments, the system **500** including the integrated circuit **501** can provide an entire system in one IC, so-called system on a chip (SOC) or system on integrated circuit (SOIC) devices. These SOC devices may provide, for example, all of the circuitry needed to implement a cell phone, personal data assistant (PDA), digital VCR, digital camcorder, digital camera, MP3 player, or the like in a single integrated circuit.

**[0042]** One aspect of this description relates to an integrated circuit. The integrated circuit includes at least one transistor over a substrate, and a first guard ring disposed around the at least one transistor. The integrated circuit further includes a second guard ring disposed around the first guard ring. The integrated circuit further includes a first doped region disposed adjacent to the first guard ring, the first doped region having a first dopant type. The integrated circuit further includes a second doped region disposed adjacent to the second guard ring, the second doped region having a second dopant type.

**[0043]** Another aspect of this description relates to a method for forming an integrated circuit. The method includes forming a first guard ring around at least one transistor over a substrate. The method further includes forming a second guard ring around the first guard ring. The method further includes forming a first doped region adjacent to the first guard ring, the first doped region having a first dopant type. The method further includes forming a second doped region adjacent to the second guard ring, the second doped region having a second dopant type.

**[0044]** Still another aspect of this description relates to an integrated circuit. The integrated circuit includes at least one transistor over a substrate. The integrated circuit further includes a first guard ring disposed around the at least one transistor, the first guard ring comprising a first well region in the substrate, the first well region having a first dopant type. The integrated circuit further includes a second guard ring surrounding the first guard ring, the second guard ring comprising a second well region in the substrate, the second well region having a second dopant type. The integrated circuit

further includes a first doped region in the first well region, the first doped region having the second dopant type, wherein the first doped region, the first well region and the second well region are configured to form a transistor.

**[0045]** The foregoing outlines features of several embodiments so that those skilled in the art may better understand the aspects of the present disclosure. Those skilled in the art should appreciate that they may readily use the present disclosure as a basis for designing or modifying other processes and structures for carrying out the same purposes and/or achieving the same advantages of the embodiments introduced herein. Those skilled in the art should also realize that such equivalent constructions do not depart from the spirit and scope of the present disclosure, and that they may make various changes, substitutions, and alterations herein without departing from the spirit and scope of the present disclosure.

What is claimed is:

1. An integrated circuit comprising:
  - at least one transistor over a substrate;
  - a first guard ring disposed around the at least one transistor;
  - a second guard ring disposed around the first guard ring;
  - a first doped region disposed adjacent to the first guard ring, the first doped region having a first dopant type; and
  - a second doped region disposed adjacent to the second guard ring, the second doped region having a second dopant type.
2. The integrated circuit of claim **1**, wherein the at least one transistor is a plurality of transistors, the plurality of transistors having a shared drain.
3. The integrated circuit of claim **1**, wherein the first guard ring comprises a first well region, wherein the first well region is disposed between a source and a drain of the at least one transistor.
4. The integrated circuit of claim **1**, wherein the at least one transistor comprises a drain and the drain is electrically connected to the second doped region.
5. The integrated circuit of claim **1**, wherein the at least one transistor comprises a source and the source is electrically connected to the first doped region.
6. The integrated circuit of claim **5**, wherein an isolation region is positioned between the source and the first doped region.
7. The integrated circuit of claim **1**, wherein the at least one transistor comprises:
  - a source; and
  - a doped body between the source and the first guard ring.
8. The integrated circuit of claim **7**, wherein the doped body is in contact with the second guard ring.
9. The integrated circuit of claim **1**, wherein the first guard ring has a same dopant type as the second guard ring.
10. A method for forming an integrated circuit, the method comprising:
  - forming a first guard ring around at least one transistor over a substrate;
  - forming a second guard ring around the first guard ring;
  - forming a first doped region adjacent to the first guard ring, the first doped region having a first dopant type; and
  - forming a second doped region adjacent to the second guard ring, the second doped region having a second dopant type.
11. The method of claim **10**, further comprising forming the at least one transistor over the substrate, wherein forming the at least one transistor comprises forming a plurality of transistors having a shared drain.

**12.** The method of claim **10**, further comprising forming the at least one transistor over the substrate, wherein the at least one transistor comprises a drain electrically connected to the second doped region.

**13.** The method of claim **10**, further comprising forming the at least one transistor over the substrate, wherein the at least one transistor comprises a source electrically connected to the first doped region.

**14.** The method of claim **13**, wherein forming the at least one transistor comprises forming a doped body between the source and the first guard ring.

**15.** The method of claim **14**, wherein forming the doped body comprises forming the doped body in contact with the second guard ring.

**16.** An integrated circuit comprising:

at least one transistor over a substrate;

a first guard ring disposed around the at least one transistor, the first guard ring comprising a first well region in the substrate, the first well region having a first dopant type; a second guard ring surrounding the first guard ring, the second guard ring comprising a second well region in the substrate, the second well region having a second dopant type; and

a first doped region in the first well region, the first doped region having the second dopant type, wherein the first doped region, the first well region and the second well region are configured to form a transistor.

**17.** The integrated circuit of claim **16**, further comprising a third guard ring surrounding the second guard ring, the third guard ring comprising a third well region in the substrate, the third well region having the first dopant type.

**18.** The integrated circuit of claim **17**, further comprising a third doped region in the third well region, wherein the third doped region, the third well region and the second well region are configured to form a transistor.

**19.** The integrated circuit of claim **16**, wherein the at least one transistor comprises a source electrically connected to the first doped region.

**20.** The integrated circuit of claim **16**, further comprising a second doped region in the second well region, wherein the at least one transistor comprises a drain electrically connected to the second doped region.

\* \* \* \* \*