



US 20230084061A1

(19) **United States**

(12) **Patent Application Publication**
Byers et al.

(10) **Pub. No.: US 2023/0084061 A1**

(43) **Pub. Date: Mar. 16, 2023**

(54) **METHOD FOR TUNING AN ELECTRICALLY SMALL ANTENNA**

(71) Applicant: **Honeywell Federal Manufacturing & Technologies, LLC**, Kansas City, MO (US)

(72) Inventors: **Kyle J. Byers**, Kansas City, MO (US);
Louis Brown, Kansas City, MO (US);
Daniel John Salzman, Lee's Summit, MO (US)

(73) Assignee: **Honeywell Federal Manufacturing & Technologies, LLC**, Kansas City, MO (US)

(21) Appl. No.: **17/940,800**

(22) Filed: **Sep. 8, 2022**

Related U.S. Application Data

(62) Division of application No. 16/918,157, filed on Jul. 1, 2020, now Pat. No. 11,489,263.

Publication Classification

(51) **Int. Cl.**
H01Q 9/14 (2006.01)
H01Q 1/36 (2006.01)
H01Q 9/30 (2006.01)
(52) **U.S. Cl.**
CPC *H01Q 9/14* (2013.01); *H01Q 1/36* (2013.01); *H01Q 9/30* (2013.01)

(57) **ABSTRACT**

A method of tuning an electrically small antenna comprising a radiating element and a support structure comprises applying a force to the support structure to change a shape or a dimension of the radiating element to increase or decrease a frequency at which the electrically small antenna resonates.

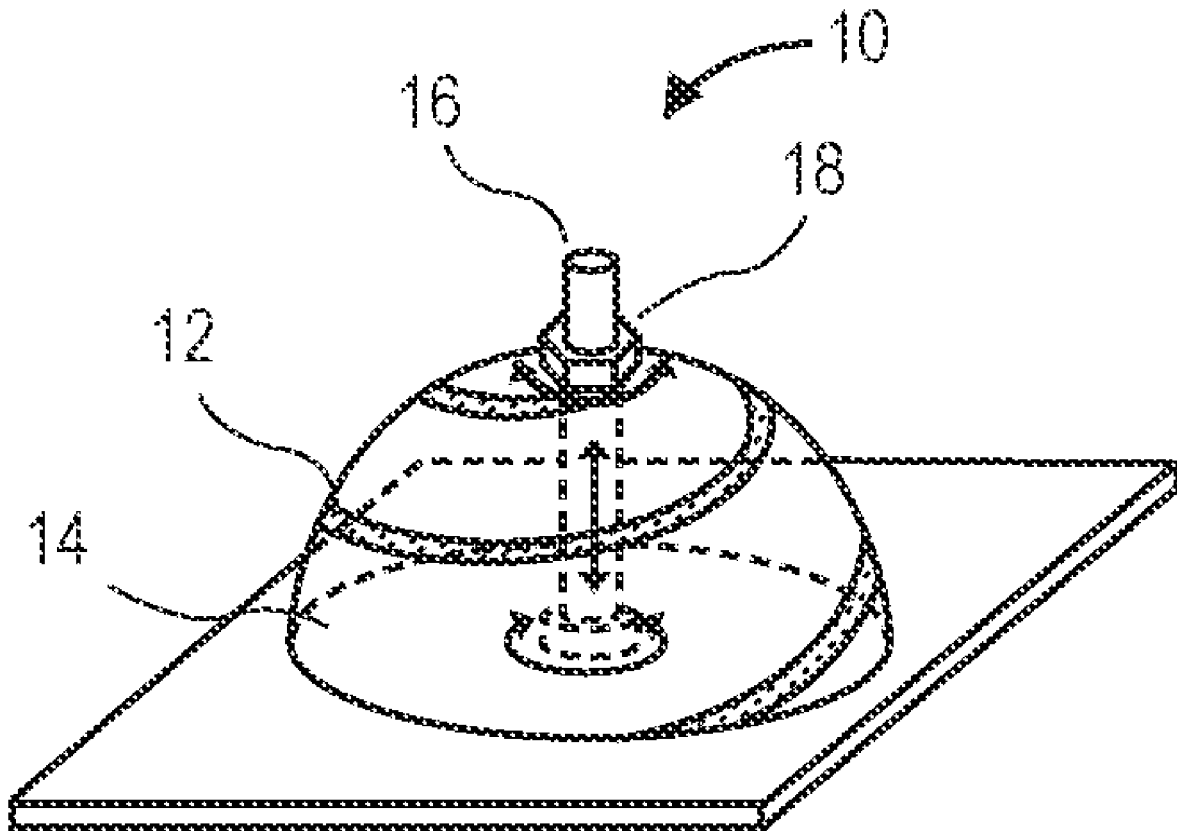

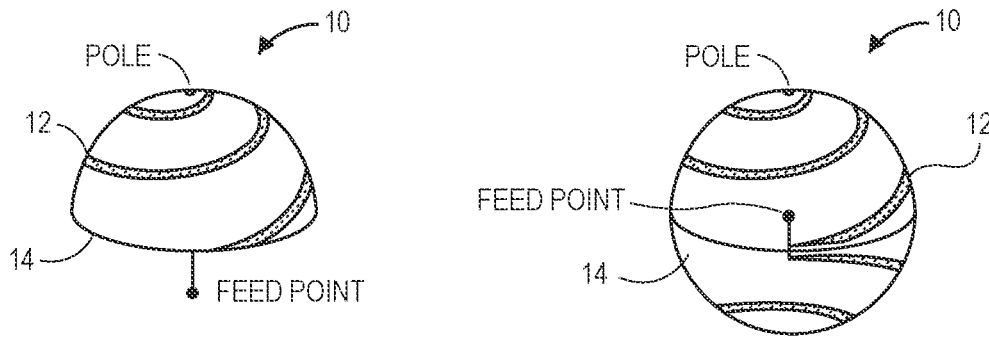

FIG. 1

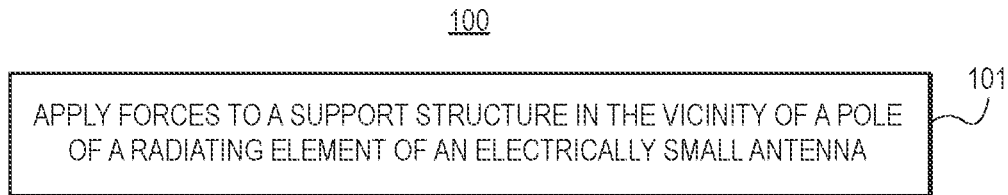

FIG. 2

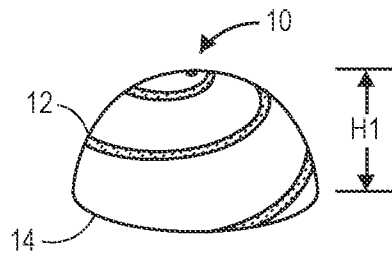

FIG. 3A

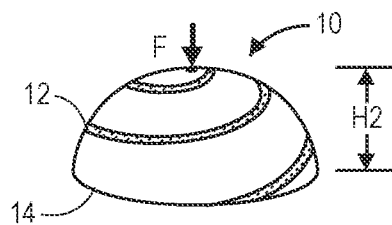

FIG. 3B

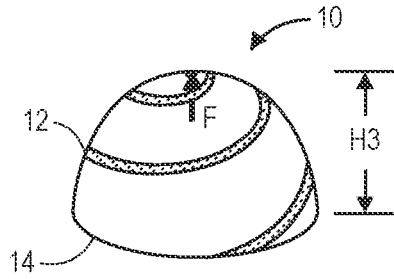

FIG. 3C

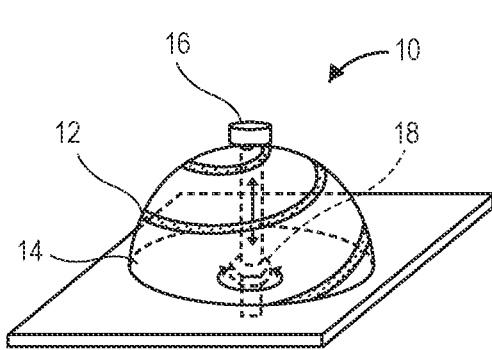

FIG. 4A

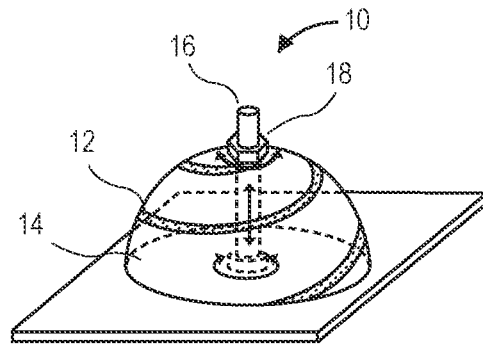

FIG. 4B

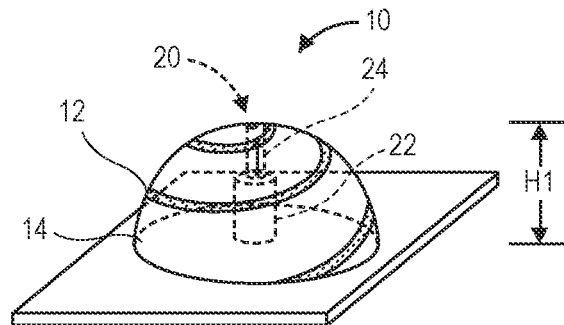

FIG. 5A

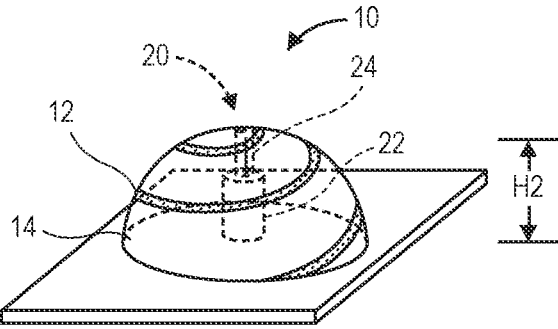

FIG. 5B

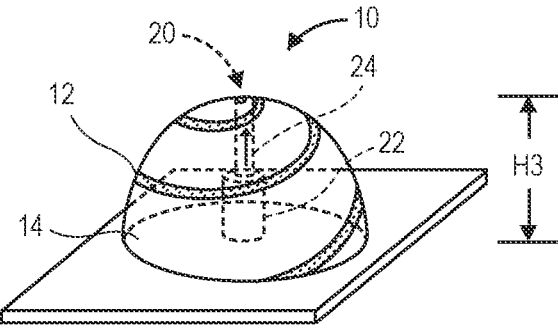

FIG. 5C

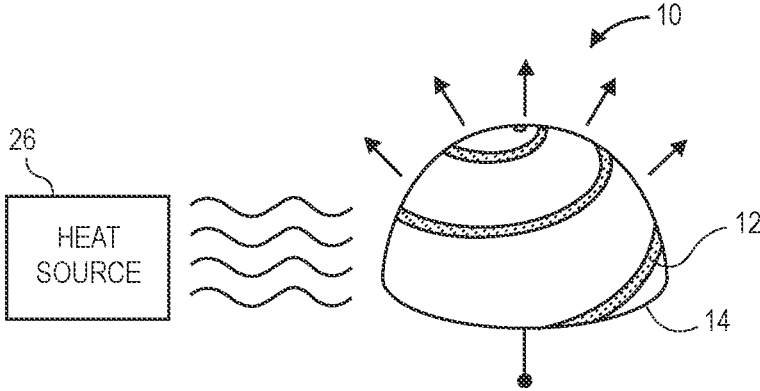

FIG. 6

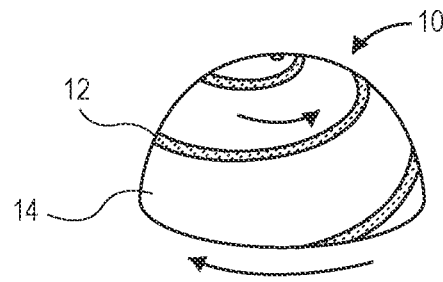

FIG. 7A

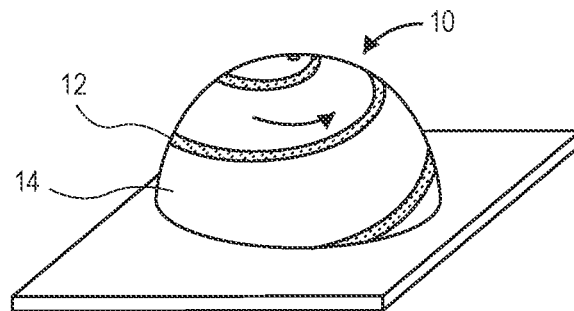

FIG. 7B

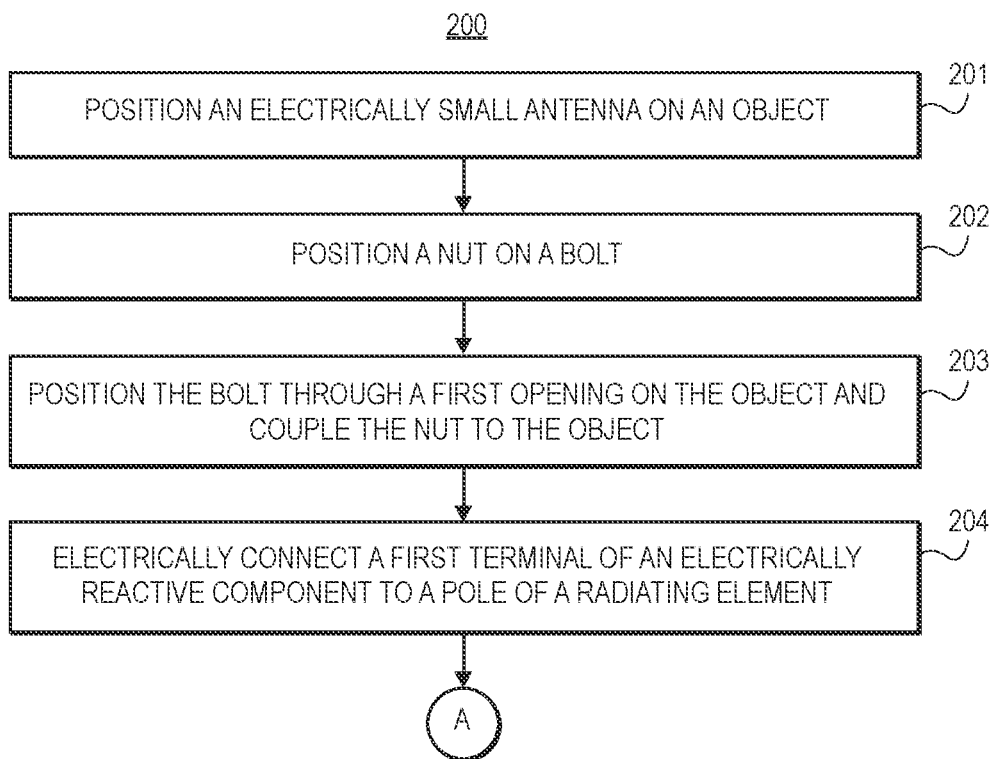

FIG. 8A

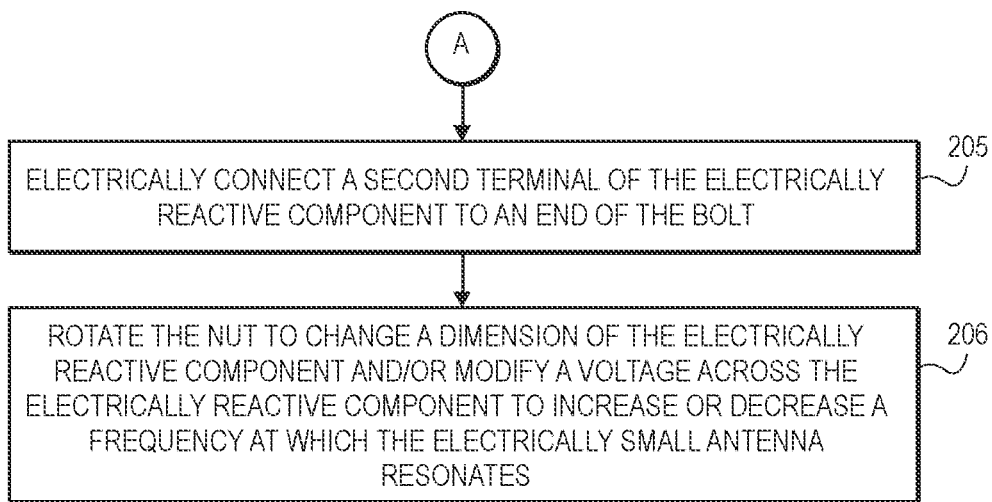

FIG. 8B

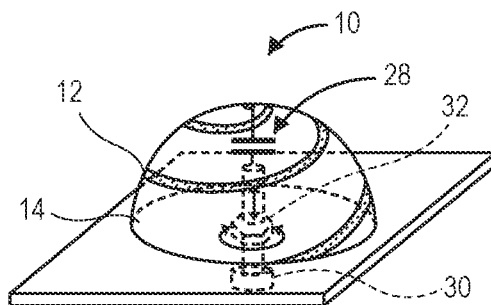

FIG. 9

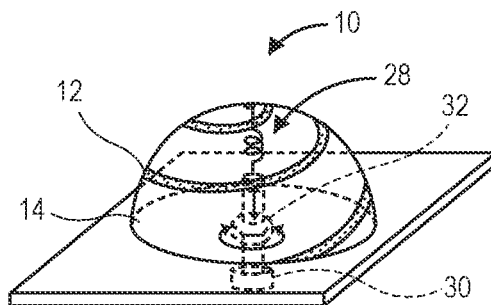

FIG. 10

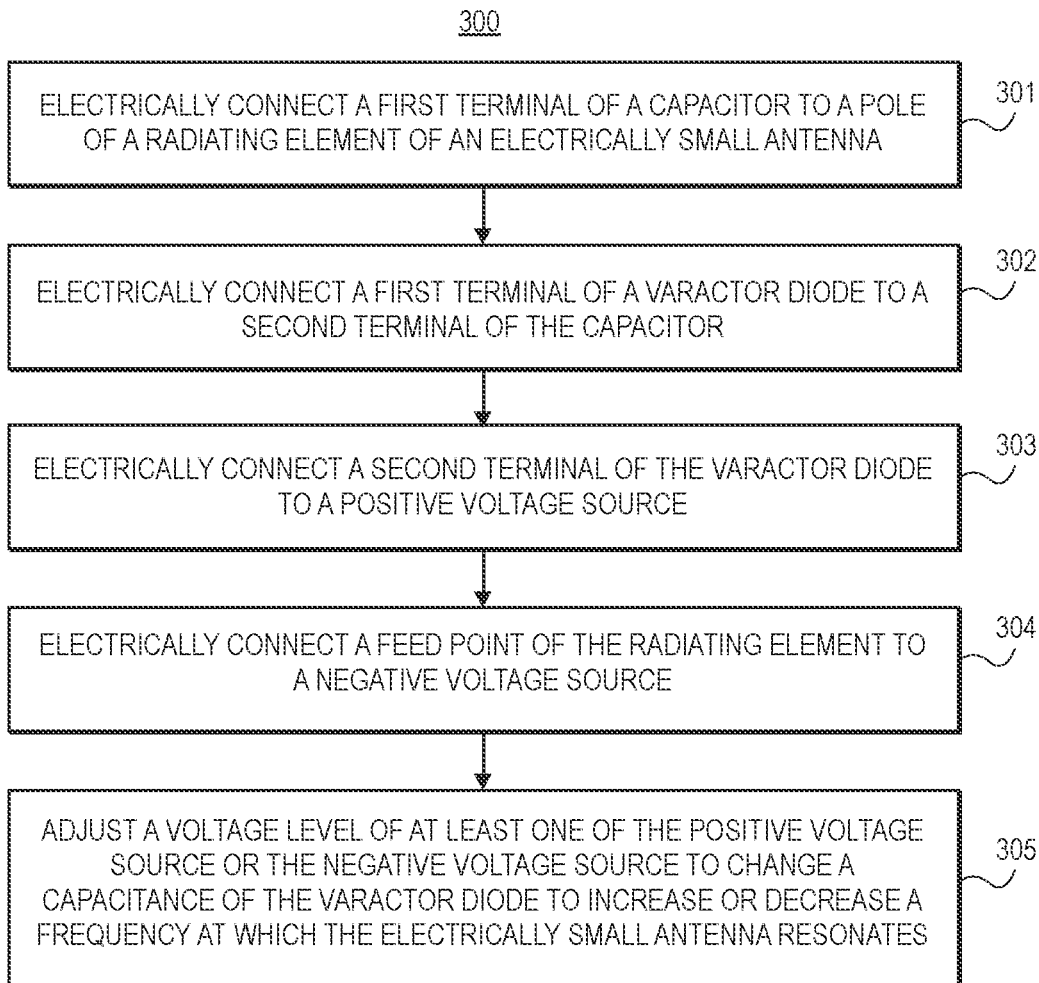

FIG. 11

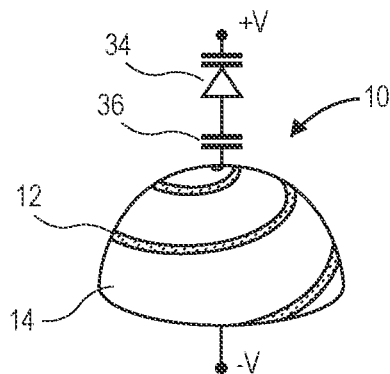

FIG. 12

400

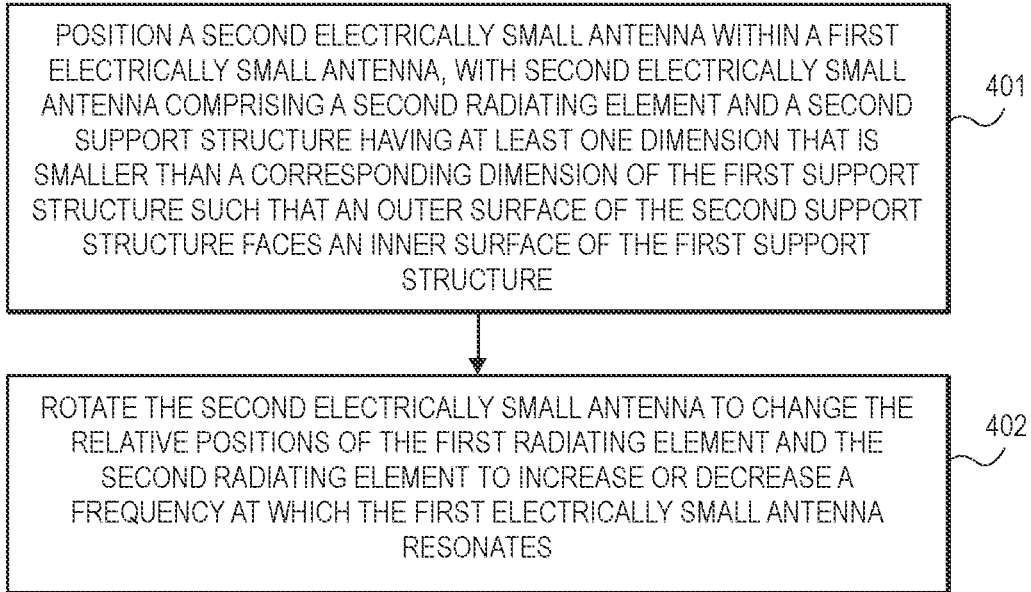

FIG. 13

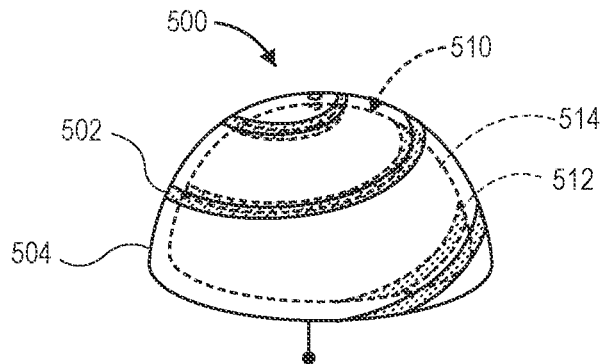

FIG. 14A

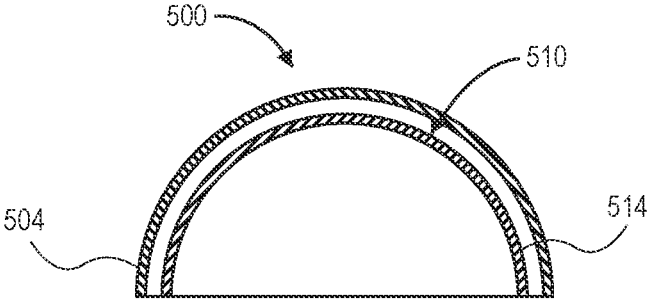

FIG. 14B

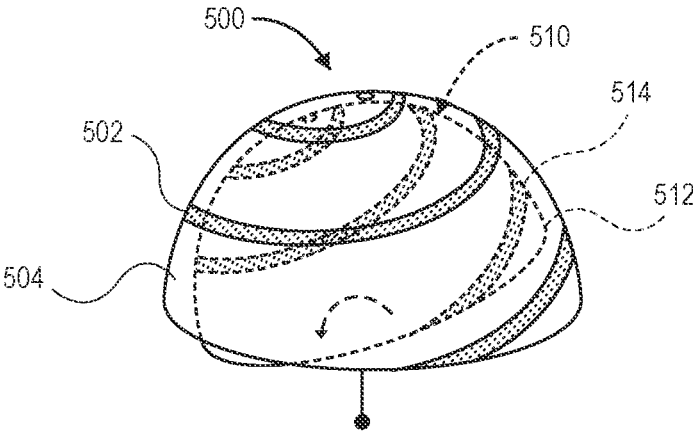

FIG. 14C

METHOD FOR TUNING AN ELECTRICALLY SMALL ANTENNA

RELATED APPLICATION

[0001] The current patent application is a divisional patent application which claims priority benefit, with regard to all common subject matter, of earlier-filed U.S. patent application Ser. No. 16/918,157; titled “METHOD FOR TUNING AN ELECTRICALLY SMALL ANTENNA”, filed Jul. 1, 2020. The earlier-filed patent application is hereby incorporated by reference, in its entirety, into the current patent application.

STATEMENT REGARDING FEDERALLY-SPONSORED RESEARCH OR DEVELOPMENT

[0002] This invention was made with Government support under Contract No.: DE-NA0002839 awarded by the United States Department of Energy/National Nuclear Security Administration. The Government has certain rights in the invention.

FIELD OF THE INVENTION

[0003] Embodiments of the current invention relate to methods for tuning an electrically small antenna.

DESCRIPTION OF THE RELATED ART

[0004] An electrically small antenna is generally classified as an antenna formed on a volume with a spherical diameter that is significantly smaller than a wavelength of a wireless signal the antenna is supposed to transmit and/or receive. Typically, electrically small antennas are configured to fit into small spaces or areas in which tuning of the antenna may be difficult. Furthermore, in some cases, tuning of the electrically small antenna may result in a loss bandwidth of the wireless signal the antenna is to transmit and/or receive.

SUMMARY OF THE INVENTION

[0005] Embodiments of the current invention solve the above-mentioned problems and provide methods of tuning an electrically small antenna that can be easily and automatically implemented and that do not result in the loss bandwidth of a wireless signal the antenna is to transmit and/or receive. The electrically small antenna comprises a radiating element configured to transmit and/or receive the wireless signal and a support structure on which the radiating element is positioned. One method of tuning the electrically small antenna broadly comprises applying forces to the support structure to change a shape or a dimension of the radiating element to increase or decrease a frequency at which the electrically small antenna resonates.

[0006] Another method of tuning an electrically small antenna broadly comprises positioning the electrically small antenna on an upper surface of a planar object; coupling a first component of a mechanism to the support structure; coupling a second component of the mechanism to the planar object; and applying a mechanical action to the first component, the second component, or both to exert a force on the support structure to change a shape or a dimension of the radiating element to increase or decrease a frequency at which the electrically small antenna resonates.

[0007] Another method of tuning an electrically small antenna broadly comprises applying at least a first force to the support structure to an upper portion of the support structure in a first direction to create a torsion on the support structure that changes a shape or a dimension of the radiating element to increase or decrease a frequency at which the electrically small antenna resonates.

[0008] This summary is provided to introduce a selection of concepts in a simplified form that are further described below in the detailed description. This summary is not intended to identify key features or essential features of the claimed subject matter, nor is it intended to be used to limit the scope of the claimed subject matter. Other aspects and advantages of the current invention will be apparent from the following detailed description of the embodiments and the accompanying drawing figures.

BRIEF DESCRIPTION OF THE DRAWING FIGURES

[0009] Embodiments of the current invention are described in detail below with reference to the attached drawing figures, wherein:

[0010] FIG. 1 is a perspective view of first and second embodiments of an electrically small antenna;

[0011] FIG. 2 illustrates a listing of a step of a first method of tuning an electrically small antenna;

[0012] FIG. 3A is a perspective view of the electrically small antenna illustrating a first height of the antenna;

[0013] FIG. 3B is a perspective view of the electrically small antenna illustrating a downward force applied which results in a second height of the antenna;

[0014] FIG. 3C is a perspective view of the electrically small antenna illustrating an upward force applied which results in a third height of the antenna;

[0015] FIG. 4A is a perspective view of the electrically small antenna illustrating some embodiments of a manual implementation of the first method of tuning the electrically small antenna;

[0016] FIG. 4B is a perspective view of the electrically small antenna illustrating other embodiments of the manual implementation of the first method of tuning the electrically small antenna;

[0017] FIG. 5A is a perspective view of the electrically small antenna including an actuator exerting no force which results in a first height of the antenna;

[0018] FIG. 5B is a perspective view of the electrically small antenna including the actuator exerting a downward force which results in a second height of the antenna;

[0019] FIG. 5C is a perspective view of the electrically small antenna including the actuator exerting an upward force which results in a third height of the antenna;

[0020] FIG. 6 is a perspective view of the electrically small antenna with a heat source that generates heat toward the antenna;

[0021] FIG. 7A is a perspective view of the electrically small antenna with first and second opposing forces exerting a torsion on the antenna;

[0022] FIG. 7B is a perspective view of the electrically small antenna attached to a planar surface and including a first force exerting a torsion on the antenna;

[0023] FIGS. 8A and 8B illustrate a listing of the steps of a second method of tuning an electrically small antenna;

[0024] FIG. 9 is a perspective view of the electrically small antenna with a first electrically reactive component to implement the second method of tuning the electrically small antenna;

[0025] FIG. 10 is a perspective view of the electrically small antenna with a second electrically reactive component to implement the second method of tuning the electrically small antenna;

[0026] FIG. 11 illustrates a listing of the steps of a third method of tuning an electrically small antenna;

[0027] FIG. 12 is a perspective view of the electrically small antenna with a capacitor and a varactor diode to implement the second method of tuning the electrically small antenna;

[0028] FIG. 13 illustrates a listing of the steps of a fourth method of tuning an electrically small antenna;

[0029] FIG. 14A is a perspective view of a first electrically small antenna and a second electrically small antenna to implement the fourth method of tuning the electrically small antenna;

[0030] FIG. 14B is a cross-sectional view, cut along a vertical plane, of the first electrically small antenna and the second electrically small antenna; and

[0031] FIG. 14C is a perspective view of the first electrically small antenna and the second electrically small antenna being rotated to implement the fourth method of tuning the electrically small antenna.

[0032] The drawing figures do not limit the current invention to the specific embodiments disclosed and described herein. The drawings are not necessarily to scale, emphasis instead being placed upon clearly illustrating the principles of the invention.

DETAILED DESCRIPTION OF THE EMBODIMENTS

[0033] The following detailed description of the technology references the accompanying drawings that illustrate specific embodiments in which the technology can be practiced. The embodiments are intended to describe aspects of the technology in sufficient detail to enable those skilled in the art to practice the technology. Other embodiments can be utilized and changes can be made without departing from the scope of the current invention. The following detailed description is, therefore, not to be taken in a limiting sense. The scope of the current invention is defined only by the appended claims, along with the full scope of equivalents to which such claims are entitled.

[0034] An electrically small antenna 10, constructed in accordance with various embodiments of the current invention, is shown in FIG. 1. The electrically small antenna 10 typically has small dimensions compared to a wavelength of a wireless signal the electrically small antenna 10 is configured to transmit and/or receive. Generally, a volume containing an electrically conductive, radiating element of the electrically small antenna 10 has a spherical diameter much less than the wavelength of the wireless signal. Thus, other configurations or types of antennas may be considered electrically small antennas as long as they meet this criterion.

[0035] The electrically small antenna 10 may be embodied by a hemispherical helical monopole antenna as shown in the left image of FIG. 1, or a spherical helical dipole antenna as shown in the right image of FIG. 1. The electrically small antenna 10 includes at least one radiating element 12 and a

support structure 14. The radiating element 12 is generally formed from electrically conductive material including metals and metal alloys and is configured to transmit and/or receive a wireless signal. The radiating element 12 may have an exemplary helical shape in a monopole configuration or a dipole configuration. The radiating element 12 may include a feed point at a first end and a pole at a second, opposing end. The support structure 14 is generally formed from electrically insulating or dielectric materials, including polymers, ceramics, fiberglass, etc. The support structure 14 may have a roughly hemispherical or roughly spherical shape, an oblate or prolate spheroid shape, or the like and may be solid with an outer surface or hollow with a wall including an inner surface and an outer surface. The radiating element 12 is positioned on the outer surface of the support structure 14. In some embodiments, the radiating element 12 may be formed separately and attached to the outer surface of the support structure 14. In other embodiments, the radiating element 12 may be printed or deposited and etched on the outer surface of the support structure 14. In yet other embodiments, the support structure 14 may be formed from a thermoplastic material doped with a (non-conductive) metallic inorganic compound activated by a laser utilizing a laser direct structuring process. The radiating element 12 may be formed by the laser striking the outer surface of the support structure 14 in the helical pattern, which activates the inorganic compound to become electrically conductive.

[0036] Referring to FIGS. 2, 3A, 3B, and 3C, a first method 100 of tuning the electrically small antenna 10 is illustrated. Referring to step 101, the method broadly comprises applying forces to the surfaces of the support structure 14 in the vicinity of the pole of the radiating element 12. The electrically small antenna 10 is shown in FIG. 3A with no forces applied to the support structure 14. (To illustrate the method 100, the hemispherical helical monopole antenna embodiment of the electrically small antenna 10 is shown. The method is implemented in a similar manner for the spherical helical dipole antenna embodiment of the electrically small antenna 10.) In this default state, the support structure 14 has a first height of H1. Shown in FIG. 3B, a first force is applied downward, as a push on the outer surface of the support structure 14 or as a pull on the inner surface of the support structure. The first force results in the support structure 14 having a second height of H2, which is less than H1. Shown in FIG. 3C, a second force is applied upward, as a push on the inner surface of the support structure 14 or a pull on the outer surface of the support structure 14. The second force results in the support structure 14 having a third height of H3, which is greater than H1. Other forces may be applied to the support structure in other locations or in other directions than those shown in FIGS. 3B and 3C, which may change other dimensions. Each force may change the shape or dimensions of the support structure 14, which in turn changes the shape or dimensions of the radiating element 12, which may increase or may decrease the frequency at which the radiating element 12 resonates—thereby tuning the electrically small antenna 10. The forces may be applied using manual techniques or automated techniques involving mechanisms, machines, and/or robots.

[0037] Referring to FIGS. 4A and 4B, a manual implementation of the first method 100 of tuning the electrically small antenna 10 is shown. A mechanism including a bolt 16 and a nut 18 assembly may be utilized to apply forces to the

support structure **14** to change its shape or dimensions. The bolt **16** may have outer threads, and the nut **18** may have complementary inner threads that couple with the threads of the bolt **16** in a known fashion. A planar surface or other object, such as a printed circuit board or the like, may retain the electrically small antenna **10**, such that a lower edge of the support structure **14** rests on the planar surface or upper surface of the planar object. In some embodiments as shown in FIG. 4A, the bolt **16** is positioned in an opening in the support structure **14** such that a head of the bolt **16** is coupled to the support structure **14** near its apex in the vicinity of the pole of the radiating element **12**. The other end of the bolt **16** is positioned in an opening in the planar object aligned with a center of the support structure **14**. The nut **18** may be coupled to the bolt **16** on the opposing side of the planar surface and coupled thereto. In other embodiments as shown in FIG. 4B, the bolt **16** is positioned in an opening in the planar object, with the head of the bolt **16** positioned on and coupled to a lower surface of the planar object. The other end of the bolt **16** extends through an opening in the support structure **14** near its apex in the vicinity of the pole of the radiating element **12**. The nut **18** is attached to the bolt **16** and coupled to the support structure **14**.

[0038] Rotation of the bolt **16** and/or the nut **18** generally causes axial motion of the nut **18** along the bolt **16**. But, given that the nut **18** and the head of the bolt **16** are coupled to the planar object and the support structure **14**, respectively in some embodiments, and to the support structure **14** and the planar object, respectively in other embodiments, rotation of the bolt **16** and/or the nut **18** in a first direction exerts an upward force on the support structure **14**, which may increase its height. Rotation of the bolt **16** and/or the nut **18** in a second direction, opposite the first direction, exerts a downward force on the support structure **14**, which may decrease its height. The forces may change the shape or dimensions of the support structure **14**, which in turn changes the shape or dimensions of the radiating element **12**, which may increase or may decrease the frequency at which the radiating element **12** resonates—thereby tuning the electrically small antenna **10**.

[0039] Referring to FIGS. 5A, 5B, and 5C, an automated implementation of the first method **100** of tuning the electrically small antenna **10** is shown. A mechanism including a servo controlled actuator **20** may be utilized to automatically apply forces to the support structure **14** to change its shape or dimensions. The actuator **20** may include a body **22** and an arm **24**. The body **22** may have a generally cylindrical shape and may house a servo motor or similar device which is able to, or configured to, adjust a length or extension of the arm **24**. The arm **24** is typically cylindrical or rod shaped and is telescopically coupled to the body **22** such that the arm **24** extends from and retracts into the body **22**. The actuator **20** may be positioned on a planar surface or other object that is retaining the electrically small antenna **10**. Specifically, the body **22** of the actuator **20** may be positioned on the planar surface while the arm **24** is fixedly coupled to the inner surface of the support structure **14**. The actuator **20** is configured, or adjusted, such that the arm **24** is in a neutral position with respect to the body **22**, as shown in FIG. 5A. And, the support structure **14** has a first height of H1. The arm **24** is retracted into the body **22** at least partially, which applies a downward force and pulls on the support structure **14**, as shown in FIG. 5B. The support structure **14** has a second height of H2, which is less than H1. The arm **24** is

extended from the body **22** at least partially, which applies an upward force and pushes on the support structure **14**, as shown in FIG. 5C. The support structure **14** has a third height of H3, which is greater than H1. As mentioned above, the changes in shape or dimensions of the support structure **14** result in changes in shape or dimensions of the radiating element **12**, which may increase or may decrease the frequency at which the radiating element **12** resonates—thereby tuning the electrically small antenna **10**.

[0040] Referring to FIG. 6, another variation of the first method **100** of tuning the electrically small antenna **10** involves applying thermal energy, or heat, to the support structure **14**. A heat source **26** generally provides the thermal energy. The heat source **26** may be external to the electrically small antenna **10**, but in close proximity thereto. Or, the heat source **26** may be integrated with the electrically small antenna **10** such as a current carrying wire or resistive element embedded in, or coupled to, the support structure **14**. Current flow through the wire or resistive element generates heat. The heat generated from the heat source **26** results in expansion of the material of the support structure **14** that varies according to a coefficient of thermal expansion for the material. Expansion of the support structure **14** changes the shape or dimensions of the radiating element **12**, which may increase or may decrease the frequency at which the radiating element **12** resonates—thereby tuning the electrically small antenna **10**.

[0041] Referring to FIGS. 7A and 7B, yet another variation of the first method **100** of tuning the electrically small antenna **10** involves applying a torsional, or twisting, force to the support structure **14**. A first force in a first direction, such as counterclockwise, may be applied, as shown in FIG. 7A, near the apex of the support structure **14**, while a second force in a second direction, such as clockwise, may be applied to the base of the support structure **14**. In other embodiments, the first direction may be clockwise, while the second direction may be counterclockwise. Alternatively, the base of the support structure **14** may be rigidly attached to a planar surface or other object that holds the base of the support structure **14** in a fixed position, as shown in FIG. 7B. And, a force may be applied near the apex of the support structure **14** in either a clockwise or a counterclockwise direction. In either implementation of the fifth method, the support structure **14** is twisted such that the shape or dimension of the radiating element **12** changes, which may increase or may decrease the frequency at which the radiating element **12** resonates—thereby tuning the electrically small antenna **10**.

[0042] Referring to FIGS. 8A, 8B, 9, and 10, a second method **200** of tuning the electrically small antenna **10** is illustrated. At least a portion of the steps of the method **200** are listed in FIGS. 8A and 8B. The steps may be performed in the order shown in FIGS. 8A and 8B, or they may be performed in a different order. Furthermore, some steps may be performed concurrently as opposed to sequentially. In addition, some steps may be optional or may not be performed. The method **200** broadly involves passive electronic and mechanical tuning. Referring to step **201**, the electrically small antenna **10** may be retained on a planar surface or other object. An electrically reactive component **28**, a bolt **30**, and a nut **32** are also included to implement the method **200**. In some embodiments, the electrically reactive component **28** is a capacitor, as shown in FIG. 9. In other embodiments, the electrically reactive component **28** is an

inductor, as shown in FIG. 10. The bolt 30 and the nut 32 are similar in structure to bolt 16 and the nut 18 described above. Alternatively, bolt 30 and nut 32 could be replaced with other mechanical means including, for example, the actuator 20. Referring to steps 202 and 203, the bolt 30 is positioned in an opening in the planar surface, and the nut 32 is coupled to the bolt 30 as well as the planar surface. The bolt 30 may also be electrically connected to electrical ground. Referring to step 204, a first terminal of the electrically reactive component 28 is electrically and mechanically connected to the pole of the radiating element 12. Referring to step 205, a second terminal of the electrically reactive component 28 is electrically and mechanically connected to the bolt 30. Referring to step 206, rotation of the bolt 30 and/or the nut 32 generally causes axial motion of the nut 32 along the bolt 30. But, given that the nut 32 is coupled to the planar surface, rotation of the bolt 30 and/or the nut 32 results in axial motion of the bolt 30 with respect to the planar surface. And, given that the end of the bolt 30 is mechanically connected to the electrically reactive component 28, rotation of the bolt 30 and/or the nut 32 and the resulting axial motion of the bolt 30 apply either a tension force or a compression force, depending on direction of motion, to the electrically reactive component 28. For example, a first direction of axial motion, such as down, of the bolt 30 applies a tension force to the electrically reactive component 28. A second direction of axial motion, such as up, of the bolt 30 applies a compression force to the electrically reactive component 28. Each of the tension force and the compression force applied to the electrically reactive component 28 changes the shape and/or dimension of the electrically reactive component 28. For example, the forces may change a separation distance or orientation of parallel plates forming the capacitor, which in turn may vary the capacitance. The forces may change a length or cross-sectional area of a coil which forms the inductor, thereby changing its inductance. Changes in the capacitance and/or the inductance changes the reactance of the electrically reactive component 28. Further, changes in the voltage applied across the electrically reactive component 28 changes the reactance of the electrically reactive component 28. For example, increasing or decreasing the voltage changes the capacitance even if the distance or orientation of parallel plates is not changed. Similarly, increasing or decreasing the voltage changes the inductance even if the length or cross-sectional area of the coil is not changed. A change in reactance of the electrically reactive component 28 may be achieved by changing the voltage, applying forces to the electrically reactive component 28, or doing both. Without departing from the scope of the invention, the electrically reactive component 28 could be located on an alternative structure that does not produce forces where altering the voltage may be the means for changing the reactance of the electrically reactive component 28. Changes in the reactance of the electrically reactive component 28 may increase or may decrease the frequency at which the radiating element 12 (to which the electrically reactive component 28 is electrically connected) resonates—thereby tuning the electrically small antenna 10.

[0043] Referring to FIGS. 11 and 12, a third method 300 of tuning the electrically small antenna 10 is illustrated. At least a portion of the steps of the method 200 are listed in FIG. 11. The steps may be performed in the order shown in FIG. 11, or they may be performed in a different order. Furthermore, some steps may be performed concurrently as

opposed to sequentially. In addition, some steps may be optional or may not be performed. The method 300 broadly involves active electronic tuning. The electrically small antenna 10 may optionally be retained on a planar surface or other object. A varactor diode 34 and a capacitor 36, as shown in FIG. 12, are also included to implement the method 300. The varactor diode 34 is an active device variable capacitance diode or a voltage controlled capacitor. Thus, the capacitance of the device may vary according to the voltage across it. Referring to step 301, a first terminal of the capacitor 36 is electrically connected to the pole of the radiating element 12. Referring to steps 302 and 303, a cathode of the varactor diode 34 is electrically connected to a positive voltage source, and an anode of the varactor diode 34 is electrically connected to a second terminal of the capacitor 36. Referring to step 304, the feed point of the radiating element 12 is electrically connected to a negative voltage source. Referring to step 305, the voltage values of the positive voltage source and the negative voltage source may be adjusted in order to control the voltage across the varactor diode 34, which in turn adjusts the capacitance. Changes in the capacitance of the varactor diode 34 may increase or may decrease the frequency at which the radiating element 12 (to which the varactor diode 34 is electrically connected) resonates—thereby tuning the electrically small antenna 10.

[0044] Referring to FIGS. 13, 14A, 14B, and 14C, a fourth method 400 of tuning a first electrically small antenna 500 is illustrated. At least a portion of the steps of the method 400 are listed in FIG. 13. The steps may be performed in the order shown in FIG. 13, or they may be performed in a different order. Furthermore, some steps may be performed concurrently as opposed to sequentially. In addition, some steps may be optional or may not be performed. The method 400 broadly involves placing a second electrically small antenna 510 that is either larger or smaller than the first electrically small antenna 500 either outside or inside the first electrically small antenna 500. Referring to step 401, the first electrically small antenna 500 is substantially similar to the electrically small antenna 10 and includes a first radiating element 502 and a first support structure 504. The second electrically small antenna 510 includes a second radiating element 512 and a second support structure 514, which are functionally equivalent to the radiating element 12 and the support structure 14, respectively. In some embodiments such as those shown in FIG. 14A, the second radiating element 512 has a length that is less than the length of the first radiating element 502, and the second support structure 514 has a radius, or other dimension, that is less than the radius, or other dimension, of the first support structure 504. As highlighted in the cross section of FIG. 14B, the second electrically small antenna 510 is positioned in the interior of the first electrically small antenna 500 such that an inner surface of the first support structure 504 is spaced apart from and surrounds the outer surface of the second support structure 514. The base of the second support structure 514 is generally aligned with the base of the first support structure 504. In other embodiments, the second radiating element 512 has a length that is greater than the length of the first radiating element 502, and the second support structure 514 has a radius, or other dimension, that is greater than the radius, or other dimension, of the first support structure 504. The second electrically small antenna 510 is positioned on the outside of the first electrically small antenna 500 such

that an inner surface of the second support structure **514** surrounds the outer surface of the first support structure **504** and the base of the second support structure **514** is generally aligned with the base of the first support structure **504**.

[0045] The first electrically small antenna **500** may be driven with an electronic signal, while the second electrically small antenna **510** may be passive and may not receive an electronic signal. Alternatively, the first radiating element **502** may be electrically connected to the second radiating element **512**. Referring to step **402**, in either situation, the second electrically small antenna **510** is rotated along its base, as shown in FIG. **14C**, such that the base of the second support structure **514** is either aligned, or not aligned, with the base of the first support structure **504**. The second electrically small antenna **510** is rotated along its base in either a clockwise direction or a counterclockwise direction. Alternatively, the first electrically small antenna **500** may be rotated along its base. Or, the first electrically small antenna **500** and the second electrically small antenna **510** may each be rotated in directions opposing one another. Driving at least the first electrically small antenna **500** with an electronic signal results in an inductive and/or magnetic coupling between the first radiating element **502** and the second radiating element **512**. The rotation of one electrically small antenna **500**, **510** relative to the other electrically small antenna **500**, **510** changes the relative position of the radiating elements **502**, **512** and results in a change in the amount of inductive and/or magnetic coupling between the first radiating element **502** and the second radiating element **512**. Changes in the amount of inductive and/or magnetic coupling may increase or may decrease the frequency at which the first radiating element **502** resonates—thereby tuning the electrically small antenna **500**.

[0046] Additional Considerations

[0047] Throughout this specification, references to “one embodiment”, “an embodiment”, or “embodiments” mean that the feature or features being referred to are included in at least one embodiment of the technology. Separate references to “one embodiment”, “an embodiment”, or “embodiments” in this description do not necessarily refer to the same embodiment and are also not mutually exclusive unless so stated and/or except as will be readily apparent to those skilled in the art from the description. For example, a feature, structure, act, etc. described in one embodiment may also be included in other embodiments, but is not necessarily included. Thus, the current invention can include a variety of combinations and/or integrations of the embodiments described herein.

[0048] Although the present application sets forth a detailed description of numerous different embodiments, it should be understood that the legal scope of the description is defined by the words of the claims set forth at the end of this patent and equivalents. The detailed description is to be construed as exemplary only and does not describe every possible embodiment since describing every possible embodiment would be impractical. Numerous alternative embodiments may be implemented, using either current technology or technology developed after the filing date of this patent, which would still fall within the scope of the claims.

[0049] Throughout this specification, plural instances may implement components, operations, or structures described as a single instance. Although individual operations of one or more methods are illustrated and described as separate

operations, one or more of the individual operations may be performed concurrently, and nothing requires that the operations be performed in the order illustrated. Structures and functionality presented as separate components in example configurations may be implemented as a combined structure or component. Similarly, structures and functionality presented as a single component may be implemented as separate components. These and other variations, modifications, additions, and improvements fall within the scope of the subject matter herein.

[0050] As used herein, the terms “comprises,” “comprising,” “includes,” “including,” “has,” “having” or any other variation thereof, are intended to cover a non-exclusive inclusion. For example, a process, method, article, or apparatus that comprises a list of elements is not necessarily limited to only those elements but may include other elements not expressly listed or inherent to such process, method, article, or apparatus.

[0051] The patent claims at the end of this patent application are not intended to be construed under 35 U.S.C. § 112(f) unless traditional means-plus-function language is expressly recited, such as “means for” or “step for” language being explicitly recited in the claim(s).

[0052] Although the technology has been described with reference to the embodiments illustrated in the attached drawing figures, it is noted that equivalents may be employed and substitutions made herein without departing from the scope of the technology as recited in the claims.

[0053] Having thus described various embodiments of the technology, what is claimed as new and desired to be protected by Letters Patent includes the following:

1. A method of tuning an electrically small antenna comprising a radiating element and a support structure supporting the radiating element, the method comprising:
 - positioning the electrically small antenna on an object;
 - attaching a first component of a mechanism to the support structure;
 - attaching a second component of the mechanism to the object; and
 - applying a mechanical action to the first component, the second component, or both to exert a force on the support structure to change a shape or a dimension of the radiating element to increase or decrease a frequency at which the electrically small antenna resonates.
2. The method of claim **1**, wherein the mechanism includes an actuator, the first component includes an arm of the actuator attached to the support structure, the second component includes a body of the actuator attached to an upper surface of the object, and the mechanical action includes extension of the arm from the body or retraction of the arm into the body.
3. The method of claim **1**, wherein the mechanism includes an actuator, the first component includes an arm of the actuator attached to an upper surface of the object, the second component includes a body of the actuator attached to the support structure, and the mechanical action includes extension of the arm from the body or retraction of the arm into the body.
4. The method of claim **1**, wherein the mechanism includes a bolt and nut assembly, the first component includes a head of the bolt, the second component includes the nut positioned in contact with a lower surface of the

object, and the mechanical action includes rotation of the head of the bolt, the nut, or both.

5. The method of claim **1**, wherein the mechanism includes a bolt and nut assembly, the first component includes the nut, the second component includes a head of the bolt positioned in contact with a lower surface of the object, and the mechanical action includes rotation of the head of the bolt, the nut, or both.

6. The method of claim **1**, wherein the object includes a roughly planar surface on which the electrically small antenna is positioned.

7. A method of tuning an electrically small antenna comprising a radiating element and a support structure supporting the radiating element, the method comprising:

- positioning the electrically small antenna on an object;
- positioning a bolt through a first opening in the support structure and a second opening in the object;
- attaching a head of the bolt to the support structure, positioning a nut on the bolt, and attaching the nut to the object, or attaching the head of the bolt to the object, positioning the nut on the bolt, and attaching the nut to the support structure; and
- rotating the bolt, the nut, or both to apply a force to the support structure.

8. The method of claim **7**, wherein the force is applied to the support structure to change a shape or a dimension of the radiating element to increase or decrease a frequency at which the electrically small antenna resonates.

9. The method of claim **7**, wherein the object includes a roughly planar surface on which the electrically small antenna is positioned.

10. The method of claim **7**, wherein the support structure has a hemispheric shape including a circumferential base and an apex, and the base is attached to the object and the apex is attached to the head of the bolt or the nut.

11. The method of claim **7**, wherein the support structure has a hemispheric shape including a circumferential base and an apex, and a first end of the radiating element is positioned proximal to the apex, and a second end of the radiating element is positioned proximal to the base.

12. The method of claim **11**, wherein the first end of the radiating element is a feed point and the second end of the radiating element is a pole.

13. The method of claim **11**, wherein the first end of the radiating element is a pole and the second end of the radiating element is a feed point.

14. The method of claim **7**, wherein the support structure has a hemispheric shape including a circumferential base and an apex, and the radiating element is positioned on an outer surface of the support structure and has a helical shape.

15. The method of claim **7**, further comprising:
removing the bolt and nut from the support structure and the object;

- positioning the nut on the bolt;
- positioning the bolt through the opening in the object and coupling the nut to the object;
- electrically connecting a first terminal of an electrically reactive component to a pole of the radiating element;
- electrically connecting a second terminal of the electrically reactive component to an end of the bolt; and
- rotating the bolt, the nut, or both to change a dimension of the electrically reactive component to increase or decrease a frequency at which the electrically small antenna resonates.

16. A method of tuning an electrically small antenna comprising a radiating element and a support structure supporting the radiating element, the method comprising:

- positioning the electrically small antenna on an object;
- positioning a nut on a bolt;
- positioning the bolt through a first opening in the object and coupling the nut to the object;
- electrically connecting a first terminal of an electrically reactive component to a pole of the radiating element;
- electrically connecting a second terminal of the electrically reactive component to an end of the bolt; and
- rotating the bolt, the nut, or both to change a dimension of the electrically reactive component to increase or decrease a frequency at which the electrically small antenna resonates.

17. The method of claim **16**, further comprising electrically connecting the bolt to electrical ground.

18. The method of claim **16**, wherein the electrically reactive component is a capacitor.

19. The method of claim **16**, wherein the electrically reactive component is an inductor.

20. The method of claim **16**, wherein the electrically small antenna is a hemispherical helical monopole antenna.

* * * * *