



(19) **United States**

(12) **Patent Application Publication**  
**Shultz et al.**

(10) **Pub. No.: US 2024/0237928 A1**

(43) **Pub. Date: Jul. 18, 2024**

(54) **METHOD FOR NON-INVASIVE MONITORING OF FLUORESCENT TRACER AGENT WITH DIFFUSE REFLECTING MEDIUM WITH TIME-VARYING OPTICAL PROPERTIES**

**Publication Classification**

- (51) **Int. Cl.**  
*A61B 5/1455* (2006.01)  
*A61B 5/00* (2006.01)  
*A61B 5/20* (2006.01)  
*G01J 1/04* (2006.01)  
*G01J 1/44* (2006.01)
- (52) **U.S. Cl.**  
 CPC ..... *A61B 5/1455* (2013.01); *A61B 5/0071* (2013.01); *A61B 5/201* (2013.01); *A61B 5/6832* (2013.01); *A61B 5/7235* (2013.01); *A61B 5/742* (2013.01); *G01J 1/0407* (2013.01); *G01J 1/44* (2013.01); *A61B 2560/0242* (2013.01); *A61B 2562/0242* (2013.01)

(71) Applicant: **MediBeacon Inc.**, St. Louis, MO (US)

(72) Inventors: **Kimberly Shultz**, Mountain View, CA (US); **Jennifer Keating**, Mountain View, CA (US); **Edward Solomon**, Menlo Park, CA (US); **Kate Bechtel**, Pleasant Hill, CA (US)

(21) Appl. No.: **18/583,363**

(22) Filed: **Feb. 21, 2024**

**Related U.S. Application Data**

- (63) Continuation of application No. 17/932,713, filed on Sep. 16, 2022, now Pat. No. 11,950,907, which is a continuation of application No. 17/200,381, filed on Mar. 12, 2021, now Pat. No. 11,478,172, which is a continuation of application No. 16/717,436, filed on Dec. 17, 2019, now Pat. No. 10,980,459, which is a continuation of application No. 15/884,365, filed on Jan. 30, 2018, now Pat. No. 10,548,521.
- (60) Provisional application No. 62/452,025, filed on Jan. 30, 2017.

(57) **ABSTRACT**

A method of assessment of renal function by monitoring a time-varying fluorescence signal emitted from a fluorescent agent from within a diffuse reflecting medium with time-varying optical properties is provided that includes using a renal monitoring system comprising at least one light source, at least one light detector, at least one optical filter, and at least one controller to provide a measurement data set comprising a plurality of measurement entries, each measurement data entry comprising at least two measurements obtained at one data acquisition time from a patient before and after administration of the fluorescent agent.

236

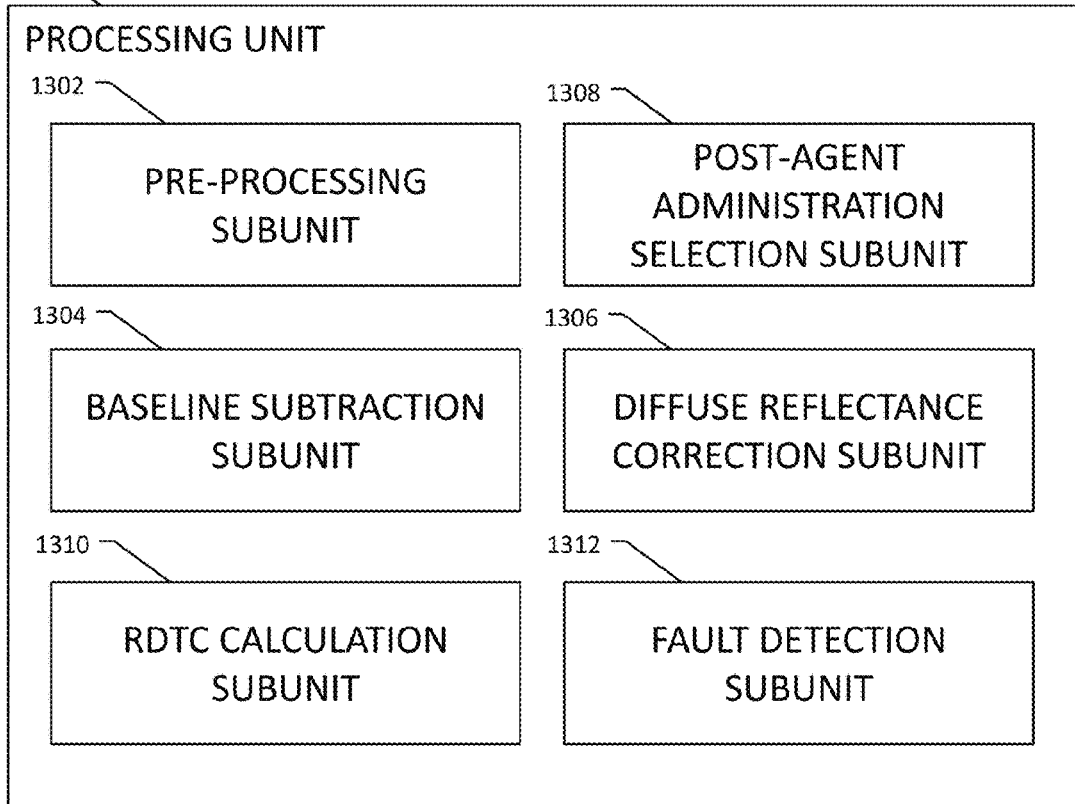

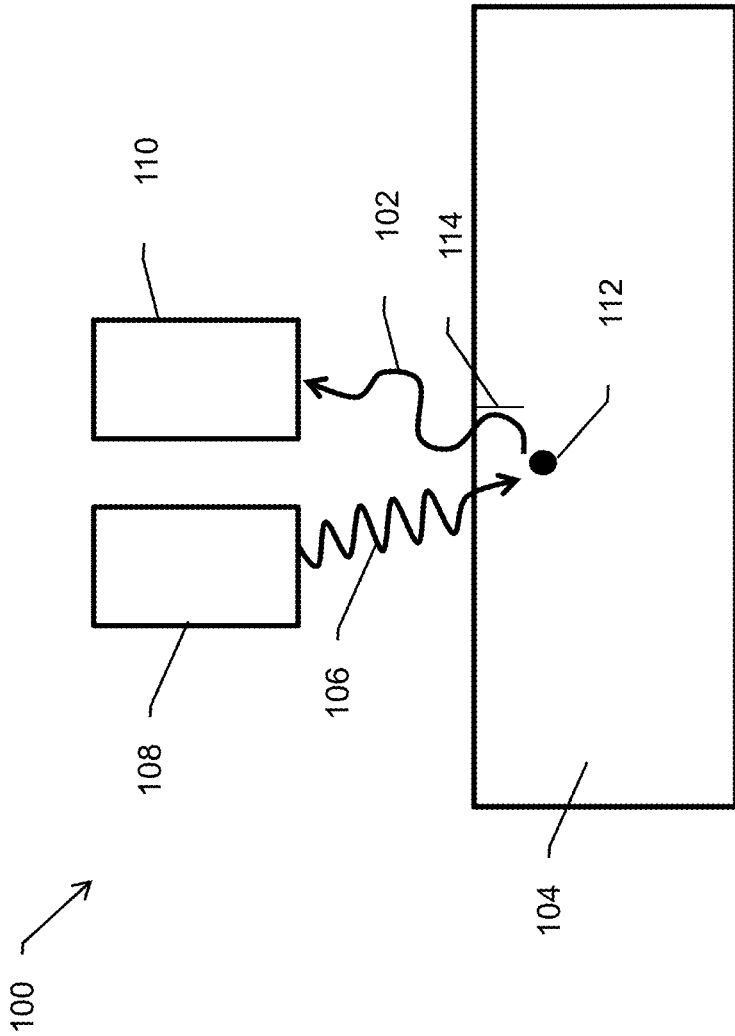

FIG. 1

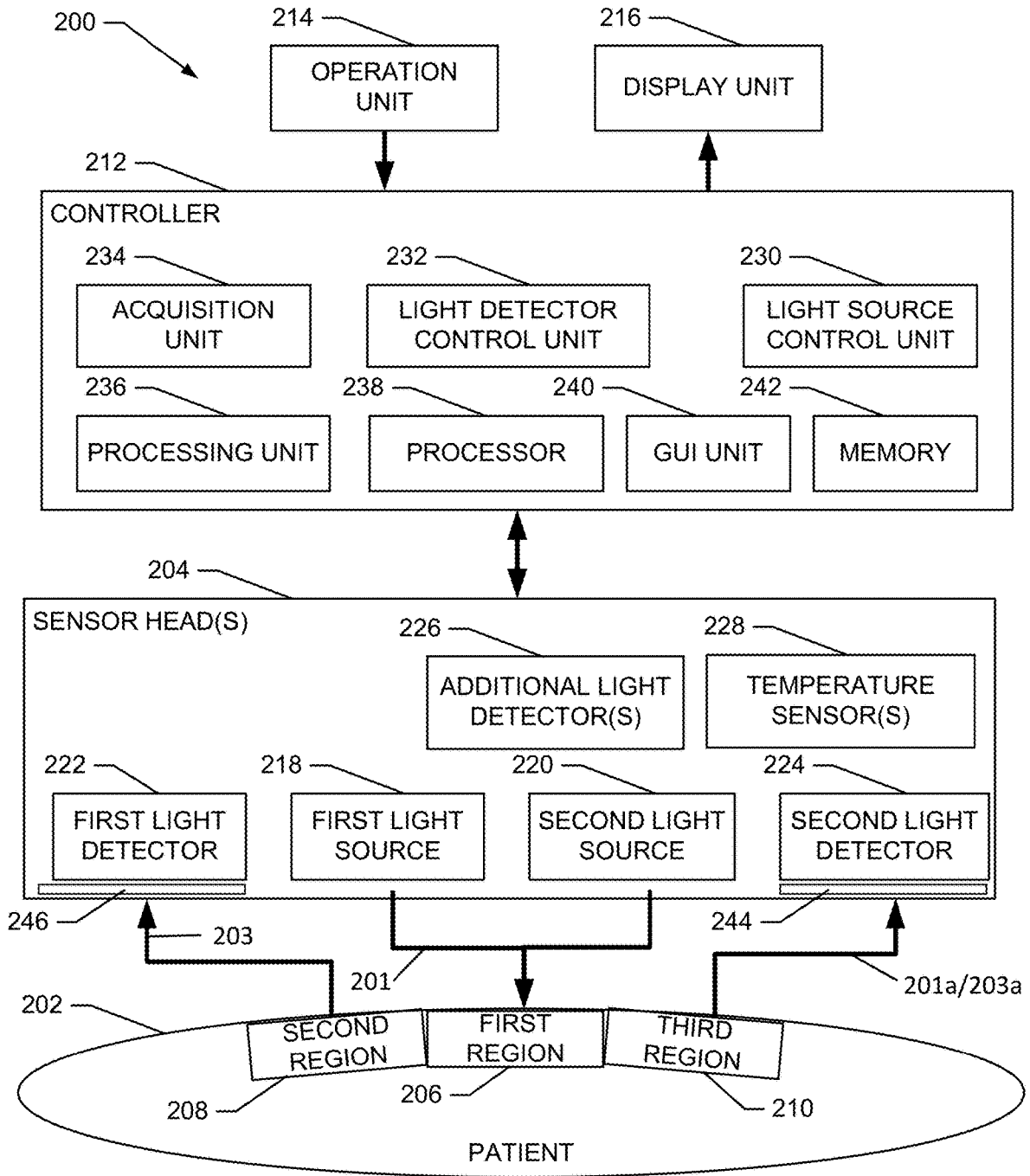

FIG. 2

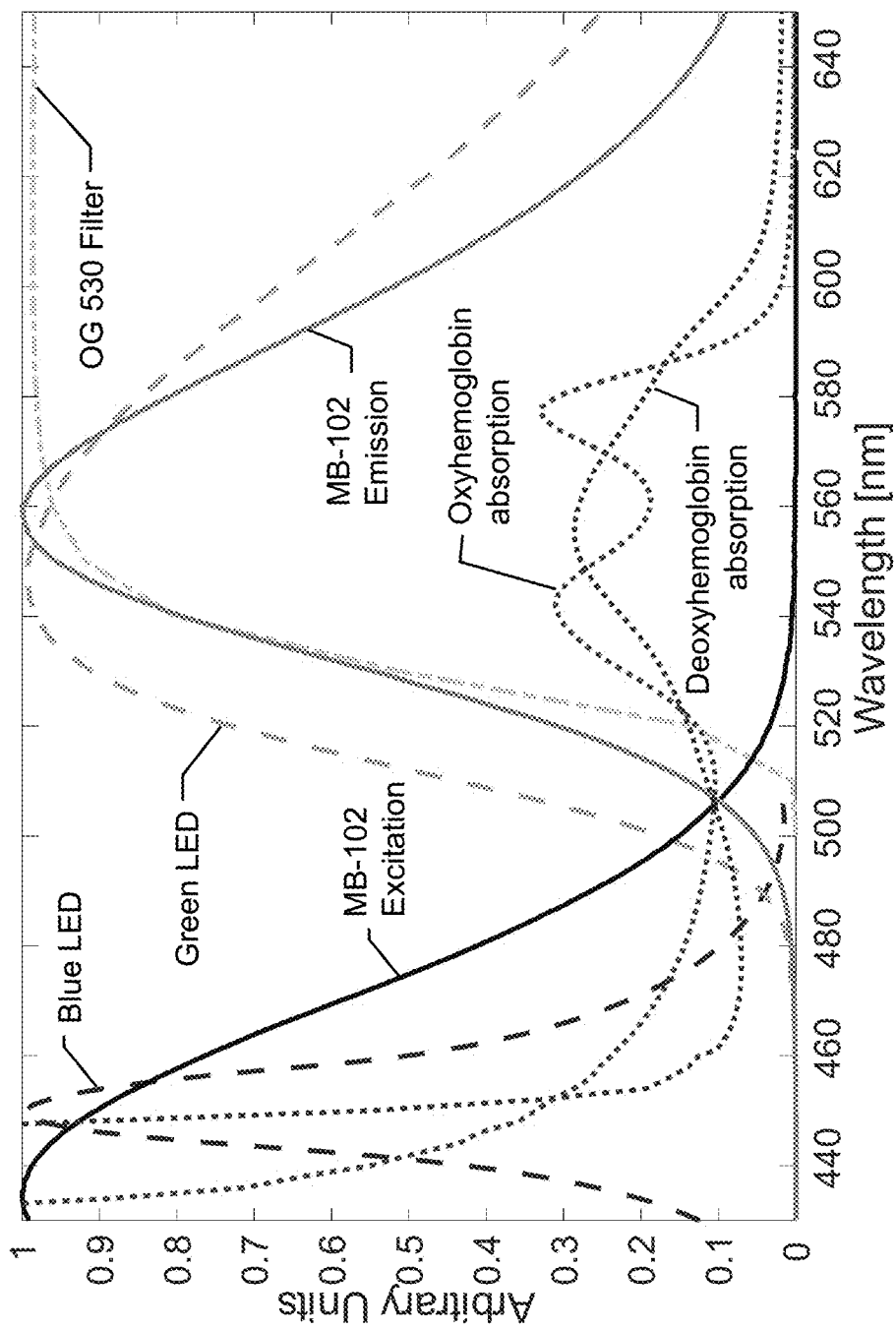

FIG. 3

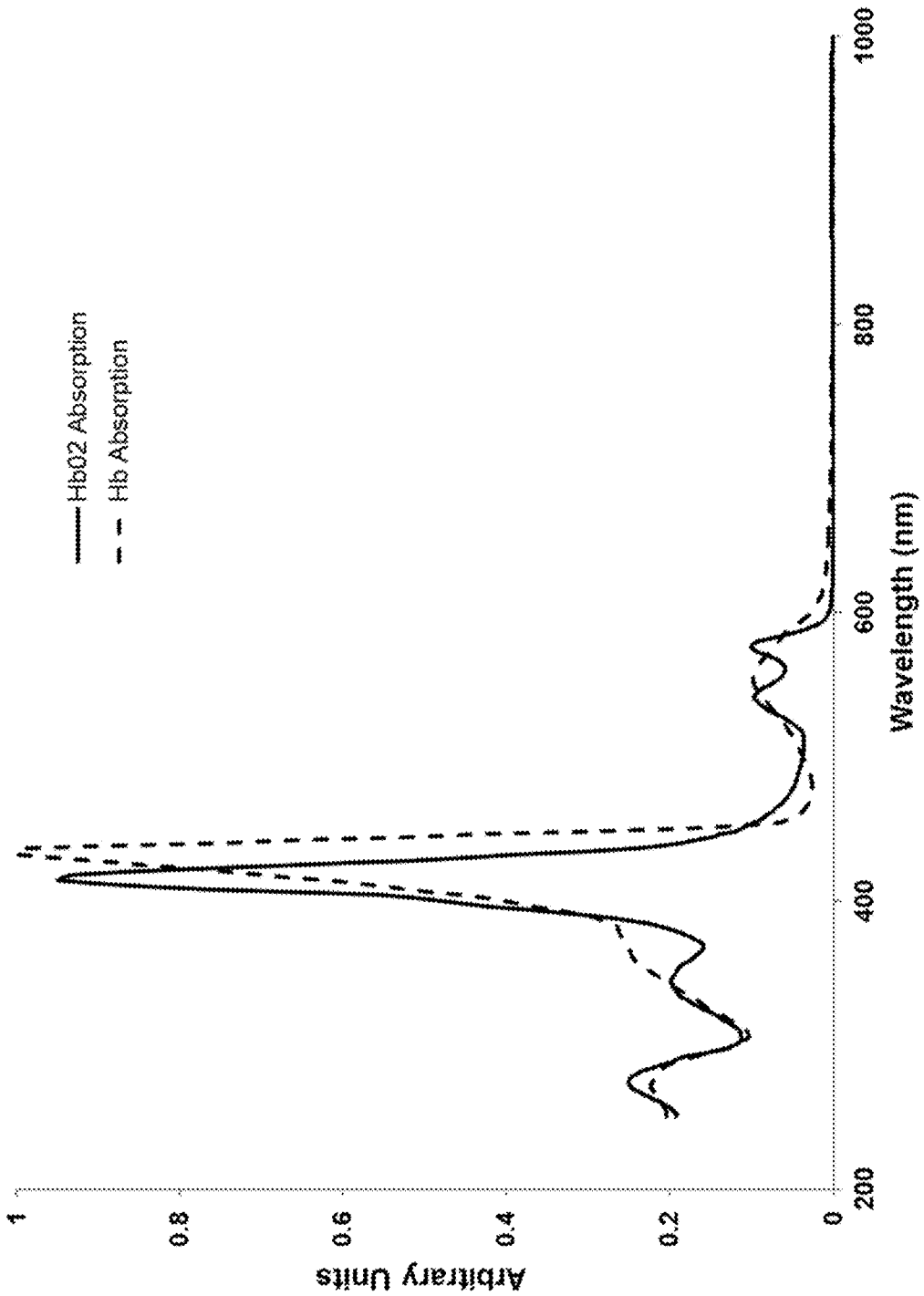

FIG. 4

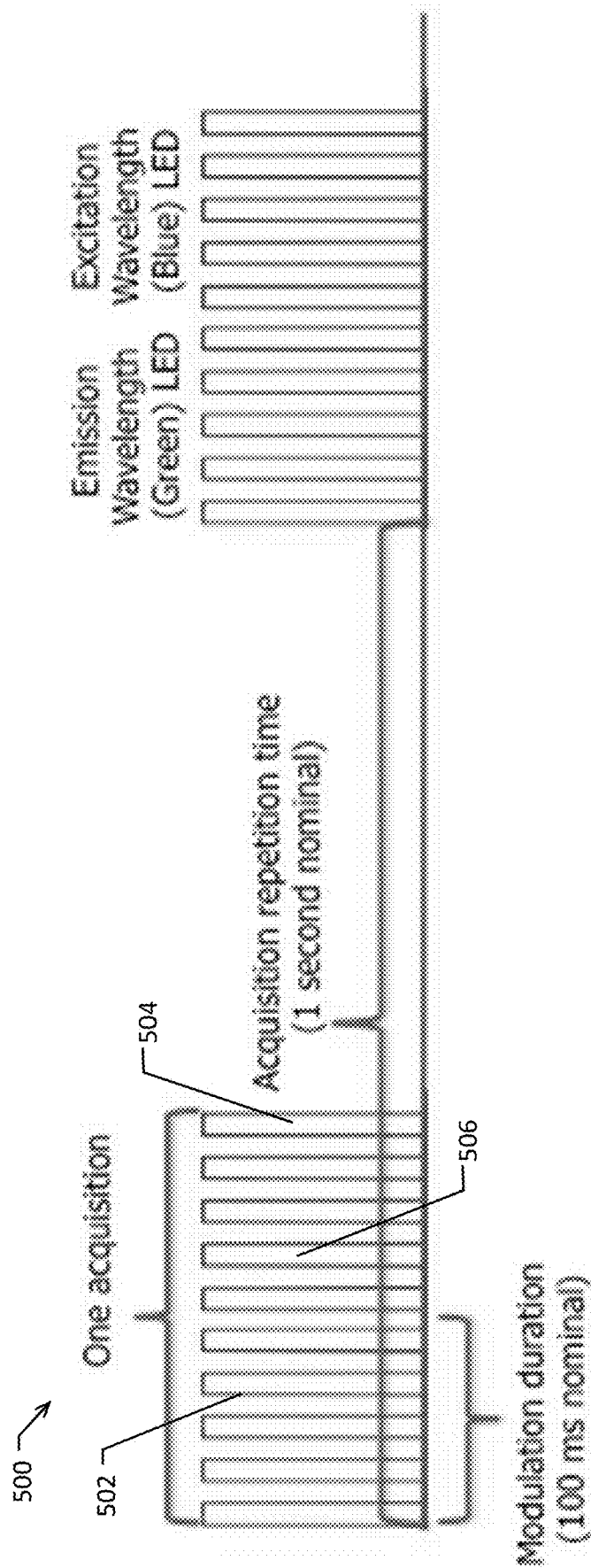

FIG. 5

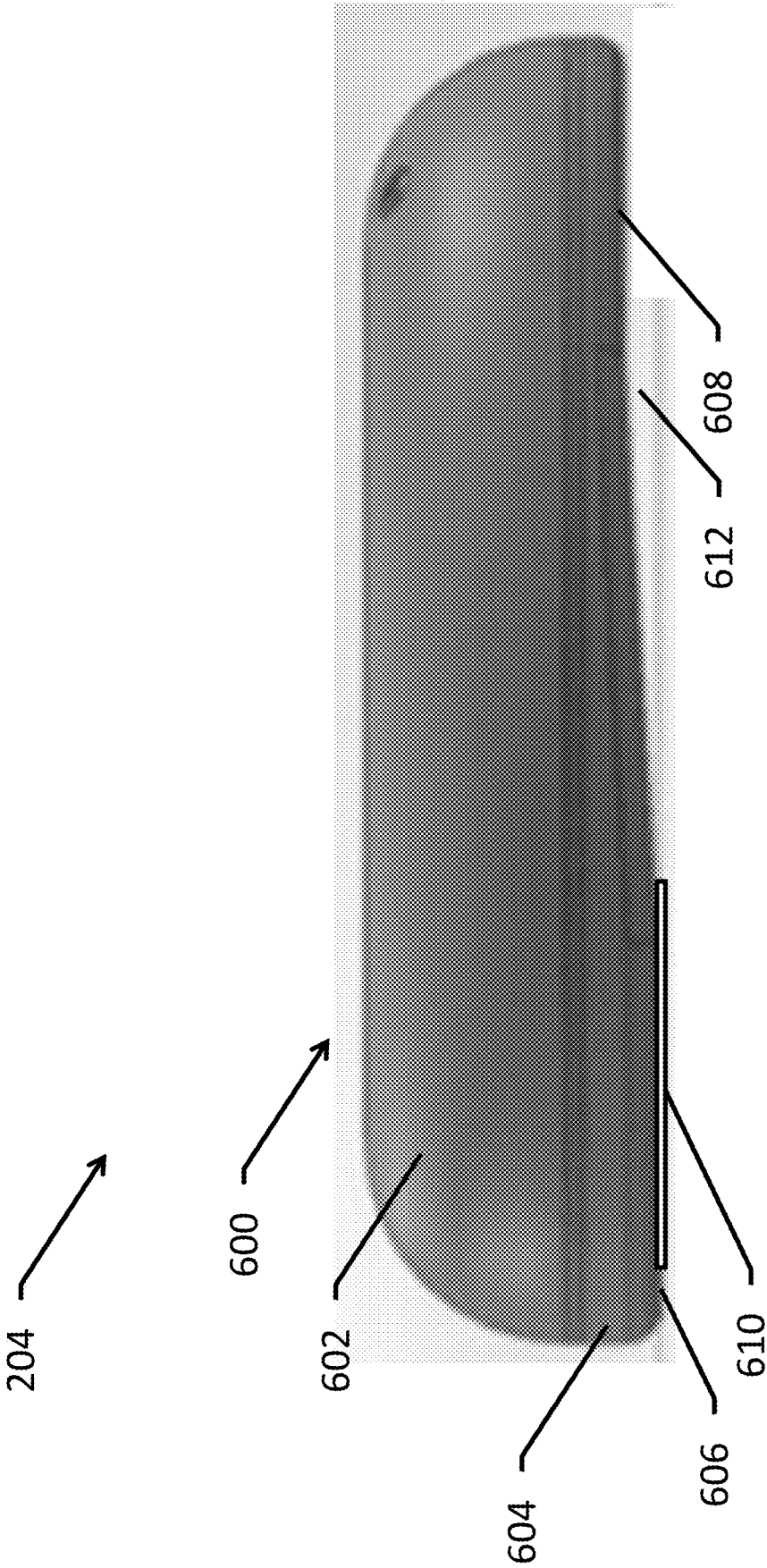

FIG. 6

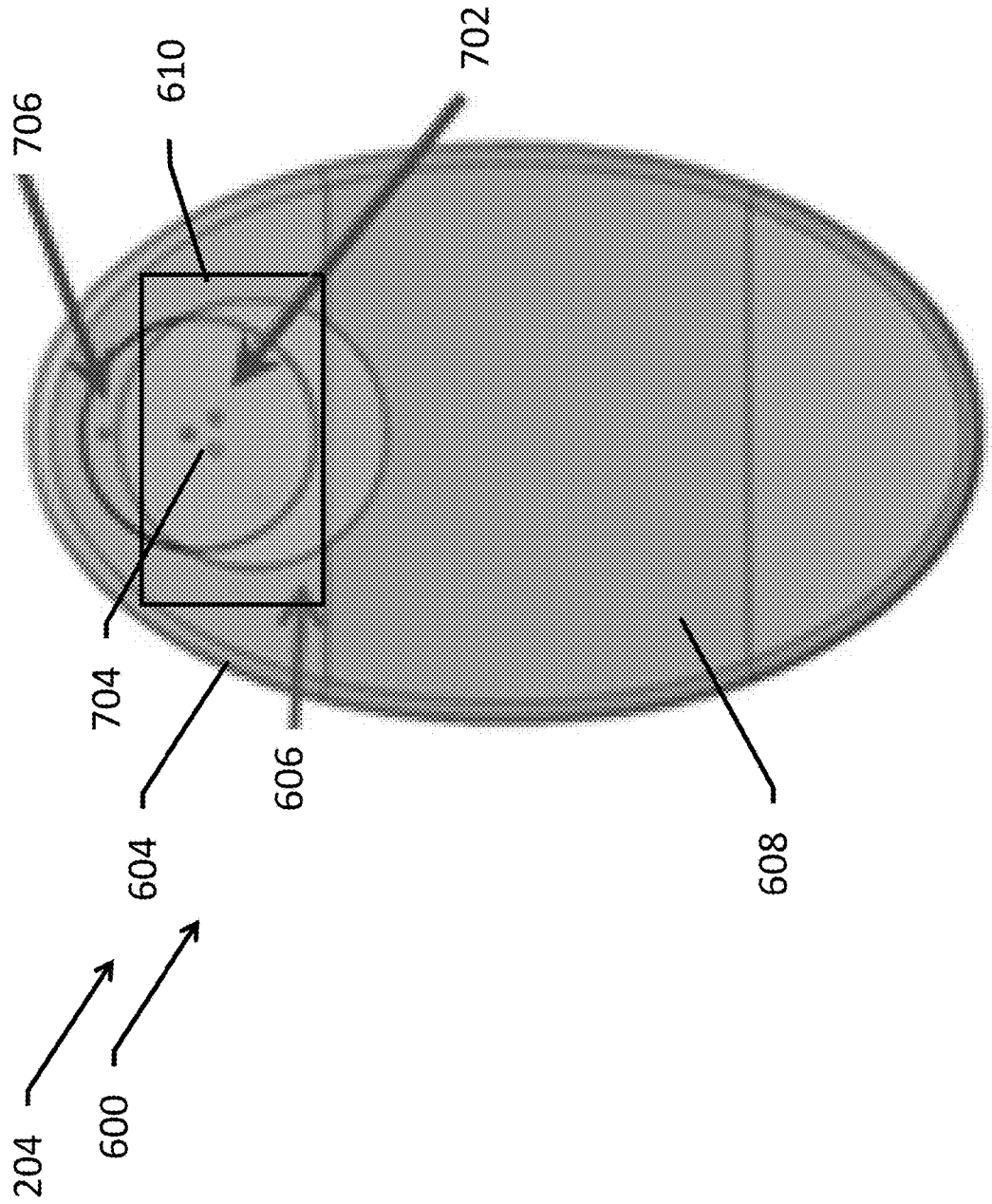

FIG. 7



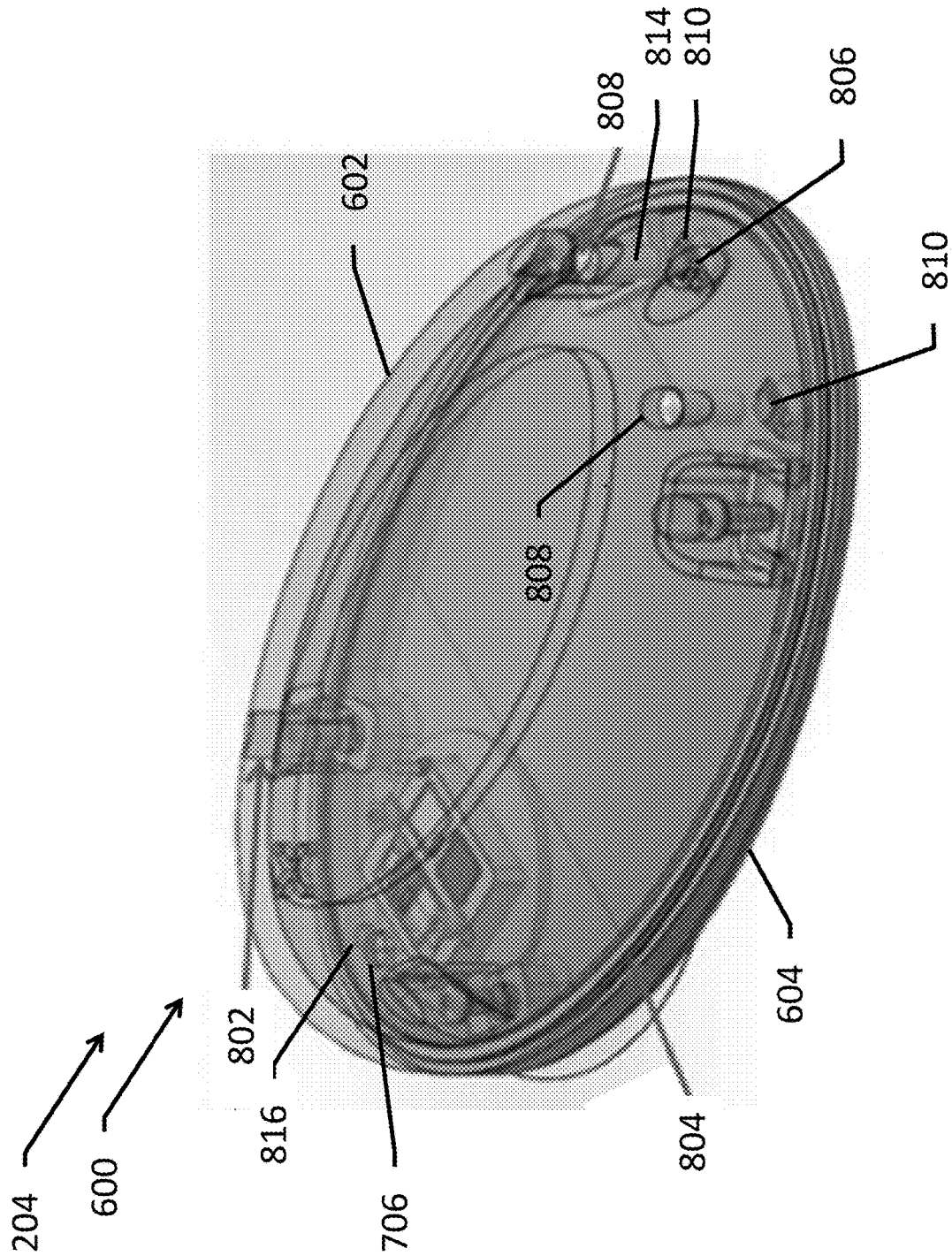

FIG. 8

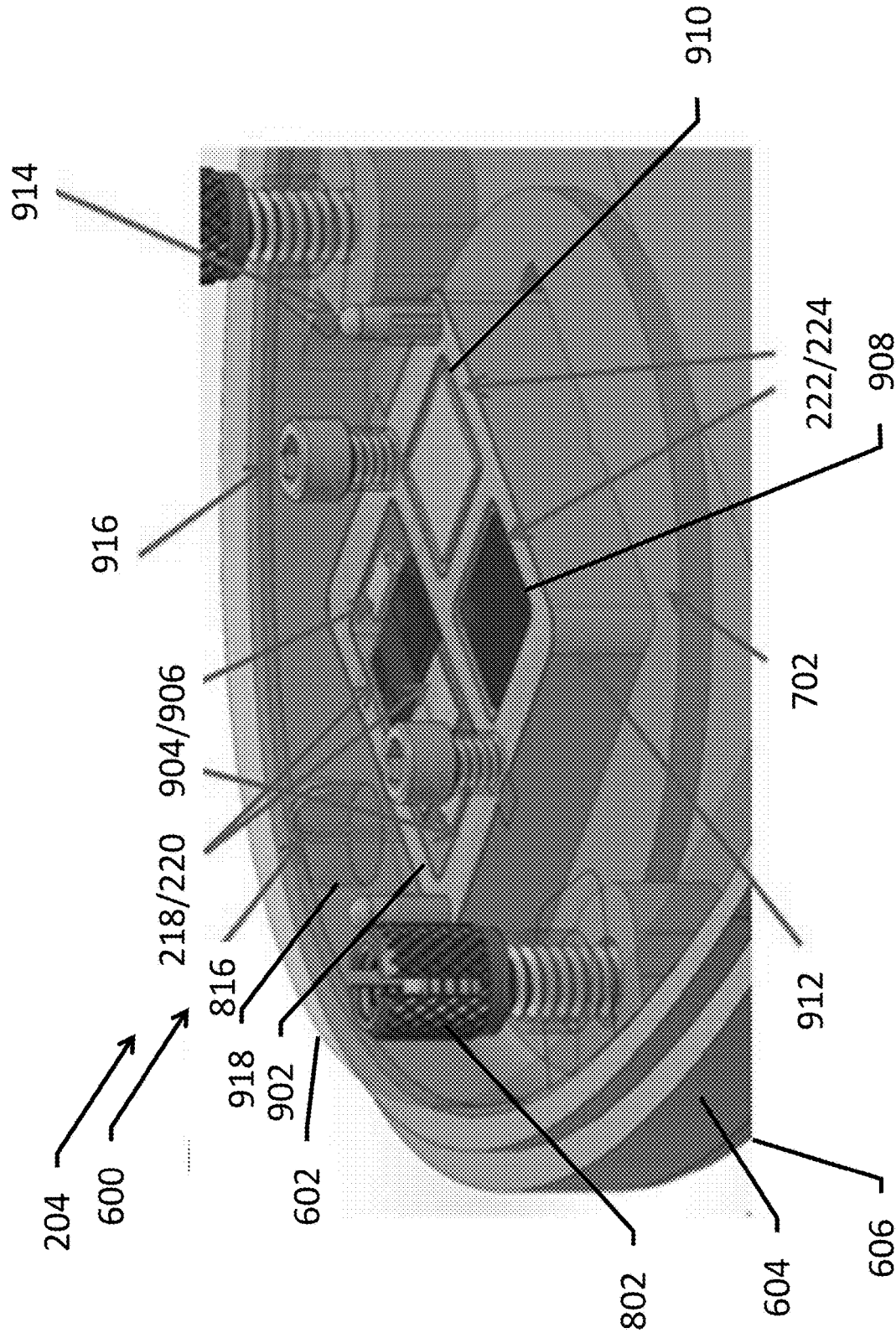

FIG. 9

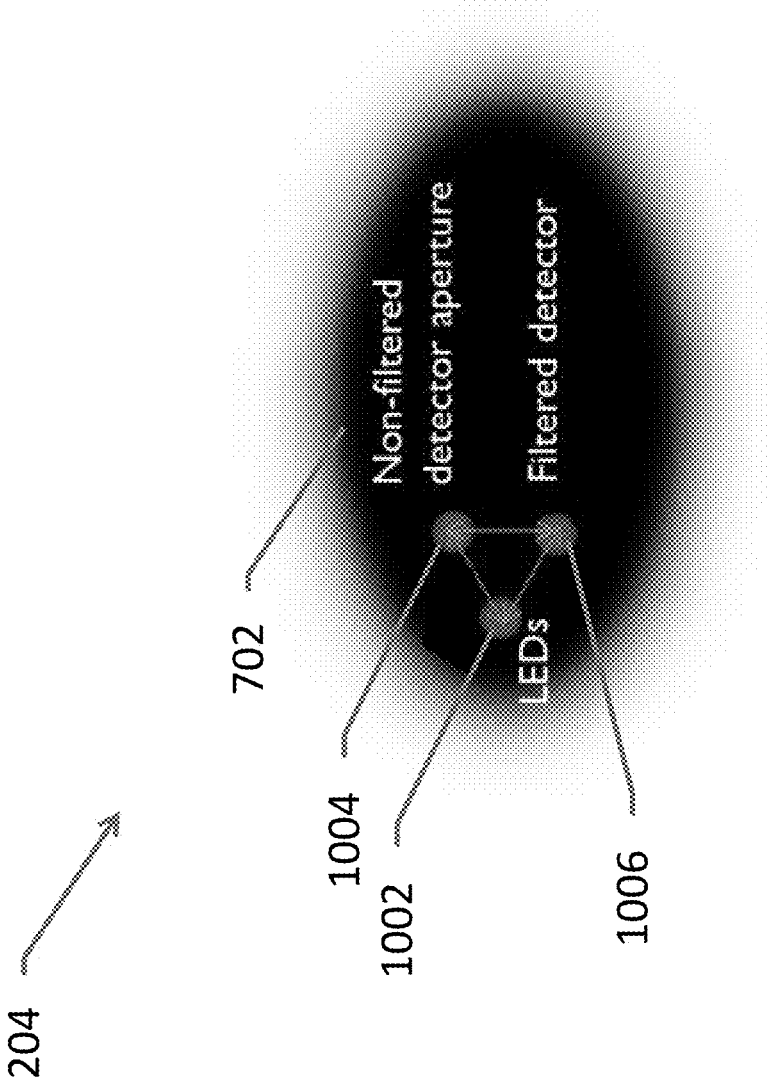

FIG. 10

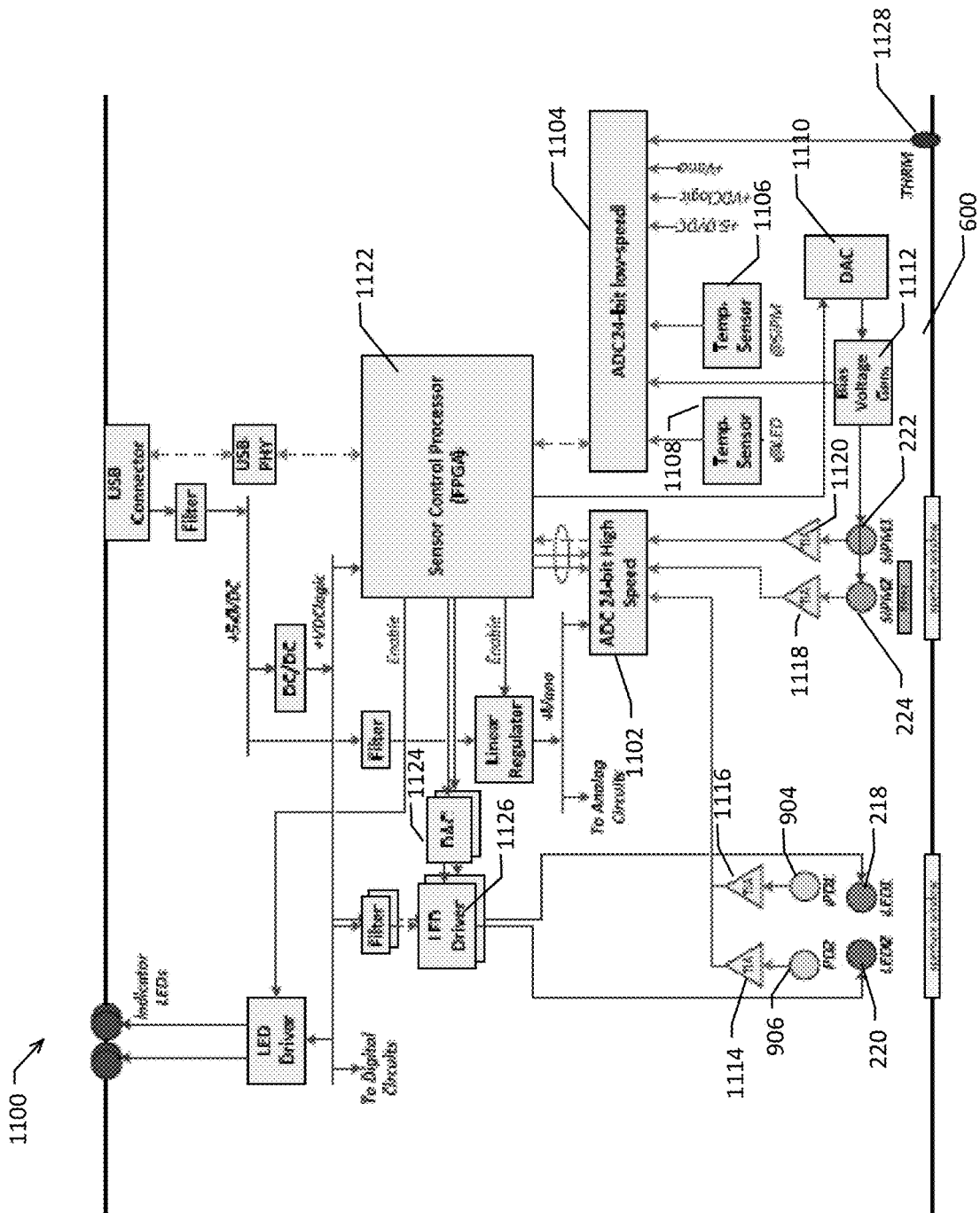

FIG. 11

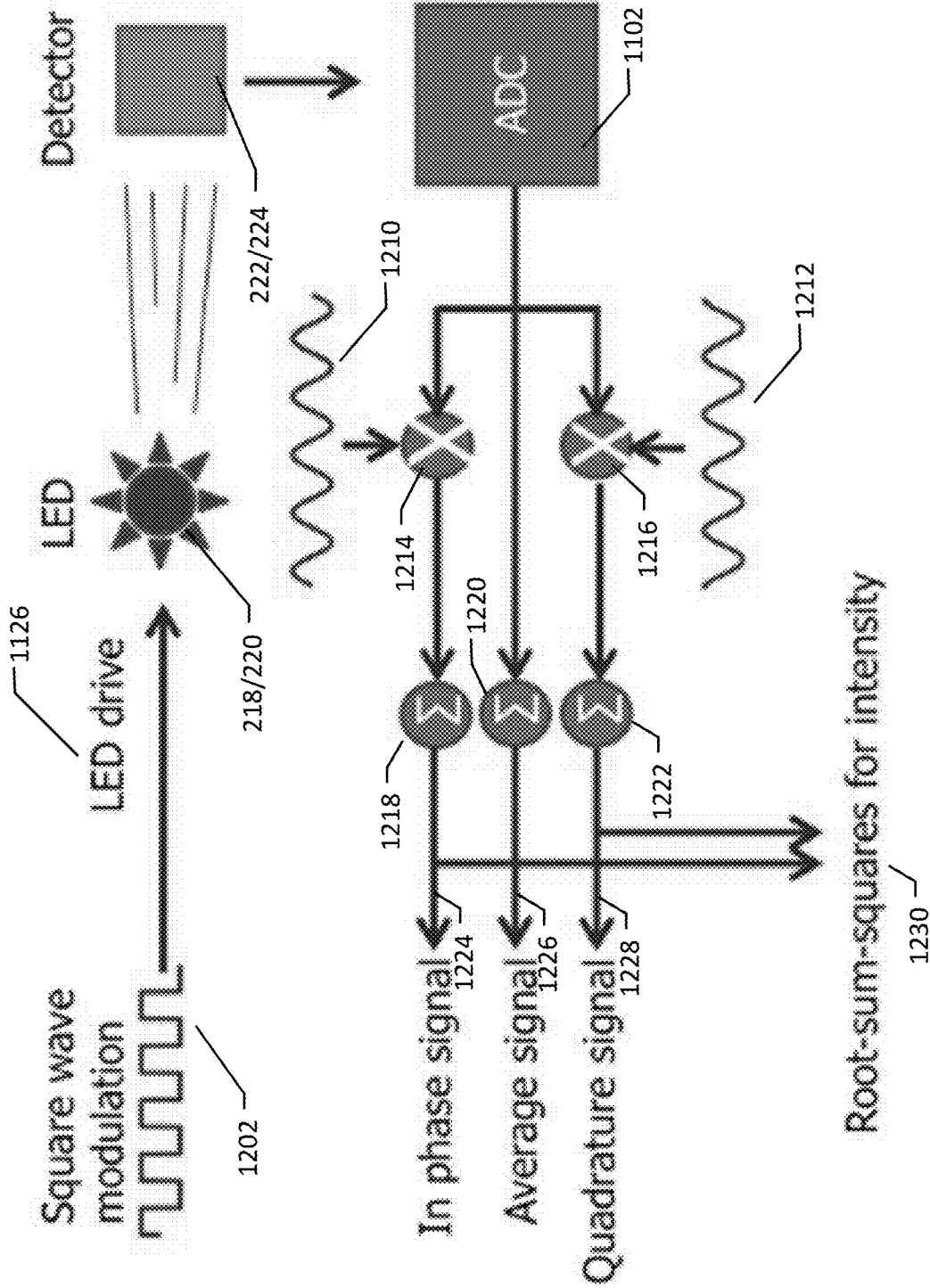
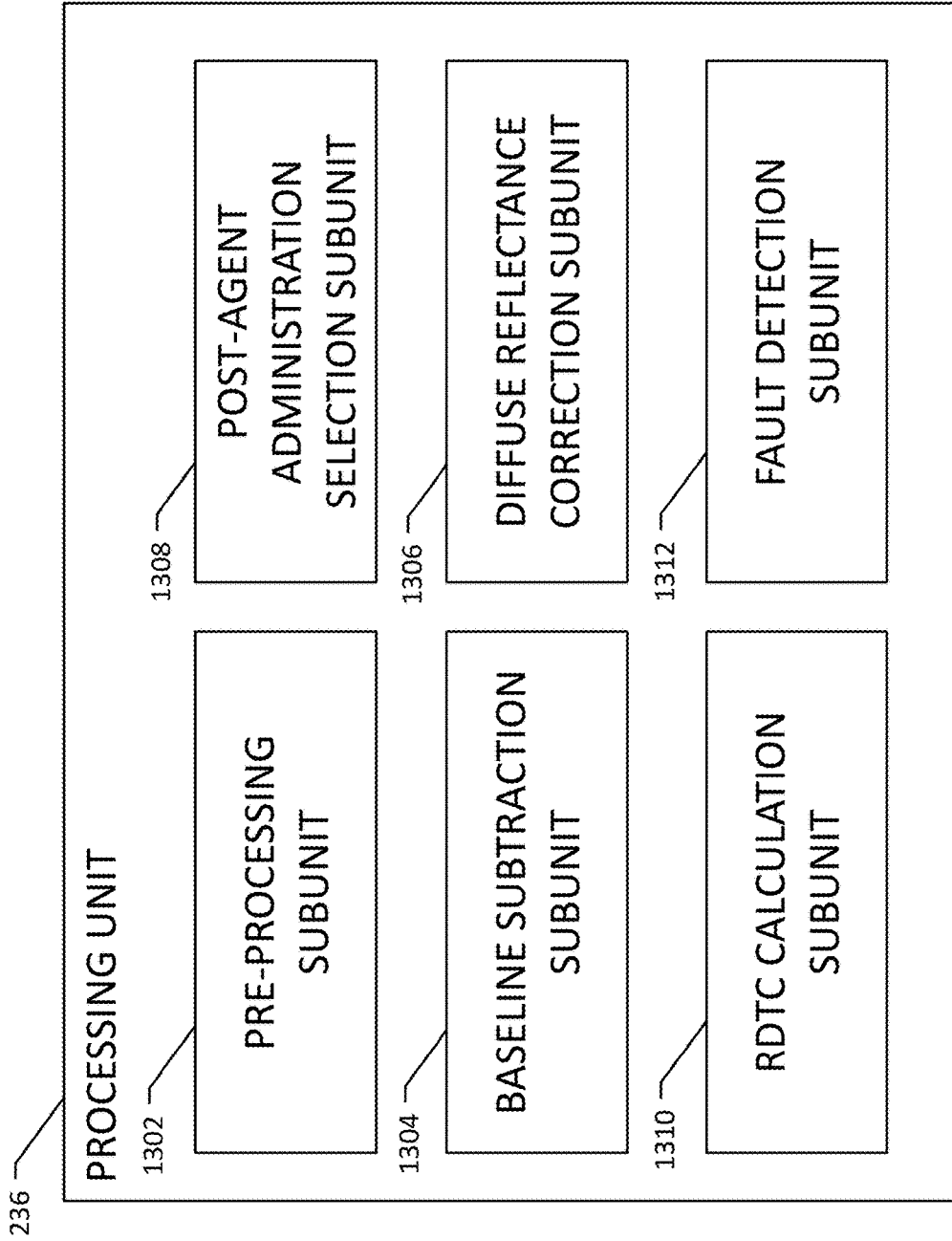

FIG. 12



**FIG. 13**

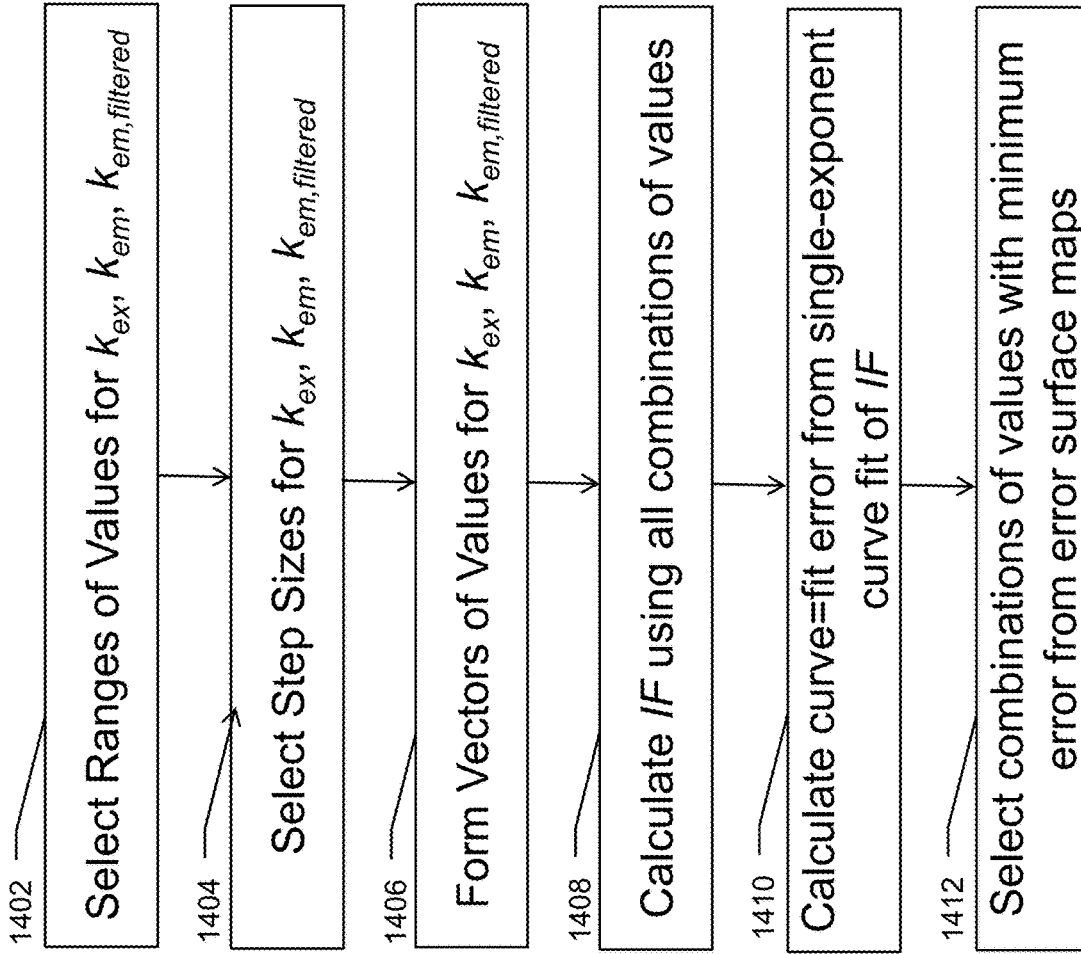
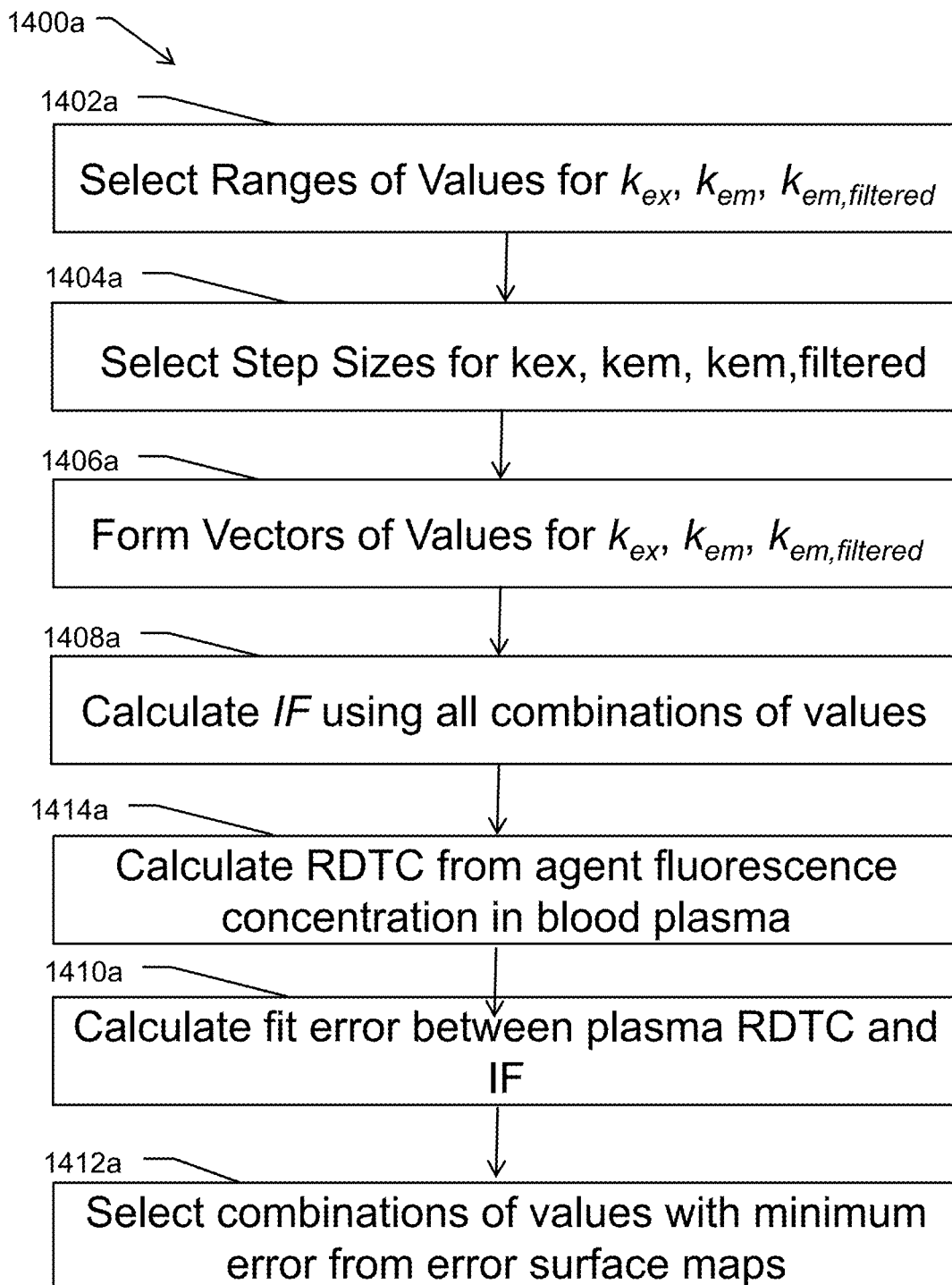

FIG. 14A



**FIG. 14B**



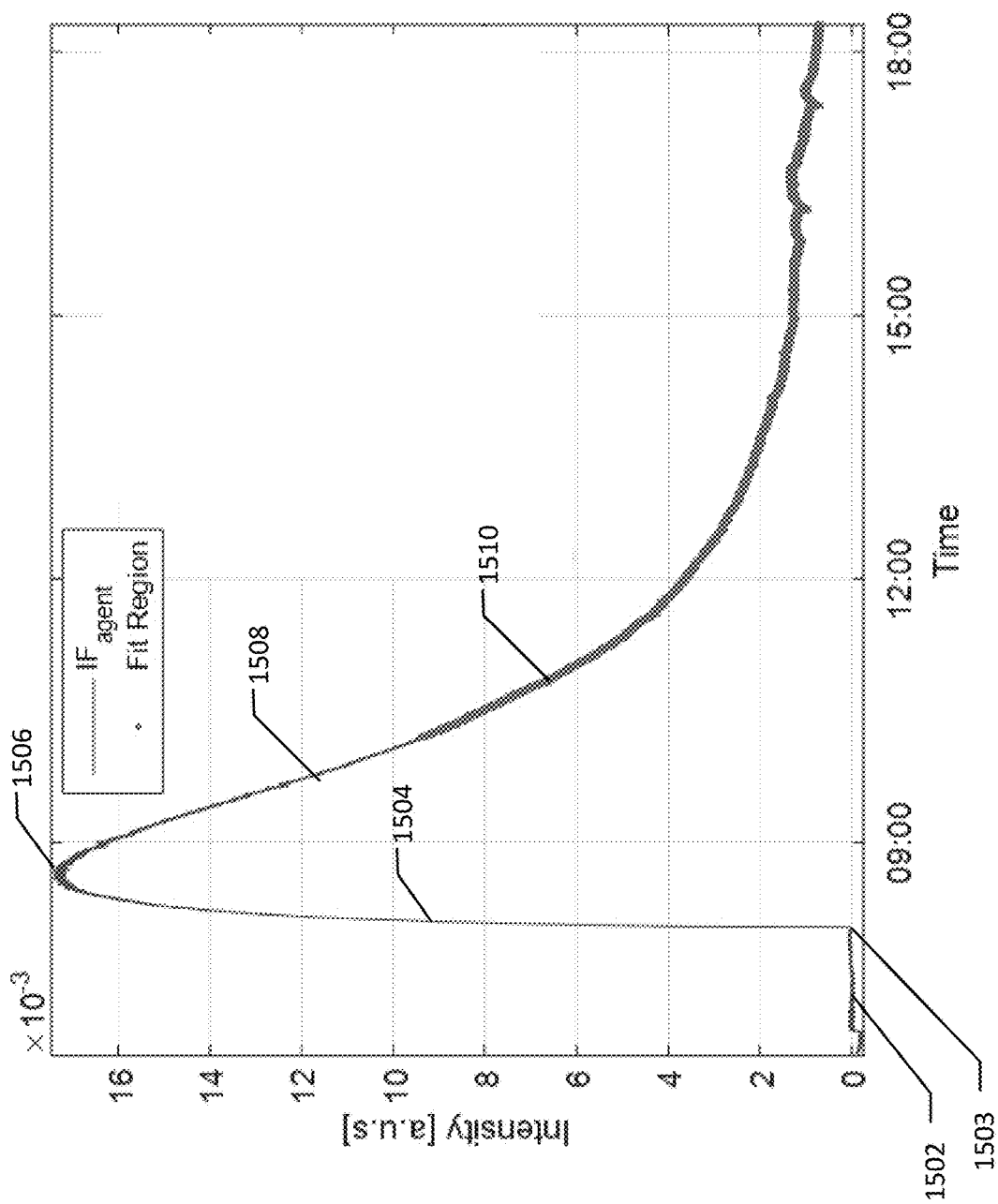

FIG. 15A

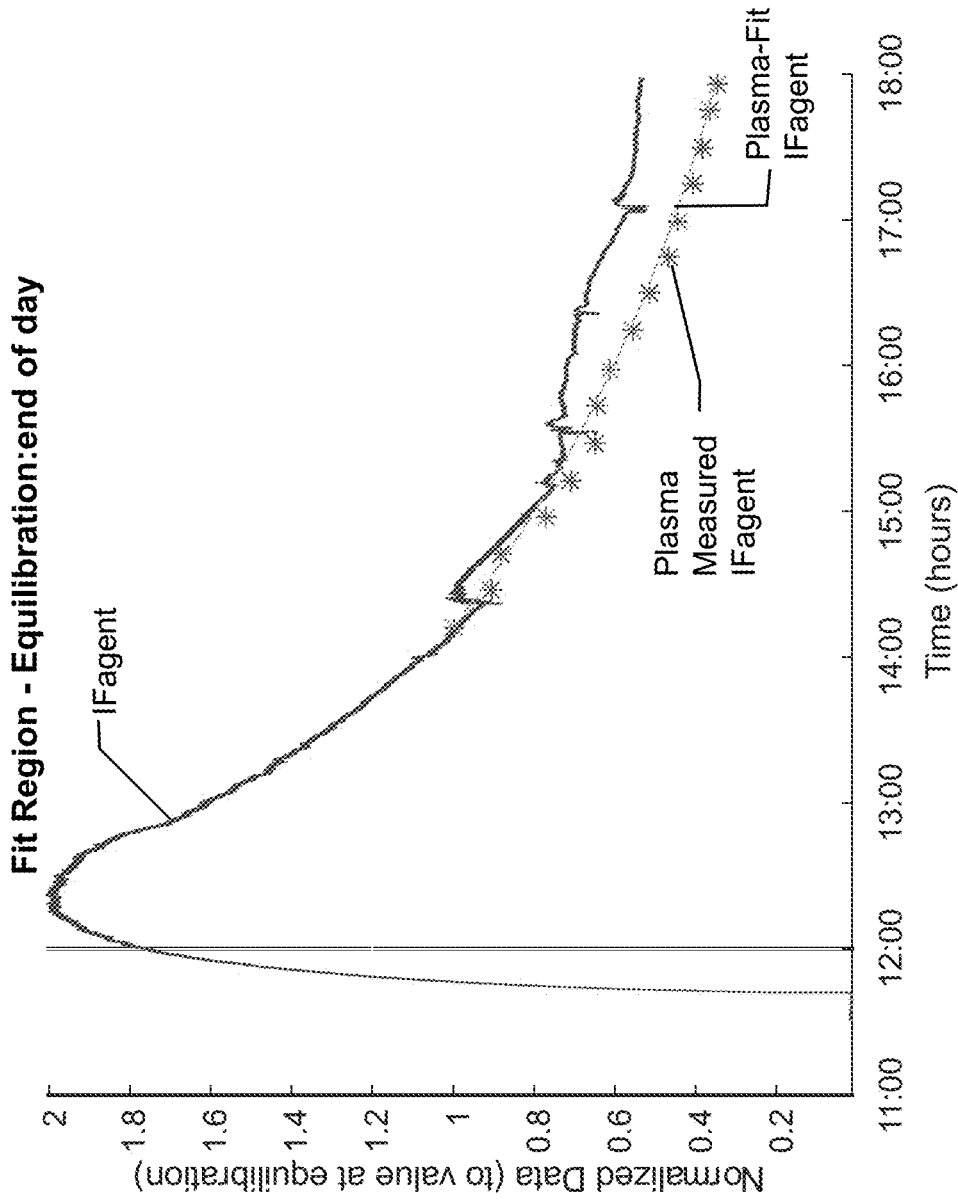

FIG. 15B

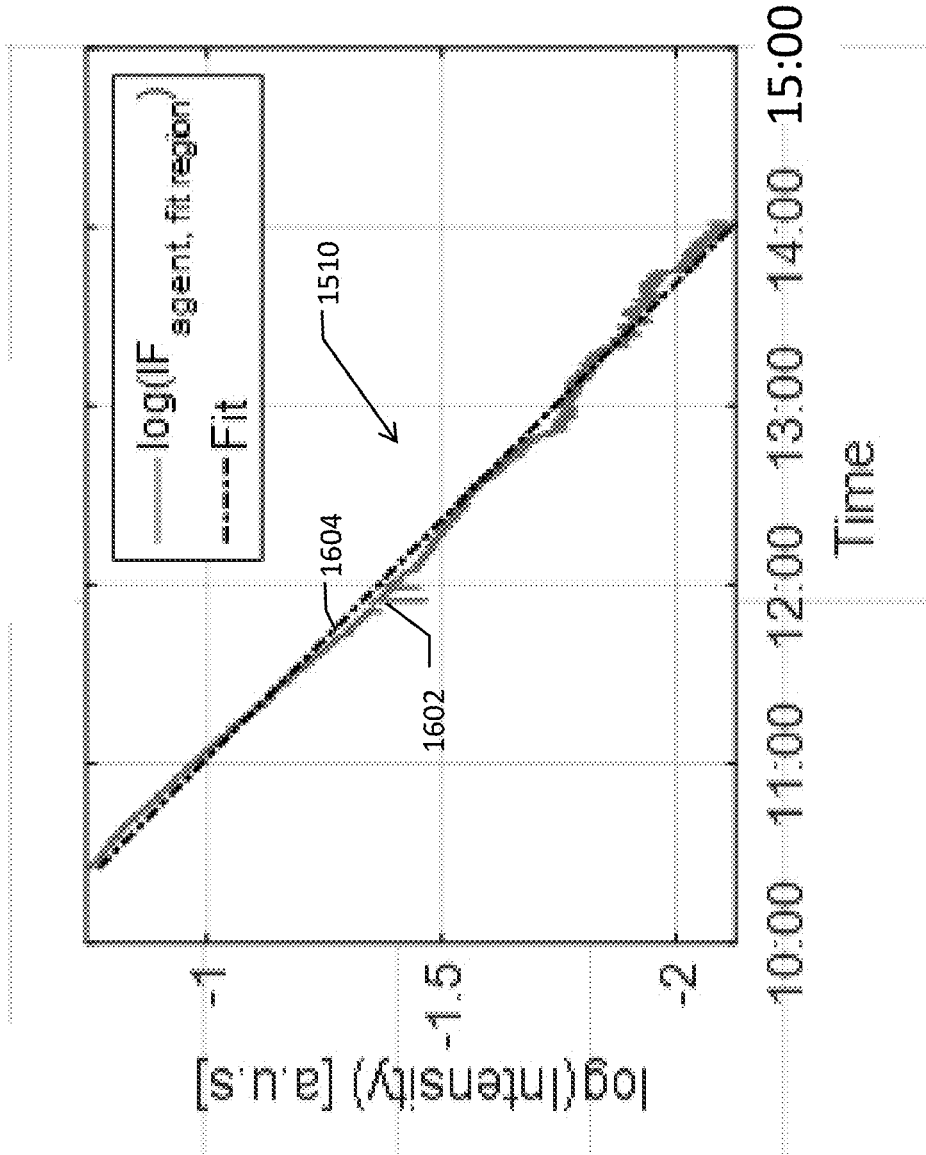
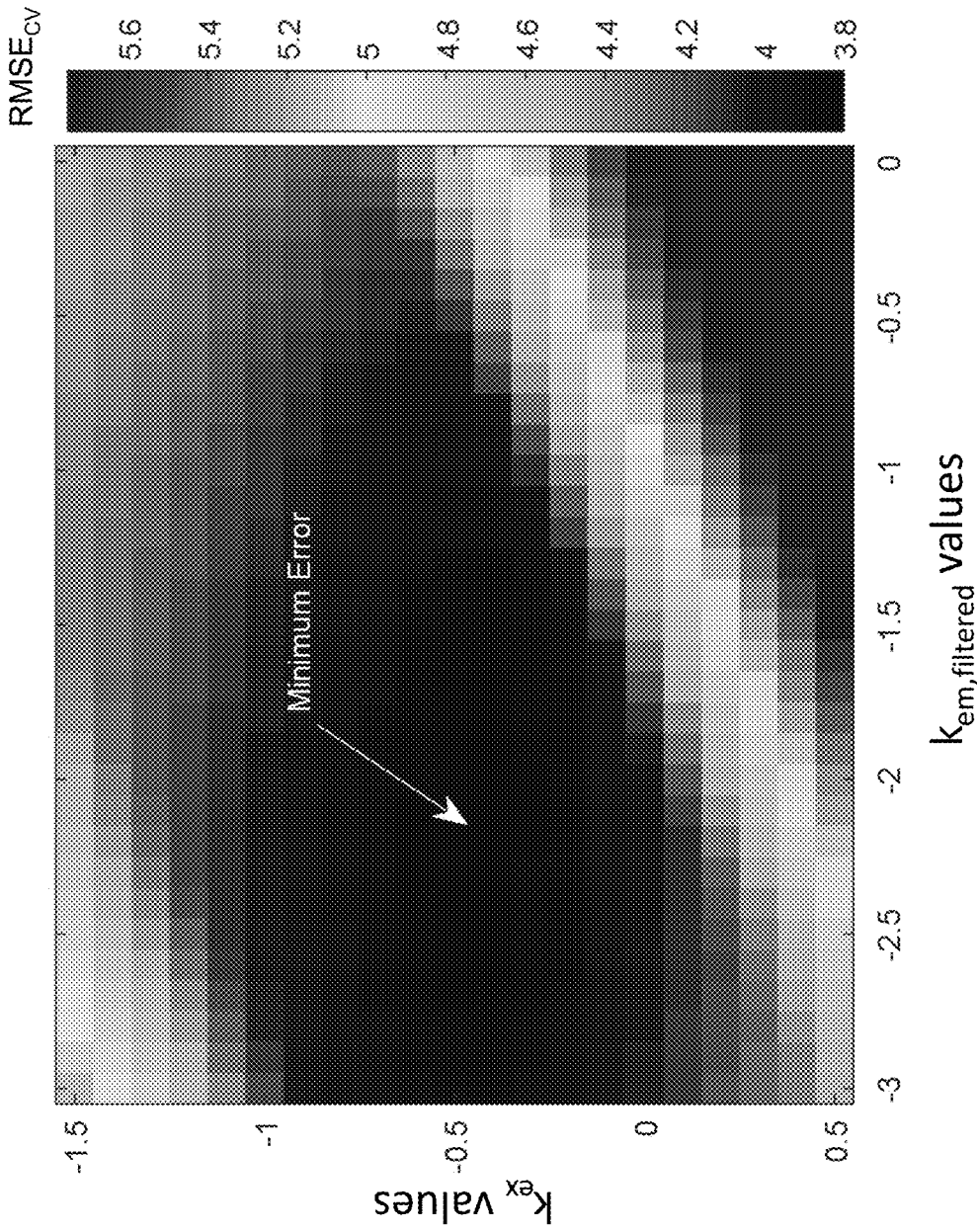

FIG. 16



**FIG. 17**

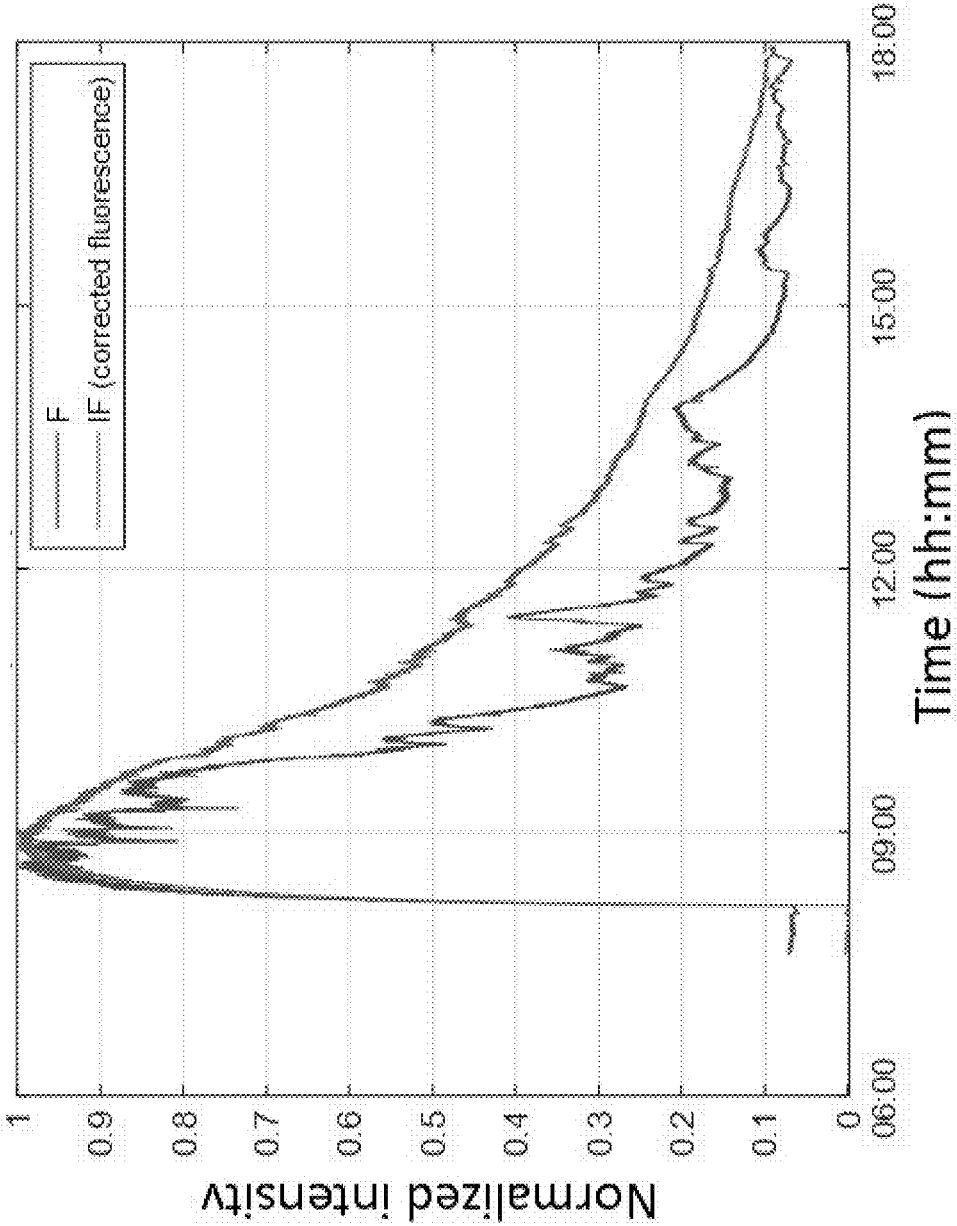

FIG. 18

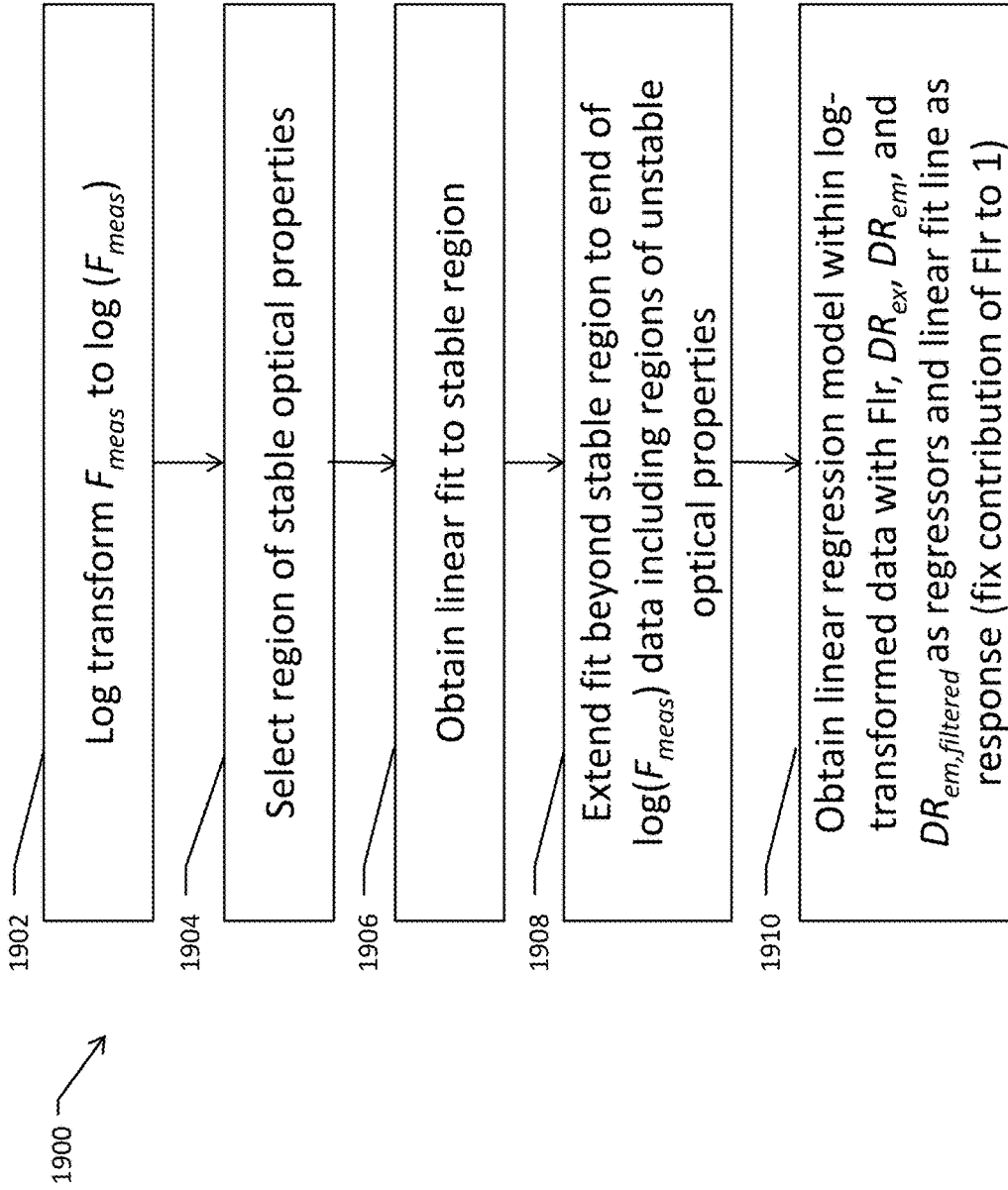

FIG. 19

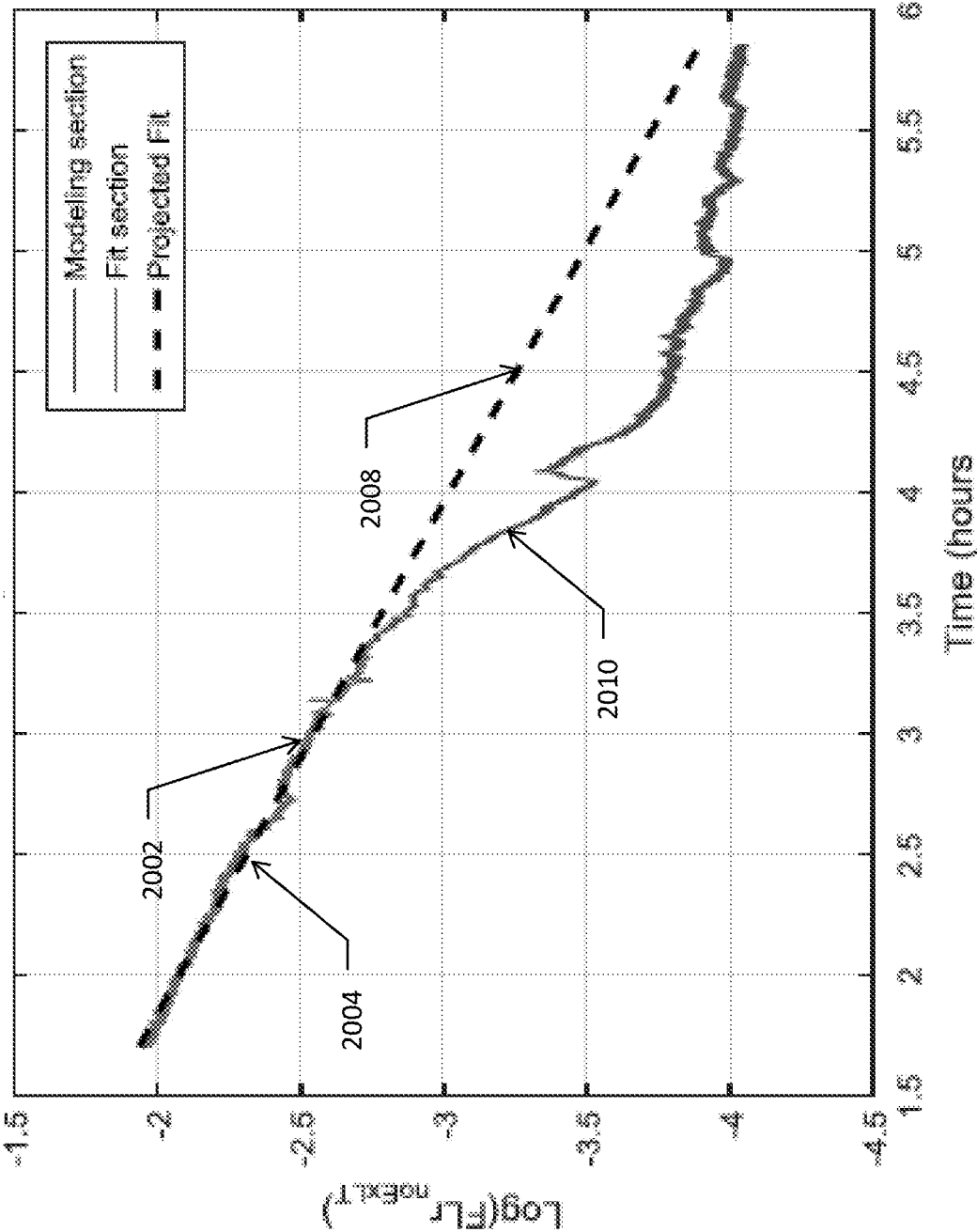

FIG. 20

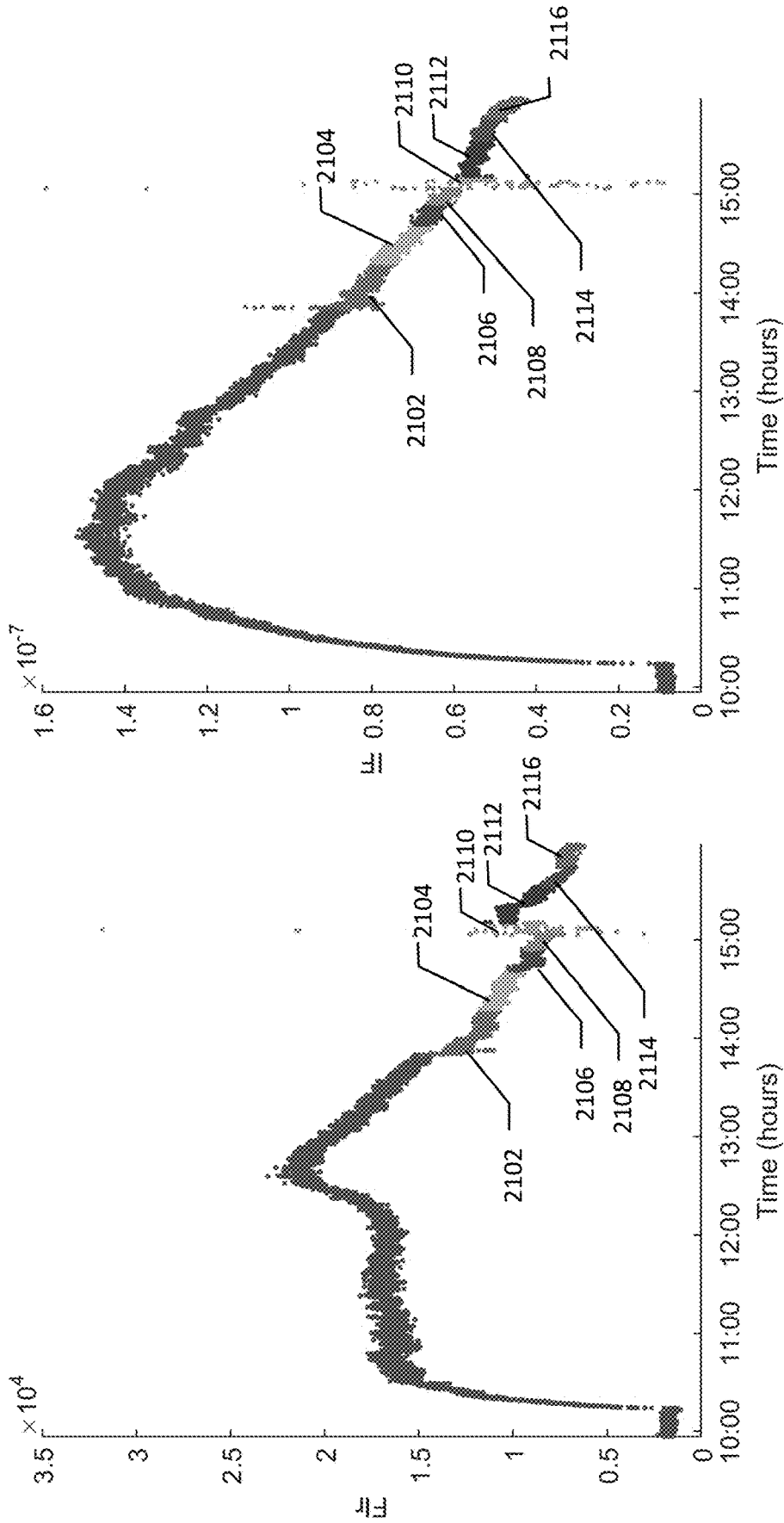

FIG. 21B

FIG. 21A



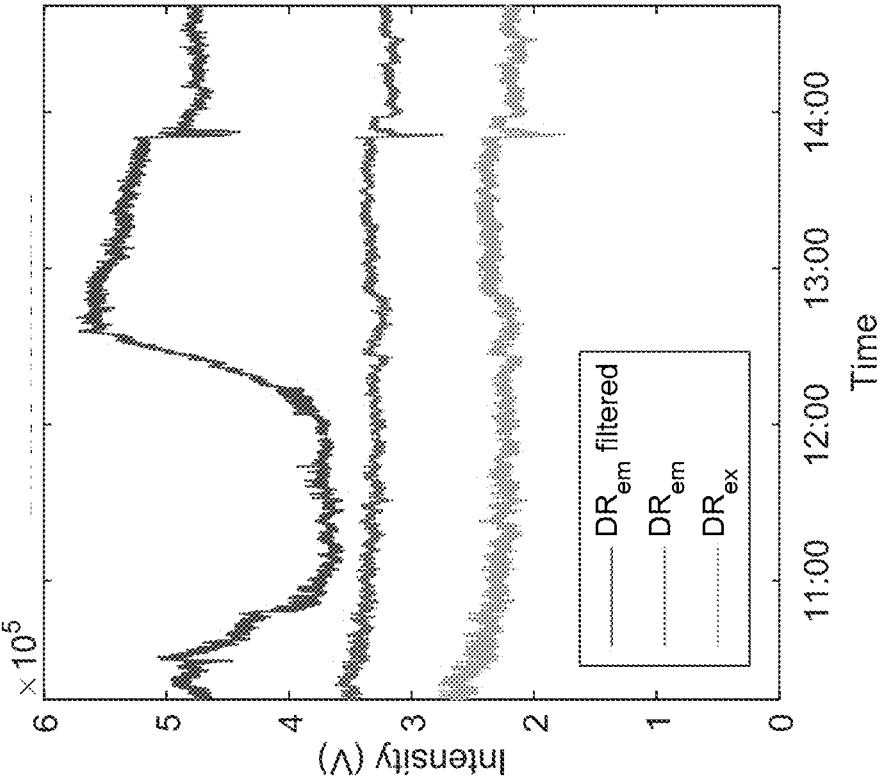

FIG. 21C

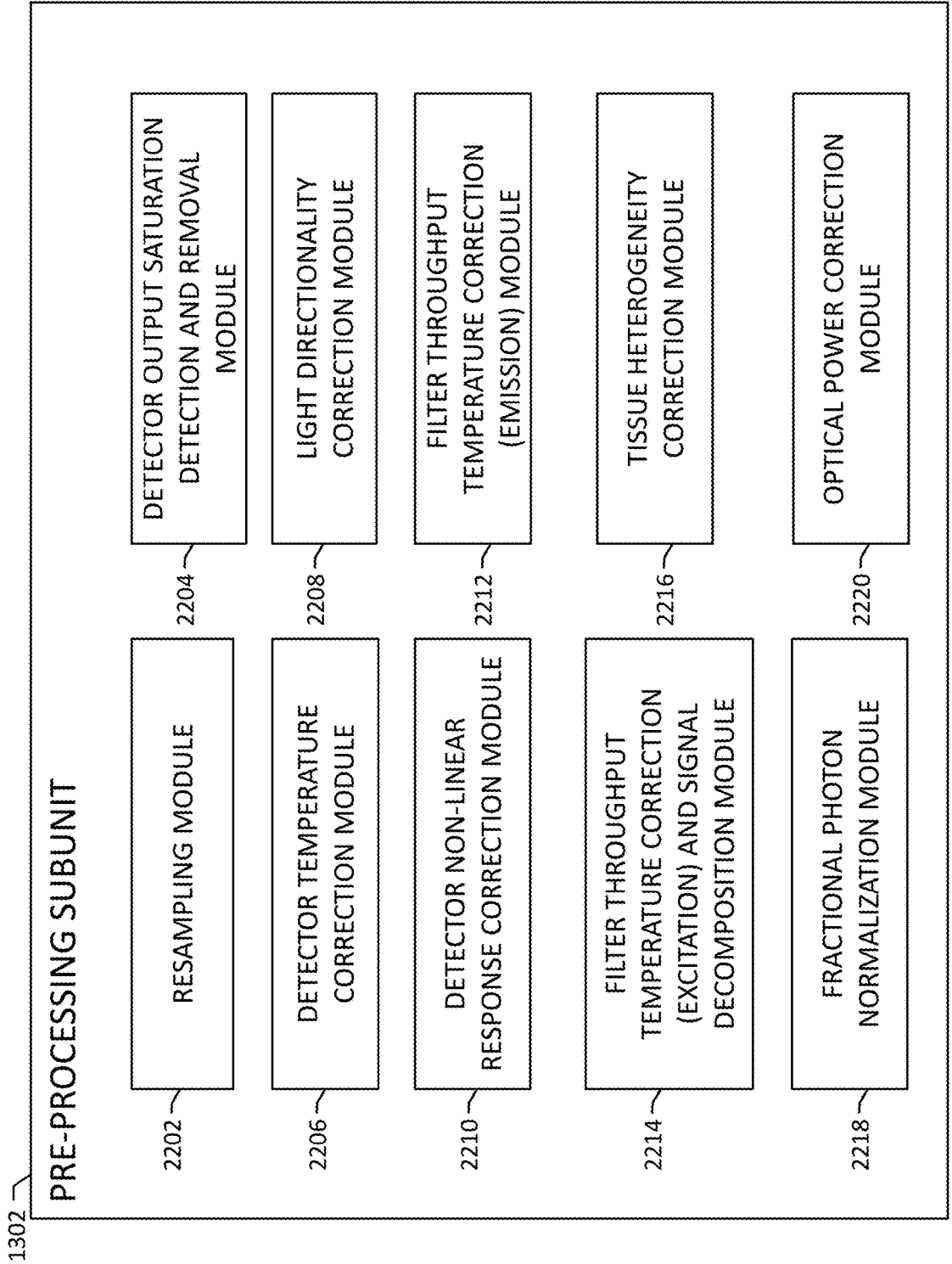

FIG. 22A

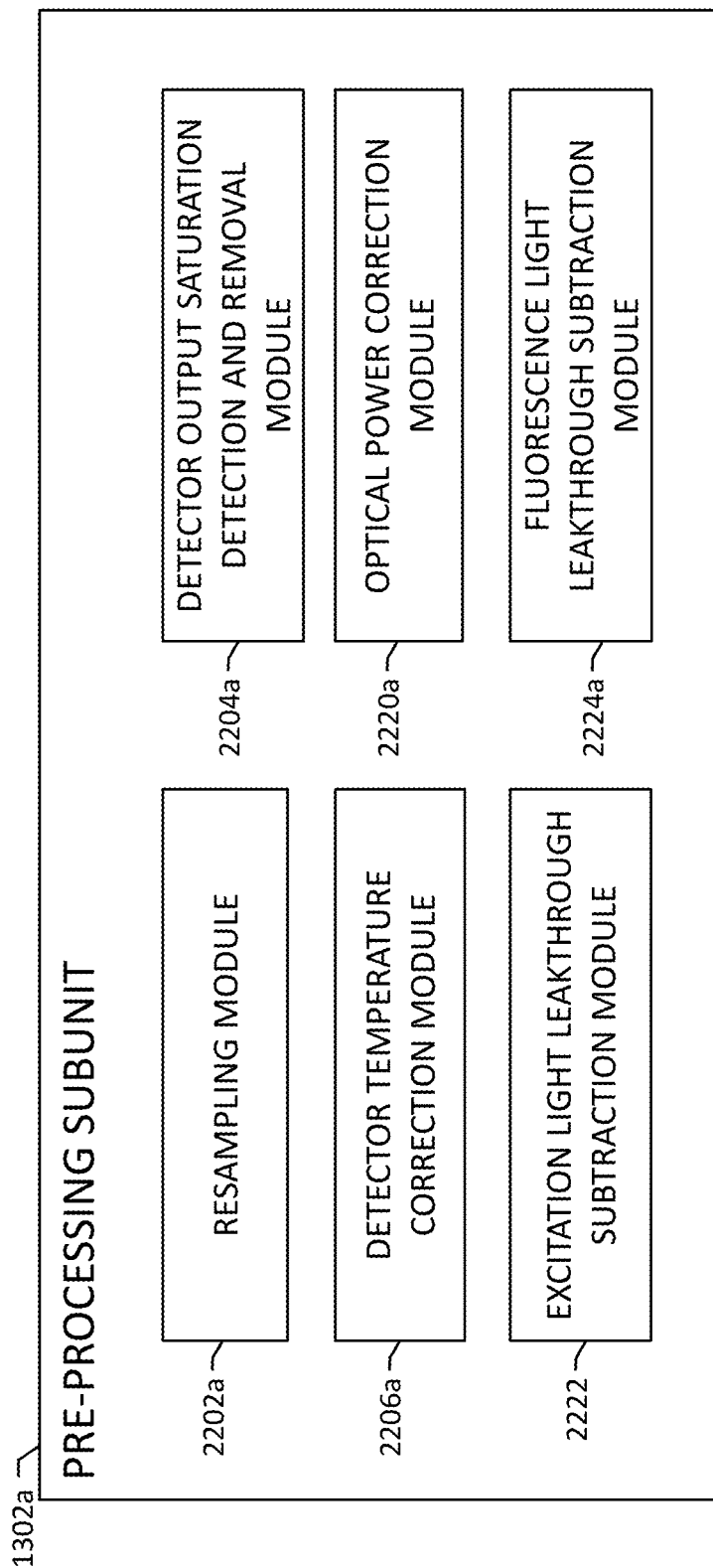

FIG. 22B

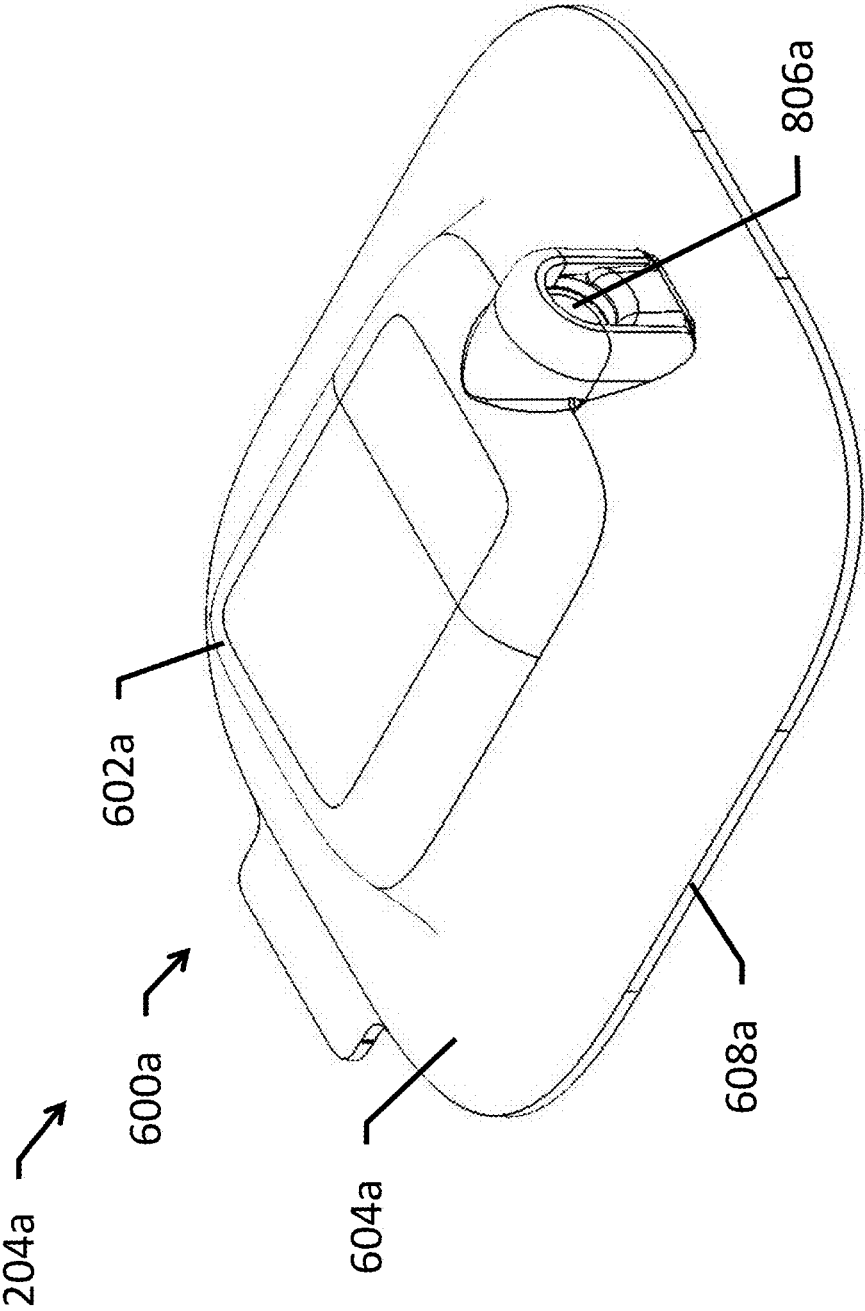

FIG. 23

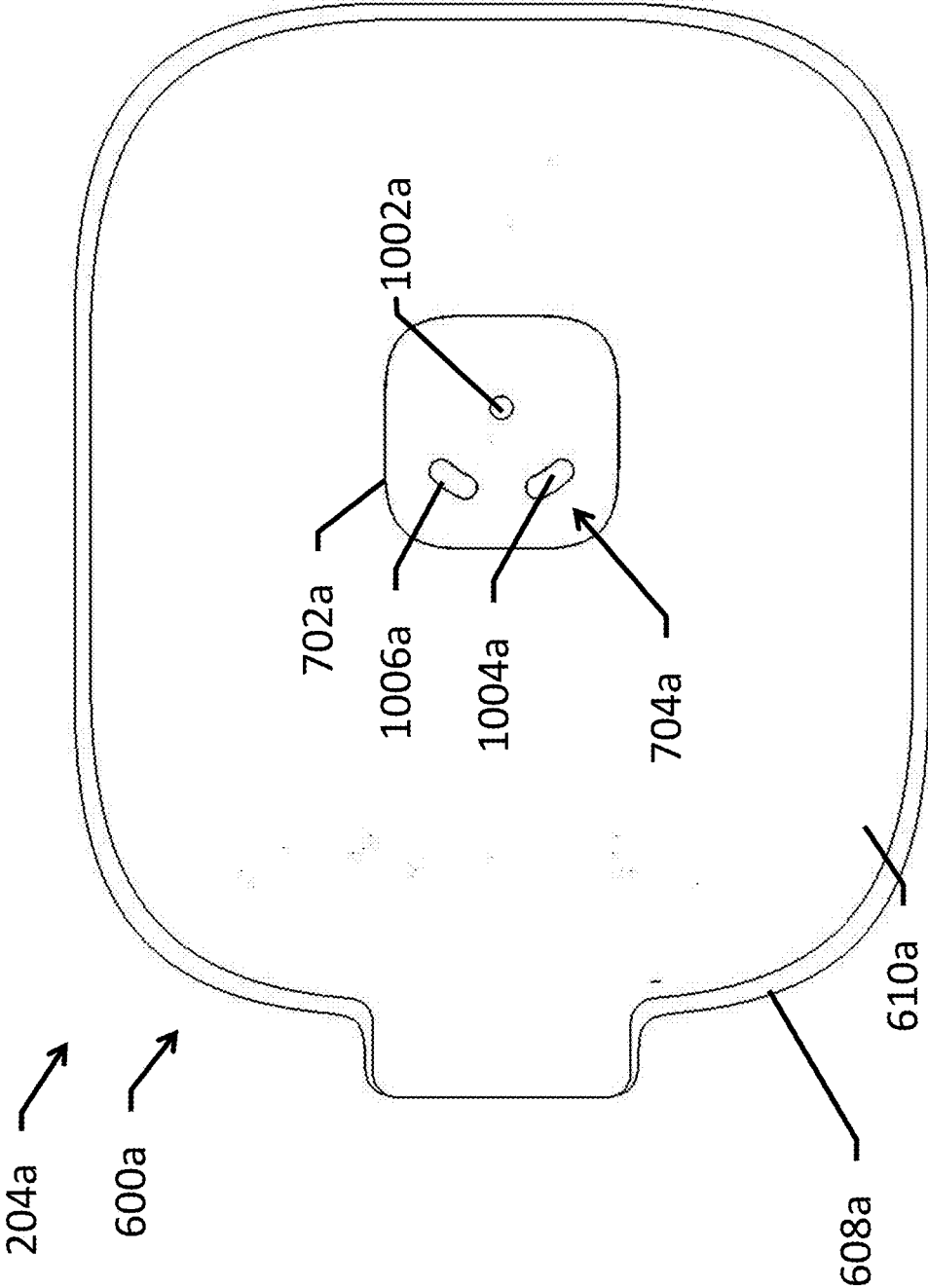

FIG. 24

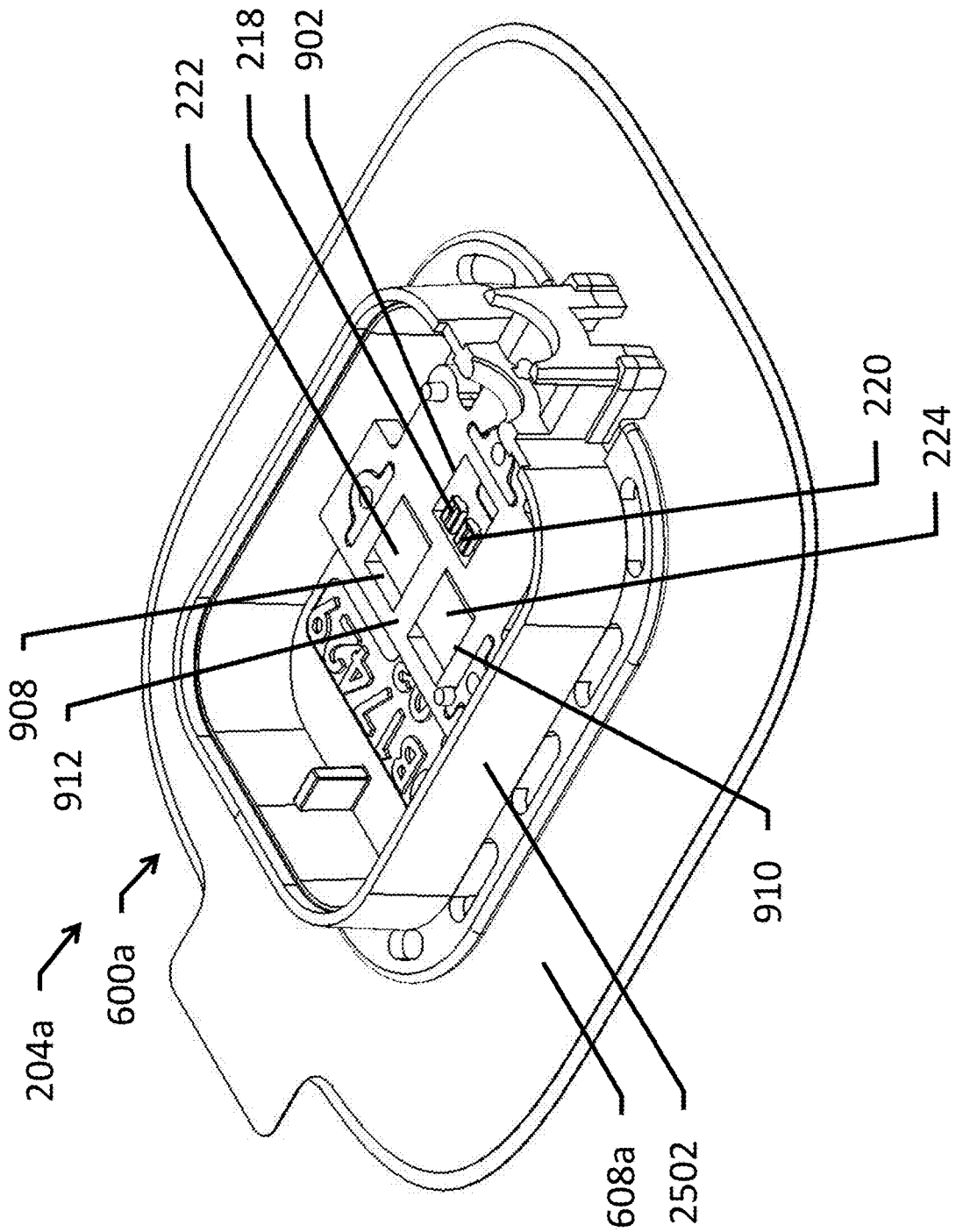
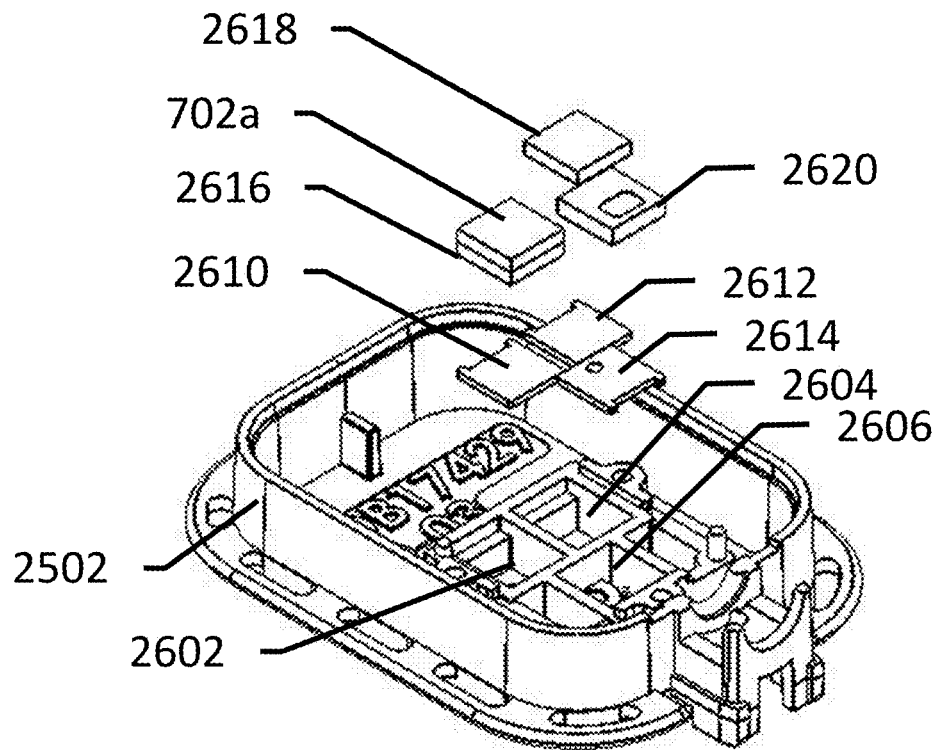
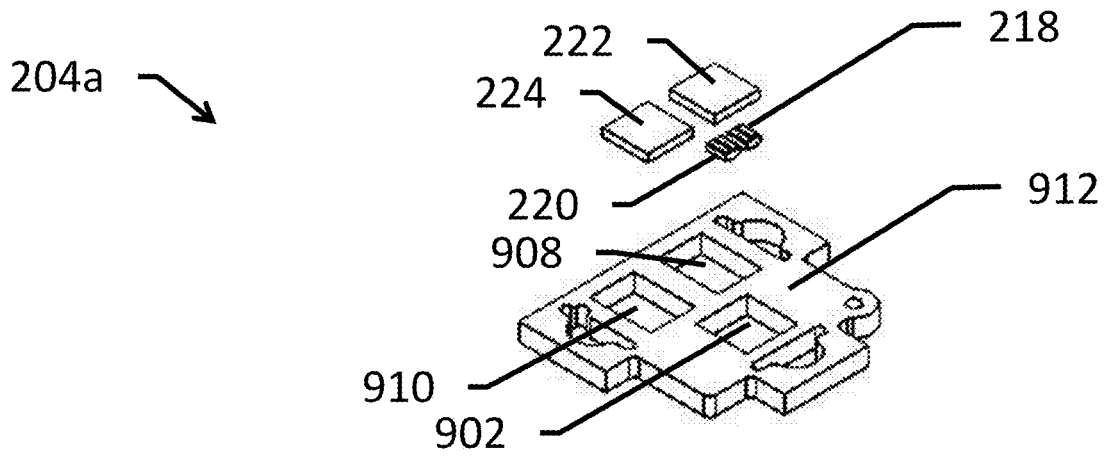

FIG. 25



**FIG. 26**

**METHOD FOR NON-INVASIVE  
MONITORING OF FLUORESCENT TRACER  
AGENT WITH DIFFUSE REFLECTING  
MEDIUM WITH TIME-VARYING OPTICAL  
PROPERTIES**

**CROSS-REFERENCE TO RELATED  
APPLICATIONS**

**[0001]** This application is a continuation of U.S. application Ser. No. 17/932,713, filed Sep. 16, 2022, which is a continuation of U.S. application Ser. No. 17/200,381, filed Mar. 12, 2021, which is a continuation of U.S. application Ser. No. 16/717,436, filed Dec. 17, 2019 and which issued as U.S. Pat. No. 10,980,459, which is a continuation of U.S. application Ser. No. 15/884,365, filed Jan. 30, 2018 and which issued as U.S. Pat. No. 10,548,521, which claims the benefit of U.S. Provisional Application No. 62/452,025 filed Jan. 30, 2017, the entire contents of which are hereby incorporated by reference in their entirety.

**BACKGROUND OF THE DISCLOSURE**

**[0002]** The present disclosure relates generally to methods for non-invasive monitoring of a fluorescent tracer agent within a medium characterized by scattering and/or absorption of light. More particularly, the present disclosure relates to methods for non-invasive assessment of kidney function by monitoring the clearance of an exogenous fluorescent tracer within the tissues of a patient in vivo.

**[0003]** Dynamic monitoring of renal function in patients at the bedside in real time is highly desirable in order to minimize the risk of acute renal failure brought on by various clinical, physiological and pathological conditions. It is particularly important in the case of critically ill or injured patients because a large percentage of these patients face the risk of multiple organ failure (MOF) incited by one or more severe dysfunctions, such as: acute lung injury (ALI), adult respiratory distress syndrome (ARDS), hypermetabolism, hypotension, persistent inflammation, and/or sepsis. Renal function may also be impaired due to kidney damage associated with administration of nephrotoxic drugs as part of a procedure such as angiography, diabetes, autoimmune disease, and other dysfunctions and/or insults causally linked to kidney damage. In order to assess a patient's status and to monitor the severity and/or progression of renal function over extended periods, there exists considerable interest in developing a simple, accurate, and continuous method for the determination of renal failure, preferably by non-invasive procedures.

**[0004]** Serum creatinine concentration, an endogenous marker of renal function, is typically measured from a blood sample and used, in combination with patient demographic factors such as weight, age, and/or ethnicity to estimate glomerular filtration rate (GFR), one measure of renal function. However, creatinine-based assessments of renal function may be prone to inaccuracies due to many potential factors, including: age, state of hydration, renal perfusion, muscle mass, dietary intake, and many other anthropometric and clinical variables. To compensate for these variances, a series of creatinine-based equations (most recently extended to cystatin C) have been developed which incorporate factors such as sex, race and other relevant factors for the estimation of glomerular filtration rate (eGFR) based on serum creatinine measurements. However, these eGFR

equations are not provided with any means of compensating for most of the above sources of variance, and therefore have relatively poor accuracy. Further, the eGFR method typically yields results that lag behind true GFR by up to 72 hrs. **[0005]** Exogenous marker compounds, such as inulin, iothalamate, <sup>51</sup>Cr-EDTA, Gd-DTPA and <sup>99m</sup>Tc-DTPA have been used in existing methods for measuring GFR. Other endogenous markers, such as <sup>123</sup>I and <sup>125</sup>I labeled o-iodohippurate or <sup>99m</sup>Tc-MAG3 have been used to in other existing methods for assessing the tubular secretion process. However, the use of typical exogenous marker compounds may be accompanied by various undesirable effects including the introduction of radioactive materials and/or ionizing radiation into the patient, and laborious ex vivo handling of blood and urine samples, rendering existing methods using these exogenous markers unsuitable for real-time monitoring of renal function at a patient's bedside.

**[0006]** The availability of a real-time, accurate, repeatable measure of renal excretion rate using exogenous markers under patient-specific yet potentially changing circumstances would represent a substantial improvement over any currently practiced method. Moreover, a method that depends solely on the renal elimination of an exogenous chemical entity would provide a direct and continuous pharmacokinetic measurement requiring less subjective interpretation based upon age, muscle mass, blood pressure, etc.

**SUMMARY OF THE DISCLOSURE**

**[0007]** In some aspects, a method of assessment of renal function by monitoring a time-varying fluorescence signal emitted from a fluorescent agent from within a diffuse reflecting medium with time-varying optical properties is provided. The method comprises: using a renal monitoring system comprising at least one light source, at least one light detector, at least one optical filter, and at least one controller to provide a measurement data set comprising a plurality of measurement entries, each measurement data entry comprising at least two measurements obtained at one data acquisition time from a patient before and after administration of the fluorescent agent, the at least two measurements selected from: a DR<sub>ex</sub> signal detected at a second region adjacent to the diffuse reflecting medium by an unfiltered light detector during illumination of the diffuse reflecting medium by excitatory-wavelength light from a first region adjacent to the diffuse reflecting medium; an Flr signal detected at a third region adjacent to the diffuse reflecting medium by a filtered light detector during illumination of the diffuse reflecting medium by excitatory-wavelength light from the first region; a DR<sub>em</sub> signal detected at the second region by the unfiltered light detector during illumination of the diffuse reflecting medium by emission-wavelength light from the first region; and a DR<sub>em,filtered</sub> signal detected at the third region by the filtered light detector during illumination of the diffuse reflecting medium by emission-wavelength light from the first region, identifying a post-agent administration portion of the measurement data set; and transforming each Flr signal of each measurement data entry within the post-agent administration portion of the measurement data set to an IF signal representing a detected fluorescence intensity emitted solely by the fluorescent agent from within the diffuse reflecting medium, wherein transforming comprises combining the at least two measurements according to a transformation relation comprising a mathematical equation



converting Flr to IF, wherein the at least two measurements comprise the Flr signal and the  $DR_{em,filtered}$  signal, wherein rate of the decrease in intensity of the IF signal is representative of clearance of the fluorescent agent by kidneys, wherein the transformation relation consists of Eqn. (20):

$$IF = \frac{Flr}{DR_{ex}^{k_{ex}} DR_{em}^{k_{em}} DR_{em,filtered}^{k_{em,filtered}}}; \quad \text{Eqn. (20)}$$

wherein at least one of  $k_{ex}$ ,  $k_{em}$ , and  $k_{em,filtered}$  are periodically evaluated and updated, as necessary to compensate for variations in the design of the renal monitoring system, variation in optical properties across patients, or time-varying optical properties within a given patient over the course of the assessment of renal function.

#### BRIEF DESCRIPTION OF THE DRAWINGS

[0008] The patent or application file contains at least one drawing executed in color. Copies of this patent or patent application publication with color drawing(s) will be provided by the Office upon request and payment of the necessary fee.

[0009] The disclosure will be better understood, and features, aspects and advantages other than those set forth above will become apparent when consideration is given to the following detailed description thereof. Such detailed description makes reference to the following drawings, wherein:

[0010] FIG. 1 is a schematic illustration of a single-wavelength renal monitoring device in one aspect;

[0011] FIG. 2 is a schematic illustration of a dual-wavelength renal monitoring system in one aspect;

[0012] FIG. 3 is a graph summarizing the absorption, transmission, and emission spectra of various devices, materials, and compounds associated with the non-invasive monitoring of an exogenous fluorescent agent in vivo defined over light wavelengths ranging from about 430 nm to about 650 nm;

[0013] FIG. 4 is a graph summarizing the absorption spectra of oxyhemoglobin ( $HbO_2$ ) and deoxyhemoglobin (Hb) defined over light wavelengths ranging from about 200 nm to about 650 nm;

[0014] FIG. 5 is a schematic illustration of the timing of light pulse cycles associated with data acquisition by a dual-wavelength renal monitoring system in one aspect, in which each light pulse cycle includes light pulses produced at the excitation wavelength and at the emission wavelength in sequence;

[0015] FIG. 6 is a side view of a sensor head of a renal function monitoring system in one aspect;

[0016] FIG. 7 is a bottom view of the sensor head of FIG. 6;

[0017] FIG. 8 is a top interior view of the sensor head of FIG. 6 illustrating an arrangement of various electrical components within a housing of a sensor head of a renal function monitoring system in one aspect;

[0018] FIG. 9 is an enlargement of the interior view of FIG. 8;

[0019] FIG. 10 is a schematic illustration of the apertures formed within a contact surface of a sensor head of a renal function monitoring system in one aspect;

[0020] FIG. 11 is a schematic illustration of synchronous detection of light by a light detector of a sensor head in one aspect;

[0021] FIG. 12 is a schematic illustration of light signal modulation and demodulation by the sensor head in one aspect;

[0022] FIG. 13 is a block diagram illustrating the subunits of a processing unit in one aspect;

[0023] FIG. 14A is a flow chart illustrating the steps of a global error mapping method of determining the parameters of a diffuse reflectance correction equation in one aspect;

[0024] FIG. 14B is a flow chart illustrating the steps of a global error mapping method of determining the parameters of a diffuse reflectance correction equation in a second aspect;

[0025] FIG. 15A is a graph of representative intrinsic fluorescence measurements of the fluorescent agent ( $IF_{agent}$ ) detected by a renal monitoring device obtained before and after injection of an exogenous fluorescent agent. A subset of the data selected for analysis to determine correction factors are shown highlighted in orange.

[0026] FIG. 15B is a graph of representative intrinsic fluorescence measurements of the fluorescent agent ( $IF_{agent}$ ) detected by a renal monitoring device obtained before and after injection of an exogenous fluorescent agent. A subset of the data selected for analysis by fitting the  $IF_{agent}$  to a plasma-derived  $IF_{agent}$  to determine correction factors are shown highlighted in orange.

[0027] FIG. 16 is a graph comparing the log-transformed single-exponential curve fit of the corrected fluorescence signal measurements ( $\log[Fit]$ , black dashed line) and the corrected fluorescence signal measurements from FIG. 15 ( $IF_{agent}$ , red line) over a portion of the selected analysis region from FIG. 15.

[0028] FIG. 17 is a map of a representative error surface summarizing normalized root-mean-square errors (RMSE, color scale) calculated for the difference between the linear fit to the log of the fluorescence and the corrected fluorescence signal measurements for a range of correction factors  $k_{ex}$  and  $k_{em,filtered}$  with a minimum RSME region identified by a white arrow overlaid on the map;

[0029] FIG. 18 is a graph comparing raw (F, blue line) fluorescence signal measurements and corrected (IF, red line) fluorescence signal measurements obtained before and after injection of an exogenous fluorescent agent.

[0030] FIG. 19 is a flow chart summarizing the steps of a linear regression model method of determining the parameters of a diffuse reflectance correction equation in one aspect;

[0031] FIG. 20 is a graph of log-transformed raw fluorescence signal ( $\log(Flr)$ ) showing the regions of the data used as project fits for: a linear regression model used to develop a data correction algorithm (orange line), the response variable for the linear regression model (black dashed line), and the region of highly varying data used to train the linear regression model (blue line);

[0032] FIG. 21A is a graph of raw fluorescence signal measurements obtained before and after injection of an exogenous fluorescent agent. Measurements of raw fluorescence signals were obtained during exposure to various perturbations denoted as colored regions starting at about 13:50 hours. The various perturbations included variations in blood oxygenation in the test subject, application and removal of pressure to the measured region, administration

of blood pressure medication to the test subject, cooling of the measured region, and removal/replacement of the sensor head of the device;

[0033] FIG. 21B is a graph of corrected fluorescence signal measurements of FIG. 21A;

[0034] FIG. 21C is a graph of diffuse reflectance signal measurements measured simultaneously with the raw fluorescence signal measurements of FIG. 21A. These signals are used in the correction of the raw fluorescence signal measurements of FIG. 21A to produce the corrected signal shown in FIG. 21B;

[0035] FIG. 22A is a block diagram illustrating a plurality of modules of a pre-processing subunit in one aspect;

[0036] FIG. 22B is a block diagram illustrating a plurality of modules of a pre-processing subunit in a second aspect;

[0037] FIG. 23 is an isometric view of a sensor head of a renal function monitoring system in a second aspect;

[0038] FIG. 24 is a bottom view of the sensor head of a renal function monitoring system illustrated in FIG. 23;

[0039] FIG. 25 is an isometric view of the sensor head of a renal function monitoring system illustrated in FIG. 23 with the upper housing and various electrical components removed to expose an inner housing; and

[0040] FIG. 26 is an exploded view of the inner housing of the sensor head illustrated in FIG. 25.

[0041] This written description uses examples to disclose the invention, including the best mode, and also to enable any person skilled in the art to practice the invention, including making and using any devices or systems and performing any incorporated methods. The patentable scope of the invention is defined by the claims, and may include other examples that occur to those skilled in the art. Such other examples are intended to be within the scope of the claims if they have structural elements that do not differ from the literal language of the claims, or if they include equivalent structural elements with insubstantial differences from the literal languages of the claims.

#### DETAILED DESCRIPTION

[0042] Unless defined otherwise, all technical and scientific terms used herein have the same meaning as commonly understood by one of ordinary skill in the art to which the disclosure belongs. Although any methods and materials similar to or equivalent to those described herein may be used in the practice or testing of the present disclosure, the preferred materials and methods are described below.

[0043] A sample, as used herein, refers to a single, discrete data value acquired from a signal and/or telemetry analog-to-digital converter (ADC) for a single acquisition/telemetry channel.

[0044] A measured value, as used herein, refers to a single, discrete data value created by demodulating or accumulating a sequence of samples from one acquisition channel.

[0045] A measurement, as used herein, refers to a set comprising the Demodulated In-Phase, Demodulated Out-of-Phase, and Averaged measurement values from one acquisition channel.

[0046] A measurement subset, as used herein, refers to a set comprising all measurements for all acquisition channels during a single source LED illumination. For example, all measurements of an acquisition channel may include demodulated in-phase, demodulated out-of-phase, and averaged measurements.

[0047] A measurement set, as used herein, refers to a set comprising one measurement subset for each source LED.

[0048] An acquisition, as used herein, refers to the overall process by which a measurement set is obtained.

[0049] A measurement sequence, as used herein, refers to a sequence of one or more measurement sets.

[0050] A telemetry value, as used herein, refers to a single, discrete data value acquired from a single channel of a telemetry ADC.

[0051] A telemetry set, as used herein, refers to a set comprising one telemetry value from each telemetry channel.

[0052] FIG. 1 is a schematic illustration of a system 100, provided as a non-limiting example, in which fluorescence 102 with an emission wavelength ( $\lambda_{em}$ ) is detected from a region of interest of a patient 104 using a light detector 110 configured to detect only those photons with an emission wavelength ( $\lambda_{em}$ ). In general, the exogenous fluorescent agent 112 produces fluorescence 102 in response to an excitation event including, but not limited to: illumination by light 106 at an excitation wavelength ( $\lambda_{ex}$ ), occurrence of an enzymatic reaction, changes in local electrical potential, and any other known excitation event associated with exogenous fluorescent agents. In an aspect, the system 100 may include a light source 108 configured to deliver light 106 at an excitation wavelength ( $\lambda_{ex}$ ) to the patient 104. In this aspect, the fluorescence 102 is produced in response to illumination by the light 106. In addition, the excitation wavelength ( $\lambda_{ex}$ ) of the light 106 and the emission wavelength ( $\lambda_{em}$ ) of the fluorescence 102 are spectrally distinct (i.e.,  $\lambda_{ex}$  is sufficiently different from  $\lambda_{em}$ ) so that the light detector 110 may be configured to selectively detect only the fluorescence 102 by the inclusion of any known optical wavelength separation device including, but not limited to, an optical filter.

[0053] In some aspects, changes in the fluorescence 102 may be monitored to obtain information regarding a physiological function or status of the patient. By way of non-limiting example, the time-dependent decrease in the fluorescence 102 measured after introduction of the exogenous fluorescent agent 112 into a circulatory vessel of the patient 104 may be analyzed to obtain information regarding renal function of the patient 104. In this non-limiting example, the rate of decrease in fluorescence 102 may be assumed to be proportional to the rate of removal of the exogenous fluorescent agent 112 by the kidneys of the patient 104, thereby providing a measurement of renal function including, but not limited to: renal decay time constant (RDTC) and glomerular filtration rate (GFR).

[0054] Without being limited to any particular theory, the intensity of fluorescence 102 detected by the light detector 110 may be influenced by any one or more of numerous factors including, but not limited to: the intensity or power of the light 106 at hex delivered to the patient 104, the scattering and absorption of the light 106 passing through intervening tissues 114 of the patient 104 between the light source 108 and the exogenous fluorescent agents 112, the concentration of exogenous fluorescent agents 112 illuminated by the light 106, and the scattering and absorption of the fluorescence 102 at  $\lambda_{em}$  passing through intervening tissues 114 of the patient 104 between the exogenous fluorescent agents 112 and the light detector 110.

[0055] Existing methods typically assume that the optical properties within the intervening tissue 114 remain essen-

tially unchanged throughout the period during which measurements are obtained by the system 100. As a result, existing methods typically obtain initial measurements through the intervening tissue 114 of the patient 104 prior to introduction of the exogenous fluorescent agent 112, and these initial measurements are subtracted to correct all subsequent data obtained after introduction of the exogenous fluorescent agent 112. However, during long-term monitoring of the patient 104, changes in the optical properties of the intervening tissue 114 may occur due to changes in at least one characteristic including, but not limited to: optical coupling efficiency of the light detector 110 to the patient 104; concentration of chromophores such as hemoglobin due to changes in blood volume caused by vascular dilation, constriction, or compression; changes in the optical properties of chromophores such as hemoglobin due to changes in oxygenation status; and changes in tissue structure such as changes related to edema.

**[0056]** These dynamic changes in the optical properties of the intervening tissue 114 may introduce uncertainty into long-term measurements of fluorescence 102. By way of non-limiting example, changes in the optical properties of the intervening tissue 114 may modulate the intensity or power of the light 106 illuminating the exogenous fluorescent agents 112, causing a modulation of the fluorescence 102 produced by the exogenous fluorescent agents 112 that may be erroneously interpreted as a modulation in the concentration of the exogenous fluorescent agents 112. By way of another non-limiting example, changes in the optical properties of the intervening tissue 114 may modulate the intensity or power of the fluorescence 102 reaching the light detector 110 that may also be erroneously interpreted as a modulation in the concentration of the exogenous fluorescent agents 112. The potential modulation of changes in the optical properties of the intervening tissue 114 may introduce uncertainty into measurements of fluorescence 102, in particular those measurements associated with long-term monitoring of fluorescence 102 as described herein above.

**[0057]** In various aspects, a method of correcting in vivo real-time measurements of fluorescence from an exogenous fluorescent agent to remove the effects of changes in the optical properties within the tissue of the patient is provided. The inclusion of an additional measurement of light passing through the tissue of the patient via a separate optical pathway (i.e. diffuse reflectance) from the optical pathway of the fluorescence measurements enhanced the quantification of changes in the optical properties of the tissue during prolonged monitoring of fluorescence from an exogenous fluorescent agent within a patient. The inclusion of this additional measurement in the correction method in various aspects was discovered to significantly enhance the fidelity of fluorescence measurements, even in the presence of substantial perturbations as described herein below.

**[0058]** Detailed descriptions of devices for monitoring the fluorescence of an exogenous fluorescent agent in vivo and methods of correcting the fluorescence measurements to remove the effects of the diffuse reflectance of light within the tissue of the patient are provided herein below.

**[0059]** Although the devices and methods are described herein below in the context of a non-invasive optical renal function monitor, it is to be understood that the correction method described herein, with appropriate modification, may be applied to any compatible device configured to perform measurements by delivering EM radiation from an

external source through any scattering medium and/or receiving EM radiation propagated through any scattering medium to an external detector. Non-limiting examples of EM radiation include visible light, near-IR light, IR light, UV radiation, and microwave radiation. The scattering media may include any living or non-living material capable of propagating EM radiation of at least one EM frequency without limitation. At least a portion of the scattering media may further include one or more substructures or compounds capable of reflecting and/or absorbing the EM radiation. Non-limiting examples of scattering media include: a tissue of a living or dead organism, such as a skin of a mammal; a gas such as air with or without additional particles such as dust, fluid droplets, or a solid particulate material; a fluid such as water with or without additional particles such as gas bubbles or a solid particulate material. Further, the devices and methods described herein below are not limited to detection of renal function, but may be modified for use in the detection of the function of other physiological systems including, but not limited to, liver systems, or gastro-intestinal systems.

#### System Description

**[0060]** In various aspects, the methods of correcting fluorescence measurements to remove the effects of variations in local skin properties may be incorporated into any fluorescence monitoring system including, but not limited to, a system for optically monitoring renal function in vivo and in real time by measuring changes in fluorescence of an exogenous fluorescent agent injected into a patient as the agent is renally eliminated from the patient. FIG. 2 is a block diagram of a system 200 for optically monitoring renal function of a patient 202 via measurements of the fluorescence of an injected exogenous fluorescent agent in the patient 202, in one aspect. The system 200 may include at least one sensor head 204 configured to deliver light at an excitatory wavelength ( $\lambda_{exc}$ ) into a first region 206 of the patient 202. The system 200 is further configured to detect light at an emission wavelength ( $\lambda_{em}$ ), at a second region 208 of the patient 202, and to detect light at the excitatory wavelength ( $\lambda_{exc}$ ), and/or emission wavelength ( $\lambda_{em}$ ), at a third region 210 of the patient 202.

**[0061]** The system 200 may further include a controller 212 operatively coupled to the at least one sensor head 204, an operation unit 214, and a display unit 216. In various aspects, the controller 212 is configured to control the operation of the at least one sensor head 204 as described in additional detail herein below. The controller 212 is further configured to receive measurements of light from the at least one sensor head 204. The controller 212 is further configured to correct the light measurements corresponding to fluorescence from exogenous fluorescent agents according to at least one method including, but not limited to, the disclosed methods of correcting fluorescence measurements using measurements of the diffuse reflectance of light. The controller 212 is further configured to transform the fluorescence measurements received from the at least one sensor head 204 into a summary parameter representative of the renal function of the patient 202. In addition, the controller 212 is configured to receive at least one signal representing user inputs from the operation unit 214 and to generate one or more forms for display on the display unit 216 including, but not limited to, a graphical user interface (GUI).

[0062] A detailed description of the sensor head 204 and controller 212 are provided herein below.

#### A. Sensor Head

[0063] In various aspects, the sensor head 204 includes at least one light source and at least one light detector in a housing. FIG. 6 is a side view of a housing 600 for the sensor head 204 in one aspect that includes an upper housing 602 and a lower housing 604 attached together to enclose two light sources and two light detectors. The bottom surface 608 of the lower housing 604 further includes a contact surface 606 configured to be attached to the skin of a patient 202 using a biocompatible adhesive material including, but not limited to, a surgical adhesive. In use, the surface of the adhesive material opposite to the contact surface 606 may be affixed to the skin of the patient 202. In various aspects, the adhesive material may be configured to transmit light through the light sources into the patient and to further transmit the fluorescence from the patient to the light detectors. In one aspect, the adhesive material may be an optically transparent material. In another aspect, the adhesive material may be produced from a non-fluorescing material to prevent the production of confounding fluorescence by the adhesive material.

[0064] In various other aspects, the upper housing 602 may further include one or more openings 806 configured to provide access to the interior for a cable including, but not limited to, a USB cable, and/or to provide a window for a display generated by the circuitry contained within the housing 600, such as an indicator LED.

[0065] FIG. 7 is a bottom view of the housing 600 illustrated in FIG. 8. The contact surface 606 may include an aperture plate 702 including one or more apertures 704 configured to transmit light between the skin of the patient and the light sources and light detectors contained inside the housing 600. In one aspect, the aperture plate 702 may be epoxied into the lower housing 604 to prevent liquid ingress into the interior of the housing 600. In various aspects, the dimensions, arrangement, and/or spacing of the one or more apertures 704 may be selected to enhance various aspects of the operation of the system 200, as described in additional detail herein below. In another aspect, the contact surface 606 may further include a temperature sensor opening 706 configured to provide a thermal path from the skin surface of the patient to an additional temperature sensor 228 configured to monitor the temperature at the skin surface of the patient.

[0066] FIG. 8 is a schematic diagram illustrating the arrangement of the electrical components within the housing 600. Referring to FIG. 8, the upper housing 602 and the lower housing 604 may be affixed together with screws 802, and the screw holes and the interface between the two housing pieces may be filled with a water-resistant filler material 804 including, but not limited to, a silicone material such as room temperature vulcanization silicone (RTV) to inhibit liquid ingress into the interior of the housing 600.

[0067] In an aspect, the housing 600 may further include a cable opening 806 formed through the upper housing 602. The cable opening 806 may be configured to provide access to the interior for an electrical cable including, but not limited to, a USB cable. In one aspect, the cable may enable the supply of power to the light sources, light detectors, indicator lights, and associated electrical devices and circuits as described herein below. In another aspect, the cable

may further enable the communication of control signals into the housing to enable the operation of the electrical components within the housing 600, and the cable may further enable the communication of data signals encoding measurements obtained by one of more of the sensor devices contained within the housing 600 including, but not limited to: the first light detector 222, the second light detector 224, any additional light detectors, such as a first monitor photodiode 904 and a second monitor diode 906, and any additional temperature sensors 228 (see FIG. 9). In an aspect, the cable may be attached to the cable opening 806 and adjacent upper housing 602 with a light absorbent adhesive including, but not limited to, black epoxy and may further be sealed against water incursion using a water resistant filler material including, but not limited to, RTV.

[0068] In an additional aspect, the housing 600 may further include at least one display opening 808 formed through the upper housing 602. In one aspect, each display opening 808 may be configured to provide a window for a display generated by the circuitry contained within the housing 600, such as an indicator LED 810. In an aspect, each indicator LED 810 may be positioned on a circuit board 812. In an aspect, a light pipe 814 may be epoxied into the display opening 808 within the upper housing 602 above each indicator LED 810. Each a light pipe 814 may be filled with a water-resistant filler material such as RTV for liquid ingress protection. In various aspects, the at least one indicator LED 810 may illuminate in a predetermined pattern to enable a user of the system 200 to monitor the operational status of the sensor head 204.

[0069] FIG. 9 is a close-up view of the interior optical region of the sensor head 204 showing the arrangement of the light sources 218/220 and the light detectors 222/224 within the housing 600 in one aspect. In an aspect, the light sources 218/220 are separated from the light detectors 222/224, and the first light detector 222 is separated from the second light detector 224 are separated from one another by a sensor mount 912 affixed to the aperture plate 702. In an aspect, the sensor mount 912 ensures that light from the light sources 218/220 does not reach the light detectors 222/224 without coupling through the skin of the patient 202. The separation between the first light detector 222 within the first detection well 908 and the second light detector 224 within the second detection well 910 ensures that the fluorescence signal produced by the exogenous fluorescent agent within the tissues of the patient 202 is distinguishable from the unfiltered excitation light introduced by the first light source 218.

[0070] Referring again to FIG. 9, the sensor mount 912 may be aligned to a circuit board (not shown) containing the light sources 218/220 and light detectors 222/224 using alignment pins 914 and held in place using screws 916. In an aspect, the sensor mount 912 may be affixed to the circuit board containing the light sources 218/220 and light detectors 222/224 using a light absorbent adhesive including, but not limited to, black epoxy. In this aspect, this light-resistant joint between the circuit board and the sensor mount 912 inhibits leakage of light between the light sources 218/220 and the light detectors 222/224, and further inhibits the leakage of light between the first light detector 222 and the second light detector 224. The apertures 704 configured to transmit light to and from the skin underlying the contact surface 606 of the sensor head 204 are formed through a structurally separate aperture plate 702 (see FIG. 7) to

provide for precise alignment of the apertures 704 to the corresponding light sources 218/220 and light detectors 222/224, described in additional detail herein below.

[0071] In various aspects, the sensor mount 912 may further provide electrical shielding for any sensitive electrical devices within the sensor head 204 including, but not limited to, the light detectors 222/224. In one aspect, the sensor mount 912 may be constructed of an electrically conductive material including, but not limited to: aluminum and aluminum alloy. In this aspect, the sensor mount 912 may be electrically coupled to the ground of the circuit board using conductive screws 916. In addition, any glass windows positioned within the source well 902 and/or detector wells 908/910 adjacent to the aperture plate 702 including, but not limited to, an optical filter 244 and clear glass 246 as described herein below (see FIG. 2) may further include an electrically conductive coating. Non-limiting examples of suitable electrically conductive coatings for the glass windows of the sensor mount include a conductive indium tin oxide (ITO) coating and any other suitable transparent and electrically conductive coating.

[0072] Without being limited to any particular theory, the conductive material of the sensor mount 912 provides a partial Faraday cage to shield the electrically sensitive detectors 222/224 from electrical noise generated by or conducted through the patient's body. The partial Faraday cage provided by the sensor mount 912 may be completed with the conductive ITO coating on the glass windows within the source well 902 and/or detector wells 908/910. In an aspect, the electrically conductive coating on the glass windows, such as an ITO coating, are sufficiently conductive to provide electrical shielding while remaining sufficiently transparent for the transmission of light to and from the skin surface of the patient 202. In another aspect, the ITO coating of each glass window may be grounded to an electrically conductive sensor mount 912 using any known electrical grounding method including, by not limited to: a wire connecting the glass coating to the sensor mount 912 that is attached at both wire ends with conductive epoxy, or attaching the coated glass directly to a glass fitting such as a ledge or frame formed within each of the source well 902 and/or detector wells 908/910 using an electrically conductive epoxy.

[0073] In various aspects, the contact surface 606 of the housing 600 may be attached to the patient's skin using a biocompatible and an adhesive material 610 including, but not limited to, a clear double-sided medical grade adhesive, as illustrated in FIG. 6 and FIG. 7. Any adhesive material selected to be optically transmissive at the excitation and emission wavelengths used by the system 100 as described herein. The adhesive material 610 may be positioned on the contact surface 606 such that the adhesive material covers the apertures 704, but exposes the temperature sensor opening 706 to ensure sufficient thermal contact with the skin of the patient 202. In one aspect, the sensor head 204 may be further secured to the patient 202 as needed using one or more additional biocompatible medical fastener devices including, but not limited to: Tegaderm bandages, medical tape, or any other suitable biocompatible medical fastener devices.

[0074] In an aspect, the contact surface 606 may be located near the front edge of the sensor head 204 to provide for accurate positioning of the contact surface 606 on a selected region of the patient's skin. In another aspect, the

apertures 704 may be positioned towards the center of the contact surface 606 to reduce ambient light ingress. Without being limited to any particular theory, ambient light may enter one or more of the apertures 704 due to incomplete adhesion of the contact surface 606 to the patient's skin and/or due to the propagation of ambient light passing through the patient's exposed skin situated just outside of the footprint of the contact surface 606 into the apertures 704.

[0075] Referring again to FIG. 6, the bottom surface 608 of the sensor head 204 curves away from the plane of the contact surface 606 to enable attachment of the sensor head 204 to varied body type and locations. For attachment of the sensor head 204 to relatively flat or concave surfaces, any gap 612 between the bottom surface 608 and the skin surface of the patient 202 may be filled with a biocompatible foam to ensure consistent contact with the patient 202.

#### i) Light Sources

[0076] In various aspects, each sensor head 204 includes a first light source 218 and a second light source 220 configured to deliver light to a first region 206 of a patient 202. The first light source 218 is configured to deliver the light at the excitatory wavelength and the second light source 220 is configured to deliver light at the emission wavelength. In one aspect, the excitatory wavelength may be selected to fall within a spectral range at which the exogenous fluorescent agent exhibits relatively high absorbance. In another aspect, the emission wavelength may be selected to fall within a spectral range at which the exogenous fluorescent agent exhibits relatively high emission. The exogenous fluorescent agent may be selected for enhanced contrast relative to other chromophores within the tissues of the patient 202 including, but not limited to hemoglobin within red blood cells and/or melanin within melanocytes. In various aspects, the exogenous fluorescent agent may be selected to conduct measurements within spectral ranges with lower variation in absorption by other chromophores such as hemoglobin within the tissues of the patient 202 during use.

[0077] Without being limited to any particular theory, hemoglobin (Hb) is an absorber of visible light in the tissues of the patient 202, and has the potential to interfere with the measurements of fluorescence of the exogenous fluorescent agent if the Hb absorbance varies over the measurement period of the system 200. Because hemoglobin (Hb) enables gas exchange within virtually all tissues containing circulatory vessels, virtually all tissues are vulnerable to interference with fluorescence measurements of the system 200 due to fluctuations in hemoglobin concentration. Within most tissues, externally applied pressure may cause blood pooling which may be manifested as an apparent decay of the fluorescence measured at the skin surface. Periodic opening and closing of blood vessels ("vasomotion") near the surface of the skin may also cause fluctuations in hemoglobin concentration which may introduce additional noise in to measurements of fluorescence of the exogenous fluorescent agent by the system 200. Further, in some patients 202, such as those with pulmonary disorders, variation in the Hb oxygenation state may also be observed, leading to additional potential variations in the background skin absorbance due to differences in the absorption spectra of deoxyhemoglobin (Hb) and oxyhemoglobin (HbO<sub>2</sub>), shown illustrated in FIG. 3.

**[0078]** In an aspect, the excitation and emission wavelengths for the exogenous fluorescent agent may be selected to coincide with a pair of HbO<sub>2</sub>/Hb isosbestic points, each isosbestic point defined herein as a wavelength characterized by about equal light absorbance by HbO<sub>2</sub> and Hb. Without being limited to any particular theory, fluorescence measurements conducted at each isosbestic wavelength are less sensitive to variation due to changes in the oxygenation of hemoglobin, so long as the combined concentration of HbO<sub>2</sub> and Hb remains relatively stable during measurements of fluorescence by the system **200**. Non-limiting examples of Hb/HbO<sub>2</sub> isosbestic wavelengths include: about 390 nm, about 422 nm, about 452 nm, about 500 nm, about 530 nm, about 538 nm, about 545 nm, about 570 nm, about 584 nm, about 617 nm, about 621 nm, about 653 nm, and about 805 nm.

**[0079]** In various aspects, the excitation and emission wavelengths may be selected based on the absorption and emission wavelengths of the selected exogenous fluorescent agent of the system **200**. In one aspect, the excitatory wavelength may be an HbO<sub>2</sub>/Hb isosbestic wavelength and simultaneously may be a wavelength within a spectral range of high absorbance of the exogenous fluorescent agent. In another aspect, the emission wavelength may be an HbO<sub>2</sub>/Hb isosbestic wavelength and simultaneously may be a wavelength within a spectral range of emission by the exogenous fluorescent agent. Table 3 provides a summary of HbO<sub>2</sub>/Hb isosbestic wavelengths within the spectral range of 200 nm to about 1000 nm. FIG. 4 is a graph of the absorption spectra used to identify the HbO<sub>2</sub>/Hb isosbestic wavelengths of Table 1.

TABLE 1

HbO <sub>2</sub> /Hb Isosbestic Wavelengths $\lambda = 200\text{-}1000$ nm			
Excitation Wavelength (nm)	Hb Molar Extinct. Coeff. (M <sup>-1</sup> cm <sup>-1</sup> )	HbO <sub>2</sub> dA/d $\lambda$ (M <sup>-1</sup> cm <sup>-1</sup> nm <sup>-1</sup> )	Hb dA/d $\lambda$ (M <sup>-1</sup> cm <sup>-1</sup> nm <sup>-1</sup> )
260	$1.2 \times 10^5$	$1.8 \times 10^3$	$6.3 \times 10^2$
288	$1.1 \times 10^5$	$-2.9 \times 10^3$	$-3.4 \times 10^3$
298	$7.0 \times 10^4$	$-3.3 \times 10^3$	$-3.2 \times 10^3$
314	$6.5 \times 10^4$	$1.6 \times 10^3$	$1.5 \times 10^3$
324	$8.2 \times 10^4$	$1.9 \times 10^3$	$1.8 \times 10^3$
340	$1.1 \times 10^5$	$6.5 \times 10^2$	$1.6 \times 10^3$
390	$1.7 \times 10^5$	$1.0 \times 10^4$	$5.1 \times 10^3$
422	$4.3 \times 10^5$	$-2.6 \times 10^4$	$1.3 \times 10^4$
452	$6.3 \times 10^4$	$-2.3 \times 10^3$	$-1.7 \times 10^4$
500	$2.1 \times 10^4$	$-1.7 \times 10^2$	$4.8 \times 10^2$
530	$3.9 \times 10^4$	$2.0 \times 10^3$	$7.2 \times 10^2$
545	$5.1 \times 10^4$	$-1.3 \times 10^3$	$7.0 \times 10^2$
570	$4.5 \times 10^4$	$2.2 \times 10^3$	$-9.0 \times 10^2$
584	$3.4 \times 10^4$	$-4.1 \times 10^3$	$-7.1 \times 10^2$
738	$1.1 \times 10^3$	$6.8 \times 10^0$	$3.5 \times 10^0$
796	$8.0 \times 10^2$	$8.8 \times 10^0$	$1.1 \times 10^1$

**[0080]** By way of illustrative example, FIG. 3 is a graph summarizing the absorption spectra for HbO<sub>2</sub> and Hb, as well as the absorption and emission spectra of frequency spectra of MB-102, an exogenous fluorescent agent in one aspect. Emission spectra for a blue LED light source and a green LED light source are also shown superimposed over the other spectra of FIG. 3. In this aspect, the system **200** may include a blue LED as the first light source **218**, and the excitatory wavelength for the system **200** may be the isosbestic wavelength of about 450 nm. As listed in Table 1 and shown in FIG. 3, the Hb absorbance spectra is strongly

sloped at the isosbestic wavelengths of about 420 nm to about 450 nm (see columns 3 and 4 of Table 1), indicating that the relative absorbance of HbO<sub>2</sub> and Hb at the isosbestic wavelength of about 450 nm is sensitive to small changes in excitatory wavelength. However, at wavelengths above about 500 nm, the HbO<sub>2</sub>/Hb spectra are less steeply sloped, and a broader band light source including, but not limited to, an LED with a bandpass filter may suffice for use as a first light source **218**.

**[0081]** In another aspect, the excitatory wave length may be selected to enhance the contrast in light absorbance between the exogenous fluorescent agent and the chromophores within the tissues of the patient **202**. By way of non-limiting example, as shown in FIG. 3 at the isosbestic wavelength of 452 nm, the light absorption of the MB-102 is more than three-fold higher than the light absorption of the HbO<sub>2</sub> and the Hb. Without being limited to any particular theory, a higher proportion of light illuminating the tissue of the patient **202** at a wavelength of about 450 nm will be absorbed by the MB-102 relative to the HbO<sub>2</sub> and Hb, thus enhancing the efficiency of absorption by the MB-102 and reducing the intensity of light at the excitatory wavelength needed to elicit a detectable fluorescence signal.

**[0082]** In various aspects, a second isosbestic wavelength may also be selected as the emission wavelength for the system **200**. By way of non-limiting example, FIG. 3 shows an emission spectrum of the MB-102 exogenous contrast agent that is characterized by an emission peak at a wavelength of about 550 nm. In this non-limiting example, the isosbestic wavelength of 570 nm may be selected as the emission wavelength to be detected by first and second detectors **222/224**. In various other aspects, the emission wavelength of the system **200** may be selected to fall within a spectral range characterized by relatively low absorbance of the chromophores within the tissues of the patient **202**. Without being limited to any particular theory, the low absorbance of the chromophores at the selected emission wavelength may reduce the losses of light emitted by the exogenous fluorescent agent and enhancing the efficiency of fluorescence detection.

**[0083]** In various aspects, the first light source **218** and the second light source **220** may be any light source configured to deliver light at the excitatory wavelength and at the emission wavelength. Typically, the first light source **218** delivers light at an intensity that is sufficient to penetrate the tissues of the patient **202** to the exogenous fluorescent agent with sufficient intensity remaining to induce the emission of light at the emission wave length by the exogenous fluorescent agent. Typically, the first light source **218** delivers light at an intensity that is sufficient to penetrate the tissues of the patient **202** to the exogenous fluorescent agent with sufficient intensity remaining after scattering and/or absorption to induce fluorescence at the emission wave length by the exogenous fluorescent agent. However, the intensity of light delivered by the first light source **218** is limited to an upper value to prevent adverse effects such as tissue burning, cell damage, and/or photo-bleaching of the exogenous fluorescent agent and/or the endogenous chromophores in the skin (“auto-fluorescence”).

**[0084]** Similarly, the second light source **220** delivers light at the emission wavelength of the exogenous fluorescent agent at an intensity configured to provide sufficient energy to propagate with scattering and absorption through the first region **206** of the patient and out the second region **208** and

third region **210** with sufficient remaining intensity for detection by the first light detector **222** and the second light detector **224**, respectively. As with the first light source **218**, the intensity of light produced by the second light source **220** is limited to an upper value to prevent the adverse effects such as tissue injury or photobleaching described previously.

**[0085]** In various aspects, the first light source **218** and the second light source **220** may be any light source suitable for use with fluorescent medical imaging systems and devices. Non-limiting examples of suitable light sources include: LEDs, diode lasers, pulsed lasers, continuous waver lasers, xenon arc lamps or mercury-vapor lamps with an excitation filter, lasers, and supercontinuum sources. In one aspect, the first light source **218** and/or the second light source **220** may produce light at a narrow spectral bandwidth suitable for monitoring the concentration of the exogenous fluorescence agent using the method described herein. In another aspect, the first light source **218** and the second light source **220** may produce light at a relatively wide spectral bandwidth.

**[0086]** In one aspect, the selection of intensity of the light produced by the first light source **218** and the second light source **220** by the system **200** may be influenced any one or more of at least several factors including, but not limited to, the maximum permissible exposure (MPE) for skin exposure to a laser beam according to applicable regulatory standards such as ANSI standard Z136.1. In another aspect, light intensity for the system **200** may be selected to reduce the likelihood of photobleaching of the exogenous fluorescent source and/or other chromophores within the tissues of the patient **202** including, but not limited to: collagen, keratin, elastin, hemoglobin within red blood cells and/or melanin within melanocytes. In yet another aspect, the light intensity for the system **200** may be selected in order to elicit a detectable fluorescence signal from the exogenous fluorescent source within the tissues of the patient **202** and the first light detector **222** and/or second light detector. In yet another aspect, the light intensity for the system **200** may be selected to provide suitably high light energy while reducing power consumption, inhibiting heating/overheating of the first light source **218** and the second light source **220**, and/or reducing the exposure time of the patient's skin to light from the first light detector **222** and/or second light detector.

**[0087]** In various aspects, the intensity of the first light source **218** and the second light source **220** may be modulated to compensate any one or more of at least several factors including, but not limited to: individual differences in the concentration of chromophores within the patient **202**, such as variation in skin pigmentation. In various other aspects, the detection gain of the light detectors may be modulated to similarly compensate for variation in individual differences in skin properties. In an aspect, the variation in skin pigmentation may be between two different individual patients **202**, or between two different positions on the same patient **202**. In an aspect, the light modulation may compensate for variation in the optical pathway taken by the light through the tissues of the patient **202**. The optical pathway may vary due to any one or more of at least several factors including but not limited to: variation in separation distances between the light sources and light detectors of the system **200**; variation in the secure attachment of the sensor head **204** to the skin of the patient **202**; variation in the light output of the light sources due to the exposure of the light sources to environmental factors such as heat and moisture; variation in the sensitivity of the light

detectors due to the exposure of the light detectors to environmental factors such as heat and moisture; modulation of the duration of illumination by the light sources, and any other relevant operational parameter.

**[0088]** In various aspects, the first light source **218** and the second light source **220** may be configured to modulate the intensity of the light produced as needed according to any one or more of the factors described herein above. In one aspect, if the first light source **218** and the second light source **220** are devices configured to continuously vary output fluence as needed, for example LED light sources, the intensity of the light may be modulated electronically using methods including, but not limited to, modulation of the electrical potential, current, and/or power supplied to the first light source **218** and/or the second light source **220**. In another aspect, the intensity of the light may be modulated using optical methods including, but not limited to: partially or fully occluding the light leaving the first light source **218** and the second light source **220** using an optical device including, but not limited to: an iris, a shutter, and/or one or more filters; diverting the path of the light leaving the first light source **218** and the second light source **220** away from the first region **206** of the patient using an optical device including, but not limited to a lenses, a mirror, and/or a prism.

**[0089]** In various aspects, the intensity of the light produced by the first light source **218** and the second light source **220** may be modulated via control of the laser fluence, defined herein as the rate of energy within the produced light beam. In one aspect, the laser fluence may be limited to ranges defined by safety standards including, but not limited to, ANSI standards for exposure to laser energy such as ANSI Z136.1. Without being limited to any particular theory, the maximum fluence of light delivered to a patient **202** may be influenced by a variety of factors including, but not limited to the wavelength of the delivered light and the duration of exposure to the light. In various aspects, the maximum fluence of light may range from about 0.003 J/cm<sup>2</sup> for light at delivered at wavelengths of less than about 302 nm to about 1 J/cm<sup>2</sup> for light delivered at wavelengths ranging from about 1500 nm to about 1800 nm for a duration of up to about 10 sec. For light delivered at wavelengths ranging from about 400 nm to about 1400 nm (visible/NIR light) the maximum fluence may be about 0.6 J/cm<sup>2</sup> for a duration of up to about 10 sec, and up to about 0.2 J/cm<sup>2</sup> for a duration ranging from about 10 sec to about 30,000 sec. For extended exposures, the delivered light is limited to a maximum power density (W/cm<sup>2</sup>) according to ANSI standards: visible/NIR light is limited to 0.2 W/cm<sup>2</sup> and far IR light is limited to about 0.1 W/cm<sup>2</sup>. Without being limited to a particular theory, extended exposure to light delivered at UV wavelengths is not typically recommended according to ANSI standards.

**[0090]** In another aspect, the fluence of light at the excitatory wavelength produced by the first light source **218** may be modulated in order to provide sufficient energy to propagate through the skin in the first region **206** of the patient **202** to the exogenous fluorescent agent without photobleaching, and to illuminate the exogenous fluorescent agent with energy sufficient to induce detectable fluorescence at the first light detector **222** and/or the second light detector **224**. In an additional aspect, the fluence of light at the emission wavelength produced by the second light source **220** may be modulated in order to provide sufficient energy to propagate

through the skin in the first region **206** of the patient **202** and through the skin in the second region **208** and the third region **210** without photobleaching to emerge as detectable light at the first light detector **222** and the second light detector **224**, respectively. By way of non-limiting example, the fluence of light produced by a light source at 450 nm or 500 nm may be limited to 1.5 and 5 mW/cm<sup>2</sup>, respectively, to prevent photo-bleaching.

**[0091]** In various aspects, the fluence of the light produced by the first light source **218** and the second light source **220** may be modulated by any suitable systems and/or devices without limitation as described herein above. This modulation may be enabled a single time during operation of the system **200**, and as a result, the fluence of the light produced by each of the first light source **218** and the second light source **220** may be relatively constant throughout the operation of the system **200**. In another aspect, the light modulation may be enabled at discrete times over the duration of operation of the system **200**, or the light modulation may be enabled continuously over the duration of operation of the system **200**.

**[0092]** In one aspect, the fluence of the light may be modulated via manual adjustment of any of the power source settings and/or optical device settings as described above when the system **200** is configured in an Engineering Mode. In another aspect, the fluence of the light may be modulated automatically via one or more control schemes encoded in the light source control unit of the controller **212** as described herein below. In this aspect, the degree of modulation may be specified at least in part on the basis of feedback measurements obtained by various sensors provide in the sensor head **204** of the system **200** including, but not limited to, additional light detectors **226** and temperature sensors **228** as described in additional detail herein below.

**[0093]** In various aspects, light produced by the first light source **218** and the second light source **220** are further characterized by a pulse width, defined herein as the duration of the produced light. Although pulse width is typically used to characterize the performance of a light source that produces light in discrete pulses, such as a pulsed laser, it is to be understood that the term “light pulse”, as used herein, refers to any discrete burst of light produced by a single light source at a single wavelength to enable the acquisition of a single measurement of fluorescence by the system **200**. Similarly, the term “pulse width”, as used herein, refers to the duration of a single light pulse produced by a single light source. The pulse width is typically selected based on one or more of at least several factors including, but not limited to: delivery of sufficient light energy to elicit detectable fluorescence from the exogenous fluorescent agent without photobleaching the exogenous fluorescent agent or other chromophores within the tissues of the patient **202**; compliance with safety standards for light delivery to patients such as ANSI standards; light delivery at sufficiently high rate to enable data acquisition at a rate compatible with real-time monitoring of renal function; performance capabilities of the selected light sources, light detectors, and other devices of the system **200**; preservation of the working life of light sources, light detectors, and other devices related to producing and detecting light energy; and any other relevant factors.

**[0094]** In various aspects, the pulse width of the light produced by the first light source **218** and the second light source **220** may be independently selected to be a duration

ranging from about 0.0001 seconds to about 0.5 seconds. In various other aspects, the pulse width of the light produced by the first light source **218** and the second light source **220** may be independently selected to be a duration ranging from about 0.0001 seconds to about 0.001 seconds, from about 0.0005 seconds to about 0.005 seconds, from about 0.001 seconds to about 0.010 seconds, from about 0.005 seconds to about 0.05 seconds, from about 0.01 seconds to about 0.1 seconds, from about 0.05 seconds to about 0.15 seconds, from about 0.1 seconds to about 0.2 seconds, from about 0.15 seconds to about 0.25 seconds, from about 0.2 seconds to about 0.3 seconds, from about 0.25 seconds to about 0.35 seconds, from about 0.3 seconds to about 0.4 seconds, from about 0.35 seconds to about 0.45 seconds, and from about 0.4 seconds to about 0.5 seconds. In one aspect, the pulse widths of the light produced by the first light source **218** and the second light source **220** are both about 0.1 seconds, as illustrated schematically in FIG. 5.

**[0095]** In another aspect, the light produced by the first light source **218** and the second light source **220** may be further characterized by a pulse rate, defined herein as the number of pulses produced by a light source per second. Although pulse rate is typically used to characterize the performance of a light source that produces light in discrete pulses, such as a pulsed laser, it is to be understood that the term “pulse rate”, as used herein, refers to the rate of production of a discrete light pulse by a single light source at a single wavelength in association with the acquisition of measurements of fluorescence by the system **200**. In various aspects, the pulse rate may be selected based on one or more of at least several factors including, but not limited to: compliance with safety standards for light delivery to patients such as ANSI standards; the performance capabilities of the selected light sources, light detectors, and other devices of the system **200**; light delivery rates compatible with data acquisition rates sufficiently rapid for real-time monitoring of renal function; preserving the working life of light sources, light detectors, and other devices related to producing and detecting light energy; and any other relevant factor.

**[0096]** In various aspects, the light sources are configured to deliver light into the tissues of the patient **202** at a single position such as a first region **206**, illustrated schematically in FIG. 2. In one aspect, the delivery of light at both the excitatory wavelength and the emission wavelength to the same first region **206** enables both light pulses to share at least a portion of the optical path traveled through the tissues of the patient **202** between the point of entry at the first region **206** and the point of detection at the second region **208** and the third region **210**. As discussed in detail herein below, this arrangement of optical paths enhances the quality of data produced by the system **200**.

**[0097]** In one aspect, the first light source **218** and the second light source **220** may be operatively coupled to a common means of light delivery. In one aspect (not illustrated) the first light source **218** and the second light source **220** may each be operatively coupled to a first optic fiber and a second optic fiber, respectively, and the first and second optic fibers may be joined to a third optic fiber configured to direct light from the first optic fiber and/or the second optic fiber into the first region **206** of the patient **202**. In another aspect, the first light source **218** and the second light source **220** may be operatively coupled to a common optic fiber or other optical assembly configured to direct the light from the



first light source **218** and/or the second light source **220** into the first region **206** of the patient **202**. In this aspect, the light produced by the first light source **218** and the second light source **220** may be directed in an alternating pattern into the common optic fiber or other optical assembly using an adjustable optical device including, but not limited to, dichroic mirror or a rotating mirror.

[**0098**] In an aspect, the system **200** may include the sensor head **204** provided with a sensor mount **912** configured with one or more wells within which the light sources **218/220** and light detectors **222/224** may be attached in a predetermined arrangement. In one aspect, illustrated in FIG. **9** and FIG. **10**, the first light source **218** and the second light source **220** may be situated within a source well **902** of the sensor mount **912** positioned within the sensor head **204** (see FIG. **9**). In an aspect, the source well **902** may contain a first LED light source **218** producing light at the excitation wavelength and a second LED light source **220** producing light at the emission wavelength operatively coupled to a single light delivery aperture **1002** (see FIG. **10**) formed through the aperture plate **702**, which ensures that both wavelengths of light (i.e. excitatory and emission) enter the skin of the patient **202** at approximately the same location including, but not limited to, a first region **206** as illustrated schematically in FIG. **2**. In an aspect, the source well **902** further contains a first monitor photodiode **904** and a second monitor photodiode **906**, which are used to correct for variations in output power from the LED light sources as described in further detail herein below.

[**0099**] In an aspect, only a fraction of the light energy produced by the LED light sources is delivered to the skin of the patient **202** via the single light delivery aperture **1002**. In one aspect, the skin of the patient **202** receives about 1% of the light energy produced by the LED light sources. In various other aspects, the skin of the patient **202** receives about 2%, about 3%, about 4%, about 5%, about 7.5%, about 10%, about 20%, and about 50% of the light energy produced by the LED light sources. Without being limited to any particular theory, the fraction of light produced by the LED light sources delivered to the skin of the patient **202** may be increased by the incorporation of additional optical elements configured to focus and/or direct the light from each LED light source to the light delivery aperture **1002**. In another aspect, a diffuser may be used to mix the output of the light sources so that the light energy is rendered homogeneous at the surface of the skin of the patient.

## ii) Light Detectors

[**0100**] Referring again to FIG. **2**, the system **200** further includes a first light detector **222** and a second light detector **224** in various aspects. In an aspect, the first light detector **222** is configured to measure unfiltered light emitted from the tissue of the patient **202** at the second region **208**, and the second light detector **224** is configured to measure filtered light emitted from the tissue of the patient **202** at the third region **210**. In this aspect, the second light detector **224** further comprises an optical filter **244** configured to block light at the excitation wavelength. As a result, the first light detector **222** is configured to measure light received at both the excitation and emission wavelengths and the second light detector **224** is configured to detect light received at the emission wavelength only. Combined with the illumination of the tissues of the patient **202** with light at the excitatory wavelength only and at the emission wavelength only in an

alternating series (see FIG. **5**) the measurements from the first light detector **222** and a second light detector **224** may be analyzed as described herein below to measure the fluorescence of an exogenous fluorescence agent and to correct the fluorescence measurements by removing the effects of the diffuse reflectance of light according to the correction methods described herein below.

[**0101**] In various aspects, the second region **208** and third region **210** within the tissues of the patient **202**, from which light is detected by the first light detector **222** and a second light detector **224**, respectively, are each separated by a nominal distance from the first region **206** to which light produced by the first light source **218** and the second light source **220** is delivered. This nominal separation distance may be selected to balance two or more effects that may impact the quality of data detected by the light detectors. Without being limited to any particular theory, as the nominal separation distance increases, the total detected signal from the light detectors may decrease due to light scattering along the longer optical path between light source and light detector. This effect may be mitigated by the choice of emission wavelength, which may result in a less pronounced decrease in the detected fluorescence signal (i.e. light at the emission wavelength) relative to the signals associated with detected light at the excitation wavelengths as the nominal separation distance increases. Longer nominal separation distances result in higher sensitivity to signal changes due to changing tissue optical properties.

[**0102**] In one aspect, the nominal separation distance may range from 0 mm (i.e. collocation of light sources and light detectors) to about 10 mm. In various other aspects, the nominal separation distance may range from about 1 mm to about 8 mm, from about 2 mm to about 6 mm, and from about 3 mm to about 5 mm. In various additional aspects, the nominal separation distance may be 0 mm, about 1 mm, about 2 mm, about 3 mm, about 4 mm, about 5 mm, about 6 mm, about 8 mm, and about 10 mm. In one aspect, the nominal separation distance may be about 4 mm to balance these competing effects of logarithmic drop-off of signal and reduced size of the background signal relative to the signal from the exogenous fluorescent agent.

[**0103**] Referring again to FIG. **9**, the first light detector **222** may be positioned within a first detection well **908** of the sensor mount **912** and the second light detector **224** may be positioned within a second detection well **910** of the sensor mount **912** within the sensor head **204**. The first light detector **222** and the second light detector **224** may receive light from tissue of the patient **202** through a first detector aperture **1004** and second detector aperture **1006**, respectively. In an aspect, the first detector aperture **1004**, the second detector aperture **1006**, and the light delivery aperture **1002** are mutually separated from one another by the nominal separation distance disclosed herein above including, but not limited to, a nominal separation distance of 4 mm. In an aspect, the first detection well **908**, second detection well **910**, and light source well **902** of the sensor mount **912** may be optically isolated from one another to ensure that light from the light sources **218/220** does not reach the light detectors **222/224** without coupling through the skin of the patient **202**. The separation between the two detection wells **908/910** ensures that the detected fluorescence signal from the exogenous fluorescent agent is distinguishable from the unfiltered excitation light, as described in detail herein below.

[10104] In an aspect, the three apertures 704 of the aperture plate 702 (see FIG. 7) are circular with a diameter ranging from about 0.5 mm to about 5 mm. In various other aspects, the diameters of the apertures may range from about 0.5 mm to about 1.5 mm, about 1 mm to about 2 mm, about 1.5 mm to about 2.5 mm, about 2 mm to about 3 mm, about 2.5 mm to about 3.5 mm, about 3 mm to about 4 mm, about 3.5 mm to about 4.5 mm, and about 4 mm to about 5 mm.

[10105] In one aspect, the three apertures 704 of the aperture plate 702 are circular apertures with a diameter of about 1 mm diameter. This finite width of the apertures may result in an effective source-detector separation of less than the nominal separation distance because of the logarithmic drop-off of signal with increasing separation distance from the light sources at the skin interface of the sensor head 204.

[10106] In various aspects, the light detectors 222/224 of the system 200 may be any suitable light detection device without limitation. Non-limiting examples of suitable light detection devices include: photoemission detectors such as photomultiplier tubes, phototubes, and microchannel plate detectors; photoelectric detectors such as LEDs reverse-biased to act as photodiodes, photoresistors, photodiodes, phototransistors; and any other suitable light detection devices. In an aspect, the light detectors 222/224 are sufficiently sensitive to detect the fluorescence emitted by the exogenous fluorescent agents within the tissues of patients 202 that include melanin ranging from about 1% to about 40% melanin in the epidermis and blood volume ranging from about 0.5% to about 2% of the skin volume. In one aspect, the light detectors 222/224 may be silicon photomultiplier (SPM) devices.

[10107] In an aspect, the first light detector 222 may be configured to detect light at both the excitatory frequency and at the emission frequency, and the second light detector 224 may be configured to detect light at the emission frequency only. In one aspect, the second light detector 224 may respond only to light of the emission wavelength as a result of the design and materials of the sensor elements of the second light detector 224. In another aspect, the second light detector 224 may respond to a wider range of light wavelengths, but may be positioned downstream from an optical filter configured to pass only the portion of incoming light with the emission wavelength and further configured to block the passage of light wavelengths outside of the emission wavelength.

[10108] Any suitable optical filter may be selected for use with the second light detector 224 to detect light selectively at the emission wavelength. Non-limiting examples of suitable optical filters include absorptive filters and interference/dichroic filters. Without being limited to any particular theory, the performance of an absorption filter does not vary significantly with the angle of incident light, whereas the performance of an interference/dichroic filter is sensitive to the angle of incident light and may require additional collimation optics to effectively filter the Lambertian light distribution representative of light emitted from the skin of the patient 202.

[10109] In one aspect, the second light detector 224 may be positioned downstream of an absorptive long-pass filter configured to pass light above a predetermined wavelength to the second light detector 224. By way of non-limiting example, the second light detector 224 may be positioned downstream of a long-pass OG530 filter configured to pass light with wavelengths above about 530 nm. Other non-

limiting examples of suitable filters include a Hoya O54 filter and a Hoya CM500 filter.

[10110] In various aspects, an absorption filter 244 configured to absorb excitation wavelength light may be positioned within the second detection well 910 between the second light detector 224 and the second detector aperture 1006. In one aspect, the absorption filter 244 may be constructed from OG530 Schott glass. The thickness of the absorption filter 244 may be selected to enable an optical density sufficient to filter the excitation light by about three orders of magnitude. In one aspect, the thickness of the absorption filter 244 may range from about 1 mm to about 10 mm. In various other aspects, the thickness of the absorption filter 244 may range from about 1 mm to about 8 mm, from about 2 mm to about 6 mm, and from about 3 mm to about 5 mm. In various additional aspects, the thickness of the absorption filter 244 may be about 1 mm, about 2 mm, about 3 mm, about 4 mm, about 5 mm, about 6 mm, about 7 mm, about 8 mm, about 9 mm, and about 10 mm. In one aspect, the absorption filter 244 is a 3-mm thick filter constructed of OG530 Schott glass.

[10111] In an additional aspect, an optical diffuser may be provided within the light source well 902. In this aspect, the optical diffuser enables mixing of the light entering the light source well 902 from the first and second light sources 218/220. By mixing the light from the first and second light sources 218/220 using the optical diffuser prior to illumination of the first region 206 of the patient 202, the similarity of the optical paths taken by emission-wavelength light and excitation-wavelength light through the tissues of the patient is enhanced relative to the corresponding optical paths taken by unmixed light, thereby reducing a potential source of variation.

[10112] In an aspect, a transparent material configured to pass light of both the excitatory and emission wavelengths may be positioned within the first detection well 908 between the first light detector 222 and the first detector aperture 1004. In this aspect, the transparent material may be any material with similar optical properties to the material of the absorption filter 244 including, but not limited to, thickness and index of refraction. In one aspect, the transparent material within the first detection well 908 may be fused silica glass of the same thickness as the absorption filter 244.

[10113] By way of non-limiting example, the transmission spectrum of the OG 530 filter is provided in FIG. 3. As illustrated in FIG. 3, the transmission spectrum of the OG 530 filter overlaps with the emission spectrum of the MB-102 exogenous fluorescent agent and the emission spectrum of a green LED used as a second light source 220 (emission wavelength). In addition, the transmission spectrum of the OG 530 filter excludes the emission spectrum of the blue LED used as a first light source 218 and the absorbance spectrum of the MB-102 exogenous fluorescent agent (excitation wavelength).

[10114] In an aspect, the transparent material such as glass 246 and the absorption filter 244 may be secured to ledges formed within the first detection well 908 and the second detection well 910, respectively. The transparent material such as glass 246 and the optical filter 244 may be secured in place using an opaque and/or light absorbing adhesive including, but not limited to, black epoxy to ensure that all light received through the first detector aperture 1004 and the second detector aperture 1006 travels through the optical

filter **244** or glass **246** before detection by the first and second light detectors **222/224**. In another aspect, the sides of the optical filter **244** or glass **246** may be painted black with a light-absorbing coating including, but not limited to, India ink to ensure that light does not reach the first and second light detectors **222/224** without passing through the optical filter **244** or glass **246**.

[0115] In an aspect, the height of the detection wells **908/910**, combined with the diameter of the detector apertures **1004/1006** may limit the fraction of the light emitted from the second region **208** and third region **210** of the patient's skin that reaches the active areas of the light detectors **222/224** due to the Lambertian distribution of the angle of the light leaving the patient's skin. In one aspect, the fraction of light emitted from the second region **208** and third region **210** of the patient's skin received by the light detectors **222/224** may range from about 5% to about 90%. In various other aspects, the fraction of light may range from about 5% to about 15%, from about 10% to about 20%, from about 15% to about 25%, from about 20% to about 30%, from about 25% to about 35%, from about 30% to about 40%, from about 35% to about 45%, from about 40% to about 60%, from about 50% to about 70%, and from about 60% to about 90%.

[0116] In one aspect, for the sensor head **204** illustrated in FIG. 6 and FIG. 7 with 1-mm diameter apertures **1002/1004/1006**, about 10% of the light emitted from the surface of the patient's skin may reach the active area of the light detectors **222/224** to be detected. In various aspects, the sensor head **204** may further include additional optical elements including, but not limited to, lenses and/or prisms configured to compensate for the Lambertian distribution of light angles in order to enhance the fraction of light emitted from the patient's skin that is directed to the active area of the light detectors **222/224**.

### iii) Temperature Sensors

[0117] Referring to FIG. 2, the sensor head **204** may further include one or more additional temperature sensors **228** configured to monitor temperatures of various regions within the sensor head **204** and in the vicinity of the sensor head **204**. Non-limiting examples of suitable regions for which the temperature may be monitored by the one or more additional temperature sensors **228** include: temperature at the skin surface of the patient **202**; temperature in the vicinity of the first light source **218** and/or second light source **220**; ambient temperature outside of the sensor head **204**; temperature of housing **600** of sensor head **204**; and any other suitable region. In one aspect, additional temperature sensors **228** may be configured to monitor the temperatures in the vicinity of temperature-sensitive electrical components including, but not limited to: light sources **218/220** such as LEDs, light detectors **222/224** such as silicon photomultipliers (SPMs), and any other temperature-sensitive electrical components of the sensor head **204**. In some aspects, one or more temperatures measured by one or more additional temperature sensors **228** may be used as feedbacks in a control method for one or more of the temperature-sensitive devices of the system **200** as described herein below.

[0118] By way of non-limiting example, a temperature measurement may be used to control the amount of light energy produced by an LED used as a first or second light source **218/220**. In this example, LED temperatures measured by an second temperature sensor **1108** (see FIG. 11)

may be used in a control scheme to modulate the amount of power supplied to an LED light source to compensate for the effect of LED temperature on the light output of the LED. In another aspect, additional temperature sensors **228** may monitor the temperatures of LED light sources **218/220** to monitor and/or compensate for temperature variations of the LEDs as well as to monitor and/or compensate for temperature-dependent transmission of the optical filters to maintain relatively constant output wavelengths.

[0119] By way of another non-limiting example, an additional temperature sensor **228** may be included in the sensor head **204** in the form of a thermistor **816** (see FIG. 8) configured to monitor the temperature of the housing **600** in the vicinity of the contact surface **606** of the sensor head **204**. Referring to FIG. 7, FIG. 8, and FIG. 9, the thermistor **816** may be epoxied into the temperature sensor opening **706** in the aperture plate **702** in one aspect. In this aspect, the space **918** between the circuit board (not shown) and the lower housing **604** may be filled with a thermally conductive putty to ensure good thermal conduction and dissipation.

[0120] In this example, the measured housing temperature may be used to modulate the light output of the sensor head **204** to prevent overheating of the skin of the patient **202** during use. In another aspect, additional temperature sensors **228** may monitor the temperatures of LED light sources **218/220** to monitor and/or compensate for temperature variations of the LEDs to enable the maintenance of relatively constant output wavelengths by the LED light sources **218/220**.

[0121] In an additional aspect, temperatures measured by one or more additional temperature sensors **228** may provide for subject safety by disabling one or more electrical devices including the light sources **218/220** and/or light detectors **222/224** if an over-temperature condition is detected. In one aspect, an over-temperature condition may be indicated if the case temperature detected by the thermistor **816** is greater than about 40° C. In various other aspects, an over-temperature condition may be detected if the case temperature is greater than about 40.5° C. or greater than about 41.0° C.

### B. Controller

[0122] Referring again to FIG. 2, the system **200** in various aspects may include a controller **212** configured to operate the light sources **218/220** and light detectors **222/224** in a coordinated fashion to obtain a plurality of measurements used to obtain the fluorescence of the exogenous fluorescent agent within the tissues of the patient **202**, to correct the fluorescence data to remove the effects of the diffuse reflectance of light as described herein below, and to transform the fluorescence measurements into a parameter representative of the renal function of the patient **202**. FIG. 11 is a schematic diagram of an electronic circuit **1100** that illustrates the arrangement of various electrical components that enable the operation of the system **200** in an aspect. In one aspect, the controller **212** may be a computing device further including an operation unit **214** and a display unit **216**.

#### i) Light Source Control Unit

[0123] Referring again to FIG. 2, the controller **212** may include a light source control unit **230** configured to operate the first light source **218** and the second light source **220** to

produce light at the excitation wavelength and emission wavelength, respectively in a coordinated manner to produce a repeating pulse sequence as illustrated schematically in FIG. 5. In various aspects, the light source control unit 230 may produce a plurality of light control signals encoding one or more light control parameters including, but not limited to: activation or deactivation of each light source; relative timing of activation and deactivation of each light source to enable light pulse width, pulse repetition rate, electrical power delivered to the light source or other parameter associated with light pulse fluence or light pulse power; other light source-specific parameters controlling the light output of the light source; and any other relevant light control parameter. In an aspect, the light source control unit 230 may receive one or more feedback measurements used to modulate the plurality of control signals to compensate for variations in performance of the light sources in order to maintain a relatively stable output of light from the light sources. Non-limiting examples of feedback measurements used by the light source control unit 230 include: light output of the light sources 218/220 measured within the source well 902 by the first monitor photodiode 904 and the second monitor photodiode 906, respectively, temperatures of the light sources 218/220, and any other feedback measurement relevant to monitoring the performance of light sources 218/220.

[0124] By way of non-limiting example, the light source control unit 230 may be configured to operate LED light sources 218/220. In this example, the light output of the LED light sources 218/220 may be controlled by controlling the magnitude of current provided to each LED. In an aspect, the light source control unit 230 may include at least one waveform generator 1122 including, but not limited to, a field programmable gate array FPGA with a 16-bit DAC 1124 operatively coupled to a LED current source 1126, as illustrated in FIG. 11. In an aspect, waveforms generated by the at least one waveform generator 1122 including, but not limited to square waves, may control the output from the LED current source 1126. In an aspect, the magnitude of the current supplied to the LED light sources 218/220 may be adjustable based on the waveform signals provided by the waveform generator/FPGA 1122.

[0125] Referring to FIG. 5, in one aspect, each light pulse sequence 500 includes an emission wavelength light pulse 502 and an excitatory wavelength light pulse 504 that are both made up of a plurality of square waves 506 produced by the first and second LED light sources 218/220. Referring to FIG. 11, square waves generated by the waveform generator 1122 are received by the LED current source 1126. The current generated by the LED current source includes a square waveform similar to the waveform generated by the waveform generator 1122. Without being limited to any particular theory, because the intensity of light produced by the LED light sources 218/220 is proportional to the magnitude of the current received, the light produced by the LED light sources 218/220 also includes the square waveform as illustrated in FIG. 5. In another aspect, discussed in additional detail below, the square waves produced by the waveform generator 1122 may also be used by the acquisition unit 234 in a synchronous detection method to reduce the effects of various confounding factors including, but not limited to, the detection of ambient light, from the detector signals generated by the light detectors 222/224 during

illumination of the tissues of the patient at the emission and excitatory wavelengths by the first and second light sources 218/220, respectively.

[0126] In various other aspects, a variety of alternate LED pulse modulation schemes may be equivalently employed without limitation. In one aspect, the excitation and emission pulses are delivered in an alternating series interspersed with a dark period after each pulse. In another aspect, the first and second LED light sources 218/220 are each modulated with a 50% duty cycle but at different modulation frequencies, allowing the signals associated with the excitation and emission pulses to be separated by frequency filtering.

[0127] Without being limited to any particular theory, the overall optical power delivered to the patient's skin may be limited by at least two factors: photobleaching of the exogenous fluorescent agent and/or endogenous chromophores, as well as overheating of the patient's tissues illuminated by the system 200. In one aspect, tissue heating may impose an absolute limit of about 9 mW on the optical power that can be delivered to the skin, based on safety standards including, but not limited to, ANSI/IESNA RP-27.1-05. In another aspect, photobleaching of the skin autofluorescence associated with endogenous chromophores including, but not limited to, collagen, hemoglobin, and melanin may contribute a background signal to the measured fluorescence that remains relatively constant so long as no autobleaching of the chromophores occurs. This constant autofluorescence background may be subtracted from the raw fluorescence signal, but if autofluorescence varies over time due to photobleaching, this background correction may interfere with the kinetic calculation of the renal decay time constant (RDTC). In an aspect, the light output power of the first light source 218 and/or second light source 220 may be limited to levels below power thresholds associated with chromophore photobleaching.

[0128] Referring again to FIG. 9, the light output of the light sources 218/220 may be measured using monitor photodiodes 904/906 in various aspects. Because the light intensity reaching these monitor photodiodes 904/906 is typically much stronger than the light intensity that reaches the light detectors 222/224 through the patient's skin, less sensitive light detecting devices including, but not limited to, PIN photodiodes may be used to monitor the output of the light sources 218/220.

[0129] In various aspects, the system 200 may be configured to operate over a range of skin tones observed in the human population. Without being limited to any particular theory, variations in skin tones between different patients 202 may result in variations in the detected fluorescence signals ranging over about three orders of magnitude. In addition, variations in the concentrations of exogenous fluorescent agent within each patient 202 may vary over a range of about two orders of magnitude due to renal elimination of the agent over time. In various aspects, the system 200 may be configured to detect fluorescence from the endogenous fluorescent agent over an intensity range of more than five orders of magnitude. In these various aspects, the system 200 may be configured by modulation of at least one operational parameter including, but not limited to: magnitude of light output by the light sources 218/220 and sensitivity of light detectors 222/224 corresponding to detector gains.

[0130] In one aspect, the intensity of the light output by the light sources 218/220 may be manually set by a user via

the operation unit **214**. In another aspect, the light source control unit **230** may be configured to modulate the intensity of light produced by the light sources **218/220** automatically. In an aspect, the light source control unit **230** may be configured to control the light intensity produced by the LED light sources **218/220** within a range of normalized output intensities from 0 (off) to 1 (maximum power). In an aspect, the intensity of the light sources **218/220** may be set by the light source control unit **230** in coordination with the detector gains of the light detectors **222/224** set by the light detector control unit **232**, as described herein below.

[0131] In one aspect, signals obtained during the first **10** detection cycles obtained by the system **200** after initialization of data acquisition, but prior to the injection of the exogenous fluorescent agent, may be used by the light source control unit **230** to automatically adjust the light intensity produced by the LED light sources **218/220**, as well as the gain of the light detectors **222/224**. In this example, the initial detection cycle may be obtained with the LED light sources **218/220** set at about 10% of maximum LED intensity (corresponding to a normalized output intensity of 0.1) and with a low gain setting for the light detectors **222/224**. Based on the detected intensity of light received at the light detectors **222/224** at the excitation and emission wavelengths for one detection cycle, the corresponding LED intensities may be modulated to enable the analog signals produced by the light detectors **222/224** to correspond to about  $\frac{1}{4}$  of the full range of each detector analog-to-digital convertor (ADC) at the low detector gain setting. If the signals produced by the light detectors **222/224** in response to the light produced by the second LED light source **220** at the emission wavelength do not agree, the larger signal may be used to modulate the power setting of the second LED light source **220**. If the method described above results in modulation to an LED intensity setting higher than the maximum intensity (corresponding to a normalized output intensity of 0.1), the LED intensity setting is set to the maximum setting. Without being limited to any particular theory, the targeted levels of signals produced by the light detectors **222/224** (i.e.  $\frac{1}{4}$  of the ADC range) is selected to reserve additional light detection capacity to detect signals resulting from variations in optical properties of the tissues of the patient **202** during the study due to any one or more of a plurality of factors including, but not limited to, the introduction of the exogenous fluorescent agent into the patient **202**.

[0132] In the above one aspect, once the LED intensities are set by the light source control unit **230** in coordination with the detector gains of the light detectors **222/224** set by the light detector control unit **232** over the first **10** detection cycles, an additional **10** detection cycles are obtained to confirm the suitability of these settings for operation of the system **200** given the tissue properties of the particular patient **202**, followed by a recalculation of the LED intensity settings and detector gains as described herein. If the newly calculated LED intensity is within a factor of two of the previously determined setting, and the detector gains are not changed, the previously determined settings are maintained for subsequent data acquisition cycles used to determine renal function. Otherwise, the settings are updated using the same method described herein and another **10** data acquisition cycles conducted to confirm the stability of the settings. This process repeats until either the settings are determined to be acceptably stable or **10** data acquisition cycles are

conducted to obtain the settings, in which case the most recently determined settings are used for all subsequent data acquisitions, and the user may be notified via the display unit **216** that the settings may not be optimal.

#### ii) Light Detector Control Unit

[0133] Referring again to FIG. **2**, the controller **212** may include a light detector control unit **232** configured to operate the first light detector **222** and the second light detector **224** to enable the detection of light at the emission wavelength and unfiltered light at all wavelengths, respectively. In various aspects, the light detector control unit **232** may produce a plurality of detector control signals encoding one or more detector control parameters including, but not limited to, detector gains. In various other aspects, the light detector control unit **232** may produce a plurality of light measurement signals encoding the intensity of light detected by the light detectors **222/224** including, but not limited to raw detector signals that may be received by an analog-to-digital convertor (ADC) **1102** (see FIG. **11**) in various aspects. In another aspect, the detector gains and/or other detector control signals may be manually set by a user detector gains when the system **200** is configured in an Engineering Mode.

[0134] In various other aspects, the amount of light received by the light detectors **222/224** may vary due to any one or more of at least several factors including, but not limited to: variation in skin tones observed between individual patients **202**, variations in the concentrations of exogenous fluorescent agent within each patient **202**, and any other relevant parameter. In one aspect, gains of the first light detector **222** and the second light detector **224** may be set by a user via the operation unit **214**. In another aspect, the light detector control unit **232** may be configured to modulate the gain of the light detectors **222/224** automatically via a bias voltage gain of the bias voltage generator **1112** (see FIG. **11**).

[0135] In one aspect, signals obtained during the first **10** detection cycles obtained by the system **200** after initialization of data acquisition, but prior to the injection of the exogenous fluorescent agent, may be used by the light detector control unit **232** to automatically adjust the gains of the light detectors **222/224**, as well as the output intensities of the light sources **218/220**. As described herein previously, the initial detection cycle may be obtained with the LED light sources **218/220** set at about 10% of maximum LED intensity (corresponding to a normalized output intensity of 0.1) and with a low gain setting for the light detectors **222/224** and the LED intensities may be modulated to enable the analog signals produced by the light detectors **222/224** to correspond to about  $\frac{1}{4}$  of the full range of each detector analog-to-digital convertor (ADC) at the low detector gain setting.

[0136] In this one aspect, if the intensity of the first LED light source **218** (producing light at the excitation wavelength) is set to the maximum of the LED power range, a high detector gain may be considered for the second light detector **224** corresponding to the filtered measurements of the excitation wavelength only. In various aspects, the high detector gain may be 10-fold higher than the corresponding low detector gain for a given light detector. Without being limited to any particular theory, the expected peak detected fluorescence signal from the exogenous fluorescence agent over the course of injection and renal elimination is typically

expected to be about 10% of the magnitude of the signal received during illumination at the excitation wavelength by the first light source 218, assuming that the exogenous fluorescence agent is MB-102 introduced into the patient 202 at a dose level of about 4  $\mu\text{mol/kg}$  of patient weight. In an aspect, if the expected detector signal received during illumination at maximum LED intensity and with the detector gain set to the high setting remains below 10% of the range of the detector ADC, the detector gain for that measurement be increased by ten-fold. In another aspect, the saturation condition may persist for a pre-defined period of time including, but not limited to, a 30-second period before adjustments are made to the detector gain or LED power to avoid reacting to spurious signal spikes.

[0137] In another aspect, the light detector control unit 232 may adjust the detector gain to a lower gain level if the detected light signals from one of the light detectors 222/224 exceed a threshold percentage of the maximum ADC range to avoid signal saturation. Although the highest threshold percentage of the maximum ADC range associated with signal saturation is 100%, the onset of severe detector non-linearity takes place at threshold percentages of about 40% or more, and mild detector non-linearity occurs at threshold percentages in excess of about 15%. In various aspects, the threshold percentage of the maximum ADC range may be 40%, 35%, 30%, 25%, 20%, 18%, 17%, 16%, 15%, 14%, 13%, 12%, 11%, 10%, 9%, 8%, 7%, 6%, or 5% of the maximum ADC range. In one aspect, if the detected light signals from one of the light detectors 222/224 exceed about 8% of the maximum ADC range, the gain setting will be adjusted. By way of non-limiting example, if the detector gain on the nearly saturated signal is high, it will be adjusted to low. If the current detector gain is set to low and the corresponding detected light signal remains above the threshold percentage of the maximum ADC range, the LED output power setting of the corresponding LED light source may be reduced ten-fold.

[0138] In an aspect, the light detector control unit 232 may receive one or more feedback measurements used to modulate the plurality of detector signals to compensate for variations in the performance of the light detectors due to variations in temperature and/or light source output. Non-limiting examples of feedback measurements used by the light detector control unit 232 include: light output of the light sources 218/220 measured within the source well 902 by the first monitor photodiode 904 and the second monitor photodiode 906, respectively (see FIG. 11), temperatures of the light detectors 222/224 measured by a first temperature sensor 1106, LED temperatures measured by a second temperature sensor 1108, temperature of the sensor head housing measured by a third temperature sensor 1128, LED supply current from the LED current source 1126, and any other feedback measurement relevant to monitoring the performance of light detectors 222/224.

[0139] In various aspects, the light detectors 222/224 may be silicon photon multiplier (SPM) detectors that may include low-noise internal amplification, and may function at lower light levels relative to other light sensor devices such as PIN photodiodes. The detector signal generated by the SPM detectors 222/224 may be amplified using transimpedance amplifiers 1120/1118, respectively (see FIG. 11) to translate a current generated by each SPM light detector 222/224 into a measurable detector voltage. The transimpedance amplifier 1118 on the second SPM light detector

224 (i.e. detects filtered lights at the excitation wavelength only) may include a switchable detector gain that may select a low gain configured to detect a larger dynamic range for fluorescence measurements when the first LED light source 218 is activated to produce light at the emission wavelength. The switchable detector gain that may further select a high gain setting for the second SPM light detector 224 when the second light source 220 is inactive to enhance the sensitivity of the second SPM light detector 224 during the phase of the detection cycle when light at the emission wavelength produced by the exogenous fluorescent agent within the tissues of the patient 202 is detected, to ensure that the expected dark current from the second SPM light detector 224 occupies less than  $\frac{1}{4}$  of the total ADC output range. In one aspect, the second transimpedance amplifier of the second SPM light detector 224 may include a low detector gain configured to provide a transimpedance gain of about 4 k $\Omega$  corresponding to about twice the value of the transimpedance resistor due to differential operation, and may further include a high detector gain configured to provide a transimpedance gain of about 40 k $\Omega$ . In another aspect, the first transimpedance amplifier of the first SPM light detector 222 may include a fixed detector gain configured to provide a transimpedance gain of about 2 k $\Omega$ .

### iii) Acquisition Unit

[0140] Referring again to FIG. 2, the controller 212 may further include an acquisition unit 234 in various aspects. The acquisition unit 234 may be configured to receive a plurality of signals from the light sources 218/220, light detectors 222/224, and additional light detectors 226 and additional temperature sensors 228 and processing the plurality of signals to produce one or more raw signals including, but not limited to, raw fluorescence signals encoding the intensity of fluorescence detected by the second light detector 224 during illumination at the excitation wavelength, and raw internal reflectance signals corresponding to the intensity of light at the excitation wavelength detected by the first light detector 222 during illumination at the excitation wavelength as well as the intensity of light at the emission wavelength detected by the both light detectors 222/224 during illumination at the emission wavelength.

[0141] The plurality of signals received from the various sensors and devices described herein above are typically analog signals including, but not limited to, electrical voltages and currents. In various aspects, the acquisition unit 234 may enable the transmission of the analog signals to one or more analog-to-digital converters (ADCs) to convert the analog signals into digital signals for subsequent processing by the processing unit 236. FIG. 11 is a schematic diagram of a circuit 1100 illustrating the arrangement of various electrical devices and components of the sensor head 204. In one aspect, the analog signals encoding the intensity of light detected by the first light detector 222 and the second light detector 224 may be received by a first ADC 1102.

[0142] In various aspects, the analog signals produced by the light detectors 222/224 and various monitor sensors may be digitized using at least one 24-bit Sigma-Delta ADC. Referring again to FIG. 11, analog signals encoding the measurements from time-sensitive sensors may be digitized using a high-speed 24-bit Sigma-Delta ADC 1102 in one aspect. In this aspect, time-sensitive sensors include sensors associated with the production and detection of light pulses characterized by potentially rapidly-changing signals. Non-limiting examples of time-sensitive sensors of the system

**200** include: first and second light detectors **1118/1120**, and first and second monitor photodiodes **904/906**. In another aspect, analog signals encoding the measurements from less time-sensitive sensors may be digitized using a low-speed 24-bit Sigma-Delta ADC **1104**. In this other aspect, the less time-sensitive sensors include sensors associated with monitoring system conditions characterized by typically slow-changing signals including, but not limited to, temperatures of various system components and/or regions. Non-limiting examples of less time-sensitive sensors of the system **200** include: a first and second thermistor **1106/1108** configured to monitor the temperatures of the light sensors **222/224** and light sources **218/220**, respectively, and a third temperature sensor **1128** configured to monitor a temperature of the housing **600** of the sensor head **204**.

[0143] In various aspects, the acquisition unit **234** may be further configured to enable synchronous detection of light by detectors **222/224**. Without being limited to any particular theory, synchronous detection methods are thought to reject noise from the detector signals associated with the detection of light produced by the light sources **118/120** and fluorescence produced by the exogenous fluorescent agents within the tissues of the patient **202** by distinguishing the detector signals from noise associated with the detection of ambient light or other sources of interference.

[0144] FIG. 12 is a schematic illustration of a synchronous detection method in one aspect. Referring to FIG. 11 and FIG. 12, the waveform generator/FPA **1122** may generate a digital square wave **1202** that is received by the DAC **1124**, and the resulting analog-converted square wave is received by the LED current source **1126**. The resulting current produced by the LED current source **1126**, also characterized by a waveform proportional to the analog-converted square wave drives LED light sources **218/220**. The light produced by LED light sources **218/220**, after passing through the tissues of the patient **202** are detected, along with the fluorescence produced by the endogenous fluorescent agent, by the light detectors **222/224** and are digitized by the high-speed ADC **1102**.

[0145] Referring again to FIG. 11 and FIG. 12, the digital square wave **1202** generated by the waveform generator/FPA **1122** may also be converted by a DAC **1110** (see FIG. 11) to an in-phase reference sine wave **1210** and an out-of-phase/quadrature reference cosine wave **1212**. In an aspect, the digitized detector signals from the ADC **1102** and the in-phase reference sine wave **1210** may be sampled and subjected to signed multiplication at a first multiplier **1214** to generate a plurality of in-phase modulated signals. In addition, the digitized detector signals and the quadrature reference cosine wave **1212** may be sampled and subjected to signed multiplication at a second multiplier **1216** to generate a plurality of quadrature (out-of-phase) modulated signals. In this aspect, the acquisition unit **234** may delay the samples from the reference waves **1210/1214** by an amount equivalent to the relative delay between the DAC **1124** generating the reference waves **1210/1214** and the ADC **1102** digitizing the detector signals to synchronize the reference waves **1210/1214** to the detector data being acquired.

[0146] Referring again to FIG. 12, the in-phase modulated signals may be summed in a first accumulator **1218** to generate an in-phase intensity signal **1224**. Similarly, the quadrature modulated signals may be summed in a third accumulator **1222** to generate a quadrature intensity signal

**1228**. The raw digitized detector signal may also be summed in a second accumulator **1220** to generate an average intensity signal **1226**. In addition, the in-phase intensity signal **1224** and the quadrature intensity signal **1228** may be root-sum squared to generate a magnitude signal **1230**.

[0147] Without being limited to any particular theory, the integration interval of the accumulators **1218/1220/1222** may correspond to an integer number of modulation cycles (corresponding to cycles of the digital square wave **1202**) to avoid a bias on the measured signal. The phase accumulators **1218/1220/1222** used to control the synchronous detection operates on integer numbers, but the sample clock frequency and the modulation frequency are not integer-divisible, so the number of cycles is not exactly an integer. However, the error associated with this mismatch may be minimized by adjusting the actual modulation frequency to match as closely as possible with the achievable sampling intervals and allocating an appropriate number of bits to the phase accumulator. In one aspect, the error associated with the mismatch between the modulation frequency and the sampling intervals may be on the order of about one part in **106**.

[0148] In one aspect, the digital square wave **1202** used to modulate the LED light sources **218/220** and to enable synchronous detection method as described herein above is produced at a frequency of about 1 kHz. Without being limited to any particular theory, a square wave was selected as the modulating waveform to enable an enhancement in signal to noise ratio (SNR), as compared to a pure sinusoidal wave as the modulating waveform for the same peak power level.

[0149] In another aspect, the acquisition unit **234** may be further configured to enable demodulation of the in-phase intensity signal **1224**, average intensity signal **1226**, and quadrature intensity signal **1228**. In one aspect, the acquisition unit **234** may pick out each component at the fundamental harmonic, which is characterized by an amplitude that is  $(4/\pi)$  times larger than the amplitude of the square wave **1202** used to modulate the intensity signals **1224/1226/1228**. In various aspects, to reject 50/60 Hz electrical noise generated by the alternating current electrical power sources, and corresponding 100/120 Hz optical noise generated by ambient light sources powered from those electrical power sources, the integration period of the accumulators **1218/1220/1222** may be selected to be a multiple of 100 ms. In these various aspects, this selected integration period ensures that integration by the accumulators **1218/1220/1222** occurs over an integer number of cycles for the 50, 60, 100, and 120 Hz signals.

#### iv) Processing Unit

[0150] Referring again to FIG. 2, the controller **212** may further include a processing unit **236** configured to apply corrections to the demodulated detector signals and to transform a selected portion of the corrected detector signals into a measure of renal function in various aspects. FIG. 13 is a block diagram illustrating the subunits of processing unit **236** in an aspect. Referring to FIG. 13, the processing unit **236** may include a pre-processing subunit **1302** configured to determine and correct the detector signals to remove signal artifacts associated with a variety of confounding effects including, but not limited to, physiologically-induced signal variations, variations in power supplied to the light sources **218/220**, non-linearities in detector response, ambient temperature variation, and tissue heterogeneity. The

processing unit **236** may further include a baseline subtraction subunit **1304** configured to remove the portion of the detector signals attributable to extraneous factors such as autofluorescence of the tissues and/or leakage of light at the excitation wavelength through the optical filter **244** of the second light detector **224**. The processing unit **236** may additionally include a diffuse reflectance correction subunit **1306** configured to enable a method of applying a diffuse reflectance correction method to remove the effects of the diffuse reflectance of light within the tissues of the patient **202**. The processing unit **236** may further include a post-equilibrium selection subunit **1308** configured to select a portion of the detector data associated with the post-agent administration period for subsequent analysis to determine renal function of the patient. The processing unit **236** may further include an RDTC calculation subunit **1310** configured to transform the detector signals obtained over the post-agent administration period to produce a renal decay time constant indicative of the renal function of the patient. The processing unit **236** may also include a fault detection subunit **1312** configured to monitor the magnitudes of the detector signals to detect any malfunctions of the system.

#### a) Pre-Processing Subunit

[0151] In one aspect, the raw signals corresponding to the light intensity detected by light detectors **222/224** corresponding to illumination by the first light source **218** and the second light source **220** at the excitation and emission wavelength, respectively, are pre-processed using various modules of the pre-processing subunit **1302** to remove the effects of a plurality of confounding factors from the raw signals, resulting in signals that more accurately reflect the underlying specific signals of interest.

[0152] By way of several non-limiting examples, the intensity of light produced by a light source may vary due to one or more of a plurality of factors including, but not limited to: fluctuations in the electrical current supplied to the light source and variations in the ambient temperature of the light source. Light characterized by two or more wavelengths emanating from the same source aperture of the sensor head may not share the same path to the same detector. The detectors may have thermally-dependent sensitivity and gain. Further, the optical filter associated with the second light detector **224** may have temperature-dependent transmission properties.

[0153] In one aspect, the pre-processing subunit **1302** is configured to process the raw signals corresponding to light intensities detected by the first and second light detectors **222/224** in order to remove one or more of the measurement errors associated with the devices and elements of the system **200** and patient-specific factors including, but not limited to, the plurality of factors described above. FIG. **22A** is a block diagram illustrating the modules of the pre-processing subunit **1302** in one aspect. FIG. **22B** is a block diagram illustrating the modules of the pre-processing subunit **1302a** in a second aspect.

[0154] In one aspect, illustrated in FIG. **22A**, the pre-processing subunit **1302** 1) resamples the signals using the methods of the resampling module **2202** as described below, 2) removes saturated detector signals using the methods of the detector output saturation detection and removal module **2204** as described below, 3) corrects for temperature-dependent detector gain using the methods of the detector temperature correction module **2206** described below, 4) cor-

rects the signals for instrument light directionality using the methods of the light directionality correction module **2208** described below, 5) corrects the signals for filter throughput and temperature-dependent variation of fluorescence light using the methods of the filter throughput temperature correction (emission) module **2212** described below, 6) corrects for tissue heterogeneity using the methods of the tissue heterogeneity correction module **2216** described below, 7) corrects the signals for filter throughput and temperature-dependent variation of excitation light and signal decomposition using the methods of the filter throughput temperature correction (excitation) module and signal decomposition module **2214** as described below, 8) corrects for optical power variation using the methods of the fractional photon normalization module **2218** as described below.

[0155] In one aspect, illustrated in FIG. **22B**, the pre-processing subunit **1302a** calculates signal magnitudes using the methods of the detector temperature correction module **2206a** as described below, resamples the signals using the methods of the resampling module **2202a** as described below, removes saturated samples using the methods of the detector output saturation detection and removal module **2204a** as described below, corrects the signals for temperature-dependent detector gain using the methods of the detector temperature correction module **2206a** described below, corrects the signals for optical power variation using the methods of the fractional photon normalization module **2218a** as described below, corrects for excitation light leakthrough onto the measured fluorescence signal using the filter throughput temperature correction (excitation) module and signal decomposition module **2214a** as described below, and corrects for fluorescence light leakthrough onto the measured excitation diffuse reflectance signal using the filter throughput temperature correction (emission) module **2212a** as described below.

#### Resampling Module

[0156] Referring to FIG. **22A** and FIG. **22B** the pre-processing subunit **1302/1302a** in various aspects includes a resampling module **2202/2202a** configured to reduce signal variations associated with physiological processes of the patient **202** including, but not limited to, heartbeat and breathing. Typically, an acquisition sequence is characterized by alternating interval of illumination at the excitation and emission separated by intervals of no illumination (i.e. dark intervals). Although both illumination intervals (excitation/emission) are time-stamped with the same time-stamp value as described above, the dark interval between the excitation and emission illumination intervals results in a separation interval between the excitation and emission illumination intervals. Without being limited to any particular theory, if the separation interval associated with an acquisition sequence is on the order of a separation interval between physiological events, such as heartbeats or respiration, physiological noise may be introduced to the signals. In various aspects, this physiological noise may be reduced by resampling the signals associated with the excitation and emission illumination to overlap prior to subsequent processing of the signals.

[0157] By way of non-limiting example, a sample sequence may include a 100 ms dark interval, a 100 ms interval of illumination at the excitatory wavelength, a second 100 ms dark interval, and a 100 ms interval of



illumination at the emission wavelength. Each sample packet is logged with a single timestamp, and each sample packet is separated by a 400 ms interval. Because physiological signal variations, such as from heartbeats, occur on this same timescale, the 200 ms difference between signal acquisition associated with the excitatory and emission wavelengths becomes apparent in the signals. This physiological signal noise may be reduced using the pre-processing subunit **1302** by first resampling the signals associated with illumination at the excitatory and emission wavelength illumination to overlap prior to performing any additional signal processing as described below. In this non-limiting example, the signals associated with illumination at the excitatory wavelength may be shifted forward by 100 ms and the signals associated with illumination at the emission wavelength may be shifted backwards by 100 ms, resulting in an overlap of the signals.

[0158] In various aspects, the resampling module **2202** performs resampling as described above on signals detected by both the first and second detectors **222/224**. In one aspect, the resampling module **2202** functions as a form of low-pass filter.

#### Detector Output Saturation Detection and Removal Module

[0159] Referring again to FIG. **22A** and FIG. **22B** the pre-processing subunit **1302/1302a** in various aspects includes a detector output saturation detection and removal module **2204/2204a** configured to detect and remove signal values that fall outside the detection range of the light detectors **222/224**. In one aspect, the pre-processing subunit **1302** compares the detected signals to the maximum ADC signal. If any signal falls within a threshold range of the maximum ADC signal using the average or peak signal value, the detector output saturation detection and removal module **2204** identifies and removes that value from further processing.

#### Detector Temperature Correction Module

[0160] FIG. **22A** and FIG. **22B** the pre-processing subunit **1302/1302a** in various aspects includes a detector temperature correction module **2206/2206a** configured to enable a temperature correction to compensate for the thermal sensitivity of the light detectors **222/224**. In one aspect, the intrinsic detector gain for a silicon photomultiplier (SPM) device typically used as a light detector is proportional to the difference between the device breakdown voltage and the bias voltage applied by the bias voltage generator **1112** (see FIG. **11**), referred to herein as an overvoltage. In this aspect, the breakdown voltage varies with temperature in a well-characterized manner. In one aspect, the temperature correction accounts for both this internal detector gain variation and additionally temperature-related variation in the photon detection efficiency.

[0161] In one aspect, the temperature correction may be a scaling correction applied to the detector measurements in which the scaling correction is based on a measured detector temperature. In an aspect, the measured light detector signals may be divided by the calculated gain  $G(t)$  to remove the temperature dependency. The scaling correction  $G(t)$  may be calculated according to Eqn. (2):

$$G(T) = C_v \cdot V_{bias} - V_{breakdown}(1 + C_T)^{T-T_0} \quad \text{Eqn. (2)}$$

[0162] In Eqn. (2), the monitor temperature  $T$  is obtained from a first temperature sensor **1106** (see FIG. **11**) configured to monitor the temperature of the sensors **222/224**. The bias voltage ( $V_{bias}$ ) may be measured by the bias voltage generator **1112**. The breakdown voltage ( $V_{breakdown}$ ) and reference temperature ( $T_0$ ) are constants specific to the particular light detector device included in the system **200**. By way of non-limiting example, if the light detectors **222/224** are silicon photomultiplier (SPM) devices,  $V_{breakdown}$  may be 24.5 V and  $T_0$  may be 21 degrees C. In another aspect, the coefficients  $C_v$  and  $C_T$  used in Eqn. (2) may be derived empirically based on measurements obtained using a constant phantom over an ambient temperature ranging from about 18 degrees C. to about 26 degrees C.

[0163] In another aspect, the temperature portion of the gain correction is determined by the Eqns. (3)-(5).

$$G_{useCase} = C_v \cdot V_{bias_{measured}} - V_{breakdown}(1 + C_T)^{T_{measured}-T_0} \quad \text{Eqn. (3)}$$

$$G_{nominal} = C_v \cdot V_{bias_{nominal}} - V_{breakdown}(1 + C_T)^{T_{nominal}-T_0} \quad \text{Eqn. (4)}$$

$$G_{correction} = \frac{G_{useCase}}{G_{nominal}} \quad \text{Eqn. (5)}$$

[0164] This gain correction can be applied to each of the signal magnitudes as measured by the first and second light detectors **222/224** as follows:

$$SPM_{magnitude}_{corrected} = \frac{SPM_{magnitude}}{G_{correction}} \quad \text{Eqn. (6)}$$

[0165] In an aspect, the magnitudes of the temperature-corrected measurements from each detector and monitor photodiode are calculated from the root sum-squares of the in-phase intensity signals **1224** (I) and quadrature intensity signals **1228** (Q) according to Eqn. (1):

$$M = \sqrt{I^2 + Q^2} \quad \text{Eqn. (1)}$$

[0166] The signal magnitudes from the light detectors **222/224** calculated using Eqn. (1) are normalized by the monitor photodiode magnitude for each measurement set corresponding to the measurements obtained during illumination by one of the LED light sources **218/220** at either the excitation or emission wavelength. In one aspect, if one photodiode is positioned in the source well **902**, the single photodiode magnitude from the corresponding measurement set is used for this normalization. In another aspect, if two monitor photodiodes **904/906** are positioned in the same source well **902** as both LED light sources **218/220** (see FIG. **9**), the average of the two monitor photodiode magnitudes from the corresponding measurement set is used for this normalization.

[0167] In an aspect, the in-phase intensity signal **1224**, quadrature intensity signal **1228**, and average intensity signal **1226** (see FIG. **12**) are further processed for the number

of accumulated samples and ADC scaling such that the intensity signals **1224/1226/1228** are returned as fraction of the full range of the high-speed ADC **1102** (i.e. ranging from a minimum of 0 to a maximum of 1). The measurements of the monitor photodiodes **904/906** (see FIG. **11**) are similarly scaled as a fraction of the full range of the low-speed ADC **1104**.

[**0168**] In one aspect,  $G_{correction}$  may incorporate a power correction to correct for the effects of fluctuations in the LED power supply. In this aspect, the signals from the first monitor photodiode **904** and the second monitor photodiode **906** are calibrated by measuring optical output power with a power meter as light intensities from the light sources **218/220** are varied. The calibration coefficients for each light source **218/220**,  $C_{source1}$  and  $C_{source2}$ , are calculated as detector-measured milliWatts per recorded monitor photodiode signal value.  $C_{source1}$  and  $C_{source2}$  are used to determine the absolute light output into tissue at each wavelength. [**0169**] Referring again to FIG. **22B**, the detector temperature correction module **2206a** corrects signal magnitudes for the varying intensity of the LEDs by normalizing the temperature-corrected detected signals using the LED output signal  $PD_{magnitude}$  measured by the first monitor photodiode **904** and/or the second monitor photodiode **906**. In this case, the  $G_{correction}$  variable for each light source **218/220** from above is amended as follows:

$$G_{correction} = \frac{G_{useCase}}{G_{nominal}} * PD_{magnitude} \quad \text{Eqn. (7)}$$

#### Light Directionality Correction Module

[**0170**] Referring again to FIG. **22A**, the pre-processing subunit **1302** in this aspect includes a light directionality correction module **2208** configured to enable a correction to variations in the detected signals associated with differences in the scattering and absorption of light of different wavelengths through the tissues of the patient **202** during data acquisition. In one aspect, a correction term for light directionality may be measured by acquiring data from one or more homogeneous tissue phantoms and using a sensor configuration in which no emission filters are present. The ratio of the signals detected by the first light detector **222** (Det1) and the signals detected by the second light detector **224** (Det2) measured are used to determine a coefficient  $G_{ex}$  or  $G_{em}$  for signals obtained in association with illumination by light at the excitation and emission wavelengths, respectively. The coefficients are used to modify the signal detected by the first light detector **222**. In one aspect, the correction of the signals acquired in a homogeneous medium by the first light detector **222** using the coefficients  $G_{ex}$  or  $G_{em}$  render the signals measured by the first and second detectors **222/224**, as equivalent to within 20% of one another. In other aspects, the correction of the signals acquired in a homogeneous medium by the first light detector **222** using the coefficients  $G_{ex}$  or  $G_{em}$  render the signals measured by the first and second detectors **222/224** as equivalent to within about 10%, to within about 5%, to within about 2%, and to within about 1%.

#### Detector Non-Linear Response Correction Module

[**0171**] Referring again to FIG. **22A**, the pre-processing subunit **1302** in this aspect includes a detector non-linear

response correction module **2210** configured to enable a correction to variations in the detected signals associated with non-linear response of the detectors. In this aspect, a calibration curve based on average data may be used to scale the magnitude data obtained by the detectors **222/224**.

#### Filter Throughput Temperature Correction (Emission) Module

[**0172**] Referring again to FIG. **22A**, the pre-processing subunit **1302** in this aspect includes a filter throughput temperature correction (emission) module **2212** configured to enable a correction to variations in the detected signals associated with temperature-dependent optical properties of the optical filter **244** associated with the second light detector **224** during emission-wavelength illumination. In this aspect, the signals Det2 detected by the second light detector **224** may be corrected according to Eqn. (8):

$$Det2 = \frac{Det2 - Det2(C_{emF,slopeT}(T-T_{nom}))}{C_{emF,nom}} \quad \text{Eqn. (8)}$$

[**0173**] In various aspects, the signal Det2 measured by the second light detector **224** may be monitored while ambient temperature is cycled over a range including the operating temperature range or a large enough subset of the range to adequately determine the temperature-dependence of the emission filter. These data are acquired with the optical filter **244** installed on the second light detector **224** from a homogeneous, non-fluorescent phantom. Further, simultaneous measurements are monitored from the first light detector **222**, and a ratio of the measurements Det2/Det1 is determined. The nominal filter coefficient,  $C_{emF,nom}$  is calculated as the nominal ratio of Det2/Det1 obtained at a nominal operating temperature  $T_{nom}$ . In this aspect, the coefficient  $C_{emF,slopeT}$  is obtained from the slope of Det2/Det1 obtained over a range of ambient temperatures during emission-wavelength illumination of the homogeneous, non-fluorescent phantom.

#### Tissue Heterogeneity Correction Module

[**0174**] Referring again to FIG. **22A**, the pre-processing subunit **1302** in this aspect includes a tissue heterogeneity correction module **2216** configured to enable a correction to variations in the detected signals associated with heterogeneity of the tissues intervening between the first region **206** illuminated by light sources **218/220** and the second and third regions **208/210** at which the light detectors **222/224** are positioned. In this aspect, the signal Det1 corrected for light directionality by the light directionality correction module **2208** and the signal Det2 corrected for filter effects by the filter throughput temperature correction (emission) module **2212** are used to calculate  $C_{hetero}$ , a coefficient to correct for tissue heterogeneity, according to Eqn. (9):

$$C_{hetero} = Det2/Det1 \quad \text{Eqn. (9)}$$

#### Filter Throughput Temperature Correction (Excitation) and Signal Decomposition Module

[**0175**] Referring again to FIG. **22A**, the pre-processing subunit **1302** in this aspect includes a filter throughput

temperature correction (excitation) module and signal decomposition module **2214** configured to enable a correction to variations in the detected signals associated with temperature-dependent optical properties of the optical filter **244** associated with the second light detector **224** during excitation-wavelength illumination. In this aspect, because the emission filter is configured to block light at the excitation wavelength, the filter throughput temperature correction (excitation) module and signal decomposition module **2214** performs a correction to variance to the amount of excitation light leakthrough due to temperature-related changes in the optical properties of the optical filter **244**. Further, the filter throughput temperature correction (excitation) module and signal decomposition module **2214** enables corrections of the signals measured by the first light detector **222** during excitation-wavelength illumination due to the presence of fluorescence induced by the excitation-wavelength illumination superimposed over the portion of the signal associated with the excitation-wavelength illumination.

[0176] In this aspect, the effects of temperature-dependent variation on leakthrough of excitation-wavelength by the optical filter **244** are calculated as expressed in Eqn. (10):

$$C_{exLT} = C_{exLT,nom} + C_{exLT,slopeT}(T - T_{nom}) \quad \text{Eqn. (10)}$$

[0177] In this aspect,  $C_{exLT,nom}$  is calculated from the ratio of signals Det1 and Det2 measured from a homogeneous, non-fluorescent phantom at the nominal operating temperature  $T_{nom}$  during excitation-wavelength illumination.  $C_{exLT,slopeT}$  is calculated as the slope of the signal Det2 measured from a homogeneous, non-fluorescent phantom at a range of operating temperatures T during excitation-wavelength illumination.

[0178] In this aspect, the filter throughput temperature correction (excitation) module and signal decomposition module **2214** further performs a signal extraction to isolate portions of the detected signals associated with diffuse reflectance of the excitation-wavelength illumination and fluorescence.  $DR_{ex2}$ , which is the amount of excitation light impinging on the second light detector **224** in the absence of an optical filter **244**, is not measurable, due to the presence of the optical filter **244**. Further, the signal Det1 measured by the first light detector **222** is a composite signal from both diffuse reflectance of the excitation-wavelength illumination  $DR_{ex1}$  and fluorescence  $Flr1$ .  $C_{Hetero}$  is obtained using the tissue heterogeneity correction module **2216** as described above. The underlying signals are extracted by use of the following system of equations:

$$Det_2 = C_{exLT}DR_{ex2} + Flr_2 \quad \text{Eqn. (11)}$$

$$Det_1 = DR_{ex1} + Flr_1 \quad \text{Eqn. (12)}$$

$$Flr_2 = C_{Hetero}Flr_1 \quad \text{Eqn. (13)}$$

$$DR_{ex2} = C_{Hetero}DR_{ex1} \quad \text{Eqn. (14)}$$

[0179] In this aspect,  $Flr_2$  is determined by solving the above system of equations using only measurable signals Det1 and Det2 as demonstrated below:

$$Det_2 = C_{exLT}C_{Hetero}DR_{ex1} + Flr_2 \quad \text{Eqn. (15)}$$

$$Det_2 = C_{exLT}C_{Hetero}(Det_1 - Flr_1) + Flr_2 \quad \text{Eqn. (16)}$$

$$Det_2 = C_{exLT}C_{Hetero}Det_1 - C_{exLT}C_{Hetero}Flr_1 + Flr_2 \quad \text{Eqn. (17)}$$

$$Det_2 - C_{exLT}C_{Hetero}Det_1 = Flr_2(1 - C_{exLT}) \quad \text{Eqn. (18)}$$

$$Flr_2 = \frac{Det_2 - C_{exLT}C_{Hetero}Det_1}{1 - C_{exLT}} \quad \text{Eqn. (19)}$$

[0180] In this aspect, once  $Flr_2$  is obtained as described above, the other signals  $Flr_1$ ,  $DR_{ex1}$ , and  $DR_{ex2}$  may be readily obtained through insertion into the system of equations (Eqns. (11)-(14)) presented above.

#### Fractional Photon Normalization Module

[0181] Referring again to FIG. 22A, the pre-processing subunit **1302** in this aspect includes a fractional photon normalization module **2218** configured to convert the detector signals, after preprocessing as described above, into units of fractional photons for use in subsequent background subtraction and intrinsic fluorescence correction algorithms as described herein. In this aspect, the detector signals may be converted to photocurrent by reversing the scaling associated with the ADC and the transimpedance amplifier used to acquire the detected signals to obtain the signals in units of photocurrents. Once photocurrent is obtained, a detector responsivity supplied by the light detector's manufacturer is used to convert the detector photocurrents to units of Watts. The detector signals in Watts are then ratioed to the source power in Watts as measured by additional light detectors **226** used to monitor the output of the light sources **218/220** to obtain the number of fractional photons detected.

#### Optical Power Correction Module

[0182] Referring again to FIG. 22A and FIG. 22B, the pre-processing subunit **1302/1302a** in this aspect includes a fractional photon normalization module **2218/2218a** configured to convert the detector signals, after preprocessing as described above, into units of fractional photons for use in subsequent background subtraction and intrinsic fluorescence correction algorithms as described herein. In this aspect, the detector signals may be converted to photocurrent by reversing the scaling associated with the ADC and the transimpedance amplifier used to acquire the detected signals to obtain the signals in units of photocurrents. Once photocurrent is obtained, a detector responsivity supplied by the light detector's manufacturer is used to convert the detector photocurrents to units of Watts. The detector signals in Watts are then ratioed to the source power in Watts as measured by additional light detectors **226** used to monitor the output of the light sources **218/220** to obtain the number of fractional photons detected.

#### Excitation Light Leakthrough Subtraction Module

[0183] Referring again to FIG. 22B, the pre-processing subunit **1302a** in this aspect includes an excitation light leakthrough subtraction module **2222** configured to perform an excitation leakthrough subtraction on the  $Flr_{meas}$  signal. To arrive at a fluorescence signal due only to fluorescent photons ( $Flr_{photons}$ ), an excitation leakthrough subtraction is performed. To remove the contribution of excitation light, the excitation leakthrough is taken to be a fraction of the

diffuse reflectance excitation ( $DR_{ex_{meas}}$ ) signal, where a universal calibration factor,  $C_{ExLT}$ , determines the fraction of the signal to subtract from  $Flr_{meas}$  as expressed below:

$$ExLT = C_{ExLT} * DR_{ex_{meas}}$$

where  $C_{ExLT}$  is a calibration factor that is obtained by computing the ratio between the excitation light detected by both detectors on a non-fluorescing optical phantom as described below:

$$C_{ExLT} = \frac{Flr_{meas}}{DR_{ex_{meas}}}$$

[0184] This signal is then subtracted from  $Flr_{meas}$  to provide a fluorescence signal due only to fluorescent photons as expressed below:

$$Flr_{photons} = Flr_{meas} - ExLT$$

#### Fluorescence Light Leakthrough Subtraction Module

[0185] Referring again to FIG. 22B, the pre-processing subunit **1302a** in this aspect includes a fluorescence light leakthrough subtraction module **2224a** configured to perform a fluorescence leakthrough subtraction on the  $Flr_{meas}$  signal. To obtain the diffuse reflectance, defined herein as the excitation signal due to only excitation photons ( $DR_{ex_{photons}}$ ), a fluorescence leakthrough subtraction is performed. To remove the fluorescence leakthrough, a calibration factor,  $C_{FlrLT}$ , was determined based on the relationship between the amount of fluorescence leakthrough observed on a database of human subject data and tissue heterogeneity as measured by the relationship between the diffuse reflectance, emission signals ( $DR_{emFilt}/DR_{em}$ ). The relationship is a linear relation as expressed below:

$$C_{FlrLT} = p1 * \left( \frac{DR_{em}}{DR_{emFilt}} \right) + p2$$

where  $p1$  and  $p2$  are approximately 0.61 and 0.01, respectively, in one aspect, as determined by the above-mentioned relationship. In another aspect,  $p1$  and  $p2$  may assume any other value without limitation as defined by the above relationship.

[0186] The  $DR_{ex_{photons}}$  signal is then calculated by subtracting this fraction of measured fluorescence from the diffuse reflectance excitation signal, as follows:

$$DR_{ex_{photons}} = DR_{ex_{meas}} - Flr_{meas} * C_{FlrLT}$$

#### b) Baseline Subtraction Subunit

[0187] Referring again to FIG. 13, the processing unit **236** further includes a baseline subtraction subunit **1304**. In an

aspect, the baseline subtraction subunit **1304** subtracts a baseline signal from the light detector measurements to correct for the effects of autofluorescence and light leakage. The baseline period, as used herein, refers to an initial time period of measurements obtained prior to injection of the exogenous fluorescent agent. During the baseline period, the fluorescence signal measured by the system **200** may be assumed to associated with tissue autofluorescence and/or excitation light from the LED light sources **218/220** leaking through the absorption filter **244** of the second light detector **224**. In an aspect, the average signal measured during the baseline period, referred to herein as a baseline signal, may be subtracted from subsequent fluorescence measurements to yield a measurement associated solely with the fluorescence produced by the exogenous fluorescent agent within the tissues of the patient.

[0188] In another aspect, the corrections for excitation light leak-through and autofluorescence may be implemented separately. In this other aspect, a subtraction of the effects of excitation light leak-through may be performed prior to the diffuse reflectance correction described herein below, and a subtraction of the effects of autofluorescence may be performed after the diffuse reflectance correction.

#### c) Diffuse Reflectance Correction Subunit

[0189] Referring again to FIG. 13, the processing unit **236** further includes a diffuse reflectance correction subunit **1306**. In an aspect, the diffuse reflectance correction subunit **1306** may correct the measured fluorescence data to remove the effects of changes to the optical properties (absorption and scattering) of the tissues of the patient **202** during monitoring of renal extraction of an exogenous fluorescent agent within the tissues of a patient. As described herein above, the optical properties of the tissues may change due to any one or more factors including, but not limited to: vasodilation, vasoconstriction, oxygen saturation, hydration, edema, and any other suitable factor within the region of interest monitored by the system, associated with changes in the concentrations of endogenous chromophores such as hemoglobin and melanin.

[0190] Without being limited to any particular theory, the fluorescence measurements obtained by the system **200** that are used to determine renal function include emission-wavelength photons that are detected by the second (filtered) light detector **224**. These emission-wavelength photons are emitted by the exogenous fluorescence agent introduced into the tissues of the patient in response to illumination by excitation-wavelength photons. The emission-wavelength photons travel from the fluorescence source (i.e. the exogenous fluorescence agent) to the second (filtered) light detector **224** through third region **210** of the patient's skin. However, the emission-wavelength light that is detected by the second (filtered) light detector **224** may also include autofluorescence emitted by endogenous fluorophores such as keratin and collagen within the tissues of the patient, as well as leak-through of excitatory-wavelength light through the optical filter **244** of the second light detector **224**. The excitation-wavelength photons that induce fluorescence of the exogenous fluorescent agent are produced by the first light source **218** and are directed into the first region **206** of the patient's skin. If the optical properties of the patient's skin (scattering and/or absorption) varies over the time interval at which the detector data used to determine renal function is acquired (i.e. from a few hours to about 24 hours

or more), the accuracy of the fluorescence measurements may be impacted, as discussed previously above.

**[0191]** During each measurement cycle in an aspect, the system **200** may direct light into the first region **206** of the patient's skin with a pulse of emission-wavelength light and a pulse of excitation-wavelength light in an alternating series and may detect all light emerging from the second region of the patient's skin using the first (unfiltered) light detector **222** and a portion of the light emerging from the third region **210** of the patient's skin using the second (filtered) light detector **224**. The light intensity detected by each combination of excitation and emission wavelength illumination of the first region **206** and detection by the unfiltered/filtered light detectors **222/224** contain information not only about the concentration of the exogenous fluorescent agent in the patient's tissues, but also information about the optical properties of the patient's skin.

TABLE 2

Light Detector Measurements After Temperature and Power Fluctuation Corrections		
Illumination wavelength	First (Reference) Light Detector Unfiltered	Second (Primary) Light Detector Filtered
Excitation-wavelength	$Flr_{meas}$	$Flr_{meas}$
Emission-wavelength	$DR_{em}$	$DR_{em,filtered}$

**[0192]** The primary measurement of fluorescence is  $Flr_{meas}$ , the intensity of fluorescent light measured at the filtered detector.

**[0193]** The diffuse reflectance measurement  $Flr_{meas}$  represents the propagation of photons to the non-filtered arm and is composed primarily of excitation photons.

**[0194]**  $DR_{em}$  and  $DR_{em,filtered}$  represent the propagation of emission-only photons.

**[0195]** Referring to Table 2, light intensity measured by the second (filtered) light detector **224** during illumination by the excitation-wavelength light captures the raw intensity of light emitted by the exogenous fluorescent agents ( $Flr_{meas}$ ) prior to any corrections for tissue optical properties in various aspects. After baseline subtraction corrections as described herein previously, the emission-wavelength light contained in  $Flr_{meas}$  is assumed to originate predominantly from the exogenous fluorescent agent, with only minor contributions due to auto-fluorescence by endogenous chromophores, and is therefore termed  $Flr_{agent}$ . In an aspect, if no change in the optical properties of the patient's skin is assumed, all autofluorescence contributions would be subtracted off during the baseline correction described herein above.

**[0196]** However, if the optical properties of the patient's skin change during the acquisition of data, slightly more or less of the autofluorescence may emerge from the patient's skin at the emission wavelength, thereby introducing uncertainty into the accuracy of the background subtraction correction performed previously. In addition, varied skin optical properties may further alter the intensity of light at the excitation wavelength reaching the exogenous fluorescent agent, thereby altering the amount of energy absorbed by the exogenous fluorescent agent and the intensity of induced fluorescence from the exogenous fluorescent emitted in response to illumination by the excitation-wavelength light. In various aspects, the remaining three light measure-

ments enable monitoring of the optical properties of the patient's skin and provide data that may be used to adjust for any changes in the optical properties of the patient's skin.

**[0197]** Referring again to Table 2, the represented signals  $DR_{ex,meas}$  and  $Flr_{meas}$ , which have been corrected for variations in temperature and optical output are further processed to signals attributed only to photons of the desired wavelength prior to applying a diffuse reflectance correction. The number of photons due to either diffuse reflectance, excitation or fluorescence on either detector depends on light directionality and the gain of the detector at the detected wavelength, as shown below:

$$DR_{ex,meas} = A_1 * DR_{ex,photons} + B_1 * Flr_{photons}$$

$$Flr_{meas} = A_2 * DR_{ex,photons} + B_2 * Flr_{photons}$$

where the coefficients  $A_1$ ,  $A_2$ ,  $B_1$ ,  $B_2$  are composed of a directionality and gain factor, e.g.  $A_1 = d450_{SPM1} * G_{SPM1@450}$

**[0198]** Isolation of the signals arising from fluorescence emission and diffuse reflectance, excitation wavelength photons is performed as follows:

$$B_1 \left( \frac{B_2}{B_1} - \frac{A_2}{A_1} \right) Flr_{photons} = Flr_{meas} - \frac{A_2}{A_1} DR_{ex,meas}$$

$$A_2 \left( \frac{A_1}{A_2} - \frac{B_1}{B_2} \right) DR_{ex,photons} = DR_{ex,meas} - \frac{B_1}{B_2} Flr_{meas}$$

**[0199]** Since the renal function monitor measures rate, which is independent of magnitude, the constant terms in front of the photons signals (e.g.  $B_1(B_2/B_1 - A_2/A_1)$ ) are not needed, as demonstrated below.

$$IF = C_0 + C_1 e^{-t/\tau} \rightarrow \log(IF) = \log(C_1) - \frac{1}{t}$$

**[0200]** As such, the terms  $A_2/A_1$  (or  $C_{exLT}$ ) and  $B_1/B_2$  (or  $C_{FlrLT}$ ) can be determined experimentally to isolate  $Flr_{photons}$  and  $DR_{ex,photons}$ , respectively.

**[0201]** The table below represents the names of the signals used to represent each of the four measured signals in the diffuse reflectance correction development. Note that either of the described preprocessing paths can be followed to arrive at signals that can be used to develop the correction.

TABLE 3

Light Detector Measurements Used to Obtain Fluorescence Measurements Corrected for Variable Tissue Optical Properties	
Generic signal name	Preprocessed signals for use
$DR_{ex}$	$DR_{ex,photons}$ or $DR_{ex2}$
$Flr$	$Flr_{photons}$ or $Flr_2$
$DR_{em}$	$DR_{em}$
$DR_{em,filtered}$	$DR_{em,filtered}$

**[0202]** where either of the excitation wavelength signals may be used as alternate methods for obtaining a diffuse reflectance correction with either of the described pre-processing methods.

[0203] Referring again to Table 2, light intensity measured by the first (unfiltered reference) light detector **222** during illumination by excitation-wavelength light captures a measure of the diffuse reflectance of excitation-wavelength light propagated through the patient's skin ( $DR_{ex,meas}$ ). Although the first light detector **222** is configured to detect both excitation-wavelength and emission-wavelength light, the intensity of the excitation-wavelength light is orders of magnitude higher than the intensity of the emission-wavelength light as a result of the lower efficiency of producing light via fluorescence. In various aspects, the proportion of emission-wavelength light within  $DR_{ex,meas}$  is assumed to be negligible. In other aspects, the proportion of emission-wavelength light within  $DR_{ex,meas}$  is estimated and subtracted. Without being limited to any particular theory, because the intensity of the excitation-wavelength light directed into the patient's skin is assumed to be relatively constant with negligible losses due to absorption by the exogenous fluorescent agent, and is subject to power corrections as described herein previously,  $DR_{ex,meas}$  serves as a benchmark measurement to assess changes in the optical properties of the patient's skin with respect to the excitation-wavelength light.

[0204] Light intensity measured by the first (unfiltered reference) light detector **222** during illumination by emission-wavelength light captures a measure of the diffuse reflectance of emission-wavelength light propagated through the patient's skin ( $DR_{em}$ ). Without being limited to any particular theory, because the exogenous fluorescent agent is not induced to emit emission-wavelength light due to the absence of excitation-wavelength illumination during this phase of the data acquisition cycle, and because the intensity of the emission-wavelength light directed into the patient's skin is relatively constant and subject to power corrections as described herein previously,  $DR_{em}$  serves as a benchmark measurement to assess changes in the optical properties of the patient's skin with respect to the emission-wavelength light.

[0205] Light intensity measured by the second (filtered) light detector **224** during illumination by emission-wavelength light captures a second measure of the diffuse reflectance of emission-wavelength light propagated through the patient's skin ( $DR_{em,filtered}$ ). In one aspect,  $DR_{em,filtered}$  is subject to the same assumptions as  $DR_{em}$  as described herein above. In addition,  $DR_{em,filtered}$  provides a means of assessing heterogeneity of the tissue's optical properties. Because  $DR_{em,filtered}$  is measured by the second light detector **224** configured to detect light emerging from the patient's skin at the third region **210** (see FIG. 2), the intensity of light measured in  $DR_{em,filtered}$  has propagated along an optical path through the skin of the patient that is different from the optical path travelled by the light measured in  $DR_{em}$ . Without being limited to any particular theory, because the distances of the first detector aperture **1004** and second light aperture **2006** through which light is delivered to the first and second light detectors **222/224**, respectively are designed to be equidistant from the light delivery aperture **1002** (see FIG. 10), any differences between  $DR_{em,filtered}$  and  $DR_{em}$  are assumed to be a result of heterogeneity on the optical properties of the skin traversed by the two different optical paths.

[0206] In one aspect, the intrinsic fluorescence (IF), defined here as the measured fluorescence at the emission

wavelength attributable only to emission by the exogenous fluorescent agent, may be calculated according to Eqn. (20):

$$IF = \frac{F_{meas}}{DR_{ex}^{k_{ex}} DR_{em}^{k_{em}} DR_{em,filtered}^{k_{em,filtered}}} \quad \text{Eqn. (20)}$$

[0207] The factors IF, Flr,  $DR_{ex}$ ,  $DR_{em}$ , and  $DR_{em,filtered}$  are defined herein above. As expressed in Eqn. (20), each of the diffuse reflectance correction measurement signals  $DR_{ex}$ ,  $DR_{em}$ , and  $DR_{em,filtered}$  factors are raised to the powers  $k_{ex}$ ,  $k_{em}$ , and  $k_{em,filtered}$  respectively. In an aspect, each measurement in Table 2 is subjected to the power/temperature corrections and background subtraction corrections as described herein above (see FIGS. 22A and 22B) before applying the diffuse reflectance correction of Eqn. (20).

[0208] In various aspects, the values of  $k_{ex}$ ,  $k_{em}$ , and  $k_{em,filtered}$  may be determined empirically. Non-limiting examples of suitable empirical methods for determining suitable values for  $k_{ex}$ ,  $k_{em}$ , and  $k_{em,filtered}$  include a global error map method and a linear regression method, both described in detail herein below.

[0209] In one aspect, once the values for each of the powers ( $k_{ex}$ ,  $k_{em}$ ,  $k_{em,filtered}$ ) are identified, the same set of exponents may be reused for subsequent measurements of intrinsic fluorescence. Non-limiting examples of applications of the systems and methods described herein in which a set of selected exponents may be reused includes: repeated measurements on the same patient using the same sensor head **204**; repeated measurements using the same sensor head on different patients of the same species; repeated measurements using different sensor heads with the same design on patients of the same species; repeated measurements using different sensor heads with different designs on patients of the same species; repeated measurements using different sensor heads with the different designs on patients of the different species; and any other suitable applications of the systems and methods described herein. In another aspect, the exponents may be updated with repeated use of the systems and methods described herein. In this other aspect, new sets of exponents may be determined for each use of the system and methods, and the stored sets of exponents may be periodically or continuously evaluated to assess whether an updated selection of exponents is indicated. By way of non-limiting example, if an analysis of multiple sets of exponents determined that the exponents did not vary outside of a threshold range in previous uses of the system, the system may be used to conduct measurements using the previous set of exponents, a mean/median of all previous sets of exponents, or any other estimate of suitable exponents based on previous values of exponents. In this non-limiting example, if an analysis of multiple sets of previous exponents determined that the exponents varied outside of a threshold range, de novo selection of exponents using one of the methods described herein below may be indicated.

#### Global Error Map Method

[0210] In one aspect, the values of the powers used in Eqn. (20) above are determined empirically using a global error surface method.

[0211] A flow chart illustrating the various steps of a global error surface method **1400** is illustrated in FIG. 14.

The method in this aspect includes selecting ranges of values for each of the powers ( $k_{ex}$ ,  $k_{em}$ ,  $k_{em,filtered}$ ) for each of the diffuse reflectance signals ( $DR_{ex}$ ,  $DR_{em}$ ,  $DR_{em,filtered}$ ) are selected by a user at step **1402**. In various aspects, the ranges of values for each of the powers may be influenced by any one or more of a variety of factors including, but not limited to: the design of the system **200**, including the design of the sensor head **204**; the properties of the selected exogenous fluorescent agent such as excitatory/emission wavelengths, absorption efficiency, emission efficiency, and concentration of initial dose in the patient's tissues; the species of the patient **202** and corresponding concentrations of endogenous chromophores; the position of the sensor head **204** on the patient **202**; and any other relevant factor.

**[0212]** In one aspect, the method may include choosing a wide range for each coefficient ( $k_{ex}$ ,  $k_{em}$ ,  $k_{em,filtered}$ ) and conduct a broad search. The error surfaces from this broad search may be analyzed to locate wells in the error surface and the associated ranges for each of the coefficients. The method in this one aspect includes adapting the ranges of each coefficient to include the regions from the broad search within which wells in the error surface were observed and repeating the analysis. This method may be iterated until a suitably fine resolution is achieved that is capable of accurately capturing the minimum error. In one non-limiting example, for a human patient, the selected ranges of potential factors may be [0,2] for  $k_{ex}$ , [0,4] for  $k_{em}$ , and [-4,0] for  $k_{em,filtered}$ .

**[0213]** Referring again to FIG. **14**, step sizes may be selected at **1404** for the ranges of values selected at **1402** for each power  $k_{ex}$ ,  $k_{em}$ ,  $k_{em,filtered}$ . In an aspect, the step size for each factor may be selected based on any one or more of at least several factors including, but not limited to: the anticipated sensitivity of the IF values calculated by Eqn. (20) to changes in each factor; a suitable total number of combinations of powers used to calculate IF considered factors including available computational resources, acceptable data processing times, or any other relevant factors; and any other suitable criterion for step size.

**[0214]** In various aspects, the step sizes may be the same value for all powers  $k_{ex}$ ,  $k_{em}$ ,  $k_{em,filtered}$ . By way of non-limiting example, the step size for all powers may be 0.5. In various other aspects, the step sizes may be constant for all values of a single power  $k_{ex}$ ,  $k_{em}$ ,  $k_{em,filtered}$ , but the step sizes selected for each power may be different between different powers. By way of non-limiting example, the selected step size for  $k_{ex}$  may be 0.01 and the selected step size for  $k_{em}$  and  $k_{em,filtered}$  may be 0.6. In various additional aspects, the step size within one or more of the powers may vary within the range of values for each power. By way of non-limiting example, the selected step sizes for  $k_{ex}$  may be non-linearly distributed about the mean value. In this non-limiting example, the vector of potential values for  $k_{ex}$  may be [0 0.5 0.75 0.9 1 1.1 1.25 1.5 2]. In these various additional aspects, the step size may be reduced within subranges of values for a power for which the IF calculated by Eqn. (20) is predicted to be more sensitive to small changes in that power. Non-limiting examples of suitable varying step sizes within a range of values for a single power include: different step sizes selected by a user, random step sizes, a linear increase and/or decrease in step size, a non-linear distribution of different step sizes such as a logarithmic distribution, an exponential distribution, or any other suitable non-linear distribution of step sizes.

**[0215]** Referring again to FIG. **14**, the ranges of exponents selected at **1402**, together with the step sizes selected at step **1404**, may be used to form vectors of potential values of  $k_{ex}$ ,  $k_{em}$ ,  $k_{em,filtered}$  at **1406**. By way of non-limiting example, assuming selected ranges of potential exponents of [0,2] for  $k_{ex}$ , [0,4] for  $k_{em}$ , and [-4,0] for  $k_{em,filtered}$ , and assuming a constant step size of 0.5 for all powers, the vectors created at **1406** are:

$$k_{ex} = [0.0 \ 0.5 \ 1.0 \ 1.5 \ 2.0] \text{ (5 values)}$$

$$k_{em} = [0.0 \ 0.5 \ 1.0 \ 1.5 \ 2.0 \ 2.5 \ 3.0 \ 3.5 \ 4.0] \text{ (9 values)}$$

$$k_{em,filtered} = [-4.0 \ -3.5 \ -3.0 \ -2.5 \ -2.0 \ -1.5 \ -1.0 \ -0.5 \ -0.0] \text{ (9 values)}$$

**[0216]** Referring again to FIG. **14**, for each combination of exponents amongst all vectors formed at **1406**, IF is calculated from the measurements  $Flr$ ,  $DR_{ex}$ ,  $DR_{em}$ , and  $DR_{em,filtered}$  at **1408** using Eqn. (20). For each combination of exponents, a plurality of IF values are calculated at **1408** in which each IF value corresponds to one of the data acquisition cycles (i.e. a single sequence of emission-wavelength illumination followed by excitatory-wavelength illumination as illustrated in FIG. **5**). By way of non-limiting example, using the vectors of potential exponents listed herein above, a total of 405 (5\*9\*9) pluralities of IF signals would be calculated.

**[0217]** In an aspect, the plurality of combinations of potential exponents may be evaluated to select one combination of exponents from the plurality to assign for use in subsequent diffuse reflectance corrections calculated using Eqn. (20). Referring again to FIG. **14**, an estimate of error of the corrected  $Flr$  signal data (i.e. IF signal data calculated using Eqn. (20)) may be calculated at **1410**. Any estimate of error may be calculated at **1410** including, but not limited to, a quantity related to residuals of the IF signal data relative to a curve fit of the IF signal data. Any type of known curve-fitting method may be used to curve-fit the IF signal data including, but not limited to, a single-exponential curve fit. Without being limited to any particular theory, it is thought that the rate of clearance of an exogenous fluorescent agent, such as MB-102, from the kidneys is expected to be a constant exponential decay characterized by the renal decay time constant RDTC.

**[0218]** In an aspect, a subset of the  $Flr$  signals corresponding to the post-agent administration period **1508/1510** may be selected to estimate an error for each combination of exponents used to calculate the IF signals using Eqn. (20) against a reference curve, including, but not limited to, a curve obtained using plasma measurements. By way of non-limiting example, if the exogenous fluorescent agent is introduced into the tissues of the patient by way of intravenous injection, the post-agent administration period includes the period after injection in which the exogenous fluorescent agent has undergone sufficient diffusion from the blood into the extracellular fluid space throughout the patient so that the decay of the fluorescence is representative of clearance of the agent by the kidneys. In various aspects, the post-agent administration period **1508/1510** of the  $Flr$  measurements may be selected by any suitable method without limitation. Non-limiting examples of suitable methods for identifying a post-agent administration period include: selection via inspection by a user and an automated selection

method such as the equilibration detection method enabled by the equilibrium selection subunit **1308** as described in detail herein below.

**[0219]** FIG. **15** is a graph of fluorescence measurements obtained from a patient over a period of about 10 hours after injection of an exogenous fluorescence agent (MB-102) after a pre-injection period of about 3 hours. Referring to FIG. **15**, the pre-injection/baseline period **1502** is characterized by a relatively low and stable fluorescence level, likely due the absence of endogenous fluorescent agent in the blood of the patient. After the injection **1503** of the exogenous fluorescence agent, the fluorescence measurements exhibit a sharp increase **1504** to a peak concentration **1506**, followed by a relatively smooth exponential decrease **1508** back to background fluorescence levels as the kidneys eliminate the exogenous fluorescence agent from the blood of the patient. Without being limited to any particular theory, it is thought the injected exogenous fluorescence agent is likely equilibrated across the extra-cellular space once the decay of the fluorescence is well-described by a linear fit (or a line on semi-log plot). FIG. **16** is an enlargement of the graph of FIG. **15** showing a comparison of the measured fluorescence data to a linear curve fit **1604** to the log of the IF signal within a portion of the post-equilibrium period **1510**, demonstrating the close fit of the single-exponential curve-fit to the IF signal data.

**[0220]** In an aspect, the log of the calculated IF signal value may be fit with a line and an error of the curve fit relative to the individual IF values may be compared to the IF signals calculated using Eqn. (20) for each of the plurality of combinations of exponents to calculate the error at **1410**. Any statistical summary parameter suitable for quantifying the error of the single-exponent curve fit and the corresponding IF signal values may be used without limitation including, but not limited to: root mean square (RMS) error, average absolute deviation, mean signed deviation, mean squared deviation, and any other suitable statistical summary parameter. In one aspect, the calculated error at **1410** may be the normalized RMS error of the linear fit of the log(IF) signals. In this aspect, the normalized RMS error calculated at **1410** is a single numerical quantity to facilitate the subsequent selection of a single combination of exponents from the plurality of combinations identified at **1406**.

**[0221]** Referring again to FIG. **14**, the method **1400** includes selecting a single combination of exponents at **1412** from among the plurality of combinations for which IF was calculated at **1408**. Without being limited to any particular theory, it is assumed that the combination of exponents associated with a calculated IF signal that minimizes the error calculated at **1410** is best suited for correcting the measured Flr signals to remove the effects of variation in the optical properties of the patient's skin during data acquisition within the post-agent administration period **1508/1510**. In various aspects, any known method of identifying the combination of exponents may be used without limitation including, but not limited to, selecting the single combinations of exponents from a map of all error values corresponding to all combinations of exponents.

**[0222]** In various aspects, the plurality of error values corresponding to the plurality of combinations of exponents may be transformed into an error map comprising a three-dimensional volume in which each of the three dimensions corresponds to the powers used in Eqn. (20):  $k_{ex}$ ,  $k_{em}$ , and  $k_{em,filtered}$  respectively. In these various aspects, each error

value corresponding to one of the combinations of exponents is mapped to a coordinate ( $k_{ex1}$ ,  $k_{em1}$ , and  $k_{em,filtered1}$ ) within the three-dimensional volume, where  $k_{ex1}$ ,  $k_{em1}$ , and  $k_{em,filtered1}$  are the numerical values for one combination of exponents. In various aspects, each error values may be mapped to the three-dimensional volume in any known format including, but not limited to: a number, a color, a grayscale value, and any other suitable format.

**[0223]** In an aspect, the three-dimensional map of error values described above may be transformed into a plurality of error surfaces corresponding to a planar map of the error values associated with a single value of one of the powers  $k_{ex}$ ,  $k_{em}$ , and  $k_{em,filtered}$  with the full numerical range of the remaining two exponents acting as a horizontal axis and a vertical axis of the error map.

**[0224]** FIG. **17** is an error map of the normalized RMS errors of the single-exponential curve-fits of the calculated IF signals maps to the full ranges of  $k_{em,filtered}$  (horizontal axis) and  $k_{ex}$  (vertical axis) at a constant value of  $k_{em}$  in which the normalized RMS errors are represented as colors on the error map. In one aspect, the normalized RMS value calculated for each coefficient may be normalized according to Eqn. (21):

$$RMSE_{CV} = \sqrt{\sum \left[ \frac{IF_{agent} - \text{fit}(IF_{agent})^2}{\text{fit}(IF_{agent})} \right]} \quad \text{Eqn. (21)}$$

in which  $IF_{agent}$  is the calculated IF signal, and  $\text{fit}(IF_{agent})$  is the corresponding value of the single-coefficient curve fit equation. In one aspect, the global error map method of determining the powers to be used in the correction for variation in skin optical properties by analyzing a single measurement set as described herein above. In another aspect, the global error map method may analyze and combine multiple measurement datasets for multiple individuals obtained using the same system and/or sensor head. In yet another aspect, the global error map method may analyze multiple measurement datasets from multiple individuals obtained using multiple systems and sensor heads. In an aspect, the powers to be used in the correction according to Eqn. (20) may be determined for each measurement of each individual. In other aspects, the powers to be used may be obtained using at least several different measurement datasets and the powers so obtained may be stored for subsequent use for measurement datasets obtained from a new individual and or obtained using a different system and/or sensor. In various aspects, the projection across each of the error surfaces (a  $k_{em,filtered}-k_{ex}$  projection, a  $k_{em,filtered}-k_{em}$  projection, and a  $k_{em}-k_{ex}$  projection) may be inspected to determine whether the power ranges defined at **1402** were adequate. In one aspect, the error surface may be inspected to confirm that the map includes a clearly defined minimum value. In this one aspect, if the inspection of the error map does not identify a minimum value, the ranges of one or more power vales may be revised and the method **1400** may be repeated. In one aspect, an assessment of the optical properties of the skin of the patient (e.g. melanin absorbance, blood content, and/or scattering coefficient) may be used to categorize the patient so that an appropriate set of coefficients may be selected for that category.

**[0225]** In an aspect, the combination of exponents  $k_{ex}$ ,  $k_{em}$ , and  $k_{em,filtered}$  may be stored and used for subsequent mea-



measurements conducted by the system 200. FIG. 18 is a graph comparing the raw fluorescence signal (blue line) to the calculated IF signal (red line) for a measurement data set. In an additional aspect, a global correction may be calculated by combining measurements obtained using a plurality of different systems and/or sensor heads and identifying the combination of exponents corresponding to an overall minimum error value.

#### Linear Regression Method

[0226] In one aspect, the values of the power coefficients used in Eqn. (20) above are determined empirically using a linear regression method. A flow chart illustrating the various steps of the linear regression method of obtaining a correction in the form of a regression equation with predictor variables ( $DR_{ex}$ ,  $DR_{em}$ ,  $DR_{em,filtered}$ ) is provided in FIG. 19.

[0227] Referring to FIG. 19, the method 1900 may include log transforming Flr to  $\log(\text{Flr})$  to prepare the raw fluorescence measurements Flr for analysis at 1902. FIG. 20 is a graph of  $\log(\text{Flr})$  produced at 1902. Referring again to FIG. 19, the method 1900 may further include selecting a region of stable optical properties 2002 (see FIG. 20) in an aspect. In this aspect, regions of stable optical properties 2002 typically correspond to linear segments on the graph of  $\log(\text{Flr})$  as shown in FIG. 20. In this aspect, the method 1900 further includes obtaining a linear regression model 2004 within the region of stable optical properties 2002 at 1906. The linear regression model 2004 may be obtained using any regression method without limitation including, but not limited to, a multi-variable linear regression modeling method.

[0228] Referring again to FIG. 19, the method 1900 may further include extending the linear regression model 2004 obtained within the region of stable optical properties 2002 to produce an extended linear regression 2008 extending into a region of variable optical properties 2010 at 1908. In an aspect, the region of variable optical properties 2010 is characterized by a non-linear profile within the graph of  $\log(\text{Flr})$  as illustrated in FIG. 20.

[0229] Referring again to FIG. 19, the method 1900 may further include obtaining a linear regression model 2004 with predictor variables Flr,  $DR_{ex}$ ,  $DR_{em}$ , and  $DR_{em,filtered}$  at 1910 and the linear curve fit 2004 as the predicted response. The extension of the linear regression 2008 produced at 1908 may be used to train the linear regression model obtained at 1910.

[0230] The linear regression model may be developed using a measurement data set obtained from a single individual and/or a single system and sensor head in one aspect. In another aspect, the linear regression model may be developed using multiple measurement datasets obtained from multiple individuals and/or multiple systems and sensor heads. In some aspects, a linear regression model may be developed de novo for each new measurement data set obtained for an individual. In at least some other aspects, the constants and parameters characterizing a linear regression model developed as described herein above may be stored for subsequent use in lieu of developing a linear regression model de novo for each measurement data set obtained as described herein above.

#### d) Fault Detection Subunit

[0231] Referring again to FIG. 13, the processing unit 236 of the controller 212 may further include a fault detection

subunit 1312 configured to monitor the function of the light sources 218/220 and light detectors 222/224 and to inform the user of any irregularities of any detected faults within the system 200 via the display unit 216. In various aspects, the fault detection subunit 1312 may enable the basic identification of fault and notice states by examining the signal levels received from the light sources 218/220 and light detectors 222/224 and associated additional temperature sensors 228 and additional light detectors 226 of the sensor head 204 (see FIG. 2). In various aspects, the signal magnitudes (see Eqn. (1)) and average signals may be used to determine the peak and nadir levels of the modulation of the LED light sources 218/220. The nadir of the signal, defined herein as the average signal minus half the peak-to-peak signal, may be used to monitor ambient light levels in one aspect. Without being limited to any particular theory, additional contributions to the nadir levels of the modulated signals, such as amplifier DC offset, may be neglected as small and constant relative to the contributions of ambient light leakage. In an aspect, if the detected ambient light levels register in excess of about one quarter of the high-speed ADC 1102 range at low detector amplifier gain, an ambient light notice is issued to the user via the display unit 216.

[0232] In various other aspects, saturation of the light detectors 222/224 detectors may also be monitored by the fault detection subunit 1312. In these other aspects, the saturation may be monitored by calculating the peak value of the signal, defined herein as the average signal value plus half the peak-to-peak signal. If the signal's peak value falls within is within 5% of saturation of the ADC range, the fault detection subunit 1312 may issue a saturation notice to the user via the display unit 216. If saturation event is detected by the fault detection subunit 1312, the ambient light level may then be checked to determine if the saturation event is associated with ambient light saturation, defined herein as a saturation event occurring concurrently with an ambient light notice as described herein above. If an ambient light saturation event is detected, the fault detection subunit 1312 issues an ambient light saturation notice to the user via the display unit 216, and data acquisition by the acquisition unit 234 is continued in this notice state to allow the user to resolve the condition. If a saturation event is detected that is not associated with an excess of ambient light, the fault detection unit may signal the light detector control unit 232 to perform an adjustment of detector gain and/or may signal the light source control unit 230 to perform an adjustment to the LED current source 1126 to adjust LED intensity. In various aspects, the fault detection unit issues a notification to the user via the display unit to report either the ambient light saturation event, or the saturation event not associated with an excess of ambient light. In some aspects, if a saturation event is detected, but the automatic gain adjustment has been disabled by a user when the system 200 is configured in the Engineering Mode as described herein above, the user is also notified via the display unit.

#### e) Post-Agent Administration Selection Subunit

[0233] Referring again to FIG. 13, the processing unit 236 may further include a post-agent administration selection subunit 1308 configured to automatically identify the portion of the measurement data set that corresponds to the post-agent administration period 1508/1510 (see FIG. 15). Referring against to FIG. 15, as described herein above, after

an exogenous fluorescent agent, such as MB-102, is injected into the bloodstream of a patient, the exogenous fluorescent agent undergoes an equilibration period of diffusion from the bloodstream into the rest of the extracellular tissues of the patient. After the agent injection **1503**, the temporal profile of the fluorescence signal  $IF_r$  may be characterized as a two-exponential signal profile described by Eqn. (22):

$$IF_{pre-equilibration} = C_0 + C_1 e^{-t/\tau_1} + C_2 e^{-t/\tau_2} \quad \text{Eqn. (22)}$$

in which  $C_0$  is the baseline signal that is typically removed by baseline subtraction as described herein above.

[**0234**] Referring again to FIG. **15**, once the diffusion of the exogenous fluorescent agent into the extracellular tissues of the patient reaches a quasi-steady state condition, post-equilibration period **1510** is achieved and the fluorescence signal may be characterized as a linear decay. Without being limited to any particular theory, the post-equilibration region of the measurement data set is assumed to be characterized as a region of the IF temporal profile that, when log-transformed, is well-described by a linear equation. In one aspect, the post-equilibration region is well-described described by Eqn. (23):

$$IF_{post-equilibration} = C_0 + C_1 e^{-t/\tau} \quad \text{Eqn. (23)}$$

[**0235**] In an aspect, the post-agent administration selection subunit **1308** may identify the post-agent administration period **1510** automatically by performing a single-exponent curve fit at different portions of the IF data set and analyzing the associated curve fitting errors for each of the different portions. In various aspects, the post-agent administration selection subunit **1308** may select the earliest-occurring portion of the IF data set in which the curve-fit error associated with a single-exponent curve fit falls below a threshold value as the initial post-agent administration portion of the IF data set suitable for data correction and analysis as described herein above. Any analysis method suitable for comparing curve-fit errors association with single-exponential curve fits of different portions of the IF data set may be used in the post-agent administration selection subunit **1308** including, but not limited to, linear curve-fitting portions of the IF data set falling within overlapping or non-overlapping data windows and comparing the curve-fit errors of the corresponding data windows. In an aspect, the post-agent administration selection subunit **1308** may produce at least one signal configured to signal the time range within the IF data set corresponding to the post-agent administration period **1508/1510** to the diffuse reflectance correction subunit **1306** and/or RDTC calculation subunit **1310** to enable the selection of a suitable portion of the IF data set to correct and analyze as disclosed herein.

[**0236**] In another aspect, a linear fit and a 2-exponential fits to the IF data may be compared. In this other aspect, equilibration may be identified as complete once the fitting error is equivalent (corrected for the extra degrees of freedom in the 2-exponential fit).

#### f) RDTC Calculation Subunit

[**0237**] In various aspects, the system **200** is configured to transform the various measurements from the light detectors

**222/224** and associated light sources **218/220** and other thermal and light sensors into a corrected intrinsic fluorescent (IF) signal corresponding to the detected fluorescence attributable solely to emission of fluorescence by the exogenous fluorescent agent at the emission wavelength in response to illumination by light at the excitatory wavelength. In various aspects, the exponential decrease of the IF signals during the post-agent administration portion of the IF data set may be analyzed to monitor and quantify renal function.

[**0238**] In one aspect, the exponential decrease of the IF signals during the post-agent administration portion of the IF data set may be transformed into a glomerular filtration rate (GFR) configured to quantify renal function. In another aspect, the exponential decrease of the IF signals during the post-equilibration portion of the IF data set may be transformed into a renal decay time constant (RDTC), also configured to quantify renal function. In another aspect, the exponential decrease of the IF signals during the post-equilibration portion of the IF data set may be transformed into a renal decay rate, also configured to quantify renal function.

[**0239**] Referring again to FIG. **13**, the processing unit **236** may further include an RDTC calculation subunit **1310** configured to automatically transform the IF signals into a renal decay time constant (RDTC). As used herein, renal decay time constant (RDTC) is defined as the time constant associated with the post-equilibration single-exponential decay described in Eqn. (23) herein above. In one aspect, after accurate baseline subtraction by the baseline subtraction subunit **1304**, the renal decay time constant  $t$  may be calculated by performing a linear regression on the log-transformed IF signal data ( $\log(IF)$ ), as described in Eqn. (24):

$$\log(IF) = \log(C_1) - \frac{1}{\tau} t \quad \text{Eqn. (24)}$$

[**0240**] In various aspects the RDTC calculation subunit **1310** may produce signals configured to produce a display of the calculated RDTC using the display unit **216**. The display of the calculated RDTC may be provided to the display unit **216** in any suitable format including, but not limited to: a graph of RDTC as a function of time, a single discrete RDTC value, a table of RDTC values as a function of time, a color-coded display or other graphical representation configured to specific whether the calculated RDTC may be classified as normal/healthy, abnormal, high, low, and any other suitable classification. In various other aspects, any of the graphical formats described above may be continuously or non-continuously updates as additional data is obtained and analyzed. In one aspect, the RDTC calculation subunit **1310** may calculate RDTC as described herein above within non-overlapping and/or overlapping windows within the IF data set.

[**0241**] In another aspect, the RDTC calculation subunit **1310** may convert RDTC into glomerular filtration rate (GFR) using known methods. In this aspect, RDTC may be inverted and multiplied by a slope, resulting in cGFR, a prediction of GFR that may be corrected for body size (e.g. body surface area, or volume of distribution).

## v) Memory

[0242] Referring again to FIG. 2, the controller 212 of the system 200 may further include a memory 242 configured to facilitate data storage in the system 200. In some embodiments, the memory 242 includes a plurality of storage components such as, but not limited to, a hard disk drive, flash memory, random access memory, and a magnetic or optical disk. Alternatively or additionally, the memory 242 may include remote storage such a server in communication with the controller 212. The memory 242 stores at least one computer program that, when received by the at least one processor, cause the at least one processor to perform any of the functions of the controller 212 described above. In one implementation, the memory 242 may be or contain a computer-readable medium, such as a floppy disk device, a hard disk device, an optical disk device, or a tape device, a flash memory or other similar solid state memory device, or an array of devices, including devices in a storage area network or other configurations. A computer program product can be tangibly embodied in an information carrier. The computer program product may also contain instructions that, when executed, perform one or more functions, such as those described herein. The information carrier may be a non-transitory computer- or machine-readable medium, such as the memory 242 or memory on the processor 238.

[0243] In various aspects, the system 200 may record raw measurements and processed data to a series of files. Each file may contain a header, which contains information about the operator, instrument, and session. Each experimental session records a set of files into a separate folder for each sensor head used in that session. The raw data file may contain in-phase, quadrature, and average measurements from the detectors and monitors during the active periods of both the excitation wavelength and the emission wavelength LEDs, along with the gain settings of the LEDs and detectors at the time of data acquisition.

[0244] In various other aspects, the processed data file may contain the fluorescence and diffuse reflectance measurements after magnitude calculation and correction for the monitor readings, along with the gain settings of the LEDs and detectors. The intrinsic fluorescence data file may contain the intrinsic fluorescence measurements resulting from the diffuse reflectance correction of the raw fluorescence signals. The GFR file may contain the calculated GFR as a function of time, classified to indicate whether post-equilibration has occurred, along with confidence bounds. The telemetry file may contain the temperature and voltage measurements. The event record file may contain both user and automatically generated event records.

## vi) GUI Unit

[0245] Referring again to FIG. 2, the controller 212 may include a GUI unit 240 configured to receive a plurality of signals encoding various measured and transformed data from other units of the system in various aspects. In addition, the GUI unit may be configured to produce signals configured to operate the display unit 216 in order to display data, frames, forms, and/or any other communications of information between the user and the system 200.

## vii) Processor

[0246] Referring again to FIG. 2, the controller 212 may further include a processor 238. The processor 238 may include any type of conventional processor, microprocessor,

or processing logic that interprets and executes instructions. The processor 238 may be configured to process instructions for execution within the controller 212, including instructions stored in the memory 242 to display graphical information for a GUI on an external input/output device, such as display unit 216 coupled to a high speed interface. In other implementations, multiple processors and/or multiple buses may be used, as appropriate, along with multiple memories and types of memory. Also, multiple controllers 212 may be connected, with each device providing portions of the necessary operations to enable the functions of the system 200. In some embodiments, the processor 238 may include the acquisition unit 234, the light detector control unit 232, the light source control unit 230, and/or the processing unit 236.

[0247] As used herein, a processor such as the processor 238 may include any programmable system including systems using micro-controllers, reduced instruction set circuits (RISC), application specific integrated circuits (ASICs), logic circuits, and any other circuit or processor capable of executing the functions described herein. The above examples are example only, and are thus not intended to limit in any way the definition and/or meaning of the term “processor.”

[0248] As described herein, computing devices and computer systems include a processor and a memory. However, any processor in a computer device referred to herein may also refer to one or more processors wherein the processor may be in one computing device or a plurality of computing devices acting in parallel. Additionally, any memory in a computer device referred to herein may also refer to one or more memories wherein the memories may be in one computing device or a plurality of computing devices acting in parallel.

## C. Operation Unit

[0249] The operation unit 214 may be configured to enable a user to interface (e.g., visual, audio, touch, button presses, stylus taps, etc.) with the controller 212 to control the operation of the system 200. In some embodiments, the operation unit 214 may be further coupled to each sensor head 204 to control the operation of each sensor head 204.

## D. Display Unit

[0250] Referring again to FIG. 2, the system 200 may further include a display unit 216 configured to enable a user to view data and control information of the system 200. The display unit 216 may further be coupled to other components of the system 200 such as the sensor head 204. The display unit 216 may include a visual display such as a cathode ray tube (CRT) display, liquid crystal display (LCD), light emitting diode (LED) display, or “electronic ink” display. In some embodiments, the display unit 216 may be configured to present a graphical user interface (e.g., a web browser and/or a client application) to the user. A graphical user interface may include, for example, an display for GFR values as described herein above as produced by the system 200, and operational data of the system 200

## Exogenous Markers

[0251] Without being limited to any particular theory, molecules which are highly hydrophilic and small (creatinine, molecular weight=113) to moderately sized (inulin, molecular weight ~5500) are known to be rapidly cleared

from systemic circulation by glomerular filtration. In addition to these properties, an ideal GFR agent would not be reabsorbed nor secreted by the renal tubule, would exhibit negligible binding to plasma proteins, and would have very low toxicity. In order to design optical probes that satisfy all of these requirements a balance was struck between photophysical properties, and the molecular size and hydrophilicity of the fluorophore. For example, while hydrophobic cyanine and indocyanine dyes absorb and emit optimally within the near infrared (NIR) biological window (700-900 nm), hydrophilicity is not sufficiently high to function as pure GFR agents. Smaller dye molecules may be more easily converted to the extremely hydrophilic species required for renal clearance, but the limited x-systems resulting from these lower molecular weight compounds generally enable one photon excitation and emission in the ultraviolet (UV).

[0252] To resolve the pharmacokinetic issues in concert with enhancing the photophysical properties, simple derivatives of 2,5-diaminopyrazine-3,6-dicarboxylic acid act as very low molecular weight fluorescent scaffold systems with bright emission in the yellow-to-red region of the electromagnetic spectrum. SAR studies have been carried out using amide-linked variants of these derivatives for the simultaneous optimization of GFR pharmacokinetics and photophysical properties. A variety of hydrophilic functionalities for enabling rapid renal clearance of this class of pyrazine fluorophores including carbohydrate, alcohol, amino acid and various PEG-based linker strategies may be employed. PEG substitution maybe used to increase hydrophilicity and solubility, reduce toxicity, and modulate aggregation of the resulting pyrazine derivatives. Variations of molecular weight and architecture (and hence hydrodynamic volume) in a series of moderately sized PEG-pyrazine derivatives may also be suitable for use as endogenous fluorescent agents.

[0253] In one aspect, the exogenous fluorescent agent is MB-102.

## EXAMPLES

[0254] The following example illustrates various aspects of the disclosed systems and methods.

### Example 1: Perturbation Analysis

[0255] To demonstrate the effectiveness of the diffuse reflectance data correction method described herein above, the following experiments were conducted.

[0256] A system similar to the system 200 described herein above was used to monitor the fluorescence produced during the renal elimination of an exogenous fluorescent agent, MB-102, using the methods described herein above, in particular the diffuse reflectance data correction method.

[0257] FIG. 21A is a graph summarizing the changes in the magnitude of the raw fluorescence signal (Flr) just prior to injection of the MB-102 fluorescent agent into a pig and for about six hours post-injection. During the post-equilibration portion, corresponding to a time of about 13:45 in FIG. 21A, the pig was subjected to a series of perturbations selected to vary the optical properties of the pig's skin and/or underlying tissues: administration of blood pressure medications to induce vasodilation/vasoconstriction 2102, application of pressure to compress the tissue 2104, lateral

movement of the sensor head 2106, SpO<sub>2</sub> decrease 2108, SpO<sub>2</sub> decrease 2110, remove/replace sensor head 2112/2114, and skin cooling 2116.

[0258] FIG. 21B is a graph summarizing the corrected intrinsic fluorescence signal (IF) corrected as described herein above with no baseline subtraction. At time points later than 2 hours after agent injection, the time course of the IF signal was characterized by the expected single-exponential decay of the signal, with attenuated variation due to the applied perturbations.

[0259] Table 4 summarizes the specific effects of the diffuse reflectance data correction method on the Flr data associated with each individual perturbation:

TABLE 4

Effect of Diffuse Reflectance Data Correction	
PERTURBATION	EFFECT OF CORRECTION
Pressure Application	Decreased data excursions/outliers
Lateral Sensor Movement	Decreased data excursions/outliers
SpO <sub>2</sub> Decrease	Slope of IF signal decrease improved
SpO <sub>2</sub> Increase	Slope of IF signal decrease improved
Remove/Replace Sensor Head	Decreased data excursions/outliers
Cooling	No noticeable impact

[0260] FIG. 21C is a graph summarizing the detected diffuse reflectance signals DR<sub>em,filtered</sub>, DR<sub>em</sub>, and DR<sub>ex</sub> substituted into Eqn. (20) to determine the diffuse reflectance correction of the raw Flr signal as described herein above. As illustrated in FIG. 21C, the DR<sub>em</sub>, filtered signal was the most sensitive to the various perturbations. The DR<sub>em</sub>, and DR<sub>ex</sub> signals exhibited modest variation in response to the perturbations.

[0261] The results of these experiments demonstrated that the diffuse reflectance data correction was capable of correcting the raw fluorescent signal data to compensate for the effects of a variety of perturbations that induced a variety of changes in the skin's optical properties.

### Example 2: Sensor Head with Flared Housing

[0262] FIG. 23 is a perspective view of a sensor head 204a in another aspect. In this other aspect, the sensor head 204a includes a housing 600a formed from an upper housing 602a and a flared lower housing 604a. The surface area of the lower housing 604a expands to form an enlarged bottom surface 608a. The housing 600a further includes a cable opening 806a formed through the upper housing 602a.

[0263] FIG. 24 is a bottom view of the sensor head 204a showing the bottom surface 608a of the housing 600a. The bottom surface 608a may include an aperture plate 702a including one or more apertures 704a configured to transmit light between the skin of the patient and the light sources and light detectors contained inside the housing 600. As illustrated in FIG. 24, the apertures 704a include a light delivery aperture 1002a configured to deliver illumination produced by the first and second light sources 218/220 to tissues of the patient 202, as well as first and second detector apertures 1004/1006 configured to receive light from the tissues of the patient 202. In one aspect, the bottom surface 608a enables the positioning of the apertures 704a beneath a relatively large area obscured from ambient light conditions by the bottom surface 608a. This reduction of scattered ambient light entering the first and second detector apertures 1004/

**1006** reduces noise introduced into the light intensity measurements obtained by the first and second light detectors **222/224**.

[**0264**] In various aspects, the bottom surface **608a** of the housing **600a** may be attached to the patient's skin using a biocompatible and transparent adhesive material **610a** including, but not limited to, a clear double-sided medical grade adhesive, as illustrated in FIG. **24**. The transparent adhesive material **610a** may be positioned on the bottom surface **608a** such that the adhesive material **610a** covers the apertures **704a**.

[**0265**] FIG. **25** is an isometric view of the sensor head **204a** with the upper housing **602a** and various electrical components removed to expose an inner housing **2502**. FIG. **26** is an exploded view of the inner housing **2502** and associated electrical components illustrated in FIG. **25**. Referring to FIG. **25** and FIG. **26**, the inner housing **2502** is contained within the housing **600a** and is mounted to the lower housing **608a**. The inner housing **2502** contains a sensor mount **912** with a first detection well **908**, a second detection well **910**, and a light source well **902** formed therethrough. The first light detector **222** is mounted within the first detection well **908** and the second light detector **224** is mounted within the second detection well **910**. The first and second light sources **218/220** are mounted within the light source well **902**. In an aspect, the first detection well **908**, second detection well **910**, and light source well **902** of the sensor mount **912** are optically isolated from one another to ensure that light from the light sources **218/220** does not reach the light detectors **222/224** without coupling through the skin of the patient **202**. The separation between the two detection wells **908/910** ensures that the detected fluorescence signal from the exogenous fluorescent agent is distinguishable from the unfiltered excitation light, as described in detail above.

[**0266**] Referring to FIG. **26**, the inner housing **2502** includes a first detection aperture **2602**, second detection aperture **2604**, and light source aperture **2606**. The sensor mount **912** is coupled to the inner housing **2502** so that the first detection aperture **2602**, second detection aperture **2604**, and light source aperture **2606** are aligned with the first detection well **908**, second detection well **910**, and light source well **902** of the sensor mount **912**, respectively.

[**0267**] In one aspect, optically transparent windows **2610**, **2612**, and **2614** are coupled within first detection aperture **2602**, second detection aperture **2604**, and light source aperture **2606**, respectively, to seal the apertures while also providing optically transparent conduits between the tissues and the interior of the sensor head **204a**. In addition, diffusers **2616**, **2618**, and **2620** are coupled over optically transparent windows **2610**, **2612**, and **2614**, respectively. The diffusers **2616**, **2618**, and **2620** are provided to spatially homogenize light delivered to the tissues by light sources **218/220** and to spatially homogenize light detected by light detectors **222/224**. In an aspect, the absorption filter **244** is coupled to the diffuser **2616**. In one aspect, an optically transparent adhesive is used to couple the absorption filter **244** is coupled to the diffuser **2616**.

[**0268**] In view of the above, it will be seen that the several advantages of the disclosure are achieved and other advantageous results attained. As various changes could be made in the above methods and systems without departing from the scope of the disclosure, it is intended that all matter

contained in the above description and shown in the accompanying drawings shall be interpreted as illustrative and not in a limiting sense.

[**0269**] When introducing elements of the present disclosure or the various versions, embodiment(s) or aspects thereof, the articles "a", "an", "the" and "said" are intended to mean that there are one or more of the elements. The terms "comprising", "including" and "having" are intended to be inclusive and mean that there may be additional elements other than the listed elements.

What is claimed is:

1. A system for displaying a measurement of renal function in a patient in real time, the system comprising:
  - a controller configured to obtain a measurement data set comprising a plurality of measurement data entries from at least one sensor head positioned on the patient and to transform the measurement data set into the measurement of renal function comprising:
    - an acquisition unit configured to receive the plurality of measurement data entries including at least two measurements, a measurement of the plurality of measurement data entries corresponding to a signal of a plurality of signals detected at a particular region by the at least one sensor head;
    - a processing unit configured to apply corrections to the plurality of measurement data entries and to transform a portion of the corrected plurality of measurement data entries into the measurement of renal function, comprising:
      - a post-agent administration selection subunit configured to identify a post-equilibration portion of the measurement data set; and
      - an RDTC calculation subunit configured to transform the corrected plurality of measurement data entries obtained over the post-equilibration portion of the measurement data set to calculate the measurement of renal function of the patient;
    - a display unit configured to display the measurement of renal function provided by the RDTC calculation subunit.
  2. The system of claim 1, wherein the post-agent administration selection subunit is further configured to identify and signal the post-equilibration portion to the RDTC calculation subunit.
  3. The system of claim 1, wherein the RDTC calculation subunit calculates an RDTC and converts RDTC into a Glomerular Filtration Rate (GFR) corrected for body size to quantify the renal function of the patient.
  4. The system of claim 3, wherein the body size metric is body surface area.
  5. The system of claim 3, wherein the body size metric is volume of distribution.
  6. The system of claim 3, wherein the RDTC calculation subunit is configured to provide the calculated RDTC in a format comprising: a graph of RDTC as a function of time, a single discrete RDTC value, a table of RDTC values as a function of time, a color-coded display or other graphical representation configured to specify whether the calculated RDTC may be classified as normal/healthy, abnormal, high, low, and any other suitable classification.
  7. The system of claim 6, wherein the format is continuously or non-continuously updated.

8. The system of claim 3, wherein the RDTC calculation subunit is configured to calculate RDTC within non-overlapping and overlapping windows within the measurement data set.

9. The system of claim 3, wherein the display unit comprises a graphical user interface that displays GFR as the measurement of renal function.

10. The system of claim 1, wherein the controller further comprises a light source control unit configured to operate at least one light source of the at least one sensor head.

11. The system of claim 1, wherein the controller further comprises a light detector control unit configured to operate at least one light detector of the at least one sensor head.

12. The system of claim 1, wherein the processing unit further comprises a pre-processing subunit configured to process the plurality of measurement data entries received from the at least one sensor head to remove one or more measurement errors.

13. The system of claim 12, wherein the pre-processing subunit comprises a tissue heterogeneity correction module

configured to enable a correction to variations in the detected plurality of signals associated with heterogeneity of tissues of the patient.

14. The system of claim 1, wherein the processing unit further comprises a baseline subtraction subunit configured to subtract a baseline signal from the plurality of measurement data entries to correct for the effects of autofluorescence and light leakage.

15. The system of claim 1, wherein the processing unit further comprises a fault detection subunit configured to monitor a magnitude of the plurality of measurement data entries to detect a malfunction of the system.

16. The system of claim 15, wherein the fault detection subunit is configured to inform of any irregularities of any detected malfunctions within the system via the display unit.

17. The system of claim 1, wherein the processing unit further comprises a diffuse reflectance correction subunit configured to remove effects of changes to optical properties of tissues of the patient from the plurality of measurement data entries.

\* \* \* \* \*