



US 20230286736A1

(19) **United States**

(12) **Patent Application Publication** (10) **Pub. No.: US 2023/0286736 A1**

Datta Roy

(43) **Pub. Date: Sep. 14, 2023**

(54) **ROOF RAIL FOR A PORTABLE STORAGE CONTAINER**

(52) **U.S. Cl.**
CPC **B65D 90/08** (2013.01); **B65D 88/12** (2013.01)

(71) Applicant: **Lodestar Quality LLC**, Lafayette, IN (US)

(57) **ABSTRACT**

(72) Inventor: **Prasenjit Datta Roy**, West Lafayette, IN (US)

A portable storage container includes a plurality of upstanding sidewalls defining a storage space therebetween such that the sidewalls are disposed in an outward direction from the storage space. A roof sheet is disposed above the sidewalls. At least one roof rail is connected to a corresponding one of the sidewalls. The roof rail includes a horizontal portion defining a first plane that is horizontally oriented, and a down-sloping portion attached to an outer edge of the horizontal portion. The down-sloping portion extends in an outward direction away from the horizontal portion and defines a second plane oriented at an angle of approximately between ten degrees and eighty degrees relative to the first plane. At least one fastener attaches the roof sheet to a corresponding down-sloping portion of a corresponding roof rail. The fastener extends through the roof sheet.

(21) Appl. No.: **18/198,333**

(22) Filed: **May 17, 2023**

Related U.S. Application Data

(63) Continuation-in-part of application No. 16/865,322, filed on May 2, 2020.

Publication Classification

(51) **Int. Cl.**
B65D 90/08 (2006.01)
B65D 88/12 (2006.01)

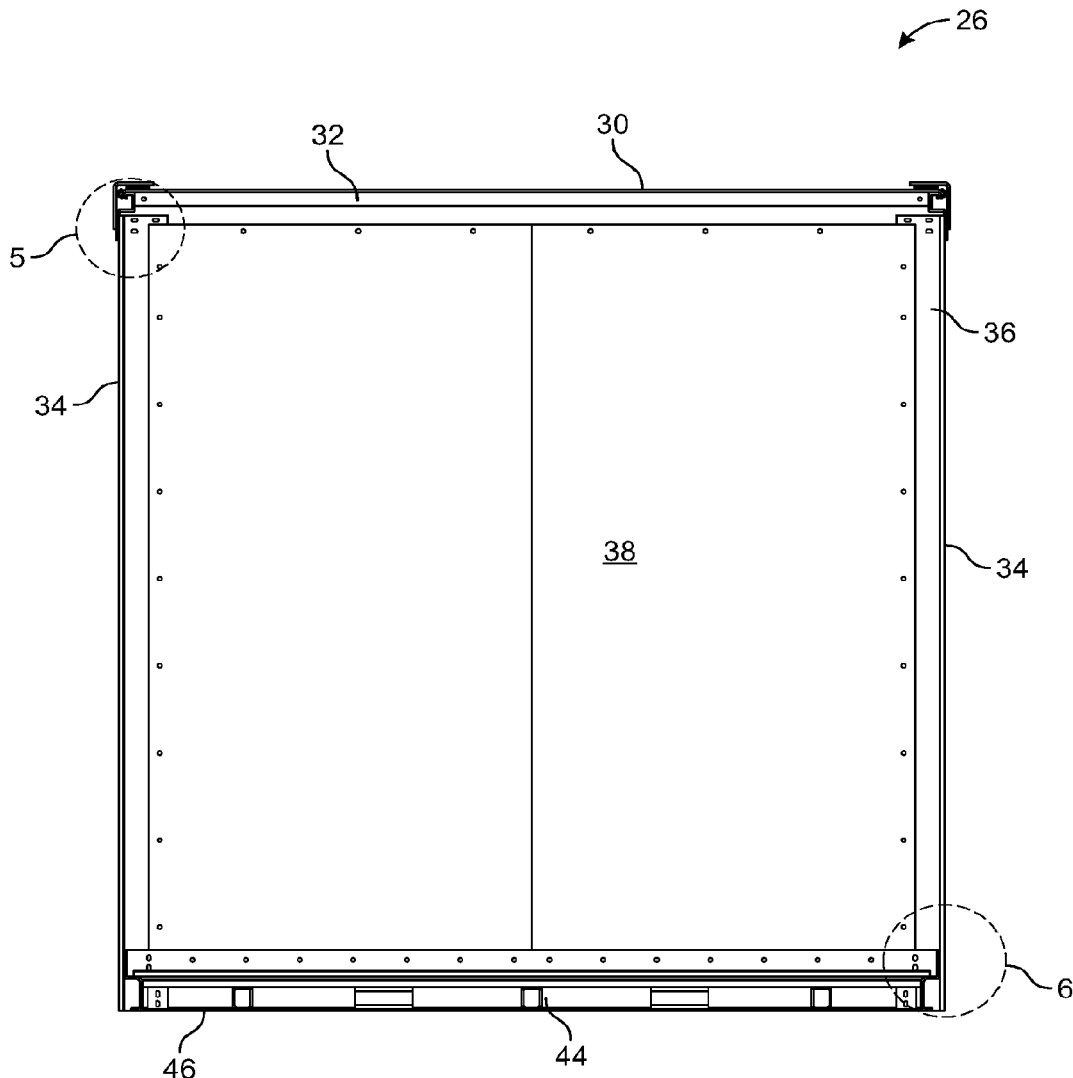

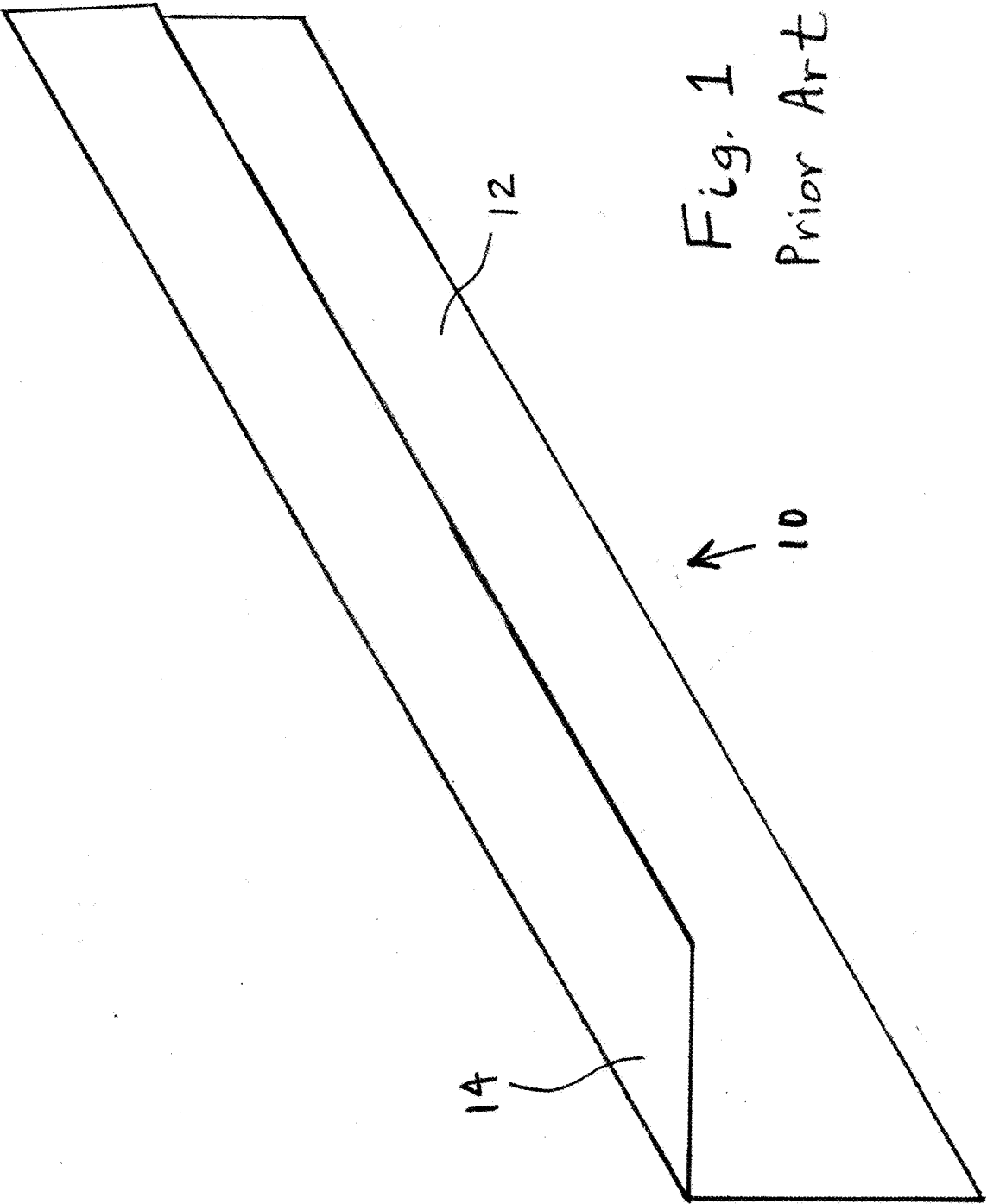

Fig. 1
Prior Art

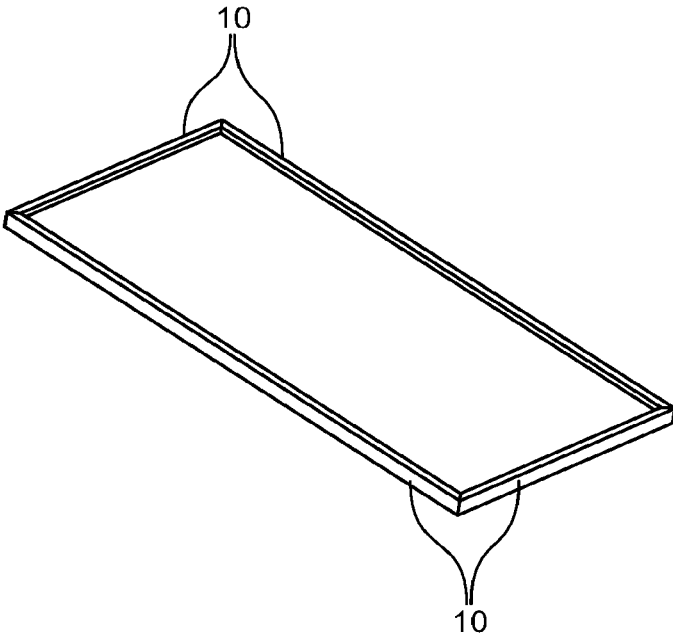

FIG. 2
(PRIOR ART)

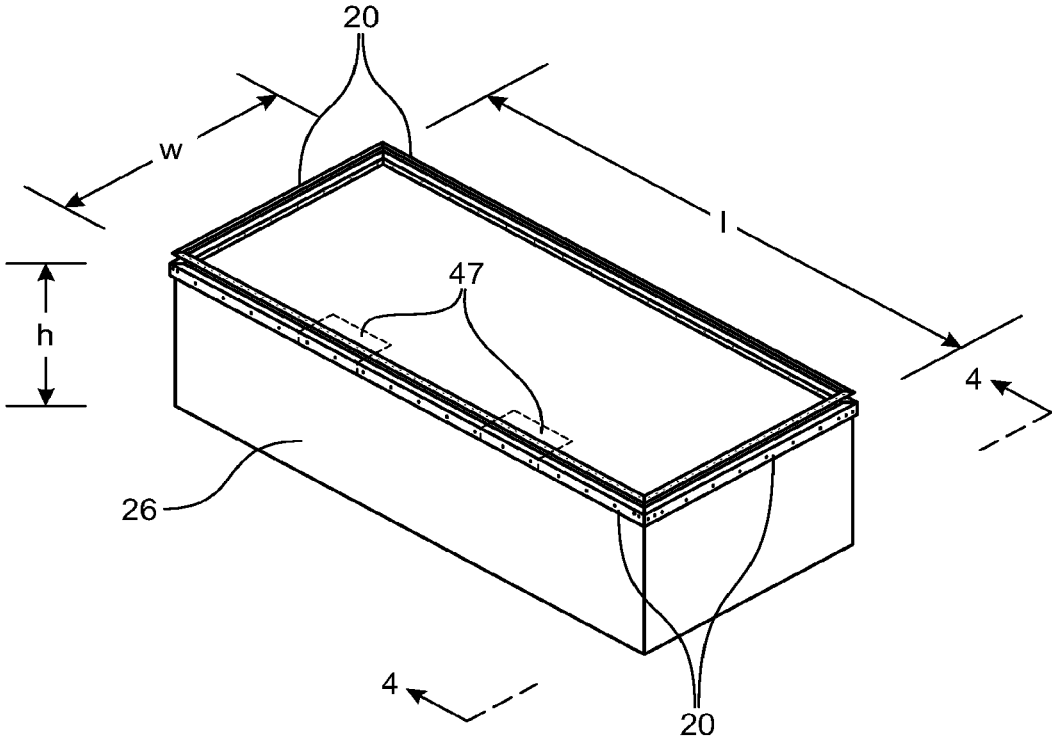

FIG. 3

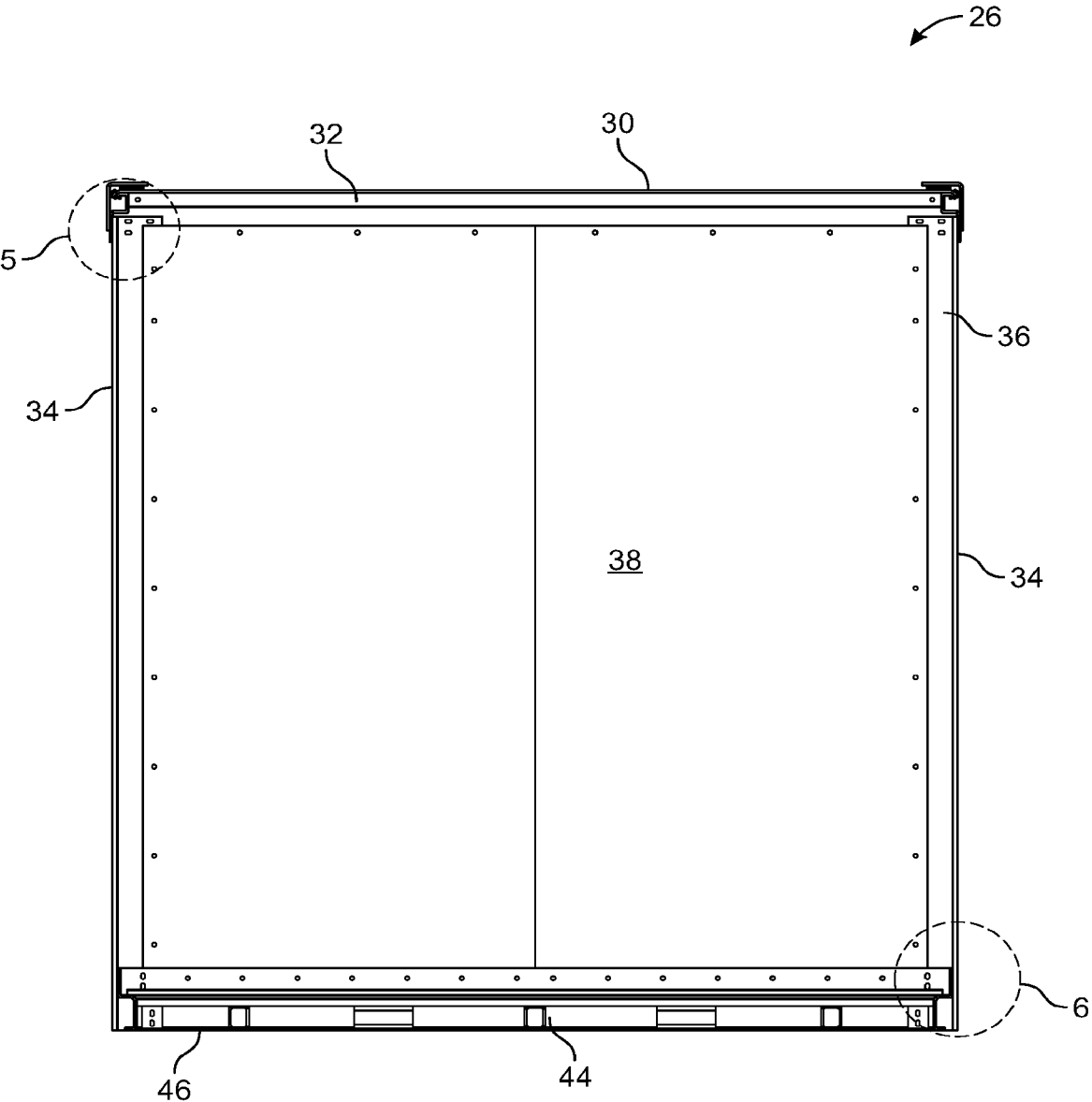

FIG. 4

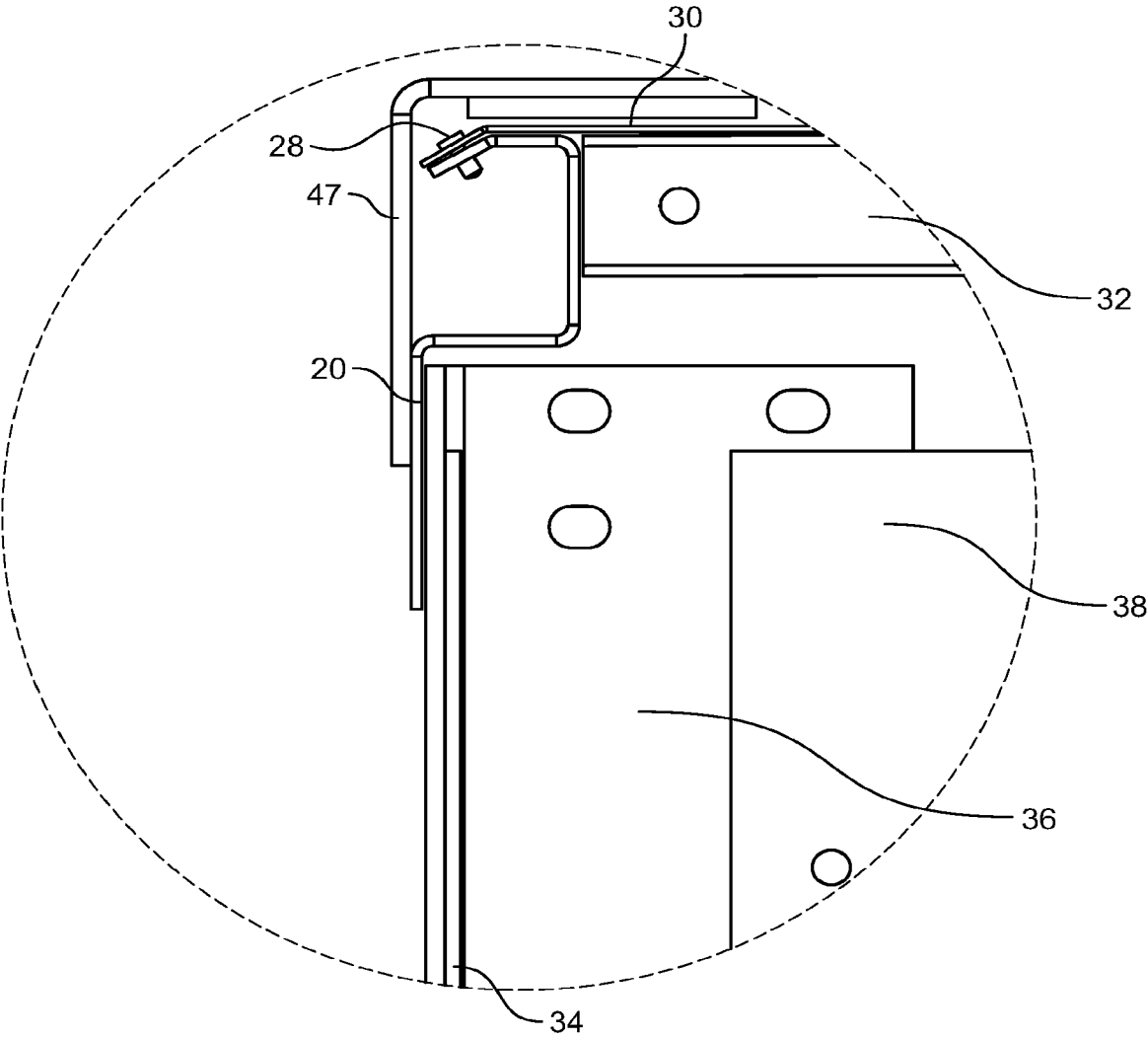

FIG. 5

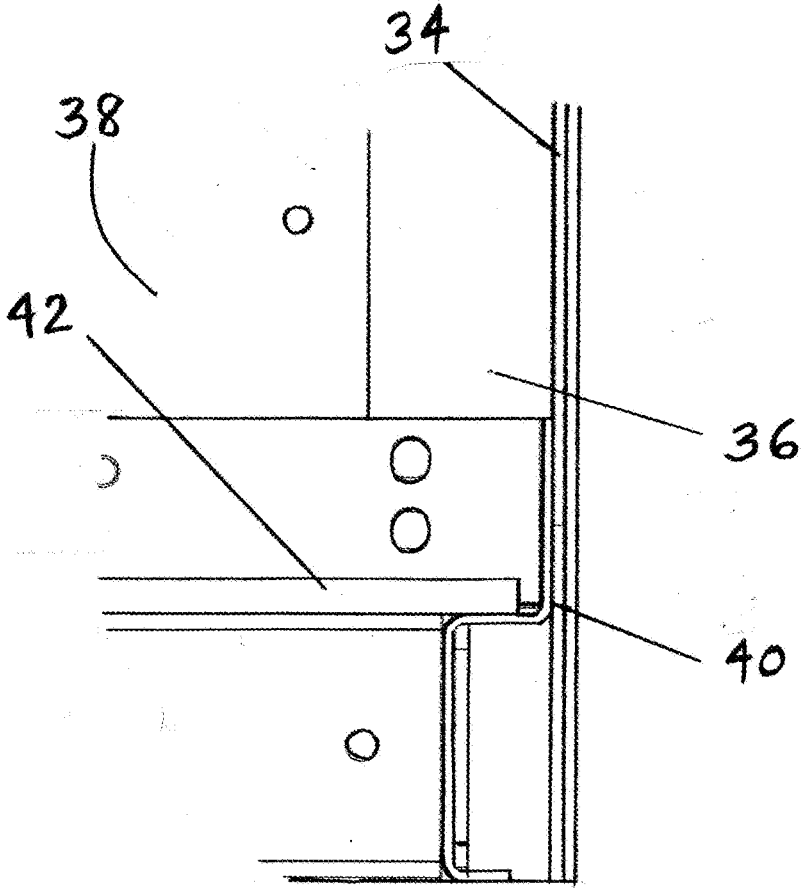
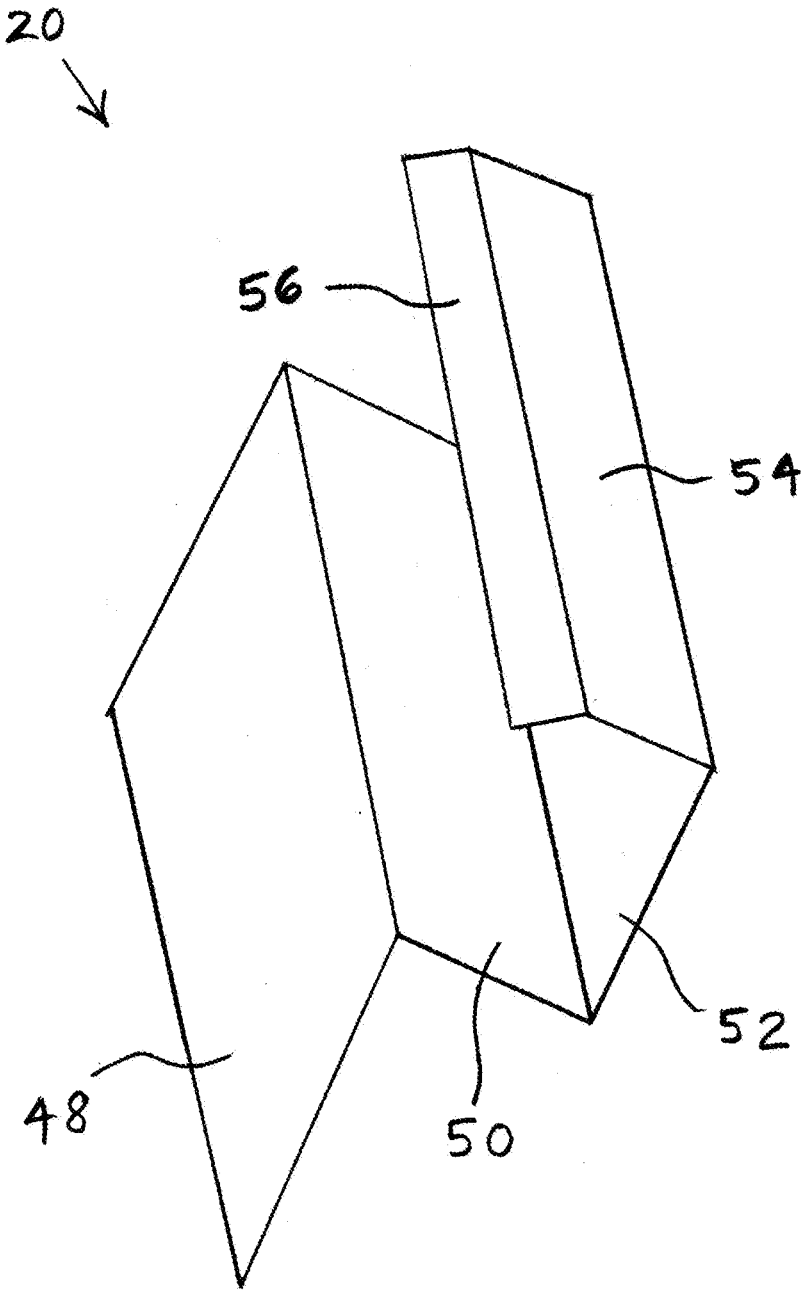

Fig. 6

Fig. 7



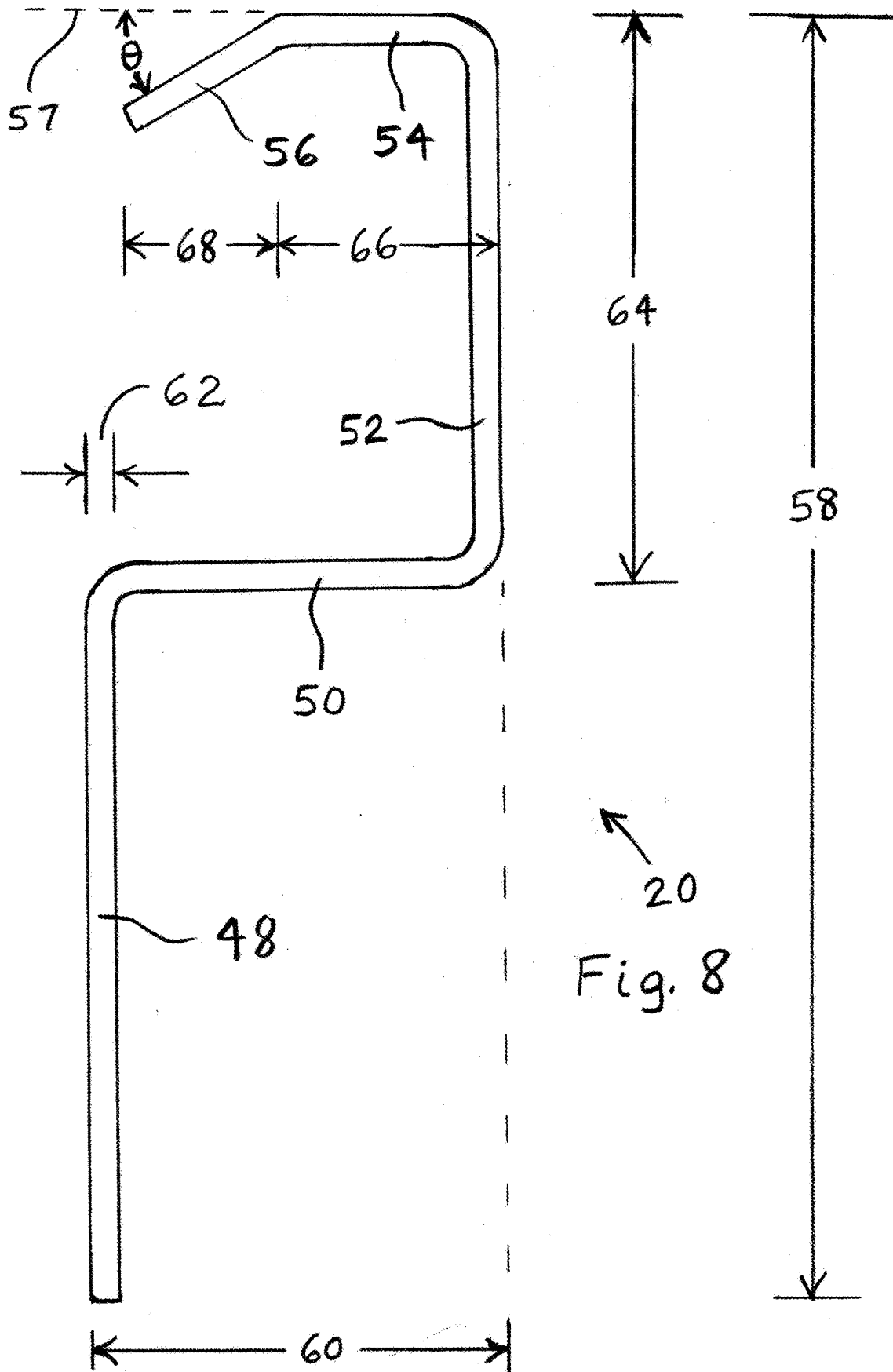

Fig. 8

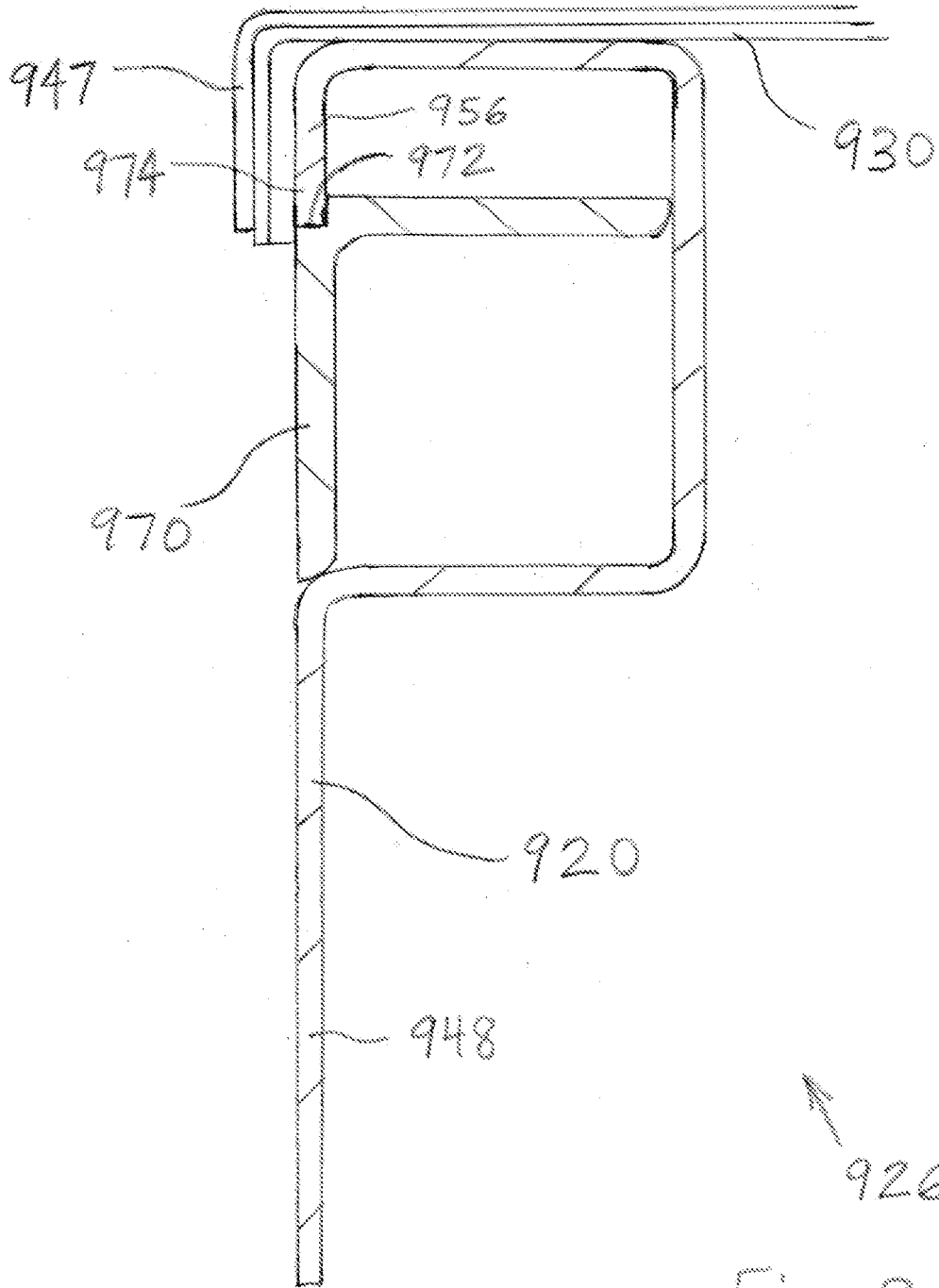

Fig. 9

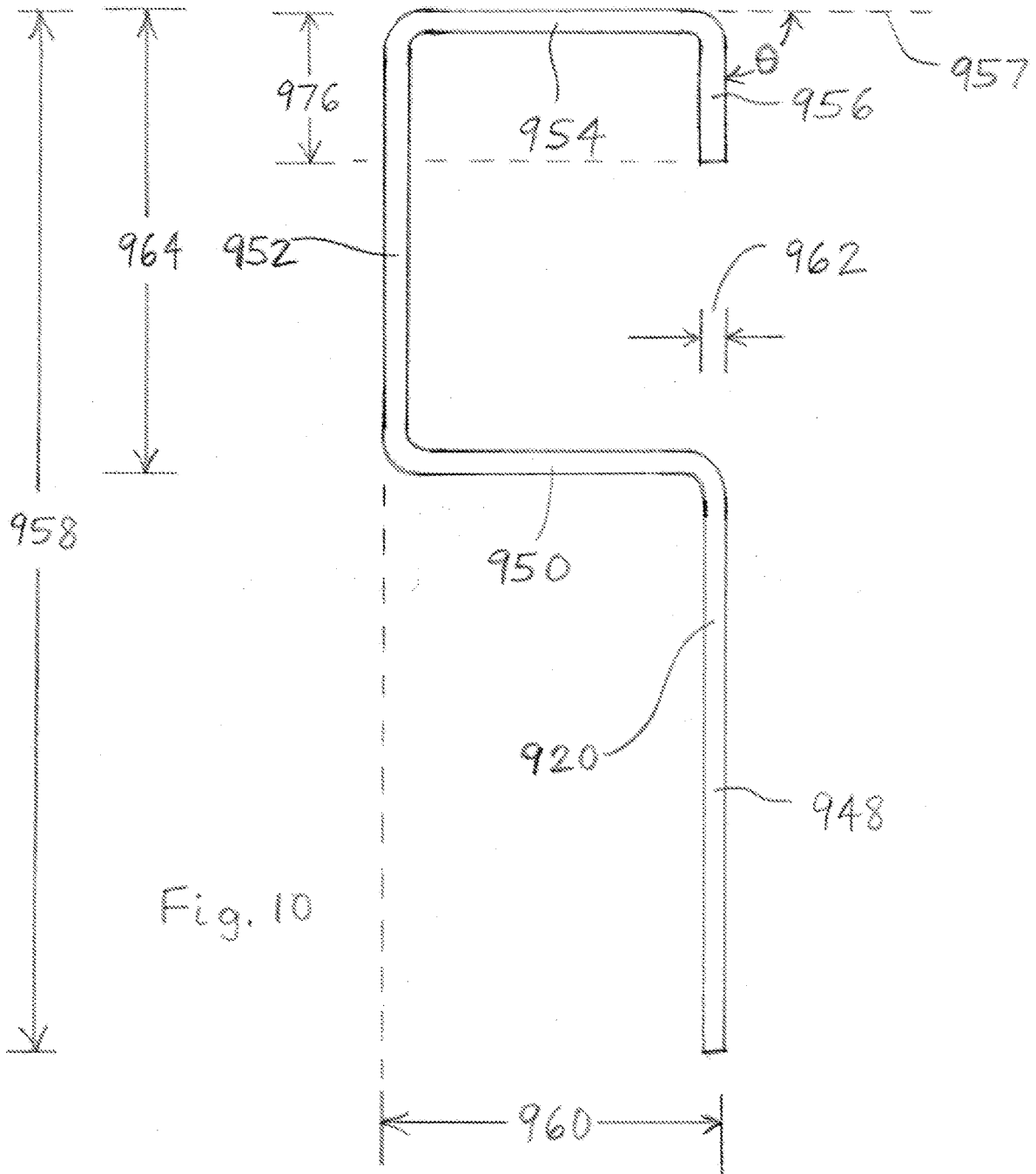

Fig. 10

ROOF RAIL FOR A PORTABLE STORAGE CONTAINER

CROSS-REFERENCED TO RELATED APPLICATIONS

[0001] This application is a continuation-in-part of U.S. patent application Ser. No. 16/865,322, filed on May 2, 2020, the disclosure of which is hereby incorporated by reference in its entirety for all purposes.

BACKGROUND

[0002] The present invention relates to a roof for a portable storage container. Such storage containers are frequently placed outdoors where they are exposed to rain, and thus the roofs of the containers need to be fully waterproof in order to prevent water damage to the contents of the container. FIG. 1 illustrates a portion of a rail 10 that extends along one of the edges of the rectangular top of the container. A similar rail 10 extends along each of the other three edges of the rectangular top of the container, as shown in FIG. 2. Each rail 10 includes a vertically-oriented portion 12 attached to a horizontally-oriented portion 14. A roof sheet (not shown) may be disposed above rails 10 and may be riveted to each horizontally-oriented portion 14. A silicone-based sealant is typically applied to the rivet joints in order to make the joints waterproof. However, the sealant degrades with age, which makes it difficult to maintain the rivet joints in a waterproof state. Further, often due to workmanship errors, there is often too much spacing between rivets, or rivets are missed, in which case the sealant cannot adequately cover the gap, which leads to water leaks.

SUMMARY

[0003] The present invention may include a roof rail having a down-sloping upper surface to which a roof sheet may be riveted. The down-sloping surface enables any water near the rivet joint to drain down away from the joint by force of gravity. Like the topside, the underside of the rivet joint is exposed to ambient air and is on a downslope to facilitate drainage and evaporation of any moisture near the rivet joint.

[0004] The invention comprises, in one form thereof, a portable storage container including a plurality of upstanding sidewalls defining a storage space therebetween such that the sidewalls are disposed in an outward direction from the storage space. A roof sheet is disposed above the sidewalls. At least one roof rail is connected to a corresponding one of the sidewalls. The roof rail includes a horizontal portion defining a first plane that is horizontally oriented, and a down-sloping portion attached to an outer edge of the horizontal portion. The down-sloping portion extends in an outward direction away from the horizontal portion and defines a second plane oriented at an angle of approximately between ten degrees and eighty degrees relative to the first plane. At least one fastener attaches the roof sheet to a corresponding down-sloping portion of a corresponding roof rail. Such fasteners extend through the roof sheet.

[0005] The invention comprises, in another form thereof, a roof rail for interconnecting a roof sheet and an upstanding sidewall of a portable storage container. The roof rail includes a cap portion including a first edge and a second

edge. The cap portion defines a first plane and is horizontally oriented while supporting a body of the roof sheet. A brim portion of the roof rail is attached to the first edge of the cap portion. The brim portion defines a second plane oriented at an angle of approximately between ten degrees and eighty degrees relative to the first plane. The brim portion is fastened to an outer periphery of the roof sheet while the brim portion slopes downward from the cap portion and while the cap portion is horizontally oriented and supports the body of the roof sheet. A leg portion is connected to the second edge of the cap portion. The leg portion is oriented perpendicular to the cap portion. The leg portion is attached to the upstanding sidewall of the portable storage container.

[0006] The invention comprises, in yet another form thereof, a method of installing a roof sheet on a portable storage container, including attaching a roof rail to one of a plurality of upstanding sidewalls that define a storage space therebetween such that the sidewalls are disposed outwardly from the storage space. A roof sheet is placed above the upstanding sidewalls such that a horizontal portion of the roof rail supports a body of the roof sheet. A periphery of the roof sheet is fastened to a down-sloping portion of the roof rail. The down-sloping portion extends outwardly and downwardly from an outer edge of the horizontal portion. A first plane defined by the horizontal portion is oriented at an angle of approximately between ten degrees and eighty degrees relative to a second plane defined by the down-sloping portion.

[0007] An advantage of the present invention is that water may drain away from the rivet joints that attach the roof sheet to the container.

[0008] Another advantage of the present invention is that waterproofing may be achieved without using sealant on the rivet joints that attach the roof sheet to the container.

[0009] Yet another advantage of the present invention is that even if there is workmanship error during riveting the roof is still waterproof.

BRIEF DESCRIPTION OF THE DRAWINGS

[0010] The above mentioned and other features and objects of this invention, and the manner of attaining them, will become more apparent and the invention itself will be better understood by reference to the following description of an embodiment of the invention taken in conjunction with the accompanying drawings, wherein:

[0011] FIG. 1 is a perspective view of a roof rail of the prior art;

[0012] FIG. 2 is a perspective view of four roof rails of the prior art in their relative positions as when they are attached to the rectangular top of a portable storage container;

[0013] FIG. 3 is a rear perspective view of one embodiment of a portable storage container of the present invention including four roof rails attached to the rectangular top of the portable storage container;

[0014] FIG. 4 is a rear view of the portable storage container of FIG. 3 along line 4-4;

[0015] FIG. 5 is an enlarged view of area 5 in FIG. 4;

[0016] FIG. 6 is an enlarged view of area 6 in FIG. 4;

[0017] FIG. 7 is a fragmentary perspective view of one of the roof rails of FIG. 3; and

[0018] FIG. 8 is a side view of one of the roof rails of FIG. 3.

[0019] FIG. 9 is a rear view of an upper corner of another embodiment of a portable storage container of the present invention including another embodiment of a roof rail of the present invention.

[0020] FIG. 10 is a front view of the roof rail of FIG. 9.

[0021] Corresponding reference characters indicate corresponding parts throughout the several views. Although the drawings represent embodiments of the present invention, the drawings are not necessarily to scale and certain features may be exaggerated in order to better illustrate and explain the present invention. Although the exemplification set out herein illustrates embodiments of the invention, in several forms, the embodiments disclosed below are not intended to be exhaustive or to be construed as limiting the scope of the invention to the precise forms disclosed.

DETAILED DESCRIPTION

[0022] The embodiments hereinafter disclosed are not intended to be exhaustive or limit the invention to the precise forms disclosed in the following description. Rather the embodiments are chosen and described so that others skilled in the art may utilize its teachings.

[0023] Referring to the drawings, wherein like numerals indicate like elements, FIG. 3 illustrates one embodiment of four roof rails 20 of the present invention attached to the rectangular top of a portable storage container 26. In one embodiment, portable storage container 26 has a height h approximately between seven and eight feet, a width w approximately between seven and eight feet, and a length 1 approximately between eight and twenty feet.

[0024] FIG. 4 illustrates portable storage container 26 along line 4-4 of FIG. 3. Portable storage container 26 includes roof rails 20 (FIG. 5), rivet pins 28, a roof sheet 30, a roof sheet support tube 32, side panels 34, back posts 36, a rear wall 38, floor rails 40 (FIG. 6), wooden floor 42, a floor support 44 and a floor support tube 46.

[0025] Optional brackets 47 may be spaced along the lengths of roof rails 20, and each bracket 47 may be attached to both roof rail 20 and roof sheet 30. As shown in FIG. 3, brackets 47 do not cover most of the lengths of roof rails 20.

[0026] As shown in FIG. 7, roof rail 20 includes a vertically-oriented leg portion 48 which is attached to a horizontally-oriented base portion 50, which is attached to a vertically-oriented back portion 52, which is attached to a horizontally-oriented cap portion 54, which is attached to a down-sloping brim portion 56. Leg portions 48 may be attached or adhered to side panels 34. Back portions 52 may be attached or adhered to roof sheet support tubes 32.

[0027] As shown in FIG. 5, cap portion 54 may support a body of roof sheet 30. A periphery of roof sheet 30 may be attached to brim portion 56 by rivet pin 28. The body of roof sheet 30 may be inside of and surrounded by the periphery of roof sheet 30.

[0028] As shown in FIG. 8, brim portion 56 may be oriented at an angle of 150 degrees relative to cap portion 54. That is, brim portion 56 may be oriented at an angle θ of 30 degrees down from the horizontal plane 57 of cap portion 54. A height 58 of roof rail 20 may be about 135 millimeters (mm); a width 60 of roof rail 20 may be about 44 mm; a thickness 62 of roof rail 20 may be about 3 mm; a height 64 of back portion 52 may be about 60 mm; a width 66 of cap portion 54 may be about 23 mm; and a width 68 of brim portion 56 may be about 16 mm.

[0029] Although angle θ is shown as being about 30 degrees, angle θ may be approximately between 10 degrees and 80 degrees within the scope of the invention. An advantage of angle θ being less than 90 degrees is that the integrity of the galvanization coating (e.g., zinc) on a rail 20 made of steel or iron is easier to maintain the smaller angle θ is. Similarly, because the shape of roof sheet 30 at its outer edges may conform to the shape of the upper surfaces of cap portion 54 and brim portion 56, an advantage of angle θ being less than 90 degrees is that the integrity of a roof sheet 30 having any brittleness is easier to maintain the smaller angle θ is. Another advantage of angle θ being less than 90 degrees is that there may be less warping during galvanizing.

[0030] FIG. 9 illustrates a rear view of an upper corner of another embodiment of a portable storage container 926 of the present invention including another embodiment of a roof rail 920 of the present invention. Portable storage container 926 includes roof rails 920, a roof sheet 930 and an L-shaped seal 970. L-shaped seal 970 includes a right-angled notch 972 for snugly receiving a distal tip 974 of roof rail 920. Thus, L-shaped seal 970 may be securely snapped into place within roof rail 920 due to an interference fit, and may thereby provide a watertight seal to prevent water from entering roof rail 920.

[0031] Optional brackets 947 may be spaced along the lengths of roof rails 920, and each bracket 947 may be attached to roof sheet 930. Similarly to brackets 47, brackets 947 do not cover most of the lengths of roof rails 920.

[0032] FIG. 10 illustrates roof rail 920 of FIG. 9 from an opposite direction. Roof rail 920 includes a vertically-oriented leg portion 948 which is attached to a horizontally-oriented base portion 950, which is attached to a vertically-oriented back portion 952, which is attached to a horizontally-oriented cap portion 954, which is attached to a vertically-oriented brim portion 956. Leg portions 948 may be attached or adhered to side panels (not shown) of container 926, which may be similar to side panels 34 of container 26. Leg portions 948 may be coplanar with brim portion 956. Back portions 952 may be attached or adhered to roof sheet support tubes (not shown) of container 926, which may be similar to roof sheet support tubes 32 of container 26.

[0033] As shown in FIG. 9, cap portion 954 may support a body of roof sheet 930. A periphery of roof sheet 930 may be attached to brim portion 956 by rivet pins (not shown), adhered to brim portion 956, or may not be directly attached or adhered to brim portion 956 at all. The body of roof sheet 930 may be inside of and surrounded by the periphery of roof sheet 930.

[0034] Brim portion 956 may be oriented at an angle of 90 degrees relative to cap portion 954. That is, brim portion 956 may be oriented at an angle θ of 90 degrees down from the horizontal plane 957 of cap portion 954. A height 958 of roof rail 920 may be about 135 millimeters (mm); a width 960 of roof rail 920 may be about 44 mm; a thickness 962 of roof rail 920 may be about 3 mm; a height 964 of back portion 952 may be about 60 mm; and a height 976 of brim portion 956 may be about 20 mm. Although angle θ is shown as being about 90 degrees, angle θ may be approximately between 75 degrees and 105 degrees within the scope of the invention.

[0035] Other aspects and features of container **926** may be substantially similar to those of container **26**, and are not described in detail herein in order to avoid needless repetition.

[0036] While this invention has been described as having an exemplary design, the present invention may be further modified within the spirit and scope of this disclosure. This application is therefore intended to cover any variations, uses, or adaptations of the invention using its general principles. Further, this application is intended to cover such departures from the present disclosure as come within known or customary practice in the art to which this invention pertains.

What is claimed is:

1. A roof rail for interconnecting a roof sheet and an upstanding sidewall of a portable storage container, the roof rail comprising:

a cap portion including a first edge and a second edge, the cap portion defining a first plane and being configured to be horizontally oriented while supporting a body of the roof sheet;

a brim portion attached to the first edge of the cap portion, the brim portion defining a second plane oriented at an angle of approximately between seventy-five degrees and one hundred five degrees relative to the first plane, the brim portion being configured to be fastened to an outer periphery of the roof sheet while the brim portion extends downward from the cap portion and while the cap portion is horizontally oriented and supports the body of the roof sheet; and

a leg portion connected to the inner edge of the cap portion, the leg portion being oriented perpendicular to the cap portion, the leg portion being configured to be attached to the upstanding sidewall of the portable storage container.

2. The roof rail of claim **1**, wherein the brim portion is configured to be fastened to an outer periphery of the roof sheet by a fastener extending through both the roof sheet and the brim portion.

3. The roof rail of claim **1**, wherein the second plane is oriented at an angle of approximately between eighty-five degrees and ninety-five degrees relative to the first plane.

4. The roof rail of claim **1**, wherein the roof rail further comprises a back portion oriented perpendicular to the cap portion, a first edge of the back portion being attached to the second edge of the cap portion, the back portion being disposed below the cap portion while the cap portion is horizontally oriented and supports the body of the roof sheet.

5. The roof rail of claim **4**, wherein the roof rail further comprises a base portion attached to a second edge of the back portion and disposed outwardly of the back portion.

6. The roof rail of claim **5**, wherein the leg portion is attached to an outward edge of the base portion.

7. The roof rail of claim **1**, wherein the leg portion is substantially coplanar with the brim portion.

8. A roof rail for interconnecting a roof sheet and an upstanding sidewall of a portable storage container, the roof rail comprising:

a cap portion including an outer edge and an inner edge, the cap portion defining a first plane and being configured to be horizontally oriented while supporting a body of the roof sheet;

a brim portion attached to the outer edge of the cap portion, the brim portion defining a second plane ori-

ented at an angle of approximately between seventy degrees and one hundred ten degrees relative to the first plane, the brim portion being configured to be fastened to an outer periphery of the roof sheet while the brim portion extends downward from the cap portion and while the cap portion is horizontally oriented and supports the body of the roof sheet; and

a leg portion connected to the inner edge of the cap portion, the leg portion being oriented perpendicular to the cap portion, the leg portion being configured to be attached to the upstanding sidewall of the portable storage container.

9. The roof rail of claim **8**, wherein the brim portion is configured to be adhered to an outer periphery of the roof sheet.

10. The roof rail of claim **8**, wherein the second plane is oriented at an angle of approximately between eighty degrees and one hundred degrees relative to the first plane.

11. The roof rail of claim **8**, wherein the roof rail further comprises a back portion oriented perpendicular to the cap portion, a first edge of the back portion being attached to the inner edge of the cap portion, the back portion being disposed below the cap portion while the cap portion is horizontally oriented and supports the body of the roof sheet.

12. The roof rail of claim **11**, wherein the roof rail further comprises a base portion attached to a second edge of the back portion and disposed outwardly of the back portion.

13. The roof rail of claim **12**, wherein the leg portion is attached to an outward edge of the base portion.

14. The roof rail of claim **8**, wherein the leg portion is substantially coplanar with the brim portion.

15. A roof rail for interconnecting a roof sheet and an upstanding sidewall of a portable storage container, the roof rail comprising:

a cap portion including an outer edge and an inner edge, the cap portion defining a first plane and being configured to be horizontally oriented while supporting a body of the roof sheet;

a brim portion attached to the outer edge of the cap portion, the brim portion defining a second plane oriented at an angle of approximately between sixty-five degrees and one hundred fifteen degrees relative to the first plane, the brim portion being configured to be fastened to an outer periphery of the roof sheet while the brim portion extends downward from the cap portion and while the cap portion is horizontally oriented and supports the body of the roof sheet;

a middle portion having an upper end and a lower end, the upper end being attached to the inner edge of the cap portion; and

a leg portion connected to the lower end of the middle portion, the leg portion being attached to the upstanding sidewall of the portable storage container.

16. The roof rail of claim **15**, wherein the second plane is oriented at an angle of approximately ninety degrees relative to the first plane.

17. The roof rail of claim **15**, wherein the middle portion includes:

a back portion having a top edge attached to the inner edge of the cap portion, the back portion being disposed below the cap portion while the cap portion supports the body of the roof sheet; and

a base portion attached to a bottom edge of the back portion and disposed outwardly of the back portion.

18. The roof rail of claim **17**, wherein the leg portion is attached to an outer edge of the base portion.

19. The roof rail of claim **15**, wherein the brim portion is configured to be separated from an outer periphery of the roof sheet by a gap.

20. The roof rail of claim **15**, wherein the leg portion is substantially coplanar with the brim portion.

* * * * *