

(No Model.)

J. M. REAMS.
END GATE FASTENER.

No. 339,470.

Patented Apr. 6, 1886.

Fig. 1.

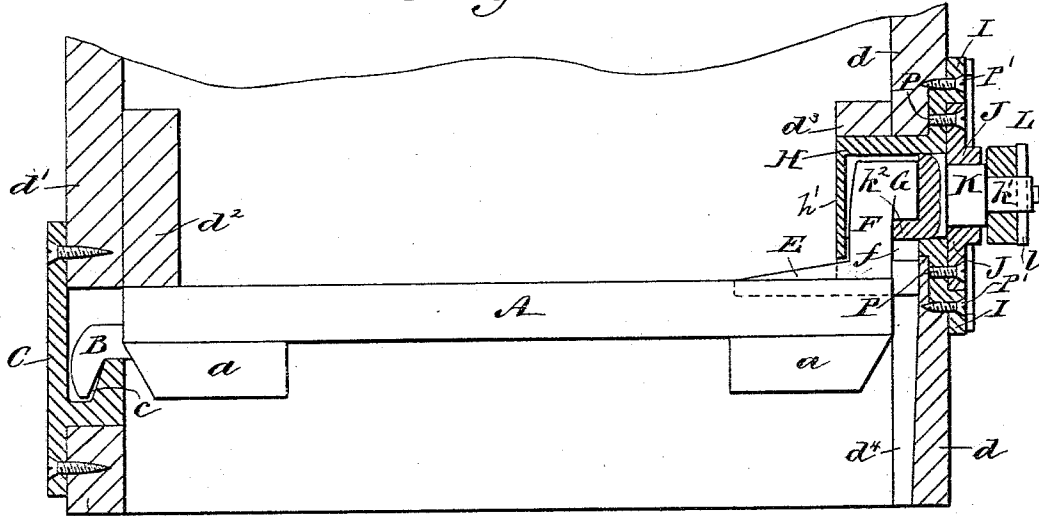

Fig. 2.

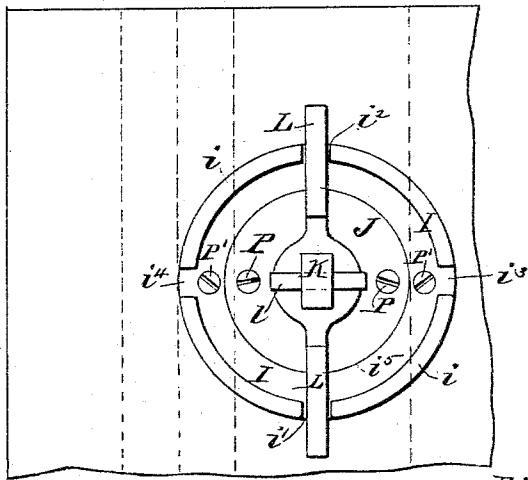

Fig. 9.

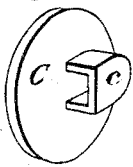

Fig. 8.

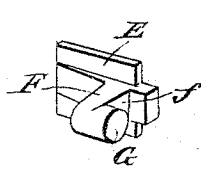

Fig. 7.



Fig. 3.

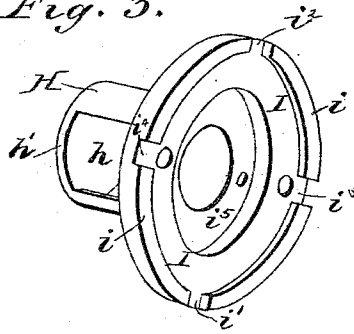
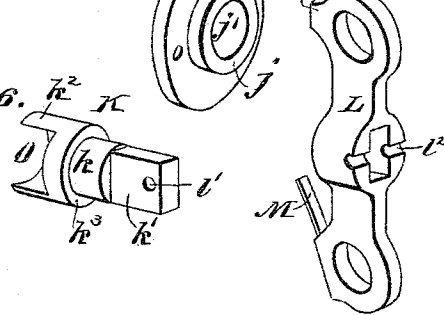

Fig. 4.

Fig. 5.



WITNESSES:

John H. Deemer
C. Sedgwick

INVENTOR:

J. M. Reams
BY *Munn & Co.*

ATTORNEYS.

UNITED STATES PATENT OFFICE.

JOSEPH M. REAMS, OF CURWENSVILLE, PENNSYLVANIA.

END-GATE FASTENER.

SPECIFICATION forming part of Letters Patent No. 339,470, dated April 6, 1886.

Application filed January 15, 1886. Serial No. 188,053. (No model.)

To all whom it may concern:

Be it known that I, JOSEPH MONROE REAMS, of Curwensville, in the county of Clearfield and State of Pennsylvania, have invented certain new and useful Improvements in End-Gate Fastenings, of which the following is a full, clear, and exact description.

My invention relates to devices for fastening the end-gates of wagons or other vehicles, and has for its object to provide simple, inexpensive, and effective fastenings, which may be quickly and easily operated to lock and unlock the end-gate, and may be applied readily to new or old vehicles.

The invention consists in certain novel features of construction and combinations of parts of the end-gate fastenings, all as hereinafter fully set forth.

Reference is to be had to the accompanying drawings, forming part of this specification, in which similar letters of reference indicate corresponding parts in all the figures.

Figure 1 is a sectional plan view showing a wagon-body in part, and with an end-gate secured thereto by my improved fastenings. Fig. 2 is a side elevation, and Figs. 3 to 9, inclusive, are detail views of parts of the end-gate fastenings, and will be hereinafter fully described.

The end-gate A preferably is provided with the strengthening cross-cleats *a a*, and at one end is fitted with a metal hook, B, which is adapted to enter a socket, *c*, formed at the inner face of a metal plate, C, which is shown in inside perspective view in Fig. 9, and is fixed to the left-hand side board, *d'*, of the wagon-body and whereby when that end of the gate A rests against the adjacent side cleat, *d''*, on the wagon-body, and the other end of the gate rests against the opposite cleat, *d''*, on the other side, *d*, of the wagon-body, the hook B and socket-plate C *c* will securely hold one end of the gate A, as seen in Fig. 1 of the drawings.

To the inside face of the end-gate A, next the cleat *d''*, of the wagon-body is fixed a plate, E, (see Fig. 8,) on which is a lug, F, which has a face slot, *f*, curved at one edge to leave at the inner end and outer face of the lug the round stud or boss G, which is adapted to enter an

opening, *h*, made in the side of a hollow collar or hub, H, fixed to a plate, I, (see Fig. 3,) and having a closed inner end, *h'*. A disk or plate, J, (see Fig. 4,) adapted to a face-recess, *i''*, in plate I, has a boss or collar, *j*, around its central hole, *j'*, in which is fitted the rounded part *k* of the shank of the locking-head K, (see Fig. 6,) on the outer rectangular end, *k'*, of which head is fitted loosely the button L. (Shown detached in Fig. 5.) A pin, *l*, passed through the hole *l'* in the end-part, *k'*, of the head K, and outside of the button L, holds the head within the plate J, and also holds the button onto the stem of the head.

The pin *l* enters a face notch or recess, *l''*, in the button L, and a spring, M, fixed to the button presses by its free end upon the boss or collar *j* of plate J, and thereby forces the stud N on the button into contact with a rim, *i*, at the face of the plate I, and said rim has notches *i' i' i' i'*, into any one of which the stud N may be forced and held by the spring.

The inner end of the locking-head K is formed as a hollow collar or with a flange, *k''*, open at the back end, and provided with a side slot, O, of sufficient width to allow the stud or boss G on the end-gate to be entered within the flange *k''*, when the slot O of said flange coincides with the side opening, *h*, of the hub H on plate I. The inner face of the flange *k''* is formed as a cam, which increases in eccentricity to a point directly opposite the center of the opening O, (see Fig. 7,) so it will draw the end-gate up tightly to the box-cleat *d''* by action on the boss G, when the head K is turned either to the right or left hand to the full locking position, as hereinafter described.

In assembling the parts the locking-head K will be passed into the hole *j'* of the plate J from the inside until the shoulder *k''* of the head strikes the back of the plate, and the plate then will be laid within the face-recess *i''* of plate I, and the screws or bolts P will hold the plates I J to each other, and other screws or bolts, P', will be used to hold the plates to the side *d* of the wagon-body. The button L now will be slipped onto the end *k'* of head K and the pin *l* inserted, and the locking device I H J K L is complete and fixed to the wagon-body, the cleat *d''* on which

has a suitable recess to admit the hub H of plate I. The side *d* of the wagon-body is grooved at *d'*, for the passage of the projecting end of the lug F, of which the boss G forms a part.

The operation is as follows: When the button L is adjusted with its stud N in the lower notch, *i'*, of plate I, the side opening, O, of head K will coincide with the side opening, *h*, of hub H, and when the end-gate is to be adjusted to the wagon, the hook B on the gate will be placed in the socket *c* of plate C, and the other end of the gate will be pushed in against the cleat *d'*, and the lug G will pass through the side opening, *h*, of hub H and the side opening, O, of head K, whereupon the button L will be disengaged from the notch *i'* of plate I, by pressing its upper end inward, and the head K then will be turned one-half way around by the button L, so that the stud N on the button engages the upper notch, *i''*, of plate I, which will have caused the flange *k''* of head K to be turned within the slot *f* of lug F and in front of the end-gate boss G, to draw the end-gate closely to the box-cleat *d'*, and lock the gate securely to place.

The boss G will be confined within the head K by the flange *k''*, should the stud N be locked within either of the notches *i'* *i''* of plate I, as the side openings, O *h*, of the fastening will then be out of line; but it is preferable to turn the head K one-half way around, as above described, in fastening the end-gate. The notches *i'* *i''* will confuse unauthorized persons, as they will be likely to set the stud N in either of these notches in attempting to loosen or remove the end-gate.

A fastening, G K, with connected parts, as above described, may be used at both ends of the gate, or two of these fastenings may be used at each end of a wide gate or a gate made in upper and lower sections, as will readily be understood.

Having thus described my invention, what I claim as new, and desire to secure by Letters Patent, is—

1. An end-gate fastening comprising a plate, E, provided with a stud, as at G, and fixed to the end-gate, a hub, H, having a side opening, *h*, and fixed to the wagon-body, a head, K, held in the hub H, and adapted to be rotated therein, and provided with a flange, *k''*, having a side opening, as at O, substantially as herein set forth.

2. An end-gate fastening comprising a plate, E, provided with a stud, G, and fixed to the end-gate, a hub, H, having a side opening, *h*, and fixed to the wagon-body, and a head, K, held loosely in hub H, and having a flange, *k''*, formed at its inner face as a cam, and provided with a side opening, O, substantially as herein shown and described, and for the purposes set forth.

3. The combination, in an end-gate fastening, of a plate, E, provided with a stud, G, and fixed to the end-gate, a plate, I, having notches *i'* *i''*, a hub, H, having a side opening, *h*, and fixed to the wagon-body, a head, K, held loosely in hub H, and having a flange, *k''*, provided with a side opening, O, and a spring-pressed button, L, fitted on head K, and having a stud, N, adapted to the notches of plate I, substantially as herein set forth.

4. The combination, in an end-gate fastening, of a plate, E, provided with a stud, G, and fixed to the end-gate, a plate, I, having a hub, H, provided with a side opening, *h*, and a closed inner end, *h'*, a head, K, held loosely in hub H, and having a flange, *k''*, provided with a side opening, O, and a plate, J, held to plate I, and on the shank of head K, substantially as and for the purposes herein set forth.

5. The combination, in an end-gate fastening, of a plate, E, provided with a stud, G, and fixed to the end-gate, a plate, I, notched at *i'* *i''*, a hub, H, having a side opening, *h*, and a closed inner end, *h'*, a head, K, held loosely in hub H, and having a flange, *k''*, provided with a side opening, O, a plate, J, held to plate I, and head K, a spring-pressed button, L, fitted on head K, and held by a pin, *l*, and having a stop, N, adapted to lock into the notches of plate I, substantially as herein set forth.

6. The combination, in an end-gate fastening, of a plate, C, having a socket, *c*, and fixed to one side of the wagon-body, a hook, B, on the end-gate, a plate, E, on the gate, and provided with a stud, G, a plate, I, on the wagon-body, and provided with a hub, H, having a side opening, *h*, a head, K, held loosely in hub H, and having a flange, *k''*, provided with a side opening, O, and means, substantially as described, for holding the head K to hub H, as and for the purposes herein set forth.

JOSEPH M. REAMS.

Witnesses:

JOHN H. NORRIS,
J. A. MAXWELL.