

(19)



(11)

EP 1 278 434 B1

(12)

EUROPEAN PATENT SPECIFICATION

(45) Date of publication and mention of the grant of the patent:
30.05.2007 Bulletin 2007/22

(51) Int Cl.:
A43B 13/20 (2006.01)

(21) Application number: **01924164.5**

(86) International application number:
PCT/US2001/008201

(22) Date of filing: **15.03.2001**

(87) International publication number:
WO 2001/070060 (27.09.2001 Gazette 2001/39)

(54) **BLADDER WITH MULTI-STAGE REGIONALIZED CUSHIONING**

BALG MIT MEHRSTUFIGEN DÄMPFUNGSGEBIETEN

COUSSIN AVEC AMORTISSEMENT LOCALISE A ETAGES MULTIPLES

(84) Designated Contracting States:
**AT BE CH CY DE DK ES FI FR GB GR IE IT LI LU
MC NL PT SE TR**

- **HERRIDGE, David, B.**
Mendota Heights, MN 55120 (US)
- **NAIMAN, Alaric, J.**
Lincoln, MA 01773 (US)
- **MACGREGOR, Alastair R.**
Cambridge CB2 2QS (GB)
- **SCARFE, Julian A.**
Cambridge CB2 2QS (GB)
- **AGER, Colin D.**
Cambridge CB2 2QS (GB)
- **COLBY, Edward G.**
Cambridge CB2 1GE (GB)

(30) Priority: **16.03.2000 US 526860**

(43) Date of publication of application:
29.01.2003 Bulletin 2003/05

(73) Proprietor: **NIKE INTERNATIONAL LTD**
Beaverton,
Oregon 97005-6453 (US)

(74) Representative: **Wenzel & Kalkoff**
Flasckuhle 6
58452 Witten (DE)

- (72) Inventors:
- **TAWNEY, John, C.**
Portland, OR 97225 (US)
 - **POTTER, Daniel, R.**
Forest Grove, OR 97116 (US)
 - **AVENI, Michael, A.**
Lake Oswego, OR 97035 (US)
 - **PASSKE, Joel, L.**
Hillsboro
OR 97123 (US)

(56) References cited:

EP-A- 0 893 074	US-A- 2 677 906
US-A- 4 999 931	US-A- 5 083 361
US-A- 5 979 086	US-A- 5 996 254

EP 1 278 434 B1

Note: Within nine months from the publication of the mention of the grant of the European patent, any person may give notice to the European Patent Office of opposition to the European patent granted. Notice of opposition shall be filed in a written reasoned statement. It shall not be deemed to have been filed until the opposition fee has been paid. (Art. 99(1) European Patent Convention).

Description

[0001] The present invention relates to an improved cushioning member for a shoe, and more particularly to a fluid filled bladder having multiple layers of chambers of varying pressures to provide regionalized cushioning to predetermined areas of the bladder and a method of forming an improved cushioning member with inverted seam lines along its sidewalls.

[0002] More particular the invention refers to a fluid-filled bladder for a shoe sole comprising:

an envelope formed of a first outer layer and a second outer layer of barrier film material sealed along their peripheries; and

a first inner layer and a second inner layer of barrier film material positioned between said first outer layer and said second outer layer,

- said inner layers dividing said envelope into a first fluid layer, a second fluid layer and a third fluid layer located between said first outer layer and said second outer layer,

- at least two of said fluid layers containing fluids with differing pressures.

[0003] Such bladder is known from US 5,996,254 as an inflatable insole system for placement in an article of footwear.

[0004] This known insole system has an inflatable flexible bottom cell which has a foot-shaped outer perimeter and which extends from a heel end to a toe end. A plurality of upwardly extending inflatable cells is arranged above the bottom cell and includes a heel middle cell, mid-foot middle cell, a toe middle cell, a heel upper cell, a mid-foot upper cell, and a toe upper cell. At least a portion of the cells are separately inflatable so that fluid and air may not pass between individual inflatable cells.

[0005] In those areas of the known insole where a middle cell and an upper cell is provided on the bottom cell, an envelope comprising three fluid layers is formed of barrier film material. The envelope is divided into a first fluid layer, a second fluid layer and a third fluid layer located between said first outer layer and said second outer layer. The second fluid layer corresponds to the middle cell and is formed by joining the edges of the first inner film layer to the second inner film layer which corresponds to the upper film layer of the bottom cell. And the first fluid layer corresponds to the toe upper cell and is positioned inside a chamber being formed by the first inner film layer and the first outer film layer. A method of making this known insole system is not disclosed in US 5,996,254.

[0006] Considerable work has been done to improve the construction of cushioning members which utilize fluid filled bladders such as those used in shoe soles. Although with recent developments in materials and manufacturing methods, fluid filled bladders have greatly improved in versatility, there remain problems associated

with obtaining optimum cushioning performance and durability. Fluid filled bladder members are commonly referred to as "air bladders," and the fluid is generally a gas which is commonly referred to as "air" without intending any limitation as to the actual gas composition used.

[0007] There are numerous conventional articles of footwear having gas filled cushioning devices in their midsole or outsole. Gas filled cushioning devices are typically referred to as "bladders" or "air bladders," and the gas is commonly referred to as "air" without intending any limitation as to the actual gas composition used. One well known type of bladder used in footwear is commonly referred to as a "two film bladder." These bladders include an outer shell formed by welding the peripheral edges of two symmetric pieces of a barrier material together. This results in the top, bottom and sidewalls of the bladder being formed of the same barrier material. If any one part of a two film bladder needs to be formed of a specific material and/or to a specific thickness, the entire bladder must be formed of that specific material and/or to that specific thickness. Forming a bladder from only two pieces of a barrier material prevents the side, top and bottom walls from being customized.

[0008] Closed-cell foam is often used as a cushioning material in shoe soles and ethylenevinyl acetate copolymer (EVA) foam is a common material. In many athletic shoes, the entire midsole is comprised of EVA- While EVA foam can easily be cut into desired shapes and contours, its cushioning characteristics are limited. One of the advantages of gas filled bladders is that gas as a cushioning compound is generally more energy efficient than closed-cell foam. This means that a shoe sole comprising a gas filled bladder provides superior cushioning response to loads than a shoe sole comprising only foam. Cushioning generally is improved when the cushioning component, for a given impact force, spreads the impact force over a longer period of time, resulting in a smaller impact force being transmitted to the wearer's body. Even when shoe soles comprising gas filled bladders include some foam, a reduction in the amount of foam will generally afford better cushioning characteristics.

[0009] The major engineering problems associated with the design of air bladders formed of barrier layers include: (i) obtaining complex-curved, contoured shapes without the formation of deep peaks and valleys in the cross section which require filling in or moderating with foams or plates; (ii) ensuring that the means employed to give the air bladder its complex-curved, contoured shape does not significantly compromise the cushioning benefits of air; (iii) providing regionalized cushioning to an air bladder to account for differences in load corresponding to the anatomical topology of a human foot especially during high loads; (iv) designing air bladders which maximize the cushioning properties of air and are made entirely of flat barrier films; and (v) designing bladders that provide the advantages of complex-contoured shapes and regionalized cushioning and which can be integrated easily into existing midsole manufacturing

methods.

[0010] The prior art is replete with attempts to address these difficulties, but have only solved one, two or even three of the above-described problems often presenting new obstacles in the process. Most of the prior art discloses some type of tensile member. A tensile member is an element associated with a bladder which ensures a fixed, resting relation between the top and bottom barrier layers when the bladder is fully filled, and which often is in a state of tension while acting as a restraining means to maintain the general external form of the bladder.

[0011] Some prior art constructions are composite structures of bladders containing foam or fabric tensile members. One type of such composite construction prior art concerns bladders employing an open-celled foam core as disclosed in U.S. Patent Nos. 4,874,640 and 5,235,715 to Donzis. These cushioning elements do provide latitude in their design in that the open-celled foam cores allow for complex-curved and contoured shapes of the bladder without deep peaks and valleys. However, bladders with foam core tensile member have the disadvantage of unreliable bonding of the core to the barrier layers. Another disadvantage of foam core bladders is that the foam core gives the bladder its shape and thus must necessarily function as a cushioning member which detracts from the superior cushioning properties of a gas alone. One reason for this is that in order to withstand the high inflation pressures associated with bladders, the foam core must be of a high strength which requires the use of a higher density foam. The higher the density of the foam; the less the amount of available volume in the bladder for a gas. Consequently, the reduction in the amount of gas in the bladder decreases the effectiveness of gas cushioning.

[0012] Even if a lower density foam is used, a significant amount of available volume is sacrificed which means that the deflection height of the bladder is reduced due to the presence of the foam, thus accelerating the effect of "bottoming out" Bottoming out refers to the premature failure of a cushioning device to adequately decelerate an impact load. Most cushioning devices used in footwear are non-linear compression based systems, increasing in stiffness as they are loaded. Bottoming out is the point where the cushioning system is unable to compress any further and is a common failure in shoe soles comprised of foam. Also, the elastic foam material itself performs a significant portion of the cushioning function and is subject to compression set. Compression set refers to the permanent compression of foam after repeated loads which greatly diminishes its cushioning aspects. In foam core bladders, compression set occurs due to the internal breakdown of cell walls under heavy cyclic compression loads such as walking or running. The walls of individual cells constituting the foam structure abrade and tear as they move against one another and fail. The breakdown of the foam exposes the wearer to greater shock forces.

[0013] Another type of composite construction prior art

concerns air bladders which employ three dimensional fabric as tensile members such as those disclosed in U.S. Patent Nos. 4,906,502 and 5,083,361 to Rudy. The bladders described in the Rudy patents have enjoyed considerable commercial success in NIKE, Inc. brand footwear under the name Tensile-Air® and Zoom™. Bladders using fabric tensile members virtually eliminate deep peaks and valleys, and the methods described in the Rudy patents have proven to provide an excellent bond between the tensile fibers and barrier layers. In addition, the individual tensile fibers are small and deflect easily under load so that the fabric does not interfere with the cushioning properties of air.

[0014] One Shortcoming of these bladders is that currently there is no known manufacturing method for making complex-curved, contoured shaped bladders using these fabric fiber tensile members. The bladders may be of different heights, but the top and bottom surfaces remain flat with no contours and curves.

[0015] Another disadvantage of fabric tensile members is the possibility of bottoming out. Although the fabric fibers easily deflect under load and are individually quite small, the sheer number of them necessary to maintain the shape of the bladder means that under high loads, a significant amount of the total deflection capability of the air bladder is reduced by the volume of fibers inside the bladder and the bladder can bottom out.

[0016] One of the primary problems experienced with the fabric fibers is that these bladders are initially stiffer during initial loading than conventional gas filled bladders. This results in a firmer feel at low impact loads and a stiffer "point of purchase" feel that belies their actual cushioning ability. This is because the fabric fibers have relatively low elongation to properly hold the shape of the bladder in tension, so that the cumulative effect of thousands of these relatively inelastic fibers is a stiff one. The tension of the outer surface caused by the low elongation or inelastic properties of the tensile member results in initial greater stiffness in the air bladder until the tension in the fibers is broken and the solitary effect of the gas in the bladder can come into play which can affect the point of purchase feel of footwear incorporating a fabric core bladder.

[0017] Another category of prior art concerns air bladders which are injection molded, blow-molded or vacuum-molded such as those disclosed in U.S. Patent No. 4,670,995 to Huang and U.S. Patent No. 4,845,861 to Moundjian. These manufacturing techniques can produce bladders of any desired contour and shape while reducing deep peaks and valleys.

[0018] In Huang '995 it is taught to form strong vertical columns so that they form a substantially rectilinear cavity in cross section. This is intended to give substantial vertical support to the cushion so that the cushion can substantially support the weight of the wearer with no inflation. Huang '995 also teaches the formation of circular columns using blow-molding. In this prior art method, two symmetrical rod-like protrusions of the same width,

shape and length extend from the two opposite mold halves, meet in the middle, and thus form a thin web in the center of a circular column. These columns are formed of a wall thickness and dimension sufficient to substantially support the weight of a wearer in the uninflated condition. Further, no means are provided to cause the columns to flex in a predetermined fashion which would reduce fatigue failures. Huang's columns are also prone to fatigue failure due to compression loads which force the columns to buckle and fold unpredictably. Under cyclic compression loads, the buckling can lead to fatigue failure of the columns.

[0019] Yet another prior art category concerns bladders using a corrugated middle film as an internal member as disclosed in U.S. Patent No. 2,677,906 to Reed which describes an insole of top and bottom sheets connected by lateral connections lines to a corrugated third sheet placed between them. The top and bottom sheets are heat sealed around the perimeter and the middle third sheet is connected to the top and bottom sheets by lateral connection lines which extend across the width of the insole. An insole with a sloping shape is thus produced, however, because only a single middle sheet is used, the contours obtained must be uniform across the width of the insole. By use of the attachment lines, only the height of the insole from front to back may be controlled and no complex-curved, contoured shapes are possible. Another disadvantage of Reed is that because the third, middle sheet is attached with connection lines that extend across the entire width of the insole, all the chambers formed are independent of one another and must be inflated individually which is impractical for mass production.

[0020] The alternative embodiment disclosed in the Reed patent uses just two sheets with the top sheet folded upon itself and attached to the bottom sheet at selected locations to provide rib portions and parallel pockets. The main disadvantage of this construction is that the ribs, which are vertically oriented and similar to the columns described in the patents to Huang and Moumdjian, would resist compression and interfere with and decrease the cushioning benefits of air. As with the first embodiment of Reed, each parallel pocket thus formed must be separately inflated.

[0021] A prior bladder and method of construction using flat films is disclosed in U.S. Patent. No. 5,755,001 to Potter et al. The interior film layers are bonded to the envelope film layers of the bladder which defines a single pressure chamber. The interior film layers act as tensile members which are biased to compress upon loading. The biased construction reduces fatigue failures and resistance to compression. The bladder comprises a single chamber inflated to a single pressure with the tensile member interposed to give the bladder a complex-contoured profile. There is, however, no provision for multiple layers of fluid in the bladder which could be inflated to different pressures providing improved cushioning characteristics and point of purchase feel.

[0022] Another well known type of bladder is formed using blow molding techniques such as those discussed in U.S. Patent No. 5,353,459 to Potter et al. These bladders are formed by placing a liquefied elastomeric material in a mold having the desired overall shape and configuration of the bladder. The mold has an opening at one location through which pressurized gas is introduced. The pressurized gas forces the liquefied elastomeric material against the inner surfaces of the mold and causes the material to harden in the mold to form a bladder having the preferred shape and configuration. The produced bladders typically include a formed seam that is a result of the elastomeric material being forced between the mold halves when the halves are secured together. The seam appears in the center of the sidewalls and is directed outwardly away from the center of the bladder. The seam includes jagged edges and is visible when the bladder is exposed along the midsole of an article of footwear.

[0023] Many articles of footwear include at least one opening along their midsole for exposing the sidewalls of a contained bladder. When the exposed sidewalls are transparent, the interior of the bladder is visible. These openings along the midsole are commonly referred to as "windows" and are usually located in the heel and/or forefoot. Examples of such footwear include the NIKE AIR-MAX shown in the 1995 and 1997 NIKE Footwear catalogs.

[0024] Because the exposed transparent material is vulnerable to being punctured, it must be of a strength and thickness that will resist penetration from external elements. As a result, the requirements of the material used for the exposed sidewalls control the construction, aesthetic and functional characteristics of the entire two film or blow molded bladder. Individual bladder components cannot be customized. Instead, the bladder is formed entirely of the transparent material having the thickness needed to prevent rupturing of the exposed sidewall. This results in the top and bottom of the bladder being formed of the same thick, transparent sidewall material, even if the transparent, puncture resistant material is not needed in these parts of the bladder. Unnecessarily thick top and bottom layers can detract from the overall flexibility of the bladder. Conversely, if certain portions of the bladder, such as the top and bottom surfaces, needed to be made of a thicker material relative to the transparent sidewalls, the transparency and/or flexibility of the sidewalls may be compromised. Using one material for each half of the bladder also prevents the bladder from being customized so different portions of the bladder offer different performance and aesthetic advantages.

[0025] Preparing a bladder for being exposed along the length of a sole window can also include expensive and time consuming manufacturing steps. As discussed, a construction seam can result along the sidewalls of a bladder during manufacturing. The seam appears in the center of the sidewall after the bladder has been inflated. The seam includes a thick, rough edge that during the manufacturing of the bladder must be reduced to prevent

injury and give the sidewalls a smooth, uninterrupted look. The manufacturing steps taken to reduce the seam line increase the manufacturing time and cost of producing a bladder.

[0026] Cushioning system design must meet criteria for both comfort at low loads such as standing, walking, point of purchase feel, and performance at high loads such as running, planting, jumping, pivoting. In analyzing the cushioning characteristics of various devices, it is instructive to view such devices in cross-section. That is, take a visual slice vertically down into the midsole to reveal the cushioning profile of the structure that is to provide the necessary shock absorption and response functions. In prior art cushioning devices, typically any single cross section of the cushioning profile is generally a simple foam core, or a single layer of fluid sometimes surrounded by or encased in foam. This simple profile seeks to balance the low-load - high-load criteria by a compromise to both since a simple cushioning profile provides generally uniform shock absorption and response characteristics along the entire device, but does not provide a complex cushioning profile which can be customized or regionalized to the loads realized at certain points along a bladder.

[0027] A problem with manufacturing complex, highly regionalized bladders of two films has been inordinate twisting of the fluid filled part. A non-planar geometry is difficult to integrate into subsequent shoe making processes.

[0028] There exists a need for a bladder member which solves all of the problems listed above: complex-curved, contoured shapes; no interference with the cushioning benefits of gas alone; provision of regionalized cushioning that can be coupled to the anatomical features of a foot; and simplified manufacture through the use of flat barrier films and integration into existing midsole construction methods. As discussed above, while the prior art has addressed some of these problems, they each have their disadvantages and fall short of a complete solution.

[0029] One object of this invention is to provide a cushioning bladder for footwear with multiple stage cushioning regionalized characteristics constructed of film layers.

[0030] Another object of this invention is to provide a bladder for cushioning an article of footwear that can have different materials for its top outer barrier sheet, bottom outer barrier sheet and sidewalls.

[0031] A further object of this invention is to provide a method of forming a bladder with inverted seam lines that do not require special treatment during manufacturing.

[0032] The basis of the invention which solves the aforesaid problems corresponds to the principal structure of having three separate fluid layers as specified in the beginning of the description and as known already in the specific way of realization from US 5,996,254. The solution according to the invention amends this principal structure as defined in claim 1 by

- at least one of said fluid layers being subdivided into at least two chambers isolated from fluid communication with each other,
- 5 - said chambers containing fluids with differing pressures,
- and a plurality of connection sites that join the first outer layer to the first inner layer, the first inner layer to the second inner layer, and the second inner layer to the second outer layer.

[0033] Accordingly, the bladder of the invention has four barrier layers that form three fluid layers. Furthermore, at least two of the fluid layers contain fluids with differing pressures, and at least one of the fluid layers is subdivided into at least two chambers, and the chambers contain fluids with differing pressures. Accordingly, at least two of the layers have different pressures and at least one of the layers has at least two chambers with different pressures.

[0034] This results in a cushioning system design which meets criteria for both comfort at low loads such as standing, walking, point of purchase feel, and performance at high loads such as running, planting, jumping, pivoting. The above features allow one to form a cushioning profile of a structure that is to provide the necessary shock absorption and response functions. Prior art cushioning profiles being restricted to simple or complex foam or fabric cores, or to a single or double layer of fluid often surrounded by or encased in foam, offer only very limited possibilities along the sole and also vertically. A simple profile of this nature seeks to balance the low-load-high-load criteria by a compromise to both since a simple cushioning profile provides generally uniform shock absorption and response characteristics along the entire device, but does not provide a complex cushioning profile which can be customized or regionalized to the loads realized at certain points along a bladder.

[0035] This problem is solved by the basic complex structure of the bladder according to claim 1 by having three separate fluid layers in one envelope at different pressures and being subdivided into chambers, the number, the form, the place and the pressure of each chamber being determined by the specific demand of the cushioning profile. Providing regionalized cushioning profiles which are coupled to the anatomy of the foot and expected loads at known points is one of the outstanding advantages of the invention. A desired cushioning profile is one that is soft-hard-soft which provides conformable fluid layers near the foot and near the outer surface, and also a layer or chambers of fluid under high pressure designed for high loads to resist bottoming out in one fluid layer.

[0036] The present invention pertains to a cushioning bladder and to a method of making the same. The bladder of the present invention may be incorporated into a sole assembly of a shoe to provide cushioning when filled with

fluid. The bladder and method of the present invention allows for complex-curved, contoured shapes without interfering with the cushioning properties of gas, and provides regionalized cushioning profiles. A complex-contoured shape refers to varying the surface contour of the bladder in more than one direction. The present invention overcomes the enumerated problems with the prior art while avoiding the design trade-offs associated with the prior art attempts.

[0037] In accordance with one aspect of the present invention, a bladder is formed of four layers of barrier film to provide three pressurized layers of cushioning fluid or gas when the bladder is filled to provide layers of distinct cushioning properties. In a preferred embodiment, the distinct properties are caused by multiple pressurized layers of gas, wherein a multiple gas layer bladder enhances cushioning response by relying more on the response characteristics of the gas and reducing the amount of foam and the dependence on foam as a cushioning material.

[0038] The most basic construction according to the invention is a bladder formed of four barrier layers which forms three pressurized layers of gas. A four layer bladder comprises two outer layers sealed around a perimeter to form the envelope of the bladder and two middle layers which are attached to the outer layers and serve as tensile elements. The location of the connection sites of the middle layers to the outer layers determines the topography of the outer surface of the bladder. A middle layer also divides the interior of the bladder into at least two layers of fluid or gas. Additional layers of film between the outer envelope layers provide more layers of fluid or pressurized gas with the interior layers of film being attached to one another in ways to allow for further customization of the cushioning profile.

[0039] Employing film layers as tensile members in contrast to three dimensional fabrics or molded columns provides tensile members which exhibit greater shear strength during oblique loading of the bladder. The internal film layers provide a truss-like geometry in cross section in contrast to the vertical geometry of fibers or columns. The truss-like geometry provides shear resistant cushioning to oblique loads, and is also less prone to fatigue stresses during repeated vertical loading.

[0040] Another aspect of the present invention is the use of flat films to construct complex geometry bladders by varying the locations and shape of connection sites between the film layers to reduce the chances of fatigue failure and to economize manufacturing. Bladders made with flat films are substantially flat until filled with fluid. The bladder that is preferably biased to be flat, i.e. its normal, unfilled condition being generally flat, will experience fewer problems connected with fatigue failure. In addition, flat films simplify manufacture and results in recyclable scrap.

[0041] Still another aspect of the present invention is the construction of bladders from flat films which do not twist or go out of plane upon being filled with fluid and

pressurized. The use of multiple layers of film and the particular connection placements allows for the construction of highly regionalized, multiple pressure bladders which balances the static loads when filled with fluid and virtually eliminates twisting.

[0042] The method of forming a fluid filled bladder for a shoe sole of the present invention comprises the steps of:

- 10 - providing a first outer barrier film and a second outer barrier film;
- interposing a pair of inner barrier films between the first and second outer films;
- 15 - applying a pattern of adhesion inhibitor material to either the opposing sides of the inner films or the inner sides of the outer films;
- 20 - adhering the first and second outer films and the inner turns together along their peripheries to form an envelope with the interposed inner films;
- adhering the outer films to the inner films in areas
- 25 which are not adhesion inhibited; and
- supplying fluid to the envelope so the outer films will pull away from one another and the inner films will act as a tensile member attached to the outer films
- 30 to provide three fluid filled layers.

[0043] These and other features and advantages of the invention may be more completely understood from the following detailed description of preferred embodiments of the invention with reference to the accompanying drawings. Bladders having three film layers and two fluid filled layers as shown in Fig. 1-10 do't form a part of the invention, but their presentation and description contribute to the understanding of the remains embodiments.

FIG. 1 is a perspective view of a bladder constructed of three film layers in accordance with an embodiment.

FIG. 2 is a top plan view of the bladder of FIG. 1.

FIG. 3 is a cross sectional view of the bladder taken along line 3-3 of FIG 2.

FIG. 4 is a perspective view of another bladder constructed of three film layers to illustrate contouring of the outer surfaces by placement of the connection sites.

FIG. 5 is a top plan view of the bladder of FIG. 4.

FIG. 6 is a cross sectional view of the bladder taken along line 6-6 of FIG 5.

FIG. 7 is a perspective view of a full-foot bladder constructed of three film layers in accordance with another embodiment.

FIG. 8 is a top plan view of the bladder of FIG. 7.

FIG. 9 is a cross sectional view of the bladder taken along line 9-9 of FIG. 8.

FIG. 10 is a cross sectional view of the bladder taken along line 10-10 of FIG. 8.

FIG. 11 is a perspective view of a heel bladder constructed of four film layers in accordance with an embodiment of the present invention.

FIG.12 is a top plan view of the bladder of FIG. 11.

FIG.13 is a cross sectional view of the bladder taken along line 13-13 of FIG 12.

FIG.14 is an exploded view of the alignment of an inner bladder to outer film layers of a bladder in accordance with yet another embodiment of the present invention.

FIG. 15 is a top plan view of the bladder of FIG. 14, shown sealed and inflated.

FIG.16 is a cross section of the bladder taken along line 16-16 of FIG 15.

FIG.17 is a cross section of the bladder taken along line 17-17 of FIG 15.

FIG.18 is an exploded view of the alignment of an inner bladder to outer film layers of a bladder in accordance with still another embodiment of the present invention.

FIG.19 is a top plan view of the bladder of FIG. 18, shown sealed and inflated.

FIG.20 is a cross sectional view of the bladder taken along line 20-20 of FIG 19.

FIG. 21 is a cross sectional view of the bladder taken along line 21-21 of FIG 19.

FIG. 22 is a schematic illustration of a section of a heel bladder in its static condition.

FIG. 23 is a schematic illustration of the section of FIG. 22 shown during loading.

FIG. 24 is an exploded perspective view of a shoe incorporating the bladder of FIG. 7 in a sole assembly.

FIGS. 25A and 25B are schematic representations of a five layer bladder in accordance with the present invention.

FIGS. 26A and 26B are schematic representations of a six layer bladder in accordance with the present invention.

FIG. 27 is a top plan view of a complex-contoured three layer tensile bladder adaptable for use within a larger bladder in accordance with the present invention.

FIG. 28 is a side elevational view of the bladder of FIG. 27.

FIG. 29 is a perspective view of the bladder of FIG. 27.

FIG. 30 is a top plan view of a seven layer tensile bladder in accordance with the present invention.

FIG. 31 is a cross-sectional view of the bladder of FIG. 30 taken along line 31-31.

FIG. 32 is a side elevational view of a multiple film layer bladder having an inverted, sidewall seam formed from internal film layers in accordance with

another embodiment of the present invention.

FIG. 33 is a perspective view of the bladder of FIG. 32.

FIG. 34 is a cross-sectional view of the bladder of FIG. 32, taken along the line 34-34 of FIG. 32.

FIG. 35 is a partial cross section of the bladder of FIG 32, before welding and inflation with schematic representations of weld sites.

FIG. 36 is a perspective view of a multiple film layer bladder having a centered inverted, sidewall seam formed from separate sidewall elements in accordance with yet another embodiment of the present invention.

FIG. 37 is a top plan view of the bladder of FIG. 36. FIG. 38 is a side elevational view of one side of the bladder of FIG. 36.

FIG. 39 is a side elevational view of a side of the bladder of FIG. 36 that extends essentially perpendicular to the side shown in FIG. 38.

FIG. 40 is a partial cross section of the bladder of FIG. 36 before welding and inflation with schematic representations of weld sites.

FIG. 41 is a partial cross section of the bladder of FIG. 36 taken along the line 41-41 in FIG. 37.

FIG. 42 is a perspective view of a multiple film layer bladder having a centered inverted, sidewall seam formed from separate sidewall elements in accordance with another embodiment of the present invention.

FIG. 43 is a top plan view of the bladder of FIG. 42. FIG. 44 is a side elevational view of one side of the bladder of FIG. 42.

FIG. 45 is a side elevational view of a side of the bladder of FIG. 42 that extends essentially perpendicular to the side shown in FIG. 44.

FIG. 46 is a partial cross section of the bladder of FIG. 42 taken along the line 46-46 in FIG. 43.

FIG. 47 is a partial cross section of the bladder of FIG. 42 before welding and inflation with schematic representations of weld sites.

FIG. 48 is a side elevational view of a multiple film layer bladder having a displaced inverted, sidewall seam formed from separate sidewall elements in accordance with another embodiment of the present invention.

FIG. 49 is a perspective view of the bladder of FIG. 48.

FIG. 50 is a cross-sectional view of the bladder of FIG. 48 taken along the line 50-50 in FIG. 48.

FIG. 51 is a partial cross section of the bladder of FIG. 48 before welding and inflation with schematic representations of weld sites.

FIG. 52 is a perspective view of a multiple film layer bladder having an inverted seam in the arch region in accordance with another embodiment of the present invention.

FIG. 53 is a side elevational view of the arch side of the bladder of FIG. 52.

FIG. 54 is a top plan view of the bladder of FIG. 52. FIG. 55 is a partial cross section taken along line 55-55 in FIG. 54.

FIG. 56 is a cross section taken along line 56-56 of FIG. 54.

FIGS. 57A to 57F are diagrammatic illustrations of a bladder inflation technique.

[0044] Reference is made to the figures which illustrate some permutations of preferred embodiments of multiple film layer bladders. Due to the complex geometries of multiple film layer bladders, for the sake of clarity, in some instances the perspective views of the bladders are illustrated as if the outer film layers are opaque with the inner construction shown in cross section. It is understood that the film layers may be transparent, tinted or opaque, or some combination of films of different appearance. The term "connection site" is used throughout the application to refer broadly to attachment locations between any of the film layers. A convention employed in the drawings is to show connection sites by outline only or as an outline surrounded by arcs. The sites with arcs depict a connection between an inner film layer and the outer film layer closest to the viewer. The sites showing only the connection outline depict a connection between two inner film layers, or between an inner film layer and the outer film layer furthest from the viewer. The connection sites may be in the form of circular dots, bars, extended lines or any other geometric shape employed to attach any of the film layers to one another. As will be seen in the various preferred embodiments, the outer layers forming the envelope are attached to one another at least along the periphery, and any number of inner layers are attached to one another or to an outer layer.

[0045] All of the figures depict configurations of bladders or parts of bladders which are sealed and filled with fluid. That is, the illustrations are of fluid filled shapes that take form due to the pattern of attachments of the flat film layers.

[0046] For ease of explanation, reference is made to various features of a wearer's foot to clarify directions or locations along the bladders described. The toe, forefoot, metatarsal, arch and heel are used for their customary meanings. "Medial" refers to the sides of a wearer's feet which would face one another, and "lateral" refers to the outside of a wearer's foot.

[0047] An embodiment of a multiple film layer bladder 10 is shown in FIGS. 1-3 which comprises two outer film layers 12 and 14 forming the outer envelope of the bladder, and an inner film layer 16 placed between the outer film layers. Inner film layer 16 forms an inner boundary between two fluid filled layers 17 and 19. Inner film layer 16 is connected to film layers 12 and 14 at connection sites 18 and 20 respectively and along the perimeter to isolate fluid layers 17 and 19 out of fluid communication from one another. In this embodiment the connection sites are formed as circular dot welds. As can be seen in the cross-section views of FIG. 3, connection sites 18

and 20 enable middle film layer 16 to act as a tensile member, extending between outer film layers 12 and 14 and interconnecting them together. Middle film layer 16 also provides a generally evenly contoured outer surface to bladder 10 by virtue of the placement of the connection sites with the outer film layers. Bladder 10 has a filling stem (not shown) which is welded closed after the bladder is filled with fluid. In a finished bladder, the filling stems may be removed leaving a weld location 22 intact to prevent loss of pressure. The shape of bladder 10 makes it suitable for use in a forefoot area to provide cushioning under the metatarsal area of a wearer's foot

[0048] Another three film layer bladder 24 is depicted in FIGS. 4-6 which illustrates the variances in surface contour and thickness of the bladder achieved by varying the placement of weld locations of the inner film layer to each of the outer film layers. Bladder 24 is comprised of outer film layers 26 and 28, and one inner film layer 30 interposed between the outer film layers and interconnecting them. Connection sites 32 and 34 respectively connect inner film layer 30 to outer film layers 26 and 28. In the cross-sectional view, inner film layer 30 can be seen extending between the outer layers. As is apparent from the drawings, to form a thinner portion of bladder 24 the connection sites are spaced closer together, and to form a thicker portion, the connection sites are spaced further apart. The contrast between the two is shown in FIG. 6. Bladder 24 is intended to illustrate the principle of connection site placement and the resultant effect on the thickness and outer surface contour of the bladder.

[0049] A full-foot three film layer bladder is shown in FIGS. 7-10 and the same reference numbers as those used to describe the bladder of FIGS. 1-3 are used with a prime symbol. Bladder 10' is comprised of outer film layers 12' and 14' with an inner film layer 16' interposed between. Inner film layer 16' is attached to the outer film layers along the perimeter and at various connection sites 18' and 20'. The film layers define two fluid filled layers 17' and 19' which may be pressurized to the same or different pressures. As can be seen in FIGS. 7 and 10 in particular, the topography or outer contour of the bladder is varied to make the edges in the heel area form a slight cup or cradle in the center to improve stability. This is seen in FIG. 10 in that the film layers are attached to one another to provide a thinner profile in the center. The connection sites near the edge of the bladder are further apart to provide a thicker profile.

[0050] Three film:bladders provide two layers of fluid which impart cushioning and response characteristics to the bladder and reduce the dependence on any foam used in the shoe sole. The two fluid layers may be of equal pressure or differing pressures depending on the particular cushioning profile desired. For example, if a lower pressure fluid layer is placed closest to a wearer's foot, the shoe sole would impart a softer or springier feel to the wearer. Depending upon the activity for which the shoe is designed, the pressure of the fluid layers may be adjusted and fine tuned to obtain the most desired re-

sponse and feel. Inflation of the bladder is achieved through a valve stem that is open to all fluid layers. As the fluid layers reach their desired pressure, the film layers defining that fluid layer can be sealed at the valve stem to cease inflation of that fluid layer while other layers continue to be pressurized. Sequential sealing of the appropriate film layers in the valve area will enable customized pressurization of the various fluid filled layers of the bladder. This principle can be applied to any number of film layers.

[0051] An alternate inflation technique is illustrated in FIGS. 57A to 57F. For ease of explanation, the inflation of a bladder formed of only two film layers 612 and 614 is illustrated in these figures. As seen in FIG. 57A, sheets 612, 614 are placed one above the other on plate 613, and a die 615 is aligned above plate 613. Die 615 is formed of spaced die plates 615A and 615B, which are used to form an inflation channel. Die plates 615A and 615B are lowered (FIG. 57B) to apply heat and pressure to film layers 612 and 614. Compressed weld areas 617 are formed immediately beneath die plates 615A and 615B, and a weld bead 619 is formed between die plates 615A and 615B. An inflation opening 621 is formed within weld bead 619, and extends to the chambers of the bladder (not shown) which are to be inflated. As seen in FIGS. 57C and 57D, weld bead 619 is placed against a cutting surface 623 and a cutting punch 625, cuts an inlet port 627 (FIG. 57E) to inflation opening 621. An electrode 629, with a gas supply opening 630 is pressed against weld bead 619 (FIG. 57E) and an inflation gas is passed through supply opening 630 and inlet port 627 to inflation opening 621 and the chambers of the bladder being inflated. Electrode 629 is preferably cylindrical in shape, and applies heat and pressure to weld bead 621 to fuse the inlet port and inlet opening closed with a weld 633 after inflation of the chambers has been completed.

[0052] Referring now to FIGS. 11-13, a relatively simple four film layer embodiment of the present invention is disclosed in which the connection sites are generally arranged in an orthogonal array. Bladder 36 comprises outer film layers 38 and 40 which are attached to inner film layers 42 and 44 at connection sites 39 and 41, respectively. Inner film layers 42 and 44 are attached to one another at connection sites 43 which are incoincident, that is, not in alignment, with their connection sites to the outer film layers. As illustrated in the sectional view of FIG. 13, this results in inner layers 42 and 44 extending between outer layers 38 and 40 and acting as a tensile member for the bladder.

[0053] Four film layers result in a bladder with three vertically stacked fluid layers through any cushioning profile: a first outer fluid layer 46; a middle fluid layer 48 and a second outer fluid layer 50. In the embodiment of FIGS. 11-13, middle fluid layer 48 comprises a series of tubular spaces filled with fluid. In a simple form, these three fluid layers may be pressurized to different pressures to obtain a desired cushioning profile. For instance, if a soft-firm-soft profile were desired as one giving the best cushioning

feel to a wearer while providing high pressure fluid in the middle fluid layer for responding to high impact loads, the outer fluid layers could be pressurized to P_1 with the inner fluid layer being pressurized to P_2 , where $P_1 < P_2$. Alternatively, all three fluid layers could be pressurized to different pressures to further customize the cushioning profile.

[0054] Besides being divided into three vertically stacked fluid layers, bladder 36 could be subdivided further into discrete chambers within each fluid layer to further develop the cushioning profile. Inner film layers 42 and 44 could be attached to one another in a more complex relationship so as to afford multiple middle fluid layer chambers. Similarly, the attachment between an outer film layer 38 or 40 with an adjacent inner film layer could be developed further to afford multiple fluid chambers in the outer fluid layers. A more detailed discussion of the formation of discrete chambers within a fluid layer is found in the discussion of FIGS. 14-17.

[0055] In this particular embodiment, bladder 36 is well suited for use in a heel area of a shoe sole with the curved semicircular end being aligned with the rear portion of a wearer's heel. In this manner, stem 52 would be located near the arch area of a wearer's foot. Stem 52 could be located at any convenient peripheral location, and would likely be removed altogether once bladder 36 is filled with fluid and the stem area sealed.

[0056] Consistent with the discussion above, the locations of the connection sites between the inner film layers with one another, and the connection sites between any inner film layer with an adjacent outer film layer, determines the thickness and profile of the resulting bladder. In addition, the particular configuration of the connection sites can be adjusted to form internal fluid filled chambers.

[0057] The embodiments described heretofore are partial foot bladders of relatively simple construction using circular dot welds as connection sites. The principles of the multiple film layer and multiple fluid layer bladder can be applied to any suitable bladder shape and application as will be seen in the following embodiments.

[0058] A full-foot bladder 54 is shown in FIGS. 14-17 comprising four film layers bonded to one another with increased geometric complexity. This bladder defines two discrete chambers or fluid layers which are isolated from fluid communication from one another. In the exploded perspective view, FIG. 14, two outer film layers are aligned with the inner film layers as they would be attached together. The outer film layers are shown as they would appear in a sealed and inflated bladder. In an uninflated state, all of the film layers are flat.

[0059] Bladder 54 comprises outer film layers 56 and 58, and inner film layers 60 and 62. Outer film layers 56 and 58 are sealed along their peripheries to form an envelope, and inner film layers 60 and 62 are sealed along their peripheries to form an inner envelope. Inner film layers 60 and 62 are attached to one another and to adjacent outer film layers 56 and 58 respectively. The pe-

ripheral seal of the inner film layers is spaced away from the peripheral seal of the outer film layers at certain points along the edges of the bladder to define gaps 59. These gaps 59 help keep the upper fluid layer in fluid communication with the lower fluid layer along the bladder.

[0060] Outer film layer 56 is attached to an adjacent inner film layer 60 at circular connection sites 64 and elongated connection sites 66. Identical reference numerals are used to refer to corresponding connection sites between outer film layer 58 and inner film layer 62. Inner film layers 60 and 62 are attached to one another at circular connection sites 68 and elongated connection sites 70.

[0061] FIGS. 16 and 17 illustrate cushioning profiles of bladder 54 taken through various portions of the bladder. In this particular embodiment, the four film layers are interconnected to one another so as to provide an upper fluid layer and a lower fluid layer. The middle fluid layer is formed between the inner film layers, and is formed with a plurality of sub-chambers. As seen in the cross-sectional views, there are three fluid filled layers, some of which are vertically stacked and others which are vertically offset from one another in a vertical profile.

[0062] For example; in the heel area, FIG. 16, fluid layer 72 is formed between outer film layer 56 and an adjacent inner film layer 60, and a fluid layer 74 is formed between outer film layer 58 and an adjacent inner film layer 62.

[0063] For example, in the forefoot area, FIG. 17, a fluid filled layer 72 formed between an outer film layer 56 and an adjacent inner film layer 60 is vertically aligned with fluid filled layer 74 formed between outer film layer 58 and an adjacent inner film layer 62. A central fluid filled layer 76 is formed between inner film layers 60 and 62, and is vertically offset from fluid filled layers 74 and 72.

[0064] It will be apparent that any differences in the locations of the connection sites will result in vertical stacking of some sub-chambers or portions of sub-chambers in any given layer. In the forefoot area, upper and lower fluid layers 72 and 74 are vertically aligned while middle fluid layer 76 is vertically offset from the two outer layers.

[0065] As seen in detail in FIGS. 16 and 17, bladder 54 is constructed so that the edges of inner film layers 60 and 62 are not connected to the peripheral connection between outer film layers 56 and 58 in some areas. Separating the edges of the inner film layers from the outer film layers provides another degree of freedom in constructing the bladder. In general, wherever the edges of all of the film layers are bonded, the profile at that location will be flatter than the areas where the edges of the inner layers are separate from the edges of the outer film layers.

[0066] By varying the levels of pressurization of the fluid filled layers, any desired cushioning profile can be achieved. For instance, taking the cushioning profile of FIGS. 16 and 17, if the pressurization of the outer fluid filled layers 72 and 74 is lower than the pressurization of

central fluid filled layer 76, the resulting cushioning profile will be soft-hard-soft. This is a desired profile for providing soft point of purchase feel and a desirable response for repeated, relatively light loads such as in walking. The higher pressure inner fluid filled layer responds appropriately to higher impact loads such as during jumping or running.

[0067] As best seen in FIGS. 14 and 15, elongated connection sites 70 divide the middle fluid layer into a plurality of discrete sub-chambers A, B, C, D, E, F, and G. Each of these sub-chambers is inflated through a separate inlet port "a" through "g," respectively, so that each sub-chamber can be inflated to a different pressure. The inlet ports are illustrated in their post-inflation state, sealed by a circular weld. Some of the elongated connection sites define narrow inflation channels 75 which provide communication from an inlet port to one of the sub-chambers. In this manner, the cushioning and support provided by the middle fluid layer can be fine tuned along the plane of the foot. For example, chamber "G" can be inflated to 2,0684 bar (30 psi) to provide medial support. Chamber "C" can be inflated to 0,3447 bar (5 psi) to cushion the first metatarsal head. Chamber "F" can be inflated to 0,3447 bar (5 psi) to function as a heel crash pad at foot strike. Chamber "E" can be inflated to 1,38 bar (20 psi) for heel cushioning. Lateral chamber "D" can be inflated to 0,689 bar (10 psi) for lateral arch support. Forefoot chamber "A" can be inflated to 1,724 bar (25 psi) and lateral forefoot chamber "B" can be inflated to 1,034 bar (15 psi) so that both of these chambers provide forefoot cushioning.

[0068] In accordance with the principles of the invention, the connection sites can be arranged as to vary the height of the cushioning profile anywhere along the bladder. The shape or location of the connection sites can also be varied to obtain multiple chambers along any fluid filled layer or between fluid filled layers.

[0069] Another full foot bladder 78, illustrated in FIGS. 18-21, comprises four film layers bonded to one another with mostly elongated connection sites and includes outer film layers 80 and 82 and inner film layers 84 and 86. As with the previous embodiment, these film layers are illustrated as they would be shaped when the bladder is inflated. In the uninflated state, they would be flat films. Outer film layers 80 and 82 are sealed along their peripheries to form an envelope. Inner film layers 84 and 86 are attached to one another at connection sites 88 to define therebetween a middle fluid filled layer 90. Inner film layer 84 is attached to outer film layer 80 at connection sites 92 to define therebetween a fluid filled layer 94. Similarly, inner film layer 86 is attached to outer film layer 82 at connection sites 96 to define therebetween another fluid filled layer 98. FIG. 19 illustrates a plan view of inner film layer 84 and connection sites 88.

[0070] FIGS. 20-21 illustrate cushioning profiles of bladder 78 taken through various portions of the bladder. The four film layers are interconnected to one another to form a plurality of sub-chambers within each fluid filled

layer when viewed in cross section. There are generally three fluid filled layers 90, 94 and 98, some of which are vertically stacked, and others which are vertically offset from one another in a vertical profile.

[0071] For example, in the heel area, FIG. 21, outer fluid layers 94 and 98 make up much of the cross-sectional area in the central portion, with inner fluid layer 90 being relatively small in cross-section. In the forefoot area, FIG. 20, fluid filled layer 94 formed between an outer film layer 80 and an adjacent inner film layer 84 is vertically aligned with fluid filled layer 98 formed between outer film layer 82 and an adjacent inner film layer 86. Central fluid filled layer 90 is formed between inner film layers 84 and 86, and is vertically offset from fluid filled layers 94 and 98.

[0072] Similar to the embodiment illustrated in FIGS. 14-17, certain connection sites 88 divide middle fluid layer 90 into a plurality of discrete chambers A, B, C, D, E, and F, which are inflated through inlet ports "a" through "f," respectively.

[0073] The detailed cushioning profile of the forefoot and the discrete chambers therein, FIG. 20, can best be understood with reference to the FIG. 18 in which inner medial chamber C is formed between connection site 88a which extends longitudinally and medially to surround chamber C. Surrounding inner medial chamber C are fluid filled layers 94 and 98 which are formed between each of the outer film layers and an adjacent inner film layer. Connection site 88b separates chamber B from chamber A, and with connection site 88a defines a fluid inlet channel 114 from inlet port "a" to chamber A. Generally in the center of the forefoot, outer fluid layers 94 and 98 surround fluid inlet channel 114. Toward the lateral side of the bladder, two inner chambers B and D are formed between inner film layers 84 and 86 with a connection site 88c isolating the chambers from one another. Outer connection site 92 attaches outer film layer 80 to inner film layer 84, with a mirror image connection site 96 that attaches outer film layer 82 to inner film layer 86. By arrangement of the connection sites between the four film layers, a cushioning profile of stacked fluid filled layers as seen in FIG. 20 results. The pressures within the various chambers can be equal or unequal depending upon the response characteristics desired.

[0074] The detailed cushioning profile of the heel area, and the discrete chambers therein, is illustrated in FIG. 21 and is also best understood with reference to FIG. 18. The profile of FIG. 21 is a cross-sectional view so that the relationships of the four film layers can be seen beyond line 21-21 of FIG. 19. Beginning at the medial side of the bladder, inner chamber F is defined between the inner film layers by virtue of a peripheral connection site 88d and connection site 88e. The inner chamber is attached to outer film layers 80 and 82 at connection sites 92 and 96 respectively. Outer film layers 80 and 82 extend transversely to the lateral side of the bladder and are attached to inner film layers 84 and 86 at other connection sites 92 and 96. Inner chamber D is formed be-

tween the inner film layers by virtue of peripheral connection site 88d and connection site 88e. Another inner chamber E is located between medial inner chamber F and lateral inner chamber D. Connection site 92a between outer film layer 80 and inner film layer 84 is shown in FIG. 21 to illustrate the structure of the fluid filled bladder. Connection site 92a is illustrative of the connection sites between the outer film layers and inner film layers. Inner film layers 84 and 86 are in tension in the fluid filled bladder as seen in FIGS. 20 and 21, and it can be seen that the size and location of connection site 92a and an aligned connection site 96a determines the spacing between the outer film layers of a fluid filled bladder.

[0075] Bladder 78 of FIGS. 18-21 is constructed so that all of the edges of inner film layers 84 and 86 are joined to the peripheral edges of outer film layers 80 and 82. This generally results in a flatter cushioning profile near the edges of the bladder. Again, varying the levels of pressurization of the fluid filled layers will provide differing cushioning profiles.

[0076] In accordance with the principles of the invention, the connection sites can be arranged as to vary the height of the cushioning profile anywhere along the bladder. The shape or location of the connection sites can also be varied to obtain multiple chambers along any fluid filled layer or between fluid filled layers.

[0077] An example of a soft-hard-soft cushioning profile in a four film layer bladder is shown schematically in FIGS. 22 and 23 in the unloaded and loaded condition. This cushioning profile is of the metatarsal head region. As will be apparent from the preceding discussion, side chambers 146 and central chambers 148 are formed from the inner film layers and top and bottom chambers 150 are formed between an outer film layer and an adjacent inner film layer. In this example, side chambers 146 are pressurized to 2,41 bar (35 psi) inner chamber 148 are pressurized to 1,724 bar (25 psi) while the top and bottom chambers are pressurized to 1,034 bar (15 psi). In this cushioning profile, the lower pressure chambers 150 will provide a soft point of purchase feel and general cushioning for light loads. When a high impact load L is applied, high pressure central chambers 148 will provide the needed dampening of the load, and higher pressure side chambers 146 will stabilize the wearer's foot by providing a stiffer response at the sides to cradle the curved metatarsal head of a wearer's foot. This profile illustrates an example of bladder construction and pressurization to provide, anatomically coupled, regionalized cushioning for a wearer's foot.

[0078] A bladder 10' is illustrated in FIG. 24 as part of a midsole assembly for a shoe. The shoe comprises an upper U, a insole I, a midsole assembly M and an outsole O. While the full-foot bladder 10' is shown in the drawing, any of the bladders described herein or alternative constructions thereof can be substituted in the midsole assembly 11. Bladder 10' can be incorporated into the midsole assembly M by any conventional technique such as foam encapsulation or placement in a cut-out portion of

a foam midsole. A suitable foam encapsulation technique is disclosed in U.S. Patent No. 4,219,945 to Rudy.

[0079] Five and six film layer bladders have been constructed but are difficult to clearly illustrate in patent drawings due to their complexity. Cross-sectional schematic representations of bladders with five and six film layers are provided in FIGS. 25A, 25B, 26A, and 26B, respectively. FIGS. 25B and 26B are schematic representations of multi-layered bladders shown with the film layers exploded and with dots depicting connection sites between film layers. FIGS. 25A and 26A depict the bladders after the connections are made and the bladders are inflated. The five film layers of the bladder are clearly seen in FIG. 25A, and the contoured cross-section of the bladder is seen in FIG. 25A. At the medial and lateral edges, bladder chambers are stacked to form thicker edges, while a single layer of bladder chambers is centrally located.

[0080] The six layer bladder of FIGS. 26A and 26B illustrates several regions available for filling with fluid at different pressures. The bladder of FIGS. 26A and 26B is shown with shaded chambers to denote a different pressure from the unshaded chambers. If the shaded chambers were of a higher pressure than the unshaded chambers, the portion of the bladder including the higher pressure chambers would be more rigid and provide more support than the remainder of the bladder. Conversely, the lower pressure region would provide more cushioning than the remainder of the bladder. Thus, the right-hand side of the bladder as seen in FIGS. 26A and 26B would be more rigid and provide more support compared to the cushioning of the left-hand side of the bladder. One of ordinary skill in the art would be able to apply these principles to vary the pressurization in the chambers to customize the cushioning profile of the bladder.

[0081] FIGS. 27-31 illustrate another multi-layered bladder comprising three layer bladders placed within an open area of a four layer bladder. Three layer bladder 152 comprises an upper barrier layer 154, and a lower barrier layer 156 and a tensile element 158 disposed therein. Tensile element 158 comprises a single sheet of polyurethane film. To make bladder 152, tensile element 158 which is selectively die cut to the appropriate shape is placed between upper and lower barrier layers 154 and 156. Weld prevention material is selectively placed between the upper and lower barrier layers and the tensile element as desired, and the assembly is welded so that welds 160 are provided as shown. Upper and lower barrier layers 154 and 156 are then welded together around their periphery to seal bladder 152, and an inflation conduit 162 leading to an inflation point 164 is provided. Bladder 152 is then inflated through inflation point 164, after which the inflation point 164 is sealed. Similar to the first preferred embodiment, tensile element 158 is welded to the barrier layers which make up the envelope of bladder 152 when the films are in a flattened state so that the compressed or loaded condition of bladder 152 correspond to the least stressed state of tensile element 158. Thus, tensile element 158 does not hamper the

cushioning properties of the air when the inflated bladder is compressed. By selectively die cutting the interior sheet and selectively placing weld prevention materials alternately adjacent the upper and lower barrier layers, a variety of bladder shapes may be obtained.

[0082] A three layer bladder such as bladder 152 can be placed within another bladder as shown in FIGS. 30-31 to construct a bladder with multiple cushioning regions and layers. Bladder 166 has a generally rectangular outline shape and comprises two outer layers 168 and 170 and two inner layers 172 and 174 attached to one another to form a tensile element 176 and interconnecting the outer layers in the main body of the bladder. Connection sites 178 between an outer layer and an inner layer are depicted as bars in the main body portion of bladder 166. An exemplary connection site between the inner layers is labeled 180 for illustration purposes. At one end of bladder 166, two three layer bladders 152 have been placed to provide a region of five film layers. Where bladder 152 is positioned within bladder 166, outer layers 154 and 156 are attached to outer layers 168 and 170 respectively so that the internal bladder 152 acts as the tensile member in that region of the bladder. Internal bladders 152 are also anchored into position by attachment of inflation conduits 164 at the peripheral seam of bladder 166. Bladder 152 is pressurized to a higher pressure than bladder 166 so that the portion of bladder 166 containing three layer bladders 152 exhibits a stiffer response to cushioning than the main body portion of the bladder which only has tensile member 172 which does not interfere with the cushioning effects of air. By adding non-communicating multiple layer chambers such as internal bladder 152, the cushioning characteristics of the bladder can be varied while still providing a complex-contoured shape without deep peaks and valleys. A complex-contoured tensile bladder into which three layer bladders 152 can be incorporated is disclosed in U.S. Patent No. 5,802,739 to Potter et al.

[0083] When four or more film layers are used in the construction, an alternative conceptual principle is that of a bladder comprising a group of fluid filled inner chambers and two outer film layers overlaying the inner chambers and attached to them at selected connection sites to provide an outer chamber or two. This construction results in a stable, planar bladder in which the outer film layers moderate the inner chambers, especially if the inner chambers are of higher pressure than the outer chamber. The higher pressure chambers formed of flat films may also tend to twist, and the addition of outer films and a lower pressure outer chamber would prevent twisting by balancing the static loads of the bladder when filled with fluid.

[0084] The multiple film layer bladders of the present invention may also be constructed with an inverted seam along the sidewall. As shown in FIGS. 32-35, an inverted seam may be formed of the inner barrier sheets. Bladder 210 includes top, outer barrier layer 212 formed of a sheet of barrier material and a bottom, outer barrier layer 214

formed of a sheet of barrier material. Barrier layers or sheets 212 and 214 are referred to as "top barrier sheet" and "bottom barrier sheet," respectively, for ease of explanation. The use of the reference terms "top," "bottom," etc. are not intended to be limiting on the present invention, but rather are for ease of description and refer to the orientation of the bladders as shown in the figures. Layers 212 and 214 can be secured directly to each other along edge 211, as shown at the right side of FIG. 32 and in the prior embodiments, or operatively secured to each other by sidewall(s) 216, as shown in FIG. 33. Edge 211 is positioned within an article of footwear so that it is surrounded by midsole or outsole materials when the footwear is constructed, see FIG. 24.

[0085] Bladder 210 is constructed so that sidewalls 216 are the same size or larger than the windows exposing them, i.e., openings in the side of the midsole. The number and size of the sidewalls 216 can depend on how many windows are in the midsole of the footwear, how much of bladder 210 is intended to be exposed through each bladder window and the size of each window. A sidewall can be individually formed for each window or one wall can be formed for extending within and between all of the windows. For example, a bladder in the heel may be exposed by one or more windows on each side of the footwear and include the same number of sidewalls as windows. In the alternative, the midsole can be formed with a single window that wraps around the heel.

[0086] As best seen in FIG. 34, each sidewall 216 is formed by attaching the edges of the two inner barrier layers to the top and bottom outer layers adjacent a weld of the two inner barrier layers. Each sidewall 216 has an upper sidewall portion 217 and a lower sidewall portion 218 connected at an inwardly directed or inverted seam 250 formed by securing the two inner layers together by using securing techniques such as radio frequency (RF) welding, discussed below. Sidewall portions 217, 218 in this bladder are the terminal ends of a tensile member 232. A tensile member is an internal element within a bladder that insures a fixed, resting relation between the top and bottom barrier layers when the bladder is fully inflated. Tensile members often act as restraining members for maintaining the general form of the bladder. An example of tensile members includes at least one inner sheet of a barrier material secured at certain locations along the bladder to form an internal framework that maintains the shape of the bladder as described in the '001 patent to Potter et al. In another tensile member embodiment, the bladder chamber could include three dimensional fabric extending between the top and bottom sheets of barrier material such as those disclosed in U. S. Patent Nos. 4,906,502 and 5,083,361 to Rudy.

[0087] Bladder 210 includes tensile member 232 formed of two inner barrier layers 252, 253 formed of sheets of barrier material. Layers 252 and 253 are sealed together and extend between the inner surfaces 262 of top and bottom barrier layers 212 and 214 for maintaining the shape and contour of bladder 210. Inner layers 252,

253 are secured to outer layers 212 and 214 using conventional techniques such as RF welding. The resulting welds 233 formed between any of the layers at the points of attachment are indicated schematically in FIG. 35 by "X" Barrier layers 252 and 253 are secured together to establish an inner bladder chamber 255 providing multi-stage or multi-layer cushioning within bladder 210. Chamber 255 can include a plurality of internal channels.

[0088] Outer barrier layers 212 and 214 are welded together along their peripheral edges 280, 281 to the peripheral edges 282, 283, respectively of inner barrier layers 252 and 253. This peripheral welding, as well as the interior welds 233 between the inner and outer layers results in a plurality of upper bladder chambers 221 above layer 252 and chambers 255, and a plurality of lower bladder chambers 222, below layer 253 and chambers 255. When the peripheral edge 282 of layer 252 is secured to the entire peripheral edge 281 of outer layer 212 and the peripheral edge 283 of layer 253 is secured to the entire peripheral edge 281 of outer layer 214, chambers 221 will be isolated from chambers 222 so that they are not in fluid communication. The three chambers 221, 255, and 222 allow for at least three different fluid pressures to be achieved within bladder 210. The fluid pressure within chambers 255 is preferably greater than that in chambers 220 and 222 so that bladder 210 will not bottom out under an applied load. Specifically, the pressure in chamber 255 is substantially in the range of 1,379 to 3,447 bar (20 to 50 psi).

[0089] FIGS. 36-47 illustrate inverted seam bladders having a centered inverted seam which is formed of separate sidewall elements. A first such embodiment, bladder 310, is shown in FIGS. 36-41; and a second embodiment, bladder 310', is shown in FIGS. 42-47. Bladders 310, 310' are designed for positioning in the forefoot of an article of footwear so their sidewalls 316, 316' are exposed through a forefoot window or pair of forefoot windows along the lateral or medial side of an article of footwear. Bladder 310 includes top, outer barrier layer 312 formed of a sheet of barrier material and bottom, outer barrier layer 314 also formed of a sheet of barrier material. Layers 312 and 314 can be secured directly to each other along their unexposed sides 311, as shown in FIG. 39. The sides 311 of bladder 310 that are not intended to be exposed by a bladder window extend across the width of the footwear and are covered by material forming the midsole or outsole. Layers 312 and 314 are operatively secured to each other along their exposed sides by sidewall(s) 316, as shown in FIGS 38-40. Welds 333 are schematically indicated by "X" representing the points of attachment between the layers of bladder 310 in FIG. 40.

[0090] Bladder 310 is constructed so that sidewalls 316 are the same size or larger than the windows exposing them. The number and size of the sidewalls 316 can depend on how many windows are in the midsole of the footwear, how much of bladder 310 is exposed through each bladder window and the size of each window. Each

sidewall 316 is formed of an upper sidewall piece 317 and a lower sidewall piece 318 connected at an inverted seam 350 using well known securing techniques such as welding. Seam 350 is inwardly directed toward the center of the bladder and is centered along the sidewall. Sidewall pieces 317, 318 in this bladder are formed of individual pieces of barrier materials separate from tensile member 332, and peripheral edges 380 and 381 of layers 312 and 314 are secured to edges 382, 383 of sidewall pieces 317 and 318.

[0091] A tensile member 332 is formed of two inner barrier layers 352, 353. Each layer 352, 353 is formed of a sheet of barrier material. Layers 352, 353 are sealed together and extend between the inner surfaces 362 of top and bottom barrier sheets 312, 314 for maintaining the shape and contour of bladder 310. Sealed layers 352, 353 provide a plurality of chambers 355 for containing a fluid that provides a second level of cushioning within bladder 310. The fluid pressure within region 355 can be greater than that in chambers 321 and 322 so that bladder 310 will not bottom out during use. As shown in FIG. 40 sidewall pieces 317 and 318 are not integral with layers 352 and 353 and a gap exists between the inner edges 390, 391 of sidewalls pieces 317 and 318 and the peripheral edges 392, 393 of inner barrier layers 352 and 353 so that bladder chambers 321 and 322 are not divided into two separate bladder chambers as in FIGS. 32-35. Rather, bladder chambers 321 and 322 are in fluid communication with one another via a peripheral bladder chamber 320.

[0092] Bladder 310', shown in FIGS. 42-47, is similar to bladder 310 in that it includes top and bottom barrier layers 312', 314' formed of sheets of at least one barrier material and connected along edge 311'. It also includes sidewalls 316' formed of sidewall pieces 317', 318' positioned between layers 312' and 314'. As shown in FIGS. 46 and 47, sidewall pieces 317' and 318' are secured to layers 312', 314' and each other so they form an inverted seam 350'. Bladder 310' only differs from bladder 310 in its internal tensile member 332'. Unlike tensile member 332, tensile member 332' does not form an internal region with multiple chambers. Instead, tensile member 332' includes at least one internal layer 352', formed of a sheet of a barrier material, secured to the inner surfaces 362' of top and bottom layers 312', 314' using well known techniques such as welding. The welds 333' are shown by an "X" in FIG. 47 to indicate schematically the locations of the welds. Tensile member 332' forms communicating channels 340' within chamber 320'.

[0093] FIGS. 48-51 illustrate another embodiment of the present invention in a bladder having an inverted seam which is offset or displaced from the center of the sidewall. In FIG. 48 bladder 410 includes outer barrier layers 412, 414 formed of sheets of barrier material. Layers 412 and 414 are secured directly to each other along edge 411 and operatively secured to each other by sidewall(s) 416. Each sidewall 416 is formed of an upper sidewall piece 417 and a lower sidewall piece 418 secured

together at an inwardly directed seam 450 which is offset or displaced from a central position on the sidewall.

[0094] Bladder 410 also includes a tensile member 432 having two inner barrier layers 452, 453 sealed together and extending between the inner surfaces 462 of top and bottom barrier sheets 412, 414 for maintaining the shape and contour of bladder 410. Layers 452 and 453 can be secured to inner surfaces 462 at a plurality of weld sites by RF welding. Layers 452, 453 are sealed about their perimeter and at a plurality of weld sites by welds 433, marked by an "X" in FIG. 51 and schematically representing weld sites to form an internal cushioning chamber 456 for containing a fluid that provides another level of cushioning within bladder 410.

[0095] The outer walls of bladder 410 are formed by securing the peripheral edges 480 and 481 of upper and lower layers 412 and 414, respectively, to the edges 482 and 483 of sidewalls 417, 418, respectively and securing sidewalls 417 and 418 to each other along their other edge at inverted displaced seam 450. Chamber 420 is formed between the outer walls defined by layers 412, 414, and sidewalls 417, 418, and an interior chamber 455 formed by layers 452, 453. Chamber 420 contains a fluid for initially cushioning the shock generated during a foot strike. As shown in FIGS. 50-51, sidewall pieces 417 and 418 are not integral with layers 452 and 453 so bladder chamber 420 is not divided into two parts like chamber 20 in FIGS. 32-35. Chamber 455 includes a fluid to provide additional cushioning to dampen the shock generated during a foot strike. The fluid pressure within chamber 455 is greater than that in chamber 420 as discussed above with respect to bladder 210.

[0096] Inverted seam 450 of bladder 410 is displaced from the center of sidewall 416. The location of seam 450 is determined by the relative size of sidewall pieces 417 and 418. As shown in FIGS. 50-51, sidewall piece 418 is larger than piece 417. More specifically, piece 418 is approximately twice the width of piece 417. The size difference in combination with the location of the welds indicated with an "X," shown in FIG. 51, causes seam 450 to be displaced from the center of the sidewall when the bladder is inflated. The seam is located along sidewall 416 a distance equal to the span of piece 418 between its points of attachment to layer 414 and piece 417. Displaced seam 450 produces a sidewall 416 having its seam positioned at or above the upper limit of a bladder window through which it is exposed. Conversely, piece 417 can be larger than piece 418 so that seam 450 occurs at the bottom of the window instead of the top. The inverted orientation of seam 450 and its displacement to an edge hide it completely from a bladder window to give a clean, seamless appearance. This attachment method eliminates costly manufacturing steps taken to improve the appearance of the exposed bladder window and eliminate the thick rough edge.

[0097] This is especially true if seam 450 is offset from the center of the bladder a distance greater than half the height of the bladder window so the seam is completely

offset from the window and only sidewall piece 418 is exposed. Such an offset allows larger sidewall part 418 to be formed of the transparent material while sidewall part 417 is formed of an opaque material. Moreover, moving the seam 450 in this manner can also increase the life of the bladder by moving the seam away from the areas of predicted high stresses. Although the displaced seam 450 is only discussed with respect to bladder 410, it could also be used with the other bladders according to the present invention.

[0098] FIGS. 52-56 illustrate a full length bladder 500 having a raised arch region 510 for providing support to the arch of a user in place of pads positioned below the insole of an article of footwear. Top and bottom barrier layers 512, 514 of bladder 500 can be secured directly together as at seam 511. Alternatively, they can be secured using an inverted seam. In this embodiment, the inverted seam is placed in the arch region 510, top layer 512 is secured to one end of first sidewall piece 516 of barrier material. A first end of second sidewall piece 517 is secured to bottom layer 514. The other end of sidewall piece 517 is secured to a first end of an intermediate piece 515 so an inverted seam 550 is formed between the two sidewall pieces 515, 517. The other end of intermediate piece 515 is secured to first sidewall piece 516 so that top and bottom layers 512, 514 are operatively connected.

[0099] Inverted seam 550 minimizes the distance the sidewall pieces 516, 517 extend away from the peripheral edge of bottom layer 514. The less the sidewalls extend away from the center of the bladder 500, the more the arch region can be built up and away from the center of the bladder without extending beyond the limits of the footwear into which it is incorporated.

[0100] Regarding the materials for the bladders disclosed herein, the top and bottom barrier sheets, sidewalls elements and inner barrier layers can be formed from the same or different barrier materials, such as thermoplastic elastomer films, using known methods. Thermoplastic elastomer films that can be used with the present invention include polyester polyurethane, polyether polyurethane, such as a cast or extruded ester based polyurethane film having a shore "A" hardness of 80-95, e.g., Tetra Plastics TPW-250. Other suitable materials can be used such as those disclosed in U.S. Patent No. 4,183,156 to Rudy. Among the numerous thermoplastic urethanes which are particularly useful in forming the film layers are urethanes such as Pellethane™, (a trademarked product of the Dow Chemical Company of Midland, Michigan), Elastollan® (a registered trademark of the BASF Corporation) and ESTANE® (a registered trademark of the B.F. Goodrich Co.), all of which are either ester or ether based and have proven to be particularly useful. Thermoplastic urethanes based on polyesters, polyethers, polycaprolactone and polycarbonate macrogels can also be employed. Further suitable materials could include thermoplastic films containing crystalline material, such as disclosed in U.S. Patent Nos.

4,936,029 and 5,042,176 to Rudy; polyurethane including a polyester polypol, such as disclosed in U.S. Patent No. 6,013,340 to Bonk et al.; or multi-layer film formed of at least one elastomeric thermoplastic material layer and a barrier material layer formed of a copolymer of ethylene and vinyl alcohol, such as disclosed in U.S. Patent No. 5,952,065 to Mitchell et al..

[0101] In accordance With the present invention, the multiple film layer bladder can be formed with barrier materials that meet the specific needs or specifications of each of its parts. The present invention allows for top layer to be formed of a first barrier material, bottom layer to be formed of a second barrier material and each part of the sidewall(s) to be formed of a third barrier material. Also, the sidewall parts can each be formed of different barrier materials. As discussed above, the inner barrier sheets and the sidewall parts are formed of the same barrier material when the inverted seam is formed by attaching the terminal ends of inner barrier sheets to the outer barrier sheets adjacent a weld of the inner sheets. As a result, when the inner barrier sheets are formed of a different material than outer barrier sheets, the sidewalls are formed of the same material as the inner barrier sheet material. Also, when the inner barrier sheets are formed of different materials, sidewall parts must be are formed of different materials as well for compatibility.

[0102] If the inner layers are to be visible through a bladder window, the sidewall will most likely be formed of a transparent material for maximum visibility. In the inverted seam embodiments shown in the figures, the top and bottom layers do not need to be formed of a transparent material. Instead, they can each be formed of an opaque barrier material having the same or different thicknesses. Similarly, the sidewall pieces can be formed of a thicker or thinner transparent material so the interior is visible. The thickness of sidewall 16 depends on at least the material used, the environment surrounding the bladder and the structural requirements of the sidewalls. Film thicknesses for the top and bottom layers are generally in the range of 0,127 mm to 2,54 mm (five (5) to one hundred (100) thousandths of an inch (0.005 to 0.100 inches)). If a thicker sidewall is desired, its thickness is generally in the range of 0,635 mm to 5,08 mm (twenty-five (25) to two hundred (200) thousandths of an inch (0.025 to 0.200 inches)).

[0103] According to the present invention, the barrier materials used for each portion of the bladder can be customized to meet only the specific needs of that portion. For example, if the top and bottom layers use an opaque, relatively thin, flexible barrier material, the exposed sidewalls can be made of a thicker, stiffer, transparent barrier material. Contrary to industry practice, only the portion of the bladder being shown in a bladder window would then be made from the stiffer transparent material. Also, the sidewalls can be made with a pre-shaped form or with greater rigidity to vertical compression in order to compliment the pressure in the bladder or individual pressure regions within the bladder. The materials

chosen for sidewalls could also be used to stiffen portions of the footwear that experience compressive and sheer loading, such as the medial side of the heel. An economic benefit is also realized. By not forming the top and bottom layers with the same material as the sidewalls, the cost of producing a bladder can be reduced. According to the present invention, the most expensive materials are only used where needed, not over the entire bladder.

[0104] The bladder is inflated preferably with a gaseous fluid, for example, hexafluoroethane, sulfur hexafluoride, nitrogen, air, or other gases such as those disclosed in the aforementioned '156, '945, '029, or '176 patents to Rudy, or the '065 patent to Mitchell et al.

[0105] The method of forming a bladder with at least one inverted sidewall seam according to the present invention includes selecting the material for each portion based on at least the forces and stresses it will experience and the performance characteristics it is intended to provide. The aesthetics of each portion of the bladder must also be considered. For example, if the interior of the bladder is intended to be visible, the exposed sidewall(s) need to be formed of a transparent material that allows the desired visibility. However, as discussed above, the transparent material must also be strong enough to prevent rupturing from externally applied forces and to withstand bending stresses applied to bladder sidewalls during the stride of the user. While the sidewalls are transparent and include a thickness of 0,508 mm to 2,54 mm (0.020 to 0.100 inches), the top and bottom layers of the bladder may be formed of an opaque material having a thickness of 0,127 mm to 1,27 mm (0.005 to 0.050 inches) to meet the specific needs of their final location in the shoe, as discussed above. If a bladder configuration is desired that provides visibility from only the bottom surface, the top and bottom films can be different. A clear film with a thickness in the range of 0,50 mm to 2,54 mm (020" - .100") could be used on the bottom surface and a standard opaque film of 0,127 mm to 1,27 mm (005" - .010") could be used for the top and side surfaces.

[0106] After the size and types of materials have been determined, the barrier sheets forming the top layer, bottom layer and sidewalls are shaped using well known cutting or forming techniques. The flat, shaped sheets are then positioned so their peripheral edges form the perimeter of the bladder. The sidewall pieces are positioned between the top and bottom barrier sheets and secured thereto using well known techniques such as RF welding. The barrier sheets used to form the bladders are selectively treated with a weld prevention material which prevents RF welds from being formed. Examples of weld inhibitors are Teflon® coatings and Teflon® coated fabrics or strips, such as Du Pont Teflon® #49 or #57, which can be positioned wherever welds are to be inhibited. Other conventional weld inhibitors or blockers, such as tapes manufactured by 3M, including Scotch "Magic Mending" tape and Highland 3710 Box Sealing tape, or tape manufactured by Faron, including Kapton PSA tape or Teflon® PSA tape, Fluoroglide "FB" spray lubricant by

Norton, or water-based coatings by Graphic Sciences with either Teflon® or parafin, a styrenic acrylic polymer, can be used between the layers and sidewalls to insure that only the intended portions of the bladder are secured together. The inhibitors are either removed after welding or are consumed in the RF welding process.

[0107] To make any of the bladders described herein, the weld pattern for each layer is first determined and marked on the sheets. The weld pattern would correspond to the pattern of connection sites on the specific side of a layer. This pattern is marked on the sheets either in the positive or negative by screen printing, inkjet printing, or a transfer method. The marking can be visible as with an ink, or invisible as with a transfer method which applies weld inhibiting material onto the side of the film layer. It will be understood that the weld prevention materials would generally be the negative image of the desired connection sites. The application of weld inhibiting material onto the layer can be a separate method step from the marking of the connection sites. The variety of connection site shapes and configurations is limited only by the application of weld inhibiting material to the layers.

[0108] Once the connection sites are properly marked and the weld inhibiting material applied to the film layers, RF energy is applied and RF welding takes place only where layers are in direct contact with one another and not separated by weld prevention material. The peripheral seal of the outermost layers to form the envelope of the bladder can be formed in an integral step with the remainder of the welds, or could be formed before or after the welding of the connection sites. After the bladder is formed, it is filled with fluid, and the inlet port is sealed off by a RF weld.

[0109] While RF welding has been the preferred method of making the multi-stage cushioning bladders of the present invention, the particular type of attachment may vary. For instance, an adhesive bond between film layers may be used, as well as other known fusion, thermal, and ultrasonic bonding methods.

[0110] After the bladder has been assembled and the chambers formed, the bladder chambers can be inflated using well known techniques. While the preferred method is to use flat sheets of material, the sidewalls, and outer and inner barrier layers, can also be preformed to have different shapes and effects before they are secured together to form the bladder. For example, shapes can be formed by thermoforming the sheets of the barrier layer materials.

Claims

1. A fluid-filled bladder for a shoe sole comprising:

- an envelope formed of a first outer layer (56) and a second outer layer (58) of barrier film material sealed along their peripheries; and
- a first inner layer (60) and a second inner layer

(62) of barrier film material positioned between said first outer layer (56) and said second outer layer (58),

- said inner layers (60, 62) dividing said envelope into a first fluid layer (72), a second fluid layer (76), and a third fluid layer (74) located between said first outer layer (56) and said second outer layer (58),

- at least two of said fluid layers (72, 74, 76) containing fluids with differing pressures,

characterized by

- at least one of said fluid layers (72, 74, 76) being subdivided into at least two chambers (A-G) isolated from fluid communication with each other,

- said chambers (A-G) containing fluids with differing pressures,

- and a plurality of connection sites (64, 66, 68, 70) that join the first outer layer (56) to the first inner layer (60), the first inner layer (60) to the second inner layer (62), and the second inner layer (62) to the second outer layer (58).

2. The fluid-filled bladder of claim 1, wherein the fluids are gasses.
3. The fluid-filled bladder of claim 1, wherein said first inner layer (60) is located adjacent to said first outer layer (56) and said second inner layer (62) is located adjacent to said second outer layer (58).
4. The fluid-filled bladder of claim 2, wherein said first fluid layer (72) is located between said first outer layer (56) and said first inner layer (60), said second fluid layer (76) is located between said first inner layer (60) and said second inner layer (62), and said third fluid layer (74) is located between said second inner layer (62) and said second outer layer (58).
5. The fluid-filled bladder of claim 4, wherein said chambers are located in said first fluid layer (72), said chambers being formed by attaching said first outer layer (56) to said first inner layer (60).
6. The fluid-filled bladder of claim 4, wherein said first fluid layer (72), said second fluid layer (76), and said third fluid layer (74) are isolated from fluid communication with each other.
7. The fluid-filled bladder of claim 4, wherein portions of said first fluid layer (72) are in fluid communication with portions of said third fluid layer (74).
8. The fluid-filled bladder of claim 7, wherein said portions of said first fluid layer (72) are located on a periphery of said first and second fluid layers (72, 76).

9. The fluid-filled bladder of claim 4, wherein said chambers (A-G) are located in said second fluid layer (76), said chambers (A-G) being formed by attaching said first inner layer (60) to said second inner layer (62).

10. The fluid-filled bladder of claim 9, wherein the pressures in said chambers (A-G) are greater than the pressures in said first fluid layer (72) and said third fluid layer (74).

11. The fluid-filled bladder of claim 9, wherein the pressures in said chambers located in peripheral portions of said second fluid layer (76) are greater than the pressures in said chambers located in interior portions of said second fluid layer (76).

12. A method of making a fluid filled bladder for a shoe sole comprising the steps of:

- providing a first outer barrier film (56) and a second outer barrier film (58);

- interposing a pair of inner barrier films (60, 62) between the first and second outer films (56, 58);

- applying a pattern of adhesion inhibitor material to either the opposing sides of the inner films (60, 62) or the inner sides of the outer films (56, 58);

- adhering the first and second outer films (56, 58) and the inner films (60, 62) together along their peripheries to form an envelope with the interposed inner films (60, 62);

- adhering the outer films (56, 58) to the inner films (60, 62) in areas which are not adhesion inhibited; and

- supplying fluid to the envelope so the outer films (56, 58) will pull away from one another and the inner films (60, 62) will act as a tensile member attached to the outer films (56, 58) to provide three fluid filled layers (72, 74, 76).

13. The method of claim 12, wherein said step of supplying fluid to the envelope comprises supplying different fluids to the two fluid filled layers to vary the cushioning characteristics of the bladder in a vertical direction.

14. The method of claim 12, wherein said step of applying adhesion inhibitor material includes applying a pattern of adhesion inhibitor material to form two discrete sub-chambers in a fluid filled layer.

15. The method of claim 14, wherein said step of supplying fluid comprises supplying a gas to the envelope and pressurizing the sub-chambers to different pressures.

16. The method of claim 12, wherein said step of supplying fluid comprises supplying a gas to pressurize

the fluid filled layers.

Patentansprüche

1. Mit Strömungsmedium gefüllte Blase für eine Schuhsohle, aufweisend:

- eine Hülle, gebildet aus einer ersten äußeren Schicht (56) und einer zweiten äußeren Schicht (58) aus Sperrfolienmaterial, die längs ihres Umfangs abgedichtet sind; und
- eine erste innere Schicht (60) und eine zweite innere Schicht (62) aus Sperrfolienmaterial, angeordnet zwischen der ersten äußeren Schicht (56) und der zweiten äußeren Schicht (58),
- wobei die inneren Schichten (60, 62) die Hülle unterteilen in eine erste Schicht für Strömungsmedium (72), eine zweite Schicht für Strömungsmedium (76) und eine dritte Schicht für Strömungsmedium (74), angeordnet zwischen der ersten äußeren Schicht (56) und der zweiten äußeren Schicht (58),
- mindestens zwei der Schichten für Strömungsmedium (72, 74, 76) Strömungsmedien mit verschiedenen Drücken aufweisen,

gekennzeichnet dadurch, daß

- mindestens eine der Schichten für Strömungsmedium (72, 74, 76) in mindestens zwei Kammern (A-G) unterteilt ist, die bezüglich einer Strömungsverbindung voneinander isoliert sind,
- die Kammern (A-G) Strömungsmedien mit verschiedenen Drücken aufweisen, und
- eine Vielzahl von Verbindungsstellen (64, 66, 68, 70) die erste äußere Schicht (56) mit der ersten inneren Schicht (60), die erste innere Schicht (60) mit der zweiten inneren Schicht (62) und die zweite innere Schicht (62) mit der zweiten äußeren Schicht (58) verbinden.

2. Mit Strömungsmedium gefüllte Blase nach Anspruch 1, wobei die Strömungsmedien Gase sind.
3. Mit Strömungsmedium gefüllte Blase nach Anspruch 1, wobei die erste innere Schicht (60) der ersten äußeren Schicht (56) benachbart angeordnet ist und die zweite innere Schicht (62) der zweiten äußeren Schicht (58) benachbart angeordnet ist.
4. Mit Strömungsmedium gefüllte Blase nach Anspruch 2, wobei die erste Schicht für Strömungsmedium (72) zwischen der ersten äußeren Schicht (56) und der ersten inneren Schicht (60) angeordnet ist, die zweite Schicht für Strömungsmedium (76) zwischen der ersten inneren Schicht (60) und der zweiten in-

neren Schicht (62) angeordnet ist und die dritte Schicht für Strömungsmedium (74) zwischen der zweiten inneren Schicht (62) und der zweiten äußeren Schicht (58) angeordnet ist.

5

5. Mit Strömungsmedium gefüllte Blase nach Anspruch 4, wobei die Kammern in der ersten Schicht für Strömungsmedium (72) angeordnet sind und die Kammern durch Befestigen der ersten äußeren Schicht (56) an der ersten inneren Schicht (60) gebildet sind.

10

6. Mit Strömungsmedium gefüllte Blase nach Anspruch 4, wobei die erste Schicht für Strömungsmedium (72), die zweite Schicht für Strömungsmedium (76) und die dritte Schicht für Strömungsmedium (74) bezüglich einer Strömungsverbindung voneinander isoliert sind.

15

7. Mit Strömungsmedium gefüllte Blase nach Anspruch 4, wobei Teile der ersten Schicht für Strömungsmedium (72) mit Teilen der dritten Schicht für Strömungsmedium (74) in Strömungsverbindung stehen.

20

25

8. Mit Strömungsmedium gefüllte Blase nach Anspruch 7, wobei die Teile der ersten Schicht für Strömungsmedium (72) an einem Umfang der ersten und der zweiten Schicht für Strömungsmedium (72, 76) angeordnet sind.

30

9. Mit Strömungsmedium gefüllte Blase nach Anspruch 4, wobei die Kammern (A-G) in der zweiten Schicht für Strömungsmedium (76) angeordnet sind und die Kammern (A-G) durch Befestigen der ersten inneren Schicht (60) an der zweiten inneren Schicht (62) gebildet sind.

35

10. Mit Strömungsmedium gefüllte Blase nach Anspruch 9, wobei die Drücke in den Kammern (A-G) größer sind, als die Drücke in der ersten Schicht für Strömungsmedium (72) und der dritten Schicht für Strömungsmedium (74).

40

11. Mit Strömungsmedium gefüllte Blase nach Anspruch 9, wobei die Drücke in den Kammern, welche in Umfangsteilen der zweiten Schicht für Strömungsmedium (76) angeordnet sind, größer sind, als die Drücke in Kammern, die in inneren Teilen der zweiten Schicht für Strömungsmedium (76) angeordnet sind.

45

12. Verfahren zum Herstellen einer mit Strömungsmedium gefüllten Blase für eine Schuhsohle, wobei das Verfahren folgende Schritte aufweist:

- Bereitstellen einer ersten äußeren Sperrfolie (56) und einer zweiten äußeren Sperrfolie (58);
- Zwischensetzen eines Paares inneren Sperrfolie (60, 62) zwischen die erste und zweite äu-

55

- ßere Folie (56, 58);
- Aufbringen eines Musters aus Klebverhinderungsmaterial entweder auf die gegenüberliegenden Seiten der inneren Folien (60,62) oder auf die inneren Seiten der äußeren Folien (56, 58);
 - Zusammenfügen der ersten und zweiten äußeren Folien (56, 58) mit den inneren Folien (60, 62) entlang ihres Umfangs zur Bildung einer Hülle mit zwischengesetzten inneren Folien (60, 62);
 - Zusammenfügen der äußeren Folien (56, 58) mit den inneren Folien (60, 62) in Bereichen, welche nicht klebverhindert sind; und
 - Zuführen von Strömungsmedium zu der Hülle, so dass die äußeren Folien (56, 58) voneinander weggezogen werden und die inneren Folien (60, 62) als Spannglied wirken, das an den äußeren Folien (56, 58) angebracht ist, um drei Schichten für Strömungsmedium (72, 74, 76) bereitzustellen.
13. Verfahren nach Anspruch 12, wobei der Schritt des Zuführens von Strömungsmedium zu der Hülle das Zuführen von verschiedenen Flüssigkeiten zu den zwei mit Strömungsmedium gefüllten Schichten aufweist, um die Dämpfungs- bzw. Polsterungseigenschaften der Blase in einer vertikalen Richtung zu variieren.
14. Verfahren nach Anspruch 12, wobei der Schritt der Anwendung von Klebverhinderungsmaterial die Anwendung eines Musters von Klebverhinderungsmaterial umfasst, um zwei gesonderte Teilkammern in einer mit Strömungsmedium gefüllten Schicht zu bilden.
15. Verfahren nach Anspruch 14, wobei der Schritt des Zuführens von Strömungsmedium das Zuführen eines Gases zu der Hülle und das Unterdrucksetzen der Teilkammern auf verschiedene Drücke aufweist.
16. Verfahren nach Anspruch 12, wobei der Schritt des Zuführens von Strömungsmedium das Zuführen eines Gases aufweist, um die mit Strömungsmedium gefüllten Schichten mit Druck zu beaufschlagen.

Revendications

1. Vessie remplie de fluide pour une semelle de chaussure comprenant :
- une enveloppe formée par une première couche extérieure (56) et une seconde couche extérieure (58) d'un matériau de film de barrage scellées le long de leurs périphéries et
 - une première couche intérieure (60) et une se-

conde couche intérieure (62) de matériau de film de barrage positionné entre la première couche extérieure (56) et la seconde couche extérieure (58),

- les couches intérieures (60, 62) divisant l'enveloppe en une première couche de fluide (72), une seconde couche de fluide (76) et une troisième couche de fluide (74) située entre la première couche extérieure (56) et la seconde couche extérieure (58),
- au moins deux des couches de fluide (72, 74, 76) contenant des fluides avec différentes pressions,

caractérisée par

- au moins l'une des couches de fluide (72, 74, 76) étant sous-divisée en au moins deux chambres (A-G) isolées contre la communication fluide l'une avec l'autre,
- les chambres (A-G) contenant des fluides avec différentes pressions,
- et une pluralité de sites de connexion (64, 66, 68, 70) qui relie la première couche extérieure (56) à la première couche intérieure (60), la première couche intérieure (60) à la seconde couche intérieure (62) et la seconde couche intérieure (62) à la seconde couche extérieure (58).

2. Vessie remplie de fluide selon la revendication 1 dans laquelle les fluides sont des gaz.
3. Vessie remplie de fluide selon la revendication 1 dans laquelle la première couche intérieure (60) est située adjacente à la première couche extérieure (56) et la seconde couche intérieure (62) est située adjacente à la seconde couche extérieure (58).
4. Vessie remplie de fluide selon la revendication 2 dans laquelle la première couche de fluide (72) est située entre la première couche extérieure (56) et la première couche intérieure (60), la seconde couche de fluide (76) est située entre la première couche intérieure (60) et la seconde couche intérieure (62) et la troisième couche de fluide (74) est située entre la seconde couche intérieure (62) et la seconde couche extérieure (58).
5. Vessie remplie de fluide selon la revendication 4 dans laquelle les chambres sont situées dans la première couche de fluide (72), les chambres étant formées en attachant la première couche extérieure (56) à la première couche intérieure (60).
6. Vessie remplie de fluide selon la revendication 4 dans laquelle la première couche de fluide (72), la seconde couche de fluide (76) et la troisième couche de fluide (74) sont isolées contre la communication

- fluide l'une avec l'autre.
7. Vessie remplie de fluide selon la revendication 4 dans laquelle des portions de la première couche de fluide (72) sont en communication fluide avec des portions de la troisième couche de fluide (74). 5
8. Vessie remplie de fluide selon la revendication 7 dans laquelle des portions de la première couche de fluide (72) sont situées sur une périphérie de la première et de la seconde couche de fluide (72, 76). 10
9. Vessie remplie de fluide selon la revendication 4 dans laquelle les chambres (A-G) sont situées dans la seconde couche de fluide (76), les chambres (A-G) étant formées en attachant la première couche intérieure (60) à la seconde couche intérieure (62). 15
10. Vessie remplie de fluide selon la revendication 9 dans laquelle les pressions dans les chambres (A-G) sont plus grandes que les pressions dans la première couche de fluide (72) et la troisième couche de fluide (74). 20
11. Vessie remplie de fluide selon la revendication 9 dans laquelle les pressions dans les chambres situées dans les portions périphériques de la seconde couche de fluide (76) sont plus élevées que les pressions dans les chambres dans les portions intérieures de la seconde couche de fluide (76). 25
30
12. Procédé pour fabriquer une vessie remplie de fluide pour une semelle de chaussure comprenant les étapes de : 35
- fournir un premier film de barrage extérieur (56) et un second film de barrage extérieur (58) ;
 - interposer une paire de films de barrage intérieurs (60, 62) entre le premier et le second film extérieurs (56, 58) ; 40
 - appliquer un modèle de matériau inhibiteur d'adhérence à l'un ou l'autre des côtés opposés des films intérieurs (60, 62) ou des côtés intérieurs des films extérieurs (56, 58) ;
 - faire adhérer les premier et second films extérieurs (56, 58) et les films intérieurs (60, 62) ensemble le long de leurs périphéries pour former une enveloppe avec les films intérieurs interposés (60, 62) ; 45
 - faire adhérer les films extérieurs (56, 58) aux films intérieurs (60, 62) dans des zones qui ne sont pas inhibées à l'adhérence et 50
 - alimenter l'enveloppe en fluide si bien que les films extérieurs (56, 58) se détacheront l'un de l'autre et les films intérieurs (60, 62) agiront comme un membre élastique attaché aux films extérieurs (56, 58) pour fournir trois couches remplies de fluide (72, 74, 76). 55
13. Procédé selon la revendication 12 dans lequel l'étape d'alimenter l'enveloppe en fluide comprend l'alimentation en différents fluides aux deux couches remplies de fluide pour faire varier les caractéristiques d'amortissement de la vessie dans un sens vertical.
14. Procédé selon la revendication 12 dans lequel l'étape d'appliquer un matériau inhibiteur d'adhérence comprend l'application d'un modèle de matériau inhibiteur d'adhérence pour former deux sous-chambres discrètes dans une couche remplie de fluide.
15. Procédé selon la revendication 14 dans lequel l'étape d'alimentation en fluide comprend l'alimentation de l'enveloppe avec un gaz et la pressurisation des sous-chambres à différentes pressions.
16. Procédé selon la revendication 12 dans lequel l'étape d'alimentation en fluide comprend l'alimentation avec un gaz pour pressuriser les couches remplies de fluide.

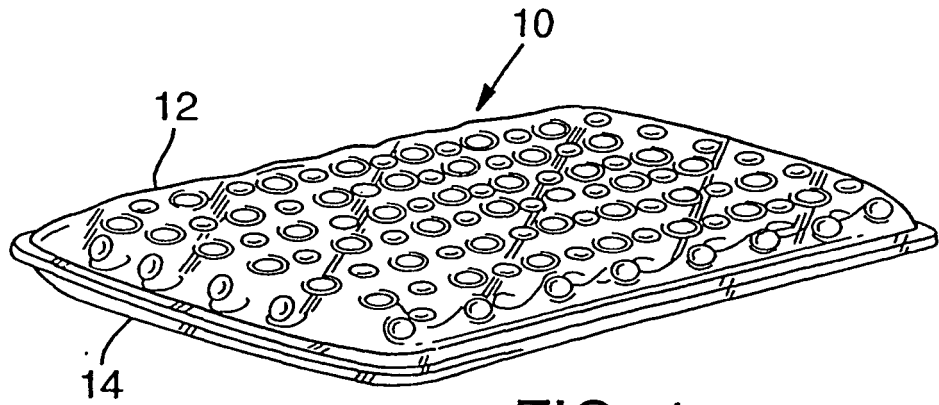

FIG. 1

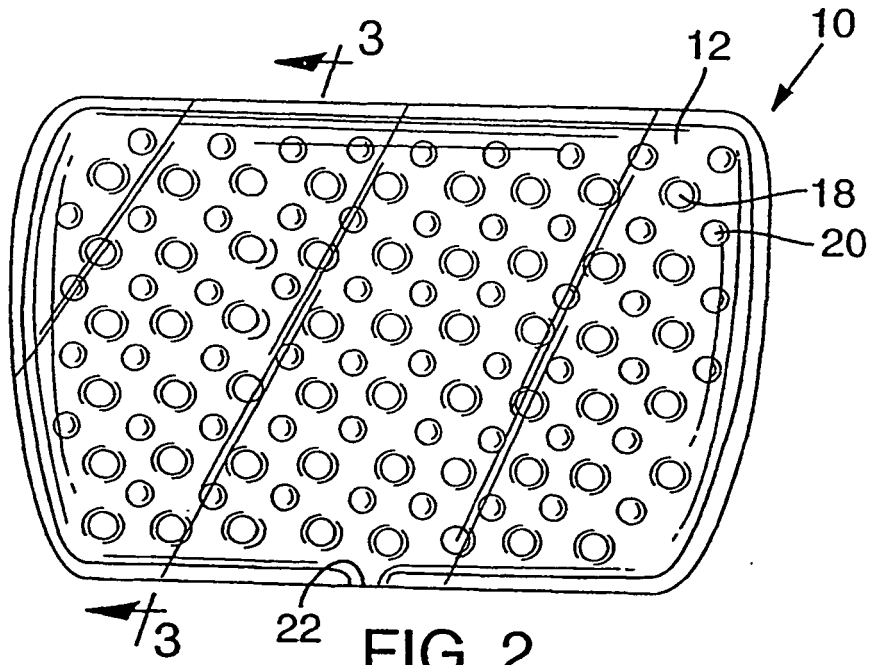

FIG. 2

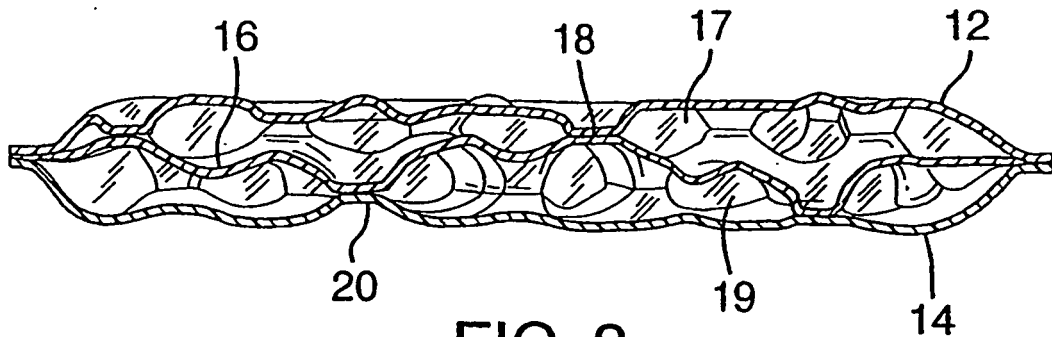

FIG. 3

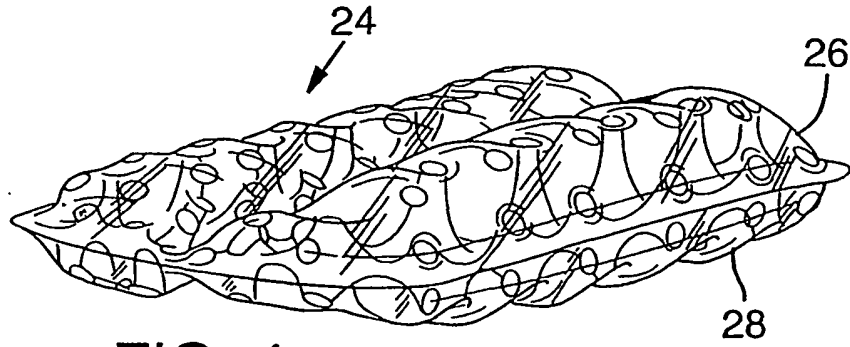

FIG. 4

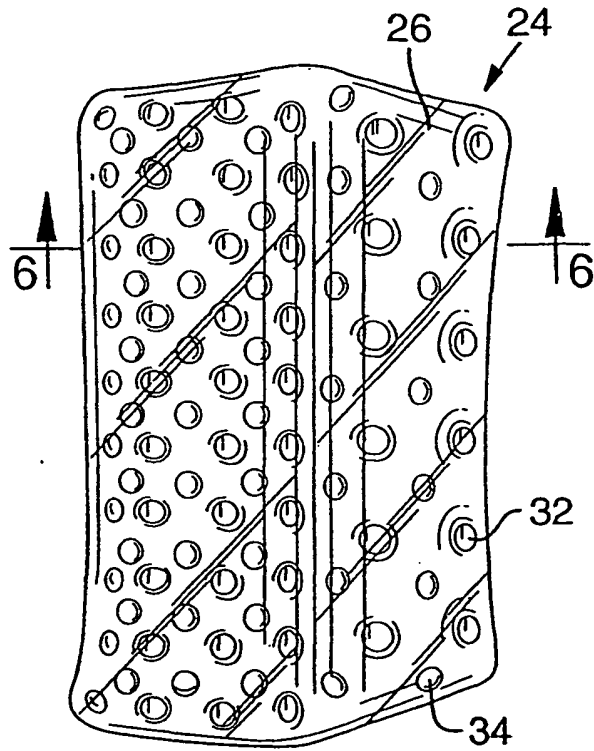

FIG. 5

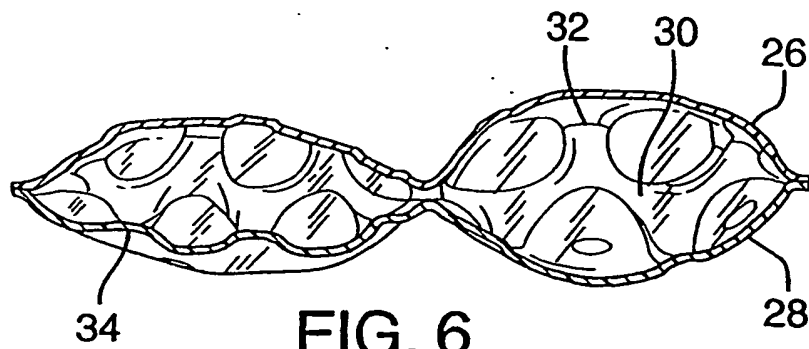

FIG. 6

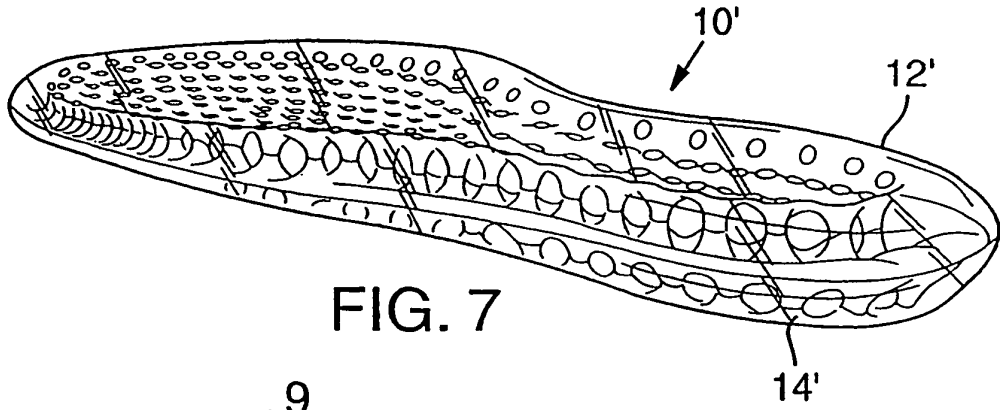

FIG. 7

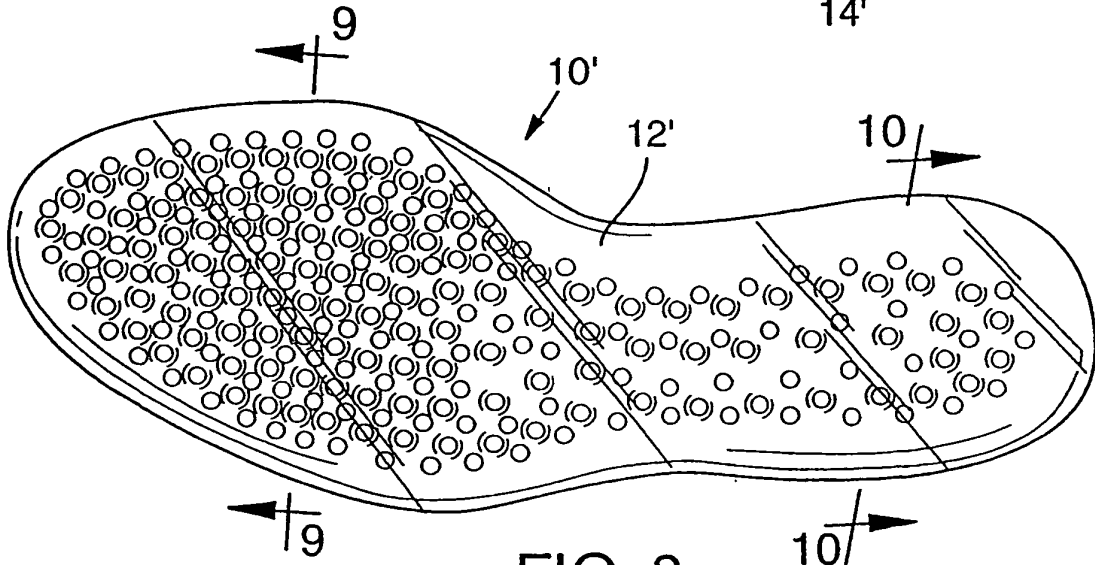

FIG. 8

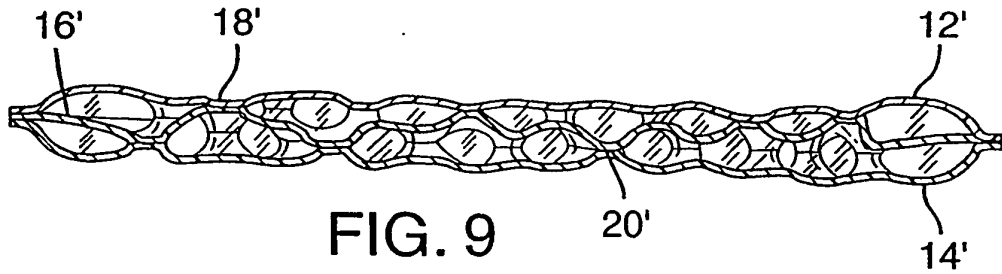

FIG. 9

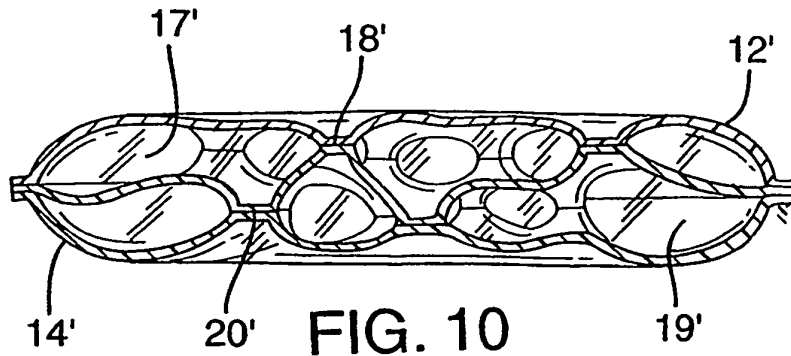

FIG. 10

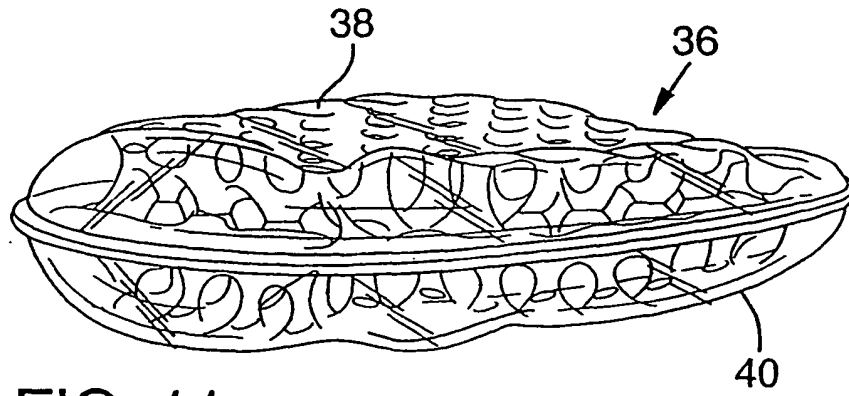

FIG. 11

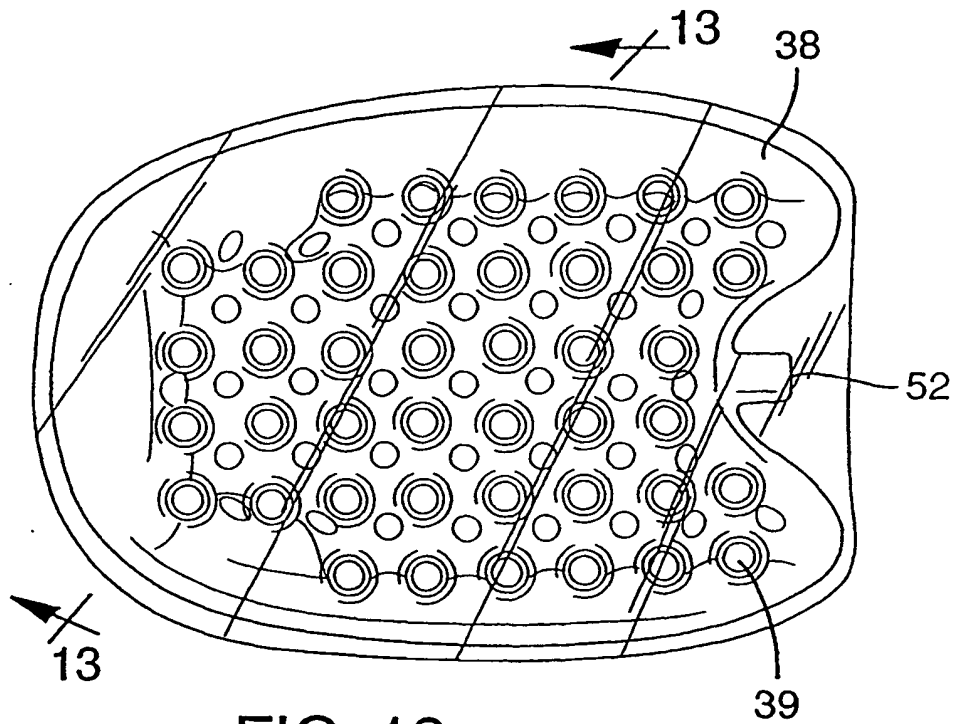

FIG. 12

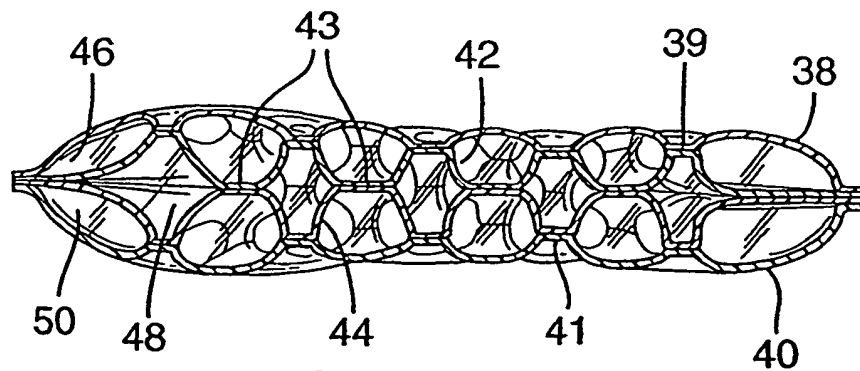

FIG. 13

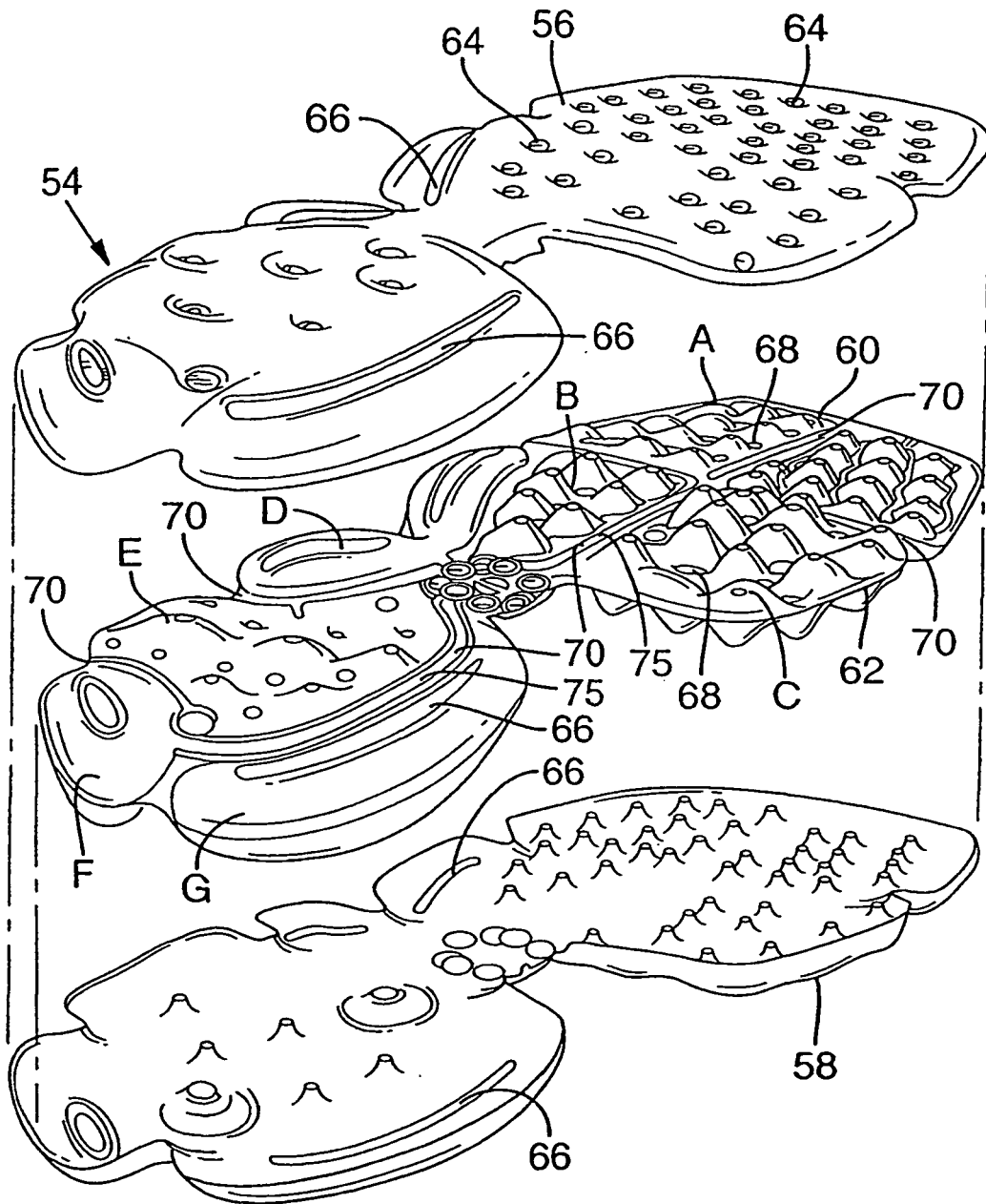

FIG. 14

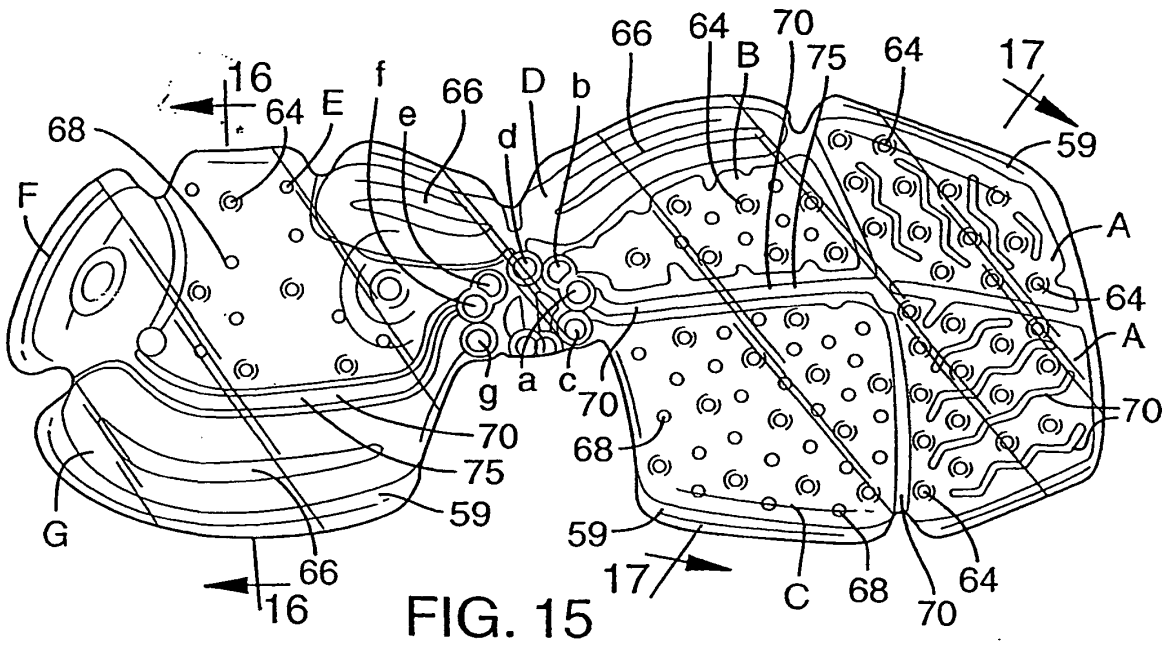

FIG. 15

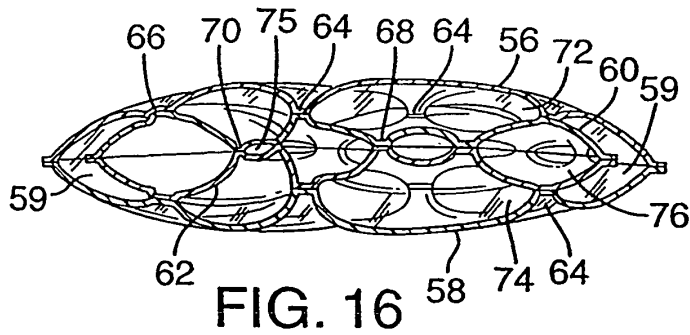

FIG. 16

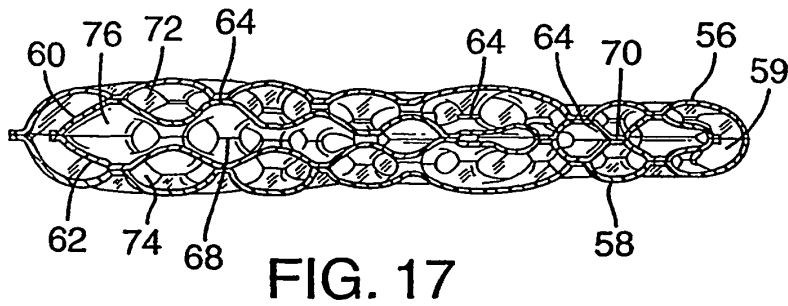

FIG. 17

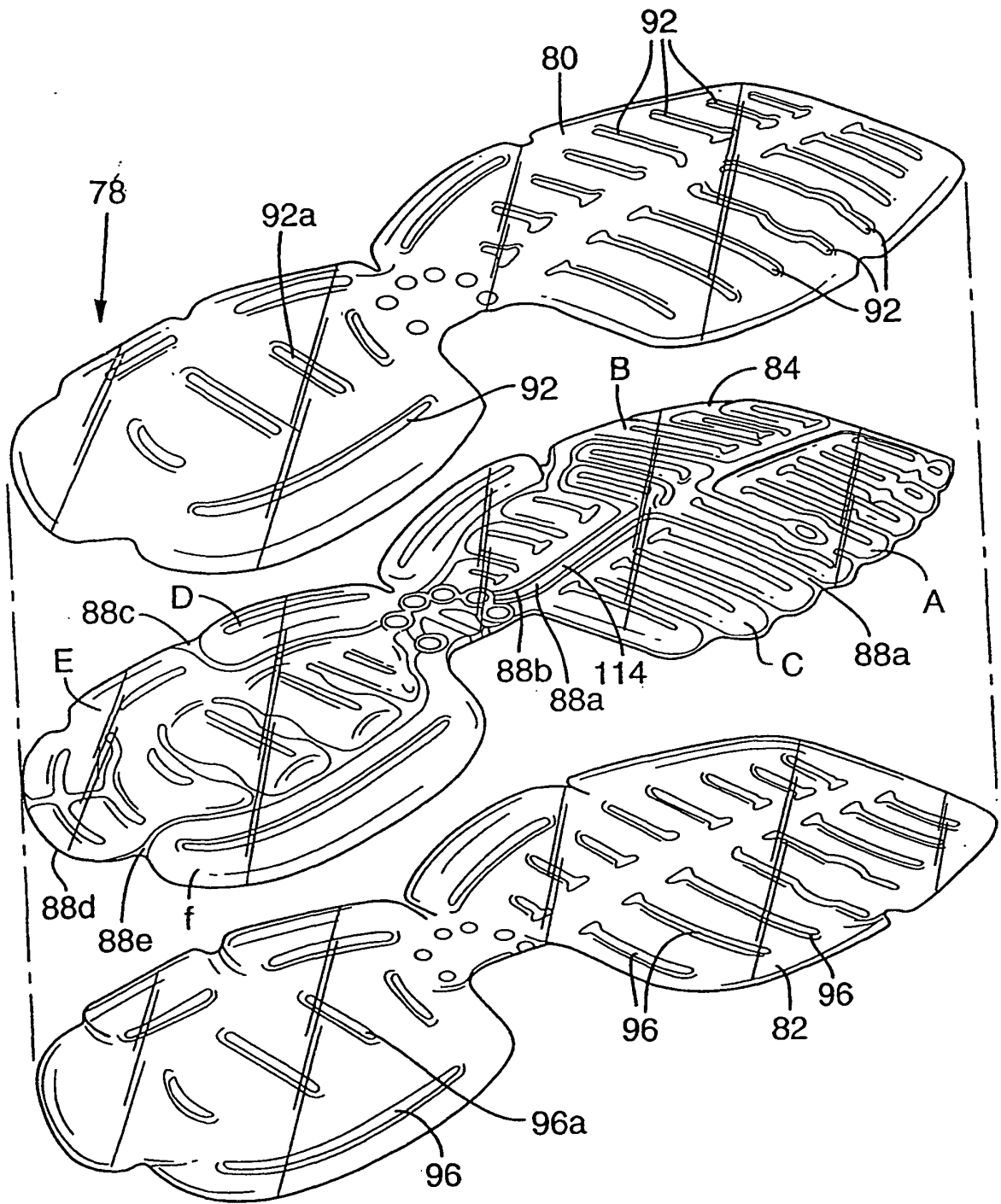

FIG. 18

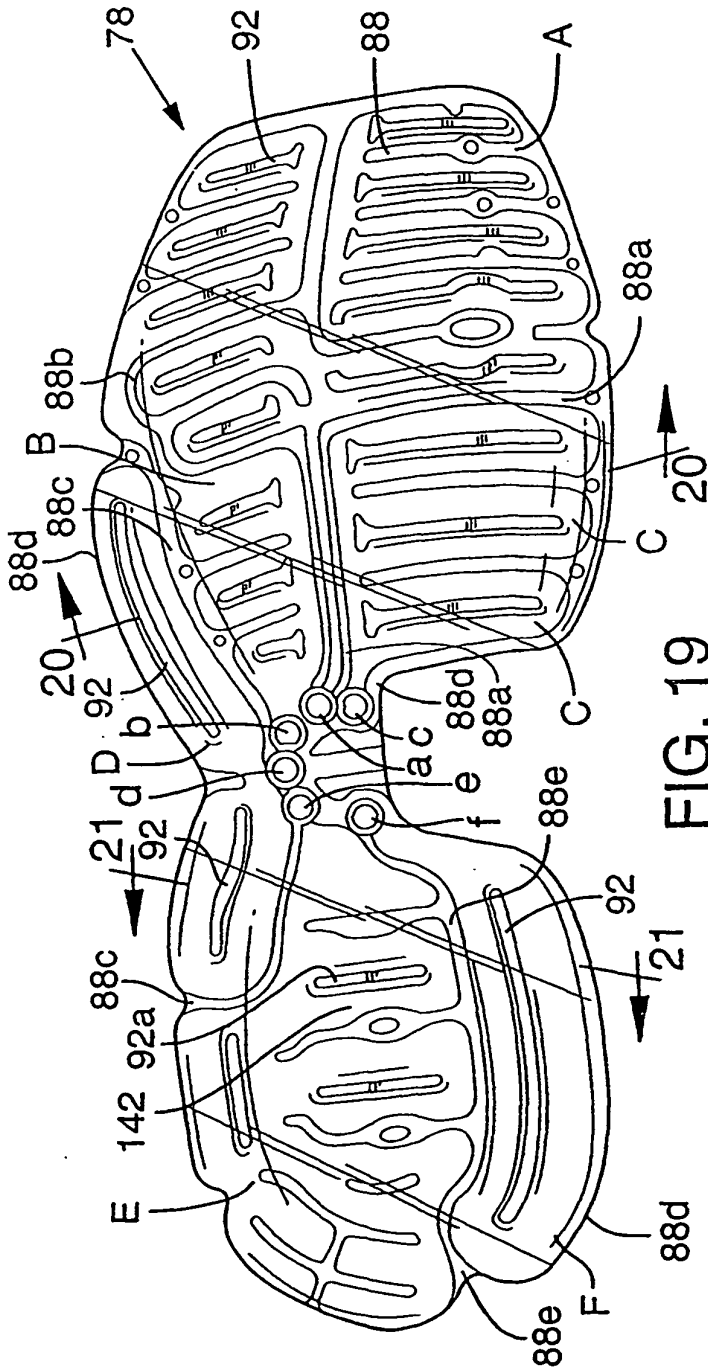

FIG. 19

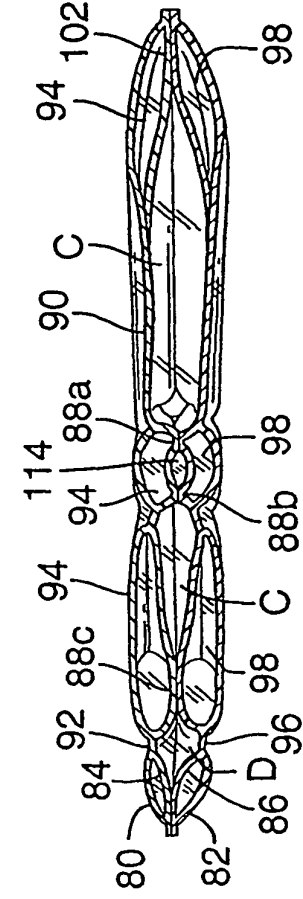

FIG. 20

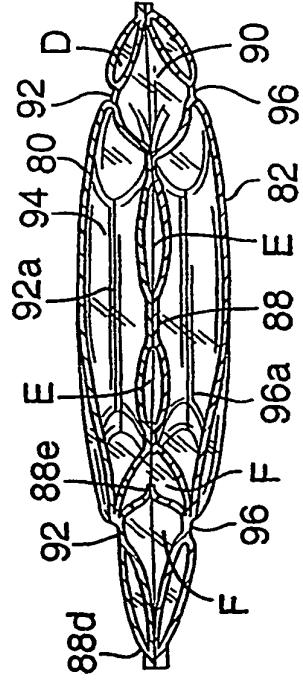

FIG. 21

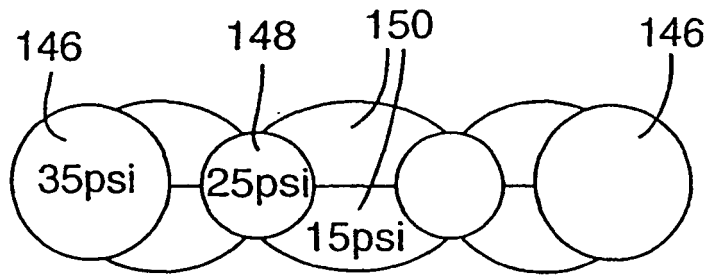

FIG. 22

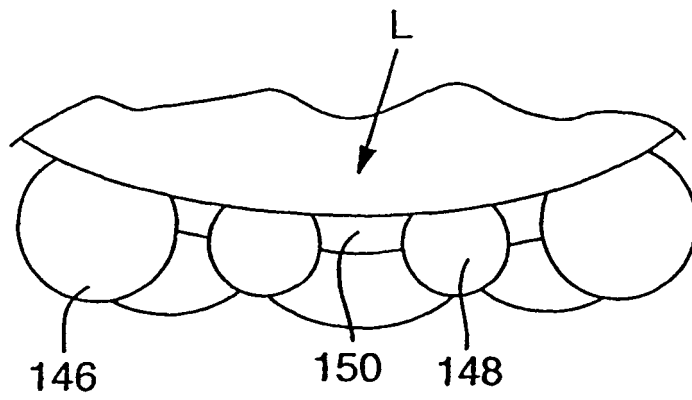

FIG. 23

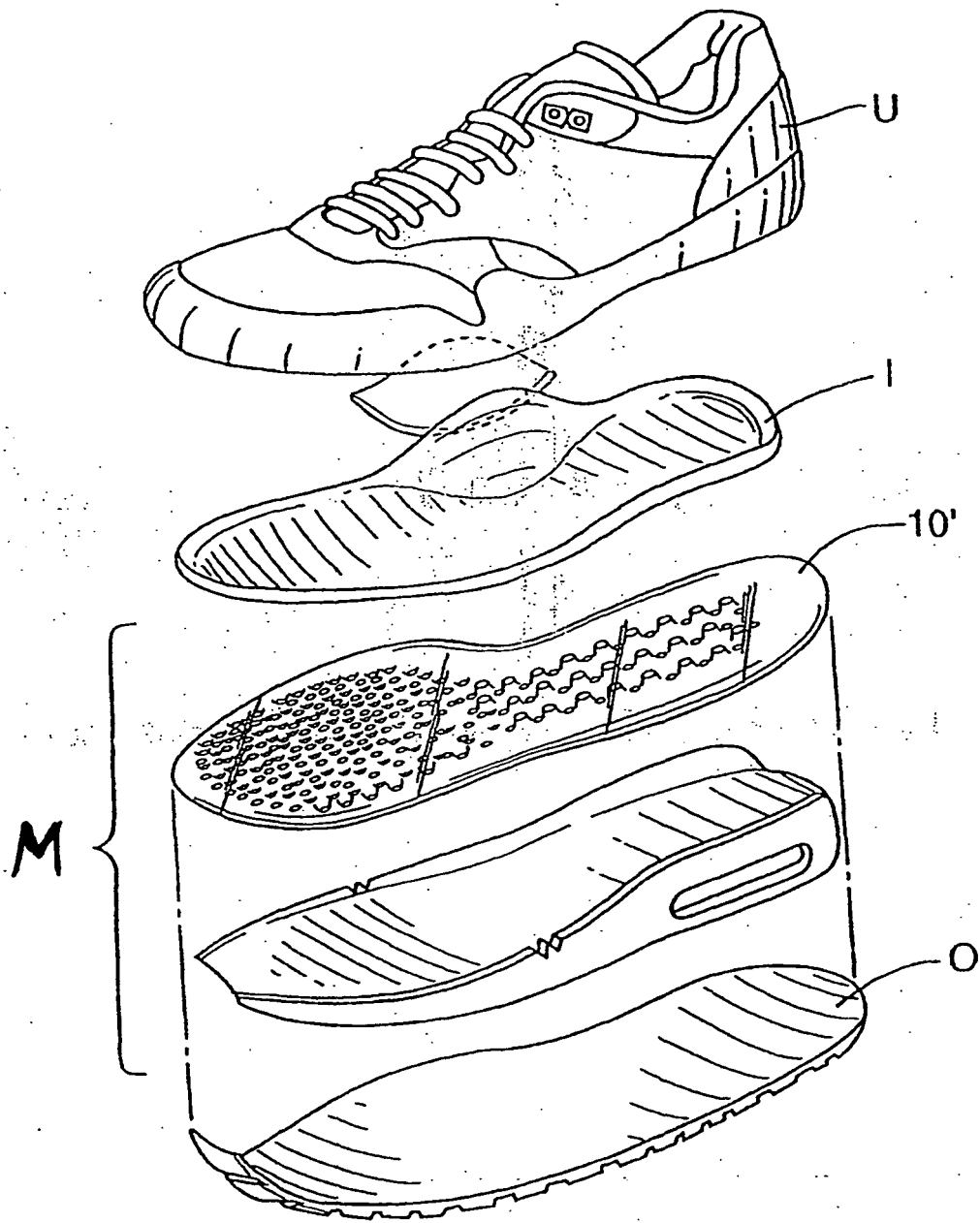

FIG. 24

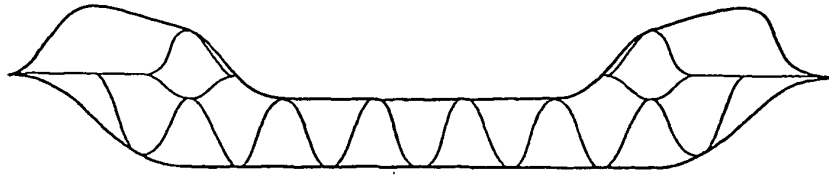

FIG. 25A

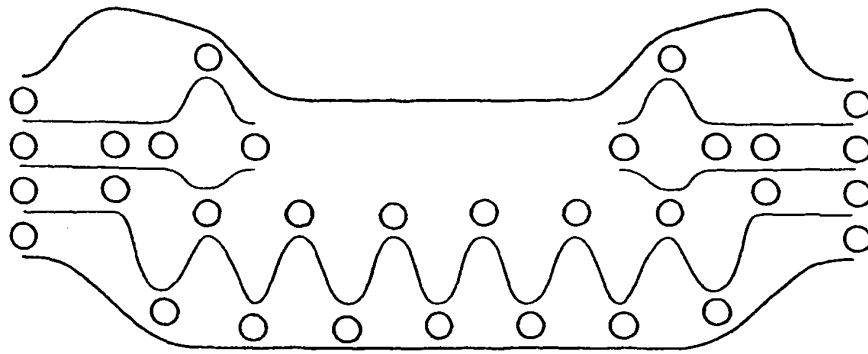

FIG. 25B

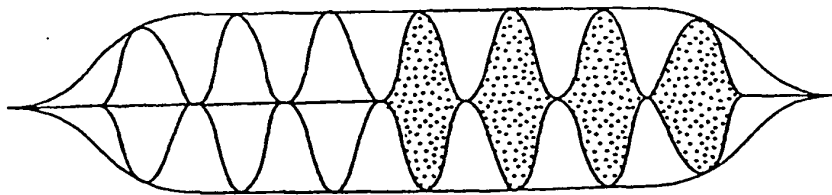

FIG. 26A

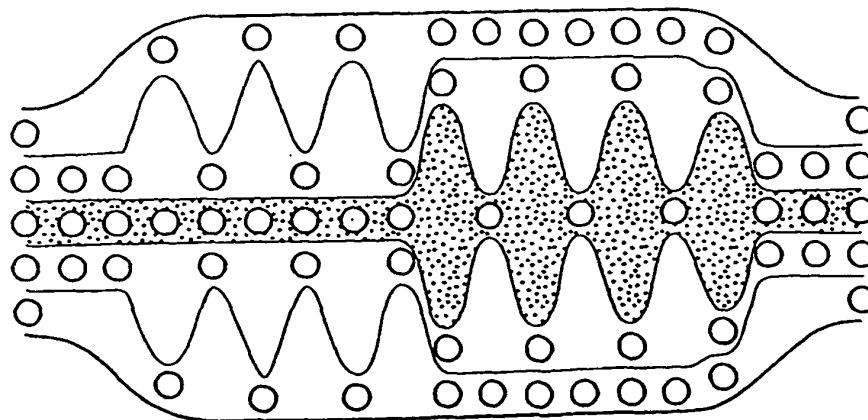

FIG. 26B

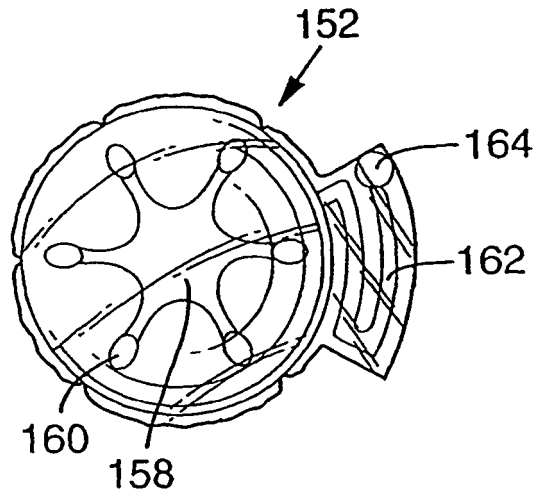

FIG. 27

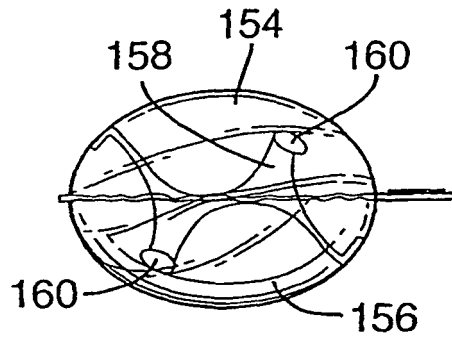

FIG. 28

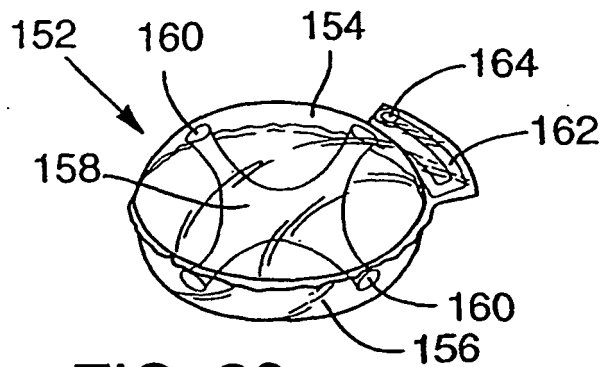

FIG. 29

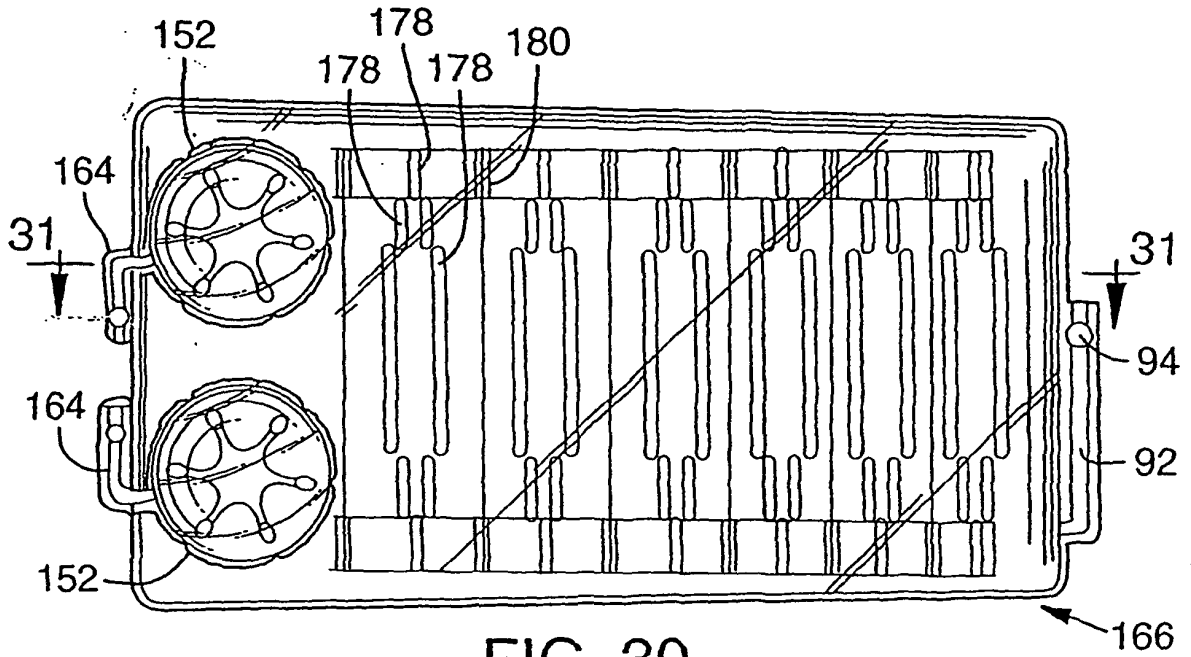

FIG. 30

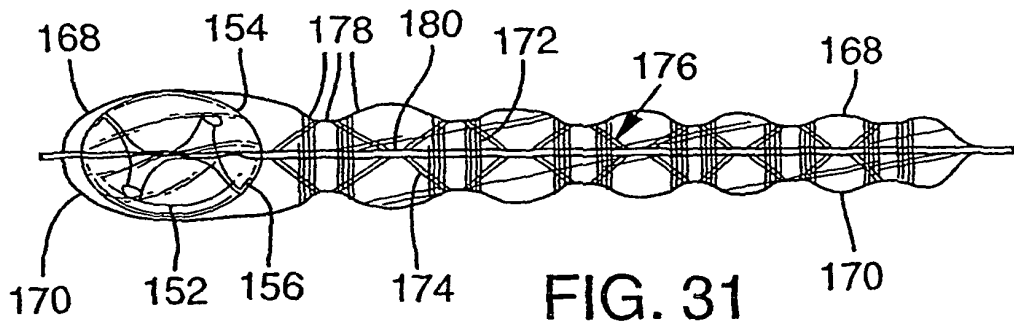

FIG. 31

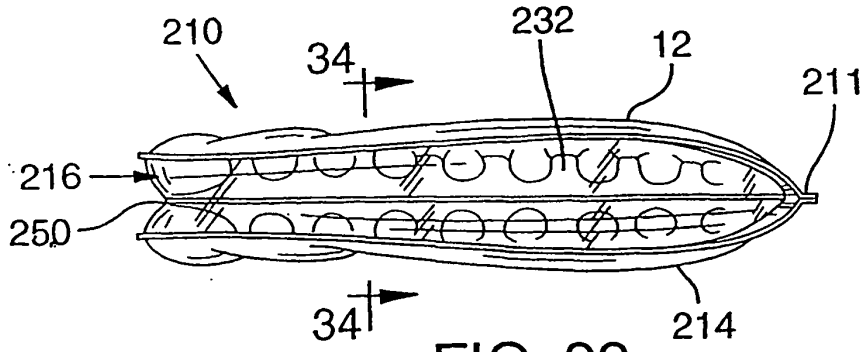

FIG. 32

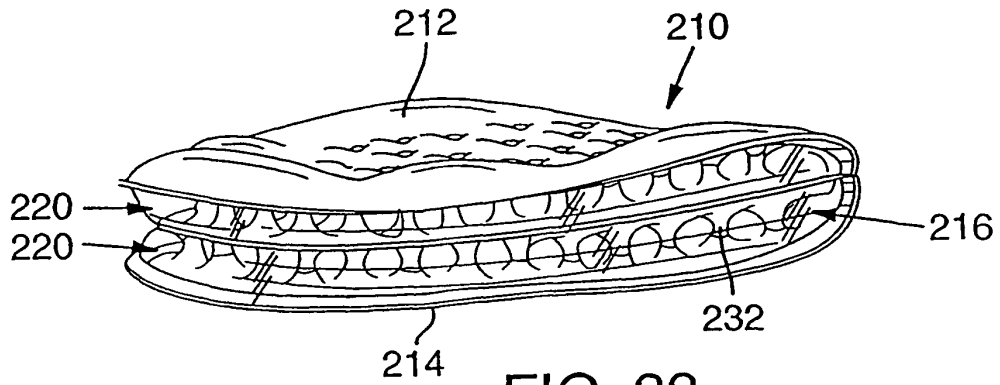

FIG. 33

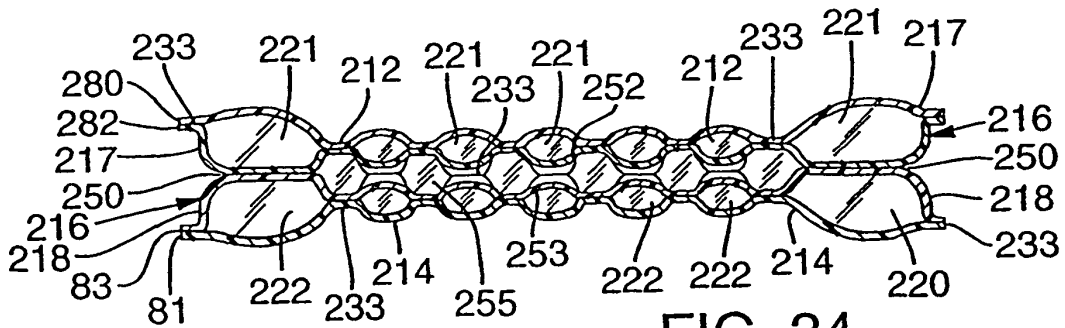

FIG. 34

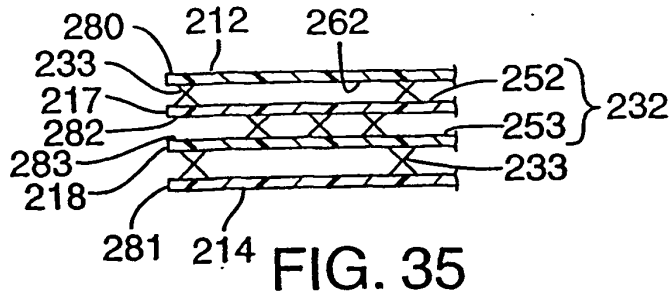

FIG. 35

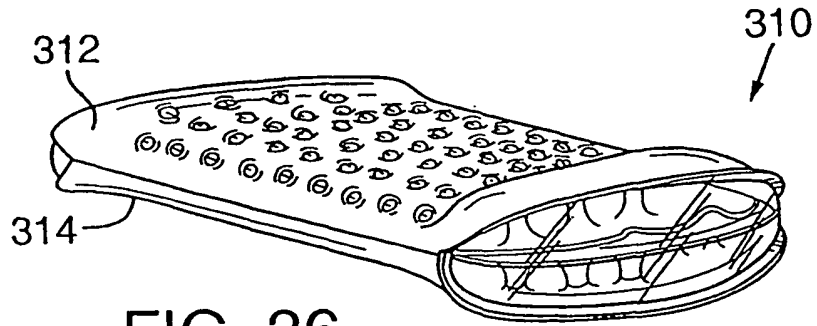

FIG. 36

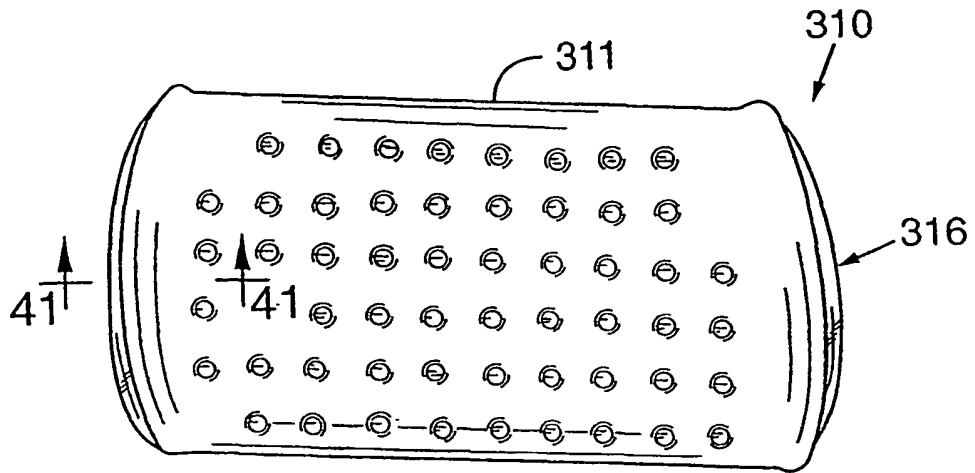

FIG. 37

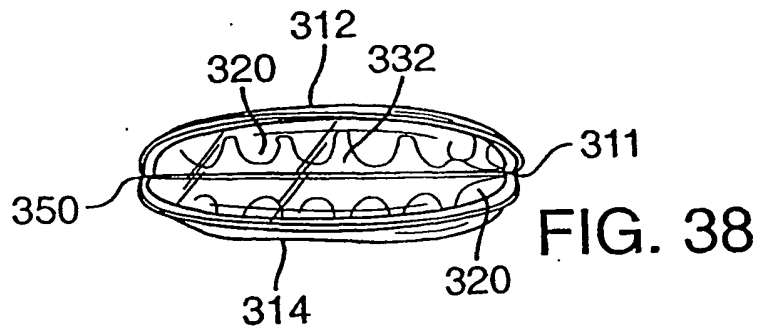

FIG. 38

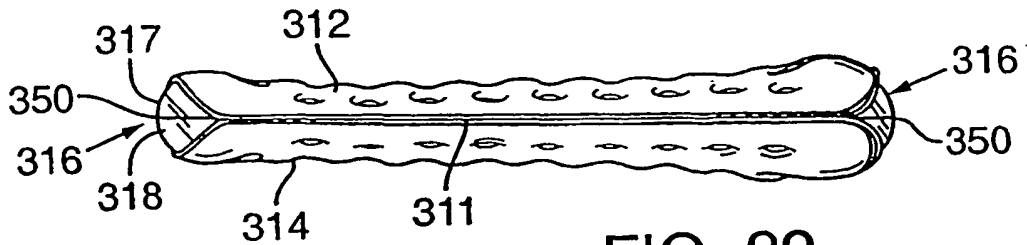

FIG. 39

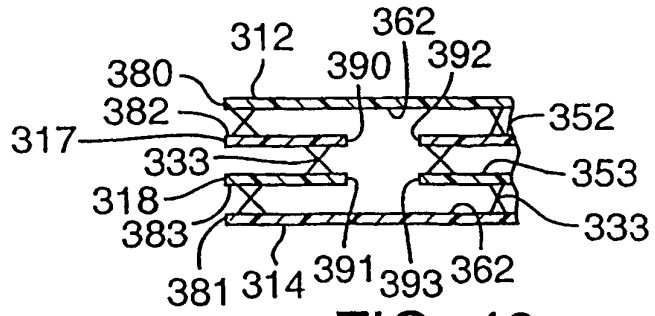

FIG. 40

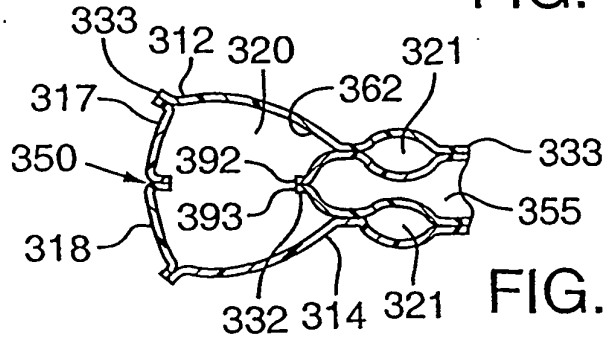

FIG. 41

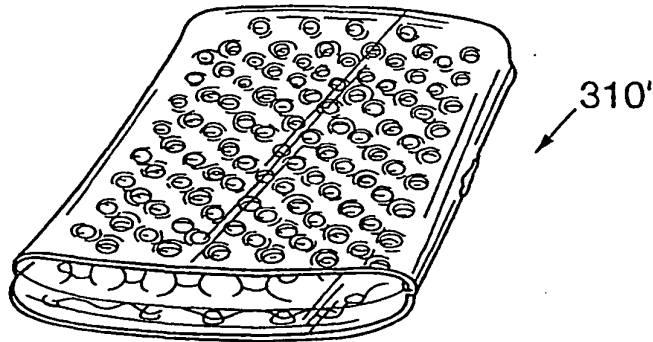

FIG. 42

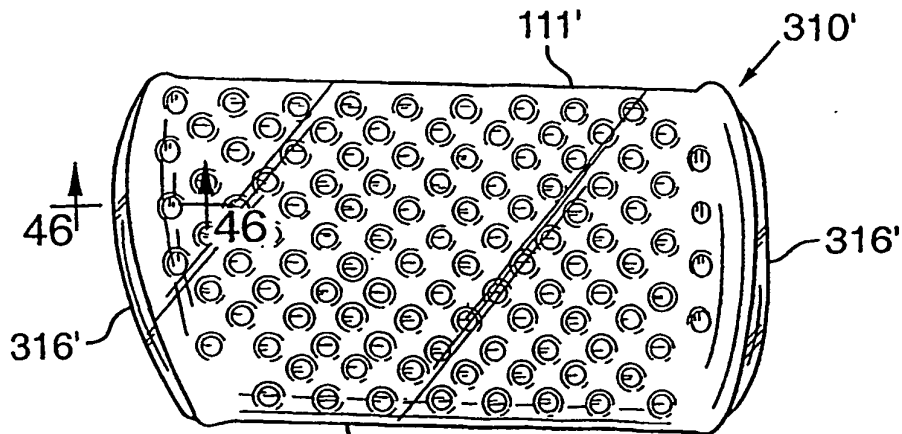

FIG. 43

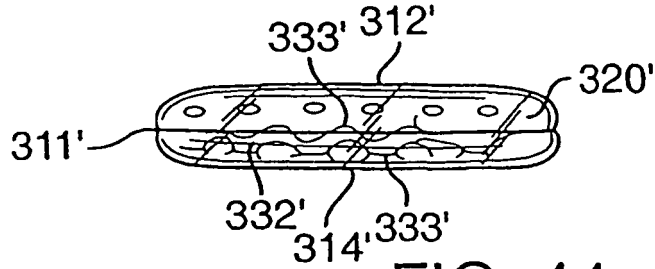

FIG. 44

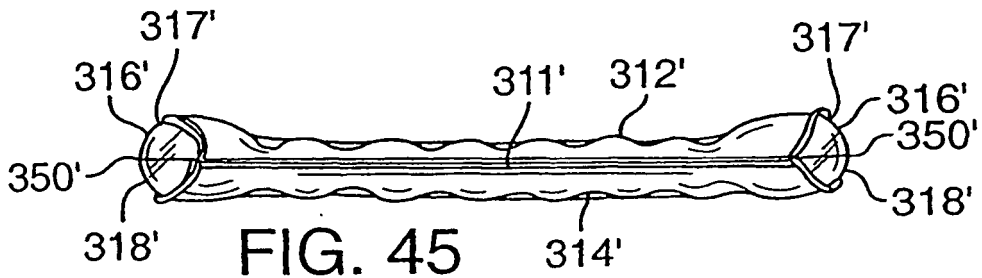

FIG. 45

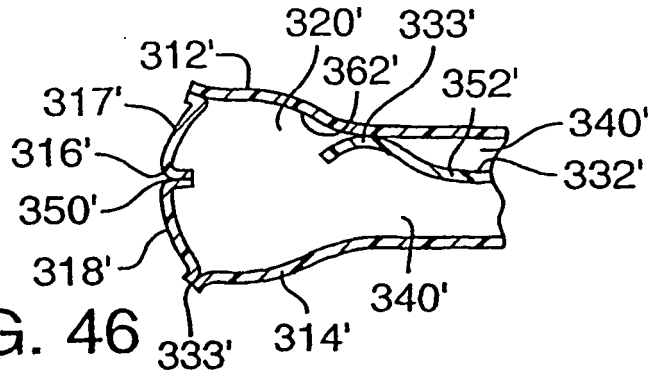

FIG. 46

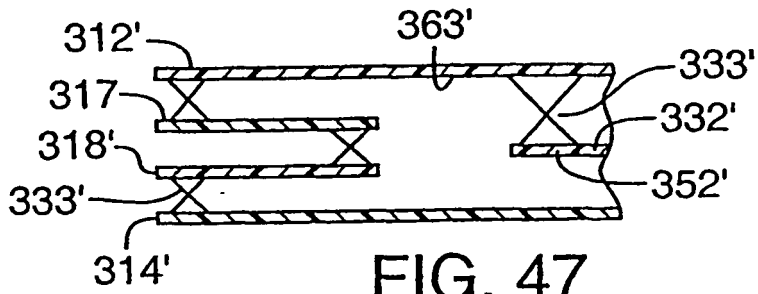
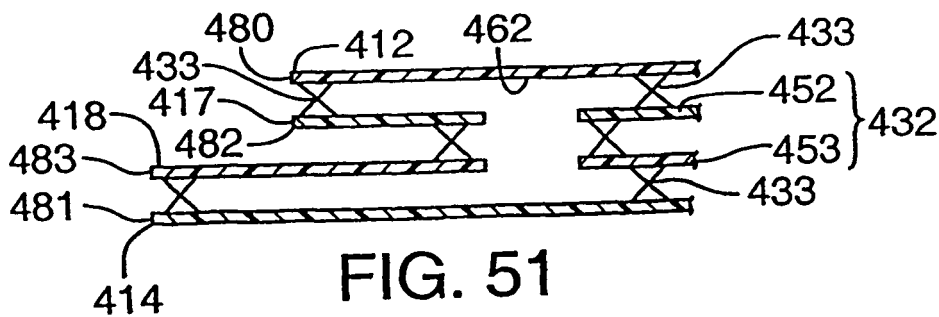
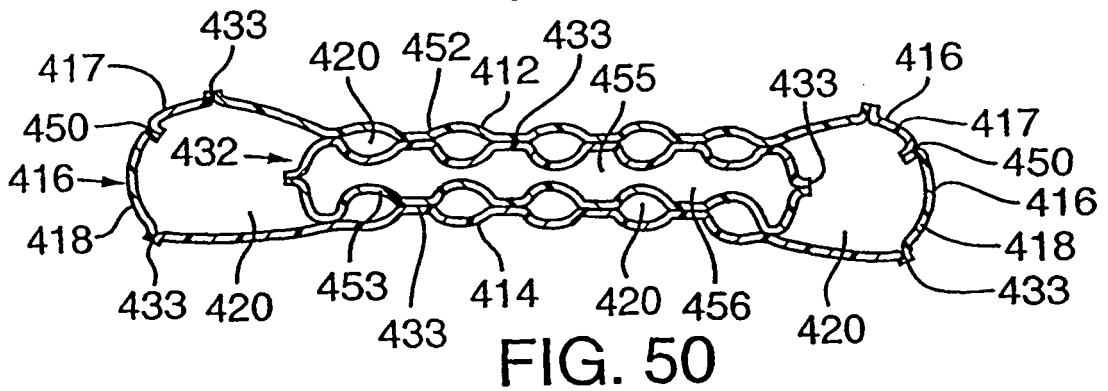
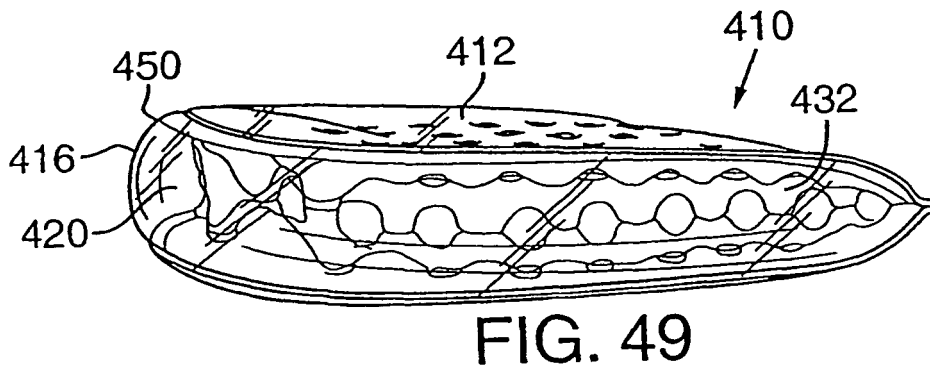
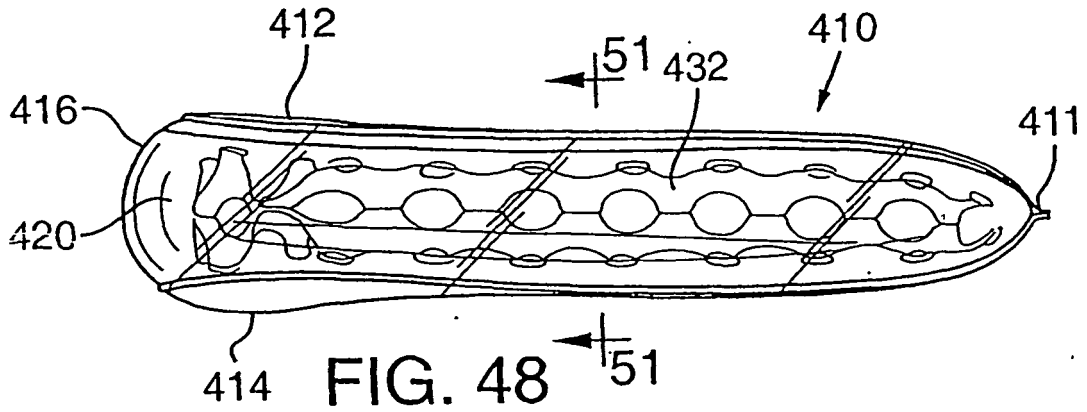

FIG. 47



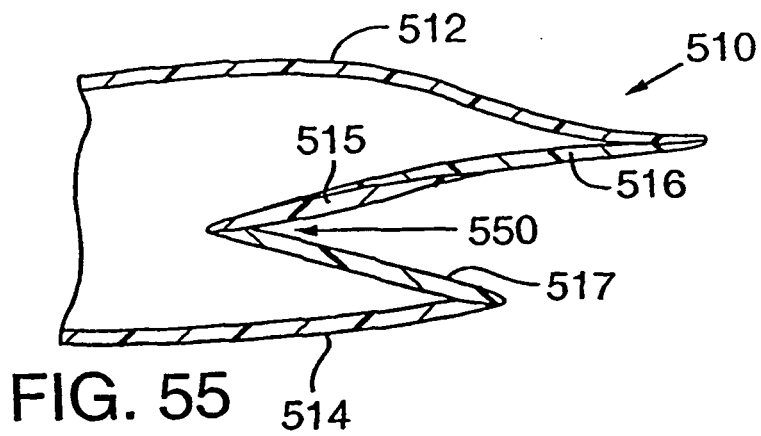
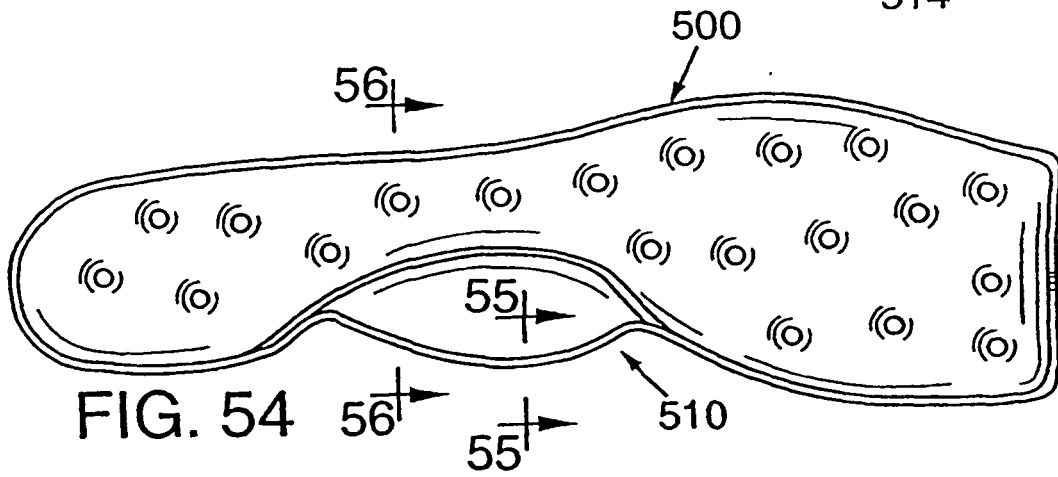
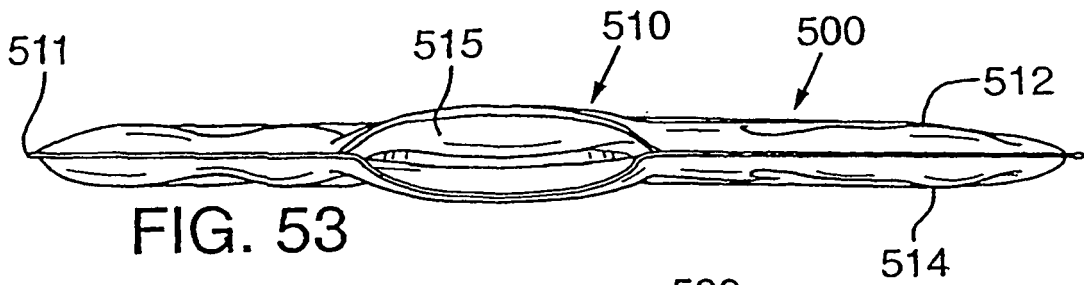
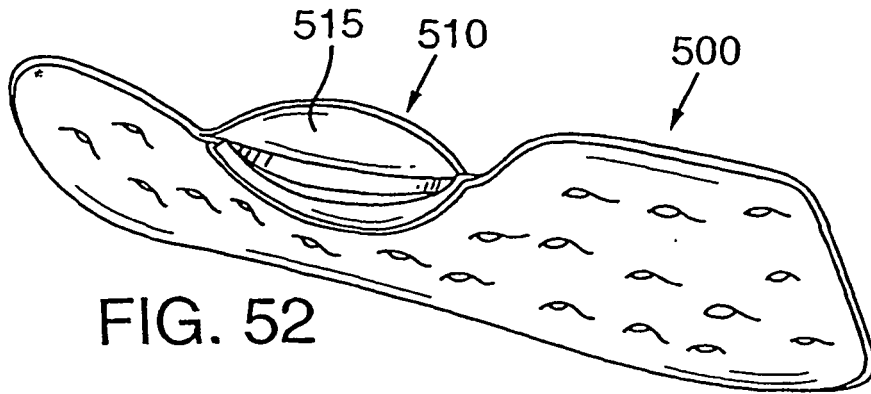

FIG. 56

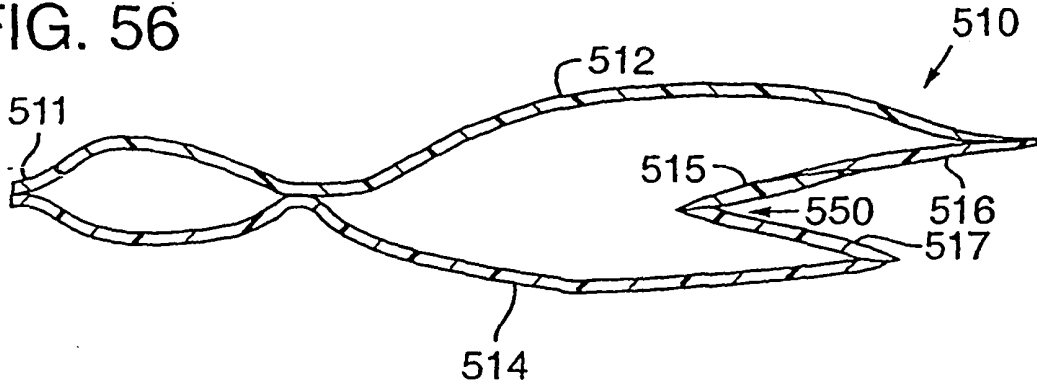

FIG. 57A

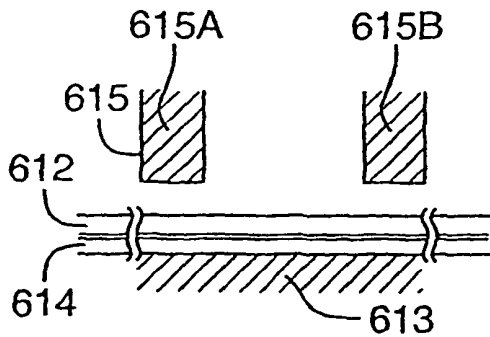

FIG. 57B

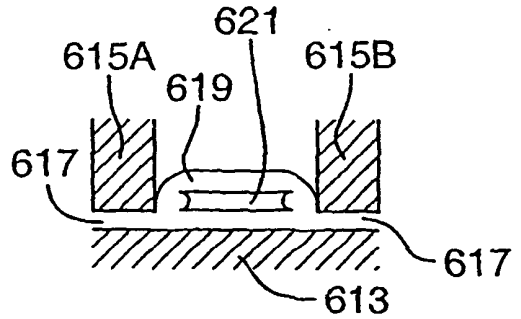

FIG. 57C

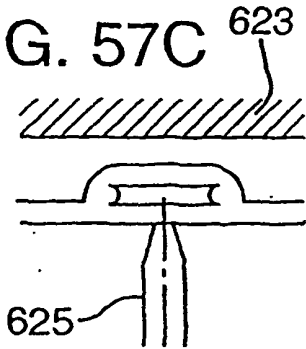

FIG. 57D

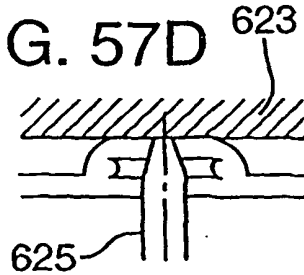

FIG. 57E

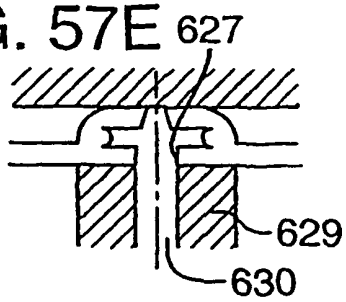

FIG. 57F

