

G. D. HAWORTH.
SEEDING MACHINE.

(Application filed Dec. 16, 1898.)

(No Model.)

4 Sheets—Sheet 1.

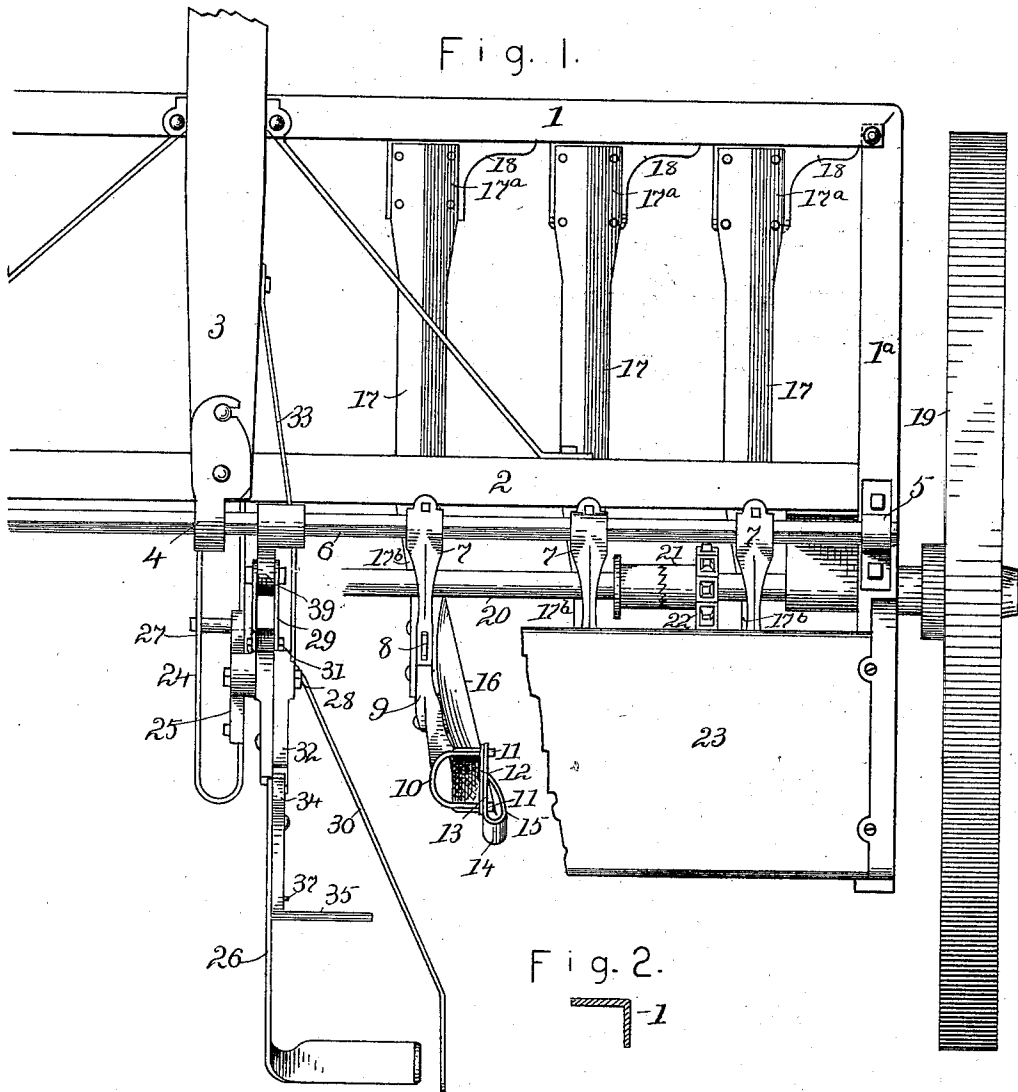

Fig. 2.
-1

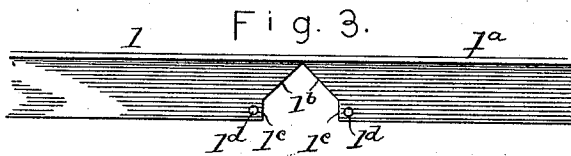
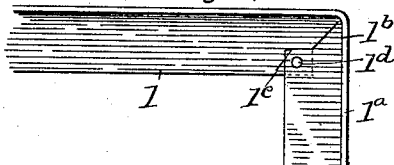

Fig. 3.

Attest

Nora Graham
Ema Graham.

Fig. 4.



INVENTOR,
Geo. D. Haworth
by *L. P. Graham*
his attorney.

G. D. HAWORTH.
SEEDING MACHINE.

(Application filed Dec. 16, 1898.)

(No Model.)

Fig. 5.

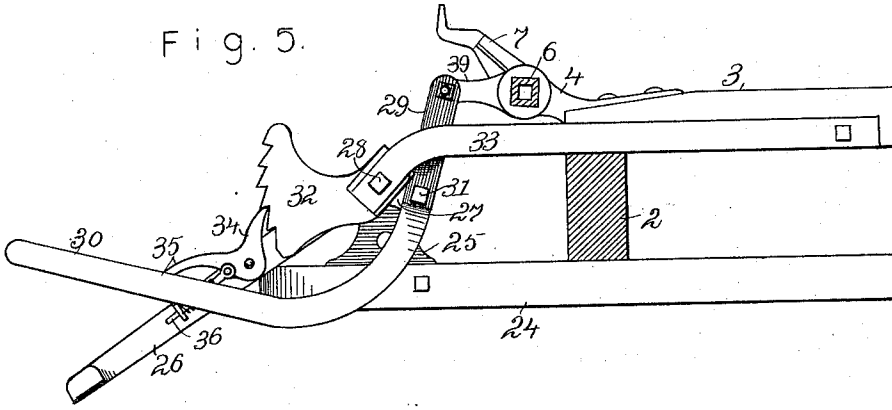

Fig. 6.

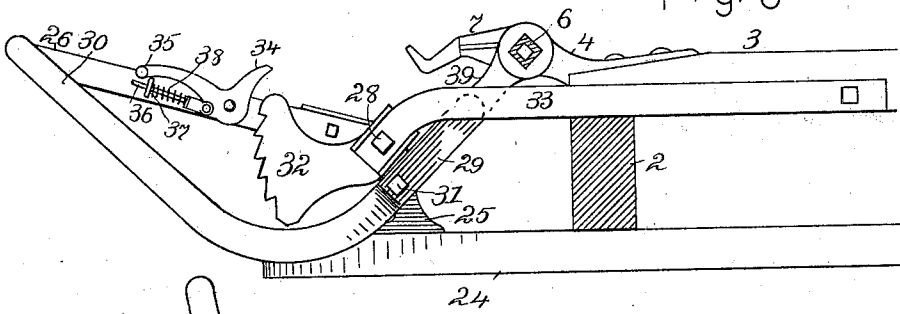
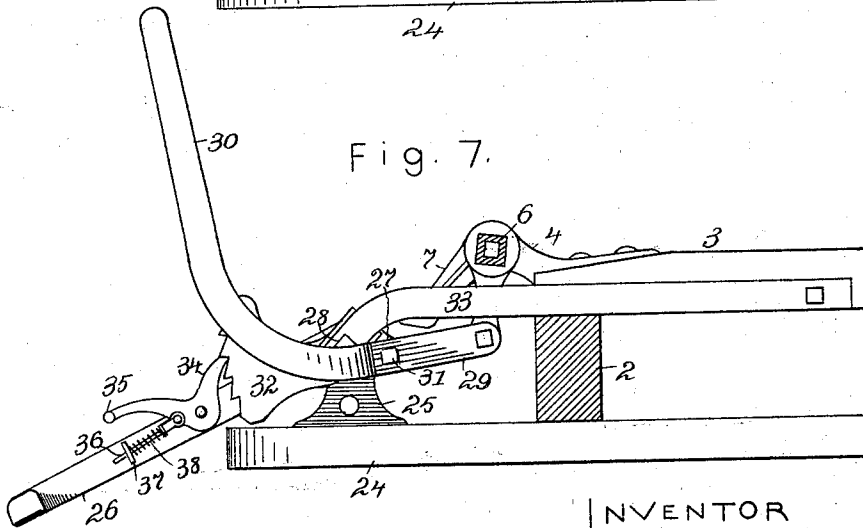

Fig. 7.



Attest

Nora Graham.

Ana Graham.

INVENTOR
Geo. D. Haworth
by L. P. Graham
his attorney

No. 627,116.

Patented June 20, 1899.

G. D. HAWORTH.
SEEDING MACHINE.

(Application filed Dec. 16, 1898.)

(No Model.)

4 Sheets—Sheet 3.

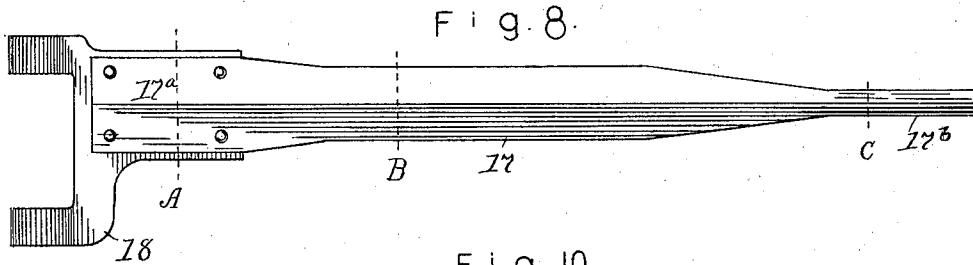

Fig. 10.

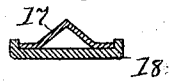

Fig. 9.

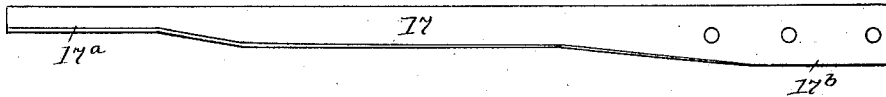

Fig. 11.



Fig. 13.

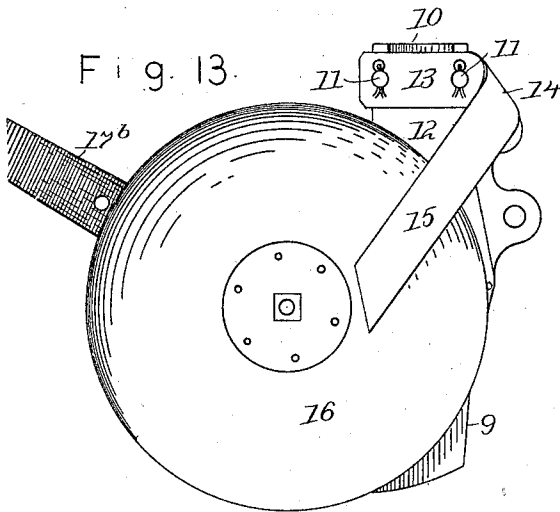
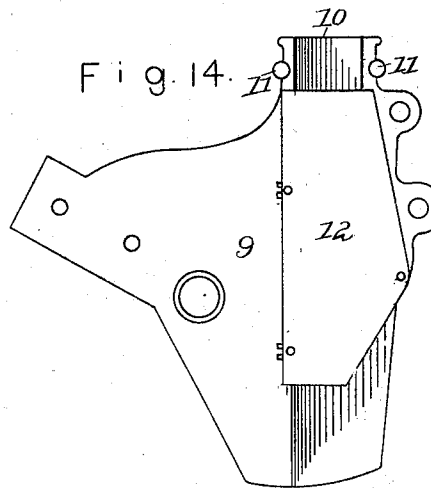

Fig. 14.



Attest

Noa L. Graham.

Ana Graham.

Fig. 12.



INVENTOR
Geo. D. Haworth
by *L. P. Graham*
his attorney

No. 627,116.

Patented June 20, 1899.

G. D. HAWORTH.
SEEDING MACHINE.

(Application filed Dec. 16, 1898.)

(No Model.)

4 Sheets—Sheet 4.

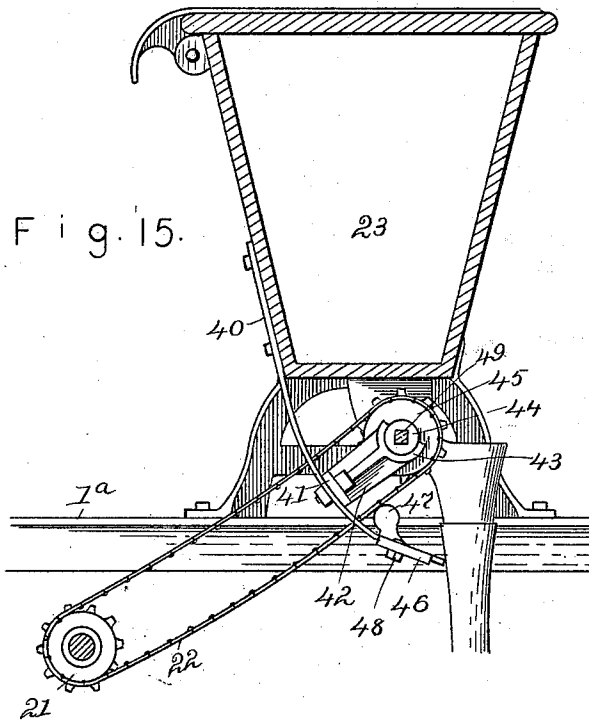
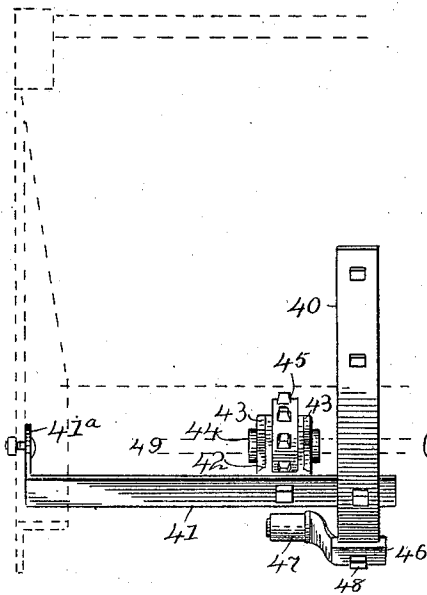

Fig. 15.

Fig. 16.



Attest.
Nora Graham.
Ma Graham.

INVENTOR

Geo. D. Haworth
by L. P. Graham
his attorney

UNITED STATES PATENT OFFICE.

GEORGE D. HAWORTH, OF CHICAGO, ILLINOIS.

SEEDING-MACHINE.

SPECIFICATION forming part of Letters Patent No. 627,116, dated June 20, 1899.

Application filed December 16, 1898. Serial No. 699,506. (No model.)

To all whom it may concern:

Be it known that I, GEORGE D. HAWORTH, of the city of Chicago and State of Illinois, have invented certain new and useful Improvements in Planting-Machines, of which the following is a specification.

This invention in its entirety relates to drill-planters in which disks are used to open the furrows, though some of its features are applicable to various kinds of planting-machines. It is exemplified in the structures hereinafter described and it is defined in the appended claims.

In the drawings forming part of this specification, Figure 1 is a plan of so much of a seed-drill as is needed to show the connection of my invention therewith. Fig. 2 is a cross-section through the principal member of the frame of the drill. Fig. 3 is a representation of the under side of a fragment of the bar of which the principal member of the frame is constructed. Fig. 4 is a representation of the under surface of a corner of the frame. Figs. 5, 6, and 7 are side elevations of the raising and depressing mechanism for the furrow-openers, showing the mode of operation thereof. Fig. 8 is a plan of a draft-bar for a furrow-opener. Fig. 9 is a side elevation of the draft-bar. Fig. 10 is a section on line A in Fig. 8. Fig. 11 is a section on line B in Fig. 8. Fig. 12 is a section on line C in Fig. 8. Fig. 13 is a side elevation of a furrow-opening disk and the frame therefor, showing the construction of the scraper used to clean the disk. Fig. 14 is an elevation of the disk-frame with the disk and scraper-bar removed to expose a plate used to form a side of the shank-tube, through which the seed is delivered. Fig. 15 is a section through the seedbox of the drill, illustrating the means used to support the drill-shaft and hold the sprocket-wheel thereon in alinement with the sprocket-wheel on the main shaft. Fig. 16 is a detail of the support for the drill-shaft, the same being represented as it appears from the front of the drill.

The bar 1 1^a forms the front cross-bar and the side bars of the frame. It is made of angle-iron, one member of which is horizontal and the other vertical, as shown at Fig. 2. To make the bends at the corners of the frame, the horizontal member of the angle-iron is

cut away, as shown in Fig. 3, the vertical member is bent to form an approximate right angle, and the salient angles of the horizontal member are lapped and riveted together. The cut in the horizontal member is defined by two lines which start from a point at the vertical member, diverge at right angles part way through the horizontal member, as shown at 1^b, and then run parallel through the remainder of the horizontal member, as shown at 1^c. When the vertical member is bent, the divergent surfaces 1^b are made to abut one against the other, the salient angles defined by lines 1^c and the edge of the iron are deflected sufficient to overlap, holes, as 1^d, are made through the overlapping portions, and rivets or the like are used to fasten such portions together.

The draft-bars are made of pieces of angle-iron turned with the external angles upward. The intermediate portions of the bars are left unchanged, as shown at 17 in Fig. 11. The front ends are spread slightly, as shown at 17^a in Fig. 10, and the rear ends are compressed, as shown at 17^b in Fig. 12. The spread portion 17^a is provided with rivet-holes in its edges, by means of which it is fastened to a hinge-bracket 18. The compressed portion 17^b is provided with horizontal holes, by means of which it is connected with the disk-frame, and the intermediate portion 17, with its external angle upward presented, constitutes a bar particularly well able to stand the combined stresses to which such bars are subjected.

The tube in the shank portion 10 of disk-frame 9 is open on the side next the disk, and the shank has pins 11 extending from its upper end toward the disk. To keep the tube of the seedbox from rubbing against the disk when it is inserted into the shank of the disk-frame, a plate 12 is fastened at its upper end on pins 11 and riveted at its lower end to a convenient portion of the disk-frame, as shown. This plate forms a wall for the open side of tube 10, separating the seed-tube from the disk and controlling the discharge of the seed.

The scrapers for the disks are each made of a strap or bar of metal, as 13, which extends horizontally across the shank of the disk-frame, then bends on itself, as shown at 14, and extends downward and inward adjacent

to the concaved face of the disk, as shown at 15. The horizontal extension of the scraper-bar has holes that receive the pins 11, and the bar is placed onto the pins and secured there.

5 The furrow-openers are raised and depressed through a transverse rock-shaft 6, suitably journaled in the frame in bearings, as 4 and 5. Arms 7 are mounted on the rock-shaft, and suitable connections, as bars 8, extend
10 between the arms and the furrow-openers. By rocking the shaft 6, so as to raise or lower the arms 7, the furrow-openers are correspondingly elevated or depressed, and one feature of my invention is designed to provide improved means for rocking the shaft 6. To accomplish this, I fix an arm 39 onto the shaft,
15 fasten a bracket 25 onto an extension 24 of the frame, pivot a lever 26 to the bracket, and connect the front end of the lever 26 with arm 39 by means of a link 29. The pivots of these parts are so disposed and the parts are so proportioned that when the furrow-openers are in an intermediate position the conjunction of the link 29 with arm 39 is directly between
25 the center of shaft 6 and the pivot of the link with the lever, and a dead-center lock is formed, as shown in Fig. 6. When this point is passed in either direction, pressure on lever 26 will tend to turn the rock-shaft, forcing it upward if the end of arm 39 is above the
30 dead-lock position, as shown in Fig. 5, and forcing it downward if the end of the arm is below the dead-lock position, as shown in Fig. 7. The weight of the furrow-openers may be
35 depended on to carry the arm downward below the dead-lock; but there is something needed to assist in passing the dead-lock point in upward travel of the arm, and link 29 is extended upward and rearward, as lever 30,
40 in such manner that force applied through the lever will be exerted laterally on the link and the arm 29.

The lever 26 is fulcrumed at 28 on bracket 25, and its lift end 27 is extended forward
45 and downward from the fulcrum. A ratchet-rack 32 is supported concentric with pivot 28, partly by such pivot and partly by a bar 33, which extends forward and connects with the tongue 3 or some other available part of the
50 frame. The lever 26 has a lateral extension that acts as a foot-rest, and it is supplied with a pawl 34 in position to engage the teeth of the ratchet-rack. The pawl has a rearward extension, from the rear end of which
55 projects a toe-bearing 35. A rod 36 is connected pivotally with the pawl in the rear of the pivot thereof and is extended loosely through a lug 37 on lever 26. A spring 38 is placed on rod 36 between the lug and the
60 pawl in a manner to exert pressure toward the pivot of the pawl. The pivot of rod 36 and the bearing of the rod in lug 37 are such that when the pawl is in operative position, as shown in Figs. 5 and 7, the spring will
65 press the detent end of the pawl toward the ratchet-teeth, and when the toe-bearing end of the pawl is depressed to the extent illus-

trated in Fig. 6 the spring acts to hold the pawl out of engagement with the ratchet-teeth. When the operator wants to use the
70 pawl to lock the levers, he raises extension 35 with his toe or otherwise until the pivot of bolt 36 swings past a right line drawn from the pivot of the pawl to the bearing in lug 37, and when he wants the levers to move
75 without restriction from the pawl he depresses the toe extension to a like extent.

The lever 26 is used to depress the furrow-openers and to raise them, pressure being applied downward on the foot-rest in each instance. When the arm and the link are in the relative position shown in Fig. 5, downward pressure on the foot-lever tends to raise the furrow-openers and hold them raised, while when the arm and the link are as shown
85 in Fig. 7 the same downward pressure on the foot-lever will act to depress the furrow-openers. When the position shown in Fig. 6 is reached in upward motion of the furrow-openers, the foot-lever becomes powerless on account of alinement of pivots, and at this juncture the hand-lever 30 is used to carry link 29, which is an extension of the hand-lever, past the dead-center line. In addition to this function of the hand-lever it is obvi-
90 ous that it may be used in conjunction with the foot-lever when the furrow-openers are heavy enough to require special effort to raise them or when there is difficulty in forcing the furrow-openers into the ground the required
95 100 depth.

Another feature of my invention relates to means for supporting the drill-shaft and holding the sprocket-wheel thereon in operative position. Such means consist of a strap, as
105 40, fastened to the front of the seedbox 23 and extended downward and backward under the box, a bar 41, fastened at one end to strap 40 and having a bent extension at the other end that fastens to the seedbox-sup-
110 115 port, and a yoke 42, that is fastened to bar 41. The yoke straddles the sprocket-wheel 45 of the drill-shaft 49, and it provides bearings 43 for the laterally-projecting ends 44 of the hub of the wheel. The bearings support the shaft
120 by supporting the wheel thereon, and the yoke holds the wheel from sidewise motion when the shaft is shifted lengthwise to regulate the discharge of the seed. The sprocket-wheel 45 is driven from sprocket-wheel 21 on shaft
125 20 of carrying-wheels 19 by means of chain 22, and strap 40 is provided with a tightener for the chain. The tightener consists of a slide-block 46, held adjustably on the rear end of strap 40 by means of a set-screw 48 and a
130 bearing-surface 47, extended laterally from the slide-block into the plane of the chain.

What I claim is—

1. A bent frame-bar for planting-machines and the like, comprising an angle-bar one
135 member of which is in the plane of the bend and the other at right angles therewith, the member in the plane of the bend being cut out from the other member part way through

on divergent lines and the remainder of the way through on parallel lines, and the salient portions left by the parallel lines being lapped and fastened together, substantially as set forth.

2. A draft-bar for furrow-openers comprising an angle-bar having its edges disposed in a horizontal plane and its front end spread, substantially set forth.

3. A draft-bar for furrow-openers comprising an angle-bar having its edges disposed in a horizontal plane and its rear end compressed, substantially as set forth.

4. A draft-bar for furrow-openers, comprising an angle-bar having its edges disposed in a horizontal plane, its front end widened and its rear end compressed, substantially as set forth.

5. The combination with a shank having an open side and with a furrow-opening disk journaled on the shank, of a strap fastened horizontally across the open side of the shank and bent downward adjacent to the disk to form a scraper therefor.

6. The combination with a furrow-opening disk, of a frame therefor having a shank-tube with the side next to the disk open, pins projecting from the upper end of the shank toward the disk, a closure-plate hung on the pins of the shank and a scraper-bar fastened on the pins and bent alongside the disk, substantially as set forth.

7. The combination with a furrow-opening disk, of a frame therefor having a shank-tube with the side next the disk open, and a plate fastened to the shank and forming a closure for the open side of the tube thereof.

8. The combination with a rock-shaft adapted to lift and depress the furrow-openers of a planting-machine, of an arm fixed onto the shaft, a lever pivoted to the frame of the planting-machine and a link connecting the force-imparting end of the lever with the arm, the motion of the arm on the rock-shaft being on both sides of a line drawn from the force-imparting end of the lever to the rock-shaft, whereby pressure on the force-receiving end of the lever may rock the shaft in either direction, substantially as set forth.

9. The combination with a rock-shaft adapted to lift and depress the furrow-openers of a planting-machine, of an arm fixed onto the shaft, a foot-lever pivoted to the frame of the planting-machine, a link connecting the end of the lever with the arm, a

rack on the frame and a bolt on the lever to engage the rack, the motion of the arm on the rock-shaft being on both sides of a line from the force-imparting end of the lever to the rock-shaft, substantially as set forth.

10. The combination with the rock-shaft, the arm thereon, the primary lever, and the link connecting such lever with the arm; of a secondary lever adapted to carry the arm past the dead-center point, substantially as set forth.

11. The combination with the rock-shaft, the arm thereon, the primary lever and the link connecting such lever with the arm of the secondary lever forming a continuation of the link substantially as set forth.

12. In lifting mechanism for planters and the like, a lever, a ratchet-rack, a pawl on the lever adapted to engage the rack, and a spring adapted to hold the pawl either into or out of engagement with the rack, substantially as set forth.

13. In a seed-drill, the combination with the drill-shaft of a sprocket-wheel thereon having a sidewise-extended hub and a yoke supported from the drill straddling the sprocket-wheel and forming a bearing for the hub thereof, substantially as set forth.

14. In a seed-drill, the combination with the drill-shaft, of a sprocket-wheel thereon, a strap fastened to the seedbox and extended beneath the same, a horizontal bar fastened at one end to the downward extension of the strap and at the other end to the frame of the box, and a yoke on the bar straddling the sprocket-wheel and forming a bearing for the hub thereof, substantially as set forth.

15. In a seed-drill the combination with the drill-shaft, of a sprocket-wheel thereon, a strap fastened to the seedbox and extended beneath the same, a horizontal bar fastened at one end to the downward extension of the strap and at the other end to the frame of the seedbox, a yoke fastened to the bar, straddling the sprocket-wheel and forming a bearing for the hub of the wheel, and a chain-tightener mounted adjustably on the strap, substantially as set forth.

In testimony whereof I sign my name in the presence of two subscribing witnesses.

GEO. D. HAWORTH.

Witnesses:

G. S. HULL,
MARY E. HAWORTH.