



US008229072B2

(12) **United States Patent**
Balakin

(10) **Patent No.:** **US 8,229,072 B2**
(45) **Date of Patent:** ***Jul. 24, 2012**

(54) **ELONGATED LIFETIME X-RAY METHOD AND APPARATUS USED IN CONJUNCTION WITH A CHARGED PARTICLE CANCER THERAPY SYSTEM**

(76) Inventor: **Vladimir Balakin**, Protvino (RU)

(*) Notice: Subject to any disclaimer, the term of this patent is extended or adjusted under 35 U.S.C. 154(b) by 0 days.

This patent is subject to a terminal disclaimer.

(21) Appl. No.: **13/041,365**

(22) Filed: **Mar. 5, 2011**

(65) **Prior Publication Data**

US 2011/0184221 A1 Jul. 28, 2011

Related U.S. Application Data

(63) Continuation of application No. 12/492,515, filed on Jun. 26, 2009, now Pat. No. 7,940,894.

(60) Provisional application No. 61/055,395, filed on May 22, 2008, provisional application No. 61/137,574, filed on Aug. 1, 2008, provisional application No. 61/192,245, filed on Sep. 17, 2008, provisional application No. 61/055,409, filed on May 22, 2008, provisional application No. 61/203,308, filed on Dec. 22, 2008, provisional application No. 61/188,407, filed on Aug. 11, 2008, provisional application No. 61/209,529, filed on Mar. 9, 2009, provisional application No. 61/188,406, filed on Aug. 11, 2008, provisional application No. 61/189,815, filed on Aug. 25, 2008, provisional application No. 61/208,182, filed on Feb. 23, 2009, provisional application No. 61/201,731, filed on Dec. 15, 2008, provisional application No. 61/208,971, filed on Mar. 3, 2009, provisional application No. 61/205,362, filed on Jan. 12, 2009, provisional application No. 61/134,717, filed on Jul. 14, 2008, provisional application No. 61/134,707, filed on Jul. 14, 2008, provisional

application No. 61/201,732, filed on Dec. 15, 2008, provisional application No. 61/198,509, filed on Nov. 7, 2008, provisional application No. 61/134,718, filed on Jul. 14, 2008, provisional application No. 61/190,613, filed on Sep. 2, 2008, provisional application No. 61/191,043, filed on Sep. 8, 2008, provisional application No. 61/192,237, filed on Sep. 17, 2008, provisional application No. 61/201,728, filed on Dec. 15, 2008, provisional application No. 61/190,546, filed on Sep. 2, 2008, provisional application No. 61/189,017, filed on Aug. 15, 2008, provisional application No. 61/198,248, filed on Nov. 5, 2008, provisional application No. 61/198,508, filed on Nov. 7, 2008, provisional application No. 61/197,971, filed on Nov. 3, 2008, provisional application No. 61/199,405, filed on Nov. 17, 2008, provisional application No. 61/199,403, filed on Nov. 17, 2008, provisional application No. 61/199,404, filed on Nov. 17, 2008.

(51) **Int. Cl.**
A61N 5/10 (2006.01)
(52) **U.S. Cl.** **378/65**; 378/137; 378/138; 250/492.3
(58) **Field of Classification Search** 378/65, 378/121, 137, 138; 250/492.3
See application file for complete search history.

(56) **References Cited**

U.S. PATENT DOCUMENTS
2,306,875 A 12/1942 Fremlin

U.S. PATENT DOCUMENTS
2,790,902 A 4/1957 Wright
3,128,405 A 4/1964 Lambertson
3,412,337 A 11/1968 Lothrop
3,582,650 A * 6/1971 Avery 378/65
3,655,968 A 4/1972 Moore
3,867,705 A 2/1975 Hudson
3,882,339 A 5/1975 Rate
3,906,280 A 9/1975 Andelfinger
4,002,912 A 1/1977 Johnson
4,344,011 A 8/1982 Hayashi
4,607,380 A 8/1986 Oliver
4,622,687 A 11/1986 Whitaker

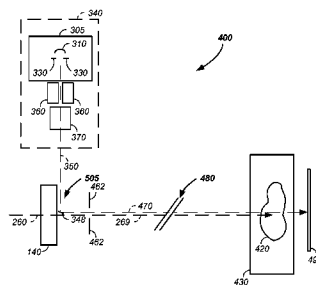
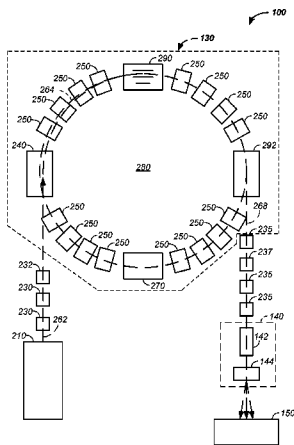

4,726,046 A	2/1988	Nunan	6,736,831 B1	5/2004	Hartmann
4,730,353 A	3/1988	Ono	6,745,072 B1	6/2004	Badura
4,868,844 A	9/1989	Nunan	6,774,383 B2	8/2004	Norimine
4,870,287 A	9/1989	Cole	6,777,700 B2	8/2004	Yanagisawa
4,998,258 A	3/1991	Ikeda	6,785,359 B2	8/2004	Lemaitre
5,017,789 A	5/1991	Young	6,787,771 B2	9/2004	Bashkirov
5,039,867 A	8/1991	Nishihara	6,792,078 B2	9/2004	Kato
5,073,913 A	12/1991	Martin	6,799,068 B1	9/2004	Hartmann
5,168,241 A	12/1992	Hirota	6,800,866 B2	10/2004	Amemiya
5,177,448 A	1/1993	Ikeguchi	6,803,591 B2	10/2004	Muramatsu
5,260,581 A	11/1993	Lesyna	6,809,325 B2	10/2004	Dahl
5,285,166 A	2/1994	Hiramoto	6,819,743 B2	11/2004	Kato
5,349,198 A	9/1994	Takanaka	6,822,244 B2	11/2004	Belousov
5,363,008 A	11/1994	Hiramoto	6,823,045 B2	11/2004	Kato
5,440,133 A	8/1995	Moyers	6,838,676 B1	1/2005	Jackson
5,483,129 A	1/1996	Yamamoto	6,859,741 B2	2/2005	Haberer
5,511,549 A	4/1996	Legg	6,873,123 B2	3/2005	Marchand
5,538,494 A	7/1996	Matsuda	6,881,970 B2	4/2005	Akiyama
5,568,109 A	10/1996	Takayama	6,891,177 B1	5/2005	Kraft
5,576,549 A	11/1996	Hell	6,897,451 B2	5/2005	Kaercher
5,585,642 A	12/1996	Britton	6,900,446 B2	5/2005	Akiyama
5,600,213 A	2/1997	Hiramoto	6,903,351 B1	6/2005	Akiyama
5,626,682 A	5/1997	Kobari	6,903,356 B2	6/2005	Muramatsu
5,633,907 A	5/1997	Gravelle	6,931,100 B2	8/2005	Kato
5,659,223 A	8/1997	Goodman	6,936,832 B2	8/2005	Norimine
5,661,366 A	8/1997	Hirota	6,953,943 B2	10/2005	Yanagisawa
5,668,371 A	9/1997	Deasy	6,979,832 B2	12/2005	Yanagisawa
5,698,954 A	12/1997	Hirota	6,984,835 B2	1/2006	Harada
5,760,395 A	6/1998	Johnstone	6,992,312 B2	1/2006	Yanagisawa
5,789,875 A	8/1998	Hiramoto	6,998,258 B1	2/2006	Kessler
5,818,058 A	10/1998	Nakanishi	7,012,267 B2	3/2006	Moriyama
5,820,320 A	10/1998	Kobari	7,026,636 B2	4/2006	Yanagisawa
5,825,845 A	10/1998	Blair	7,030,396 B2	4/2006	Muramatsu
5,866,912 A	2/1999	Slater	7,045,781 B2	5/2006	Adamec
5,895,926 A	4/1999	Britton	7,049,613 B2	5/2006	Yanagisawa
5,907,595 A	5/1999	Sommerer	7,053,389 B2	5/2006	Yanagisawa
5,917,293 A	6/1999	Saito	7,054,801 B2	5/2006	Sakamoto
5,969,367 A	10/1999	Hiramoto	7,060,997 B2	6/2006	Norimine
5,986,274 A	11/1999	Akiyama	7,071,479 B2	7/2006	Yanagisawa
5,993,373 A	11/1999	Nonaka	7,081,619 B2	7/2006	Bashkirov
6,008,499 A	12/1999	Hiramoto	7,084,410 B2	8/2006	Belousov
6,034,377 A	3/2000	Pu	7,091,478 B2	8/2006	Haberer
6,057,655 A	5/2000	Jongen	7,102,144 B2	9/2006	Matsuda
6,087,670 A	7/2000	Hiramoto	7,109,505 B1	9/2006	Sliski
6,087,672 A	7/2000	Matsuda	7,122,811 B2	10/2006	Matsuda
6,207,952 B1	3/2001	Kan	7,141,810 B2	11/2006	Kakiuchi
6,218,675 B1	4/2001	Akiyama	7,154,107 B2	12/2006	Yanagisawa
6,236,043 B1	5/2001	Tadokoro	7,154,108 B2	12/2006	Tadokoro
6,265,837 B1	7/2001	Akiyama	7,173,264 B2	2/2007	Moriyama
6,282,263 B1	8/2001	Arndt	7,173,265 B2	2/2007	Miller
6,316,776 B1	11/2001	Hiramoto	7,193,227 B2	3/2007	Hiramoto
6,322,249 B1	11/2001	Wofford	7,199,382 B2	4/2007	Rigney
6,335,535 B1	1/2002	Miyake	7,208,748 B2	4/2007	Sliski
6,339,635 B1	1/2002	Schardt	7,212,608 B2	5/2007	Nagamine
6,365,894 B2	4/2002	Tadokoro	7,212,609 B2	5/2007	Nagamine
6,421,416 B1	7/2002	Sliski	7,227,161 B2	6/2007	Matsuda
6,433,336 B1	8/2002	Jongen	7,247,869 B2	7/2007	Tadokoro
6,433,349 B2	8/2002	Akiyama	7,252,745 B2	8/2007	Gorokhovskiy
6,433,494 B1	8/2002	Kulish	7,259,529 B2	8/2007	Tanaka
6,437,513 B1	8/2002	Stelzer	7,262,424 B2	8/2007	Moriyama
6,444,990 B1	9/2002	Morgan	7,274,018 B2	9/2007	Adamec
6,462,490 B1	10/2002	Matsuda	7,274,025 B2	9/2007	Berdermann
6,472,834 B2	10/2002	Hiramoto	7,280,633 B2	10/2007	Cheng
6,476,403 B1	11/2002	Dolinskii	7,297,967 B2	11/2007	Yanagisawa
6,545,436 B1	4/2003	Gary	7,301,162 B2	11/2007	Matsuda
6,560,354 B1	5/2003	Maurer, Jr.	7,307,264 B2	12/2007	Brusco
6,580,084 B1	6/2003	Hiramoto	7,319,231 B2	1/2008	Moriyama
6,597,005 B1	7/2003	Badura	7,345,291 B2	3/2008	Kats
6,600,164 B1	7/2003	Badura	7,345,292 B2	3/2008	Moriyama
6,614,038 B1	9/2003	Brand	7,351,988 B2	4/2008	Naumann
6,617,598 B1	9/2003	Matsuda	7,355,189 B2	4/2008	Yanagisawa
6,635,882 B1	10/2003	Pavlovic	7,356,112 B2	4/2008	Brown
6,639,234 B1	10/2003	Badura	7,368,740 B2	5/2008	Belousov
6,670,618 B1	12/2003	Hartmann	7,372,053 B2	5/2008	Yamashita
6,683,318 B1	1/2004	Haberer	7,381,979 B2	6/2008	Yamashita
6,683,426 B1	1/2004	Kleeven	7,385,203 B2	6/2008	Nakayama
6,710,362 B2	3/2004	Kraft	7,394,082 B2	7/2008	Fujimaki
6,717,162 B1	4/2004	Jongen	7,397,054 B2	7/2008	Natori
6,730,921 B2	5/2004	Kraft	7,397,901 B1	7/2008	Johnsen

7,402,822	B2	7/2008	Guertin	
7,402,823	B2	7/2008	Guertin	
7,402,824	B2	7/2008	Guertin	
7,402,963	B2	7/2008	Sliski	
7,425,717	B2	9/2008	Matsuda	
7,432,516	B2	10/2008	Peggs	
7,439,528	B2	10/2008	Nishiuchi	
7,446,490	B2	11/2008	Jongen	
7,449,701	B2	11/2008	Fujimaki	
7,456,415	B2	11/2008	Yanagisawa	
7,456,591	B2	11/2008	Jongen	
7,465,944	B2	12/2008	Ueno	
7,531,818	B2	5/2009	Brahme	
7,555,103	B2	6/2009	Johnsen	
7,560,717	B2	7/2009	Matsuda	
7,576,342	B2	8/2009	Hiramoto	
7,586,112	B2	9/2009	Chiba	
7,589,334	B2	9/2009	Hiramoto	
7,626,347	B2	12/2009	Sliski	
7,659,521	B2*	2/2010	Pedroni	250/396 R
7,692,168	B2	4/2010	Moriyama	
7,701,677	B2	4/2010	Schultz	
7,709,818	B2	5/2010	Matsuda	
7,718,982	B2	5/2010	Sliski	
7,728,311	B2	6/2010	Gall	
7,755,305	B2	7/2010	Umezawa	
7,772,577	B2	8/2010	Saito	
7,801,277	B2	9/2010	Zou	
7,807,982	B2	10/2010	Nishiuchi	
7,817,778	B2	10/2010	Nord	
7,825,388	B2	11/2010	Nihongi	
7,826,593	B2	11/2010	Svensson	
7,834,336	B2	11/2010	Boeh	
7,838,855	B2	11/2010	Fujii	
7,848,488	B2	12/2010	Mansfield	
7,860,216	B2	12/2010	Jongen	
7,875,868	B2	1/2011	Moriyama	
7,894,574	B1	2/2011	Nord	
7,906,769	B2	3/2011	Blasche	
7,919,765	B2	4/2011	Timmer	
7,940,891	B2	5/2011	Star-Lack	
7,940,894	B2*	5/2011	Balakin	378/138
7,953,205	B2*	5/2011	Balakin	378/69
7,961,844	B2	6/2011	Takeda	
7,977,656	B2	7/2011	Fujimaki	
7,982,198	B2	7/2011	Nishiuchi	
7,987,053	B2	7/2011	Schaffner	
7,995,813	B2	8/2011	Foshee	
8,003,964	B2	8/2011	Stark	
8,009,804	B2	8/2011	Siljamaki	
8,045,679	B2*	10/2011	Balakin	378/65
2003/0163015	A1	8/2003	Yanagisawa	
2003/0164459	A1	9/2003	Schardt	
2004/0022361	A1	2/2004	Lemaitre	
2004/0155206	A1	8/2004	Marchand	
2005/0161618	A1	7/2005	Pedroni	
2005/0211905	A1	9/2005	Stark	
2005/0238134	A1	10/2005	Brusasco	
2005/0269497	A1	12/2005	Jongen	
2006/0106301	A1	5/2006	Kats	
2006/0255285	A1	11/2006	Jongen	
2007/0018121	A1	1/2007	Leyman	
2007/0093723	A1	4/2007	Keall	
2007/0170994	A1	7/2007	Peggs	
2008/0023644	A1	1/2008	Pedroni	
2008/0093567	A1	4/2008	Gall	
2008/0191142	A1*	8/2008	Pedroni	250/396 ML
2009/0096179	A1	4/2009	Stark	
2009/0140672	A1	6/2009	Gall	
2009/0168960	A1	7/2009	Jongen	
2009/0200483	A1	8/2009	Gall	
2009/0236545	A1	9/2009	Timmer	
2009/0283704	A1	11/2009	Nishiuchi	
2009/0289194	A1	11/2009	Saito	
2009/0304153	A1	12/2009	Amelia	
2010/0001212	A1	1/2010	Nishiuchi	
2010/0008468	A1	1/2010	Balakin	
2010/0008469	A1	1/2010	Balakin	
2010/0033115	A1	2/2010	Cleland	

2010/0045213	A1	2/2010	Sliski
2010/0059688	A1	3/2010	Claereboudt
2010/0060209	A1	3/2010	Balakin
2010/0128846	A1	5/2010	Balakin
2010/0230617	A1	9/2010	Gall
2010/0272241	A1	10/2010	Amelia
2010/0308235	A1	12/2010	Sliski
2011/0073778	A1	3/2011	Natori
2011/0089329	A1	4/2011	Jongen
2011/0127443	A1	6/2011	Comer
2011/0137159	A1	6/2011	Jongen
2011/0186720	A1	8/2011	Jongen

FOREIGN PATENT DOCUMENTS

EP	1683545	A2	7/2006
WO	WO 2008/044194	A2	4/2008

OTHER PUBLICATIONS

Adams, "Electrostatic cylinder lenses II: Three Element Einzel Lenses", Journal, Feb. 1, 1972, pp. 150-155, XP002554355, vol. 5 No. 2, Journal of Physics E.

Amaldi, "A Hospital-Based Hadrontherapy Complex", Journal, Jun. 27, 1994, pp. 49-51, XP002552288, Proceedings of Epac 94, London, England.

Arimoto, "A Study of the PRISM-FFAG Magnet", Journal, Oct. 18, 2004, Oct. 22, 2004, pp. 243-245, XP002551810, Proceedings of Cyclotron 2004 Conference, Tokyo, Japan.

Biophysics Group, "Design Construction and First Experiments of a Magnetic Scanning System for Therapy. Radiobiological Experiment on the Radiobiological Action of Carbon, Oxygen and Neon", Book, Jun. 1, 1991, pp. 1-31, XP009121701, vol. GSI-91-18, GSI Report, Darmstadt, DE.

Blackmore, "Operation of the TRIUMF Proton Therapy Facility", Book, May 12, 1997, pp. 3831-3833, XP010322373, vol. 3, Proceedings of the 1997 Particle Accelerator Conference, NJ, USA.

Bryant, "Proton-Ion Medical Machine Study (PIMMS) Part II", Book, Jul. 27, 2000, p. 23, pp. 228, pp. 289-290, XP002551811, European Organisation for Nuclear Research Cern-Ps Division, Geneva, Switzerland.

Craddock, "New Concepts in FFAG Design for Secondary Beam Facilities and other Applications", Journal, May 16, 2005, May 20, 2005, pp. 261-265, XP002551806, Proceedings of 2005 Particle Accelerator Conference, Knoxville, Tennessee, USA.

Dzhelepov, "Use of USSR Proton Accelerators for Medical Purposes", Journal, Jun. 1973, pp. 268-270, vol. ns-2—No. 3, XP002553045, IEEE Transactions on Nuclear Science USA, USA.

Endo, "Medical Synchrotron for Proton Therapy" Journal, Jun. 7, 1988, Jun. 11, 1988, pp. 1459-1461, XP002551808, Proceedings of Epac 88, Rome, Italy.

Johnstone, Koscielniak, "Tune-Stabilized Linear-Field FFAG for Carbon Therapy", Journal, Jun. 26, 2006, Jun. 30, 2006, XP002551807, Proceedings of Epac 2006, Edinburgh, Scotland, UK.

Kalnins, "The use of electric multipole lenses for bending and focusing polar molecules, with application to the design of a rotational-state separator", Journal, May 17, 2003, May 21, 2003, pp. 2951-2953, XP002554356, Proceeding of Pac 2003, Portland, Oregon, USA.

Kim, "50 MeV Proton Beam Test Facility for Low Flux Beam Utilization Studies of PEPF", Journal, Oct. 31, 2005, pp. 441-443, XP002568008, Proceedings of Apac 2004, Pohang, Korea.

Lapostolle, "Introduction a la theorie des accelerateurs lineaires", Book, Jul. 10, 1987, pp. 4-5, XP002554354, Cern Yellow Book Cern, Geneva, Switzerland.

Li, "A thin Beryllium Injection Window for CESR-C", Book, May 12, 2003, pp. 2264-2266, XP002568010, vol. 4, PAC03, Portland, Oregon, USA.

Noda, "Slow beam extraction by a transverse RF field with AM and FM", Journal, May 21, 1996, pp. 269-277, vol. A374, XP002552289, Nuclear Instruments and Methods in Physics Research A, Eslevier, Amsterdam, NL.

Noda, "Performance of a respiration-gated beam control system for patient treatment", Journal, Jun. 10, 1996, Jun. 14, 1996, pp. 2656-2658, XP002552290, Proceedings Epac 96, Barcelona, Spain.

Peters, "Negative ion sources for high energy accelerators", Journal, Feb. 1, 2000, pp. 1069-1074, XP012037926, vol. 71—No. 2, Review of Scientific Instruments, Melville, NY, USA.

Pohlit, "Optimization of Cancer Treatment with Accelerator Produced Radiations", Journal, Jun. 22, 1998, pp. 192-194, XP002552855, Proceedings EPAC 98, Stockholm, Sweden.

Saito, "RF Accelerating System for Compact Ion Synchrotron", Journal, Jun. 18, 2001, pp. 966-968, XP002568009, Proceeding of 2001 Pac, Chicago, USA.

Suda, "Medical Application of the Positron Emitter Beam at HIMAC", Journal, Jun. 26, 2000, Jun. 30, 2000, pp. 2554-2556, XP002553046, Proceedings of EPAC 2000, Vienna, Austria.

Tanigaki, "Construction of FFAG Accelerators in KURRI for ADS Study", May 16, 2005, May 20, 2005, pp. 350-352, XP002551809, Proceedings of 2005 Particle Accelerator Conference, Knoxville, Tennessee, USA.

Trbojevic, "Design of a Non-Scaling FFAG Accelerator for Proton Therapy", Journal, Oct. 18, 2004, Oct. 22, 2004, pp. 246-248, XP002551805, Proceedings of 2004 Cyclotron Conference, Tokyo, Japan.

Winkler, "Charge Exchange Extraction at the Experimental Storage Ring ESR at GSI", Journal, Jun. 22, 1998, p. 559-561, XP002552287, Proceedings of Epac 98, Stockholm, Sweden.

* cited by examiner

Primary Examiner — Thomas R Artman

(74) *Attorney, Agent, or Firm* — Kevin Hazen

(57)

ABSTRACT

The system uses an X-ray imaging system having an elongated lifetime. Further, the system uses an X-ray beam that lies in substantially the same path as a charged particle beam path of a particle beam cancer therapy system. The system creates an electron beam that strikes an X-ray generation source located proximate to the charged particle beam path. By generating the X-rays near the charged particle beam path, an X-ray path running collinear, in parallel with, and/or substantially in contact with the charged particle beam path is created. The system then collects X-ray images of localized body tissue region about a cancerous tumor. Since, the X-ray path is essentially the charged particle beam path, the generated image is usable for precisely target the tumor with a charged particle beam.

21 Claims, 6 Drawing Sheets

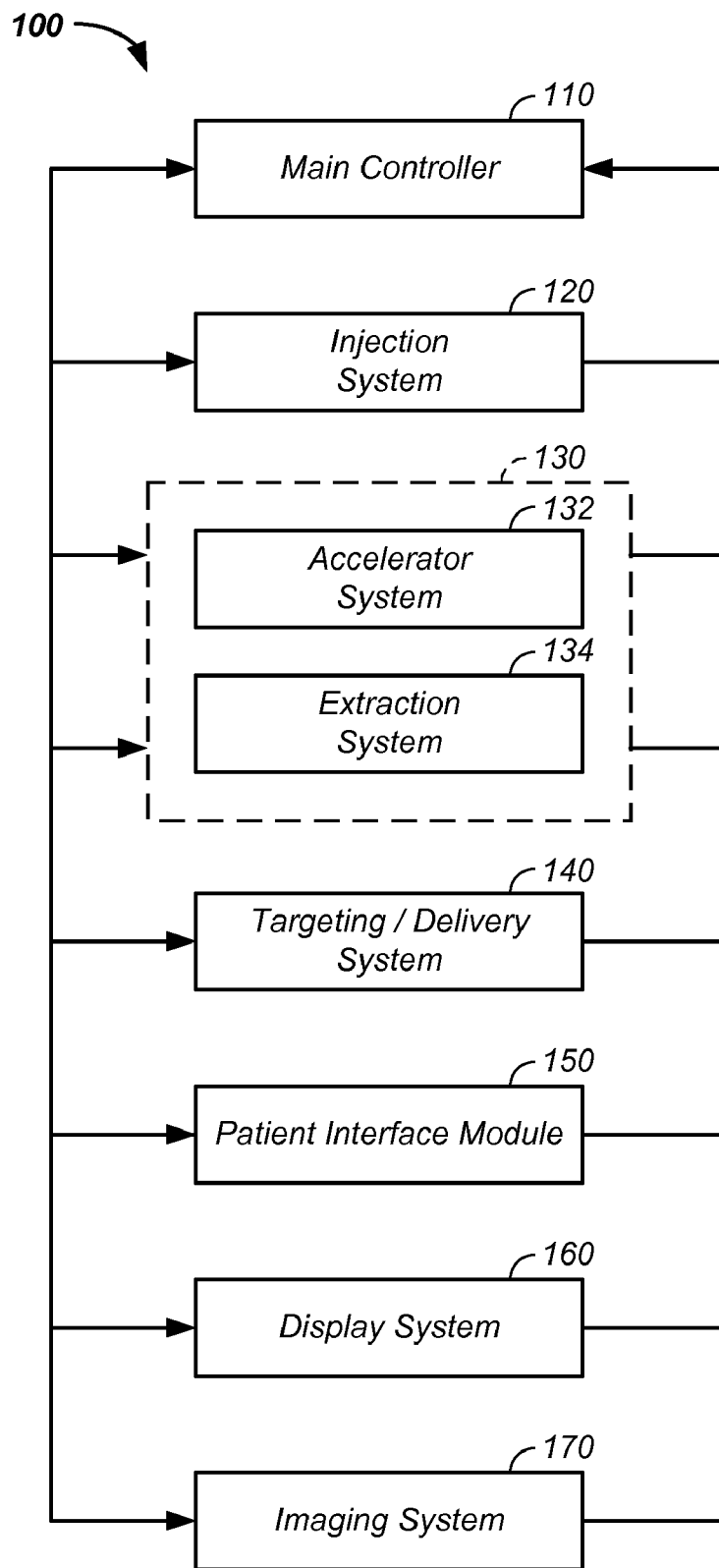

FIG. 1

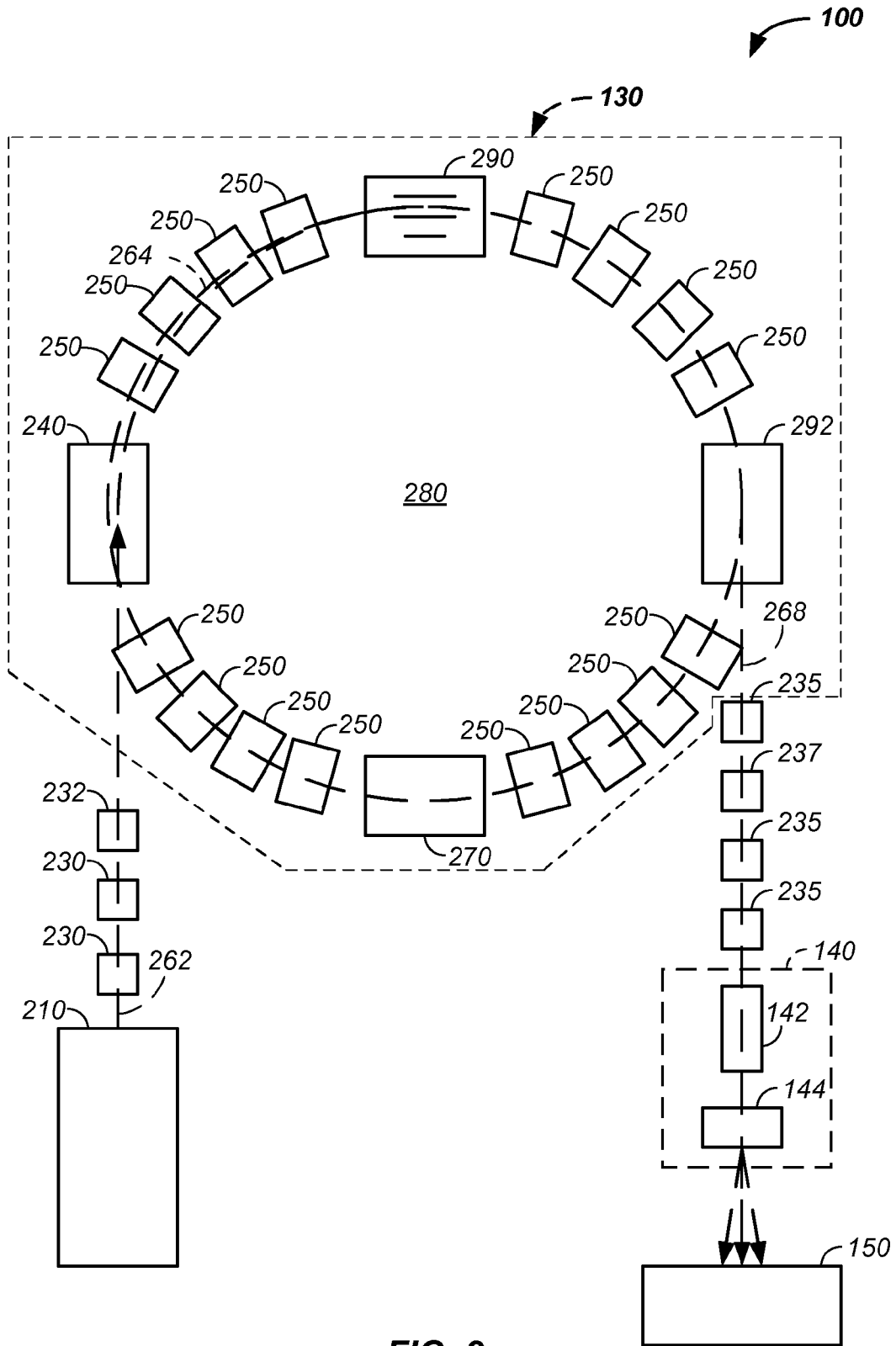

FIG. 2

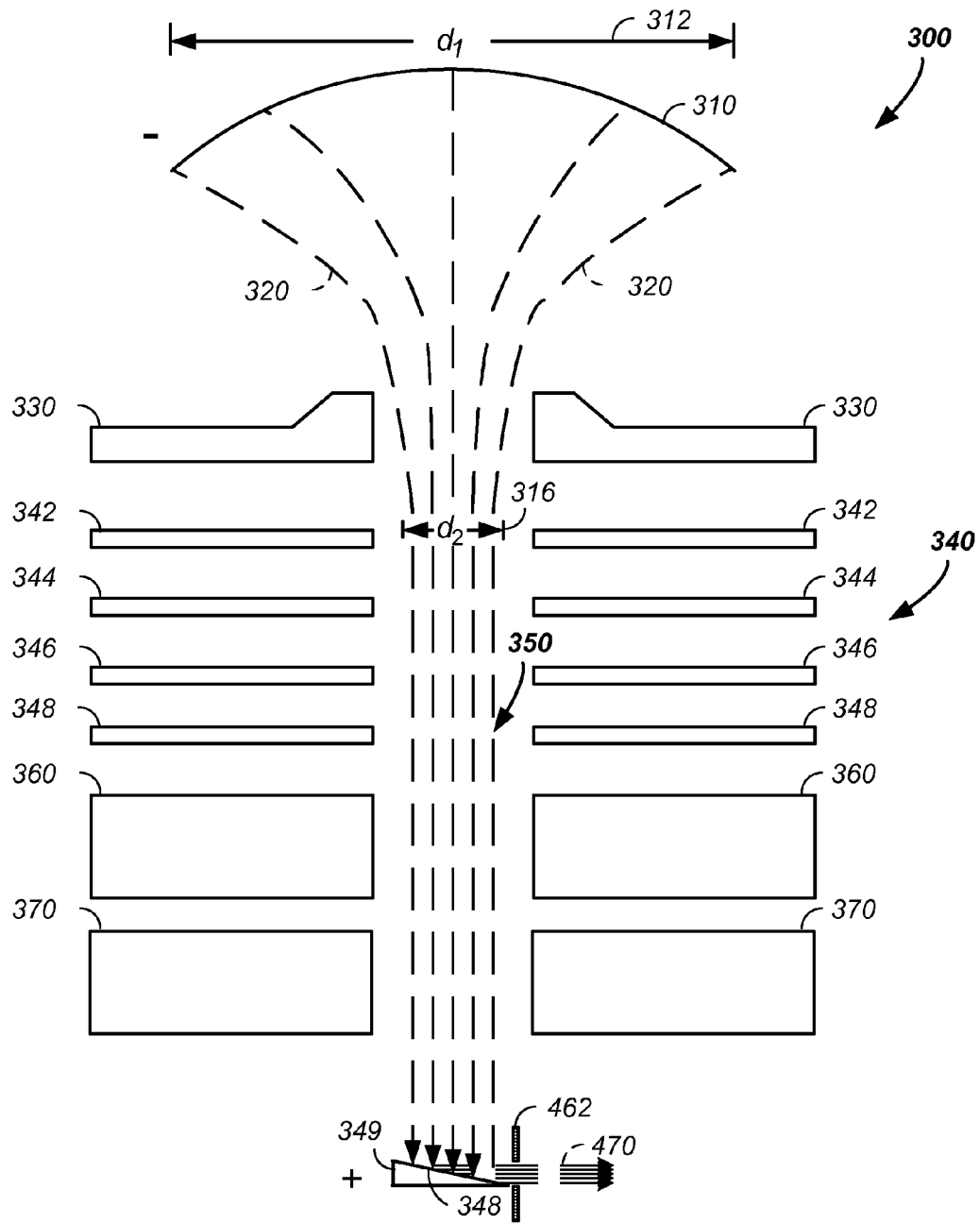

FIG. 3

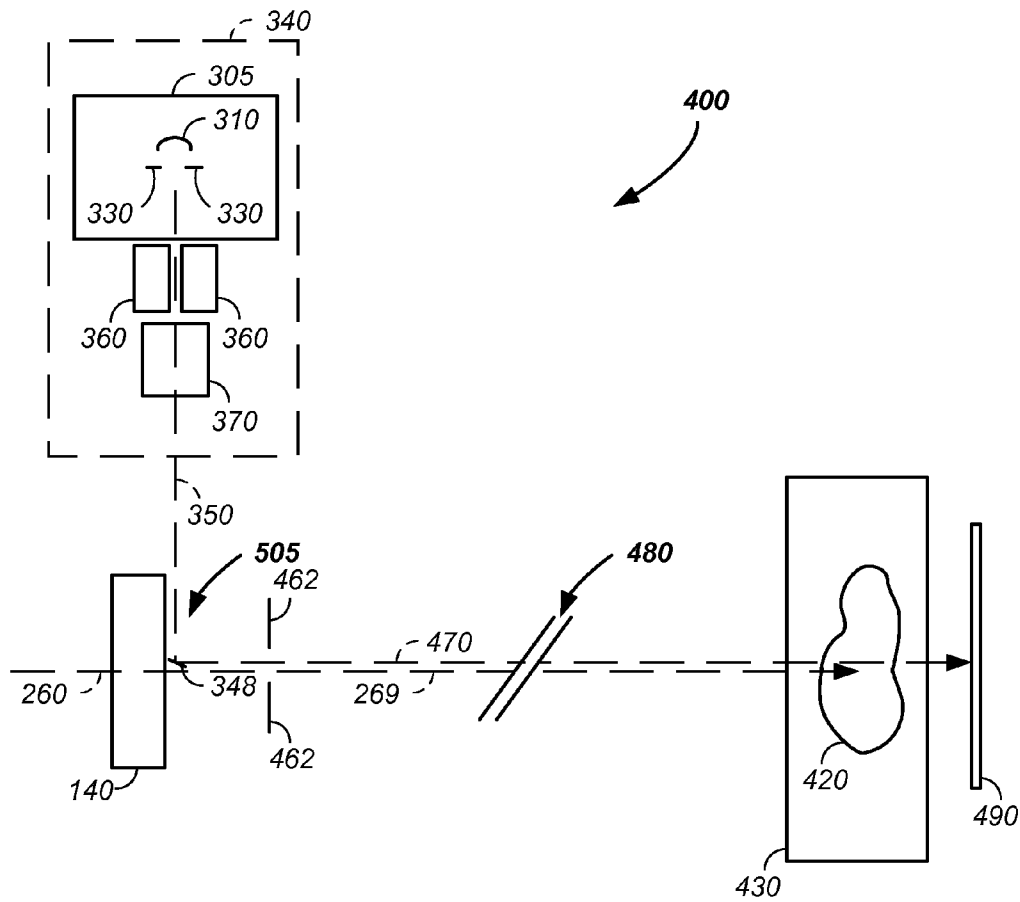

FIG. 4

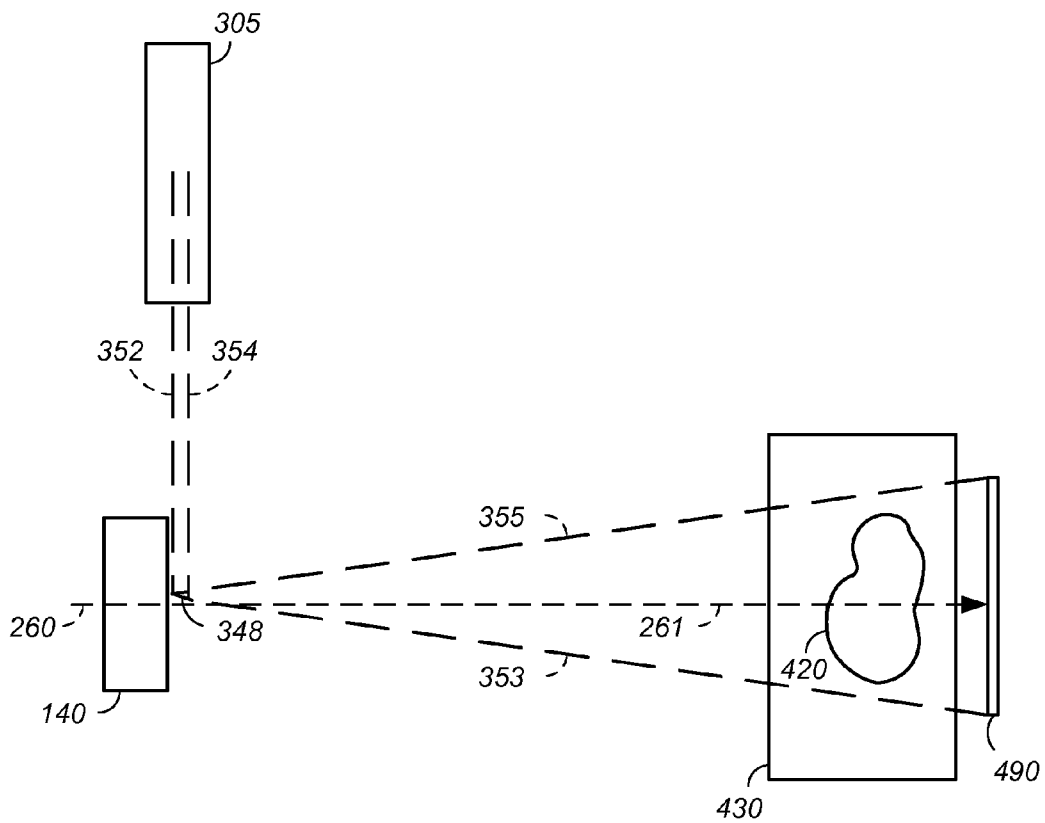

FIG. 5

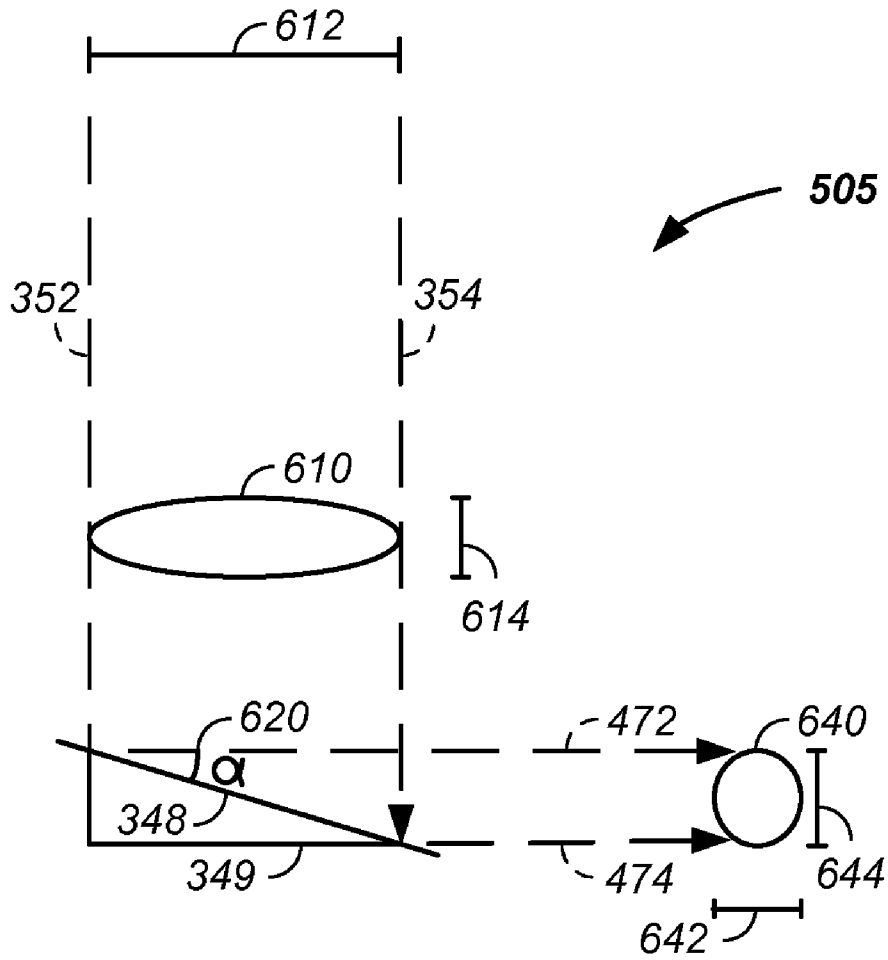

FIG. 6

1

**ELONGATED LIFETIME X-RAY METHOD
AND APPARATUS USED IN CONJUNCTION
WITH A CHARGED PARTICLE CANCER
THERAPY SYSTEM**

CROSS REFERENCES TO RELATED
APPLICATIONS

This application is a continuation of U.S. patent applica-
tion Ser. No. 12/492,515 filed Jun. 26, 2009, now U.S. Pat No
7,940,894 which claims benefit of:

U.S. provisional patent application No. 61/055,395 filed
May 22, 2008;

U.S. provisional patent application No. 61/137,574 filed
Aug. 1, 2008;

U.S. provisional patent application No. 61/192,245 filed
Sep. 17, 2008;

U.S. provisional patent application No. 61/055,409 filed
May 22, 2008;

U.S. provisional patent application No. 61/203,308 filed
Dec. 22, 2008;

U.S. provisional patent application No. 61/188,407 filed
Aug. 11, 2008;

U.S. provisional patent application No. 61/209,529 filed
Mar. 9, 2009;

U.S. provisional patent application No. 61/188,406 filed
Aug. 11, 2008;

U.S. provisional patent application No. 61/189,815 filed
Aug. 25, 2008;

U.S. provisional patent application No. 61/208,182 filed
Feb. 23, 2009;

U.S. provisional patent application No. 61/201,731 filed
Dec. 15, 2008;

U.S. provisional patent application No. 61/208,971 filed
Mar. 3, 2009;

U.S. provisional patent application No. 61/205,362 filed
Jan. 12, 2009;

U.S. provisional patent application No. 61/134,717 filed
Jul. 14, 2008;

U.S. provisional patent application No. 61/134,707 filed
Jul. 14, 2008;

U.S. provisional patent application No. 61/201,732 filed
Dec. 15, 2008;

U.S. provisional patent application No. 61/198,509 filed
Nov. 7, 2008;

U.S. provisional patent application No. 61/134,718 filed
Jul. 14, 2008;

U.S. provisional patent application No. 61/190,613 filed
Sep. 2, 2008;

U.S. provisional patent application No. 61/191,043 filed
Sep. 8, 2008;

U.S. provisional patent application No. 61/192,237 filed
Sep. 17, 2008;

U.S. provisional patent application No. 61/201,728 filed
Dec. 15, 2008;

U.S. provisional patent application No. 61/190,546 filed
Sep. 2, 2008;

U.S. provisional patent application No. 61/189,017 filed
Aug. 15, 2008;

U.S. provisional patent application No. 61/198,248 filed
Nov. 5, 2008;

U.S. provisional patent application No. 61/198,508 filed
Nov. 7, 2008;

U.S. provisional patent application No. 61/197,971 filed
Nov. 3, 2008;

U.S. provisional patent application No. 61/199,405 filed
Nov. 17, 2008;

2

U.S. provisional patent application No. 61/199,403 filed
Nov. 17, 2008; and

U.S. provisional patent application No. 61/199,404 filed
Nov. 17, 2008,

5 all of which are incorporated herein in their entirety by this
reference thereto.

BACKGROUND OF THE INVENTION

1. Field of the Invention

This invention relates generally to treatment of solid can-
cers. More particularly, the invention relates to an elongated
lifetime X-ray method and apparatus used in conjunction
with radiation treatment of cancerous tumors.

2. Discussion of the Prior Art

Cancer

A tumor is an abnormal mass of tissue. Tumors are either
benign or malignant. A benign tumor grows locally, but does
not spread to other parts of the body. Benign tumors cause
problems because of their spread, as they press and displace
normal tissues. Benign tumors are dangerous in confined
places such as the skull. A malignant tumor is capable of
invading other regions of the body. Metastasis is cancer
spreading by invading normal tissue and spreading to distant
tissues.

Cancer Treatment

Several forms of radiation therapy exist for cancer treat-
ment including: brachytherapy, traditional electromagnetic
X-ray therapy, and proton therapy. Each are further described,
infra.

Brachytherapy is radiation therapy using radioactive
sources implanted inside the body. In this treatment, an
oncologist implants radioactive material directly into the
tumor or very close to it. Radioactive sources are also placed
within body cavities, such as the uterine cervix.

The second form of traditional cancer treatment using elec-
tromagnetic radiation includes treatment using X-rays and
gamma rays. An X-ray is high-energy, ionizing, electromag-
netic radiation that is used at low doses to diagnose disease or
at high doses to treat cancer. An X-ray or Röntgen ray is a
form of electromagnetic radiation with a wavelength in the
range of 10 to 0.01 nanometers (nm), corresponding to fre-
quencies in the range of 30 PHz to 30 EHz. X-rays are longer
than gamma rays and shorter than ultraviolet rays. X-rays are
primarily used for diagnostic radiography. X-rays are a form
of ionizing radiation and as such can be dangerous. Gamma
rays are also a form of electromagnetic radiation and are at
frequencies produced by sub-atomic particle interactions,
such as electron-positron annihilation or radioactive decay. In
the electromagnetic spectrum, gamma rays are generally
characterized as electromagnetic radiation having the highest
frequency, as having highest energy, and having the shortest
wavelength, such as below about 10 picometers. Gamma rays
consist of high energy photons with energies above about 100
keV. X-rays are commonly used to treat cancerous tumors.
However, X-rays are not optimal for treatment of cancerous
tissue as X-rays deposit their highest doses of radiation near
the surface of the targeted tissue and delivery exponentially
less radiation as they penetrate into the tissue. This results in
large amounts of radiation being delivered outside of the
tumor. Gamma rays have similar limitations.

The third form of cancer treatment uses protons. Proton
therapy systems typically include: a beam generator, an accel-
erator, and a beam transport system to move the resulting
accelerated protons to a plurality of treatment rooms where
the protons are delivered to a tumor in a patient's body.

Proton therapy works by aiming energetic ionizing particles, such as protons accelerated with a particle accelerator, onto a target tumor. These particles damage the DNA of cells, ultimately causing their death. Cancerous cells, because of their high rate of division and their reduced ability to repair damaged DNA, are particularly vulnerable to attack on their DNA.

Due to their relatively enormous size, protons scatter less easily in the tissue and there is very little lateral dispersion. Hence, the proton beam stays focused on the tumor shape without much lateral damage to surrounding tissue. All protons of a given energy have a certain range, defined by the Bragg peak, and the dosage delivery to tissue ratio is maximum over just the last few millimeters of the particle's range. The penetration depth depends on the energy of the particles, which is directly related to the speed to which the particles were accelerated by the proton accelerator. The speed of the proton is adjustable to the maximum rating of the accelerator. It is therefore possible to focus the cell damage due to the proton beam at the very depth in the tissues where the tumor is situated. Tissues situated before the Bragg peak receive some reduced dose and tissues situated after the peak receive none.

Synchrotrons

Patents related to the current invention are summarized here.

Proton Beam Therapy System

F. Cole, et. al. of Loma Linda University Medical Center "Multi-Station Proton Beam Therapy System", U.S. Pat. No. 4,870,287 (Sep. 26, 1989) describe a proton beam therapy system for selectively generating and transporting proton beams from a single proton source and accelerator to a selected treatment room of a plurality of patient treatment rooms.

Transport/Scanning Control

K. Matsuda, et. al. "Particle Beam Irradiation Apparatus, Treatment Planning Unit, and Particle Beam Irradiation Method", U.S. Pat. No. 7,227,161 (Jun. 5, 2007); K. Matsuda, et. al. "Particle Beam Irradiation Treatment Planning Unit, and Particle Beam Irradiation Method", U.S. Pat. No. 7,122,811 (Oct. 17, 2006); and K. Matsuda, et. al. "Particle Beam Irradiation Apparatus, Treatment Planning Unit, and Particle Beam Irradiation Method" (Sep. 5, 2006) describe a particle beam irradiation apparatus have a scanning controller that stops output of an ion beam, changes irradiation position via control of scanning electromagnets, and reinitiates treatment based on treatment planning information.

T. Norimine, et. al. "Particle Therapy System Apparatus", U.S. patent numbers: U.S. Pat. No. 7,060,997 (Jun. 13, 2006); T. Norimine, et. al. "Particle Therapy System Apparatus", U.S. Pat. No. 6,936,832 (Aug. 30, 2005); and T. Norimine, et. al. "Particle Therapy System Apparatus", U.S. Pat. No. 6,774,383 (Aug. 10, 2004) each describe a particle therapy system having a first steering magnet and a second steering magnet disposed in a charged particle beam path after a synchrotron that are controlled by first and second beam position monitors.

K. Moriyama, et. al. "Particle Beam Therapy System", U.S. Pat. No. 7,012,267 (Mar. 14, 2006) describe a manual input to a ready signal indicating preparations are completed for transport of the ion beam to a patient.

H. Harada, et. al. "Irradiation Apparatus and Irradiation Method", U.S. Pat. No. 6,984,835 (Jan. 10, 2006) describe an irradiation method having a large irradiation field capable of uniform dose distribution, without strengthening performance of an irradiation field device, using a position controller having overlapping area formed by a plurality of irradiations

using a multileaf collimator. The system provides flat and uniform dose distribution over an entire surface of a target.

H. Akiyama, et. al. "Charged Particle Beam Irradiation Equipment Having Scanning Electromagnet Power Supplies", U.S. Pat. No. 6,903,351 (Jun. 7, 2005); H. Akiyama, et. al. "Charged Particle Beam Irradiation Equipment Having Scanning Electromagnet Power Supplies", U.S. Pat. No. 6,900,436 (May 31, 2005); and H. Akiyama, et. al. "Charged Particle Beam Irradiation Equipment Having Scanning Electromagnet Power Supplies", U.S. Pat. No. 6,881,970 (Apr. 19, 2005) all describe a power supply for applying a voltage to a scanning electromagnet for deflecting a charged particle beam and a second power supply without a pulsating component to control the scanning electromagnet more precisely allowing for uniform irradiation of the irradiation object.

K. Amemiya, et. al. "Accelerator System and Medical Accelerator Facility", U.S. Pat. No. 6,800,866 (Oct. 5, 2004) describe an accelerator system having a wide ion beam control current range capable of operating with low power consumption and having a long maintenance interval.

A. Dolinskii, et. al. "Gantry with an Ion-Optical System", U.S. Pat. No. 6,476,403 (Nov. 5, 2002) describe a gantry for an ion-optical system comprising an ion source and three bending magnets for deflecting an ion beam about an axis of rotation. A plurality of quadrupoles are also provided along the beam path to create a fully achromatic beam transport and an ion beam with difference emittances in the horizontal and vertical planes. Further, two scanning magnets are provided between the second and third bending magnets to direct the beam.

H. Akiyama, et. al. "Charged Particle Beam Irradiation Apparatus", U.S. Pat. No. 6,218,675 (Apr. 17, 2001) describe a charged particle beam irradiation apparatus for irradiating a target with a charged particle beam that include a plurality of scanning electromagnets and a quadrupole electromagnet between two of the plurality of scanning electromagnets.

K. Matsuda, et. al. "Charged Particle Beam Irradiation System and Method Thereof", U.S. Pat. No. 6,087,672 (Jul. 11, 2000) describe a charged particle beam irradiation system having a ridge filter with shielding elements to shield a part of the charged particle beam in an area corresponding to a thin region in said target.

P. Young, et. al. "Raster Scan Control System for a Charged-Particle Beam", U.S. Pat. No. 5,017,789 (May 21, 1991) describe a raster scan control system for use with a charged-particle beam delivery system that includes a nozzle through which a charged particle beam passes. The nozzle includes a programmable raster generator and both fast and slow sweep scan electromagnets that cooperate to generate a sweeping magnetic field that steers the beam along a desired raster scan pattern at a target.

Beam Shape Control

M. Yanagisawa, et. al. "Particle Beam Irradiation System and Method of Adjusting Irradiation Field Forming Apparatus", U.S. Pat. No. 7,154,107 (Dec. 26, 2006) and M. Yanagisawa, et. al. "Particle Beam Irradiation System and Method of Adjusting Irradiation Field Forming Apparatus", U.S. Pat. No. 7,049,613 (May 23, 2006) describe a particle therapy system having a scattering compensator and a range modulation wheel. Movement of the scattering compensator and the range modulation wheel adjusts a size of the ion beam and scattering intensity resulting in penumbra control and a more uniform dose distribution to a diseased body part.

T. Haberer, et. al. "Device and Method for Adapting the Size of an Ion Beam Spot in the Domain of Tumor Irradiation", U.S. Pat. No. 6,859,741 (Feb. 22, 2005) describe a

method and apparatus for adapting the size of an ion beam in tumor irradiation. Quadrupole magnets determining the size of the ion beam spot are arranged directly in front of raster scanning magnets determining the size of the ion beam spot. The apparatus contains a control loop for obtaining current correction values to further control the ion beam spot size.

K. Matsuda, et. al. "Charged Particle Irradiation Apparatus and an Operating Method Thereof", U.S. Pat. No. 5,986,274 (Nov. 16, 1999) describe a charged particle irradiation apparatus capable of decreasing a lateral dose falloff at boundaries of an irradiation field of a charged particle beam using controlling magnet fields of quadrupole electromagnets and deflection electromagnets to control the center of the charged particle beam passing through the center of a scatterer irrespective of direction and intensity of a magnetic field generated by scanning electromagnets.

K. Hiramoto, et. al. "Charged Particle Beam Apparatus and Method for Operating the Same", U.S. Pat. No. 5,969,367 (Oct. 19, 1999) describe a charged particle beam apparatus where a the charged particle beam is enlarged by a scatterer resulting in a Gaussian distribution that allows overlapping of irradiation doses applied to varying spot positions.

M. Moyers, et. al. "Charged Particle Beam Scattering System", U.S. Pat. No. 5,440,133 (Aug. 8, 1995) describe a radiation treatment apparatus for producing a particle beam and a scattering foil for changing the diameter of the charged particle beam.

C. Nunan "Multileaf Collimator for Radiotherapy Machines", U.S. Pat. No. 4,868,844 (Sep. 19, 1989) describes a radiation therapy machine having a multileaf collimator formed of a plurality of heavy metal leaf bars movable to form a rectangular irradiation field.

R. Maughan, et. al. "Variable Radiation Collimator", U.S. Pat. No. 4,754,147 (Jun. 28, 1988) describe a variable collimator for shaping a cross-section of a radiation beam that relies on rods, which are positioned around a beam axis. The rods are shaped by a shaping member cut to a shape of an area of a patient go be irradiated.

Beam Energy/Intensity

M. Yanagisawa, et. al. "Charged Particle Therapy System, Range Modulation Wheel Device, and Method of Installing Range Modulation Wheel Device", U.S. Pat. No. 7,355,189 (Apr. 8, 2008) and Yanagisawa, et. al. "Charged Particle Therapy System, Range Modulation Wheel Device, and Method of Installing Range Modulation Wheel Device", U.S. Pat. No. 7,053,389 (May 30, 2008) both describe a particle therapy system having a range modulation wheel. The ion beam passes through the range modulation wheel resulting in a plurality of energy levels corresponding to a plurality of stepped thicknesses of the range modulation wheel.

M. Yanagisawa, et. al. "Particle Beam Irradiation System and Method of Adjusting Irradiation Apparatus", U.S. Pat. No. 7,297,967 (Nov. 20, 2007); M. Yanagisawa, et. al. "Particle Beam Irradiation System and Method of Adjusting Irradiation Apparatus", U.S. Pat. No. 7,071,479 (Jul. 4, 2006); M. Yanagisawa, et. al. "Particle Beam Irradiation System and Method of Adjusting Irradiation Apparatus", U.S. Pat. No. 7,026,636 (Apr. 11, 2006); and M. Yanagisawa, et. al. "Particle Beam Irradiation System and Method of Adjusting Irradiation Apparatus", U.S. Pat. No. 6,777,700 (Aug. 17, 2004) all describe a scattering device, a range adjustment device, and a peak spreading device. The scattering device and range adjustment device are combined together and are moved along a beam axis. The spreading device is independently moved along the axis to adjust the degree of ion beam scattering. Combined, the devise increases the degree of uniformity of radiation dose distribution to a diseased tissue.

A. Sliski, et. al. "Programmable Particle Scatterer for Radiation Therapy Beam Formation", U.S. Pat. No. 7,208,748 (Apr. 24, 2007) describe a programmable pathlength of a fluid disposed into a particle beam to modulate scattering angle and beam range in a predetermined manner. The charged particle beam scatterer/range modulator comprises a fluid reservoir having opposing walls in a particle beam path and a drive to adjust the distance between the walls of the fluid reservoir under control of a programmable controller to create a predetermined spread out Bragg peak at a predetermined depth in a tissue. The beam scattering and modulation is continuously and dynamically adjusted during treatment of a tumor to deposit a dose in a targeted predetermined three dimensional volume.

M. Tadokoro, et. al. "Particle Therapy System", U.S. Pat. No. 7,247,869 (Jul. 24, 2007) and U.S. Pat. No. 7,154,108 (Dec. 26, 2006) each describe a particle therapy system capable of measuring energy of a charged particle beam during irradiation during use. The system includes a beam passage between a pair of collimators, an energy detector mounted, and a signal processing unit.

G. Kraft, et. al. "Ion Beam Scanner System and Operating Method", U.S. Pat. No. 6,891,177 (May 10, 2005) describe an ion beam scanning system having a mechanical alignment system for the target volume to be scanned and allowing for depth modulation of the ion beam by means of a linear motor and transverse displacement of energy absorption means resulting in depth-staggered scanning of volume elements of a target volume.

G. Hartmann, et. al. "Method for Operating an Ion Beam Therapy System by Monitoring the Distribution of the Radiation Dose", U.S. Pat. No. 6,736,831 (May 18, 2004) describe a method for operation of an ion beam therapy system having a grid scanner and irradiates and scans an area surrounding an isocentre. Both the depth dose distribution and the transverse dose distribution of the grid scanner device at various positions in the region of the isocentre are measured and evaluated.

Y. Jongen "Method for Treating a Target Volume with a Particle Beam and Device Implementing Same", U.S. Pat. No. 6,717,162 (Apr. 6, 2004) describes a method of producing from a particle beam a narrow spot directed towards a target volume, characterized in that the spot sweeping speed and particle beam intensity are simultaneously varied.

G. Kraft, et. al. "Device for Irradiating a Tumor Tissue", U.S. Pat. No. 6,710,362 (Mar. 23, 2004) describe a method and apparatus of irradiating a tumor tissue, where the apparatus has an electromagnetically driven ion-braking device in the proton beam path for depth-wise adaptation of the proton beam that adjusts both the ion beam direction and ion beam range.

K. Matsuda, et. al. "Charged Particle Beam Irradiation Apparatus", U.S. Pat. No. 6,617,598 (Sep. 9, 2003) describe a charged particle beam irradiation apparatus that increased the width in a depth direction of a Bragg peak by passing the Bragg peak through an enlarging device containing three ion beam components having different energies produced according to the difference between passed positions of each of the filter elements.

H. Stelzer, et. al. "Ionization Chamber for Ion Beams and Method for Monitoring the Intensity of an Ion Beam", U.S. Pat. No. 6,437,513 (Aug. 20, 2002) describe an ionization chamber for ion beams and a method of monitoring the intensity of an ion therapy beam. The ionization chamber includes a chamber housing, a beam inlet window, a beam outlet window, a beam outlet window, and a chamber volume filled with counting gas.

H. Akiyama, et. al. "Charged-Particle Beam Irradiation Method and System", U.S. Pat. No. 6,433,349 (Aug. 13, 2002) and H. Akiyama, et. al. "Charged-Particle Beam Irradiation Method and System", U.S. Pat. No. 6,265,837 (Jul. 24, 2001) both describe a charged particle beam irradiation system that includes a changer for changing energy of the particle and an intensity controller for controlling an intensity of the charged-particle beam.

Y. Pu "Charged Particle Beam Irradiation Apparatus and Method of Irradiation with Charged Particle Beam", U.S. Pat. No. 6,034,377 (Mar. 7, 2000) describes a charged particle beam irradiation apparatus having an energy degrader comprising: (1) a cylindrical member having a length; and (2) a distribution of wall thickness in a circumferential direction around an axis of rotation, where thickness of the wall determines energy degradation of the irradiation beam.

Dosage

K. Matsuda, et. al. "Particle Beam Irradiation System", U.S. Pat. No. 7,372,053 (Nov. 27, 2007) describe a particle beam irradiation system ensuring a more uniform dose distribution at an irradiation object through use of a stop signal, which stops the output of the ion beam from the irradiation device.

H. Sakamoto, et. al. "Radiation Treatment Plan Making System and Method", U.S. Pat. No. 7,054,801 (May 30, 2006) describe a radiation exposure system that divides an exposure region into a plurality of exposure regions and uses a radiation simulation to plan radiation treatment conditions to obtain flat radiation exposure to the desired region.

G. Hartmann, et. al. "Method For Verifying the Calculated Radiation Dose of an Ion Beam Therapy System", U.S. Pat. No. 6,799,068 (Sep. 28, 2004) describe a method for the verification of the calculated dose of an ion beam therapy system that comprises a phantom and a discrepancy between the calculated radiation dose and the phantom.

H. Brand, et. al. "Method for Monitoring the Irradiation Control of an Ion Beam Therapy System", U.S. Pat. No. 6,614,038 (Sep. 2, 2003) describe a method of checking a calculated irradiation control unit of an ion beam therapy system, where scan data sets, control computer parameters, measuring sensor parameters, and desired current values of scanner magnets are permanently stored.

T. Kan, et. al. "Water Phantom Type Dose Distribution Determining Apparatus", U.S. Pat. No. 6,207,952 (Mar. 27, 2001) describe a water phantom type dose distribution apparatus that includes a closed water tank, filled with water to the brim, having an inserted sensor that is used to determine an actual dose distribution of radiation prior to radiation therapy. Starting/Stopping Irradiation

K. Hiramoto, et. al. "Charged Particle Beam Apparatus and Method for Operating the Same", U.S. Pat. No. 6,316,776 (Nov. 13, 2001) describe a charged particle beam apparatus where a charged particle beam is positioned, started, stopped, and repositioned repetitively. Residual particles are used in the accelerator without supplying new particles if sufficient charge is available.

K. Matsuda, et. al. "Method and Apparatus for Controlling Circular Accelerator", U.S. Pat. No. 6,462,490 (Oct. 8, 2002) describe a control method and apparatus for a circular accelerator for adjusting timing of emitted charged particles. The clock pulse is suspended after delivery of a charged particle stream and is resumed on the basis of state of an object to be irradiated.

Movable Patient

N. Rigney, et. al. "Patient Alignment System with External Measurement and Object Coordination for Radiation Therapy System", U.S. Pat. No. 7,199,382 (Apr. 3, 2007)

describe a patient alignment system for a radiation therapy system that includes multiple external measurement devices that obtain position measurements of movable components of the radiation therapy system. The alignment system uses the external measurements to provide corrective positioning feedback to more precisely register the patient to the radiation beam.

Y. Muramatsu, et. al. "Medical Particle Irradiation Apparatus", U.S. Pat. No. 7,030,396 (Apr. 18, 2006); Y. Muramatsu, et. al. "Medical Particle Irradiation Apparatus", U.S. Pat. No. 6,903,356 (Jun. 7, 2005); and Y. Muramatsu, et. al.

"Medical Particle Irradiation Apparatus", U.S. Pat. No. 6,803,591 (Oct. 12, 2004) all describe a medical particle irradiation apparatus having a rotating gantry, an annular frame located within the gantry such that it can rotate relative to the rotating gantry, an anti-correlation mechanism to keep the frame from rotating with the gantry, and a flexible moving floor engaged with the frame in such a manner to move freely with a substantially level bottom while the gantry rotates.

H. Nonaka, et. al. "Rotating Radiation Chamber for Radiation Therapy", U.S. Pat. No. 5,993,373 (Nov. 30, 1999) describe a horizontal movable floor composed of a series of multiple plates that are connected in a free and flexible manner, where the movable floor is moved in synchrony with rotation of a radiation beam irradiation section.

Respiration

K. Matsuda "Radioactive Beam Irradiation Method and Apparatus Taking Movement of the Irradiation Area Into Consideration", U.S. Pat. No. 5,538,494 (Jul. 23, 1996) describes a method and apparatus that enables irradiation even in the case of a diseased part changing position due to physical activity, such as breathing and heart beat. Initially, a position change of a diseased body part and physical activity of the patient are measured concurrently and a relationship therebetween is defined as a function. Radiation therapy is performed in accordance to the function.

Patient Positioning

Y. Nagamine, et. al. "Patient Positioning Device and Patient Positioning Method", U.S. Pat. Nos. 7,212,609 and 7,212,608 (May 1, 2007) describe a patient positioning system that compares a comparison area of a reference X-ray image and a current X-ray image of a current patient location using pattern matching.

D. Miller, et. al. "Modular Patient Support System", U.S. Pat. No. 7,173,265 (Feb. 6, 2007) describe a radiation treatment system having a patient support system that includes a modularly expandable patient pod and at least one immobilization device, such as a moldable foam cradle.

K. Kato, et. al. "Multi-Leaf Collimator and Medical System Including Accelerator", U.S. Pat. No. 6,931,100 (Aug. 16, 2005); K. Kato, et. al. "Multi-Leaf Collimator and Medical System Including Accelerator", U.S. Pat. No. 6,823,045 (Nov. 23, 2004); K. Kato, et. al. "Multi-Leaf Collimator and Medical System Including Accelerator", U.S. Pat. No. 6,819,743 (Nov. 16, 2004); and K. Kato, et. al. "Multi-Leaf Collimator and Medical System Including Accelerator", U.S. Pat. No. 6,792,078 (Sep. 14, 2004) all describe a system of leaf plates used to shorten positioning time of a patient for irradiation therapy. Motor driving force is transmitted to a plurality of leaf plates at the same time through a pinion gear. The system also uses upper and lower air cylinders and upper and lower guides to position a patient.

Imaging

P. Adamee, et. al. "Charged Particle Beam Apparatus and Method for Operating the Same", U.S. Pat. No. 7,274,018 (Sep. 25, 2007) and P. Adamee, et. al. "Charged Particle Beam Apparatus and Method for Operating the Same", U.S. Pat.

No. 7,045,781 (May 16, 2006) describe a charged particle beam apparatus configured for serial and/or parallel imaging of an object.

K. Hiramoto, et. al. "Ion Beam Therapy System and its Couch Positioning System", U.S. Pat. No. 7,193,227 (Mar. 20, 2007) describe a ion beam therapy system having an X-ray imaging system moving in conjunction with a rotating gantry.

C. Maurer, et. al. "Apparatus and Method for Registration of Images to Physical Space Using a Weighted Combination of Points and Surfaces", U.S. Pat. No. 6,560,354 (May 6, 2003) described a process of X-ray computed tomography registered to physical measurements taken on the patient's body, where different body parts are given different weights. Weights are used in an iterative registration process to determine a rigid body transformation process, where the transformation function is used to assist surgical or stereotactic procedures.

M. Blair, et. al. "Proton Beam Digital Imaging System", U.S. Pat. No. 5,825,845 (Oct. 20, 1998) describe a proton beam digital imaging system having an X-ray source that is movable into the treatment beam line that can produce an X-ray beam through a region of the body. By comparison of the relative positions of the center of the beam in the patient orientation image and the isocentre in the master prescription image with respect to selected monuments, the amount and direction of movement of the patient to make the best beam center correspond to the target isocentre is determined.

S. Nishihara, et. al. "Therapeutic Apparatus", U.S. Pat. No. 5,039,867 (Aug. 13, 1991) describe a method and apparatus for positioning a therapeutic beam in which a first distance is determined on the basis of a first image, a second distance is determined on the basis of a second image, and the patient is moved to a therapy beam irradiation position on the basis of the first and second distances.

Problem

There exists in the art of particle beam treatment a need for an X-ray source that has a robust lifetime to minimize or eliminate downtime of the particle beam irradiation system due to a bad X-ray source. Further, there exists in the art of particle beam therapy of cancerous tumors a need for positioning and verification of proper positioning of a patient immediately prior to and/or concurrently with particle beam therapy irradiation to ensure targeted and controlled delivery of energy to the cancerous tumor with minimization of damage to surrounding healthy tissue.

SUMMARY OF THE INVENTION

The invention comprises an X-ray method and apparatus used in conjunction with charged particle beam radiation therapy of cancerous tumors.

DESCRIPTION OF THE FIGURES

FIG. 1 illustrates sub-system connections of a particle beam therapy system;

FIG. 2 illustrates a synchrotron;

FIG. 3 illustrates an X-ray source having an elongated lifetime coupled to a particle beam therapy system;

FIG. 4 illustrates an X-ray source proximate a particle beam path;

FIG. 5 illustrates an expanded X-ray beam path; and

FIG. 6 illustrates geometry of an electron beam path and an X-ray beam path.

DETAILED DESCRIPTION OF THE INVENTION

The invention comprises an X-ray method and apparatus used in conjunction with charged particle beam radiation therapy of cancerous tumors.

The system uses an X-ray imaging system having an elongated lifetime. Further, the system uses an X-ray beam that lies in substantially the same path as a charged particle beam path of a particle beam cancer therapy system. The system creates an electron beam that strikes an X-ray generation source where the X-ray generation source is located proximate to the charged particle beam path. By generating the X-rays near the charged particle beam path, an X-ray path running collinear, in parallel with, and/or substantially in contact with the charged particle beam path is created. The system then collects X-ray images of localized body tissue region about a cancerous tumor. Since, the X-ray path is essentially the charged particle beam path, the generated image is usable for fine tuning body alignment relative to the charged particle beam path, is used to control the charged particle beam path to accurately and precisely target the tumor, and/or is used in system verification and validation.

Accurate and precise delivery of protons to a tumor in body tissue is critical in charged particle beam therapy. Complicating accurate and precise deliver is natural movement of the body. Movement of the body occurs on multiple levels, including: (1) general movement; (2) standing, sitting, or lying position variation; and (3) relative movement of internal body parts, such as organs. All of these movements change with time. Hence, a method of determining position of elements of the body at or in close proximity in time to the charged particle therapy is needed, such as after the body is positioned relative to a charged particle beam. Herein, an X-ray positioning and/or verification method and apparatus used in conjunction with charged particle therapy is described.

Charged Particle Beam Therapy

Throughout this document, a charged particle beam therapy system, such as a proton beam, hydrogen ion beam, or carbon ion beam, is described. Herein, the charged particle beam therapy system is described using a proton beam. However, the aspects taught and described in terms of a proton beam are not intended to be limiting to that of a proton beam and are illustrative of a charged particle beam system. Any charged particle beam system is equally applicable to the techniques described herein.

Referring now to FIG. 1, a charged particle beam system **100** is illustrated. A charged particle beam, preferably comprises a number of subsystems including any of: a main controller **110**; an injection system **120**; a synchrotron **130** that typically includes: (1) an accelerator system **132** and (2) an extraction system **134**; a targeting/delivery system **140**; a patient interface module **150**; a display system **160**; and/or an imaging system **170**.

An exemplary method of use of the charged particle beam system **100** is provided. The main controller **110** controls one or more of the subsystems to accurately and precisely deliver protons to a tumor of a patient. For example, the main controller **110** obtains an image, such as a portion of a body and/or of a tumor, from the imaging system **170**. The main controller **110** also obtains position and/or timing information from the patient interface module **150**. The main controller **110** then optionally controls the injection system **120** to inject a proton into a synchrotron **130**. The synchrotron typically contains at least an accelerator system **132** and an extraction system **134**. The main controller preferably controls the proton beam within the accelerator system, such as

by controlling speed, trajectory, and timing of the proton beam. The main controller then controls extraction of a proton beam from the accelerator through the extraction system **134**. For example, the controller controls timing, energy, and intensity of the extracted beam. The controller **110** also preferably controls targeting of the proton beam through the targeting/delivery system **140** to the patient interface module **150**. One or more components of the patient interface module **150** are preferably controlled by the main controller **110**; Further, display elements of the display system **160** are preferably controlled via the main controller **110**. Displays, such as display screens, are typically provided to one or more operators and/or to one or more patients. In one embodiment, the main controller **110** times the delivery of the proton beam from all systems, such that protons are delivered in an optimal therapeutic manner to the patient.

Herein, the main controller **110** refers to a single system controlling the charged particle beam system **100**, to a single controller controlling a plurality of subsystems controlling the charged particle beam system **100**, or to a plurality of individual controllers controlling one or more sub-systems of the charged particle beam system **100**.

Synchrotron

Herein, the term synchrotron is used to refer to a system maintaining the charged particle beam in a circulating path; however, cyclotrons are alternatively used, albeit with their inherent limitations of energy, intensity, and extraction control. Further, the charged particle beam is referred to herein as circulating along a circulating path about a central point of the synchrotron. The circulating path is alternatively referred to as an orbiting path; however, the orbiting path does not refer to a perfect circle or ellipse, rather it refers to cycling of the protons around a central region.

Referring now to FIG. 2, an illustrative exemplary embodiment of one version of the charged particle beam system **100** is provided. In the illustrated embodiment, a charged particle beam source **210** generates protons. The protons are delivered into a vacuum tube that runs into, through, and out of the synchrotron. The generated protons are delivered along an initial path **220**. Focusing magnets **230**, such as quadrupole magnets or injection quadrupole magnets, are used to focus the proton beam path. A quadrupole magnet is a focusing magnet. An injector bending magnet **232** bends the proton beam toward the plane of the synchrotron **130**. The focused protons having an initial energy are introduced into an injector magnet **240**, which is preferably an injection Lamberson magnet. Typically, the initial beam path **262** is along an axis off of, such as above, a circulating plane of the synchrotron **130**. The injector bending magnet **232** and injector magnet **240** combine to move the protons into the synchrotron **130**. Circulating magnets or main bending magnets **250** are used to turn the protons along a circulating beam path **260**. The circulating magnets **250** bend the original beam path **220** into a circulating beam path **260**. In this example, the circulating magnets **250** are represented as four sets of four magnets to maintain the circulating beam path **260** into a stable circulating beam path. A plurality of main bending magnets make up a turning section of the synchrotron. In the illustrated exemplary embodiment, four main bending magnets make up a turning section turning the proton beam about ninety degrees. Optionally, any number of magnets or sets of magnets are optionally used to move the protons around a single orbit in the circulation process. The protons pass through an accelerator **270**. The accelerator accelerates the protons in the beam path **260**. As the protons are accelerated, the fields applied by the magnets are increased. Particularly, the speed of the protons achieved by the accelerator **270** are synchro-

nized with magnetic fields of the circulating magnets **250** to maintain stable circulation of the protons about a central point or region **280** of the synchrotron. At separate points in time the accelerator **270**/circulating magnet **250** combination is used to accelerate and/or decelerate the circulating protons. An extraction system **290** is used in combination with a deflector **300** to remove protons from their circulating path **260** within the synchrotron **190**. One example of a deflector component is a Lamberson magnet. Typically the deflector moves the protons from the circulating plane to an axis off of the circulating plane, such as above the circulating plane. Extracted protons are preferably directed and/or focused using an extraction bending magnet **237** and extraction focusing magnets **235**, such as quadrupole magnets along a transport path into the scanning/targeting/delivery system **160**. Two components of a targeting system **160** typically include a first axis control **162**, such as a vertical control, and a second axis control **164**, such as a horizontal control. Protons are delivered with control to the patient interface module **170** and to a tumor of a patient. Preferably no quadrupoles are used in or around the circulating path of the synchrotron.

Imaging System

Herein, an X-ray generation system is described.

Lifetime

It is desirable to have components in the particle beam therapy system that require minimal or no maintenance over the lifetime of the particle beam therapy system. For example, it is desirable to equip the proton beam therapy system with an X-ray system having a long lifetime source, such as a lifetime of about 20 years.

In one system, described infra, electrons are used to create X-rays. The electrons are generated at a cathode where the lifetime of the cathode is temperature dependent. Analogous to a light bulb, where the filament is kept in equilibrium, the cathode temperature is held in equilibrium at temperatures at about 200, 500, or 1000 degrees Celsius. Reduction of the cathode temperature results in increased lifetime of the cathode. Hence, the cathode used in generating the electrons is preferably held at as low of a temperature as possible. However, if the temperature of the cathode is reduced, then electron emissions also decrease. To overcome the need for more electrons at lower temperatures, a large cathode is used and the generated electrons are concentrated. The process is analogous to compressing electrons in an electron gun; however, here the compression techniques are adapted to apply to enhancing an X-ray tube lifetime.

Referring now to FIG. 3, an example of an X-ray generation device **300** having an enhanced lifetime is provided. Electrons **320** are generated at a cathode **310**, focused with a control electrode **330**, and accelerated with a series of accelerating electrodes **340**. The accelerated electrons **350** impact an X-ray generation source or X-ray generating anode **348** resulting in generated X-rays that are then directed along an X-ray path **470** to the subject **430**. The concentrating of the electrons from a first diameter **312** to a second diameter **316** allows the cathode to operate at a reduced temperature and still yield the necessary amplified level of electrons at the X-ray generation source **348**.

Still referring to FIG. 3, a more detailed description of an exemplary X-ray generation device **300** is described. An anode **314**/cathode **310** pair is used to generate electrons. The electrons **320** are generated at the cathode **310** having a first diameter **312**, which is denoted d_1 . The control electrodes **330** attract the generated electrons **320**. For example, if the cathode is held at about -150 kV and the control electrode is held at about -149 kV, then the generated electrons **320** are attracted toward the control electrodes **330** and focused. A

series of accelerating electrodes **340** are then used to accelerate the electrons into a substantially parallel path **350** with a smaller diameter **316**, which is denoted d_2 . For example, with the cathode held at -150 kV, a first, second, third, and fourth accelerating electrode **342**, **344**, **346**, **348** are held at about -120 , -90 , -60 , and -30 kV, respectively. If a thinner body part is to be analyzed, then the cathode **310** is held at a smaller level, such as about -90 kV and the control electrode, first, second, third, and fourth electrode are each adjusted to lower levels.

Generally, the voltage difference from the cathode to fourth electrode is less for a smaller negative voltage at the cathode and vice-versa. The accelerated electrons **350** are optionally passed through a magnetic lens **360** for adjustment of beam size, such as a cylindrical magnetic lens. The electrons are also optionally focused using quadrupole magnets **370**, which focus in one direction and defocus in another direction. The accelerated electrons **350**, which are now adjusted in beam size and focused strike an X-ray generation source **348**, such as tungsten, resulting in generated X-rays that pass through an optional blocker **462** and proceed along an X-ray path **470** to the subject. The X-ray generation source **348** is optionally cooled with a cooling element **349**, such as water touching or thermally connected to a backside of the X-ray generation source **348**. The concentrating of the electrons from a first diameter **312** to a second diameter **316** allows the cathode to operate at a reduced temperature and still yield the necessary amplified level of electrons at the X-ray generation source **348**.

More generally, the X-ray generation device **300** produces electrons having initial vectors. One or more of the control electrode **330**, accelerating electrodes **340**, magnetic lens **360**, and quadrupole magnets **370** combine to alter the initial electron vectors into parallel vectors with a decreased cross-sectional area having a substantially parallel path, referred to as the accelerated electrons **350**. The process allows the X-ray generation device **300** to operate at a lower temperature. Particularly, instead of using a cathode that is the size of the electron beam needed, a larger electrode is used and the resulting electrons **320** are focused and/or concentrated into the required electron beam needed. As lifetime is roughly an inverse of current density, the concentration of the current density results in a larger lifetime of the X-ray generation device. A specific example is provided for clarity. If the cathode has a 15 mm radius or d_1 is about 30 mm, then the area (πr^2) is about 225 mm² times π . If the concentration of the electrons achieves a radius of 5 mm or d_2 is about 10 mm, then the area (πr^2) is about 25 mm² times π . The ratio of the two areas is about 9 ($225\pi/25\pi$).

Thus, there is about 9 times less density of current at the larger cathode compared to the traditional cathode having an area of the desired electron beam. Hence, the lifetime of the larger cathode approximates 9 times the lifetime of the traditional cathode, though the actual current through the larger cathode and traditional cathode is about the same. Preferably, the area of the cathode **310** is about 2 , 4 , 6 , 8 , 10 , 15 , 20 , or 25 times that of the cross-sectional area of the substantially parallel electron beam **350**.

In another embodiment of the invention, the quadrupole magnets or quads **370** result in an oblong cross-sectional shape of the electron beam **350**. A projection of the oblong cross-sectional shape of the electron beam **350** onto the X-ray generation source **348** results in an X-ray beam that has a small spot cross-sectional shape, which is preferably substantially circular in cross-sectional shape, that is then passed through the patient **430**. The small spot is used to yield an X-ray having enhanced resolution at the patient.

In yet another embodiment of the invention, the control electrode **330** is used to turn on and off the X-ray source in synchronization with breathing. For instance, X-rays are generated when the patient is at the bottom of a breath so that the generated X-ray images are collected when the internal organs, bones, and structures of the patient are in reproducible positions or are in reproducible relative positions. Accurate and precise delivery of protons to a tumor in body tissue is critical in charged particle beam therapy. Complicating accurate and precise delivery is natural movement of the body. Movement of the body occurs on multiple levels, including: (1) general patient movement, such as walking; (2) standing, sitting, or lying position variation; and (3) relative movement of internal body parts, such as organs. All of these movements change with time. Hence, the X-ray method of determining position of elements of the body at and/or in close proximity in time to the charged particle therapy, such as after the body is positioned relative to a charged particle beam, is used to provide reference images for optimal proton therapy treatment. Hence, the X-ray generations system is used as a positioning and/or verification method and apparatus used in conjunction with charged particle therapy.

Timing

An X-ray is preferably collected either (1) just before or (2) concurrently with treating a subject with proton therapy for a couple of reasons.

First, movement of the body, described supra, changes the local position of the tumor in the body. If the subject has an X-ray taken and is then bodily moved to a proton treatment room, accurate alignment of the proton beam to the tumor is problematic. Alignment of the proton beam to the tumor using one or more X-rays is best performed at the time of proton delivery or in the seconds or minutes immediately prior to proton delivery and after the patient is placed into a therapeutic body position, which is typically a fixed position.

Second, the X-ray taken after positioning the patient is used for verification of proton beam alignment to a targeted position, such as a tumor and/or internal organ position.

Positioning

An X-ray is preferably taken just before treating the subject to aid in patient positioning. For positioning purposes, an X-ray of a large body area is not needed. In one embodiment, an X-ray of only a local area is collected. When collecting an X-ray, the X-ray has an X-ray path. The proton beam has a proton beam path. Overlaying the X-ray path with the proton beam path is one method of aligning the proton beam to the tumor. However, this method involves putting the X-ray equipment into the proton beam path, taking the X-ray, and then moving the X-ray equipment out of the beam path. This process takes time. The elapsed time while the X-ray equipment moves has a couple of detrimental effects. First, during the time required to move the X-ray equipment, the body moves. The resulting movement decreases precision and accuracy of subsequent proton beam alignment to the tumor. Second, the time required to move the X-ray equipment is time that the proton beam therapy system is not in use, which decreases the total efficiency of the proton beam therapy system.

Referring now to FIG. 4, in one embodiment, an X-ray is generated close to, but not in, the proton beam path. A proton beam therapy system and an X-ray system combination **400** is illustrated in FIG. 4. The proton beam therapy system has a proton beam **260** in a transport system after the deflector **292** of the synchrotron **130**. The proton beam is directed by the targeting/delivery system **140** to a tumor **420** of a patient **430**. The X-ray generation system **300** includes an electron beam source generating **305** an electron beam **350**. The electron

beam is directed to an X-ray generation source 348, such as a piece of tungsten. Preferably, the tungsten X-ray source is located about 1, 2, 3, 5, 10, or 20 millimeters from the proton beam path 260. When the electron beam 350 hits the tungsten, X-rays are generated in all directions. X-rays are blocked with a port 462 and are selected for an X-ray beam path 470. The X-ray beam path 470 and proton beam path 269 run substantially in parallel from the X-ray generation source 348 to the tumor 420. The distance between the X-ray beam path 470 and proton beam path 269 diminishes to near zero and/or the X-ray beam path 470 and proton beam path 269 preferably overlap by the time they reach the tumor 420. Simple geometry shows this to be the case given the long distance, of at least a meter, between the tungsten and the tumor 420. The distance is illustrated as a gap 480 in FIG. 4. The X-rays are detected at an X-ray detector 490, which is used to form an image of the tumor 420 and/or position of the patient 430.

Referring now to FIG. 5, additional geometry of the electron beam path 350 and X-ray beam path 370 shown in FIGS. 3 and 4 is presented. Particularly, the electron beam 350 is shown as an expanded beam path 352, 354. Also, the X-ray beam path 470 is shown as an expanded beam path 472, 474. Still further, the proton beam path 261 is illustratively shown as scanning from the bottom of the tumor along a lower proton beam path 353 to the top of the tumor along an upper proton beam path 355. The region 505 where the electron beam 350 hits the X-ray generation source 348 to yield X-rays and an X-ray beam 370 is expanded in FIG. 6.

Referring now to FIG. 6, additional geometry of the electron beam path 350 and X-ray beam path 370 is illustrated. The electron beam cross section 610 is generally of an oblong or elliptical shape. For example, the illustrated electron beam cross section 610 has a height 614 of about three millimeters and a width 612 of about ten millimeters. The oblong shape of electrons hits the X-ray generation source 348, which is set at an angle alpha 620 off of the proton beam path 260. An exemplary angle alpha is about fifteen degrees, less preferably about five to forty-five degrees, or about 5, 10, 15, 20, 25, 30, or 35 degrees. Generated X-rays are blocked with a port 462. As a result of the geometry of the electron beam path 350, X-ray generation source 348, angle alpha 620, and port 462, the resulting X-ray beam path 370 has an illustrated cross-sectional profile 640 that is generally spot shaped having a height 644 and a width 642. For example, the height 644 is about three millimeters and the width of the spot 642 is about three millimeters.

Still referring to FIG. 6, more generally the electron beam path 350, X-ray generation source 348, angle alpha 620, and port 462 are optionally configured to result in the spot 640 being an ellipse or rectangular cross section of any dimension. For example, the electron beam path is optionally controlled to have a width of about 1 to 10 millimeter and a height of about 1 to 20 millimeters to result in a spot 640 having a diameter of about 0.5, 1, 2, 4, or 10 millimeters or to have a rectangular shape with sides of about 1, 2, 5, or 10 millimeters. Further, the system allows the X-ray beam path 470 to expand in cross sectional dimension as the path approaches the tumor 420 to allow for imaging of the tumor.

The X-ray generation source, or tungsten material, is preferably cooled with a cooling element 349. The cooling element 349 is preferably a chamber containing a coolant, such as water, a water or alcohol based solution, or a solution containing ethylene glycol. The cooling system is preferably in direct thermal contact with a back side of the tungsten, where the front side of the tungsten is impacted by the electron beam 350 in generation of the X-ray beam 470. The coolant is contained in a container. The coolant is passive,

internally circulated, or circulated through an external heat exchange unit. The cooling system alternatively uses heat sinks to remove heat from the tungsten with or without the liquid cooling system.

As a whole, the system generates an X-ray beam that lies in substantially the same path as the proton therapy beam. The X-ray beam is generated by striking a tungsten or equivalent material with an electron beam. The X-ray generation source is located proximate to the proton beam path. Geometry of the incident electrons, geometry of the X-ray generation material, and geometry of the X-ray beam blocker yield an X-ray beam that runs either substantially in parallel with the proton beam or results in an X-ray beam path that starts proximate the proton beam path and expands to cover and transmit through a tumor cross-sectional area to strike an X-ray detector array or film allowing imaging of the tumor from a direction and alignment of the proton therapy beam. The X-ray image is then used to control the charged particle beam path to accurately and precisely target the tumor, and/or is used in system verification and validation.

Although the invention has been described herein with reference to certain preferred embodiments, one skilled in the art will readily appreciate that other applications may be substituted for those set forth herein without departing from the spirit and scope of the present invention. Accordingly, the invention should only be limited by the Claims included below.

The invention claimed is:

1. An X-ray apparatus as part of a particle beam cancer therapy system, said particle beam cancer therapy system irradiating a tumor of a patient with a charged particle beam during use, said apparatus comprising:

an electron generating cathode;

a control electrode;

a plurality of accelerating electrodes;

a magnetic lens;

a quadrupole magnet, all of said control electrode, said accelerating electrodes, said magnetic lens, and said quadrupole magnet located between said cathode and an X-ray generating anode, said control electrode, said accelerating electrodes, said magnetic lens, and said quadrupole magnet combining to form a substantially parallel electron beam with an electron beam cross-sectional area, wherein a cross-sectional area of said cathode is greater than about six times that of the electron beam cross-sectional area; and

a synchrotron configured to accelerate the charged particle beam,

wherein said anode comprises a location within about forty millimeters of the charged particle beam,

wherein the tumor is targeted using X-ray images collected using X-rays from said X-ray generating anode,

wherein the tumor is treated using the charged particle beam, and

wherein the X-rays run substantially in parallel with the charged particle beam.

2. The apparatus of claim 1, wherein the electron beam comprises an oblong cross-sectional shape resultant from said quadrupole magnet, wherein X-rays generated at said anode comprise an about circular cross-sectional shape.

3. The apparatus of claim 1, wherein power to said control electrode comprises synchronization to respiration of the patient.

4. The apparatus of claim 1, wherein said X-ray generating anode comprises a location within about twenty millimeters of the charged particle beam.

17

5. The apparatus of claim 4, wherein said X-ray generating anode maintains a single static position:

- (1) during use of said X-ray generating anode; and
- (2) during tumor treatment with the charged particle beam.

6. The apparatus of claim 1, wherein use of said X-ray generating anode occurs within thirty seconds of subsequent use of the charged particle beam for tumor therapy.

7. The apparatus of claim 1, wherein said synchrotron comprises:

- exactly four turning sections; and
- no quadrupoles in the circulating path of the synchrotron.

8. The apparatus of claim 1, wherein said synchrotron comprises:

- exactly four, ninety degree, turning sections.

9. An X-ray method as part of a particle beam cancer therapy system, said particle beam cancer therapy system irradiating a tumor of a patient with a charged particle beam during use, said method comprising the steps of:

generating X-rays with an X-ray generation source, said X-ray generation source comprising:

- an electron generating cathode;
- a control electrode;
- a plurality of accelerating electrodes;
- a magnetic lens; and

a quadrupole magnet, all of said control electrode, said accelerating electrodes, said magnetic lens, and said quadrupole magnet located between said cathode and an anode, said control electrode, said accelerating electrodes, said magnetic lens, and said quadrupole magnet combining to form a substantially parallel electron beam with an electron beam cross-sectional area, wherein a cross-sectional area of said cathode is greater than about six times that of the electron beam cross-sectional area;

accelerating the charged particle beam with a synchrotron; targeting the tumor using X-ray images collected using

X-rays from said X-ray generation source; and treating the tumor using the charged particle beam, wherein the X-rays are generated by the electrons from said cathode striking said anode, and wherein the X-rays emitted from said anode run substantially in parallel with the charged particle beam.

10. The method of claim 9, wherein the electron beam comprises an oblong cross-sectional shape resultant from said quadrupole magnet, wherein the X-rays generated at said anode comprise an about circular cross-sectional shape.

18

11. The method of claim 9, wherein said anode comprises a location within about forty millimeters of the charged particle beam.

12. The method of claim 9, further comprising the step of: synchronizing generation of the X-rays to respiration of the patient.

13. The method of claim 9, wherein said X-ray source maintains a single static position:

- (1) during use of said X-ray source; and
- (2) during tumor treatment with the charged particle beam.

14. The method of claim 9, wherein said anode comprises a tungsten anode.

15. The method of claim 14, further comprising the step of: generating electrons with said cathode, said cathode having a first cross-sectional distance.

16. The method of claim 15, further comprising the steps of:

focusing the electrons from said first cross-sectional distance to a second cross-sectional distance with said focusing control electrode; and accelerating the electrons with said accelerating electrodes.

17. The method of claim 16, further comprising the step of: forming a substantially circular cross-section X-ray beam, wherein said substantially parallel electron beam comprises an oblong cross-sectional shape, wherein geometry of said X-ray generation source yields the substantially circular cross section X-ray when struck by the electron beam having said oblong cross-sectional shape, the X-ray beam running substantially in parallel with the charged particle beam.

18. The method of claim 17, further comprising the step of: cooling said tungsten anode with a cooling element connected to a backside of said tungsten anode.

19. The method of claim 9, further comprising the step of: using said X-ray generation source within thirty seconds of subsequent use of the charged particle beam for tumor therapy.

20. The method of claim 9, wherein said synchrotron comprises:

- exactly four turning sections; and
- no quadrupoles in the circulating path of the synchrotron.

21. The method of claim 9, wherein said synchrotron comprises:

- exactly four, ninety degree, turning sections.

* * * * *