

H. Dotzenroth,

Reversible Lathe.

No. 110,637.

Patented Jan. 3, 1871.

Fig. 1.

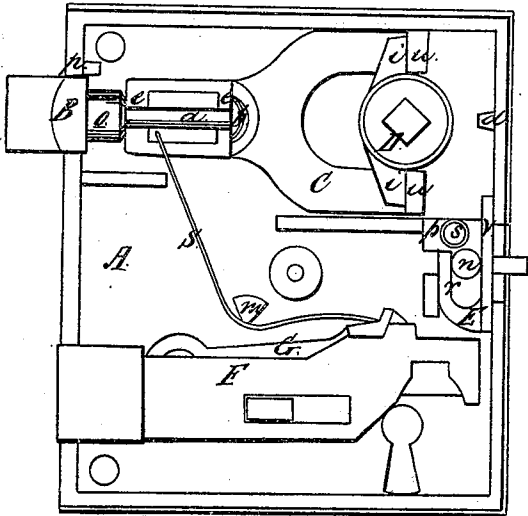

Fig. 2.

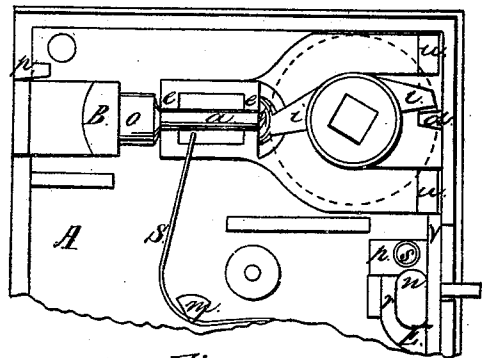
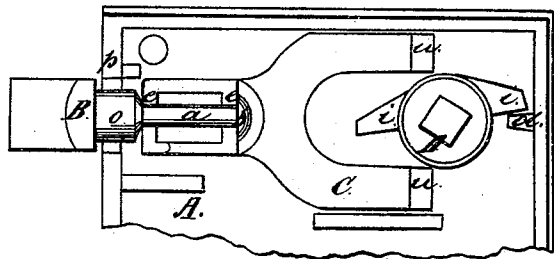

Fig. 3.



Witnesses
G. W. Nichols
C. F. Knauer.

Inventor,
H. Dotzenroth

United States Patent Office.

HEINRICH DOTZENROTH, OF PITTSBURG, PENNSYLVANIA.

Letters Patent No. 110,637, dated January 3, 1871.

IMPROVEMENT IN REVERSIBLE LATCHES.

The Schedule referred to in these Letters Patent and making part of the same.

To all whom it may concern:

Be it known that I, HEINRICH DOTZENROTH, of Pittsburg, in the county of Allegheny and State of Pennsylvania, have invented a new and improved Mode for Reversing Lock-Latches; and I do hereby declare that the following is a full, clear, and exact description of the construction and operation of the same, reference being had to the annexed drawing making a part of this specification, in which—

Figures 1, 2, and 3 are top views of the lock with the plate removed.

The invention relates to reversible latches, and consists in the construction of a sliding stop, with reference to the latch and case, as hereinafter set forth.

A represents the case;

B, the reversible latch, which is swiveled in the yoke C *u*;

D *i*, the follower for operating the yoke and latch; and

E, a vertically-sliding stop, which is provided with a lug projecting through a slot in the end of the case.

F is a sliding bolt, and

G, a stop or pivoted catch for locking the same when thrust out or drawn into the case.

S is a plate-spring, resting at one end on the stop-catch G, and at the other against a shoulder formed on the yoke C, while it bears centrally against an arm or projection, *m*, of the case.

The round shank *a* of the latch B rests in semi-circular grooves *e* in the end of the yoke, and has a head, *b*, and collar, *o*, which retain it in proper position.

s indicates a cylindrical projection on the stop E, which is surrounded by a spiral spring, whose pressure serves to retain said stop in the desired position.

n indicates a hole, in which a screw is inserted for securing the lock to the door.

The latch cannot be pushed in to be reversed unless the screw be removed, so that the stop E may be moved down out of the way.

The operation is as follows:

While the stop E occupies the position shown in fig. 1, its lateral flange V projects upward sufficiently to prevent the yoke being drawn back far enough to allow the latch B to be reversed; but, when pushed down, as in fig. 2, the follower may be turned to occupy the position indicated, (one of its arms *i* striking on the lug *d*,) when the yoke is left free to shoot forward, in which case the latch will project outside the case, so as to enable it to be reversed; after which it may be thrust back, and the follower turned to resume the position shown in fig. 1.

By pushing up the stop E till the part *r* intervenes between one of the ends *u* of the yoke and the end wall of the case, the latch will be locked so that it cannot be moved by means of the follower.

I claim as new and desire to secure by Letters Patent—

The sliding stop E, provided with the vertical flange *v* and front projection *r*, and arranged as shown, whereby the latch is prevented from sliding into the case to be disengaged from the follower D *i*, for the purpose of reversal, or locked in position, substantially as shown and described.

HEINRICH DOTZENROTH.

Witnesses:

G. W. NICHOLS,

C. F. KNAUER.