



US00D485515S

(12) **United States Design Patent**
Price

(10) **Patent No.:** **US D485,515 S**

(45) **Date of Patent:** **** Jan. 20, 2004**

(54) **LIGHTNING BOLT TRIM FOR MOTORCYCLE SIDE BAGS**

(76) **Inventor:** **Stephen A. Price**, 10623 Shadow La., Fairfax Station, VA (US) 22039

(**) **Term:** **14 Years**

(21) **Appl. No.:** **29/166,275**

(22) **Filed:** **Aug. 23, 2002**

(51) **LOC (7) Cl.** **12-11**

(52) **U.S. Cl.** **D12/114**

(58) **Field of Search** **D12/110, 114, D12/190, 407, 409, 410; 280/288.4; 180/219; 224/413, 419-435, 441-443, 447-449, 457; 296/37.1; 190/124-126**

(56) **References Cited**
PUBLICATIONS

Harley-Davidson® 1999 Genuine Motor Accessories™ & Genuine Motor Parts catalog, saddlebag trim on p. 255.*

* cited by examiner

Primary Examiner—Pamela Burgess
Assistant Examiner—Linda Brooks

(74) *Attorney, Agent, or Firm*—Dennis H. Lambert

(57) **CLAIM**

I claim the ornamental design for a lightning bolt trim for motorcycle side bags, as shown and described.

DESCRIPTION

FIG. 1 is a front, top perspective view of a first form of my lightning bolt trim for motorcycle side bags.

FIG. 2 is an enlarged transverse sectional view taken along line 2—2 in FIG. 1, to show the cross sectional shape of the design.

FIG. 3 is a top plan view of my design.

FIG. 4 is a side view in elevation of my design.

FIG. 5 is a rear view in elevation of my design.

FIG. 6 is a front view in elevation of my design.

FIG. 7 is a front, top perspective view of a second embodiment of my lightning bolt trim for motorcycle side bags; and,

FIG. 8 is an enlarged transverse sectional view taken along line 8—8 in FIG. 7, showing the modified cross sectional shape of my lightning bolt trim.

The broken line showing of environment is for illustrative purposes only and forms no part of the claimed invention.

1 Claim, 4 Drawing Sheets

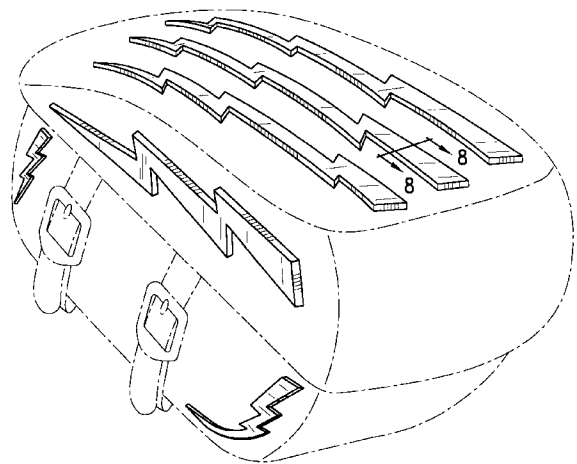
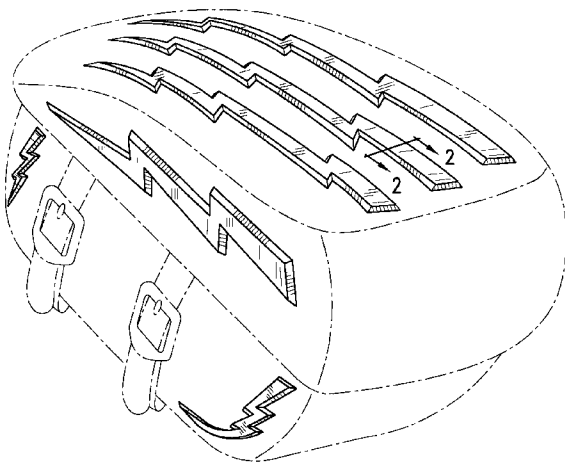

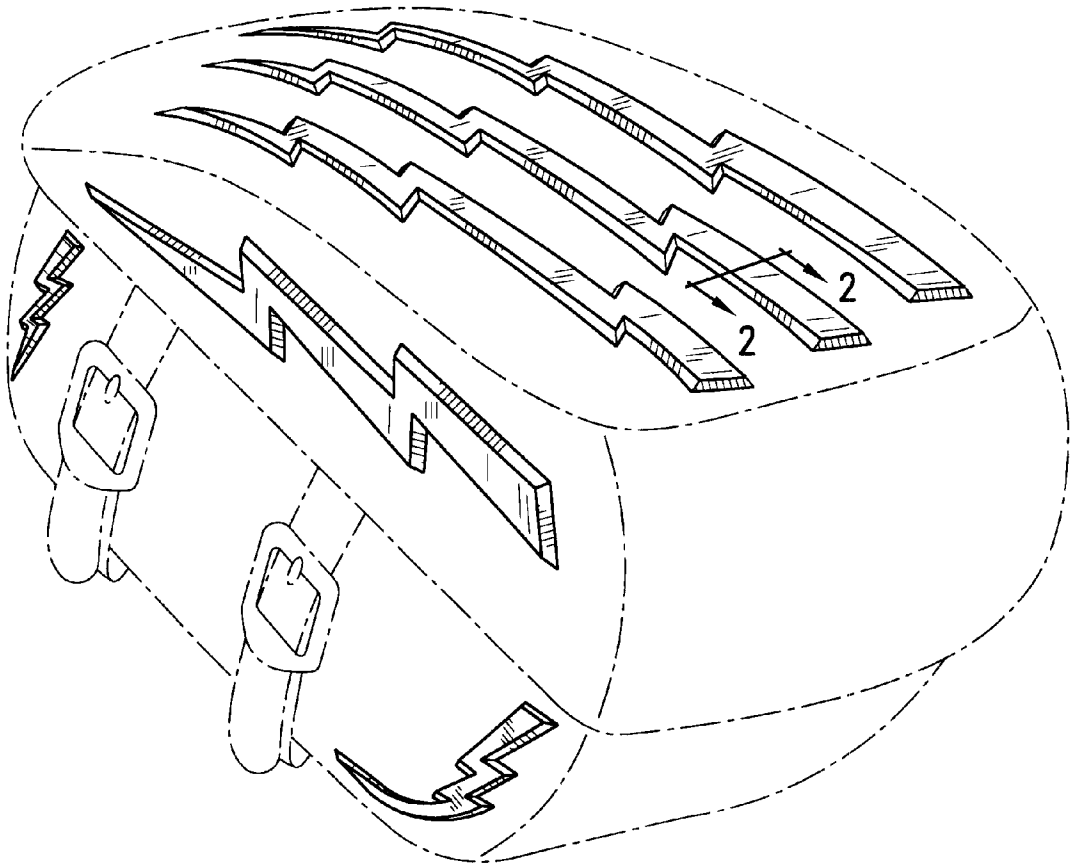

FIG. 1

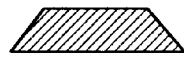

FIG. 2

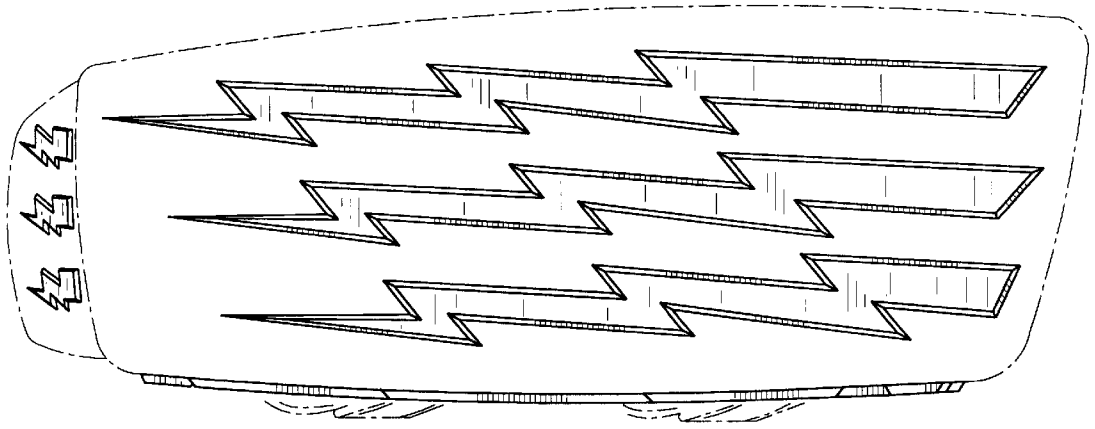

FIG.3

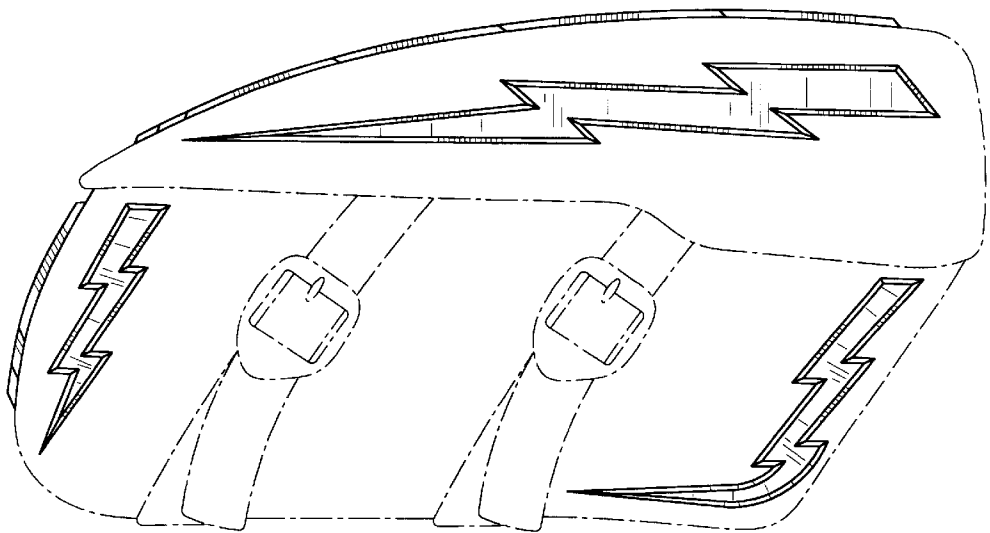

FIG.4

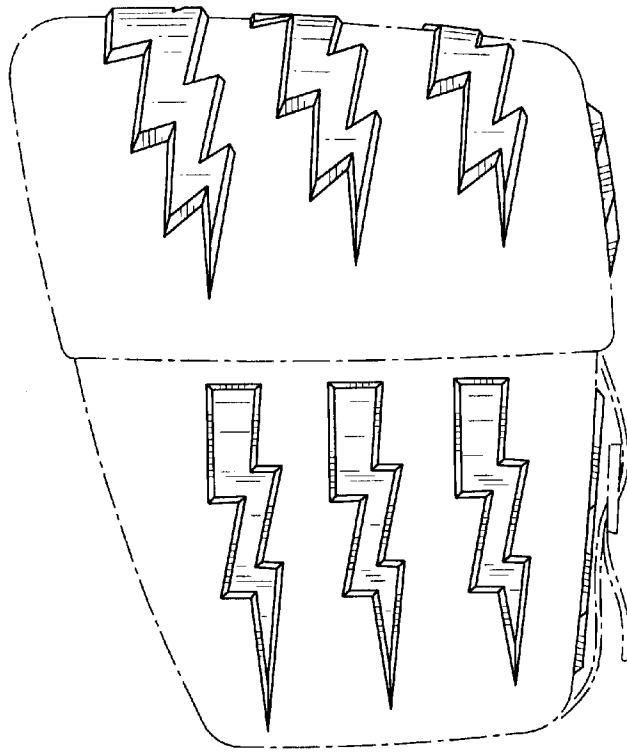

FIG.5

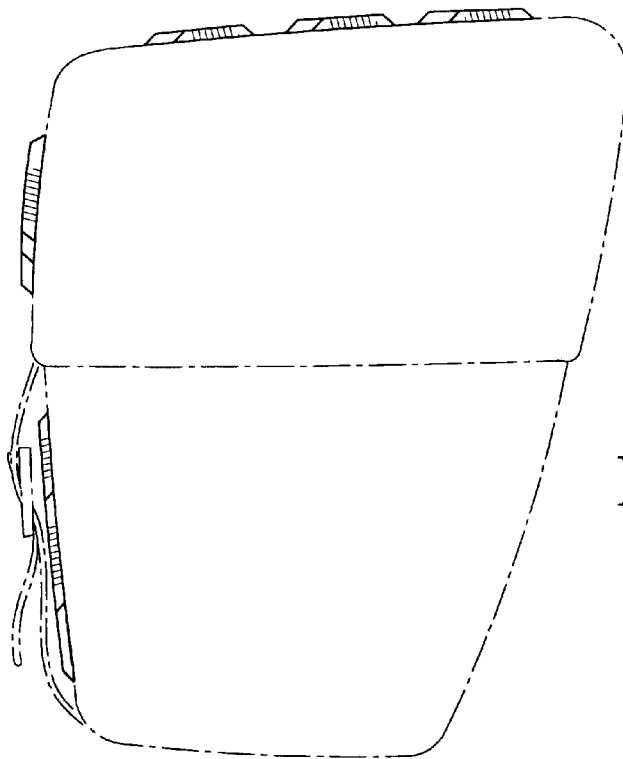

FIG.6

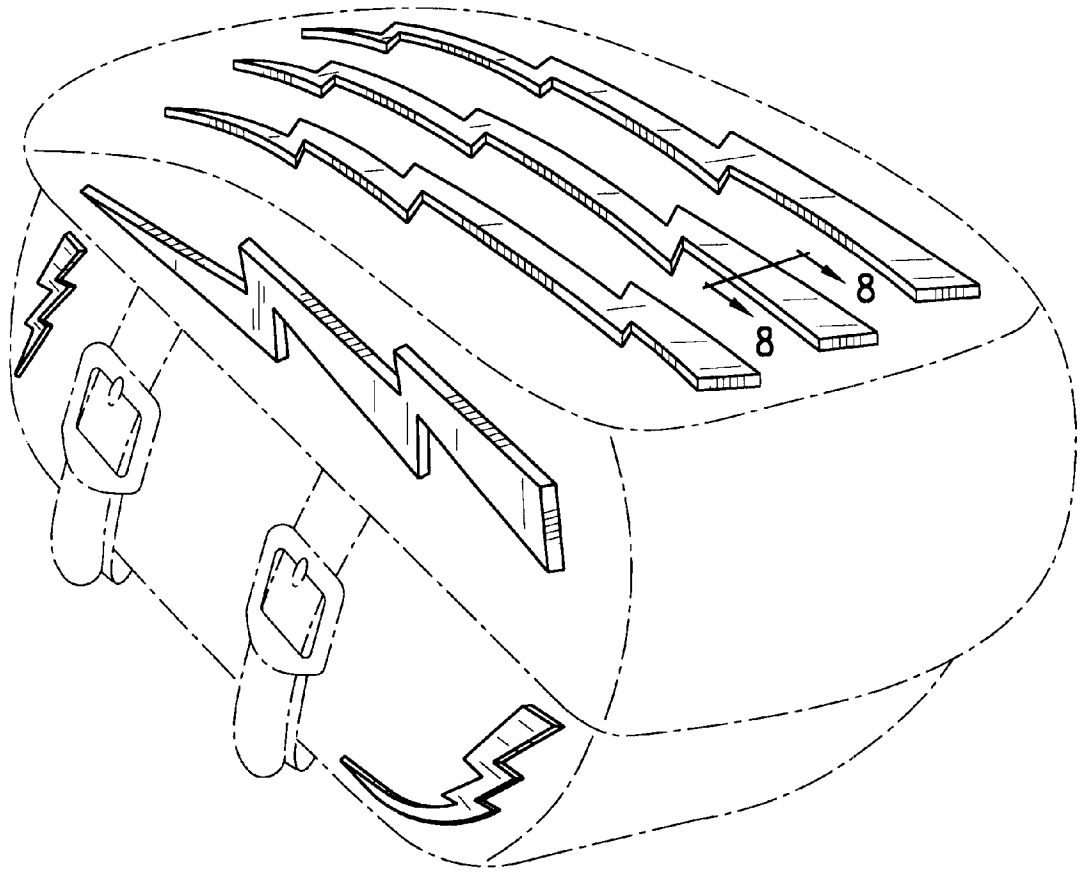

FIG. 7

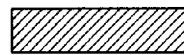

FIG. 8