



(51) International Patent Classification:

F01D 17/18 (2006.01) F16K 11/20 (2006.01)
F01D 25/24 (2006.01) F16K 27/02 (2006.01)

(21) International Application Number:

PCT/EP2020/065020

(22) International Filing Date:

29 May 2020 (29.05.2020)

(25) Filing Language:

English

(26) Publication Language:

English

(30) Priority Data:

19177692.1 31 May 2019 (31.05.2019) EP

(71) Applicant: **SIEMENS AKTIENGESELLSCHAFT**
[DE/DE]; Werner-von-Siemens-Str. 1, 80333 Munich (DE).

(72) Inventors: **BAMRAH, Devinder Singh**; 17, Pramukshwami Nagar No. 1, B/H Keya Motors, Chhani Jakat Naka, Vadodara, Gujarath 390024 (IN). **KAKAR, Sukesh**;

BPTP Park Grandeura, sector 82, faridabad, L303, Faridabad 121004 (IN). **KUMAR, Gaurav**; 6014/8 D6, Vasant Kunj, New Delhi 110070 (IN). **PAUL, Sayantan**; Flat number -263, Pocket-2, Sector -9, Dwarka, New Delhi 110075 (IN). **SHUKLA, Nidhi**; Plot number-4021, awas vikas-3, Kalyanpur road, Panki, Kanpur 208017 (IN). **SINGH, Paramdeep**; wz 480, street no 25, shivnagar, Delhi 110058 (IN).

(74) Agent: **PATENT ATTORNEYS WILHELM & BECK**; Prinzenstr. 13, 80639 Munich (DE).

(81) Designated States (unless otherwise indicated, for every kind of national protection available): AE, AG, AL, AM, AO, AT, AU, AZ, BA, BB, BG, BH, BN, BR, BW, BY, BZ, CA, CH, CL, CN, CO, CR, CU, CZ, DE, DJ, DK, DM, DO, DZ, EC, EE, EG, ES, FI, GB, GD, GE, GH, GM, GT, HN, HR, HU, ID, IL, IN, IR, IS, JO, JP, KE, KG, KH, KN, KP, KR, KW, KZ, LA, LC, LK, LR, LS, LU, LY, MA, MD, ME, MG, MK, MN, MW, MX, MY, MZ, NA, NG, NI, NO, NZ, OM, PA, PE, PG, PH, PL, PT, QA, RO, RS, RU, RW, SA,

(54) Title: CUSTOMISABLE CASING ARRANGEMENT FOR STEAM TURBINE

FIG 3A

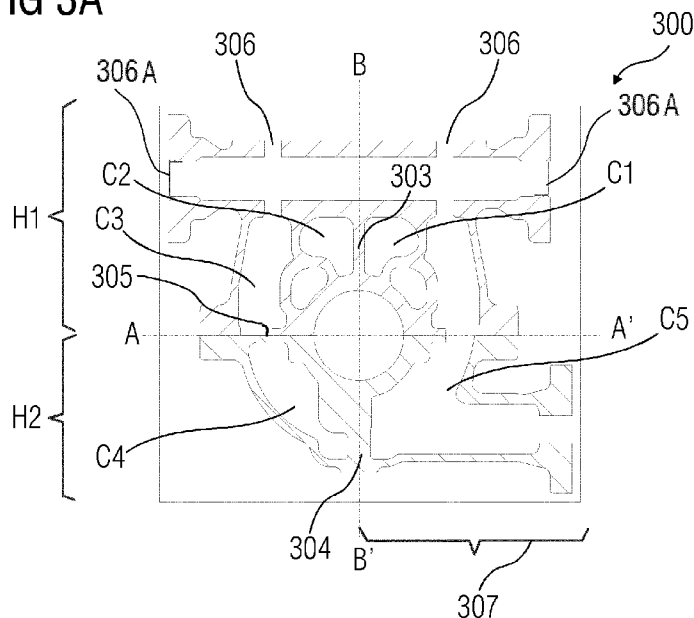

(57) Abstract: The present invention relates to a casing (300) for an inlet section of a steam turbine being in communication with a valve arrangement, said casing (300) comprising a plurality of chambers (C1-C5) for admitting steam into the turbine and a plurality of machineable wall elements (301, 302, 303, 304, 305). By machining selectively one or more of the machineable wall elements (301, 302, 303, 304, 305), the number of a number of chambers (C1-C5) within said casing (300) may be reduced in correspondence with a selected valve arrangement to be accommodated such as a single valve configuration or a multivalve arrangement. Thus, one standardised default casing may be customised to different application.



SC, SD, SE, SG, SK, SL, ST, SV, SY, TH, TJ, TM, TN, TR,
TT, TZ, UA, UG, US, UZ, VC, VN, WS, ZA, ZM, ZW.

(84) Designated States (*unless otherwise indicated, for every kind of regional protection available*): ARIPO (BW, GH, GM, KE, LR, LS, MW, MZ, NA, RW, SD, SL, ST, SZ, TZ, UG, ZM, ZW), Eurasian (AM, AZ, BY, KG, KZ, RU, TJ, TM), European (AL, AT, BE, BG, CH, CY, CZ, DE, DK, EE, ES, FI, FR, GB, GR, HR, HU, IE, IS, IT, LT, LU, LV, MC, MK, MT, NL, NO, PL, PT, RO, RS, SE, SI, SK, SM, TR), OAPI (BF, BJ, CF, CG, CI, CM, GA, GN, GQ, GW, KM, ML, MR, NE, SN, TD, TG).

Published:

— *with international search report (Art. 21(3))*

CUSTOMISABLE CASING ARRANGEMENT FOR STEAM TURBINE

The present invention relates to a casing arrangement for a fluid power equipment, such as, a steam turbine. More particularly the present invention relates to a customizable casing arrangement customized for accommodating a governing valve or control valve of either single valve design or multi-valve design into the fluid power equipment, which control flow of the fluid, such as, steam into the steam turbine.

This patent application claims priority of European patent application EP 19 177 692.1, the disclosure of which is incorporated herein by reference.

Fluid power equipment, such as, steam turbines employed in industrial setups typically, employ valve arrangements, in order to regulate flow of steam according to load changes or to stop the flow of steam altogether. Such valve arrangements typically constitute arrangements controlling an inlet of the industrial steam via a single governing valve or a series of governing valves working in concert also known as multi-valve arrangements. Based on the valve arrangement and an inlet size of a steam turbine, the casing designs vary. For example, up to four variants may have to be designed. This leads to a longer delivery time, a higher inventory cost, a higher pattern cost, and an increased engineering effort.

US patent 6302644 B1 discloses a steam turbine, a method and a casting model for achieving a reduction in the casting models

and the modules, especially for the turbine casings by maintaining 2 control valves without a control stage and having a turbine outer casing of substantially identical design to a steam turbine having a control stage.

US patent 20150252681 A1 discloses machineable elements provided at fabrication stage such that, the construction has an inner shell and an outer shell and inner shell axial locations are selectable to be machined to create an exhaust slot for allowing fluid to exit the inner shell cavity and enter the at least one closed chamber. Similarly, the outer shell has a second access region adjacent the closed chamber. The second access region includes outer shell axial locations selectable to be machined to create an exhaust opening fluidly connected with the closed chamber through the outer shell.

DE patent 4425352 A1 discloses machineable walls in a casing/housing with a conductive floor suspension and multiple extraction ports which are selectively machined such that the casing can be used for a counter-pressure turbine and a condensation turbine variant.

DE patent 19708273 C1 discloses a casing having a plurality of chambers, an intermediate wall machineable in accordance with respective requirements for steam injection or extraction by machining part of the intermediate wall.

FIG 1 illustrates a sectional view of a single valve arrangement 100 of fluid power equipment (not shown), for example, a steam turbine, of the state of the art, as mentioned above. The single valve arrangement 100 of the state of the art, is bulkier

compared to a multi-valve arrangement, as it requires additional space to accumulate volumetric flow of the steam required by the turbine. The single valve arrangement 100 comprises valves 101A, 101B, and 101C operated manually or pneumatically to manage different load points by controlling an amount of steam flow through an inner chamber 102. Moreover, in a single valve arrangement 100, the steam inlet flow 103 has to be maintained from one side only, for example, right hand side. This single valve arrangement 100 suits the customers who generally have a fixed direction of steam inflow. However, this single valve arrangement 100 poses limitations for those customers who need flexibility in the design due to the steam inlet being in the opposite direction to that of the inlet flow 103 of the single valve arrangement 100 of the state of the art. This leads to unnecessary loss of customer orders.

FIG 2 illustrates a sectional view of a multi valve arrangement 200 of a fluid power equipment, that is, a steam turbine, of the state of the art. The multi-valve arrangement comprises valves 201A-201C operated in concert with one another to control steam inlet flow in the steam turbine. According to the load control requirements of a customer, a single valve arrangement shown in FIG 1 or a multi-valve arrangement shown in FIG 2 is configured in a steam turbine.

At present, original equipment manufacturers (OEMs) do not maintain a significant inventory due to high number of variants required in the casing design. Typically, inlet casings of either single valve or multi-valve are procured as per order entry, from vendors, and then machined in-house or sourced back to vendors depending on factory loading. Typically, a single

valve arrangement is required for mechanical drive applications whereas a multi-valve arrangement is required for turbo-generator set applications. Additionally, a single valve arrangement is also preferred by customers in low capital investment market where customers prefer to run the turbine on single load-point for most parts of the season and will use the hand-valves when an increased power demand is there for short term durations during the season. As inlet casings are one of the longest lead items in an order, their sourcing and machining results in an increase in overall delivery time of the turbine.

Therefore, it is an object of the present invention to provide a casing arrangement to be employed, for example, in a fluid power equipment of the aforementioned kind, wherein the casing arrangement is simple in design, is cost effective, and is able to accommodate different variants of the valve arrangements including single valve and multi-valve arrangements with minimal alterations.

The casing arrangement disclosed in the present invention achieves the aforementioned object, in that the casing arrangement provides for one or more elements to be machined out easily based on valve arrangement configuration requirements.

Disclosed herein is a casing arrangement. The casing is provided for a fluid power equipment to control flow of fluid into the fluid power equipment. As used herein, "fluid power equipment" refers to turbomachinery, for example, a steam turbine. The term "casing" refers to an enclosure capable of housing rotors, blades there-within and controlling flow of the fluid in the fluid power equipment.

The casing disclosed herein comprises chambers within the casing, capable of controlling a fluid flowing through the fluid power equipment in communication with a valve arrangement, typically referred to as valve-chest. As used herein, "valve arrangement" refers to control valve arrangement controlling flow of the fluid through the fluid power equipment, such as, a steam turbine. According to one aspect, the valve arrangement is a single valve arrangement having up to three hand valves and a governing valve or a control valve. The governing valve or the control valve is actuator driven and each of the hand valves are operated manually, to control load points in a steam turbine, that is, flow of the steam. According to another aspect, the valve arrangement is a multi-valve arrangement having up to three valves that are operated in concert to control load points in a steam turbine, that is, flow of the steam and are controlled by actuators. Advantageously, there are at least five chambers available in the casing. There may be more than five chambers based on customization requirements to be made. The casing also includes machineable elements which when selectively machined from the casing alter a number of the chambers there-within resulting in multiple chamber arrangements thereby, allowing multiple solutions, that is, multiple valve arrangements to be adapted to, with flexibility. As used herein, the term "machineable" refers to an arrangement permitting removal of a material, for example, cutting of a metal. Also used herein, "elements" refer to one or more parts of the casing. According to one aspect of the present invention, the elements comprise, for example, walls such as inner walls, outer walls, partitioning walls that form chambers within the casing. According to another aspect of the present invention, the

elements also include physical dimensions of the walls such as a thickness of a wall, a height of the wall, etc. According to yet another aspect of the present invention, the elements also include holes punched through the walls of the casing for establishing fluid communication between a space enclosed within a chamber of the casing and a space outside the chamber, that is, in the remainder of the casing in a downstream direction of the fluid flow. The machineable walls when machined decrease the number of chambers within the casing. Advantageously, the machineable elements are selectively machined from the casing based on a valve arrangement to be accommodated in the fluid power equipment, based on application requirements. Advantageously, the number of chambers can vary from about three to at least five depending on the amount of flow which needs to be admitted in the turbine or the type of valve control required. For example, when four valves including three hand valves and a governing valve of a single valve arrangement is to be accommodated in the fluid power equipment, the machineable elements are machined so as to form four chambers. Similarly, when three valves of a multi-valve arrangement are to be accommodated in the fluid power equipment, the machineable elements are machined so as to form three chambers in the casing. Similarly, in cases of a low steam volume requirement, only an upper half of the casing can be used. In this scenario, the casing has six chambers by default. Without machining any machineable elements, the casing's upper half can be used for a single valve arrangement having four valves. With machining only one of the machineable elements, the casing's upper half can be used for a multi-valve arrangement having three valves. Thus, the casing is configurable to suit multiple load point requirements of a fluid power equipment.

According to one aspect of the invention, by default, the casing provided contains at least one hole and at least five chambers. The chambers are configured to be reduced in number by machining one or more elements of the casing thereby, combining the chambers, based on the valve arrangement to be accommodated in the fluid power equipment.

Advantageously, based on the number of chambers formed post machining of the elements, holes are machined, that is, punched through a top wall of the casing such that the total number of holes is equal to the number of valves for the valve arrangement being accommodated. The valves are then assembled through these holes.

Advantageously, one or more physical dimensions of the machineable elements of the casing are configured based on one or more fluid dynamics parameters associated with a fluid used in the fluid power equipment. The fluid dynamics parameters comprise, for example, a pressure of the fluid, a velocity of the fluid, a temperature of the fluid, a volumetric flow of the fluid, etc.

Typically, steam in the chambers that are in fluid communication with the valve arrangement, designated as valve-chest, will be used to feed the steam in the downstream section of the casing through a control section, for example, a nozzle-plate. An amount of steam to be admitted in a turbine is an outcome of a thermodynamic behavior of the turbine which is governed by steam characteristics comprising, for example, a steam velocity, a steam pressure, a steam temperature, etc. According to yet

another aspect of invention, the casing disclosed herein allows accommodation of nozzles in the nozzle-plate to be positioned anywhere along a diameter of the chambers in the valve-chest. Advantageously, the design of the casing with its chambers and flexible control section geometry achieved via the nozzle plate positioning provides freedom of configuring an optimized turbine using a single common casing and eliminating the need to have separate variants to handle different thermodynamic load cases based on application requirements.

The casing disclosed herein comprises an inflow member in fluid communication with one or more of the chambers and configurable to receive a fluid inflow into the casing. Advantageously, the inflow member is positioned so as to lead the fluid inflow into the chamber stretching across upper and lower halves of the casing. Advantageously, the casing disclosed herein is configurable to receive fluid inflow at least from each of opposing sides of the casing thereby, being effectively suited for a variety of customer requirements and installations. The casing when configured for a single valve arrangement can receive steam inlet flow from a bottom right side of the casing via the inflow member, a top right side of the casing, or a top left side of the casing. The casing when configured for a multi-valve arrangement can receive steam inlet flow from a top right side of the casing or a top left side of the casing.

Thus, the casing disclosed herein enables significant reduction in inventory management time and effort because by procuring a single casing the requirements of single and multi-valve

arrangements can be easily accommodated. This also leads to reduction in overall turbine costs and delivery time required per order. Moreover, flexibility of incorporating steam inlet entry for single valve arrangement from top left, from top right, or from bottom left increases customer base that can be catered to with minimal changes in the casing.

The above-mentioned and other features of the invention will now be addressed with reference to the accompanying drawings of the present invention. The illustrated embodiments are intended to illustrate, but not limit the invention.

The present invention is further described hereinafter with reference to illustrated embodiments shown in the accompanying drawings, in which:

FIG 1 illustrates a sectional view of a single valve arrangement of fluid power equipment, for example, a steam turbine, of the state of the art.

FIG 2 illustrates a sectional view of a multi valve arrangement of a fluid power equipment, that is, a steam turbine, of the state of the art.

FIGS 3A-3C illustrate sectional perspective views of a casing having machineable walls, according to an embodiment of the present invention.

FIG 4 illustrates a sectional elevation view of the casing shown in FIG 3B accommodating a single valve

arrangement, according to an embodiment of the present invention.

FIG 5 illustrates a sectional elevation view of the casing shown in FIG 3C accommodating a multi-valve arrangement, according to an embodiment of the present invention.

FIG 6A-6E illustrate various steam inlet flow arrangements achieved using the casing shown in FIGS 3A-3C.

Various embodiments are described with reference to the drawings, wherein like reference numerals are used to refer to like elements throughout. In the following description, for the purpose of explanation, numerous specific details are set forth in order to provide thorough understanding of one or more embodiments. It may be evident that such embodiments may be practiced without these specific details.

FIGS 3A-3C illustrate sectional perspective views of a casing 300 having machineable walls 303 and 304, according to an embodiment of the present invention.

FIG 3A illustrates a casing 300 configurable based on a single or a multi-valve arrangement to be accommodated in a fluid power equipment for which the casing is to be used. The casing 300 is provided by default and comprises about five chambers C1-C5. The chambers C1-C5 are configured to be reduced in number by machining one or more walls 303, 304, 305, etc., along orthogonal axes A-A' and B-B' passing centrally through the casing 300 thereby, combining one or more of the chambers C1-C5,

based on the valve arrangement to be accommodated. The chambers C1 and C2 have a machineable wall 303 there-between. The chambers C3 and C4 have a machineable wall 305 there-between. The chambers C4 and C5 have a machineable wall 304 there-between. The chambers C1, C2, and C3 are positioned entirely in an upper half H1 of the casing 300. The chamber C4 is positioned entirely in a lower half H2 of the casing 300. The chamber C5 is positioned so as to stretch through the upper half H1 and the lower half H2 of the casing 300. The casing 300 may also have one or more holes 306 by default providing a fluid communication passage into the chambers C3 and/or C5. The casing 300 comprises an inflow member 307 in fluid communication with the chamber C5. The inflow member 307 is positioned in the lower half H2 to allow fluid inlet from bottom right of the casing 300.

Alternatively, the casing 300 may comprise a sixth chamber C6 (not shown) formed by splitting the chamber C5 into two chambers by having a machineable wall (not shown) positioned along the horizontal axis A-A' corresponding to the position of the machineable wall 305. This arrangement allows the casing 300 to suit applications having a requirement for a low steam volume wherein, the chambers C1, C2, C3, and the sixth chamber (not shown) formed by splitting the chamber C5, that are lying in the upper half H1 of the casing 300 are put to use. The lower half H2 of the casing 300 remains unused. In this arrangement, the machineable wall 303 can be machined from the casing 300 based on the valve arrangement to be accommodated.

FIG 3B illustrates a casing 300 configured to accommodate a single valve arrangement. Therefore, the wall 304 shown in FIG 3A is machined out from the casing 300 thereby, creating

chambers 300A, 300B, 300C, and 300D in the casing 300. The chambers 300A, 300B, and 300C each accommodate a hand valve of the single valve arrangement therein for controlling the load points during operation of a steam turbine in which the casing 300 is to be used. The chamber 300D accommodates a governing valve (not shown) therein inserted into the casing 300 which is mounted at an inlet flange (not shown) of the casing 300. One of the hand valves is inserted through the other hole 306 so as to be in fluid communication with the chamber 300C. Additional holes 301 are also machined from the casing 300 through which the hand valves are then inserted and installed in the casing 300 so as to be in fluid communication with the chambers 300A and 300B.

FIG 3C illustrates a casing 300 configured to accommodate a multi-valve arrangement. Therefore, the walls 303 and 305 are machined out from the casing 300 thereby creating chambers 300E, 300F, and 300G in the casing 300. The chambers 300E, 300F, and 300G each accommodate a valve of the multi-valve arrangement therein for controlling the load points during operation of a steam turbine in which the casing 300 is to be used. A first valve and a third valve of the multi-valve arrangement are inserted into the casing 300 through holes 306 so as to be in fluid communication with the chambers 300E and 300F respectively. A hole 302 is machined from the casing 300 so as to provide fluid communication between a second valve of the multi-valve arrangement and the chamber 300G.

FIG 4 illustrates a sectional elevation view of the casing 300 shown in FIG 3B accommodating a single valve arrangement 400, according to an embodiment of the present invention. The casing

300 post machining has chambers 300A, 300B, 300C, and 300D. The hand valves 401 of the single valve arrangement 400 are each in fluid communication with the space defined by inner walls of the chambers 300A, 300B, and 300C respectively. Similarly, a governing valve (not shown) is in fluid communication with the space defined by inner walls of the chamber 300D.

FIG 5 illustrates a sectional elevation view of the casing 300 shown in FIG 3C accommodating a multi-valve arrangement 500, according to an embodiment of the present invention. The casing 300 post machining has chambers 300E, 300F, and 300G. The valves 501 of the multi-valve arrangement 500 are each in fluid communication with the space defined by inner walls of the chambers 300E, 300F, and 300G respectively.

FIG 6A-6E illustrate various steam inlet flow arrangements achieved using the casing 300 shown in FIGS 3A-3C. FIGS 6A-6D illustrate the casing 300 machined to suit a single valve arrangement 400 shown in FIG 4.

As shown in FIG 6A, the casing 300 allows entry of the steam from bottom right side 300J of the casing 300 allowing about 65% of the steam in the chamber 300D, 10% of the steam in each of the chambers 300A and 300B shown in FIG 3B, and 15% of the steam in the chamber 300C shown in FIG 3B upon operation of the hand valves 401 shown in FIG 4.

As shown in FIG 6B, the casing 300 allows entry of the steam from top right side 300I of the casing 300 allowing about 65% of the steam in the chamber 300D, 10% of the steam in each of the

chambers 300A and 300B, and 15% of the steam in the chamber 300C upon operation of the hand valves 401.

As shown in FIG 6C, the casing 300 is machined so as to allow entry of the steam from bottom right side 300J of the casing 300 thereby, allowing 100% steam to enter into the chamber 300D further being split into about 50% in each of the two halves within the chamber 300D i.e. upper half and lower half. Out of which, 10% of the steam enters the chamber 300B from the chamber 300C which is in communication with the chamber 300D through hand-valve 401. Also, 10% of the steam enters the chamber 300A upon operation of the hand valves 401. In this arrangement, one or more machineable elements, such as the machineable walls 304 and 305, of the casing 300 between the chambers 300D and 300C are machined to allow the chambers 300D and 300C to be in fluid communication with one another. Advantageously, for this embodiment of the casing 300 shown in FIG 6C, the single valve arrangement 400 works with three chambers 300A, 300B, and the chamber formed by combining the chambers 300C and 300D.

As shown in FIG 6D, the casing 300 is machined so as to allow entry of the steam from top right side 300I of the casing 300 thereby, allowing 40% of the steam to enter into the chamber 300D, 10% of the steam into the chamber 300A, 10% of the steam into the chamber 300B, and 40% of the steam into chamber 300C upon operation of the hand valves 401. In this arrangement, one or more machineable elements of the casing 300 between the chambers 300D and 300C are machined so as to allow approximately equal area within the chambers 300C and 300D.

FIGS 6E illustrates the casing 300 machined to suit a multi-valve arrangement 500 shown in FIG 5. As shown in FIG 6E, the casing 300 is machined so as to allow entry of the steam from top right side 300I of the casing 300 allowing 40% of the steam to flow into the chamber 300F, 20% of the steam to flow into the chamber 300G and 40% of the steam to flow into the chamber 300E upon operation of the valves 501.

The casing 300 shown in FIGS 6A-6E can be machined to accept the steam flow entry thorough the top left side 300H of the casing 300 for both single valve arrangement 400 as well as multi-valve arrangement 500.

The foregoing examples have been provided merely for the purpose of explanation and are in no way to be construed as limiting of the present invention disclosed herein. While the invention has been described with reference to various embodiments, it is understood that the words, which have been used herein, are words of description and illustration, rather than words of limitation. Further, although the invention has been described herein with reference to particular means, materials, and embodiments, the invention is not intended to be limited to the particulars disclosed herein; rather, the invention extends to all functionally equivalent structures, methods and uses, such as are within the scope of the appended claims.

Claims

1. A casing (300) for an inlet section of a steam turbine, the casing (300) comprising and characterized by:

- a plurality of chambers (C1-C5) inside the casing (300) capable of controlling a fluid flowing through the steam turbine in communication with a valve arrangement (400, 500); and
- machineable elements (301, 302, 303, 304, 305) configured to enable accommodation of one or more variants of valve arrangements (400, 500) in the casing (300), wherein the machineable elements (301, 302, 303, 304, 305) when selectively machined from the casing (300) decrease the chambers (C1-C5) there-within.

2. The casing (300) according to the claim 1, wherein the plurality of chambers (C1-C5) comprise at least five chambers (C1-C5).

3. The casing (300) according to the claim 1, wherein the valve arrangement (400, 500) comprises one of a single valve arrangement (400) and a multi-valve arrangement (500).

4. The casing (300) according to the claim 3, wherein accommodating a single valve arrangement (400) requires machining of the machineable elements (301, 302, 303, 304, 305) so as to form four chambers (300A-300D).

5. The casing (300) according to the claim 3, wherein accommodating a multi-valve arrangement (500) requires machining of the machineable elements (301, 302, 303, 304, 305) so as to form three chambers (300F-300E).

6. The casing (300) according to any one the previous claims, wherein one or more physical dimensions of the machineable elements (301, 302, 303, 304, 305) are configured based on one or more fluid dynamics parameters associated with a fluid used in the steam turbine, wherein the fluid dynamics parameters comprise one or more of a pressure of the fluid, a velocity of the fluid, a temperature of the fluid, and a volumetric flow of the fluid.

7. The casing (300) according to any one of the previous claims, wherein the machineable elements (306A) are configured to enable fluid inflow from each of opposing sides (300H, 300I) of the casing (300), wherein the machineable elements (306A) when selectively machined from the casing (300) open the sides (300H, 300I) of the casing (300).

FIG 1

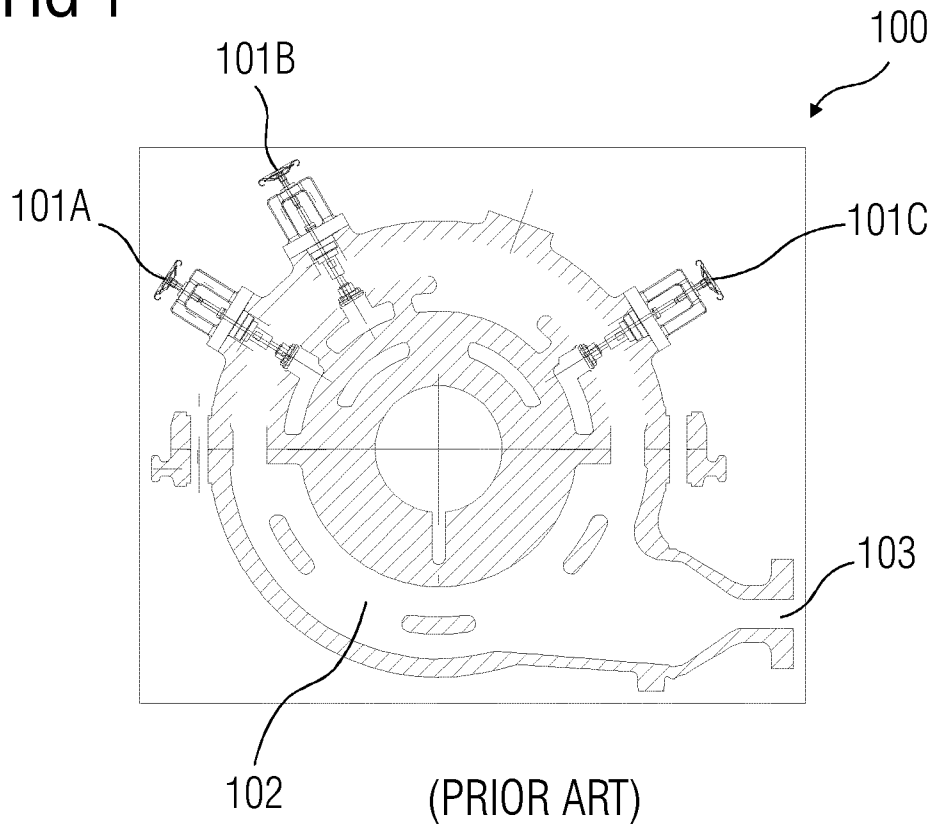
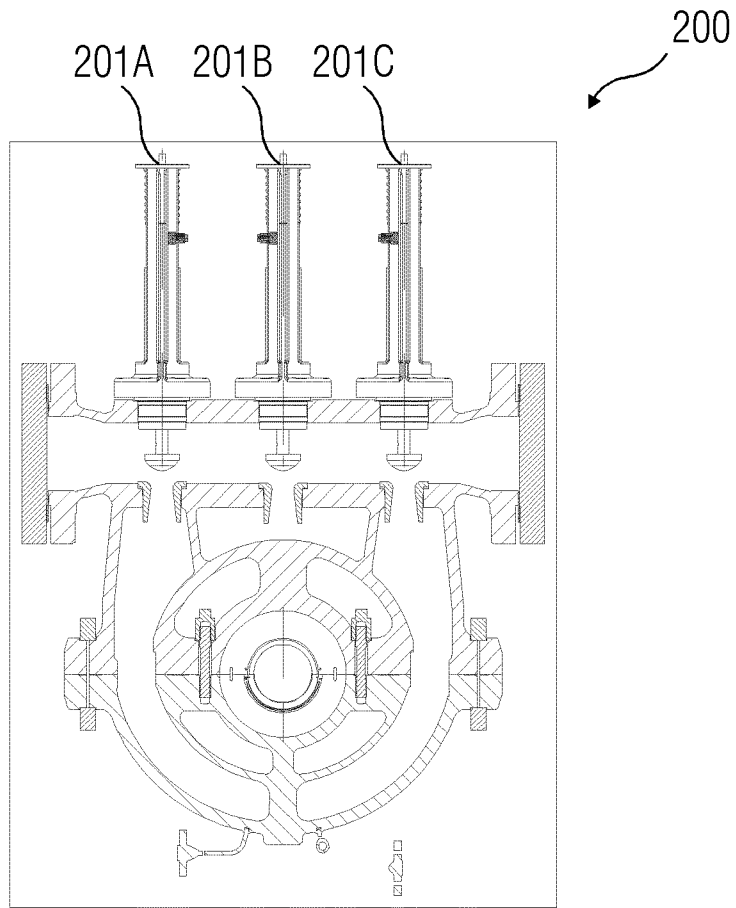

FIG 2



(PRIOR ART)

FIG 3A

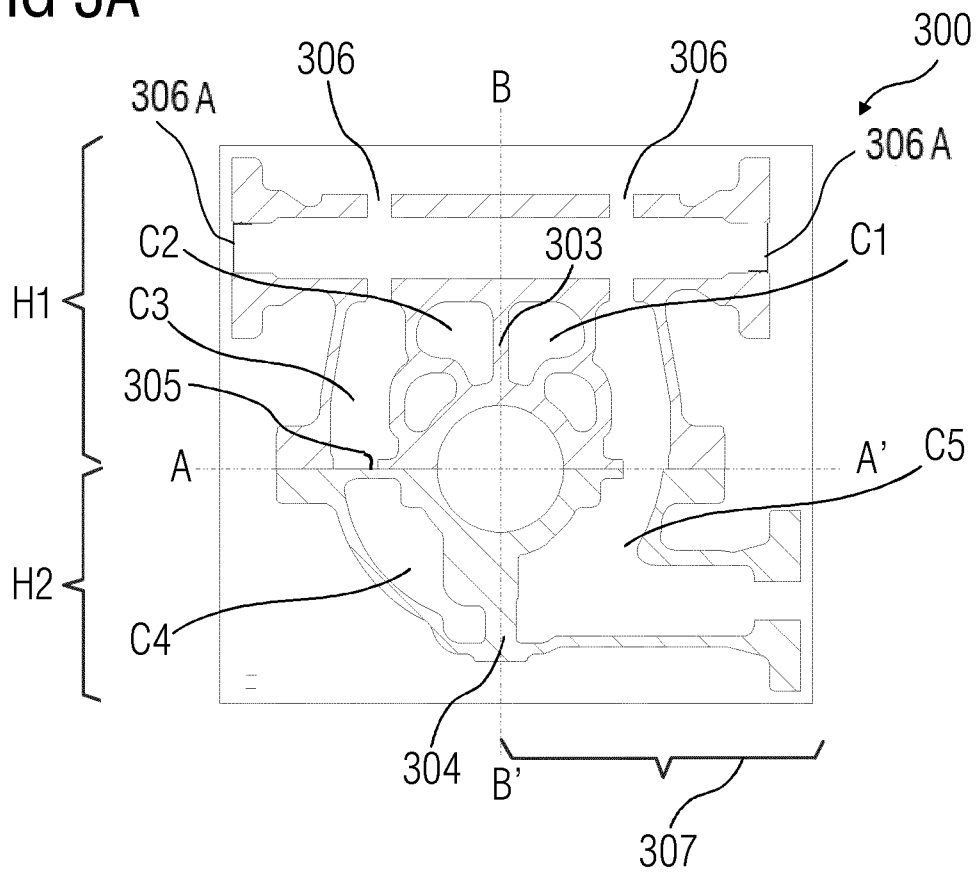

FIG 3B

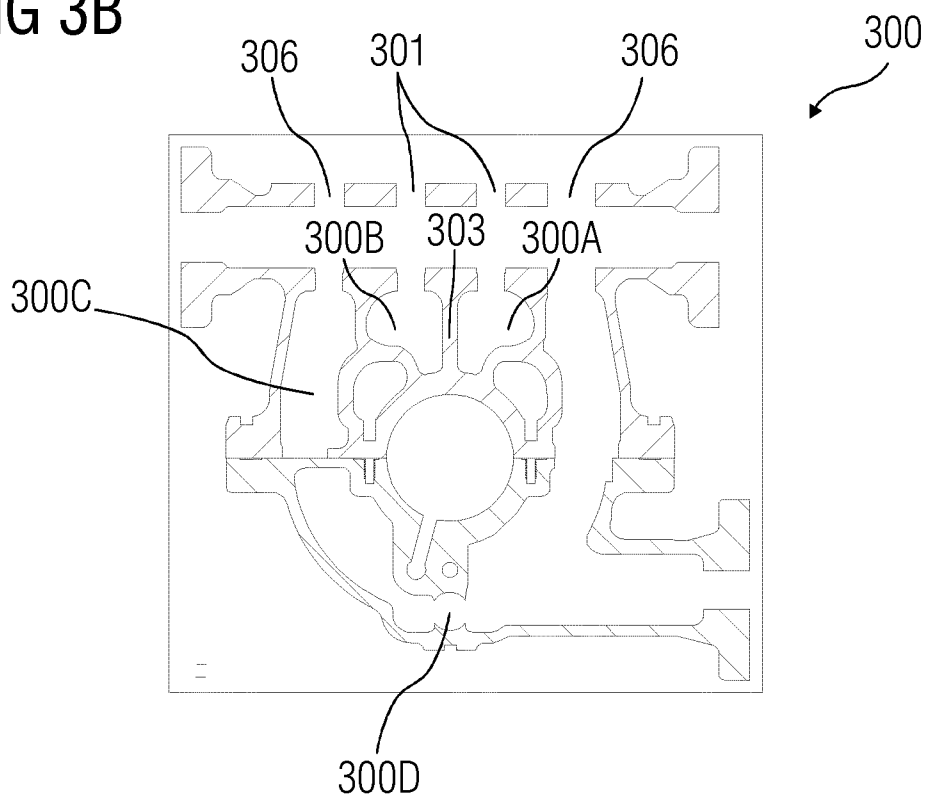

FIG 3C

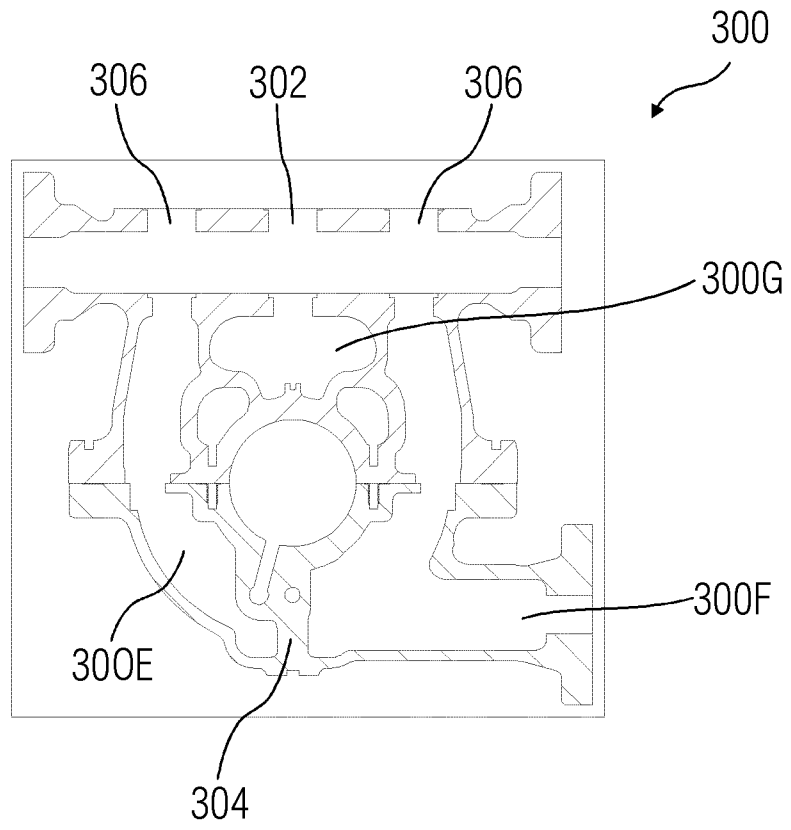

FIG 4

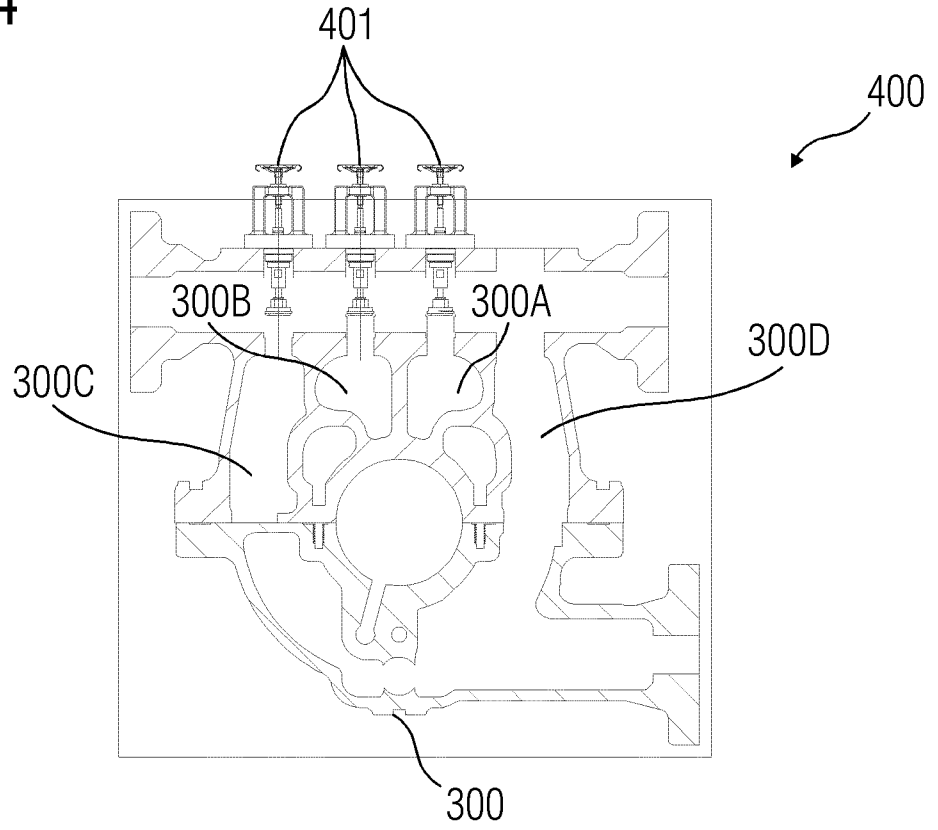

FIG 5

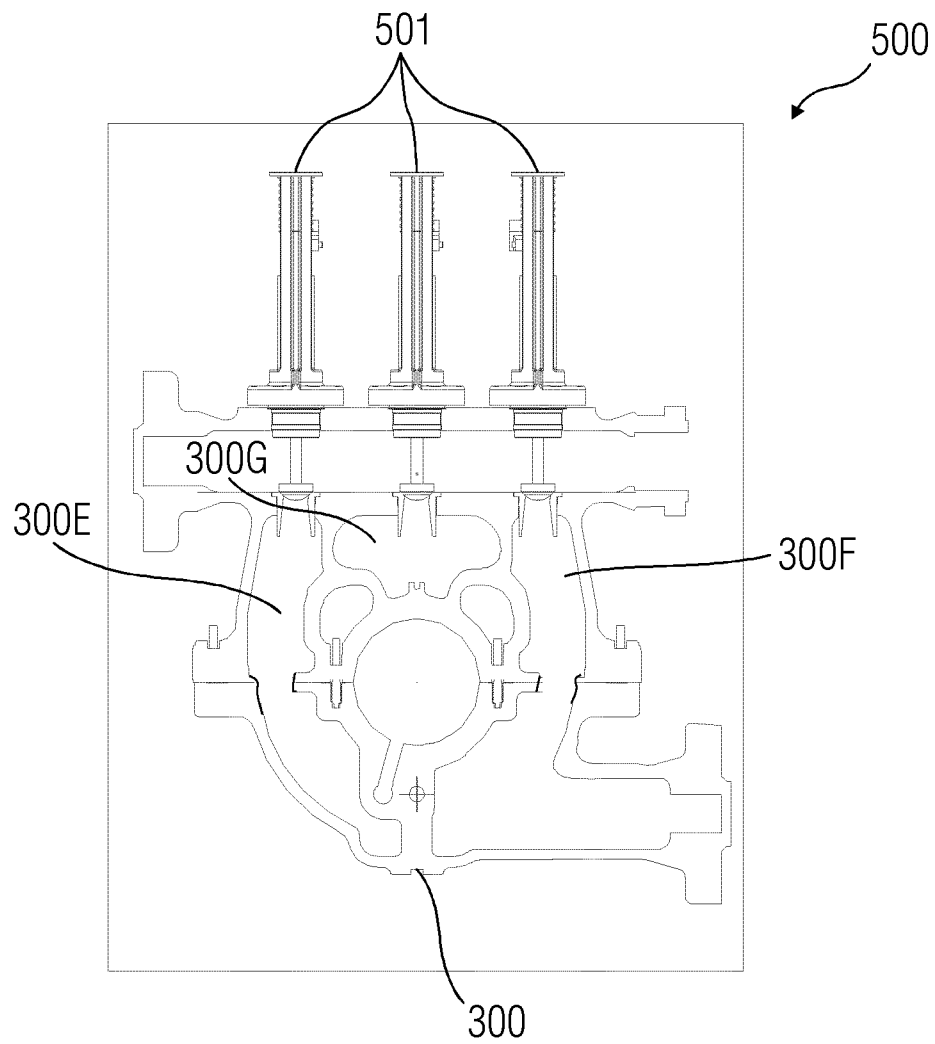

FIG 6A

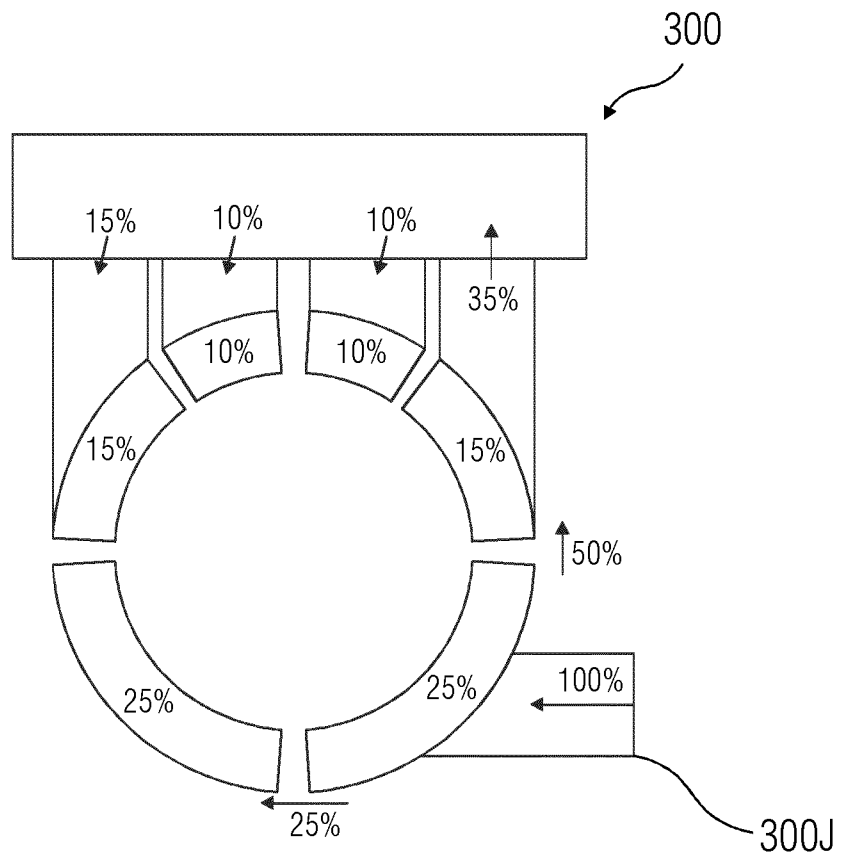

FIG 6B

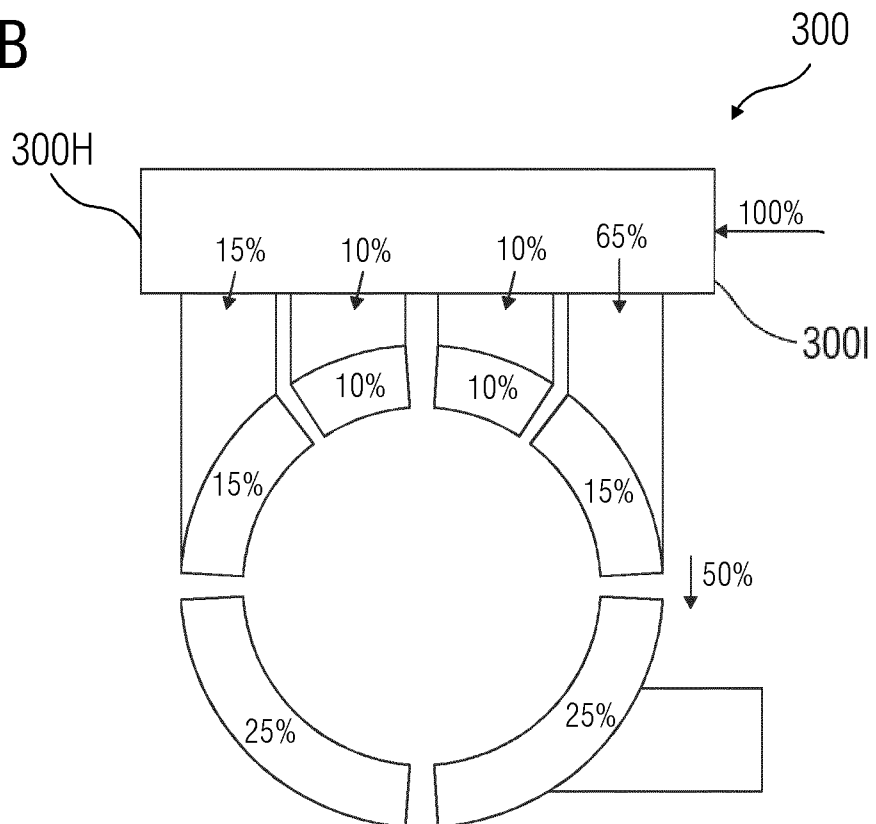

FIG 6C

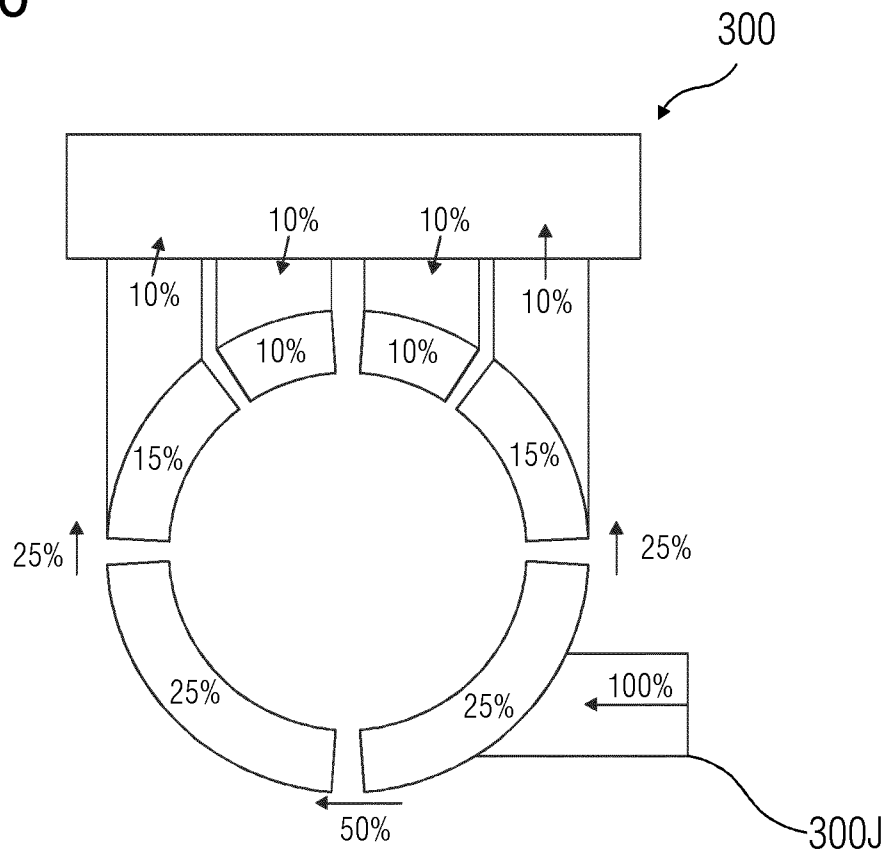

FIG 6D

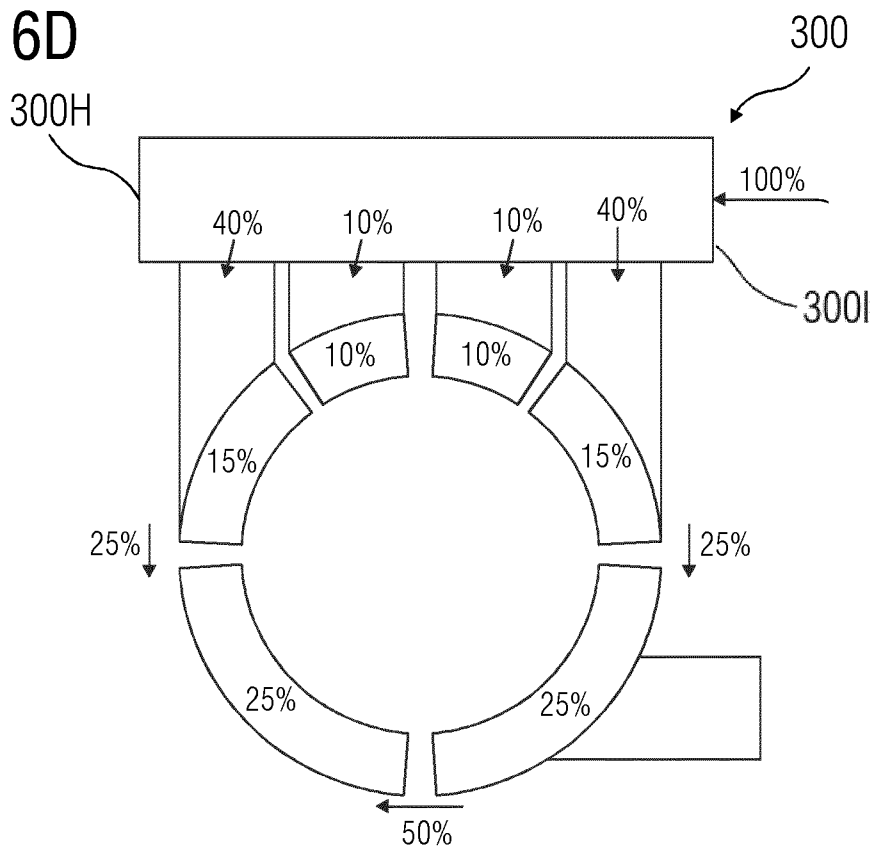
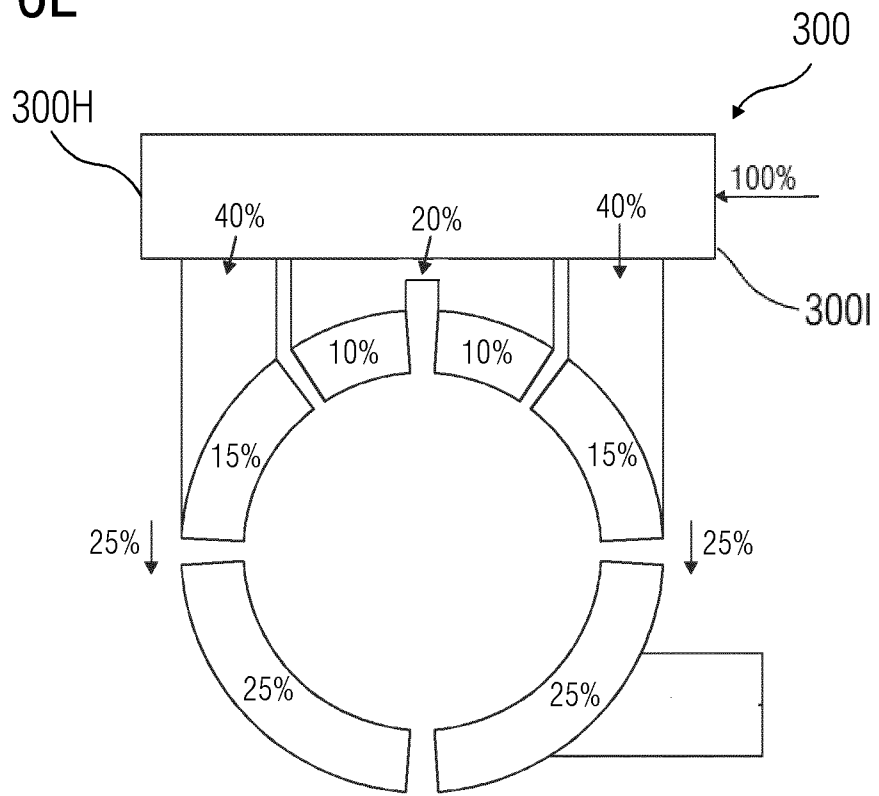

FIG 6E



INTERNATIONAL SEARCH REPORT

International application No
PCT/EP2020/065020

A. CLASSIFICATION OF SUBJECT MATTER
 INV. F01D17/18 F01D25/24 F16K11/20 F16K27/02
 ADD.
 According to International Patent Classification (IPC) or to both national classification and IPC

B. FIELDS SEARCHED
 Minimum documentation searched (classification system followed by classification symbols)
 F01D F16K

Documentation searched other than minimum documentation to the extent that such documents are included in the fields searched

Electronic data base consulted during the international search (name of data base and, where practicable, search terms used)
 EPO-Internal, WPI Data

C. DOCUMENTS CONSIDERED TO BE RELEVANT

Category*	Citation of document, with indication, where appropriate, of the relevant passages	Relevant to claim No.
X	US 6 302 644 B1 (KUKALJ IVAN [CH] ET AL) 16 October 2001 (2001-10-16) column 1, line 5 - line 6 column 1, line 63 - column 2, line 27 column 2, line 51 - line 57 column 3, line 4 - line 9 figures 1-2	1-7
A	US 2015/252681 A1 (KOTIAN DAYANANDA THUKRA [IN] ET AL) 10 September 2015 (2015-09-10) paragraph [0001] paragraph [0019] - paragraph [0021] paragraph [0025] - paragraph [0027] paragraph [0040] figure 1	1-7

Further documents are listed in the continuation of Box C.

See patent family annex.

* Special categories of cited documents :

- "A" document defining the general state of the art which is not considered to be of particular relevance
- "E" earlier application or patent but published on or after the international filing date
- "L" document which may throw doubts on priority claim(s) or which is cited to establish the publication date of another citation or other special reason (as specified)
- "O" document referring to an oral disclosure, use, exhibition or other means
- "P" document published prior to the international filing date but later than the priority date claimed

- "T" later document published after the international filing date or priority date and not in conflict with the application but cited to understand the principle or theory underlying the invention
- "X" document of particular relevance; the claimed invention cannot be considered novel or cannot be considered to involve an inventive step when the document is taken alone
- "Y" document of particular relevance; the claimed invention cannot be considered to involve an inventive step when the document is combined with one or more other such documents, such combination being obvious to a person skilled in the art
- "&" document member of the same patent family

Date of the actual completion of the international search 13 August 2020	Date of mailing of the international search report 25/08/2020
--	---

Name and mailing address of the ISA/ European Patent Office, P.B. 5818 Patentlaan 2 NL - 2280 HV Rijswijk Tel. (+31-70) 340-2040, Fax: (+31-70) 340-3016	Authorized officer Nicolai, Sébastien
--	---

INTERNATIONAL SEARCH REPORT

International application No
PCT/EP2020/065020

C(Continuation). DOCUMENTS CONSIDERED TO BE RELEVANT		
Category*	Citation of document, with indication, where appropriate, of the relevant passages	Relevant to claim No.
A	DE 44 25 352 A1 (ABB PATENT GMBH [DE]) 25 January 1996 (1996-01-25) column 1, line 3 - line 4 column 1, line 47 - line 67 column 3, line 65 - column 4, line 13 claims 1-2 figures 1-4	1-7
A	----- DE 197 08 273 C1 (SIEMENS AG [DE]) 30 April 1998 (1998-04-30) column 1, line 3 - line 8 column 2, line 44 - column 3, line 11 figures 1-2, 3a-3c -----	1-7

INTERNATIONAL SEARCH REPORT

Information on patent family members

International application No PCT/EP2020/065020

Patent document cited in search report	Publication date	Patent family member(s)	Publication date
US 6302644	B1	16-10-2001	EP 1026369 A1 09-08-2000 JP 2000227007 A 15-08-2000 US 6302644 B1 16-10-2001

US 2015252681	A1	10-09-2015	CN 205101051 U 23-03-2016 DE 102015103044 A1 10-09-2015 JP 2015169208 A 28-09-2015 US 2015252681 A1 10-09-2015

DE 4425352	A1	25-01-1996	NONE

DE 19708273	C1	30-04-1998	DE 19708273 C1 30-04-1998 WO 9838413 A1 03-09-1998
