



(19) **United States**

(12) **Patent Application Publication**  
**Appelman et al.**

(10) **Pub. No.: US 2013/0080551 A1**

(43) **Pub. Date: Mar. 28, 2013**

(54) **PASSIVE PERSONALIZATION OF BUDDY LISTS**

**Publication Classification**

(76) Inventors: **Barry Appelman**, Great Falls, VA (US);  
**James A. Roskind**, Redwood City, CA (US)

(51) **Int. Cl.**  
*H04L 12/58* (2006.01)  
(52) **U.S. Cl.**  
CPC ..... *H04L 51/04* (2013.01)  
USPC ..... *709/206*

(21) Appl. No.: **13/618,683**

(22) Filed: **Sep. 14, 2012**

(57) **ABSTRACT**

**Related U.S. Application Data**

(63) Continuation of application No. 12/336,880, filed on Dec. 17, 2008, which is a continuation of application No. 10/184,002, filed on Jun. 28, 2002, now Pat. No. 7,512,652, which is a continuation-in-part of application No. 10/134,437, filed on Apr. 30, 2002, now Pat. No. 7,765,484.

(60) Provisional application No. 60/325,084, filed on Sep. 28, 2001.

Personalizing communications for a first communication platform includes accessing status information for communication sessions by a communication identity that leverage a first communication platform other than an instant messaging platform. A participant list associated with the communication identity and the first communication platform is passively configured to persistently reflect a list of participant identities from communication sessions in which the communication identity recently participated using the communication platform.

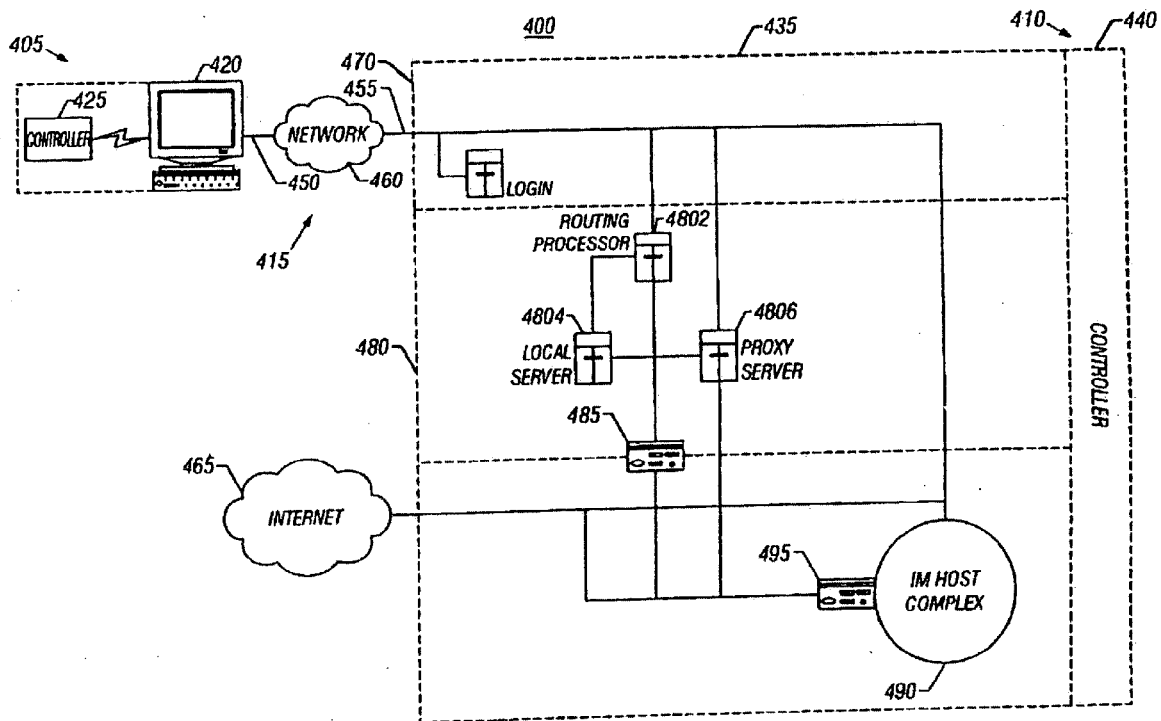

100

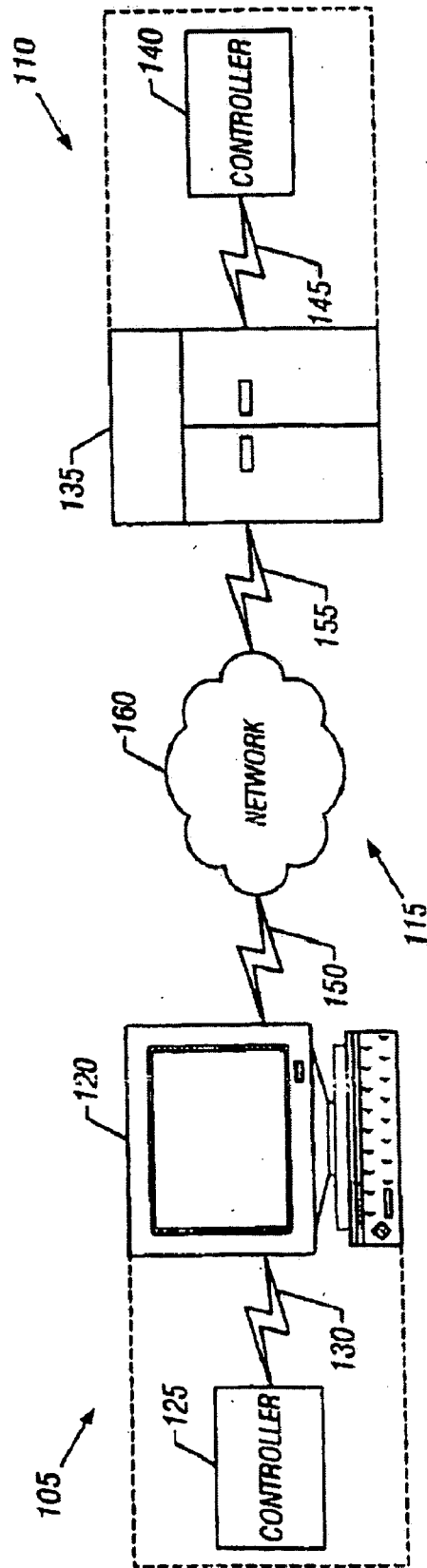

FIG. 1

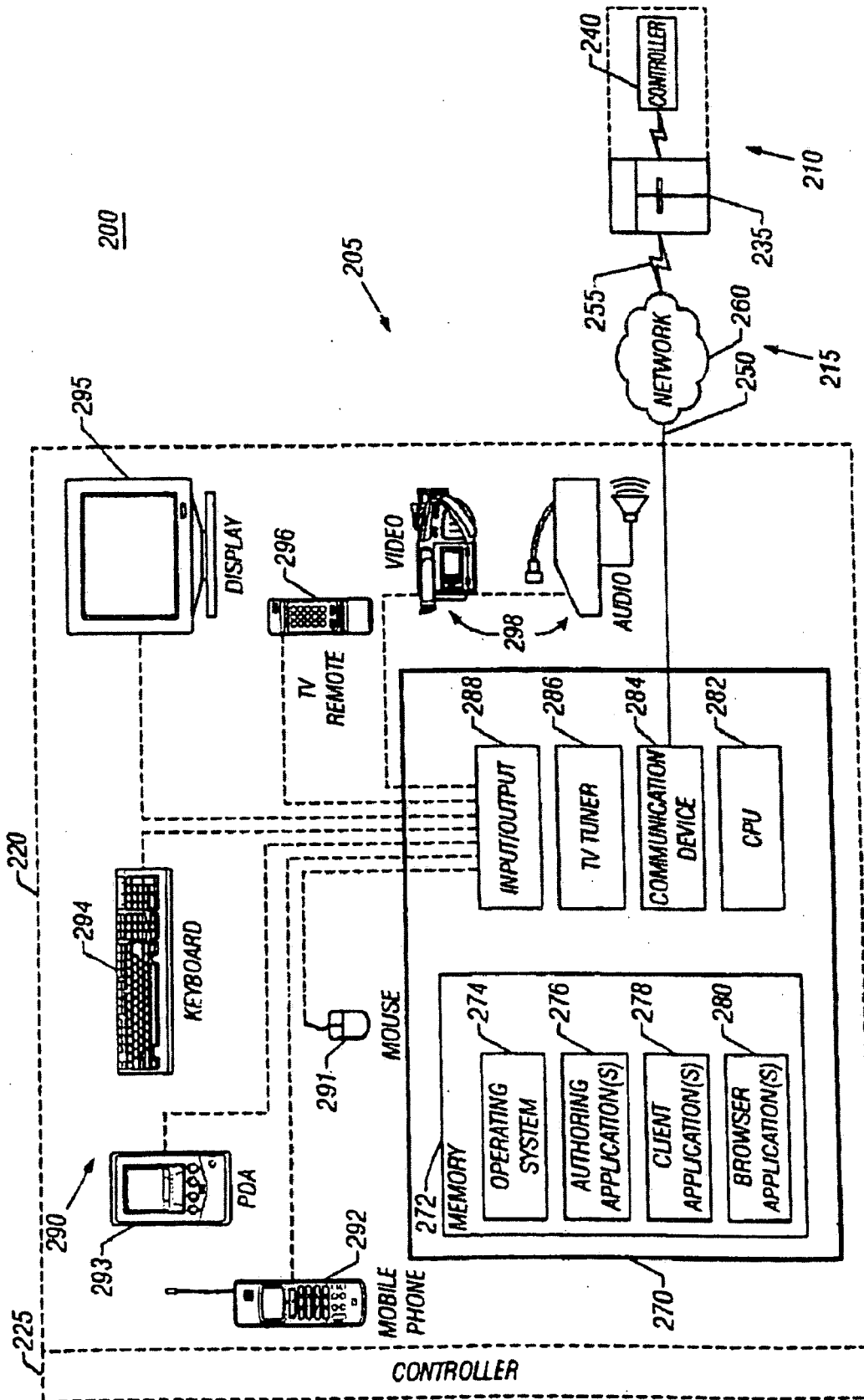

FIG. 2

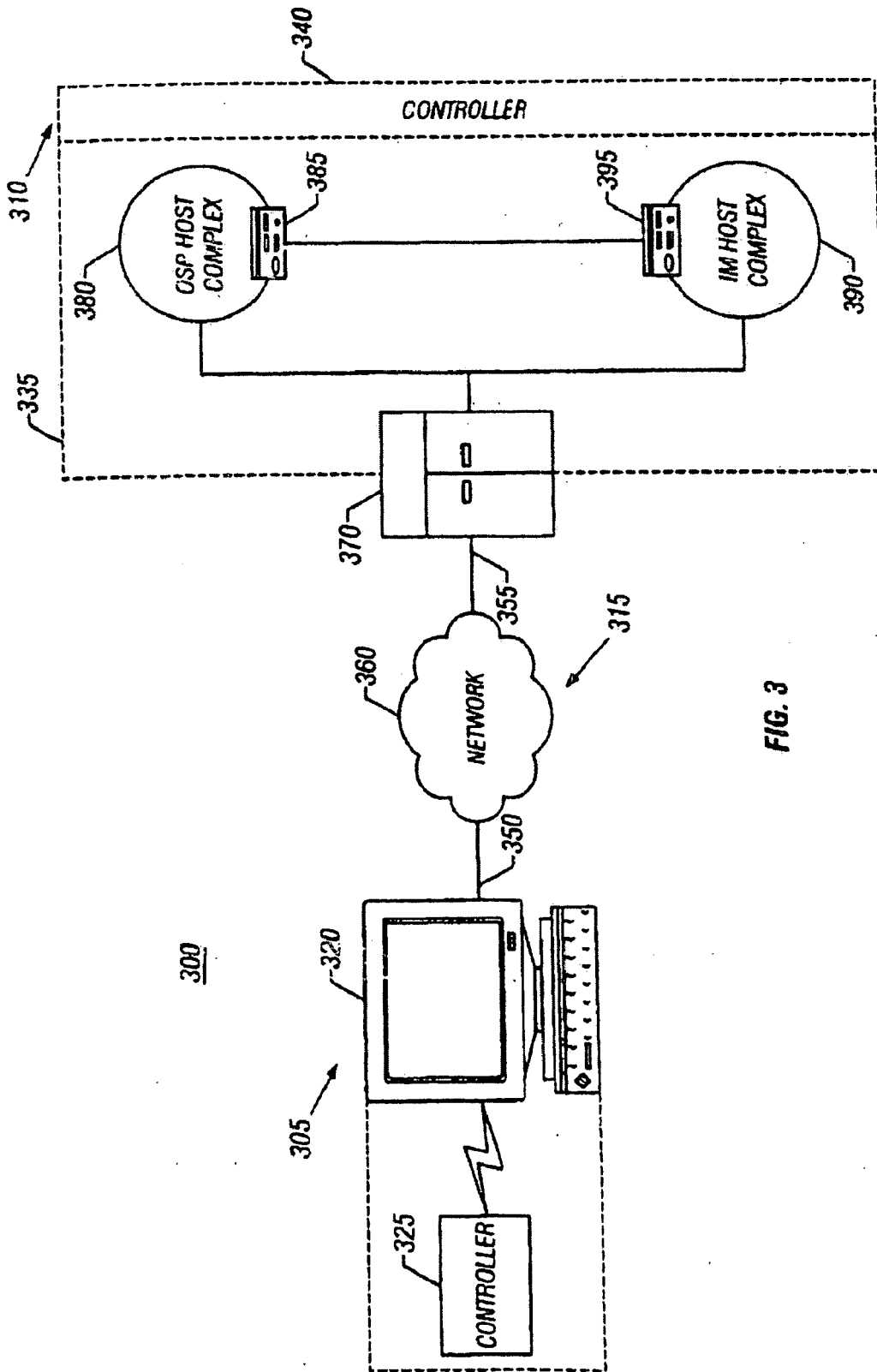

FIG. 3

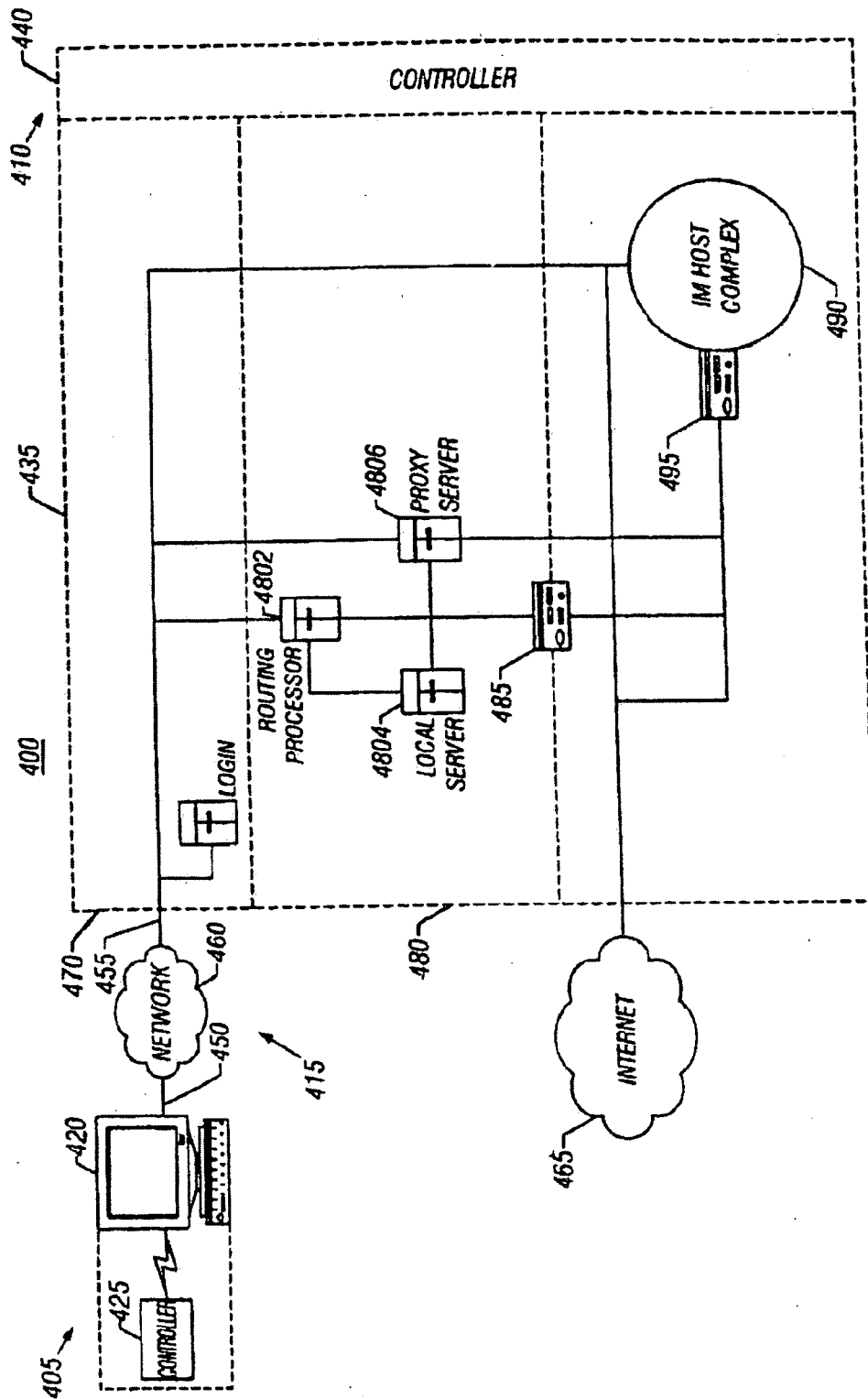

FIG. 4

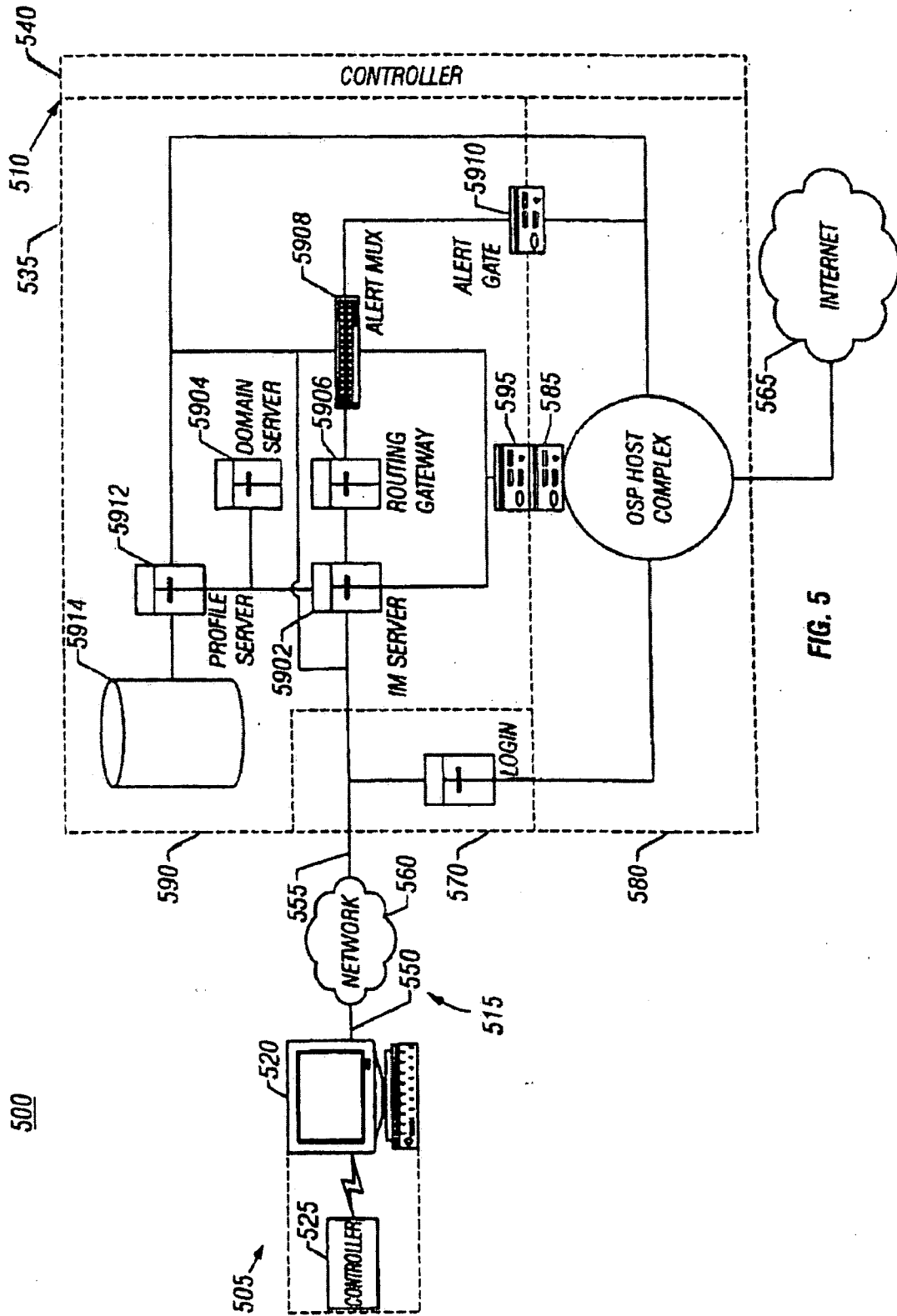

FIG. 5

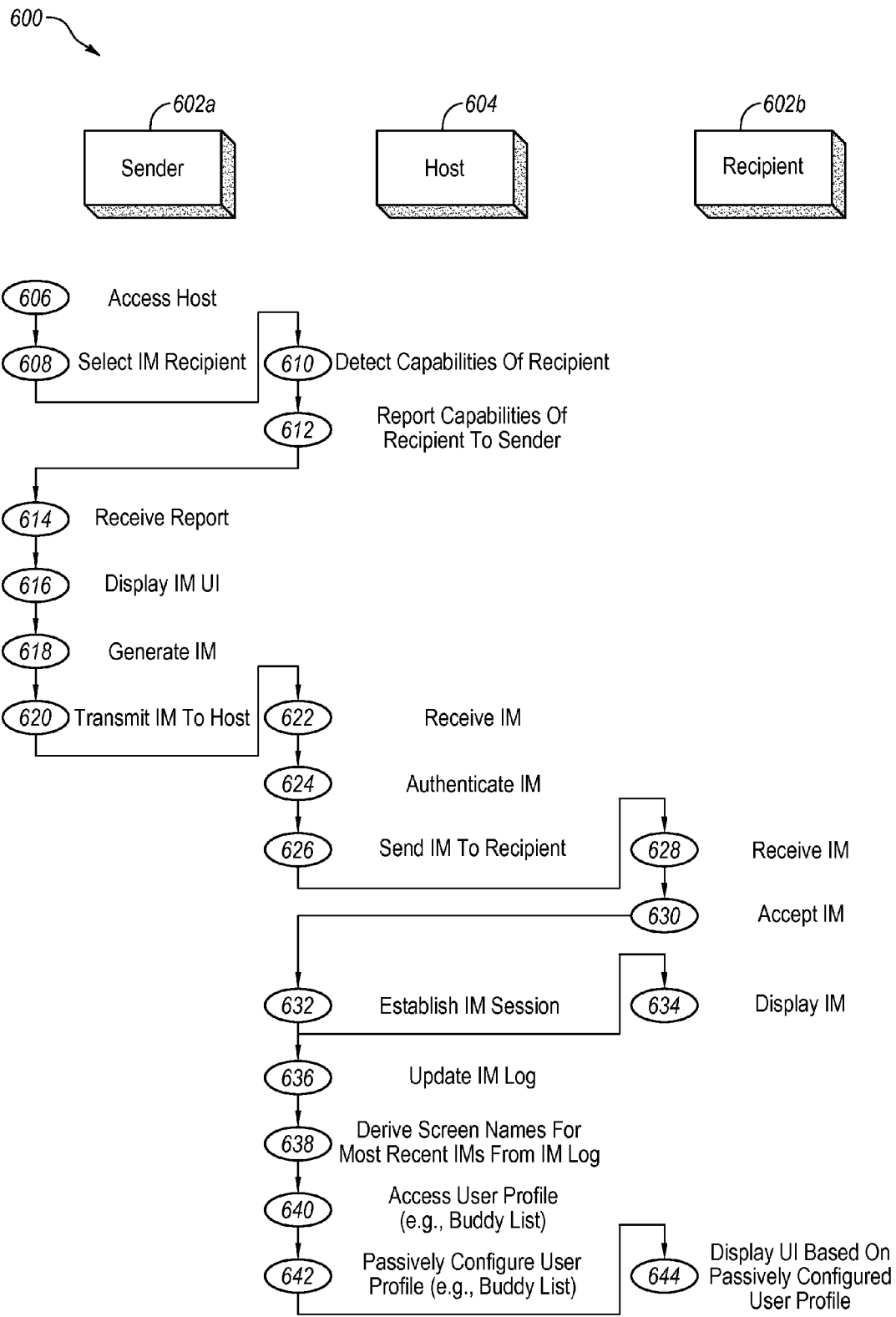

Fig. 6

700

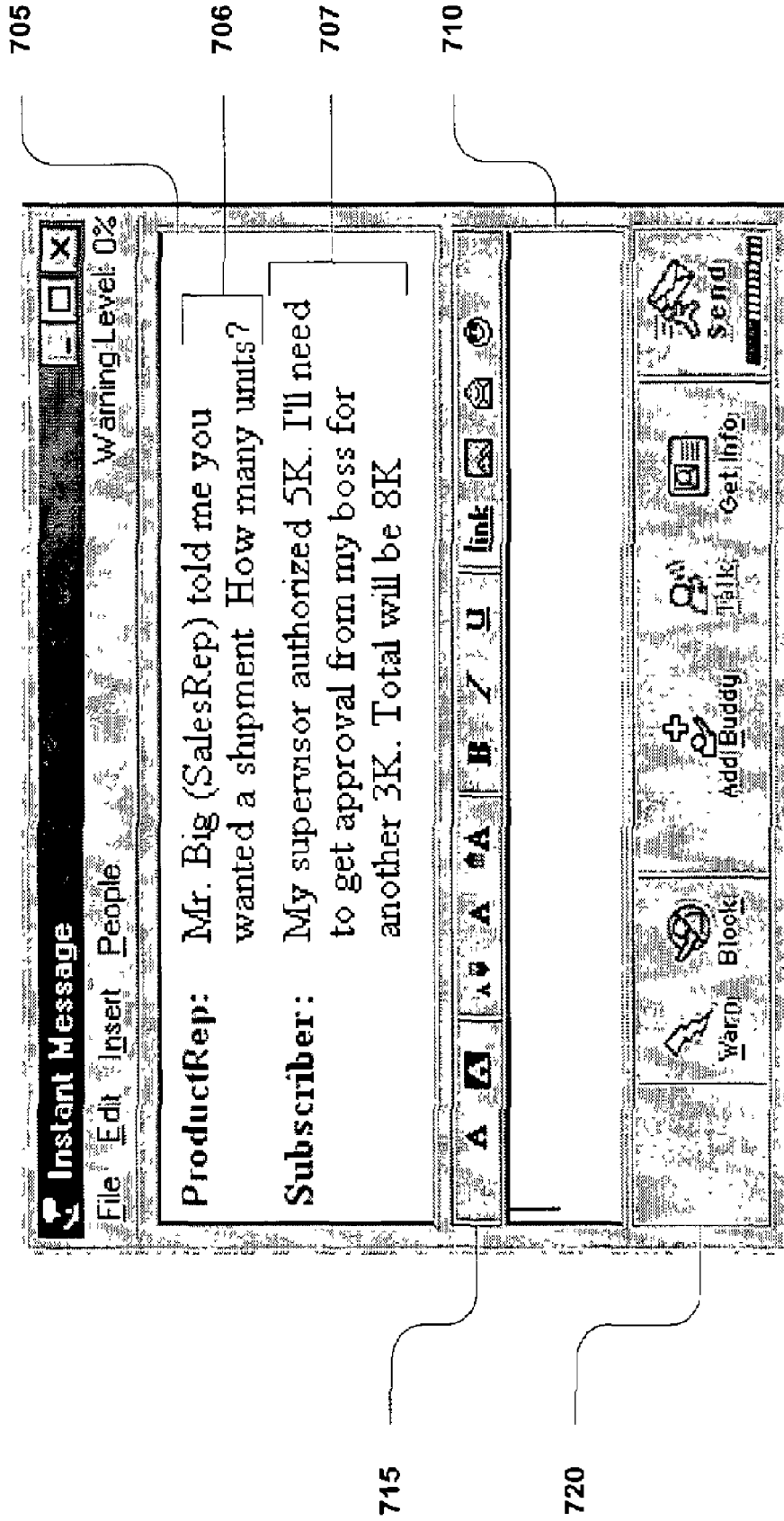

Fig. 7



800

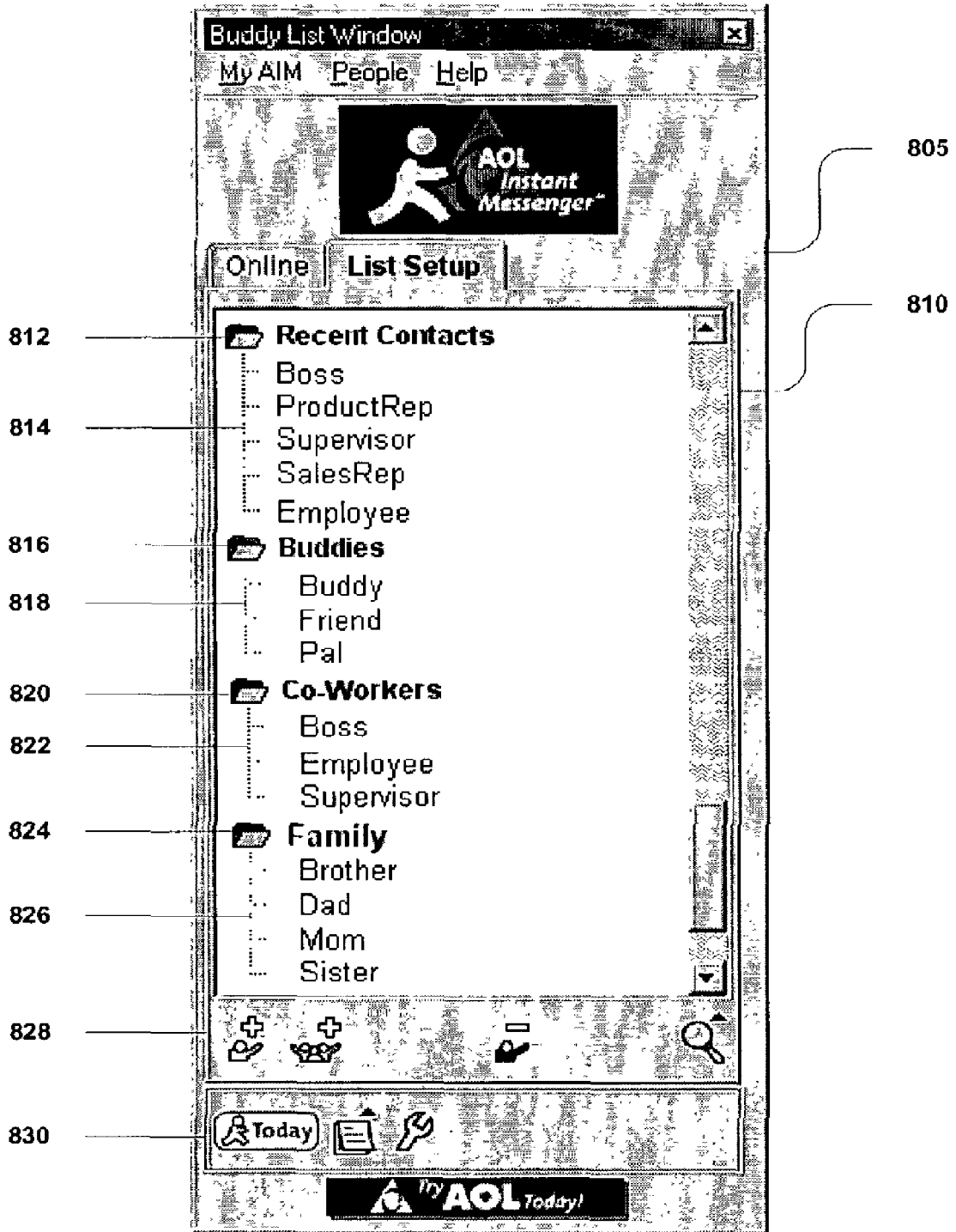

Fig. 8

900

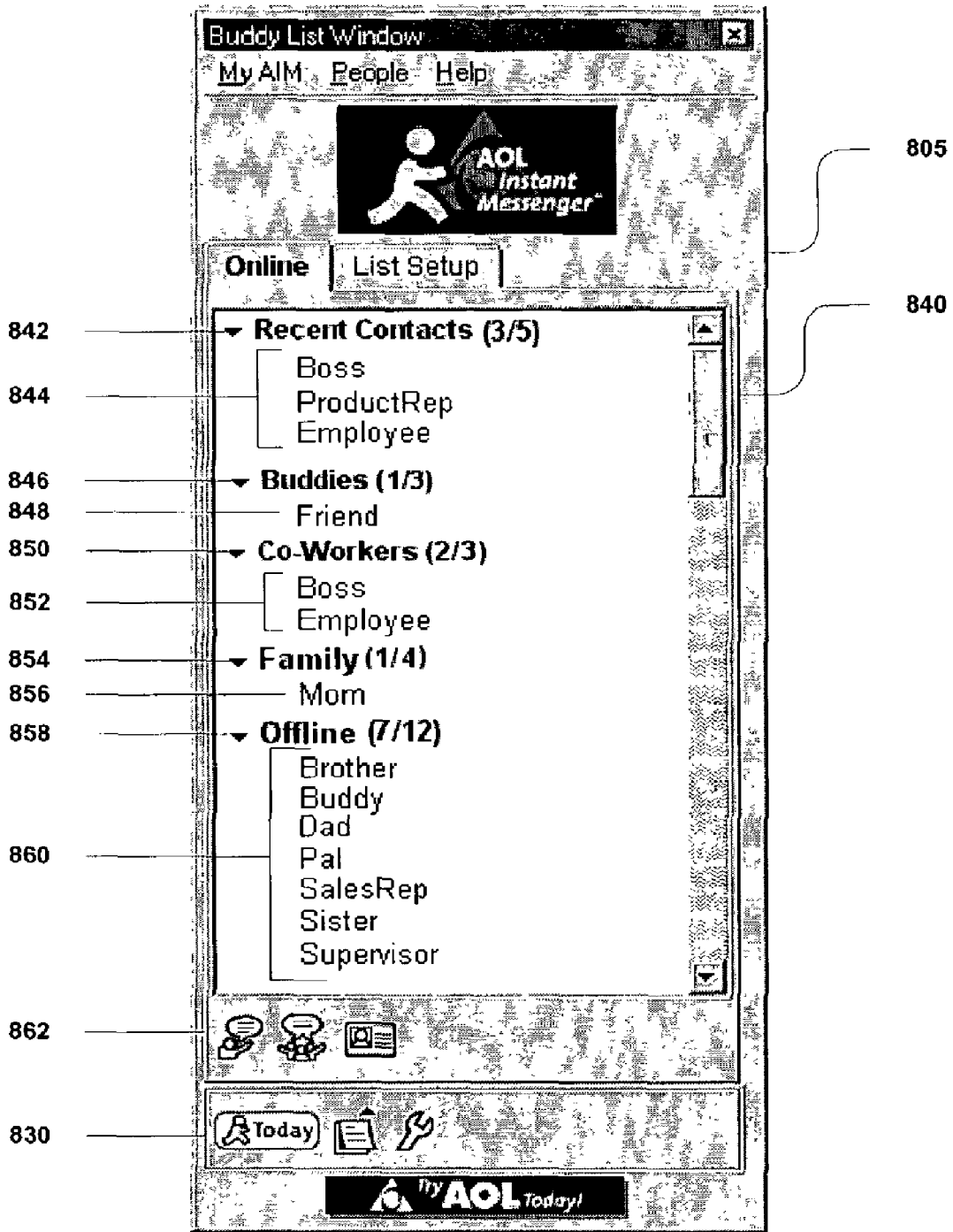

Fig. 9

1000

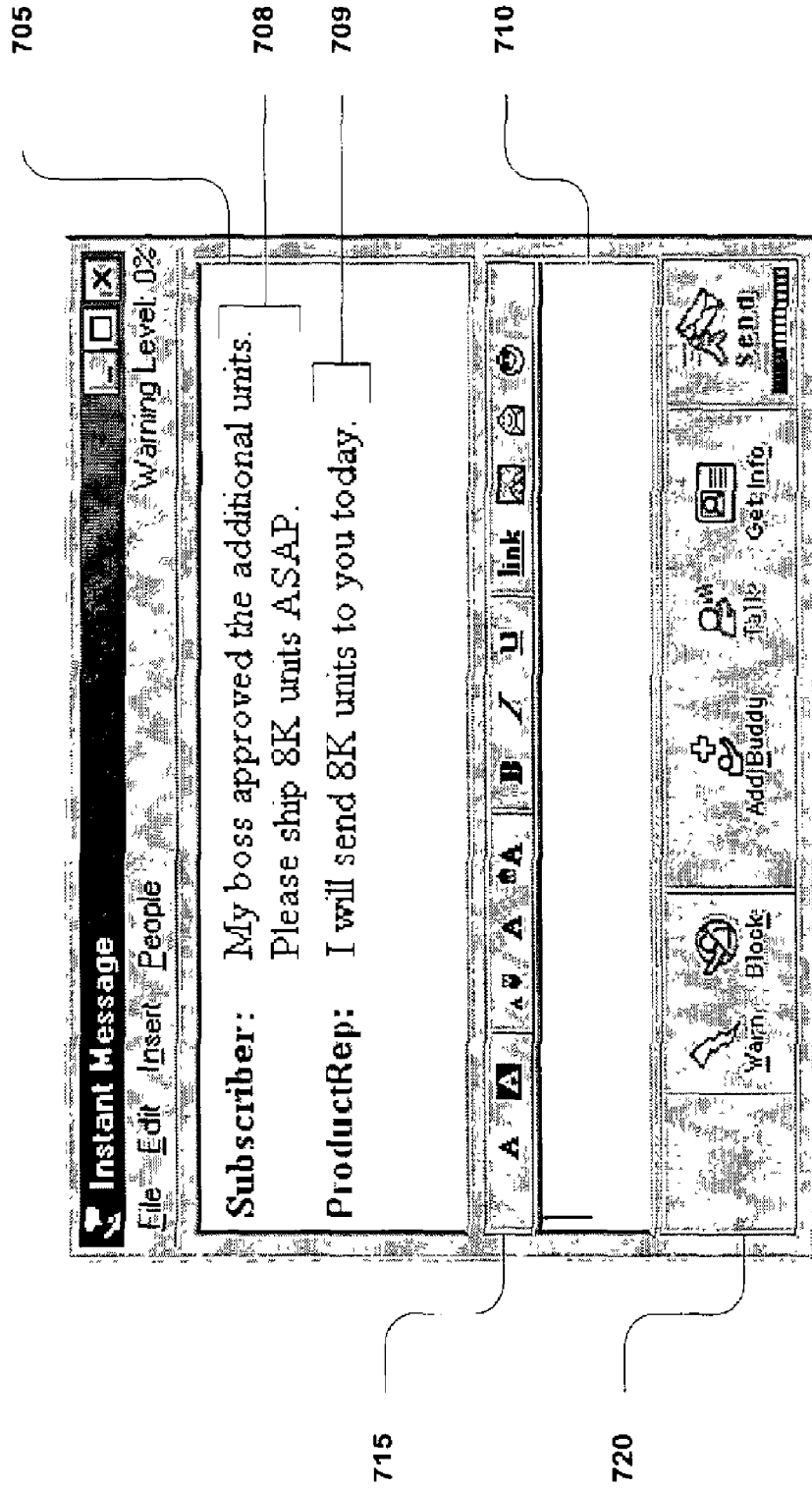
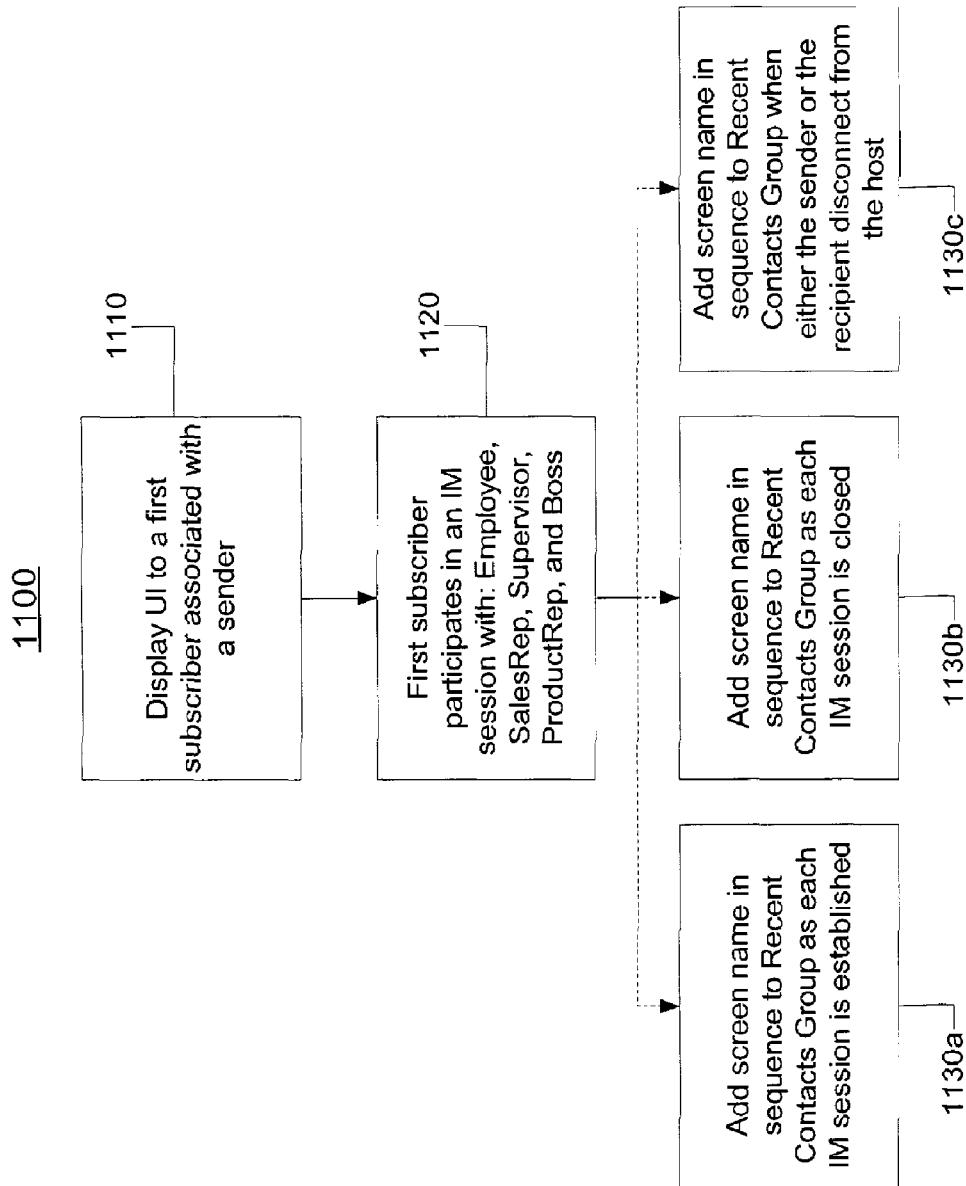

Fig. 10



**Fig. 11**

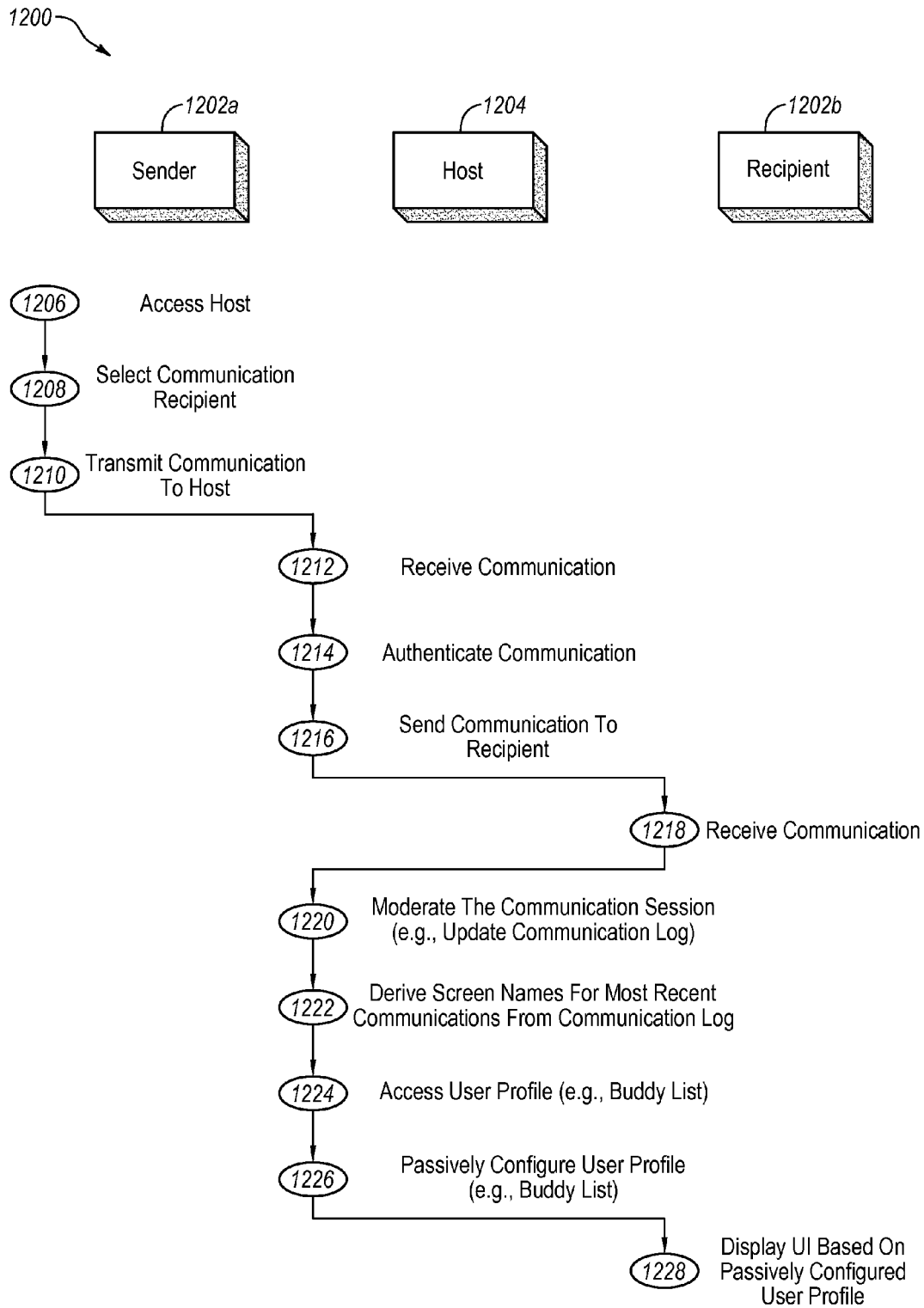

Fig. 12

1300

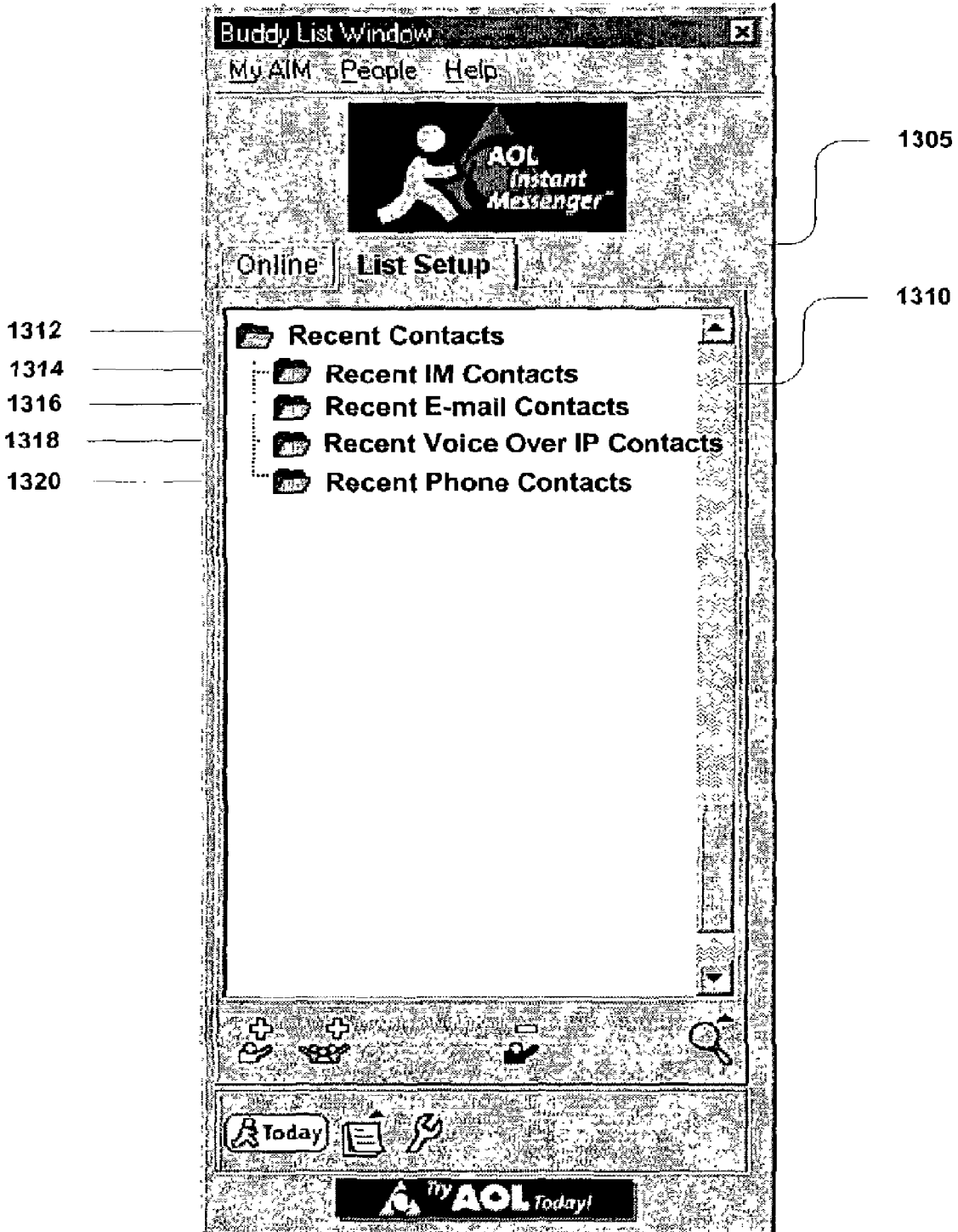

Fig. 13A

1350

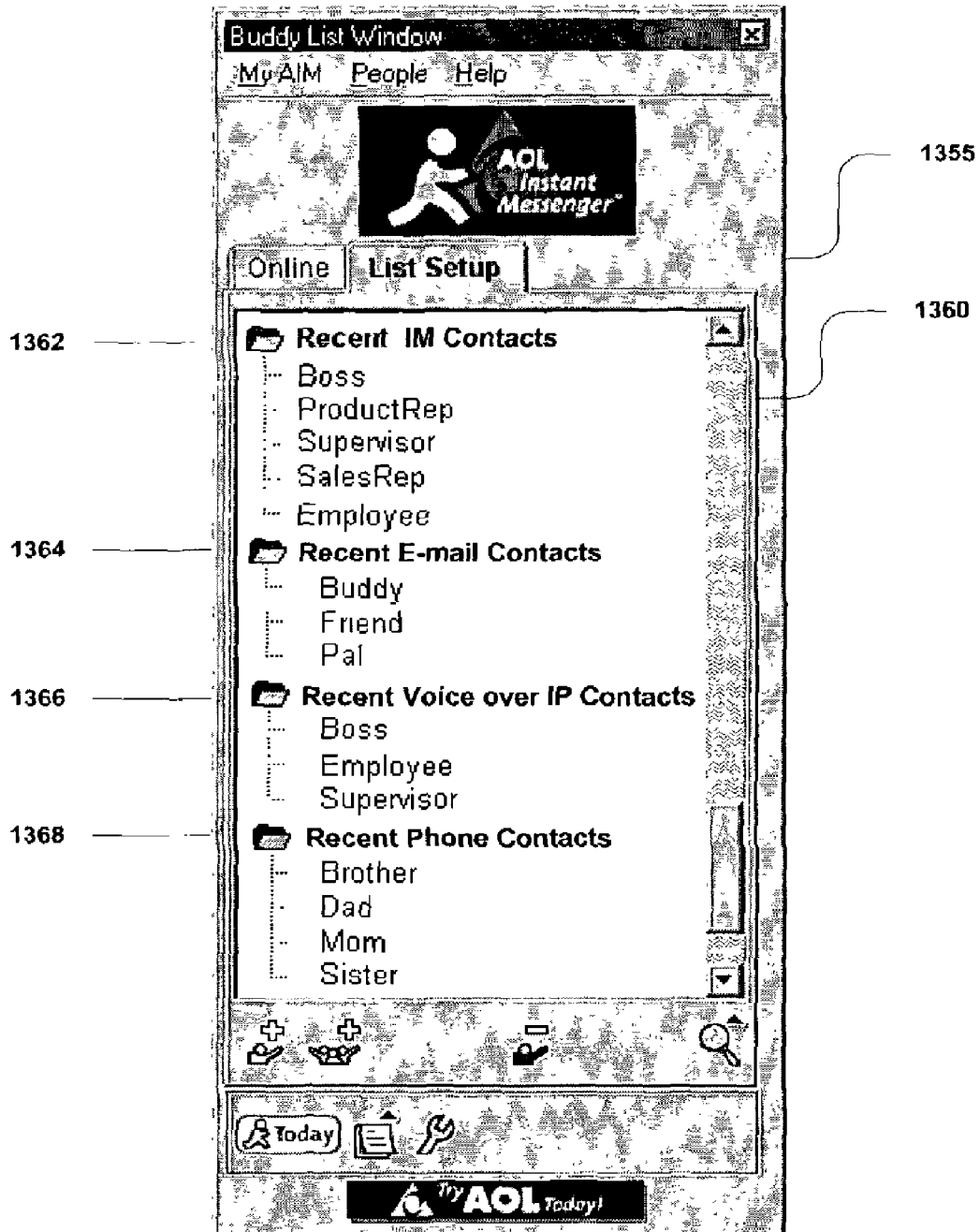

Fig. 13B

1400

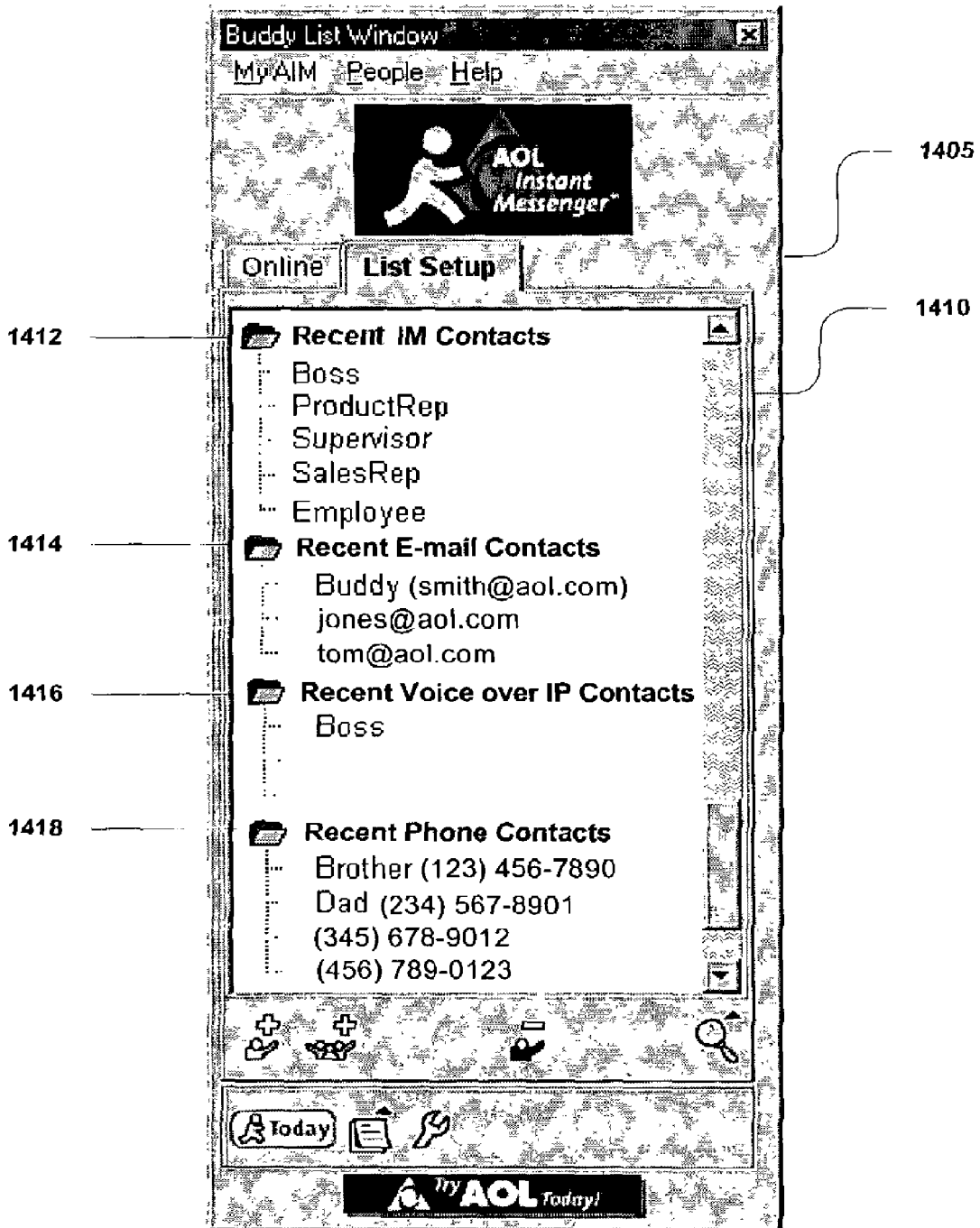

Fig. 14



## PASSIVE PERSONALIZATION OF BUDDY LISTS

### CROSS REFERENCE TO RELATED APPLICATIONS

**[0001]** The present application is a continuation of U.S. application Ser. No. 12/336,880, filed Dec. 17, 2008, which is a continuation of U.S. application Ser. No. 10/184,002, filed Jun. 28, 2002, which is now issued as U.S. Pat. No. 7,512,652, which is a continuation in part of U.S. application Ser. No. 10/134,437, filed Apr. 30, 2002, which is now issued as U.S. Pat. No. 7,765,484, which claims the benefit of and priority to U.S. provisional application No. 60/325,084, filed Sep. 28, 2001.

### TECHNICAL FIELD

**[0002]** The following description relates generally to passively personalizing a user interface, such as an instant messaging user interface.

### BACKGROUND

**[0003]** Online service providers offer new services and upgrade existing services to enhance their subscribers' online experience. Subscribers have on-demand access to news, weather, financial, sports, and entertainment services, and have the ability to transmit electronic messages and to participate in online discussion groups. For example, subscribers of online service providers such as America Online or CompuServe may view and retrieve proprietary or third party content on a wide variety of topics from servers located throughout the world.

**[0004]** One such service is instant messaging. Members of an instant messaging service can communicate virtually in real time with other instant messaging members. Members may manually create a list of screen names for other members, and may establish instant messaging sessions with those other members using a list of screen names, which also may be referred to as a buddy list.

### SUMMARY

**[0005]** In one general aspect, personalizing communications for a first communication platform, such as instant messaging, includes accessing status information for communication sessions by a communication identity that leverage a first communication platform other than an instant messaging platform. A participant list associated with the communication identity and the first communication platform is passively configured to persistently reflect a list of participant identities from communication sessions in which the communication identity recently participated using the communication platform.

**[0006]** Implementations may include one or more of the following features. For example, the participant list may be configured without action from the communication identity. The list of participant identities from communication in which the communication identity recently participated may be maintained persistently beyond logout of the communication identity. The participant identities may be maintained on the list after a communication session between the participant identity and the communication identity is terminated.

**[0007]** The first communication platform may include electronic mail platform, an electronic chat platform, a voice-over-IP telephony platform, and/or a telephony platform. An

electronic mail participant list, an electronic chat participant list, a voice-over-IP participant list, and/or a telephony participant list may be passively configured. The participant list associated with the communication identity and the communication platform may be passively configured. A buddy group may be passively configured.

**[0008]** The participant list may include contact information for at least one of the participant identities that may be used to enable a communication session with at least one participant identity using the first communication platform and/or a second communication platform. The second communication platform may include an instant message platform. In one implementation, the first communication platform may include one of an electronic mail platform, an electronic chat platform, a voice-over-IP telephony platform, and a telephony platform, and the second communication platform may include a different one of the electronic mail platform, the electronic chat platform, the voice-over-IP telephony platform, and the telephony platform.

**[0009]** In one implementation, the participant identities may be maintained on the list independent of a device or devices used for the communication sessions during which the list was created such that the participant list is accessible from one or more different devices. The participant list may be stored on a remote device accessible to one or more different devices.

**[0010]** In one implementation, a participant identity may be added to the participant list only when a communication session with the participant identity is closed. Additionally or alternatively, a participant identity may be added to the participant list only when a communication session with the participant identity is closed and the participant identity is not already included in the participant list. The participant identity may be listed as the most recently closed on the list.

**[0011]** In another implementation, participant identity may be added to the participant list when a communication session with the participant identity is established. Additionally or alternatively, a participant identity may be added to the participant list when a communication session with the participant identity is established and the participant identity is not already included in the participant list.

**[0012]** The participant list of communication sessions in which the communication identity recently participated may be limited to participant identities not otherwise included on any other list for the communication identity. The participant list may be configured to exclude participant identities from which a communication is received but not accepted. The participant list may include participant identities that are included on at least one other list for the communication identity.

**[0013]** The size of the participant list may be limited. A size of the participant list may be established based on a selection by the communication identity, and may be initially established based on a default value. The participant list may be sequenced using a least-recently-used methodology. Additionally or alternatively, the participant list may be sequenced using a first-in first-out methodology.

**[0014]** Participant identities may be arranged on the participant list such that a most recent participant identity is listed first. Participant identities may be arranged on the participant list such that a least-recently-used screen name is omitted whether or not the least recently used screen name was first-in on the list of participant identities.

**[0015]** The passively-configured participant list may be displayed. An online status may be displayed for each participant identity in the participant list.

**[0016]** A log associated with the communication identity may be updated. The log may include a chronological record of communication activity. In one implementation, the participant list may be based on the updated log. Updating the log may include deriving and recording a screen name of a participant identity. Updating the log also may include recording a time when a communication session is established.

**[0017]** These general and specific aspects may be implemented using a system, a method, or a computer program, or any combination of systems, methods, and computer programs.

**[0018]** Other features will be apparent from the description and drawings, and from the claims.

**[0019]** DESCRIPTION OF DRAWINGS

**[0020]** FIG. 1 is a block diagram of a communications system.

**[0021]** FIGS. 2-5 are expansions of the block diagram of FIG. 1.

**[0022]** FIG. 6 is a flow chart of a communications method implemented by the communications system of FIGS. 1-5.

**[0023]** FIGS. 7-10 are user interfaces that may be displayed by the communications system of FIGS. 1-5.

**[0024]** FIG. 11 is a flow chart of a communications method implemented by the communications system of FIGS. 1-5.

**[0025]** FIG. 12 is a flow chart of a communications method implemented by the communications system of FIGS. 1-5.

**[0026]** FIGS. 13a, 13b, and 14 are user interfaces that may be displayed by the communications system of FIGS. 1-5.

#### DETAILED DESCRIPTION

**[0027]** For illustrative purposes, FIGS. 1-5 show an example of a communications system for implementing techniques for transferring electronic data. For brevity, several elements in the figures described below are represented as monolithic entities. However, as would be understood by one skilled in the art, these elements each may include numerous interconnected computers and components designed to perform a set of specified operations and/or may be dedicated to a particular geographical region.

**[0028]** Referring to FIG. 1, a communications system 100 is capable of delivering and exchanging data between a client system 105 and a host system 110 through a communications link 115. The client system 105 typically includes one or more client devices 120 and/or client controllers 125, and the host system 110 typically includes one or more host devices 135 and/or host controllers 140. For example, the client system 105 or the host system 110 may include one or more general-purpose computers (e.g., personal computers), one or more special-purpose computers (e.g., devices specifically programmed to communicate with each other and/or the client system 105 or the host system 110), or a combination of one or more general-purpose computers and one or more special-purpose computers. The client system 105 and the host system 110 may be arranged to operate within or in concert with one or more other systems, such as, for example, one or more LANs (“Local Area Networks”) and/or one or more WANs (“Wide Area Networks”).

**[0029]** The client device 120 (or the host device 135) is generally capable of executing instructions under the command of a client controller 125 (or a host controller 140). The client device 120 (or the host device 135) is connected to the

client controller 125 (or the host controller 140) by a wired or wireless data pathway 130 or 145 capable of delivering data.

**[0030]** The client device 120, the client controller 125, the host device 135, and the host controller 140 each typically include one or more hardware components and/or software components. An example of a client device 120 or a host device 135 is a general-purpose computer (e.g., a personal computer) capable of responding to and executing instructions in a defined manner. Other examples include a special-purpose computer, a workstation, a server, a device, a component, other physical or virtual equipment or some combination thereof capable of responding to and executing instructions. The client device 120 and the host device 135 may include devices that are capable of peer-to-peer communications.

**[0031]** An example of a client controller 125 or a host controller 140 is a software application loaded on the client device 120 or the host device 135 for commanding and directing communications enabled by the client device 120 or the host device 135. Other examples include a program, a piece of code, an instruction, a device, a computer, a computer system, or a combination thereof, for independently or collectively instructing the client device 120 or the host device 135 to interact and operate as described. The client controller 125 and the host controller 140 may be embodied permanently or temporarily in any type of machine, component, physical or virtual equipment, storage medium, or propagated signal capable of providing instructions to the client device 120 or the host device 135.

**[0032]** The communications link 115 typically includes a delivery network 160 making a direct or indirect communication between the client system 105 and the host system 110, irrespective of physical separation. Examples of a delivery network 160 include the Internet, the World Wide Web, WANs, LANs, analog or digital wired and wireless telephone networks (e.g. PSTN, ISDN, and xDSL), radio, television, cable, satellite, and/or any other delivery mechanism for carrying data. The communications link 115 may include communication pathways 150 and 155 that enable communications through the one or more delivery networks 160 described above. Each of the communication pathways 150 and 155 may include, for example, a wired, wireless, cable or satellite communication pathway.

**[0033]** FIG. 2 illustrates a communications system 200 including a client system 205 communicating with a host system 210 through a communications link 215. Client system 205 typically includes one or more client devices 220 and one or more client controllers 225 for controlling the client devices 220. Host system 210 typically includes one or more host devices 235 and one or more host controllers 240 for controlling the host devices 235. The communications link 215 may include communication pathways 250 and 255 that enable communications through the one or more delivery networks 260.

**[0034]** Examples of each element within the communications system of FIG. 2 are broadly described above with respect to FIG. 1. In particular, the host system 210 and communications link 215 typically have attributes comparable to those described with respect to the host system 110 and the communications link 115 of FIG. 1. Likewise, the client system 205 of FIG. 2 typically has attributes comparable to and illustrates one possible implementation of the client system 105 of FIG. 1.

[0035] The client device 220 typically includes a general-purpose computer 270 having an internal or external storage 272 for storing data and programs such as an operating system 274 (e.g., DOS, Windows™, Windows 95™, Windows 95™, Windows 2000™, Windows Me™, Windows XP™, Windows NT™, OS/2, or Linux) and one or more application programs. Examples of application programs include authoring applications 276 (e.g., word processing programs, database programs, spreadsheet programs, or graphics programs) capable of generating documents or other electronic content; client applications 278 (e.g., AOL client, CompuServe client, AIM client, AOL TV client, or ISP client) capable of communicating with other computer users, accessing various computer resources, and viewing, creating, or otherwise manipulating electronic content; and browser applications 280 (e.g., Netscape's Navigator or Microsoft's Internet Explorer) capable of rendering standard Internet content.

[0036] The general-purpose computer 270 also includes a central processing unit 282 (CPU) for executing instructions in response to commands from the client controller 225. In one implementation, the client controller 225 includes one or more of the application programs installed on the internal or external storage 272 of the general-purpose computer 270. In another implementation, the client controller 225 includes application programs externally stored in and performed by one or more device(s) external to the general-purpose computer 270.

[0037] The general-purpose computer typically will include a communication device 284 for sending and receiving data. One example of the communication device 284 is a modem. Other examples include a transceiver, a set-top box, a communication card, a satellite dish, an antenna, or another network adapter capable of transmitting and receiving data over the communications link 215 through a wired or wireless data pathway 250. The general-purpose computer 270 also may include a TV tuner 286 for receiving television programming in the form of broadcast, satellite, and/or cable TV signals. As a result, the client device 220 can selectively and/or simultaneously display network content received by communications device 284 and television programming content received by the TV tuner 286.

[0038] The general-purpose computer 270 typically will include an input/output interface 288 for wired or wireless connection to various peripheral devices 290. Examples of peripheral devices 290 include, but are not limited to, a mouse 291, a mobile phone 292, a personal digital assistant 293 (PDA), an MP3 player (not shown), a keyboard 294, a display monitor 295 with or without a touch screen input, a TV remote control 296 for receiving information from and rendering information to subscribers, and an audiovisual input device 298.

[0039] Although FIG. 2 illustrates devices such as a mobile telephone 292, a PDA 293, an MP3 player (not shown), and a TV remote control 296 as being peripheral with respect to the general-purpose computer 270, in another implementation, such devices may themselves include the functionality of the general-purpose computer 270 and operate as the client device 220. For example, the mobile phone 292 or the PDA 293 may include computing and networking capabilities and function as a client device 220 by accessing the delivery network 260 and communicating with the host system 210. Furthermore, the client system 205 may include one, some or all of the components and devices described above.

[0040] Referring to FIG. 3, a communications system 300 is capable of delivering and exchanging information between a client system 305 and a host system 310 through a communication link 315. Client system 305 typically includes one or more client devices 320 and one or more client controllers 325 for controlling the client devices 320. Host system 310 typically includes one or more host devices 335 and one or more host controllers 340 for controlling the host devices 335. The communications link 315 may include communication pathways 350 and 355 that enable communications through the one or more delivery networks 360.

[0041] Examples of each element within the communications system of FIG. 3 are broadly described above with respect to FIGS. 1 and 2. In particular, the client system 305 and the communications link 315 typically have attributes comparable to those described with respect to client systems 105 and 205 and communications links 115 and 215 of FIGS. 1 and 2. Likewise, the host system 310 of FIG. 3 may have attributes comparable to and illustrates one possible implementation of the host systems 110 and 210 shown in FIGS. 1 and 2.

[0042] The host system 310 includes a host device 335 and a host controller 340. The host controller 340 is generally capable of transmitting instructions to any or all of the elements of the host device 335. For example, in one implementation, the host controller 340 includes one or more software applications loaded on the host device 335. In other implementations, as described above, the host controller 340 may include any of several other programs, machines, and devices operating independently or collectively to control the host device 335.

[0043] The host device 335 includes a login server 370 for enabling access by subscribers and for routing communications between the client system 305 and other elements of the host device 335. The host device 335 also includes various host complexes such as the depicted OSP ("Online Service Provider") host complex 380 and IM ("Instant Messaging") host complex 390. To enable access to these host complexes by subscribers, the client system 305 includes communication software, for example, an OSP client application and an IM client application. The OSP and IM communication software applications are designed to facilitate the subscriber's interactions with the respective services and, in particular, may provide access to all the services available within the respective host complexes.

[0044] Typically, the OSP host complex 380 supports different services, such as e-mail, discussion groups, chat, news services, and Internet access. The OSP host complex 380 is generally designed with an architecture that enables the machines within the OSP host complex 380 to communicate with each other and employs certain protocols (i.e., standards, formats, conventions, rules, and structures) to transfer data. The OSP host complex 380 ordinarily employs one or more OSP protocols and custom dialing engines to enable access by selected client applications. The OSP host complex 380 may define one or more specific protocols for each service based on a common, underlying proprietary protocol.

[0045] The IM host complex 390 is generally independent of the OSP host complex 380, and supports instant messaging services irrespective of a subscriber's network or Internet access. Thus, the IM host complex 390 allows subscribers to send and receive instant messages, whether or not they have access to any particular ISP. The IM host complex 390 may support associated services, such as administrative matters,

advertising, directory services, chat, and interest groups related to instant messaging. The IM host complex 390 has an architecture that enables all of the machines within the IM host complex to communicate with each other. To transfer data, the IM host complex 390 employs one or more standard or exclusive IM protocols.

[0046] The host device 335 may include one or more gateways that connect and therefore link complexes, such as the OSP host complex gateway 385 and the IM host complex gateway 395. The OSP host complex gateway 385 and the IM host complex gateway 395 may directly or indirectly link the OSP host complex 380 with the IM host complex 390 through a wired or wireless pathway. Ordinarily, when used to facilitate a link between complexes, the OSP host complex gateway 385 and the IM host complex gateway 395 are privy to information regarding the protocol type anticipated by a destination complex, which enables any necessary protocol conversion to be performed incident to the transfer of data from one complex to another. For instance, the OSP host complex 380 and IM host complex 390 generally use different protocols such that transferring data between the complexes requires protocol conversion by or at the request of the OSP host complex gateway 385 and/or the IM host complex gateway 395.

[0047] Referring to FIG. 4, a communications system 400 is capable of delivering and exchanging information between a client system 405 and a host system 410 through a communication link 415. Client system 405 typically includes one or more client devices 420 and one or more client controllers 425 for controlling the client devices 420. Host system 410 typically includes one or more host devices 435 and one or more host controllers 440 for controlling the host devices 435. The communications link 415 may include communication pathways 450 and 455 that enable communications through the one or more delivery networks 460. As shown, the client system 405 may access the Internet 465 through the host system 410.

[0048] Examples of each element within the communications system of FIG. 4 are broadly described above with respect to FIGS. 1-3. In particular, the client system 405 and the communications link 415 typically have attributes comparable to those described with respect to client systems 105, 205, and 305 and communications links 115, 215, and 315 of FIGS. 1-3. Likewise, the host system 410 of FIG. 4 may have attributes comparable to and illustrates one possible implementation of the host systems 110, 210, and 310 shown in FIGS. 1-3. FIG. 4 describes an aspect of the host system 410, focusing primarily on one particular implementation of OSP host complex 480.

[0049] The client system 405 includes a client device 420 and a client controller 425. The client controller 425 is generally capable of establishing a connection to the host system 410, including the OSP host complex 480, the IM host complex 490 and/or the Internet 465. In one implementation, the client controller 425 includes an OSP application for communicating with servers in the OSP host complex 480 using exclusive OSP protocols. The client controller 425 also may include applications, such as an IM client application, and/or an Internet browser application, for communicating with the IM host complex 490 and the Internet 465.

[0050] The host system 410 includes a host device 435 and a host controller 440. The host controller 440 is generally capable of transmitting instructions to any or all of the elements of the host device 435. For example, in one implemen-

tation, the host controller 440 includes one or more software applications loaded on one or more elements of the host device 435. In other implementations, as described above, the host controller 440 may include any of several other programs, machines, and devices operating independently or collectively to control the host device 435.

[0051] The host system 410 includes a login server 470 capable of enabling communications with and authorizing access by client systems 405 to various elements of the host system 410, including an OSP host complex 480 and an IM host complex 490. The login server 470 may implement one or more authorization procedures to enable simultaneous access to the OSP host complex 480 and the IM host complex 490. The OSP host complex 480 and the IM host complex 490 are connected through one or more OSP host complex gateways 485 and one or more IM host complex gateways 495. Each OSP host complex gateway 485 and IM host complex gateway 495 may perform any protocol conversions necessary to enable communications between the OSP host complex 480, the IM host complex 490, and the Internet 465.

[0052] The OSP host complex 480 supports a set of services from one or more servers located internal to and external from the OSP host complex 480. Servers external to the OSP host complex 480 generally may be viewed as existing on the Internet 465. Servers internal to the OSP complex 480 may be arranged in one or more configurations. For example, servers may be arranged in centralized or localized clusters in order to distribute servers and subscribers within the OSP host complex 480.

[0053] In one implementation of FIG. 4, the OSP host complex 480 includes a routing processor 4802. In general, the routing processor 4802 will examine an address field of a data request, use a mapping table to determine the appropriate destination for the data request, and direct the data request to the appropriate destination. In a packet-based implementation, the client system 405 may generate information requests, convert the requests into data packets, sequence the data packets, perform error checking and other packet-switching techniques, and transmit the data packets to the routing processor 4802. Upon receiving data packets from the client system 405, the routing processor 4802 may directly or indirectly route the data packets to a specified destination within or outside of the OSP host complex 480. For example, in the event that a data request from the client system 405 can be satisfied locally, the routing processor 4802 may direct the data request to a local server 4804. In the event that the data request cannot be satisfied locally, the routing processor 4802 may direct the data request externally to the Internet 465 or the IM host complex 490 through the gateway 485.

[0054] The OSP host complex 480 also includes a proxy server 4806 for directing data requests and/or otherwise facilitating communication between the client system 405 and the Internet 465. The proxy server 4806 may include an IP ("Internet Protocol") tunnel for converting data from OSP protocol into standard Internet protocol and transmitting the data to the Internet 465. The IP tunnel also converts data received from the Internet 465 in the standard Internet protocol back into the OSP protocol and sends the converted data to the routing processor 4802 for delivery back to the client system 405.

[0055] The proxy server 4806 also may allow the client system 405 to use standard Internet protocols and formatting to access the OSP host complex 480 and the Internet 465. For example, the subscriber may use an OSP TV client applica-

tion having an embedded browser application installed on the client system **405** to generate a request in standard Internet protocol, such as HTTP (“HyperText Transport Protocol”). In a packet-based implementation, data packets may be encapsulated inside a standard Internet tunneling protocol, such as, for example, UDP (“User Datagram Protocol”) and routed to the proxy server **4806**. The proxy server **4806** may include an L2TP (“Layer Two Tunneling Protocol”) tunnel capable of establishing a point-to-point protocol (PPP) session with the client system **405**.

[0056] The proxy server **4806** also may act as a buffer between the client system **405** and the Internet **465**, and may implement content filtering and time saving techniques. For example, the proxy server **4806** can check parental controls settings of the client system **405** and request and transmit content from the Internet **465** according to the parental control settings. In addition, the proxy server **4806** may include one or more caches for storing frequently accessed information. If requested data is determined to be stored in the caches, the proxy server **4806** may send the information to the client system **405** from the caches and avoid the need to access the Internet **465**.

[0057] Referring to FIG. 5, a communications system **500** is capable of delivering and exchanging information between a client system **505** and a host system **510** through a communication link **515**. Client system **505** typically includes one or more client devices **520** and one or more client controllers **525** for controlling the client devices **520**. Host system **510** typically includes one or more host devices **535** and one or more host controllers **540** for controlling the host devices **535**. The communications link **515** may include communication pathways **550**, **555** enabling communications through the one or more delivery networks **560**. As shown, the client system **505** may access the Internet **565** through the host system **510**.

[0058] Examples of each element within the communications system of FIG. 5 are broadly described above with respect to FIGS. 1-4. In particular, the client system **505** and the communications link **515** typically have attributes comparable to those described with respect to client systems **105**, **205**, **305**, and **405** and communications links **115**, **215**, **315**, and **415** of FIGS. 1-4. Likewise, the host system **510** of FIG. 5 may have attributes comparable to and illustrates one possible implementation of the host systems **110**, **210**, **310**, and **410** shown in FIGS. 1-4. FIG. 5 describes an aspect of the host system **510**, focusing primarily on one particular implementation of IM host complex **590**.

[0059] The client system **505** includes a client device **520** and a client controller **525**. The client controller **525** is generally capable of establishing a connection to the host system **510**, including the OSP host complex **580**, the IM host complex **590** and/or the Internet **565**. In one implementation, the client controller **525** includes an IM application for communicating with servers in the IM host complex **590** using exclusive IM protocols. The client controller **525** also may include applications, such as an OSP client application, and/or an Internet browser application for communicating with the OSP host complex **580** and the Internet **565**, respectively.

[0060] The host system **510** includes a host device **535** and a host controller **540**. The host controller **540** is generally capable of transmitting instructions to any or all of the elements of the host device **535**. For example, in one implementation, the host controller **540** includes one or more software applications loaded on one or more elements of the host

device **535**. However, in other implementations, as described above, the host controller **540** may include any of several other programs, machines, and devices operating independently or collectively to control the host device **535**.

[0061] The host system **510** includes a login server **570** capable of enabling communications with and authorizing access by client systems **505** to various elements of the host system **510**, including an OSP host complex **580** and an IM host complex **590**. The login server **570** may implement one or more authorization procedures to enable simultaneous access to the OSP host complex **580** and the IM host complex **590**. The OSP host complex **580** and the IM host complex **590** are connected through one or more OSP host complex gateways **585** and one or more IM host complex gateways **595**. Each OSP host complex gateway **585** and IM host complex gateway **595** may perform any protocol conversions necessary to enable communication between the OSP host complex **580**, the IM host complex **590**, and the Internet **565**.

[0062] To access the IM host complex **590** and begin an IM session, the client system **505** establishes a connection to the login server **570**. The login server **570** typically determines whether the particular subscriber is authorized to access the IM host complex **590** by verifying a subscriber identification and password. If the subscriber is authorized to access the IM host complex **590**, the login server **570** employs a hashing technique on the subscriber’s screen name to identify a particular IM server **5902** for use during the subscriber’s session. The login server **570** provides the client system **505** with the IP address of the particular IM server **5902**, gives the client system **505** an encrypted key (i.e., a cookie), and breaks the connection. The client system **505** then uses the IP address to establish a connection to the particular IM server **5902** through the communications link **515**, and obtains access to that IM server **5902** using the encrypted key. Typically, the client system **505** will be equipped with a Winsock API (“Application Programming Interface”) that enables the client system **505** to establish an open TCP connection to the IM server **5902**.

[0063] Once a connection to the IM server **5902** has been established, the client system **505** may directly or indirectly transmit data to and access content from the IM server **5902** and one or more associated domain servers **5904**. The IM server **5902** supports the fundamental instant messaging services and the domain servers **5904** may support associated services, such as, for example, administrative matters, directory services, chat and interest groups. In general, the purpose of the domain servers **5904** is to lighten the load placed on the IM server **5902** by assuming responsibility for some of the services within the IM host complex **590**. By accessing the IM server **5902** and/or the domain server **5904**, a subscriber can use the IM client application to view whether particular subscribers (“buddies”) are online, exchange instant messages with particular subscribers, participate in group chat rooms, trade files such as pictures, invitations or documents, find other subscribers with similar interests, get customized news and stock quotes, and search the World Wide Web.

[0064] In the implementation of FIG. 5, the IM server **5902** is directly or indirectly connected to a routing gateway **5906**. The routing gateway **5906** facilitates the connection between the IM server **5902** and one or more alert multiplexors **5908**, for example, by serving as a link minimization tool or hub to connect several IM servers **5902** to several alert multiplexors **5908**. In general, an alert multiplexor **5908** maintains a record of alerts and subscribers registered to receive the alerts.

[0065] Once the client system 505 is connected to the alert multiplexor 5908, a subscriber can register for and/or receive one or more types of alerts. The connection pathway between the client system 505 and the alert multiplexor 5908 is determined by employing another hashing technique at the IM server 5902 to identify the particular alert multiplexor 5908 to be used for the subscriber's session. Once the particular multiplexor 5908 has been identified, the IM server 5902 provides the client system 505 with the IP address of the particular alert multiplexor 5908 and gives the client system 505 an encrypted key (i.e., a cookie). The client system 505 then uses the IP address to connect to the particular alert multiplexor 5908 through the communication link 515 and obtains access to the alert multiplexor 5908 using the encrypted key.

[0066] The alert multiplexor 5908 is connected to an alert gate 5910 that, like the IM host complex gateway 595, is capable of performing the necessary protocol conversions to form a bridge to the OSP host complex 580. The alert gate 5910 is the interface between the IM host complex 590 and the physical servers, such as servers in the OSP host complex 580, where state changes are occurring. In general, the information regarding state changes will be gathered and used by the IM host complex 590. However, the alert multiplexor 5908 also may communicate with the OSP host complex 580 through the IM host complex gateway 595, for example, to provide the servers and subscribers of the OSP host complex 580 with certain information gathered from the alert gate 5910.

[0067] The alert gate 5910 can detect an alert feed corresponding to a particular type of alert. The alert gate 5910 may include a piece of code (alert receive code) capable of interacting with another piece of code (alert broadcast code) on the physical server where a state change occurs. In general, the alert receive code installed on the alert gate 5910 instructs the alert broadcast code installed on the physical server to send an alert feed to the alert gate 5910 upon the occurrence of a particular state change. Upon detecting an alert feed, the alert gate 5910 contacts the alert multiplexor 5908, which in turn, informs the client system 505 of the detected alert feed.

[0068] In the implementation of FIG. 5, the IM host complex 590 also includes a subscriber profile server 5912 connected to a database 5914 for storing large amounts of subscriber profile data. The subscriber profile server 5912 may be used to enter, retrieve, edit, manipulate, or otherwise process subscriber profile data. In one implementation, a subscriber's profile data includes, for example, the subscriber's buddy list, alert preferences, to designated stocks, identified interests, and geographic location. The subscriber may enter, edit and/or delete profile data using an installed IM client application on the client system 505 to interact with the subscriber profile server 5912.

[0069] Because the subscriber's data is stored in the IM host complex 590, the subscriber does not have to reenter or update such information in the event that the subscriber accesses the IM host complex 590 using a new or a different client system 505. Accordingly, when a subscriber accesses the IM host complex 590, the IM server 5902 can instruct the subscriber profile server 5912 to retrieve the subscriber's profile data from the database 5914 and to provide, for example, the subscriber's buddy list to the IM server 5902 and the subscriber's alert preferences to the alert multiplexor 5908. The subscriber profile server 5912 also may communicate with other servers in the OSP host complex 580 to share

subscriber profile data with other services. Alternatively, user profile data may be saved locally on the client device 505.

[0070] Referring to FIG. 6, a sender 602a, a recipient 602b, and a host 604 exchange communications according to a procedure 600. The procedure 600 may be implemented by any suitable type of hardware (e.g., device, computer, computer system, equipment, component); software (e.g., program, application, instructions, code); storage medium (e.g., disk, external memory, internal memory, propagated signal); or combination thereof.

[0071] Examples of each element of FIG. 6 are broadly described with respect to FIGS. 1-5 above. In particular, the sender 602a and the recipient 602b may have attributes comparable to those described with respect to client devices 120, 220, 320, 420, and 520 and/or client controllers 125, 225, 325, 425, and 525. The host 604 may have attributes comparable to those described with respect to host devices 135, 235, 335, 435, and 535 and/or host controllers 140, 240, 340, 440, and 540. The sender 602a, the recipient 602b, and/or the host 604 may be directly or indirectly interconnected through a known or described delivery network, such as delivery networks 160, 260, 360, 460, and 560.

[0072] In one implementation, the sender 602a is associated with a first subscriber, the recipient 602b is associated with a second subscriber, and each of the sender 602a and the recipient 602b includes an application for accessing the host 604. A subscriber's transfer preferences may be maintained locally at the application or remotely at the host 604. Each subscriber may use the application to set individual preferences for allowing messages and/or files to be transferred to and from other subscribers. Typically, a graphical user interface ("UI") is displayed to allow each subscriber to select among various levels of security and/or to grant (or deny) access to others subscribers. For example, transfer preferences may be set to allow all users or only certain users (e.g., users included in the subscriber's buddy list) to contact the recipient 602b. If the transfer preferences of the recipient 602b have been set to block a subscriber attempting contact, the sender 602a may display a UI indicating that instant messaging with the recipient 602b is unavailable.

[0073] More specifically, the sender 602a is a subscriber and/or a client (e.g., client system 505), and the host 604 includes one or more host complexes (e.g., OSP host complex 580 and/or IM host complex 590) for providing instant messaging capability and coordinating the transfer of electronic data between subscribers. The sender 602a may access the host 604 using any available device and/or controller.

[0074] An example of a device is a general-purpose computer capable of responding to and executing instructions in a defined manner. Other examples include a special-purpose computer, a personal computer ("PC"), a workstation, a server, a laptop, a Web-enabled telephone, a Web-enabled personal digital assistant ("PDA"), an interactive television set, a settop box, a video tape recorder ("VTR"), a DVD player, an on-board (i.e., vehicle-mounted) computer, or any other component, machine, tool, equipment, or some combination thereof capable of responding to and executing instructions.

[0075] An example of a controller is a software application (e.g., operating system, browser application, microbrowser application, server application, proxy application, gateway application, tunneling application, e-mail application, IM client, online service provider client application, interactive television client application, and/or ISP client) loaded on a

device to command and direct communications enabled by the device. Other examples include a computer program, a piece of code, an instruction, another device, or some combination thereof, for independently or collectively instructing the device to interact and operate as desired. The controller may be embodied permanently or temporarily in any type of machine, component, physical or virtual equipment, storage medium, or propagated signal capable of providing instructions to a device. In particular, the controller (e.g., software application, computer Program) may be stored on a storage media or device (e.g., ROM, magnetic diskette, or propagated signal) readable by a general or special purpose programmable computer, such that if the storage media or device is read by a computer system, the functions described herein are performed.

**[0076]** In the following example, it is assumed that the transfer preferences are set to allow messages and files to be transferred between the sender **602a** and the recipient **602b**. To communicate using instant messaging, the sender **602a** and the recipient **602b** access the host **604** concurrently. In order to access the host **604**, the sender **602a** and the recipient **602b** each separately request authentication or recognition by the host **604**. The request identifies the associated subscriber to the host **604** for subsequent identification to other subscribers using a unique screen name. The sender **602a** and the recipient **602b** each may include a Winsock API for opening and establishing a TCP connection to the host **604**.

**[0077]** The host **604** verifies a subscriber's information (e.g., screen name and password) against data stored in a subscriber database. If the subscriber's information is verified, the host **604** authorizes access and or acknowledges the subscriber. If the subscriber's information is not verified, the host **604** denies access and sends an error message.

**[0078]** After being authorized, a direct (i.e., socket) connection may be established through the host **604** to allow the sender **602a** and the recipient **602b** to communicate. The sender **602a** and the recipient **602b** use this connection to communicate with the host **604** and with each other. This connection remains available during the time that the sender **602a** and the recipient **602b** are accessing the host **604**, or until either party decides to terminate.

**[0079]** Upon accessing the host **604**, a "buddy list" is displayed to the subscriber. In general, a subscriber's buddy list is maintained with or accessible as part of a subscriber's user profile and may be made accessible using a user interface (UI) that provides the online status and capabilities of certain screen names, i.e., "buddies," identified by the subscriber. In particular, the host **604** informs the sender **602a** whether identified buddies are online, i.e., currently accessing the host **604**. The host **604** also informs any subscriber who has identified the sender **602a** as a buddy that the sender **602a** is currently online.

**[0080]** A buddy list may be used to facilitate IM communications between subscribers. For example, a subscriber can activate an IM user interface that is pre-addressed to a buddy simply by selecting the screen name of an online buddy from the buddy list.

**[0081]** Alternatively, by way of example, if a recipient is not a "buddy," the first subscriber generally initiates IM communications by activating a blank IM user interface and then addressing that interface to the screen name of the intended recipient. When necessary, a subscriber can look up the screen name of an intended recipient using the intended recipient's e-mail address.

**[0082]** In the implementation of FIG. 6, a sender **602a**, a recipient **602b**, and a host **604** interact according to a procedure **600** that extends the functionality of instant messaging by passively personalizing the buddy list of at least one of the sender **602a** and the recipient **602b**.

**[0083]** Initially, the sender **602a** accesses the host **604** (step **606**). The sender **602a** designates at least one recipient **602b** to receive an instant message (step **608**). The instant message may be, for example, a text or non-text (e.g., audio, video) instant message created by the sender **602a**.

**[0084]** More specifically, in one implementation of this process in which the sender **602a** has previously designated a screen name associated with the intended recipient **602b** as a "buddy;" a UI (e.g., buddy list) indicating the online status and capabilities of the recipient **602b** is displayed to the sender **602a**. Thus, the sender **602a** can confirm that the recipient **602b** is able to communicate (i.e., is online) and then designate the recipient **602b** for receipt of an instant message by selecting (e.g., clicking) the screen name associated with the recipient **602b** to open an IM interface (step **608**).

**[0085]** After an IM recipient is selected (step **608**), the host **604** detects the capabilities of the recipient (step **610**) and reports the capabilities of the recipient **602b** to the sender **602a** (step **612**). In one implementation, a network of servers (e.g., IM servers **5902**) on the host **604** monitors and updates the online status, client version, and device type of connected subscribers and reports or enables access to this information by other subscribers in real time or substantially in real time. Yet, the accuracy and timeliness of information reported using an instant messaging interface may depend on factors such as a subscriber's hardware (e.g., device type), software (e.g., client version), and/or transfer preferences (e.g., blocked screen names).

**[0086]** Next, the sender **602a** receives the report from the host **604** (step **614**) and displays a UI corresponding to the capabilities of the sender **602a** and/or the recipient **602b** (step **616**). In general, if the sender **602a** (e.g., client system **505**) is not voice-enabled and/or video-enabled, the sender **602a** displays a standard instant messaging UI. If the sender **602a** is voice-enabled and/or video-enabled, then the sender **602a** may be configured to display a voice-enabled and/or video-enabled UI.

**[0087]** The sender **602a** then composes a message in the IM interface (step **618**) and transmits the instant message to the host **604** (step **620**). In general, the sender transmits the message by selecting a send button.

**[0088]** The host **604** receives the instant message from the sender **602a** (step **622**) and then optionally authenticates the instant message (step **624**). In one implementation, the instant message includes header information identifying the message type, the screen name and/or IP address of the sender **602a** and the recipient **602b**, and a randomly generated security number. A server (e.g., IM server **5902**) on the host **604** may authenticate the instant message by matching the screen names and/or IP addresses with those of valid subscribers stored in a reverse look-up table. In the event that either the sender **602a** or the recipient **602b** is not associated with a valid subscriber, the host **604** reports an error message. The host **604** then sends the instant message to the recipient **602b** (step **626**).

**[0089]** The recipient **602b** receives the instant message from the host (step **628**) and then accepts the instant message (step **630**). Accepting the instant message may occur auto-

matically if the subscriber that sent the instant message has been preauthorized according to the transfer preferences of the recipient **602b**.

**[0090]** For example, acceptance may occur automatically if the sender **602a** is included on a buddy list maintained by the recipient **602b**. Alternatively, accepting the instant message may include displaying a warning UI based on the transfer preferences of the recipient **602b**. For example, the preferences of the recipient **602b** may be set to present an “accept message” dialog before displaying messages from any users or certain users (e.g., users not included in the subscriber’s buddy list).

**[0091]** After the instant message is accepted (step **630**), the host establishes an IM session (step **632**) that enables the sender **602a** and the recipient **602b** to communicate substantially in real time. Establishing an IM session generally involves connecting one or more communication channels for transferring data between the sender **602a** and the recipient **602b**. The communication channels may allow the sender **602a** and the recipient **602b** to transfer data directly with each other (e.g., over a peer-to-peer connection) or may require the data to pass through an intermediary (e.g., host **604**).

**[0092]** An active IM session may use one or more communication channels, such as, for example, a generic signaling interface (GSI) channel, a control channel, and a data channel. The GSI channel may be used to establish the initial connection. During this connection, the local IP addresses are exchanged. After the initial connection phase is done, the GSI channel is no longer used. By using the GSI channel, the exchange of local IP addresses is done only when both subscribers authorize such an exchange. Thus, using the GSI channel protects subscribers from having their local IP addresses automatically obtained without their consent.

**[0093]** The control channel is typically a TCP/IP socket for which the IP address and port number of the remote side are obtained through the GSI channel. The control channel may be used to send/receive control attributes of an active session. For example, because some firewalls will not allow a connection to be initiated by an external device with a socket on the inside of the firewall, a connection is attempted from both sides of the session.

**[0094]** The data channel also is typically a TCP/IP socket, and is used to transport data packets using various protocols such as UDP and TCP. In general, UDP is used since it minimizes latency. However, because some firewalls will not allow UDP packets to pass through, the data channel may use a different protocol, such as TCP. The client may indicate a particular mode (i.e., TCP, UDP) or, alternatively, an auto mode where it attempts a UDP test, and upon failure resorts to a secondary protocol (e.g., TCP).

**[0095]** When an IM session has been established successfully (step **632**), the sender **602a** and the recipient **602b** may exchange communications substantially in real time. In one implementation, the recipient **602b** displays an instant message received from the sender **602a** (step **634**). Referring to FIG. 7, for example, a UI **700** that may be displayed by the sender **602a** and/or the recipient **602b** includes an IM window **705** for displaying a running transcript of an IM session and a text message area **710** for entering the text of an instant message. In this example, the IM session includes a first instant message **705** from a first subscriber having a first screen name (ProductRep) and second instant message **707** from a second subscriber having a second screen name (Subscriber). Although the first and second subscribers of this

example have each sent and received instant messages, the following description is provided with reference to the first subscriber as being associated with the sender **602a** and the second subscriber as being associated with the recipient **602b**.

**[0096]** The UI **700** also includes an IM toolbar **715** for changing text or background colors, changing text size, emphasizing text (e.g., bold, italic, or underlining), and inserting objects (e.g., emoticons, hyperlinks, images). In addition, the UI **700** includes IM buttons **720** for performing IM functions such as notifying the OSP of offending conduct, blocking a subscriber, adding an IM contact (e.g., buddy), initiating an audio (or video) IM session, getting the profile of a sender, and sending instant messages.

**[0097]** When an IM session is closed, the sender **602a** and the recipient **602b** may not exchange communications until a new IM session is established between the sender **602a** and the recipient **602b**. An IM session may be closed when the participants close the IM window **705**, when either the sender **602a** or the recipient **602b** disconnects from the host **604**, or when a configurable period of time has passed during which no communications are exchanged between the sender **602a** and the recipient **602b**.

**[0098]** During an active IM session, the host **604** may moderate the IM session. In one implementation, a server (e.g., IM server **5902**, domain server **5904**) on the host **604** is configured to moderate an IM session between at least one sender **602a** and at least one recipient **602b**. Moderating an IM session may include managing load conditions of the host **604** by compressing, decompressing, caching, and/or allocating resources to efficiently store and forward instant messages.

**[0099]** Moderating the IM session also may include updating an IM log (step **636**). In general, an IM log includes a chronological record of IM activity (e.g., the existence or status of separate and/or successful IM sessions, the opening or closing of an IM session, the communication of instant messages during each separate and/or successful IM session, the request or receipt of alerts, or the connection or disconnection with the host). The IM log may be stored and maintained on the host **604** (e.g., by database **5914** of IM host **590**), the sender **602a** (e.g., by memory **272** of the client device), and/or the recipient **602b** (e.g., by memory **272** of the client device). Entries in the IM log may be ordered, deleted, edited, and/or otherwise managed by the host **604**, the sender **602a**, and/or the recipient **602b**. For example, the host **604** may queue, order, and arrange entries in the IM log based on time, subscribers (e.g., screen names), topic, relevance, and/or any other ranking criteria.

**[0100]** Typically, each subscriber will have a corresponding IM log for recording IM activity of the subscriber. However, an IM log may be associated with a group of subscribers, or may simply be used to chronologically log activities of all subscribers communicating over or with the device used to maintain or store the log.

**[0101]** Updating the IM log may include recording the screen names of participants of an IM session. The sender **602a**, the recipient **602b**, and/or the host **604** may be configured to detect at least one identity (e.g., the screen names) associated with an instant message during an IM session, for example, by parsing the header information of an instant message. Typically, the screen names recorded in the IM log of a particular subscriber will be supplemented with information including the time the IM session was established and the screen names of other subscribers that participated in the IM session where several subscribers communicate using group



IM. Updating the IM log also may include tracking the instant messages sent during an IM session and recording the time that each instant message was sent and received, recording the time the IM session was closed, and/or recording the time the sender **602a** or the recipient **602b** disconnected from the host **604**.

[0102] A list of screen names for the most recent IM communications may be derived from the IM log automatically (step **638**). The sender **602a**, the recipient **602b**, and/or the host **604** may be configured to derive such a list. For example, at any time, the last N different screen names with whom a particular subscriber has had an IM session may be determined from an updated IM log. The number N may be any predetermined number set according to preferences of the sender **602a**, the recipient **602b**, and/or the host **604**, or it may be user-selectable.

[0103] In one implementation, the host **604** (e.g., profile server **5912** or IM server **5902**) accesses an IM log associated with a particular subscriber that is stored on the host **604** (e.g., database **5914**). The host **604** examines the IM log and creates a list of N different screen names based on an associated time or a relative position of each screen name. The associated time may be a time that an IM session was established, a time that an instant message was sent (or received), a time that an IM session was completed, a time that the sender **602a** or the recipient **602b** connected to or disconnected from the host **604**, or some other time. Typically, the list of N screen names will be ordered with the most recent screen name being listed first.

[0104] The IM log (and/or the list of most recent IM contacts) may be configured to store only the last N different screen names with which a particular subscriber has had an IM session. The IM log may be maintained using a least recently used methodology. For example, when a new IM session is established, the screen name of each participant may be compared to the list of most recent IM contacts. If the screen name does not already appear in the list, the screen name is added and the least recent IM contact (i.e., oldest IM contact) is reduced in order or altogether removed from the list so that the list includes only N different screen names. If the screen name already appears in the list, the list is reordered so that the screen name appears at the top of the list. In either case, the updated list includes N different screen names listed in order of most recently used IM session. In some implementations, the list may be filtered to include only screen names that do not already appear on the subscriber's buddy list.

[0105] In another example, when an IM session is completed or when either the sender **602a** or the recipient **602b** disconnects from the host **604**, the screen name of each participant may be compared to the list of most recent IM contacts. If the screen name does already appear in the list, the screen name is added and the least recent IM contact (i.e., oldest IM contact) is removed from the list if necessary to maintain only N different screen names on the list; otherwise, the least recent IM contact may be merely demoted. If the screen name already appears in the list, the list is reordered so that the screen name appears at the top of the list. In either case, the final list includes N different screen names listed in order of most recent IM session. In one implementation, the screen name of each participant may be compared to the list of most recent IM contacts only when an IM session is completed or only when either the sender **602a** or the recipient

**602b** disconnects from the host **604** such that the list includes only the most recent IM contacts of the most recent closed IM sessions.

[0106] In another example, the IM log may be maintained using other methodologies, such as, for example a first-in first-out (FIFO) methodology. For example, when a new IM session is established, the screen name of each participant may be added to the list and the screen name first added to the list may be reduced in order or altogether removed from the list, whether or not it was the screen name least recently used actively in a conversation, thus maintaining the threshold number of different screen names. In some implementations, the list may be filtered to include only the screen names that do not already appear on the subscriber's list.

[0107] After a list of N different screen names is compiled, a user profile is accessed (step **640**). In general, a user profile corresponds to a particular subscriber and may include, for example, the subscriber's buddy list, alert preferences, identified interests, geographic location, and user contact information (e.g., phone numbers, e-mail addresses, screen names, and mailing address). The user profile of a subscriber may be stored and maintained on the host **604** (e.g., IM host **590**, database **5914**), the sender **602a** (e.g., client device, memory **272**), and/or the recipient **602b** (e.g., client device, memory **272**). In one implementation, portions of the user profile may be stored and maintained in several remote locations. Typically, a subscriber actively enters, edits and/or deletes the content of the user profile, for example, by using an installed IM client application to fill out an electronic form. In this case, however, access of the user profile may occur transparently to the subscriber. That is, the user profile is accessed without requiring any user action (e.g., selection or configuration by the subscriber). In one implementation, the host **604** (e.g., profile server **5912**, IM server **5902**) accesses the user profile. In other implementations, an installed IM client application is configured to transparently access a local user profile.

[0108] Then, the user profile is passively configured (step **642**). That is, configuration occurs transparently to the subscriber and requires no subscriber action (e.g., selection by the subscriber). Configuration of the user profile may include the creating and/or modifying of a subscriber's user preferences, such as, for example, a buddy list, address book, calendar, notification settings (e.g., alerts), or any other personalized attributes associated with the subscriber.

[0109] In one implementation, a buddy list included in a subscriber's user profile is configured based on the updated IM log. In particular, a buddy list associated with at least one of the sender **602a** and the recipient **602b** may be passively configured to include a list of most recent contacts (step **642**).

[0110] Referring to FIG. 8, a UI **800** that may be passively configured includes a Buddy List Window **805** having a List Setup box **810** (step **644** of FIG. 6). The List Setup box **810** includes one or more IM groups, for example, a Recent Contacts group **812**, a Buddies group **816**, a Co-Workers group **820**, and a Family group **824**. Each IM group includes one or more IM group members identified by screen name, for example, Recent Contacts group members **814**, Buddies group members **818**, Co-Workers group members **822**, and Family group members **826**. The List Setup box **810** also includes List Setup buttons **828** for performing IM functions such as adding a screen name, adding a group, deleting a screen name or group, and finding a screen name of a subscriber. The Buddy List Window **805** further includes Buddy

List buttons **830** for performing IM functions such as linking to an IM-related web page, entering an away message, and setting IM-related user preferences.

**[0111]** In one implementation, the size of the IM groups may be limited to a threshold number of screen names, which may be independent of a size limit established for the entirety of the Buddy List in which it is included. Furthermore, specific IM groups may have different size limitations. For example, the Recent Contacts group **812** may be subject to the threshold number limitation on screen names and the Buddies group **816** may be subject to a different threshold number limitation of screen names, each of which may be different from a size limit of the Buddy List.

**[0112]** The IM groups may be actively or passively created, as discussed below. The Buddies group **816** may be a standard (or default) group provided with every installation of an IM client. In general, when a subscriber opens an IM account, the Buddies group **816** is created automatically. Initially, the Buddies group **816** is empty. To populate the Buddies group **816**, a subscriber must actively enter a screen name for each person with whom the subscriber desires to communicate. For example, using the List Setup Buttons **828**, a subscriber actively entered the screen name for each of the Buddies group members **818** (e.g., Buddy, Friend, Pal). In one implementation, the host **604** (e.g., IM host **590**) provides a reverse lookup function that allows subscribers to search for screen names using various criteria of subscribers (e.g., name, location, e-mail address, interests).

**[0113]** The Co-Workers group **820** and the Family group **824** may be personalized groups actively created by the subscriber. In general, subscribers may personalize their buddy lists by creating different group and categorizing screen names. For example, using the List Setup Buttons **828**, a subscriber can actively create the Co-Workers group **820** and the Family group **824**. After the Co-Workers group **820** and the Family group **824** are created, the subscriber has conventionally been required to actively enter a screen name for each of the Co-Workers group members **822** (e.g., Boss, Employee, Supervisor) and to actively enter a screen name for each of the Family group members **826** (e.g., Brother, Dad, Mom, Sister). A screen name may occupy more than one personalized group.

**[0114]** Like the Buddies Group **816**, the Recent Contacts group **812** may be a standard (or default) group provided with every installation of an IM client. In general, when a subscriber opens an IM account, the Recent Contacts group **812** is created automatically. Initially, the Recent Contacts group **812** is empty. However, unlike the Buddies group **816**, a subscriber does not have to actively enter screen names to populate the Recent Contacts group **812**. That is, the Recent Contacts group **812** may be created, populated and/or modified without user action (e.g., clicks, data entry). For example, screen names are added to and removed from the Recent Contacts group **812** as IM sessions are opened and closed, and/or as membership limits are imposed on the Recent Contacts group. As such, in one implementation, screen names are added to the Recent Contacts group **812** passively, as successful IM sessions are established, used for communication, or closed with the subscriber, and these screen names may be removed from that group **812** as maximum group size is reached. In another example, the screen name of each of the Recent Contacts group members **814** (e.g., Boss, ProductRep, Supervisor, SalesRep, Employee) is passively added to the Recent Contacts group **812** as successful IM session are

closed with the subscriber or when either the sender **602a** or the recipient **602b** disconnects from the host **604**.

**[0115]** In one implementation, the subscriber participates in an IM session with each of the Recent Contacts group members **814** in the following order: Employee, SalesRep, Supervisor, ProductRep, and Boss. As each IM session is established, a screen name for each of the Recent Contacts group members is added in sequence to the Recent Contacts group **812** resulting in the most recent contact being listed first. In this example, the order is implied from the visual hierarchy; however, numeric or other explicit visual indicators also may be used to make clear the relative order of recent IM sessions. Furthermore, in this example, it does not matter which subscriber initiates the IM session (i.e., who sent the initial instant message) or whether a response to the initial instant message is sent. However, the screen names may be ordered, separated into different groups, or otherwise differentiated to reflect this information. A screen name of a particular person may be added whenever a successful IM session is established, used for communication, or closed between the subscriber and the particular person. Screen names included in the Recent Contacts group **812** also may occupy other groups (e.g., Co-Workers group **820**), or, alternatively, the Recent Contacts group **812** may include only the screen name of persons not included in select or all other groups.

**[0116]** In another implementation, as each IM session is completed or when one or both of the sender **602a** or the recipient **602b** disconnects from the host **604**, a screen name for the participant is added in sequence to the Recent Contacts group **812** resulting in the most recently closed/discontinued contact being listed first. Moreover, in this implementation, a screen name of a particular person is added whenever a successful IM session is closed between the subscriber and the particular person or when either subscriber disconnects from the host: In this example, it does not matter which subscriber closed the IM session (e.g., who closed the IM window, who disconnected from the host) or which subscriber disconnected from the host. However, the screen names may be ordered, separated into different groups, or otherwise so differentiated to reflect this information.

**[0117]** Referring to FIG. 9, a UI **900** that may be passively configured includes a Buddy List Window **805** having an Online box **840** (step **644** of FIG. 6). In general, the Online box **840** displays the online status and capabilities of certain screen names identified by the subscriber in the List Setup box, for example, List Setup box **810** of FIG. 8. In one implementation, the host **604** (e.g., IM host **590**, IM server **5902**) informs the sender **602a** (e.g., client device, IM client application) whether the subscribers associated with the screen names are online, i.e., currently accessing the host **604**.

**[0118]** The Online box **840** includes one or more online lists, with each list corresponding to an IM group. For example, the Online box **840** includes a Recent Contacts list **842**, a Buddies list **846**, a Co-Workers list **850**, and a Family list **854**. Several of these online lists (e.g., **846**, **850**, and **854**) include one or more screen names corresponding to IM group members that currently are online. In the implementation of FIG. 9, the Recent Contacts list **842** identifies certain online Recent Contacts members **844**, the Buddies list **846** identifies a certain online Buddies member **846**, the Co-Workers list **850** identifies certain online Co-Workers members **852**, and the Family list **854** identifies a certain online Family member **856**. The Online box **840** also includes an Offline list **858**

identifying offline members **860** from one or more of the IM groups separately (not shown) or collectively. The Online box **840** further includes Online buttons **862** for performing IM functions such as displaying an IM window, sending an invitation to enter a chat room, and finding profile information associated with a screen name.

[0119] The Online box **840** facilitates IM communication between subscribers. For example, a subscriber can activate a pre-addressed IM window simply by clicking the screen name of an online group member.

[0120] Referring to FIG. **10**, a UI **1000** that may be invoked using the buddy list and displayed to the sender **602a** and/or the recipient **602b** includes an IM window **705** including a running transcript of some or all of an IM session and a text message area **710** for entering the text of an instant message, an IM toolbar **715**, and IM buttons **720**. In this example, the IM session includes a first instant message **708** from a first subscriber having a first screen name (Subscriber) and second instant message **709** from a second subscriber having a second screen name (ProductRep). The first subscriber may be associated with the sender **602a** and the second subscriber may be associated with the recipient **602b**.

[0121] Referring to FIG. **11**, in one implementation, the UI **1000** is displayed to a first subscriber associated with a sender **602a** as follows (step **1110**). First, the first subscriber participates in an IM session with each of the Recent Contacts group members **814** in the following order: Employee, SalesRep, Supervisor, ProductRep, and Boss (step **1120**). As each IM session is established, a screen name for each of the Recent Contacts group members is added in sequence to the Recent Contacts group **812** resulting in the most recent contact being listed first (step **1130a**). Additionally and/or alternatively, as each IM session is closed (step **1130b**), or when either the sender or the recipient disconnect from the host (step **1130c**), a screen name for each of the Recent Contacts group members is added in sequence to the Recent Contacts group **812** resulting in the most recently closed/discontinued contact being listed first. Screen names included in the Recent Contacts group **812** also may occupy other groups (e.g., Co-Workers group **820**).

[0122] Still further, the order of screen names within the Recent Contacts group **812** may be rearranged based on the relative time of session closure or disconnection. For instance, assume that a first IM session with Employee X is opened and closed, a second IM session with Employee Y is subsequently opened and closed, and a third IM session with Employee X is later opened and closed. In this case, before the third IM session is initiated, the Recent Contacts group **812** may order Employee Y ahead of Employee X since the second IM session opened and/or closed before the first IM session. However, after the third IM session, their order may be reversed to reflect the opening and/or closing of an IM session (the third) with Employee X, which occurred more recently than with Employee Y.

[0123] In any of these implementations, the Recent Contacts group **812** only may include the screen name of a particular person that is not included in any other group.

[0124] Next, the first subscriber views a UI **900** indicating the online status of an intended recipient of an instant message. In this example, the first subscriber intends to send an instant message to the second subscriber. Here, the screen name of the second subscriber (ProductRep) was not actively added to the UI **900** by the first subscriber. Rather, the screen name (ProductRep) was added passively to the Recent Con-

tacts group **812** when the first subscriber and second subscriber established used, closed or disconnected a prior successful IM session. By viewing the UI **900** and, in particular, the Recent Contacts list **842**, the first subscriber is notified that the second subscriber is online. Namely, the screen name of the second subscriber (ProductRep) appears as one of the online Recent Contact members **844**.

[0125] The first subscriber then sends an instant message intended for the second subscriber by interacting with the UI **900**. For example, the first subscriber can invoke display of an IM UI **1000** pre-addressed to the second subscriber by clicking the screen name of the second subscriber (ProductRep) in the Recent Contacts list **842**. The first subscriber enters the first instant message **708** into the text message area **710** and clicks one of the IM buttons **720**, namely the send button. Finally, the first subscriber displays the second instant message **709** (i.e., the reply from the second subscriber) in the IM window **705**.

[0126] Passively configuring a user profile, and hence a passively configured subscriber buddy list, benefits subscribers by facilitating IM communication. For example, a subscriber can view the online status of and create pre-addressed instant messages to recent IM contacts. This feature is particularly helpful to new IM users who would otherwise have to spend time and effort setting user preferences and entering data. Additionally, it is helpful to subscribers who accidentally or intentionally close sessions with IM contacts for whom they have no other record of their screen name, only to need that screen name for later IM contact. The persistent state of the recent IM contacts list enables the list to persist through log-outs and power downs.

[0127] Additionally, a passively configured user profile, and hence a passively configured subscriber buddy list, may be made accessible through any of several different devices independent of the device that was being used at the time of the IM session that resulted in the passive addition of or status change with respect to the IM contact in the Recent Contacts group. For example, in a client-host model, the profile may be stored at the host or some other location centrally accessible to various client devices operable by the subscriber. As a result, a first subscriber may participate in an instant messaging session with a second subscriber using a personal computer. At the end of the instant messaging session, the screen name of the second subscriber may be passively added to the first subscriber's Recent Contacts group. When the first subscriber later uses a PDA to access the IM service, the first subscriber's Recent Contacts group may be presented on the PDA. In this instance, the Recent Contacts group includes the screen name of the second subscriber that was added to the group based on the IM session that the first subscriber participated in using the personal computer. This enables the first subscriber to initiate another IM session with the second subscriber by selecting the second subscriber's screen name from the Recent Contacts group presented on the PDA. Thus, the passively configured buddy list, specifically the Recent Contact Group, persists across different devices.

[0128] In one implementation, a passively configured user profile and/or a passively configured buddy list may include information from communication sessions other than IM sessions. Referring to FIG. **12**, a sender **1202a**, a recipient **1202b**, and a host **1204** exchange communications according to a procedure **1200**. The procedure **1200** may be implemented by any suitable type of hardware (e.g., device, computer, computer system, equipment, component); software

(e.g., program, application, instructions, code); storage medium (e.g., disk, external memory, internal memory, propagated signal); or combination thereof.

[0129] Examples of each element of FIG. 12 are broadly described with respect to FIGS. 1-5 above. In particular, the sender 1202a and the recipient 1202b may have attributes comparable to those described above with respect to client devices 120, 220, 320, 420, and 520 and/or client controllers 125, 225, 325, 425, and 525. The host 1204 may have attributes comparable to those described above with respect to host devices 135, 235, 335, 435, and 535 and/or host controllers 140, 240, 340, 440, and 540. The sender 1202a, the recipient 1202b, and/or the host 1204 may be directly or indirectly interconnected through a known or described delivery network, such as delivery networks 160, 260, 360, 460, and 560.

[0130] More specifically, the sender 1202a may include a subscriber and/or a client (e.g., client system 505), and the host 1204 may include one or more host complexes (e.g., OSP host complex 580 and/or IM host complex 590) for providing communications capabilities and coordinating the transfer of electronic and/or voice data between subscribers. The sender 1202a may access the host 1204 using any available device and/or controller. In the implementation of FIG. 12, a sender 1202a, a recipient 1202b, and a host 1204 interact according to a procedure 1200 that extends the functionality of IM by passively personalizing the buddy list of at least one of the senders 1202a and the recipient 1202b based on IM communication sessions and other types of communication sessions involving the sender 1202a and the recipient 1202b. Communication sessions other than IM sessions may include an e-mail communication session, a phone communication session (e.g., a wired or wireless phone communication session), a voice over IP (VoIP) communication session, and other types of communication sessions. Hence, the sender 1202a and/or recipient 1202b may include devices capable of enabling such alternative communication sessions (e.g., phone, VoIP, e-mail).

[0131] Initially, the sender 1202a accesses the host 1204 (step 1206). The sender 1202a designates at least one recipient 1202b with which to communicate, for example, by means other than IM (step 1208). The communication may be, for example, an e-mail, a phone conversation, or a voice over IP conversation initiated by the sender 1202a. In one implementation, when the communication is an e-mail message, the e-mail message may include header information identifying the message, the screen name and/or IP addresses of the sender 1202a and the recipient 1202b.

[0132] The sender 1202a then communicates with the recipient 1202b by transmitting a communication to the host (step 1210). The host 1204 receives the communication from the sender 1202a (step 1212) and then optionally authenticates the communication (step 1214). A server on the host 1204 may authenticate the communication by matching the screen names and/or IP addresses with those of valid subscribers stored in a look-up table (e.g., a reverse look-up table). In the event that either the sender 1202a or the recipient 1202b is not associated with a valid subscriber, the host 1204 reports an error message. The host 1204 then sends the communication to the recipient 1202b (step 1216) and the recipient 1202b receives the communication from the host (step 1218).

[0133] During a communication session, the host 1204 may moderate the communication session (step 1220). In one

implementation, a server on the host 1204 is configured to moderate a communication session between at least one sender 1202a and at least one recipient 1202b. Moderating the communication session may include managing load conditions of the host 1204 by compressing, decompressing, caching, and/or allocating resources to store and forward communications.

[0134] Moderating the communication session (step 1220) also may include updating a communication log. In general, a communication log includes an organized (e.g., chronological and/or categorized) record of communication activity (e.g., the existence or status of separate and/or successful e-mail communications, phone communication sessions, voice over IP sessions, or the connection or disconnection with the host). The communication log may be stored and maintained on the host 1204 (e.g., by database 5914 of IM host 590), the sender 1202a (e.g., by memory 272 of the sender client device), and/or the recipient 1202b (e.g., by memory 272 of the recipient client device). Entries in the communication log may be ordered, deleted, edited, and/or otherwise managed by the host 1204, the sender 1202a, and/or the recipient 1202b. For example, the host 1204 may queue, order, and arrange entries in the communication log based on time, subscribers (e.g., screen names), topic, relevance, phone number, IP address, and/or other ranking criteria.

[0135] Typically, each subscriber will have a corresponding communication log for recording communication activity of the subscriber. However, the communication log may be associated with a group of subscribers, or may simply be used to chronologically log activities of all subscribers communicating over or with the device used to maintain or store the log.

[0136] Updating the communication log (step 1220) may include deriving and/or recording identifiers (e.g., screen names, aliases, or names) of participants of the communication session, whether an IM session or session type other than an IM. The sender 1202a, the recipient 1202b, and/or the host 1204 may be configured to detect at least one identity (e.g., the screen name) associated with a communication during a communication session, for example, by parsing the header information of an e-mail. For a phone communication, a phone number of the sender 1202a and/or the recipient 1202b may be detected (e.g., from ANI information accompanying communication packets or otherwise associated with the communication session) and/or reported to the host. The phone number may be used to derive the screen names of the participants of the phone conversation.

[0137] A list of screen names for the most recent communications including communications other than instant messages may be derived from the communication log automatically (step 1222). The sender 1202a, the recipient 1202b, and/or the host 1204 may be configured to derive such a list, which may be limited by various preselection criteria such as a number (N) of communications of a selected type or of all types collectively aggregated, or a proximity in the time of the communication to the time of the display. For example, at any time, the last N different screen names with whom a particular subscriber has had a communication session may be determined from an updated communication log. The number N may be any predetermined number set according to preferences of the sender 1202a, the recipient 1202b, and/or the host 1204, or it may be user-selectable. The manner for stor-

ing and ordering the communication log may be as described above with respect to the IM log of FIG. 6.

**[0138]** After a list of N different screen names is compiled, the user profile is accessed (step 1224) and passively configured (step 1226). That is, the configuration or reconfiguration of the user profile may occur transparently to the subscriber and may require no overt action by the subscriber (e.g., selection by the subscriber). Configuration of the user profile may include the creating and/or modifying of a subscriber's user preferences such as, for example, one or more buddy lists, address book, calendar, notification settings (e.g., alerts), or any other personalized attributes associated with the subscriber.

**[0139]** In one implementation, a buddy list included in a subscriber's user profile is configured based on the updated communication log. In particular, a buddy list associated with at least one of the sender 1202a and the recipient 1202b may be configured to include a list of most recent contacts from communication sessions other than IM sessions (step 1226). The passively configured list of most recent contacts may be displayed in a user interface (step 1228).

**[0140]** As described above with respect to UI 800 of FIG. 8 and UI 900 of FIG. 9, the user interfaces may be passively configured to include a Recent Contacts group for communication sessions. The Recent Contacts group may reflect communication sessions having a type other than an IM session. For instance, a Recent Contacts group for communication sessions other than IM sessions may be included as an integrated and/or distinct subset of the Recent Contacts group that also includes recent contacts from IM sessions, it may be a separate group unto itself, or it may be further split into one or more groups based on the type of communication session with which the recent contact occurred. For example, there may be a Recent Contacts E-mail group, a Recent Contacts Phone group, and/or a Recent Contacts for Voice Over IP group, which may be displayed as subsets of or which may be substituted for the Recent Contacts group shown by FIGS. 8 and 9.

**[0141]** FIG. 13a illustrates a UI 1300 that may be passively configured and includes a Buddy List Window 1305 having a List Setup box 1310. The List Setup box 1310 includes one or more IM groups, for example, a Recent Contacts group 1312. In this example, the Recent Contacts group 1312 includes subset groups of Recent Contacts groups such as, for example, a Recent IM Contacts group 1314, a Recent E-mail Contacts group 1316, a Recent Voice Over IP Contacts group 1318, and a Recent Phone Contacts group 1320. UI 1300 also may be displayed using the Online box tab.

**[0142]** FIG. 13b illustrates a UI 1350 that may be passively configured and includes a Buddy List window 1355 having a List Setup box 1360. The List Setup box 1360 includes one or more IM groups, for example, a Recent IM Contacts group 1362, a Recent E-mail Contacts group 1364, a Recent Voice Over IP Contacts group 1366, and a Recent Phone Contacts group 1368. In this example, the IM groups are independent of a parent Recent Contacts group and instead are separate IM groups. UI 1350 also may be displayed using the Online box tab.

**[0143]** Additionally, UI 1300 of FIG. 13a and UI 1350 of FIG. 13b may be configured (e.g., passively configured) to display other types of information to a user in addition to or in substitution of that described above. In one implementation, for example, UI 1300 and UI 1350 may include information for group members other than or in addition to the screen

names for group members, such as, for example, contact information (e.g., phone numbers, e-mail addresses, and mailing addresses). The contact information may be obtained from a user profile that may be stored and maintained on the host 604 of FIG. 6 (e.g., IM host 590, database 5914), the sender 602a of FIG. 6 (e.g., client device, memory 272), and/or the recipient 602b of FIG. 6 (e.g., client device, memory 272).

**[0144]** FIG. 14 illustrates a UI 1400 that may be used to display information from the user profile and includes a Buddy List window 1405 having a List Setup box 1410. The information also may be displayed using the Online box tab. The List Setup box 1410 includes one or more groups, such as, for example, a Recent IM Contacts group 1412, a Recent E-mail Contacts group 1414, a Recent Voice Over IP Contacts group 1416, and a Recent Phone Contacts group 1418. The information displayed by each group is passively configured to include identifiers (e.g., screen names, aliases, or names) and/or other contact information (e.g., e-mail addresses, phone numbers, mailing addresses) derived from the communications log and user profile based on recent communication sessions (e.g., IM sessions, e-mail sessions, voice over IP sessions, and phone sessions).

**[0145]** The information displayed under each group may be based on the type of recent communication session that caused the information to be displayed. For example, with respect to an identity with whom communications were recently conducted or closed, whether by IM or otherwise, the Recent IM Contacts group 1412 may be passively configured to display an identifier (e.g., a screen name, alias, or name) reflecting information useful in establishing communications with entities with whom IM sessions were recently established or closed/discontinued. This information may include a screen name of the entity (e.g., if they are available online), or it may include other information reflecting contact information for session types other than IM (e.g., VoIP, e-mail, etc).

**[0146]** Similarly, for example, with respect to an identity with whom communications were recently conducted or closed, whether by e-mail or otherwise, the Recent E-mail Contacts group 1414 may be passively configured to display an identifier (e.g., screen name, alias, or name) useful in establishing communications with entities with whom e-mail sessions were recently established or closed/discontinued. This information may include an e-mail address of the entity, or it may include other information reflecting contact information for session types other than e-mail (e.g., IM, VoIP, e-mail, etc).

**[0147]** Similarly, for example, with respect to an identity with whom communications were recently conducted or closed, whether by VoIP or otherwise, the Recent Voice over IP Contacts group 1416 may be passively configured to display an identifier (e.g., screen name, alias, or name) useful in establishing communications with entities with whom VoIP sessions were recently established or closed/discontinued. This information may include information for establishing a VoIP session, or it may include other information reflecting contact information for session types other than VoIP (e.g., IM, VoIP, e-mail, etc).

**[0148]** Similarly, for example, with respect to an identity with whom communications were recently conducted or closed, whether by telephony or otherwise, the Recent Phone Contacts group 1418 may be passively configured to display an identifier (e.g., screen name, alias, or name) useful in

establishing communications with entities with whom telephony sessions were recently established or closed/discontinued. This information may include a telephone number of the identity, or it may include other information reflecting contact information for session types other than telephony (e.g., IM, VoIP, e-mail, etc).

**[0149]** The information displayed within each Contacts group may be used to initiate a communication session using one or more particular types of communications. For example, selecting (e.g., clicking) an identifier listed in the Recent IM Contacts group **1412** may invoke a pre-addressed IM window (UI **1000** of FIG. **10**) to enable an IM session. Selecting an identifier and/or an e-mail address listed in the Recent E-mail Contacts group **1414** may invoke a pre-addressed interface to send an e-mail to the recent e-mail contact and/or may invoke a pre-addressed IM window to enable an IM session. The user may be able to select the type of communication to be used or a default communication type may be selected for the user when more than one type of communication is available for an entity identified by the Recent Contacts group or one or more of the Recent Contact sub-groups or substitutes.

**[0150]** For example, if the recent e-mail contact is detected to be online, an IM communication may be selected as the default. If the IM communication is not available, for instance, because the recent e-mail contact is not online, then another communication type may be used (e.g., an e-mail communication or a phone communication). Selecting an identifier and/or the displayed Voice over IP information listed in the Recent Voice over IP Contacts group **1416** may invoke a voice over IP interface and/or initiate a voice over IP communication session with the recent voice over IP contact, and also may invoke a pre-addressed IM window to enable an IM session. Selecting an identifier and/or a phone number listed in the Recent Phone Contacts group **1418** may invoke a phone interface and/or initiate a phone communication session with the recent phone contact, and also may invoke a pre-addressed IM window to enable an IM session. Presence information may be useful in discerning which of several alternative communication schemes is available or most appropriate, and even to chose between several non-IM communication types.

**[0151]** The contact information (e.g., screen name, e-mail address, phone number, or VoIP contact information) within each group may be hidden, may be explicitly displayed or may be revealed by moving a pointing device over the information that is displayed to reveal additional information. For example, when default contact information is displayed irrespective of entity availability, the cursor may be moved over information displayed in the Recent Contacts group to reveal additional contact information, such as, for example, an e-mail address or a phone number to supplement a display that is limited to screen name. Revealing the additional information is useful when a particular communication type is not available, for example, where a screen name is displayed for an entity that is not online. When this occurs, a communication session over an alternate communication type may be established using the additional information that is explicitly displayed or revealed.

**[0152]** In one implementation, a passively configured user profile, and, thus, a passively configured subscriber buddy list including one or more types of recent contact groups, may be made accessible through any of several different devices independent of the device that was being used at the time of

the communication session that resulted in the passive addition of or status change with respect to the recent contact in one or more of the Recent Contact group types. For example, in a client-host model, the user profile and communication log may be stored at the host or at some other location centrally accessible to various client devices operable by the subscriber. Thus, the passively configured subscriber buddy list may be maintained at the host and may be made accessible to multiple different devices. Alternatively, the passively configured subscriber buddy list may be made accessible to one device and then pushed and/or pulled from device-to-device.

**[0153]** As a result, a subscriber may participate in an e-mail session with an e-mail contact using a personal computer. An identifier and/or e-mail address of the recent e-mail contact may be passively added to the subscriber Recent E-mail Contacts group. Concurrently, an identifier and/or e-mail address for that recent e-mail contact also may be reflected within the subscriber's Recent Contact group (e.g., Recent E-mail Contacts group) presented on another device (e.g., a PDA). The subscriber may select the identifier and/or e-mail address to initiate a communication session (e.g., an e-mail session or an IM session) with the recent e-mail contact from either device. Similarly, other recent contacts from all of the communication types may be presented to the user across multiple devices to enable different types of communication sessions to be initiated from one or more of the devices.

**[0154]** In one implementation, the sender **1202a** may not need to transmit the communication to the host **1204** (step **1210**) and instead may transmit the communication directly to the recipient **1202b** without sending the communication through the host **1204**. In this case, steps **1210**, **1212**, **1214**, and **1216** may be optional. In this instance, the host **1204** may be notified by the sender **1202a**, by the recipient **1202b** and/or by a third-party that a communication session other than an IM session occurred between the sender **1202a** and the recipient **1202b**. Upon such notification, the host **1204** updates a communication log for the sender **1202a** and the recipient **1202b** (step **1220**), derives identifiers for the sender **1202a** and the recipient **1202b** (step **1222**), accesses the user profile for the sender **1202a** and the recipient **1202b** (e.g., buddy list) (step **1224**), and passively configures the user profile (step **1226**) based upon the received notification. Additionally or alternatively, the sender **1202a** or the recipient **1202b** may update a communication log for the sender **1202a** and the recipient **1202b** (step **1220**), derive identifiers for the sender **1202a** and the recipient **1202b** (step **1222**), access the user profile for the sender **1202a** and the recipient **1202b** (e.g., buddy list) (step **1224**) and passively configure the user profile (step **1226**).

**[0155]** More specifically, a phone communication may take place between the sender **1202a** and the recipient **1202b** without communicating the phone conversation through the host **1204**. In this case, the host **1204** may be notified by the sender **1202a**, by the recipient **1202b**, or by a third party (e.g., a telephone carrier) that a communication session occurred between the sender **1202a** and the recipient **1202b**. The host **1204** then may update a communication log for the sender **1202a** and the recipient **1202b** (step **1220**), derive screen names for the sender **1202a** and the recipient **1202b** (step **1222**), access the user profile for the sender **1202a** and the recipient **1202b** (e.g., buddy list) (step **1224**) and passively configure the user profile (step **1226**) based upon the received notification.

**[0156]** A number of implementations have been described. Nevertheless, it will be understood that various modifications may be made. In other implementations, for example, other groups (e.g., Frequent Contacts, Popular Contacts) may be passively created and maintained in a persistent state in order to facilitate instant messaging. In yet other implementations, for example, other groups and lists may be passively created and maintained in a persistent state in order to facilitate instant messaging. These other groups and lists may include instant messages received; knock-knocks received (i.e., instant messages received from unknown identities), but accepted and/or declined; instant messages sent without receiving a response; instant messages sent to Buddies; instant messages sent to non-Buddies; IM sessions where at least a threshold number of messages have been exchanged; and instant messages received to the exclusion of knock-knocks.

**[0157]** Other implementations are within the scope of the following claims.

What is claimed is:

1. A method of personalizing communications for a first communication platform, the method comprising:
  - accessing status information for communication sessions by a communication identity that leverage a first communication platform other than an instant messaging platform; and
  - passively configuring a participant list associated with the communication identity and the first communication platform to persistently reflect a list of participant identities from communication sessions in which the communication identity recently participated to using the communication platform.

\* \* \* \* \*