



US 20080114280A1

(19) **United States**
(12) **Patent Application Publication**
Stafford

(10) **Pub. No.: US 2008/0114280 A1**
(43) **Pub. Date: May 15, 2008**

(54) **VARIABLE SPEED SENSOR INSERTION DEVICES AND METHODS OF USE**

Publication Classification

(76) Inventor: **Gary Ashley Stafford, Hayward, CA (US)**

(51) **Int. Cl.**
A61N 1/30 (2006.01)
(52) **U.S. Cl.** **604/19**

(57) **ABSTRACT**

Correspondence Address:
JACKSON & CO., LLP
6114 LA SALLE AVENUE, #507
OAKLAND, CA 94611-2802

An automatic sensor inserter is disclosed for placing a transcutaneous sensor into the skin of a living body. According to aspects of the invention, characteristics of the insertion such as sensor insertion speed may be varied by a user. In some embodiments, insertion speed may be varied by changing an amount of drive spring compression. The amount of spring compression may be selected from a continuous range of settings and/or it may be selected from a finite number of discrete settings. Methods associated with the use of the automatic inserter are also covered.

(21) Appl. No.: **11/552,072**

(22) Filed: **Oct. 23, 2006**

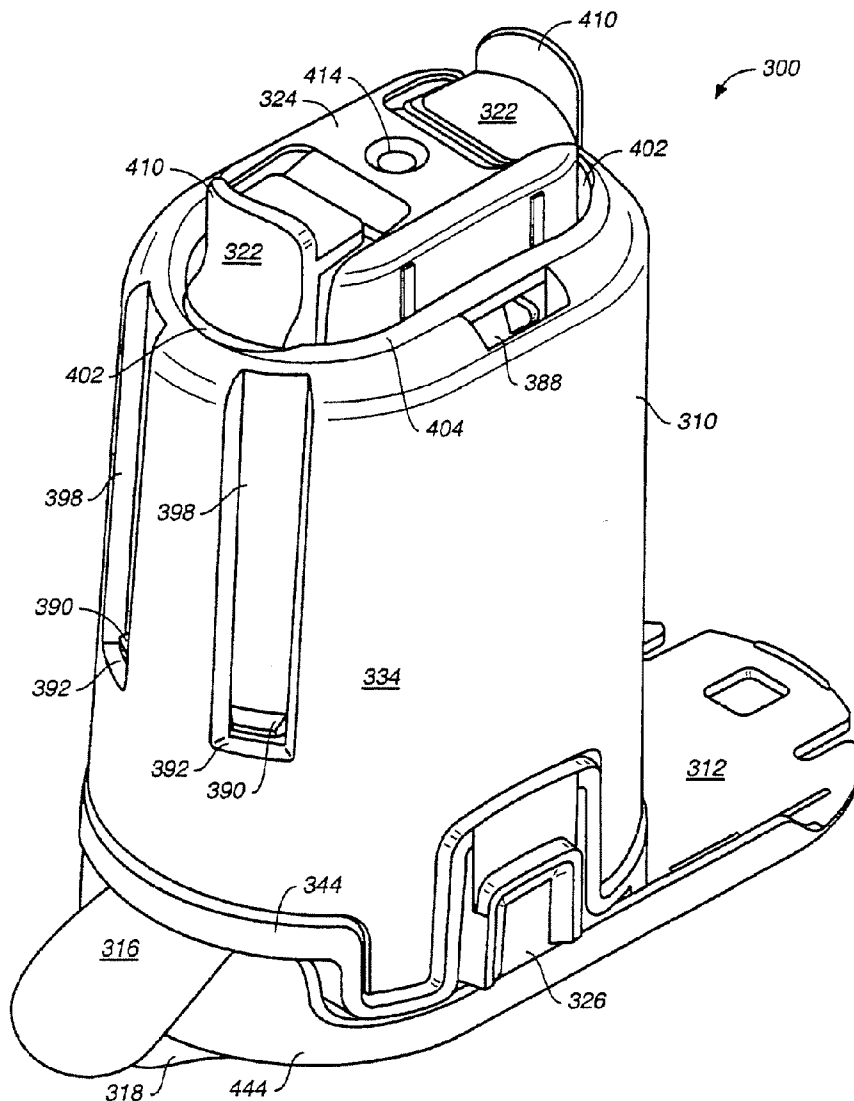

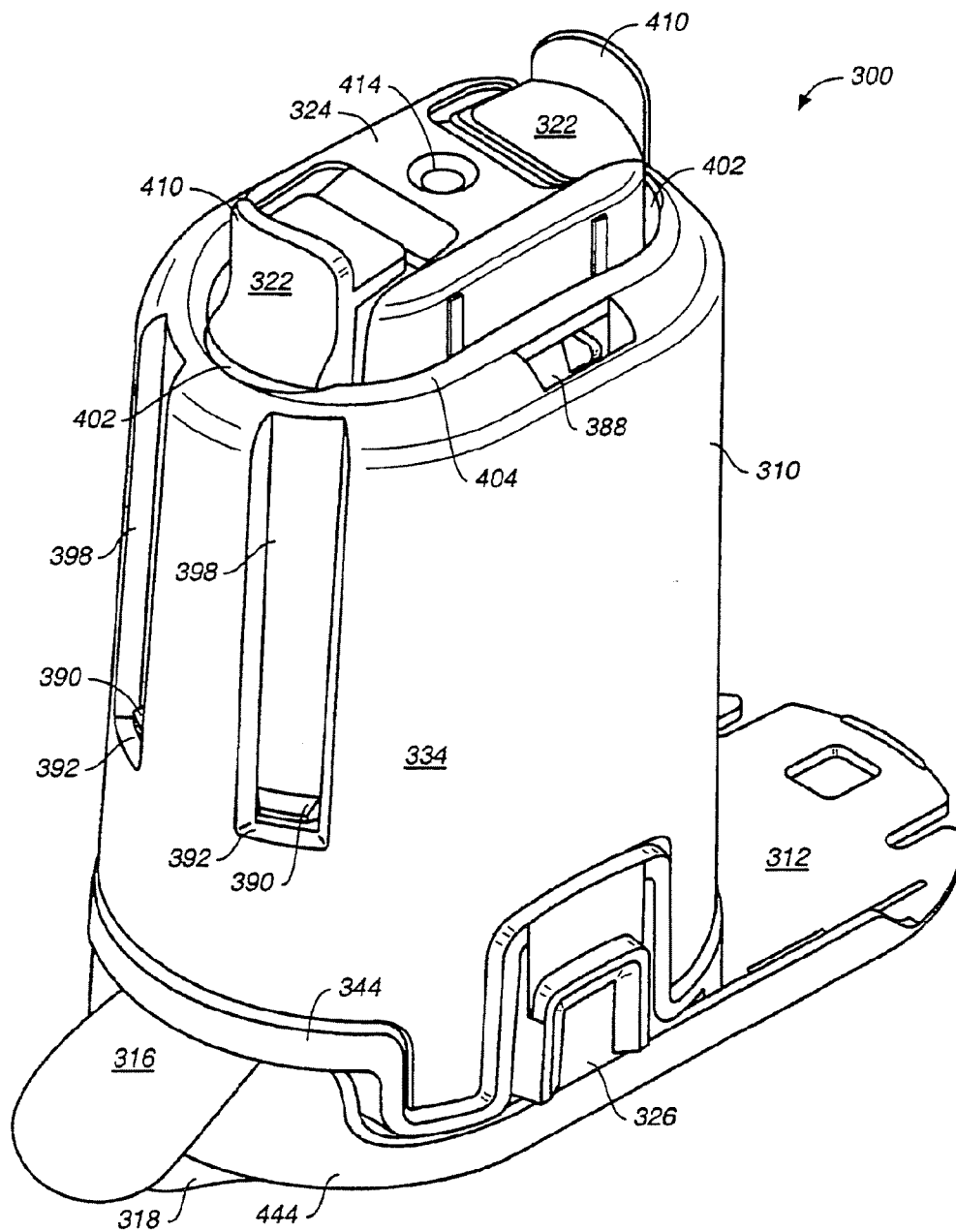

FIG. 1

FIG. 2

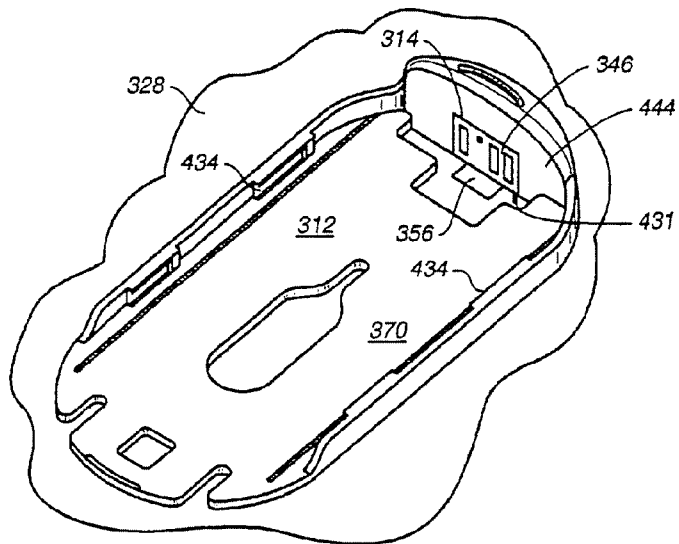

FIG. 3

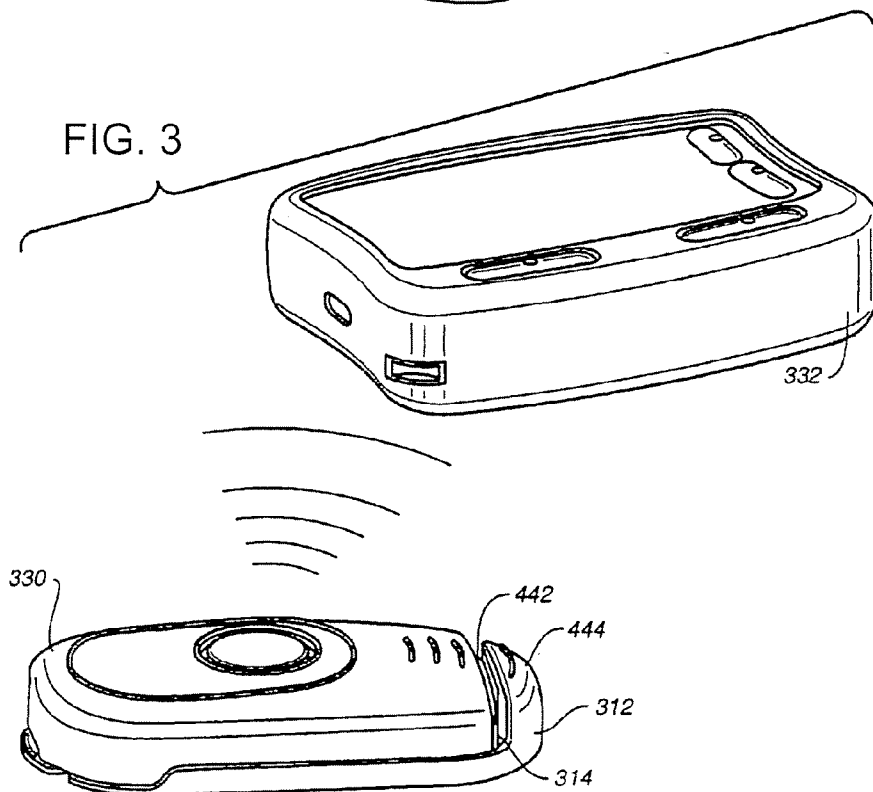
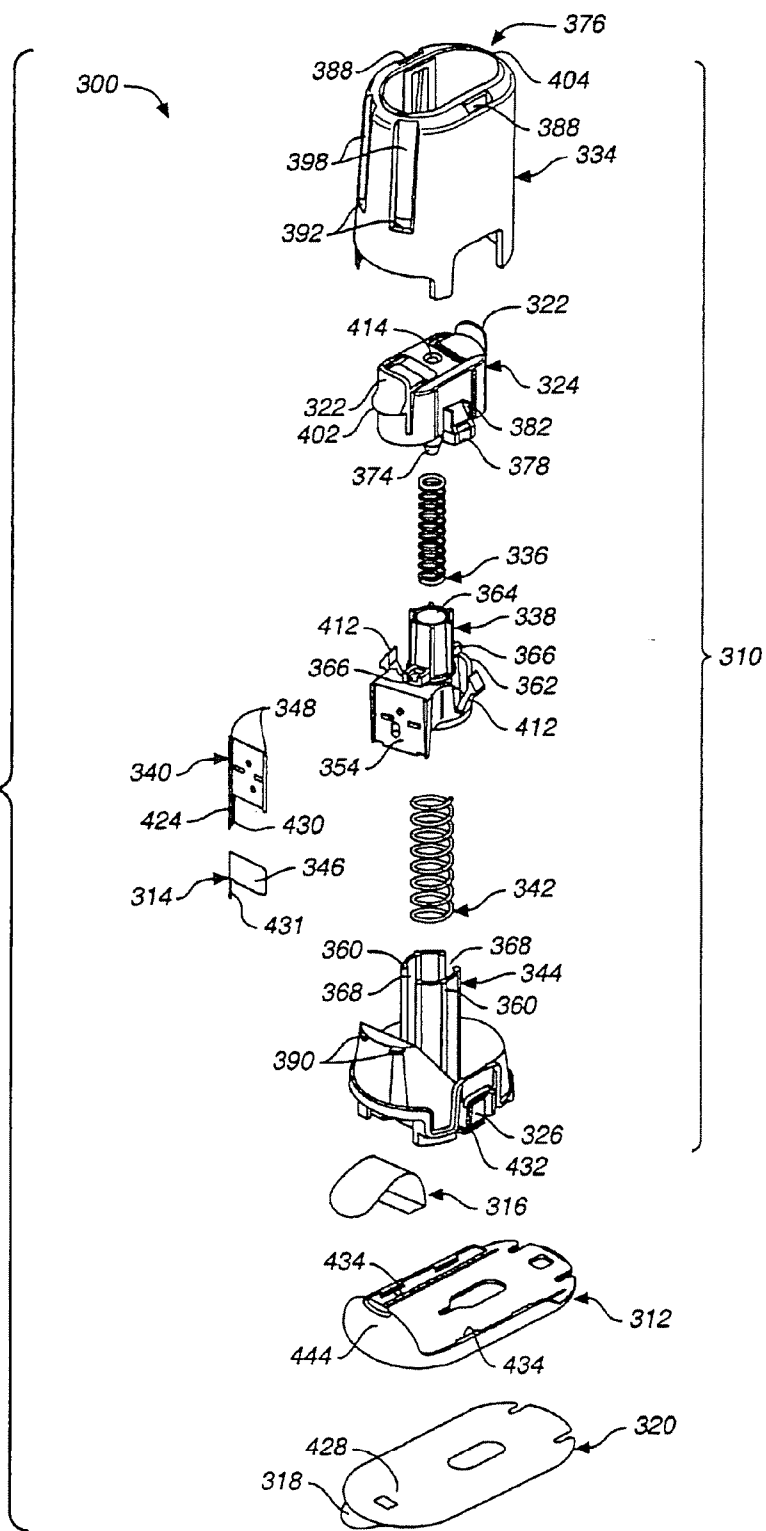

FIG. 4



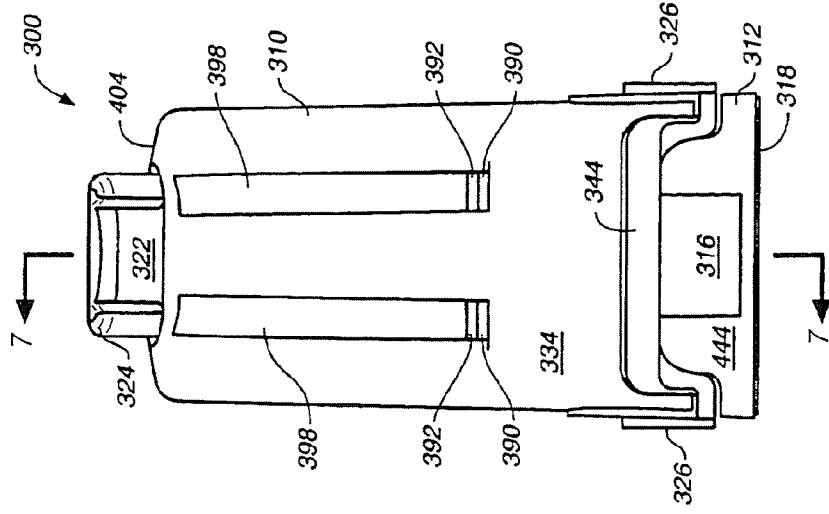

FIG. 5

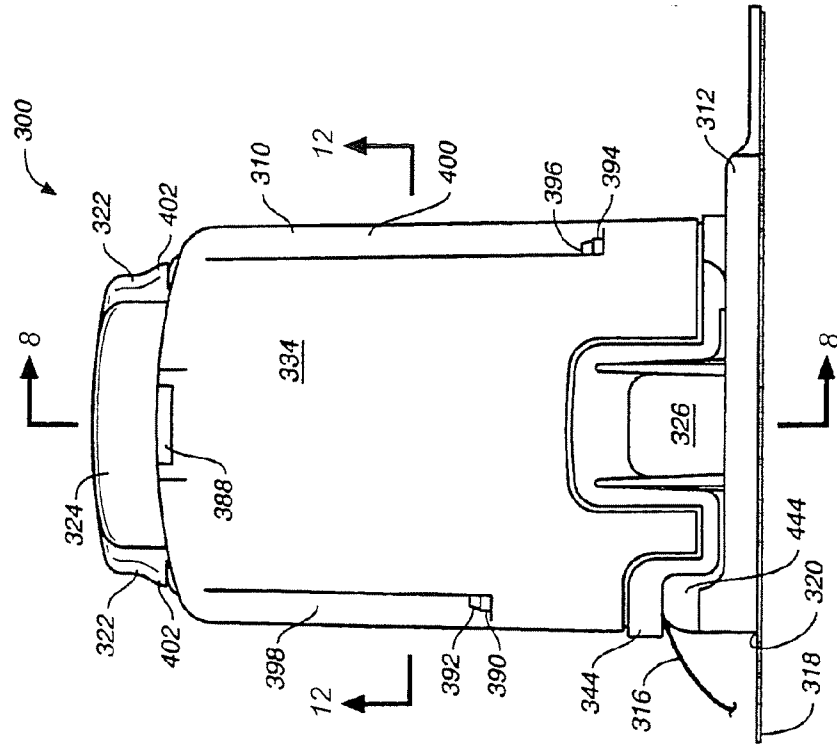
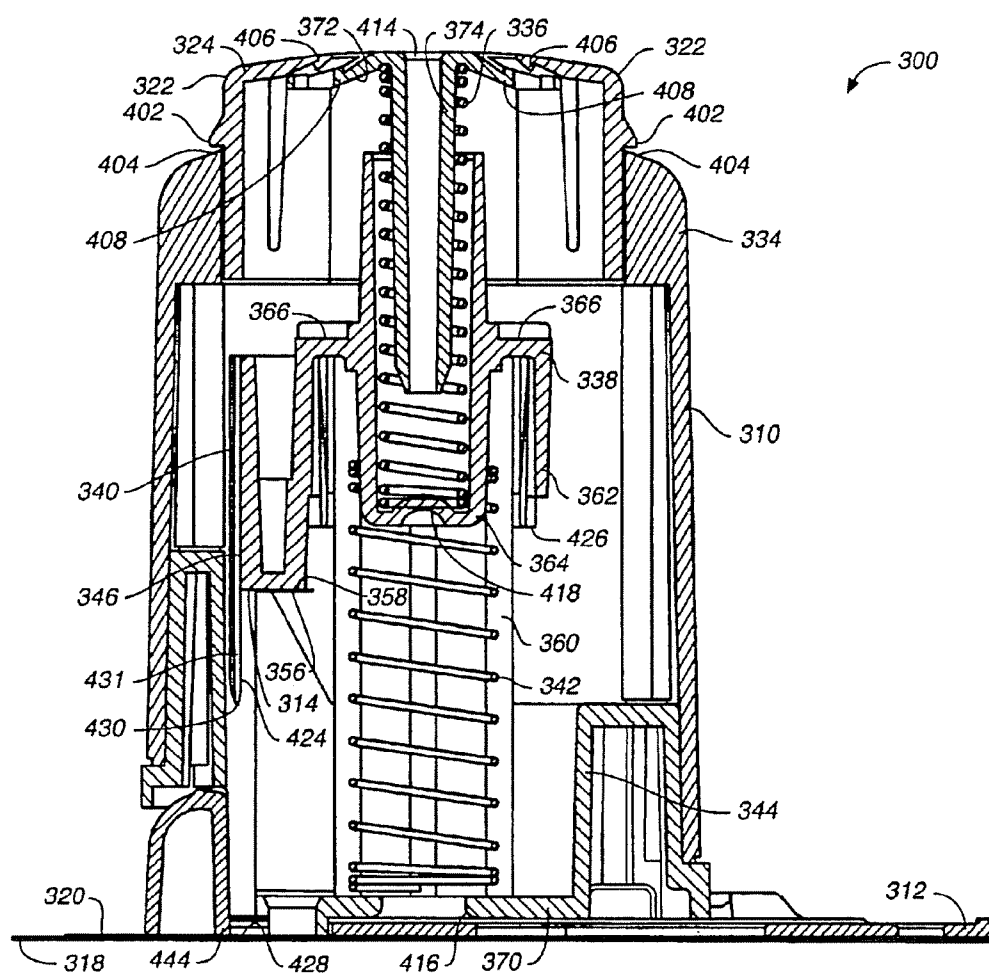

FIG. 6

FIG. 7



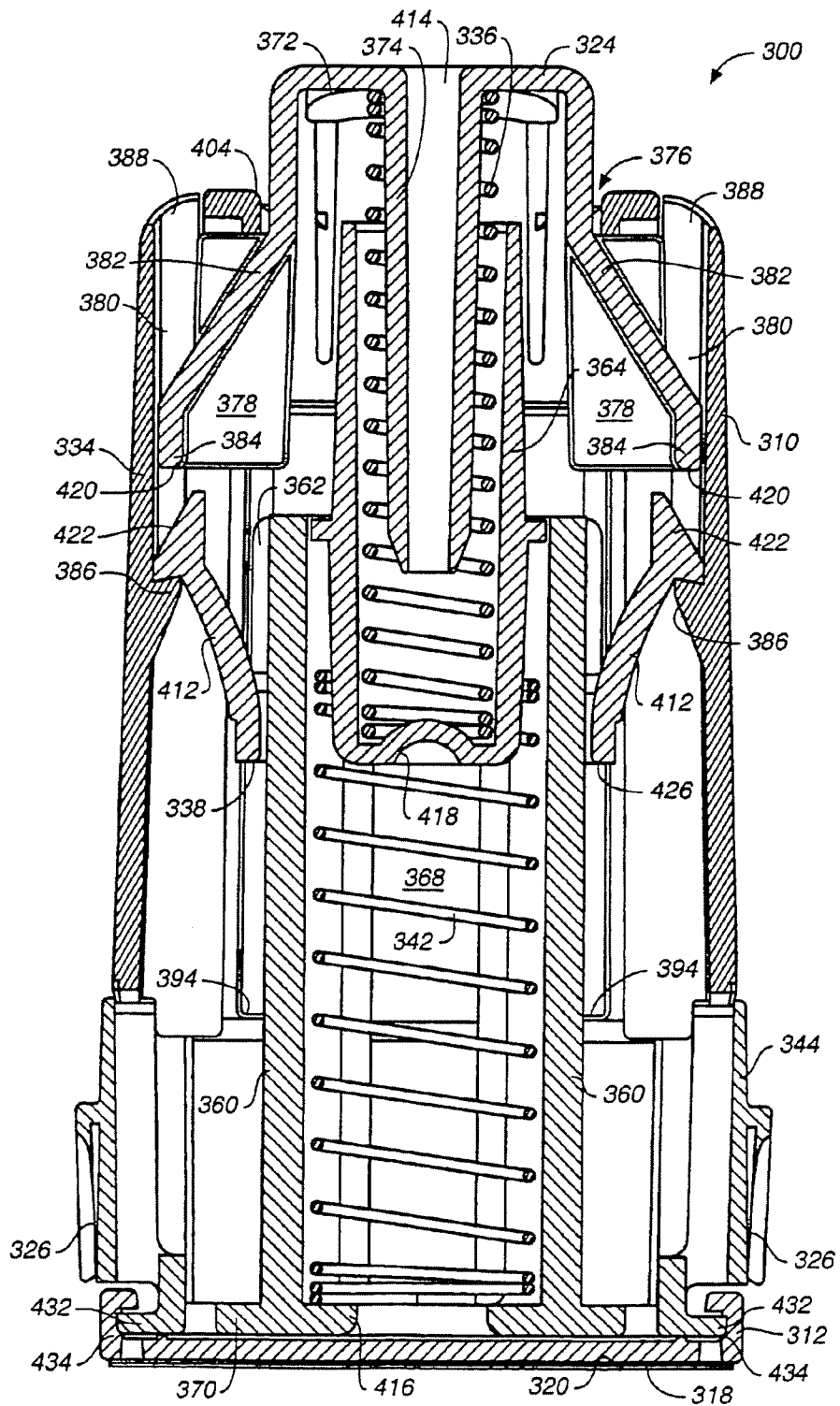

FIG. 8

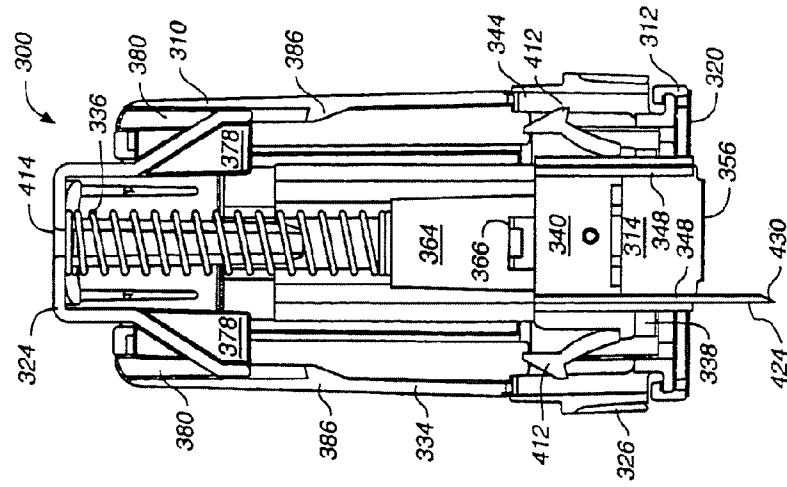

FIG. 9

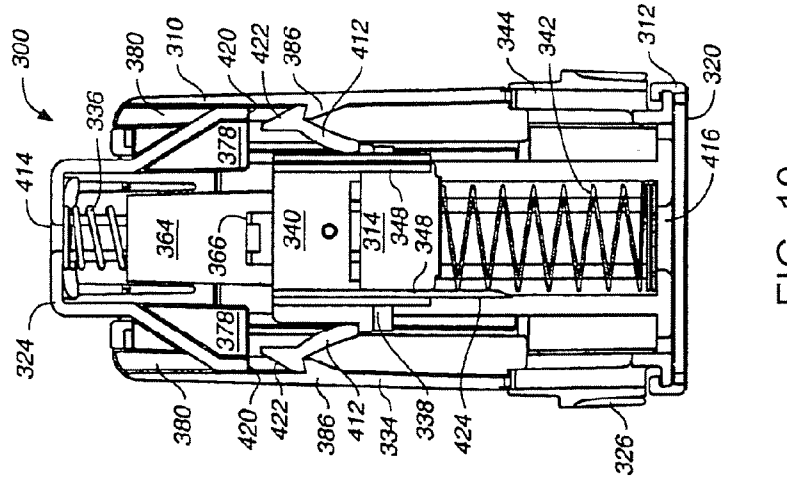

FIG. 10

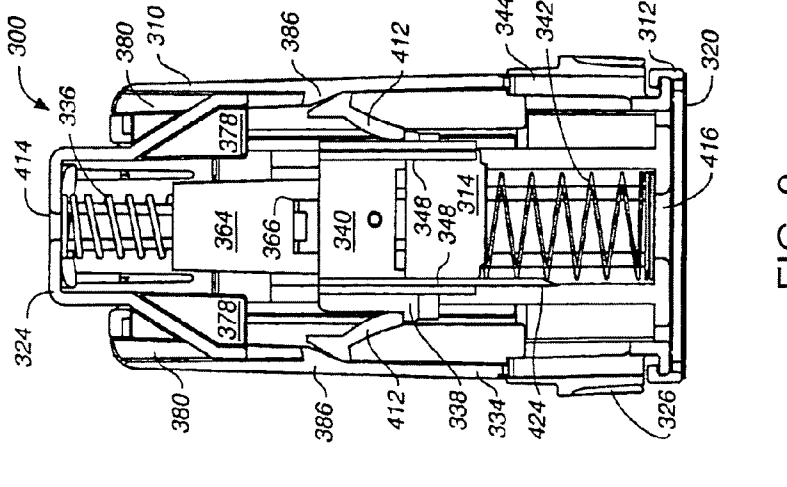

FIG. 11

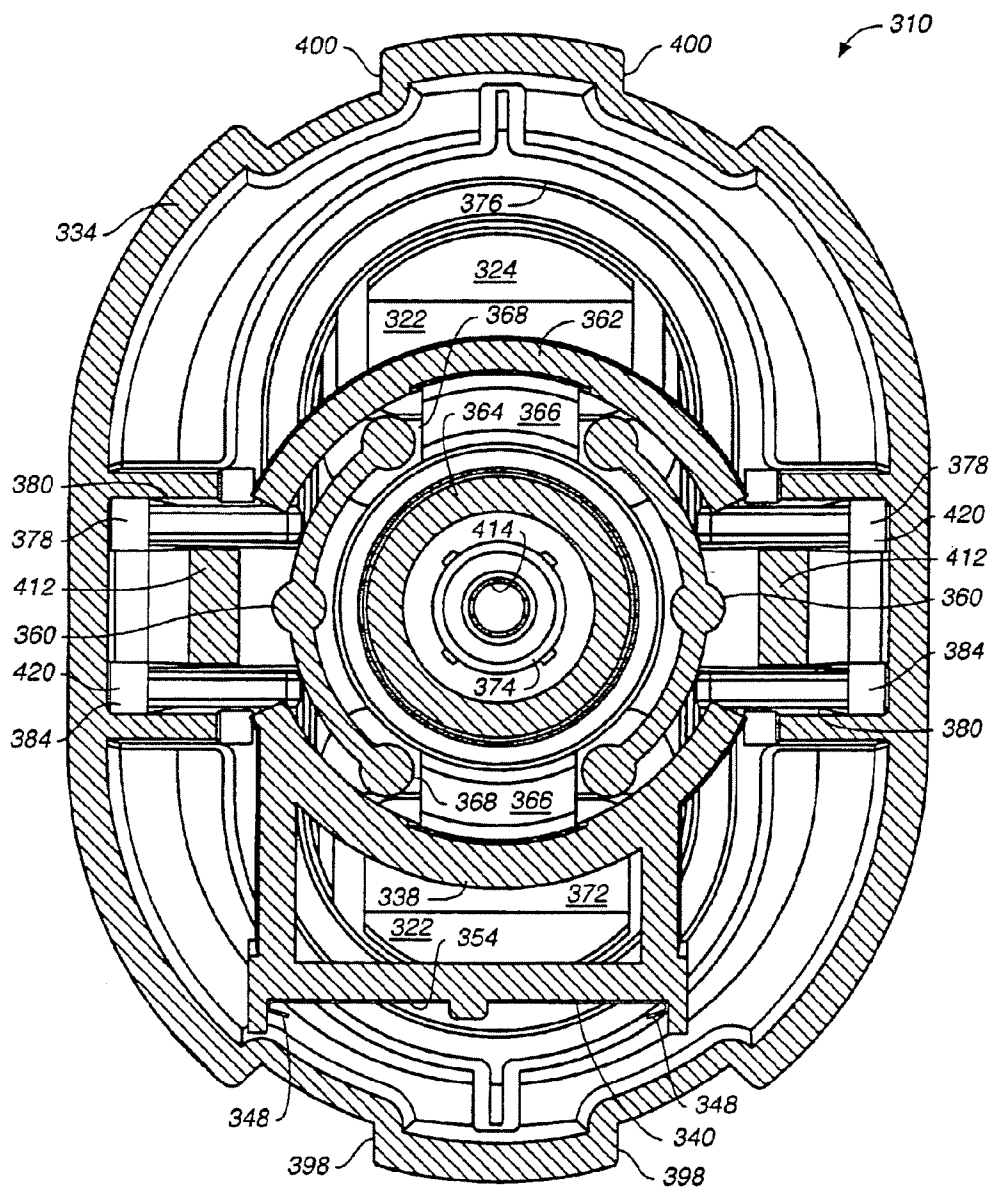

FIG. 12

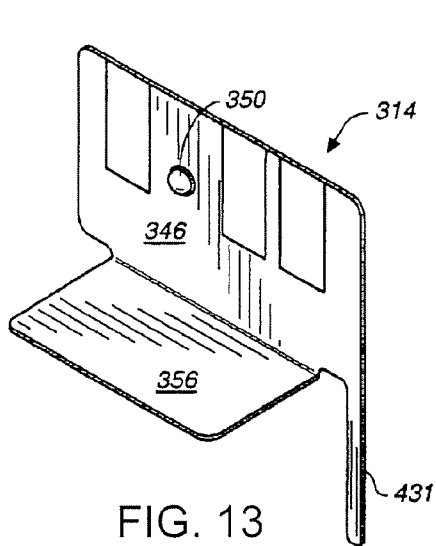

FIG. 13

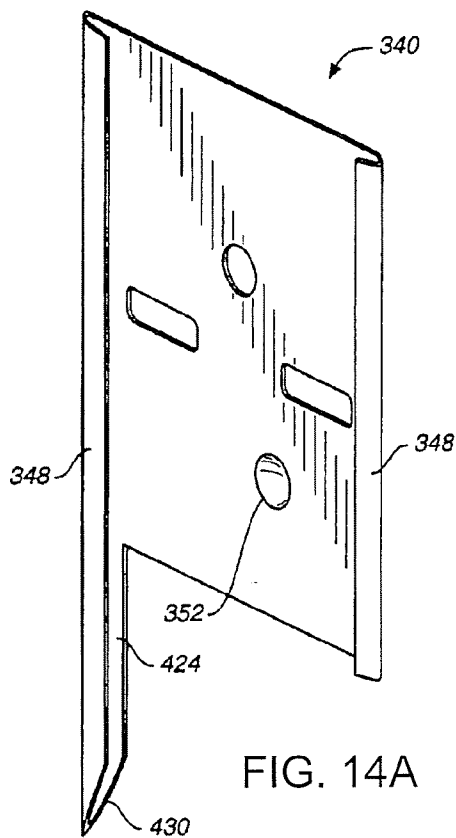

FIG. 14A

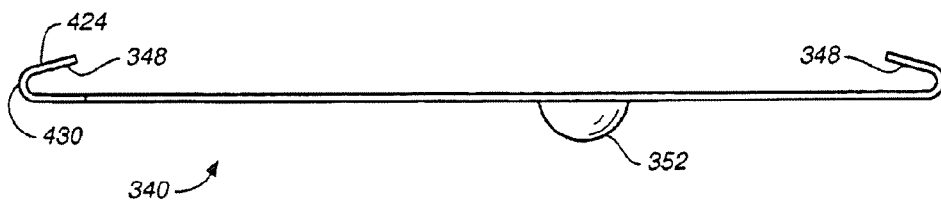
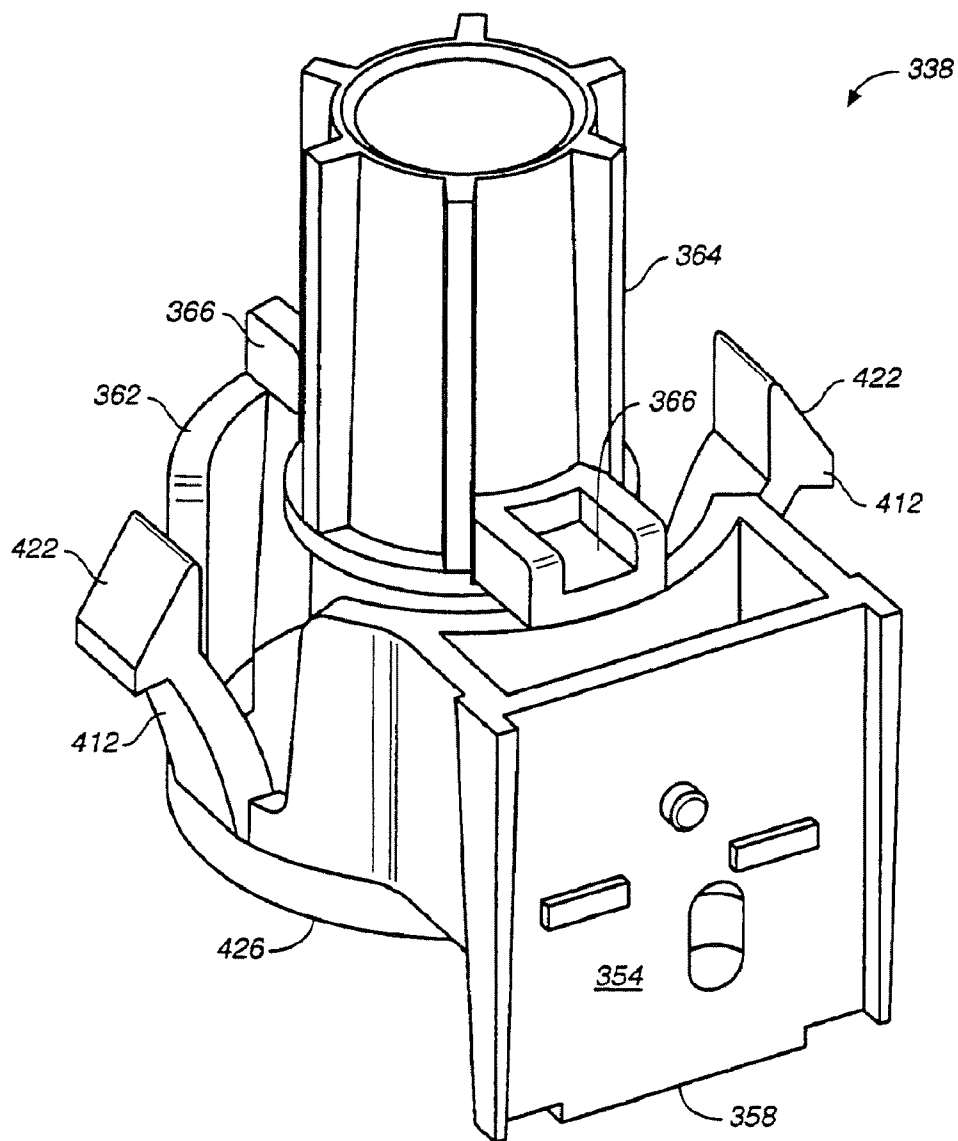

FIG. 14B

FIG. 15



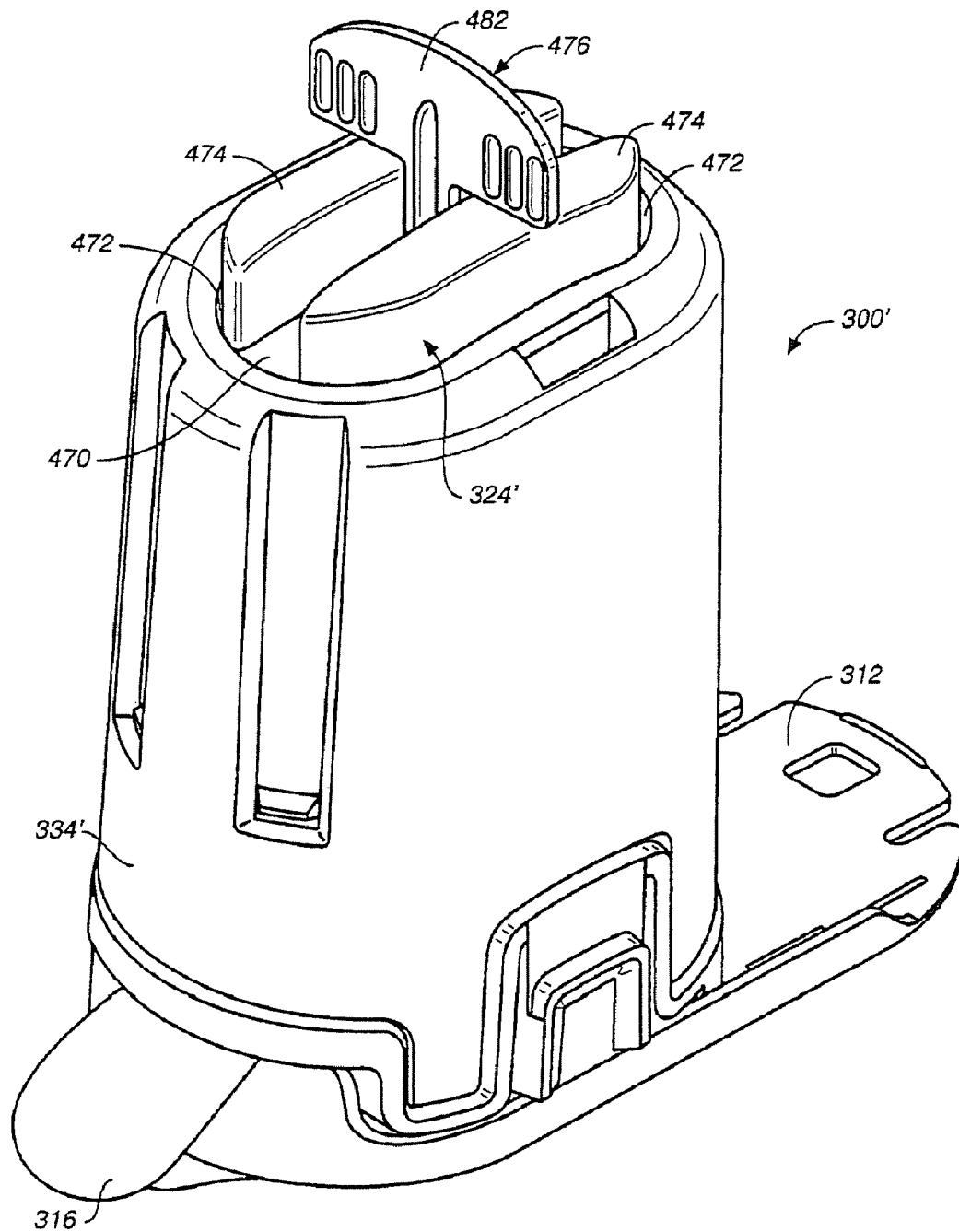

FIG. 16A

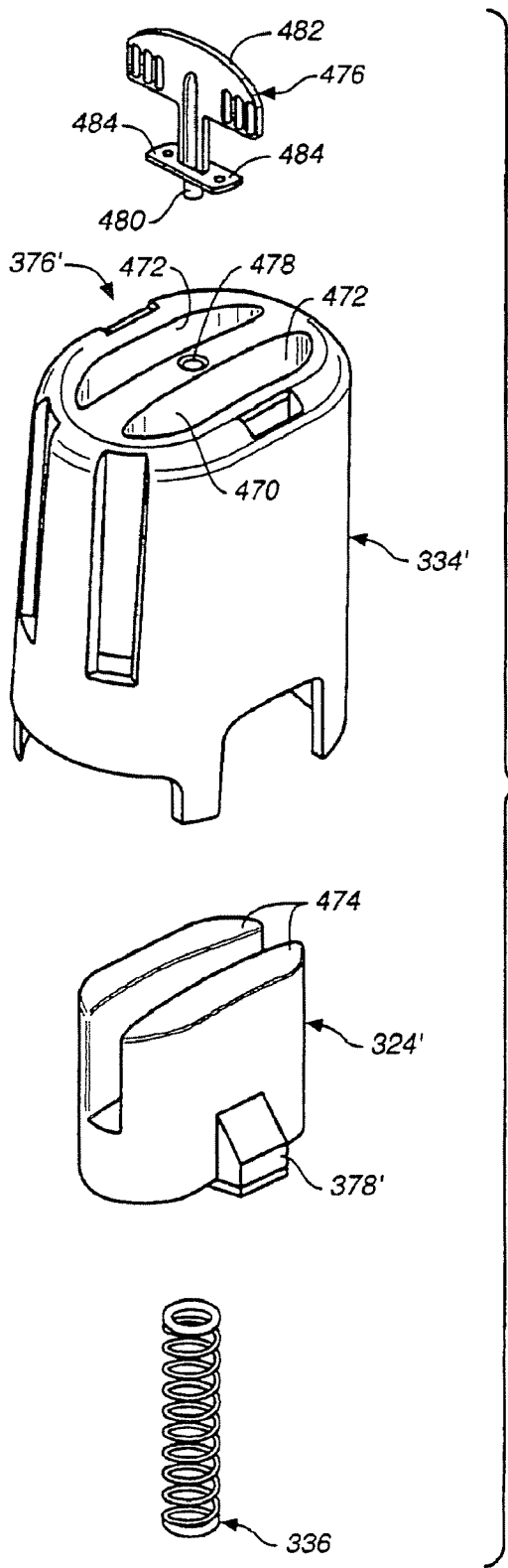

FIG. 16B

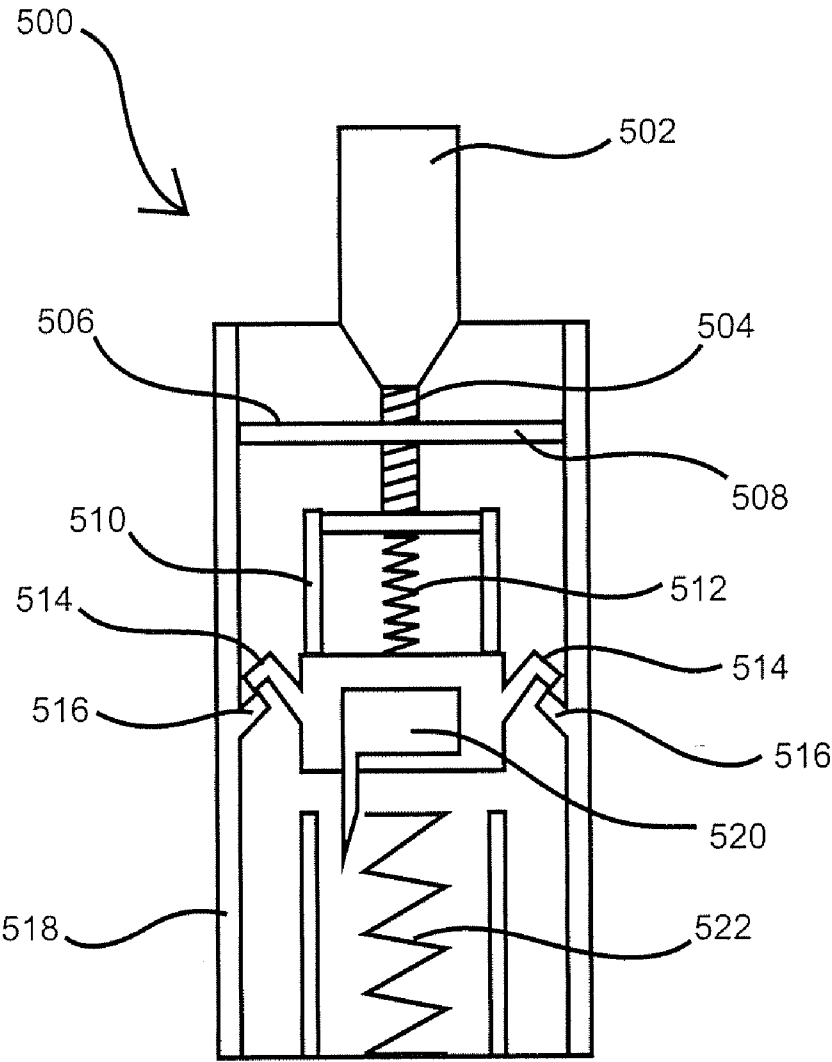

FIG. 17

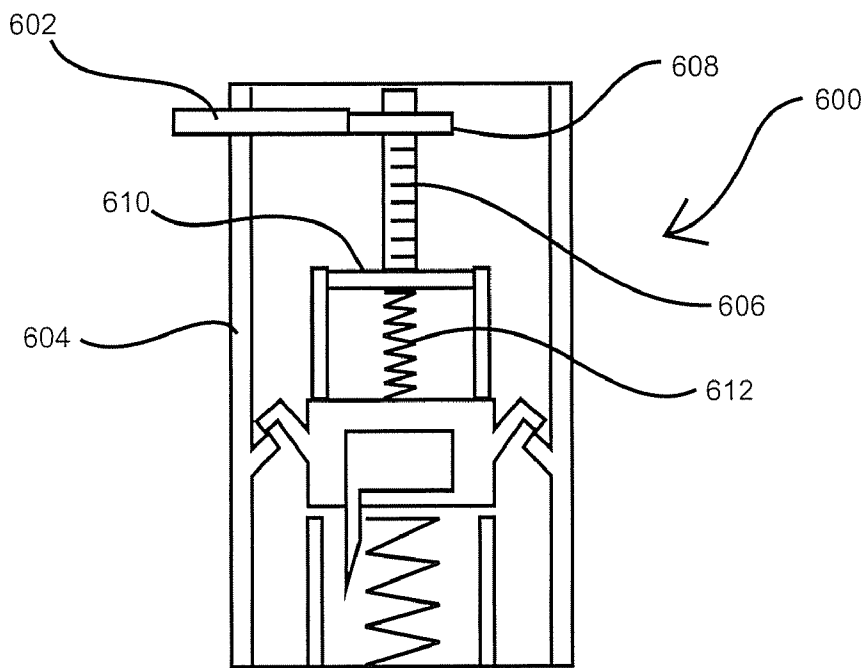

FIG. 18A

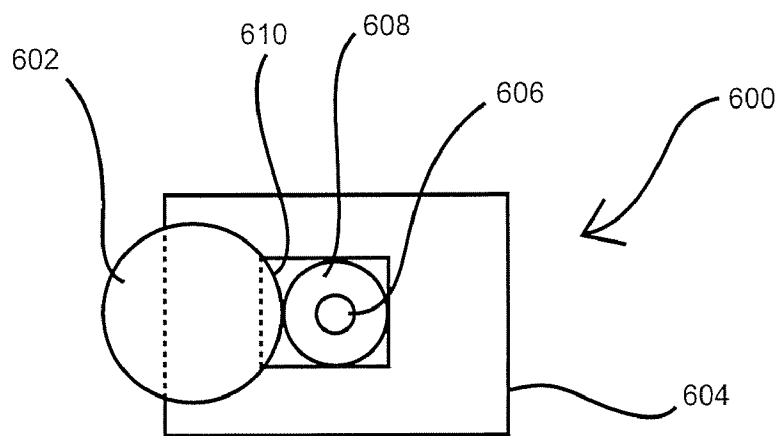

FIG. 18B

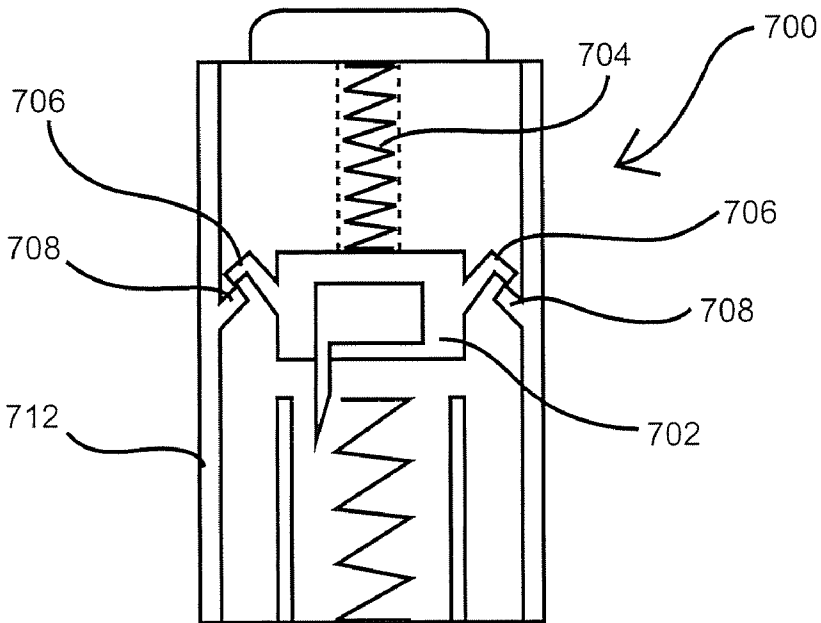

FIG. 19A

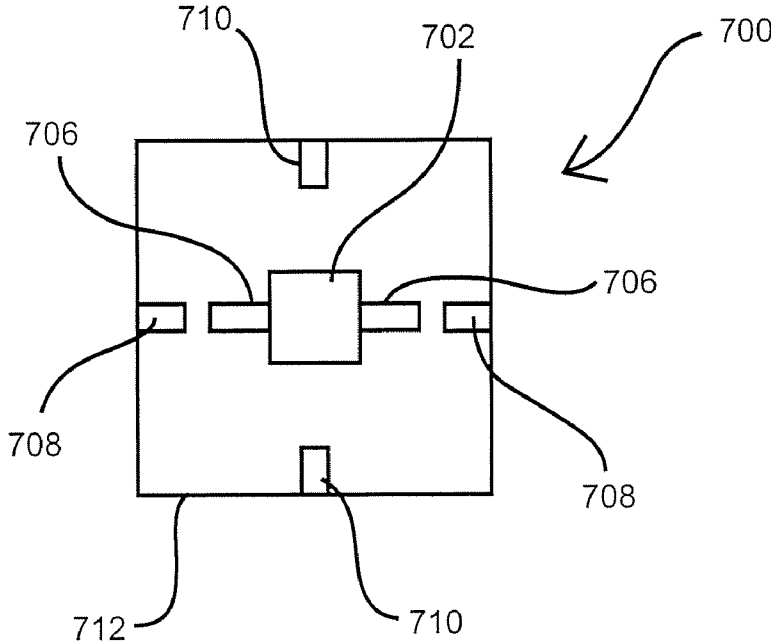

FIG. 19B

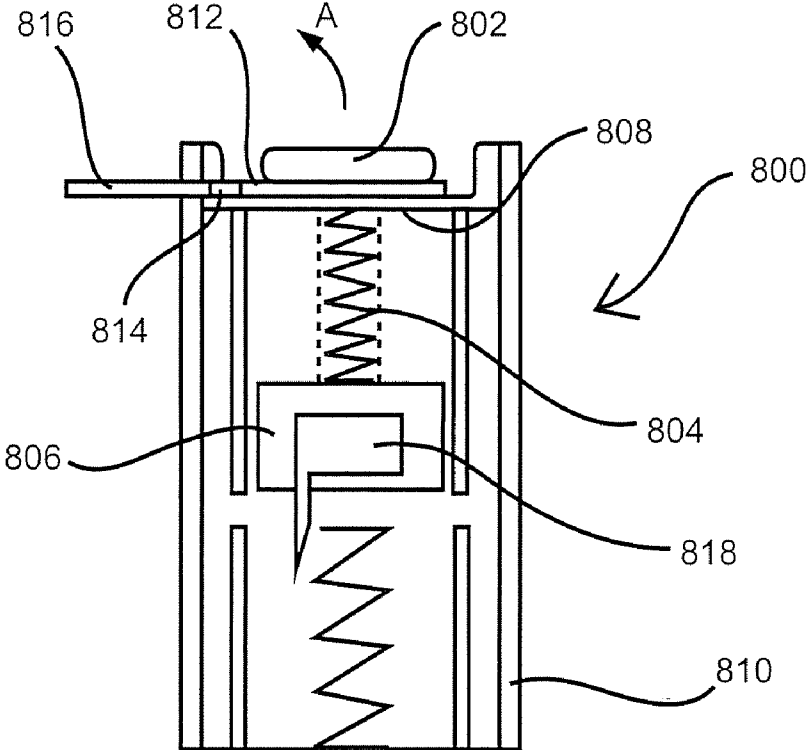

FIG. 20A

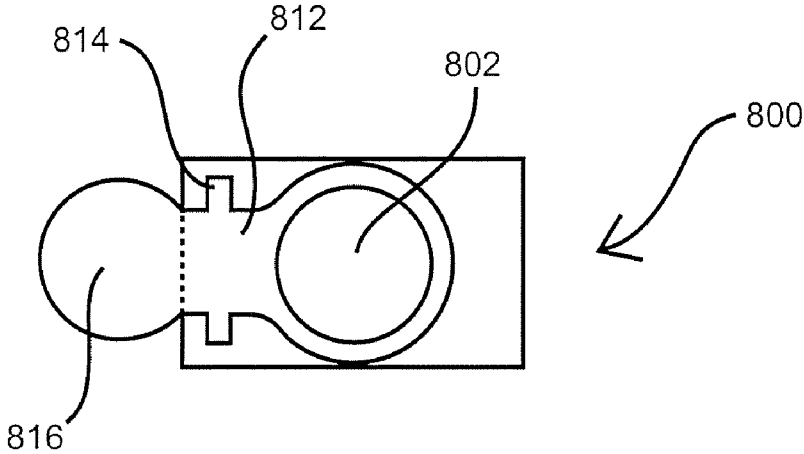

FIG. 20B

VARIABLE SPEED SENSOR INSERTION DEVICES AND METHODS OF USE

FIELD OF THE INVENTION

[0001] The present invention relates to medical devices for monitoring analytes in a living body, such as monitoring glucose levels in people with diabetes. More particularly, the invention relates to automatic devices for inserting analyte sensors into the skin of a patient.

BACKGROUND OF THE INVENTION

[0002] In recent years, people with diabetes have typically measured their blood glucose level by lancing a finger tip or other body location to draw blood, applying the blood to a disposable test strip in a hand-held meter and allowing the meter and strip to perform an electrochemical test of the blood to determine the current glucose concentration. Such discrete, in vitro testing is typically conducted at least several times per day. Continuous in vivo glucose monitoring devices are currently being developed to replace in vitro devices. Some of these continuous systems employ a disposable, transcutaneous sensor that is inserted into the skin to measure glucose concentrations in interstitial fluid. A portion of the sensor protrudes from the skin and is coupled with a durable controller and transmitter unit that is attached to the skin with adhesive. A wireless handheld unit is used in combination with the skin-mounted transmitter and sensor to receive glucose readings periodically, such as once a minute. Every three, five or seven days, the disposable sensor is removed and replaced with a fresh sensor which is again coupled to the reusable controller and transmitter unit. With this arrangement, a person with diabetes may continuously monitor their glucose level with the handheld unit. Detailed descriptions of such a continuous glucose monitoring system and its use are provided in U.S. Pat. No. 6,175,752, issued to TheraSense, Inc. on Jan. 16, 2001, which is incorporated by reference herein in its entirety.

[0003] Transcutaneous analyte sensors may be inserted into the user's skin using an automatic introducer or inserter device, such as those described in U.S. patent application Ser. No. 10/703,214, published Jul. 8, 2004 under publication number 20040133164, incorporated herein by reference in its entirety. Most sensor inserter devices described in the above published patent application have two springs, one for driving an introducer sharp and a sensor into the skin of a patient, and another for retracting the introducer sharp, leaving the sensor behind in the patient's skin. The spring arrangements are chosen to provide an introducer sharp and sensor speed optimized to insert the sensor into a typical patient.

SUMMARY OF THE INVENTION

[0004] According to aspects of some embodiments of the present invention, it is recognized that a sensor introducer having variable insertion speeds, insertion forces, travel distances, accelerations and/or other characteristics of sensor insertion that may be adjusted for different situations and/or different patients may be desirable. For example, due to physiological factors and trauma that may result from high speed automatic insertion of an analyte sensor, there may be a need to slow down and control the velocity of the puncturing apparatus. In other situations, such as for patients with different skin characteristics such as higher than aver-

age skin thickness and/or skin density, it may be desirable to speed up the velocity of the puncturing device. Alternatively, situations involving inserting sensors into different locations on a patient, such as the arm, torso or thigh, may benefit from the use of a single inserter or single inserter type with a sensor insertion velocity that may be sped up or slowed down. According to other aspects of the invention, a single inserter type may be configured to alternately insert different types sensors and/or other devices, in which case an insertion setting may be set depending on which type of sensor or device is currently being inserted.

[0005] According to other aspects of the invention, a sensor insertion device may be provided with an adjustable feature allowing a user to adjust the sensor insertion speed prior to use.

[0006] According to other aspects of the invention, a sensor insertion device may be provided with an adjustment feature allowing the insertion speed to be variably adjusted over a range of velocities.

[0007] According to other aspects of the invention, a sensor insertion device may be provided with an adjustment feature allowing the insertion speed to be selected from among a finite number of discrete settings.

[0008] According to other aspects of the invention, a sensor insertion device may be provided with an adjustment feature allowing the insertion speed to be adjusted by changing the amount of compression of a drive spring. In one embodiment, a spring compression may be adjusted by using a knob. In another embodiment, a spring compression may be adjusted by turning a thumbwheel. In another embodiment, a spring compression may be adjusted by changing the orientation of a component of the inserter. In another embodiment, a spring compression may be adjusted by using one or more magnets.

[0009] Various analytes may be monitored by sensors inserted into a patient according to aspects of the present invention. These analytes may include but are not limited to lactate, acetyl choline, amylase, bilirubin, cholesterol, chorionic gonadotropin, creatine kinase (e.g., CK-MB), creatine, DNA, fructosamine, glucose, glutamine, growth hormones, hematocrit, hemoglobin (e.g. HbA1c), honnones, ketones, lactate, oxygen, peroxide, prostate-specific antigen, prothrombin, RNA, thyroid stimulating hormone, and troponin, in samples of body fluid. Monitoring systems may also be configured to determine the concentration of drugs, such as, for example, antibiotics (e.g., gentamicin, vancomycin, and the like), digitoxin, digoxin, drugs of abuse, theophylline, warfarin and the like. Such analytes may be monitored in blood, interstitial fluid and other bodily fluids.

[0010] In certain embodiments, other types of sensors may be inserted into a body using an inserter constructed according to aspects of the present invention. Such sensors may include but are not limited to devices for measuring physiologic parameters such temperatures, pressures, respiration, pulse, movement and electrical signals, through means such as mechanical, chemical, electrical, optical or otherwise. In addition to or instead of inserting a sensor(s) into a body, an inserter constructed according to aspects of the present

invention may insert medicine, fluid delivery devices such as infusion sets, cannulas or needles, or other medical devices.

BRIEF DESCRIPTION OF THE DRAWINGS

[0011] Each of the figures diagrammatically illustrates aspects of the invention. Of these:

[0012] FIG. 1 is a perspective view showing an exemplary embodiment of a sensor inserter and adhesive mount constructed according to aspects of the present invention.

[0013] FIG. 2 is a perspective view of an adhesive mount and sensor attached to a patient's skin.

[0014] FIG. 3 is a perspective view of a transmitter attached to an adhesive mount and transmitting to a hand-held receiver.

[0015] FIG. 4 is an exploded perspective view of the embodiment shown in FIG. 1.

[0016] FIG. 5 is a side elevation view of the embodiment shown in FIG. 1.

[0017] FIG. 6 is an end elevation view of the embodiment shown in FIG. 1.

[0018] FIG. 7 is a cross-sectional view taken along line 7-7 in FIG. 6.

[0019] FIG. 8 is a cross-sectional view taken along line 8-8 in FIG. 5.

[0020] FIG. 9 is a broken away view similar to FIG. 8, showing a shuttle in a neutral position.

[0021] FIG. 10 is a broken away view similar to FIG. 8, showing a shuttle in a cocked position.

[0022] FIG. 11 is a broken away view similar to FIG. 8, showing a shuttle in an insertion position.

[0023] FIG. 12 is a cross-sectional view taken along line 12-12 in FIG. 5.

[0024] FIG. 13 is a perspective view of a transcutaneously implantable sensor.

[0025] FIG. 14A is a perspective view of a sensor introducer.

[0026] FIG. 14B is a bottom view of the introducer shown in FIG. 14A.

[0027] FIG. 15 is a perspective view of a shuttle member.

[0028] FIG. 16A is a perspective view of an alternative embodiment of a sensor inserter kit.

[0029] FIG. 16B is an exploded view of some of the components shown assembled in FIG. 16A.

[0030] FIG. 17 is a side elevation view schematically showing an alternative embodiment of a sensor inserter.

[0031] FIG. 18A is a side elevation view schematically showing an alternative embodiment of a sensor inserter.

[0032] FIG. 18B is a top view schematically showing the sensor inserter of FIG. 18A.

[0033] FIG. 19A is a side elevation view schematically showing an alternative embodiment of a sensor inserter.

[0034] FIG. 19B is a top view schematically showing the sensor inserter of FIG. 19A.

[0035] FIG. 20A is a side elevation view schematically showing an alternative embodiment of a sensor inserter.

[0036] FIG. 20B is a top view schematically showing the sensor inserter of FIG. 20A.

[0037] Variation of the invention from that shown in the figures is contemplated.

DETAILED DESCRIPTION

[0038] The following description focuses on several variations of the present invention. The variations of the invention are to be taken as non-limiting examples. It is to be understood that the invention is not limited to particular variation(s) set forth and may, of course, vary. Changes may be made to the invention described and equivalents may be substituted (both presently known and future-developed) without departing from the true spirit and scope of the invention. In addition, modifications may be made to adapt a particular situation, material, composition of matter, process, process act(s) or step(s) to the objective(s), spirit or scope of the present invention.

[0039] Referring to FIGS. 1-20, exemplary embodiments of a sensor inserter constructed according to some aspects of the invention will be described. FIG. 1 shows an overall perspective view of a sensor inserter kit 300 comprising a single-use sensor inserter 310 and a single-use adhesive mount 312 removably attached to the bottom thereof.

[0040] As an overview of the operation of this embodiment of an inserter kit 300, the kit may come packaged generally as shown in FIG. 1 with a sensor 314 (best seen in FIGS. 4 and 25) preloaded within inserter 310 and with inserter 310 in a "cocked" state. After preparing an insertion site on the skin, typically in the abdominal region, the patient may remove an upper liner 316 and a lower liner 318 from adhesive mount 312 to expose the bottom surface and a portion of the top surface of an adhesive tape 320 (best seen in FIG. 4) located beneath mount 312. Mount 312, with inserter 310 attached, may then be applied to the patient's skin at the insertion site. Safety lock tabs 322 may be squeezed together to allow actuator button 324 to be pressed causing inserter 310 to fire, thereby inserting sensor 314 into the patient's skin with a predetermined velocity and force. Once sensor 314 has been inserted into the skin, the patient may remove inserter 310 from mount 312 by pressing release tabs 326 on opposite sides of inserter 310 and lifting inserter 310 away from mount 312.

[0041] Referring to FIG. 2, mount 312 is shown adhered to a patient's skin 328 with sensor 314 already inserted, according to this exemplary embodiment. Once inserter 310 is removed from mount 312, transmitter 330 may be slid into place. The circuitry of transmitter 330 may then make electrical contact with the contact pads on sensor 314 after transmitter 330 is fully seated on mount 312. Once initialization and synchronization procedures are completed, electrochemical measurements from sensor 314 may be sent wirelessly from transmitter 330 to a portable receiver 332, as shown in FIG. 3. Sensor 314, mount 312 and transmitter 330 may remain in place on the patient for a predetermined period, such as three, five or seven days. These components may then be removed so that sensor 314 and mount 312 may be properly discarded. The entire procedure above may then be repeated with a new inserter 310, sensor 314 and mount 312, reusing transmitter 330 and receiver 332.

[0042] Referring to FIG. 4, inserter kit 300 may be assembled as shown from the following components: housing 334, actuator button 324, drive spring 336, shuttle 338, introducer sharp 340, sensor 314, retraction spring 342, inserter base 344, upper liner 316, adhesive mount 312, adhesive tape 320, and lower liner 318.

[0043] Sensor 314 may have a main surface 346 slidably mounted between U-shaped rails 348 of introducer sharp 340 and releasably retained there by sensor dimple 350 which engages introducer dimple 352. Introducer sharp 340 may be mounted to face 354 of shuttle 338, such as with adhesive, heat stake or ultrasonic weld. Sensor 314 may also have a surface 356 that extends orthogonally from main surface 346 and just beneath a driving surface 358 of shuttle 338 when mounted thereon (details of these features are better shown in FIGS. 7 and 13-15.)

[0044] Shuttle 338 may be slidably and non-rotatably constrained on base 344 by arcuate guides 360. As best seen in FIGS. 7, 12 and 15, shuttle 338 may be generally formed by an outer ring 362 and an inner cup-shaped post 364 connected by two bridges 366. Bridges 366 slide between the two slots 368 formed between guides 360 and allow shuttle 338 to travel along guides 360 without rotating. Retraction spring 342 may be captivated at its outer circumference by guides 360, at its bottom by the floor 370 of base 344, at its top by bridges 366, and/or at its inner circumference by the outer surface of shuttle post 364. Drive spring 336 may be captivated at its bottom and outer circumference by the inside surface of shuttle post 364, at its top by the ceiling 372 inside actuator button 324, and/or at its inner circumference by stem 374 depending from ceiling 372. When drive spring 336 is compressed between actuator button 324 and shuttle 338 it urges shuttle 338 towards base 344. When retraction spring 342 is compressed between shuttle 338 and base 344, it urges shuttle 338 towards actuator button 324.

[0045] Actuator button 324 may be slidably received within housing 334 from below and reside in opening 376 at the top of housing 334 with limited longitudinal movement. Arms 378 on each side of actuator button 324 may travel in channels 380 along the inside walls of housing 334, as best seen in FIG. 8. Longitudinal movement of actuator button 324 may be limited in one direction by the base of arms 378 contacting the edge of opening 376 at the top of housing 334, and in the other direction by the distal ends 384 of arms 378 contacting stops 386 in channels 380. In this embodiment, slots 388 are provided in the top of housing 334 for ease of housing manufacture and so tools may be inserted to inwardly compress areas 378 beyond stops 386 to allow actuator button 324 to be removed from housing 334 if needed.

[0046] When sensor 314, introducer 340, shuttle 338, retraction spring 342, drive spring 336 and actuator button 324 are assembled between base 344 and housing 334 as shown in FIG. 4 and described above, housing 334 may be snapped into place on base 344. Base 344 may be held onto housing 334 by upper base barbs 390 that engage upper openings 392 in housing 334, and lower base barbs 394 (best seen in FIG. 5) that engage lower openings 396 in housing 334. In this embodiment, slots 398 and 400 are provided for ease of manufacture of housing 334, and base 344 is removable from housing 334 with tools if needed.

[0047] Referring to FIG. 7, actuator button 324 may be provided with safety lock tabs 322 hingedly formed on opposite ends. Tabs 322 may be urged from a relaxed outward position to a flexed inward position. When in the normal outward position, shoulders 402 on the outer surfaces of tabs 322 engage the rim 404 of opening 376 to prevent the actuator button 324 from being depressed, thereby avoiding accidental firing of inserter 310. Tabs 322

maybe squeezed inward just enough to clear the rim 404 of opening 376 while pressing the actuator button 324 down to fire the inserter. Alternatively, tabs 322 may be squeezed further inward so that barbs 406 on the inside edges engage catches 408 located on a center portion of actuator button 324, thereby defeating the safety lock to allow later firing by simply pressing down on the actuator button 324. In this embodiment, upwardly extending grips 410 are provided on tabs 322 for better visual indication of safety lock status and actuation control.

[0048] Referring to FIG. 8, shuttle 338 may be provided with laterally extending barbed fingers 412 which travel in channels 380 along the inside walls of housing 334. When shuttle 338 is inserted up into housing 334 far enough in this embodiment, barbed fingers 412 momentarily deflect inward and then snap outward again to catch on stops 386. In this "cocked" position as shown, drive spring 336 may be compressed and urging shuttle 338 towards base 344, but barbed fingers 412 catching on stops 386 prevent such travel.

[0049] Referring to FIGS. 9-11, the sequence of loading, cocking, arming, firing, and automatic retraction of exemplary inserter 310 will be described. According to aspects of the invention, during production inserters 310 may be fabricated and fully assembled by one vendor, except for sensor 314, which may be supplied and installed by a second vendor in a sterile environment. Accordingly, inserter 310 may be manufactured and shipped to the sensor vendor in a neutral state, as shown in FIG. 9. A hole 414 provided through the center of actuator button 324 allows the sensor vendor to insert a pin (manually or by automated machinery, not shown) through hole 414 to drive shuttle 338 towards base 344 in a controlled fashion and hold it there against the force of retraction spring 342. This will allow introducer sharp 340 to be extended through base 344 (as shown in FIG. 11) so that sensor 314 may be loaded into introducer 340. When the pin is removed, shuttle 338, introducer 340 and sensor 314 may be allowed to retract to the neutral position. The sensor vendor may then cock the loaded inserter 310 before shipment by pushing another pin (not shown) from the opposite direction through a central hole 416 in base 344 (with mount 312 removed) until the pin contacts dimple 418 formed in the bottom of shuttle 338. By pushing shuttle 338 towards actuator button 324 until barbed fingers 412 clear stops 386, the inserter 310 may be cocked (as shown in FIG. 10.)

[0050] Referring to FIG. 10, inserter 310 may be received by the patient in the cocked position as shown. To use inserter 310, the patient may apply mount 312 to the mounting site and may disable the safety mechanism as previously described, and may then push actuator button 324 against the force of drive spring 336. As actuator button 324 travels toward base 344, drive cam surfaces 420 on arms 378 contact ramped surfaces 422 of barbed fingers 412 and urge them inward. When fingers 412 are driven inward enough to clear stops 386, shuttle 338 may be driven by drive spring 336 with a predetermined speed and force to an insertion position, as shown in FIG. 11.

[0051] Referring to FIG. 11, exemplary inserter 310 is shown in the insertion position with the tail 424 of introducer sharp 340 extending through base 344 and mount 312 into the skin of the patient. FIG. 11 shows shuttle 338 in a fully extended position with its lower surface 426 bottomed out on base 344. However, in this embodiment, the lower

orthogonal surface 356 of sensor 314 will contact an exposed sensor contact portion 428 (best seen in FIGS. 2 and 4) on top of adhesive tape 320 supported from below by the patient's skin, and therefore will typically stop traveling before reaching the fully bottomed out position shown. Tail 424 of introducer sharp 340 may provide rigidity and a skin piercing edge 430 for allowing the flexible tail 431 of sensor 314 to be implanted in the patient's skin. After providing this function, introducer sharp 340 may be immediately removed from the patient and retracted into a safe position inside housing 334 as retraction spring 342 (which has been compressed by the travel of the shuttle) pushes shuttle 338 back towards actuator cap. Sensor 314 may be pulled from introducer 340 and held in place by the sensor contact portion 428 on top of adhesive tape 320 adhering to orthogonal surface 356 of sensor 314. The geometries of sensor dimple 350 and mating introducer dimple 352 may be chosen to create a separation force between them that is less than the adhesion force of tape 320 on orthogonal surface 356, but great enough to retain sensor 314 in introducer 340 during typical shipping and product handling shock loads. Driving surface 358 beneath shuttle 338 may press down on top of orthogonal surface 356 to ensure good contact with adhesive tape 320 before shuttle 338 retracts within introducer 340. Barb(s) on sensor tail 431 may be employed to further anchor the sensor in its operating position.

[0052] Referring again to FIG. 9, in this embodiment retraction spring 342 will return shuttle 338 to the neutral position as shown after firing, but without sensor 314 which remains inserted in patient's skin (not still in introducer 340 as shown here.) Drive spring 336 may be designed to be stiffer than retraction spring 342 so that shuttle 338 oscillations are quickly dampened out, and so introducer sharp 340 does not return to sensor 314 or the patient to cause injury. With sensor 314 now inserted in the patient's skin, inserter 310 may be removed from mount 312 by inwardly flexing release tabs 326 on opposite sides of inserter 310 to remove latch hooks 432 from mount channels 434 and then lifting inserter 310 away from mount 312. Introducer sharp 340 remains protected inside housing 334 during disposal of inserter 310. Transmitter 330 may now be slid into place on mount 312 as previously described.

[0053] In one embodiment, sensor 314 may be made from a 0.005 inch thick Mylar substrate, such as Dupont Melinex ST-505, print treated both sides, heat stabilized and biaxially oriented. In this embodiment, main surface 346 is 0.315 tall by 0.512 wide, and orthogonal surface 356 is 0.374 wide by 0.202 deep. Sensor tail 431 is 0.230 long by 0.023 wide. Semispherical sensor dimple 350 is 0.050 inches wide and 0.026 inches deep. Introducer 340 is made from SUS 301 medical grade stainless steel, 0.004 inches thick, having a surface roughness less than or equal to 0.5 micrometers. The height of the main portion of introducer 340 is 0.614 inches, and the inside width is 0.513 inches. The overall thickness of rolled rails 348 is 0.026 inches. The length and width of introducer tail 424 are 0.354 and 0.036 inches, respectively. The preferred angle of the sharp 340 is 21 degrees. Semispherical introducer dimple 352 has a radius of 0.024 inches. Also, in this embodiment, shuttle 338 has an average speed of at least 1 meter/second, and has a momentum at its end of travel of about 2.65 lb-m/sec.

[0054] In the above exemplary embodiment, housing 334, button 324, shuttle 338, base 344 and mount 312 are all injection molded from G.E. Lexan PC. Inside and outside

working surfaces of arms 378 on button 324 are lubricated with Dow Corning 360 Medical Fluid. Drive spring 336 has a free length of 1.25 inches, a working length of 1.00 inch, and a rate between 20 and 30 pounds per inch. Retraction spring 342 has a free length of 1.5 inches, a working length of 0.35 inches, and a rate between 0.15 and 0.35 pounds per inch. Adhesive tape 320 is medical grade acrylic adhesive on polyester film (such as Acutek 0396013) with a semi-bleached kraft liner having silicon release.

[0055] The following enhancements may be added to the inserter kit 300 described above in an effort to increase the reliability of sensor insertion. First, a sensor flap 466, as shown in FIG. 13, may be formed along the top edge of sensor 314. When sensor 314 reaches the extended, delivered position as shown in FIG. 11, flap 466 catches on bottom edge 468 of base 344, shown in FIG. 7, to ensure that sensor 314 separates from introducer 340 as shuttle 338 returns upward to the retracted position. Adhesive may also be located on the bottom of orthogonal sensor surface 356 to ensure that sensor 314 adheres to the sensor contact portion 428 on the top of adhesive mount tape 320, as shown in FIG. 4.

[0056] Referring to FIGS. 16A and 16B, an alternative embodiment is shown. Actuator button 324' may be made easier for elderly patients to push by anchoring the upper end of drive spring 336 on a housing bridge 470 instead of button 324. This option may also make the insertion force of inserter 310 more consistent, and may allow stronger spring forces to be used if desired. Bridge 470 may span across opening 376' and divide it into two openings 472 in the top of housing 334'. The top portion of button 324' may be bifurcated into two protrusions 474 that each extend through an opening 472. A clearance hole (not shown) may be provided through the center of button 324' to allow drive spring 336 to pass through and secure around a post (not shown) depending from the bottom center of bridge 470.

[0057] Safety lock key 476 may be provided to prevent actuator button 324' from being pressed until key 476 is removed. Aperture 478 may be provided in the top center of bridge 470 for receiving boss 480 located at the bottom of key 476, thereby allowing key 476 to rotate. When key handle 482 is rotated perpendicular to button protrusions 474 in the embodiment shown in FIGS. 16A and 16B, two opposing perpendicular fins 484 on key 476 swing into inwardly facing slots (not shown) on the inside of protrusions 474 and prevent button 324' from being actuated. When key handle 482 and fins 484 are rotated parallel to button protrusions 474 such that fins 484 disengage therefrom, key 476 may be removed and button 324' may then be actuated. Other than these modifications, this alternative embodiment inserter kit 300' functions the same as the embodiments previously described.

[0058] In another embodiment, less aggressive finger engagement with stops 386 may be employed to provide an easier and more consistent release of shuttle 338 by actuator button 324 or 324'. Alternatively, the above designs may be modified to have a single, more centrally located shuttle release finger (not shown) instead of the two outboard fingers 412 shown.

[0059] Referring to FIGS. 17-20, various alternative embodiments are shown comprising features which allow the sensor insertion velocity to be changed. Referring first to FIG. 17, an inserter 500 embodiment having a micrometer style head or knob 502 is shown, similar in arrangement to

inserter embodiments described above. Knob 502 may be attached to a threaded rod 504. Threaded rod 504 may be received through a threaded hole or insert in fixed housing cross member 506. A distal end of threaded rod 504 may be rotatably or fixedly attached to compression member 508. Compression member 508 may be movable with respect to carrier or shuttle 510 for compressing drive spring 512 therebetween.

[0060] Shuttle 510 may be provided with barbed fingers 514 for engaging stops 516 within housing 518 to releasably retain shuttle 510 in a cocked position, similar to the arrangements of embodiments described above. Inserter 500 may be provided with an actuator button (such as 324 shown in FIG. 1) for releasing barbed fingers 514 from stops 516 as also previously described, allowing drive spring 512 to drive shuttle 510 downward with introducer sharp and/or sensor 520 to be inserted into the patient's skin. A return spring 522 may also be provided to retract shuttle 510 into housing 518 after sensor insertion.

[0061] The driving force, travel distance, velocity, acceleration and/or other characteristics of sensor insertion may be adjusted according to aspects of the present invention. In this embodiment, the user may turn knob 502 causing threaded rod 504 to rotate within the threaded hole or insert in housing cross member 506. Turning knob 502 in one direction causes knob 502, rod 504 and compression member 508 to move downward, thereby further compressing drive spring 512 against shuttle 510. Turning knob 502 in the opposite direction reduces the compression of drive spring 512. By turning knob 502 prior to firing inserter 500, a user may increase or decrease the insertion speed and/or other characteristics of sensor insertion.

[0062] Knob 502, rod 504 and/or housing 518 may be provided with numbers, lines, pointers or other indicia to aid a user in setting knob 502 in a desired location. In this particular embodiment, a user may adjust knob 502 prior to cocking inserter 500 to reduce the amount of force needed to turn knob 502, since drive spring 512 may not be compressed or as compressed in an uncocked state. Alternatively, knob 502 may be turned after inserter 500 has been cocked. This scenario may provide the user with feedback during adjustment, as inserter 500 may be designed to allow the user to feel more resistance in turning knob 502 as drive spring 512 is further compressed. It should be noted that in this embodiment, a user is allowed to variably adjust an insertion characteristic such as insertion speed across a range of speeds by turning knob 502 through a range of positions. In one embodiment, inserter 500 is provided to a user with knob 502 set in a middle of a range so that the user may either increase or decrease the insertion speed, or leave it at its default setting.

[0063] In an alternative embodiment (not shown), which is a variation of the embodiment shown in FIG. 17, knob 502 may be arranged so that it remains in a fixed location while being free to turn. In this embodiment, a threaded hole or insert may be provided within either knob 502 or compression plate 508, and threaded rod 504 may be fixed attached to the other. This arrangement may operate in a similar fashion to the embodiment shown in FIG. 17 and allow fixed housing cross member 506 to be eliminated.

[0064] In another alternative embodiment (not shown), which is another variation of the embodiment shown in FIG. 17, knob 502, threaded rod 504 and compression member 508 may be replaced with a housing cap that rotatably engages

with the main housing, such as with a threaded coupling. The drive spring may be captured between the cap and shuttle 510. As the cap is threaded into further engagement with the main housing, the drive spring is further compressed. Conversely, the cap may be backed away from the main housing to reduce the compression of the drive spring. As before, the compression setting of the drive spring may affect characteristics of sensor insertion, such as sensor delivery speed.

[0065] Referring now to FIGS. 18A and 18B, another alternative inserter 600 embodiment is shown. Inserter 600 may include a thumbwheel 602. Thumbwheel 602 may protrude from housing 604 as shown to allow a user to easily turn it for adjusting a parameter(s) of sensor insertion. Thumbwheel 602 may drive threaded rod 606 directly, or indirectly by rotatably engaging pinion 608. Pinion 608 or compression member 610 may include a threaded hole or insert for receiving threaded rod 606. With this arrangement, rotation of thumbwheel 602 causes threaded rod 606 to lower or raise compression plate 610, thereby further compressing or decompressing drive spring 612, respectively. Thumbwheel 602 and/or housing 604 may be provided with numbers, lines, pointers or other indicia to aid a user in setting thumbwheel 602 in a desired position. A window may be provided atop housing 604 to allow one or more indicia on thumbwheel 602 to be viewed. In all other respects, inserter 600 shown in FIGS. 18A and 18B may operate in a similar manner to that of inserter 500 shown in FIG. 17.

[0066] Referring now to FIGS. 19A and 19B, another alternative inserter 700 embodiment is shown. Inserter 700 includes a shuttle 702 that may be rotated to affect compression of drive spring 704. As seen in FIG. 19A, barbed fingers 706 may engage with a first pair of stops 708 to hold shuttle 702 in a cocked position at a first height. As seen in FIG. 19B, inserter 700 may be provided with a second pair of stops 710. The second pair of stops 710 may be located within housing 712 at a second height which is lower than the first height. Inserter may be provided with provisions to allow shuttle 702 to be rotated 90 degrees so that barbed fingers 706 may engage with either the first pair of stops 708 or the second pair of stops 710 when shuttle 702 is cocked. In this embodiment, when barbed fingers 706 are engaged with the higher first pair of stops 708 as shown in FIGS. 19A and 19B, drive spring 704 is compressed more than when barbed fingers 706 are engaged with the lower second pair of stops 710, which may result in a higher sensor velocity when inserter 700 is actuated. It should be noted that this embodiment may provide the user with individual, discrete adjustment settings as opposed to a continuously variable range of settings as may be provided with the previously described embodiments.

[0067] In alternative embodiments (not shown), more than two pairs of stops may be provided to provide additional positions of drive spring compression. Such arrangements may be used with square, round or other shapes of housings. In other embodiments, one pair of stops 708 may be provided on housing 712, and multiple pairs of barbed fingers 706 may be located at different heights on shuttle 702 for alternating engagement with the pair of stops 708. Alternatively or in conjunction with this embodiment, stop(s) 708 may be located on shuttle 702 while barbed finger(s) 706 may be located on housing 712. Other variations of these

embodiments may occur to those skilled in the art without departing from the scope of the present invention.

[0068] Referring now to FIGS. 20A and 20B, another alternative inserter **800** embodiment is shown. Inserter **800** includes at least one magnet **802** which may affect the compression of drive spring **804**. Drive spring **804** may be located between shuttle **806** and a top portion **808** of housing **810**. Shuttle **806** may include a ferrous material and/or one or more magnets (not shown) for attracting shuttle **806** to magnet **802**. Magnet **802** may be located above shuttle **806** on pivot arm **812**, which may pivot about hinge **814**. In this embodiment, a magnetic attraction between magnet **802** and shuttle **806** compresses drive spring **804** and holds shuttle **806** in a cocked position. Pressing on firing tab **816** causes arm **812** to pivot about hinge **814** in the direction shown by Arrow A and raises magnet **802** away from shuttle **806**. The increased separation between magnet **802** and shuttle **806** decreases the magnetic attraction between the two until the force of compressed drive spring **804** exceeds the force of magnetic attraction. At this point, drive spring **804** is allowed to extend, firing sensor **818** into the user's skin.

[0069] The degree of magnetic attraction between shuttle **806** and magnet(s) **802** may be varied by the size, number, location and/or polarity of magnet(s) **802**. For example, a user may place additional magnets **802** on top of pivot arm **812** to further compress drive spring **804**. This in turn may provide a higher sensor insertion velocity. In alternative embodiments, magnet(s) may be used in conjunction with previously described embodiments to affect spring compression. In such embodiments, no magnet may be used for a low speed setting, and one or more magnets may be used for higher speed setting(s).

[0070] In other embodiments (not shown), separate cartridges may alternately be installed by a user, each cartridge having a different spring rate for providing different insertion characteristics. Alternatively, a wind-up type constant force spring may be utilized to vary the spring force. Such an arrangement may also use a ratchet and lock type mechanism to affect the winding. In yet other embodiments, internal dampeners or other features may be used to allow adjustment of the firing characteristics of the inserter. For example, air bladders, movable walls or contact areas can be employed to increase, decrease or remove friction, thereby allowing sensor shuttle speed to be varied.

[0071] In the embodiments described above, a force or forces to drive a sensor or other object into a body may come from a compression spring, an extension spring, a torsion spring, a pneumatic or hydraulic cylinder or bladder, a magnet, an electromagnet or other prime mover or device for storing potential energy known to those skilled in the art.

[0072] In the embodiments described above, the entire insertion device or portions thereof can be either disposable or reusable.

[0073] As for additional details pertinent to the present invention, materials and manufacturing techniques may be employed as within the level of those with skill in the relevant art. The same may hold true with respect to method-based aspects of the invention in terms of additional acts commonly or logically employed. Also, it is contemplated that any optional feature of the inventive variations described may be set forth and claimed independently, or in combination with any one or more of the features described herein. Likewise, reference to a singular item, includes the possibility that there are plural of the same items present.

More specifically, as used herein and in the appended claims, the singular forms "a," "and," "said," and "the" include plural referents unless the context clearly dictates otherwise. It is further noted that the claims may be drafted to exclude any optional element. As such, this statement is intended to serve as antecedent basis for use of such exclusive terminology as "solely," "only" and the like in connection with the recitation of claim elements, or use of a "negative" limitation. Unless defined otherwise herein, all technical and scientific terms used herein have the same meaning as commonly understood by one of ordinary skill in the art to which this invention belongs. The breadth of the present invention is not to be limited by the subject specification, but rather only by the plain meaning of the claim terms employed.

What is claimed as the invention is:

1. A sensor insertion device comprising:

a shuttle movable between a first position and a second position, the shuttle configured to retain a transcutaneous sensor while in the first position and release the sensor while in the second position;

a means for providing a force to drive the shuttle from the first position to the second position; and

a means for varying the driving force while the shuttle is stationary.

2. The insertion device of claim 1, wherein the means for varying the driving force may be operated by a user of the insertion device.

3. The insertion device of claim 1, wherein the driving force may be varied over a continuous range of settings.

4. The insertion device of claim 1, wherein the driving force may be alternately set to one of a plurality of discrete settings.

5. The insertion device of claim 1, wherein the means for varying the driving force includes a knob configured to be twisted by a user of the insertion device.

6. The insertion device of claim 1, wherein the means for varying the driving force includes a thumbwheel configured to be turned by a user of the insertion device.

7. The insertion device of claim 1, wherein the means for varying the driving force includes a component configured to be set to one of a plurality of discrete, alternate orientations by a user of the insertion device.

8. The insertion device of claim 7, wherein the component includes the shuttle.

9. The insertion device of claim 1, wherein the means for varying the driving force includes a magnet.

10. The insertion device of claim 1, wherein the means for varying the driving force includes a threaded rod.

11. The insertion device of claim 1, wherein the means for providing a force includes a compression spring.

12. An improved sensor insertion device of the type which drives a sensor into a living body, the improvement comprising a mechanism configured to allow a sensor insertion velocity of the insertion device to be set to one of a plurality of settings.

13. The insertion device of claim 12, wherein the mechanism is configured to allow a user of the insertion device to set the sensor insertion velocity.

14. The insertion device of claim 12, wherein the plurality of settings includes a continuous range of settings.

15. The insertion device of claim 12, wherein the plurality of settings includes discrete settings.

16. The insertion device of claim **12**, wherein the mechanism allows the amount of compression of a drive spring to be changed.

17. A method of inserting a sensor, the method including the steps of:

- cocking an automatic sensor insertion device;
- selecting an insertion speed setting from among a plurality of insertion speed settings on the insertion device;
- placing the insertion device against the skin of a living body; and

firing a sensor into the skin using the selected insertion speed.

18. The method of claim **17**, wherein the selecting step is performed before the cocking step.

19. The method of claim **17**, wherein the plurality of settings includes a continuous range of settings.

20. The method of claim **17**, wherein the plurality of settings includes a finite number of discrete settings.

* * * * *