



US 20130086795A1

(19) **United States**

(12) **Patent Application Publication**
Davidson et al.

(10) **Pub. No.: US 2013/0086795 A1**

(43) **Pub. Date: Apr. 11, 2013**

(54) **CUSHION FOR PATIENT INTERFACE**

(71) Applicant: **ResMed Limited**, Bella Vista (AU)

(72) Inventors: **Aaron Samuel Davidson**, Newport (AU); **Robin Garth Hitchcock**, Carlingford (AU); **Matthew Eves**, Carlingford (AU); **David John Worboys**, Belrose (AU); **Susan Robyn Lynch**, Epping (AU)

(73) Assignee: **ResMed Limited**, Bella Vista (AU)

(21) Appl. No.: **13/688,875**

(22) Filed: **Nov. 29, 2012**

Related U.S. Application Data

(63) Continuation of application No. 13/537,876, filed on Jun. 29, 2012, which is a continuation of application No. 11/793,981, filed on Jun. 25, 2007, now Pat. No. 8,220,459, filed as application No. PCT/AU2006/000032 on Jan. 12, 2006.

(60) Provisional application No. 60/724,303, filed on Oct. 7, 2005, provisional application No. 60/643,130, filed on Jan. 12, 2005.

Publication Classification

(51) **Int. Cl.**
A62B 18/08 (2006.01)
(52) **U.S. Cl.**
CPC *A62B 18/08* (2013.01)
USPC **29/592**

(57) **ABSTRACT**

A cushion for a patient interface that delivers breathable gas to a patient includes a base wall structured to be connected to a frame, an underlying support cushion extending away from the base wall towards the patient's face in use, and a membrane provided to substantially cover at least a portion of the underlying cushion. The membrane is adapted to form a continuous seal on the patient's face. The underlying cushion has a spring-like connection with the base wall. The underlying cushion and/or base wall define a spring constant that varies along a length of the seal.

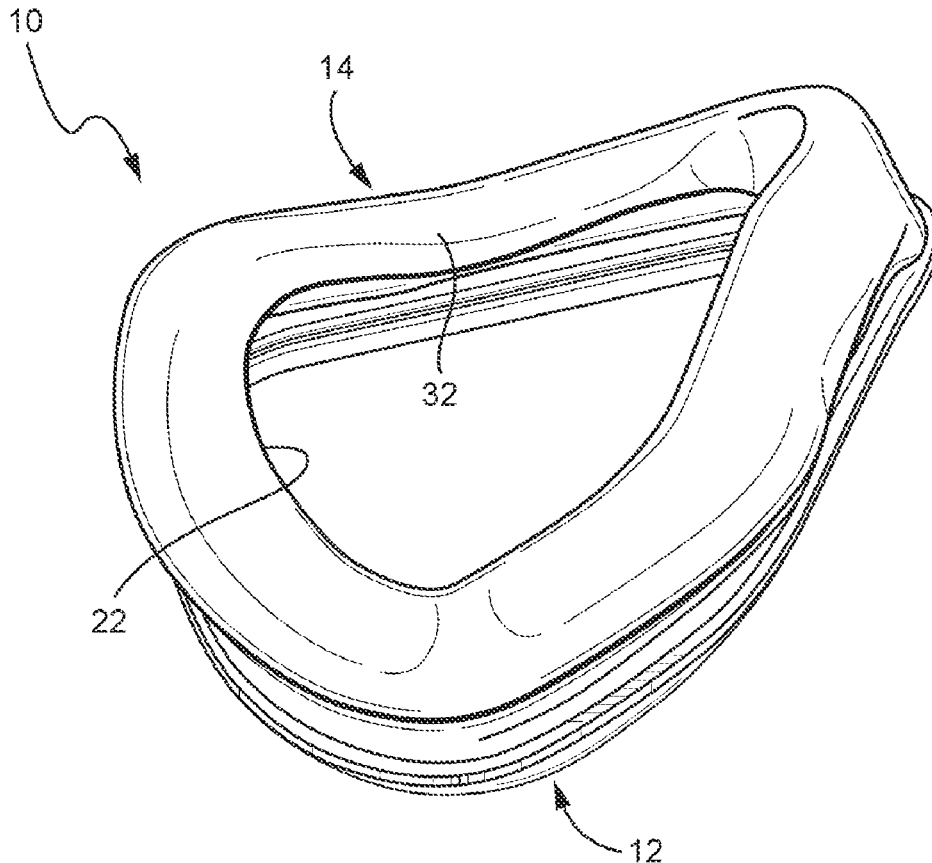

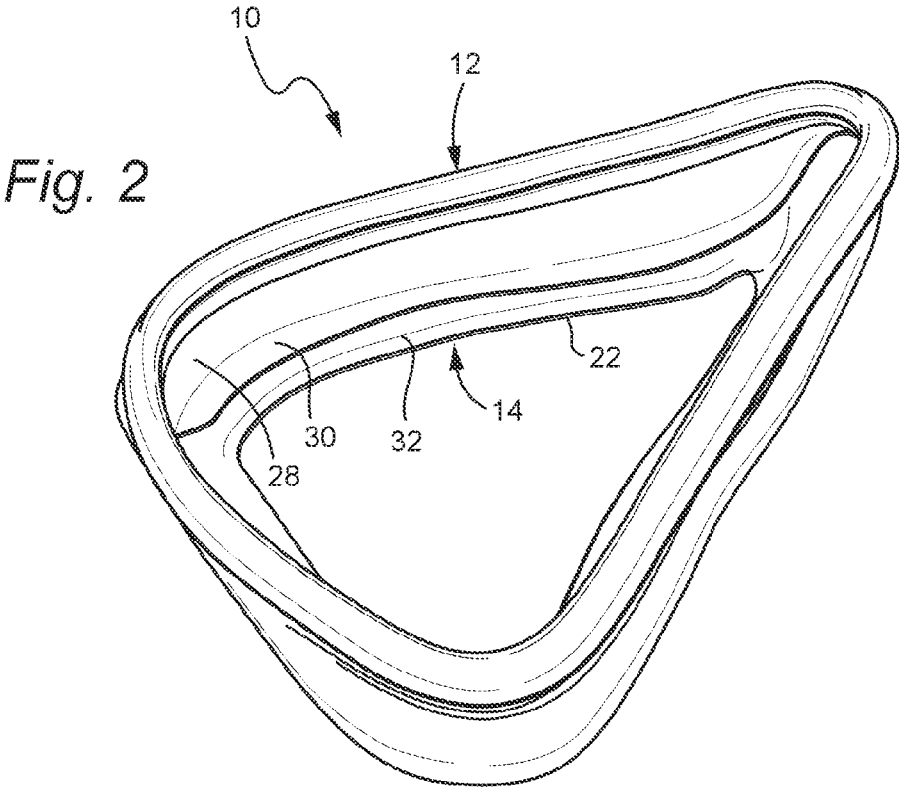
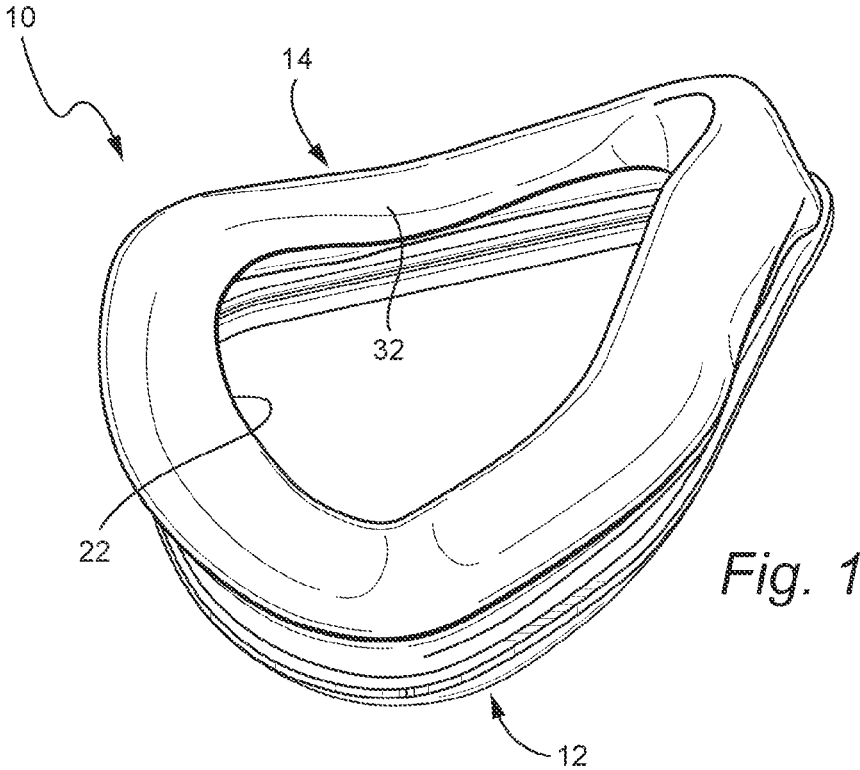

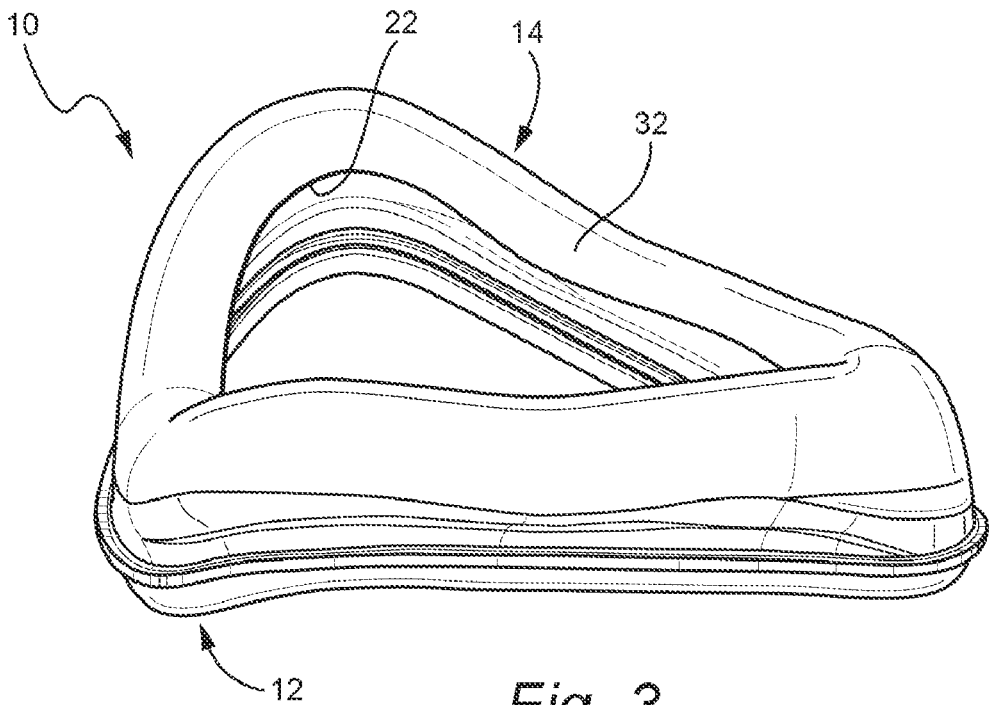

Fig. 3

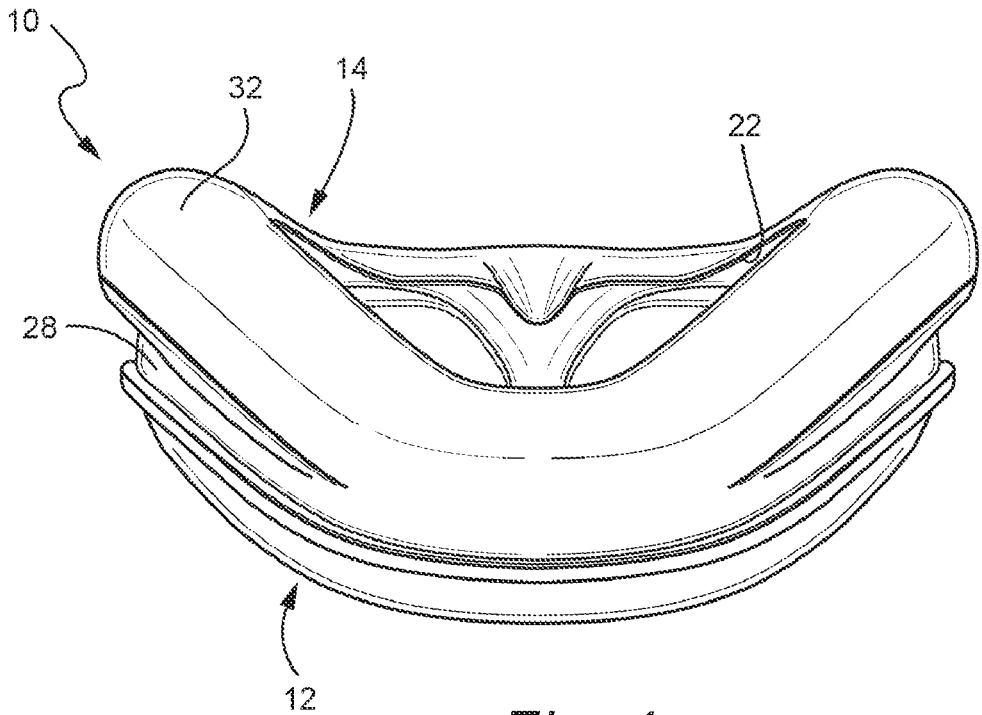

Fig. 4

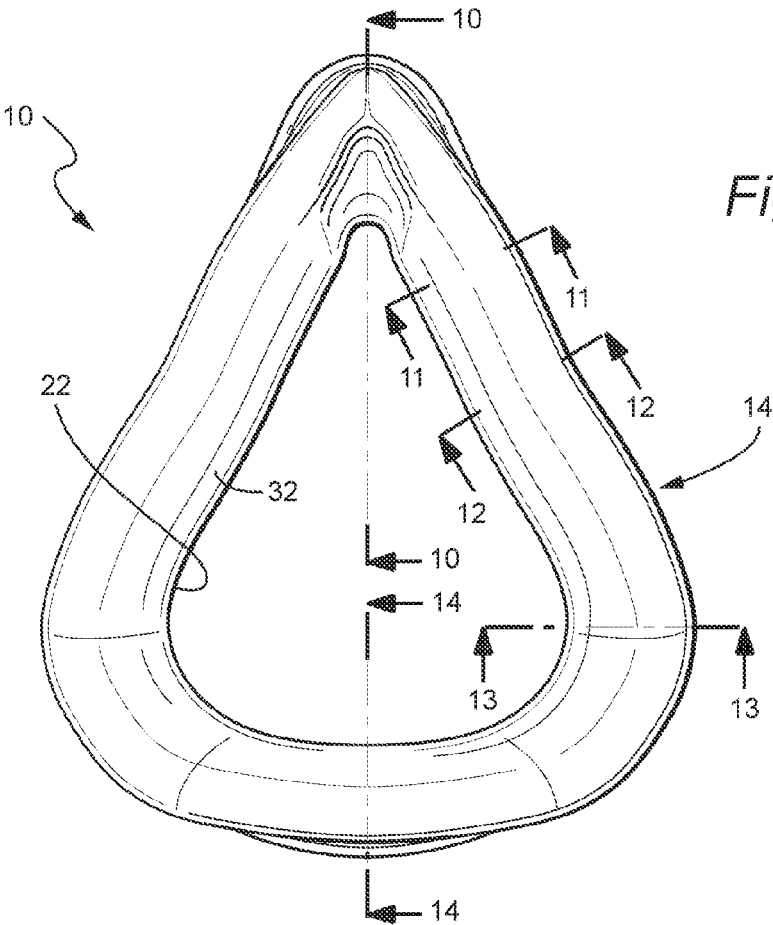

Fig. 5

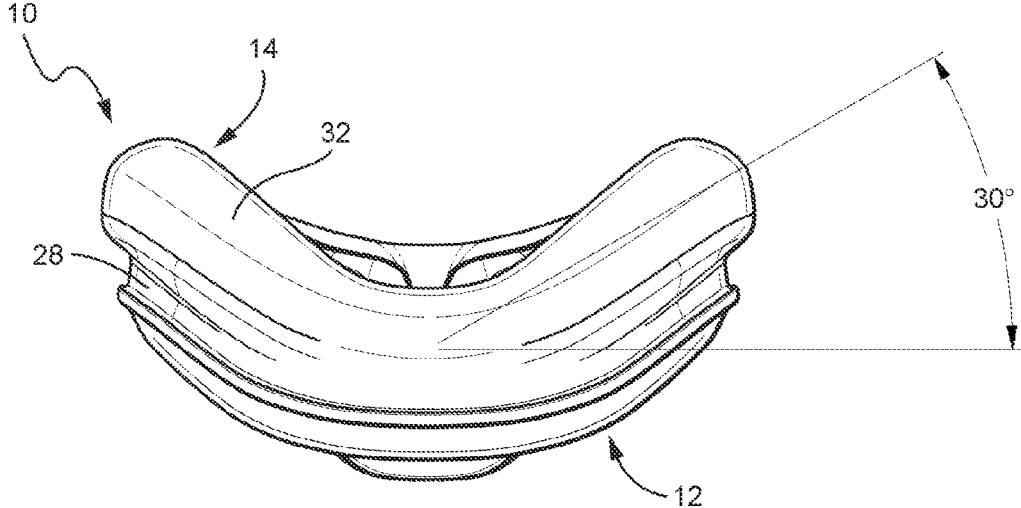
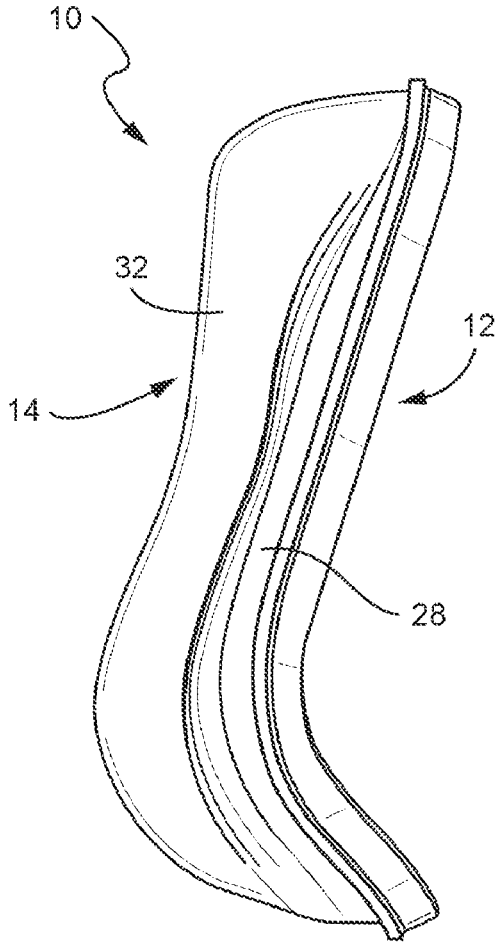
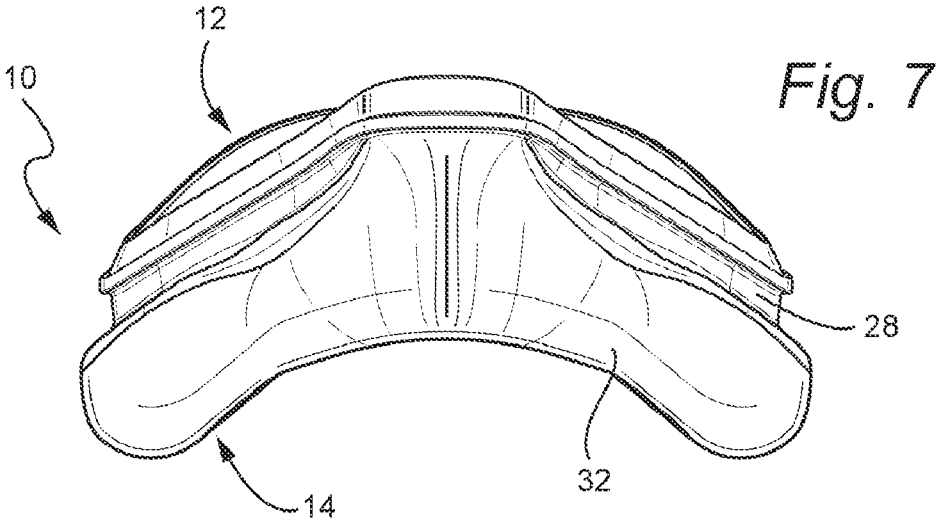

Fig. 6



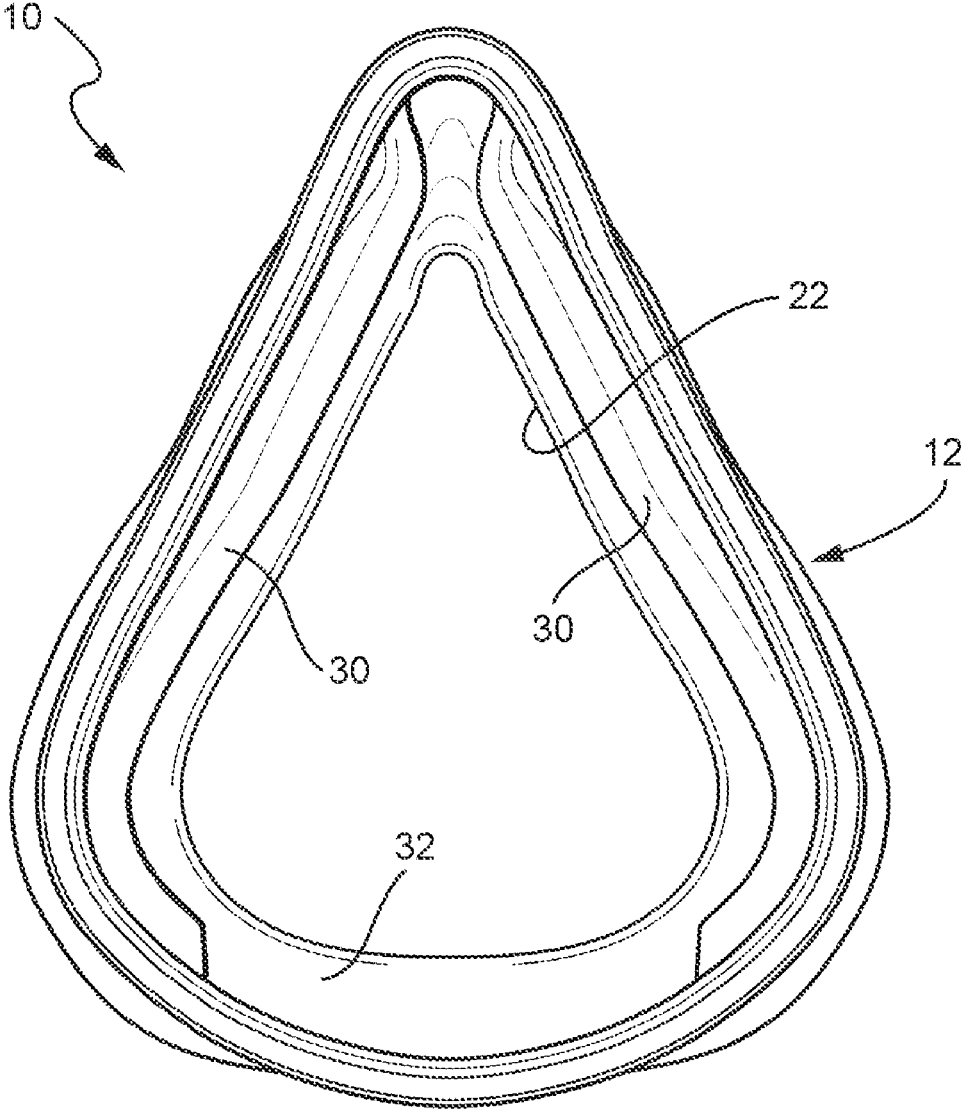

Fig. 9

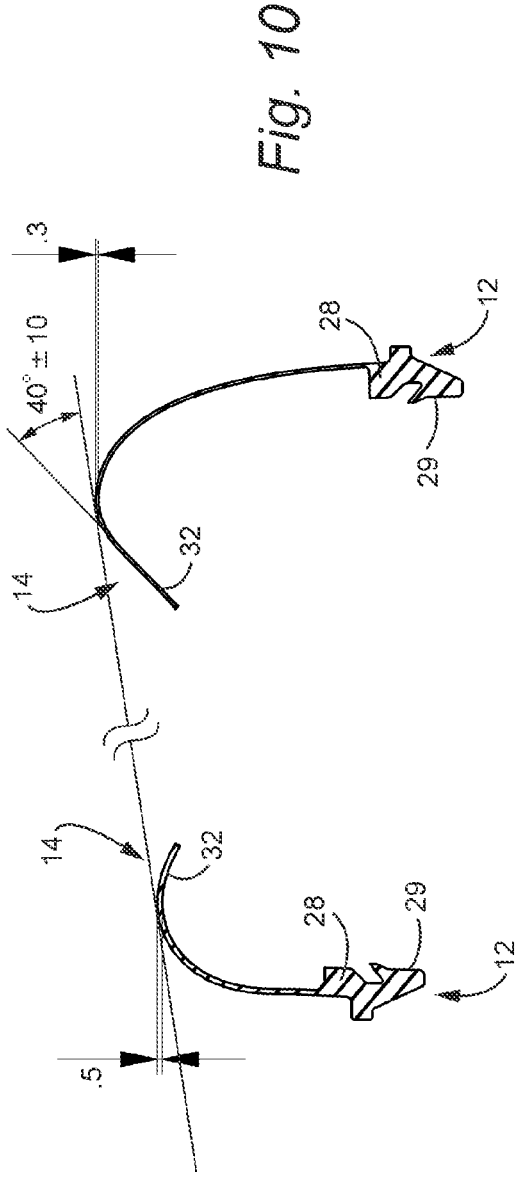

Fig. 10

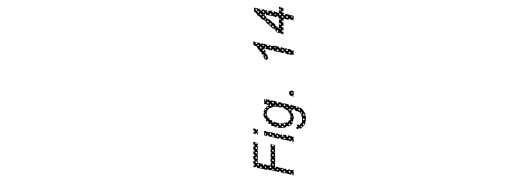

Fig. 14

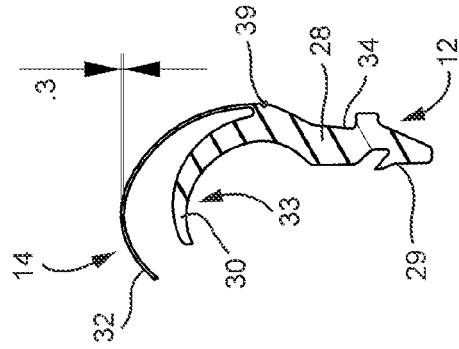

Fig. 11

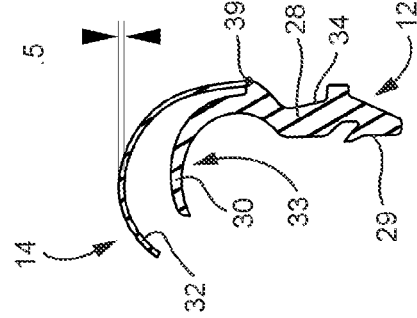

Fig. 12

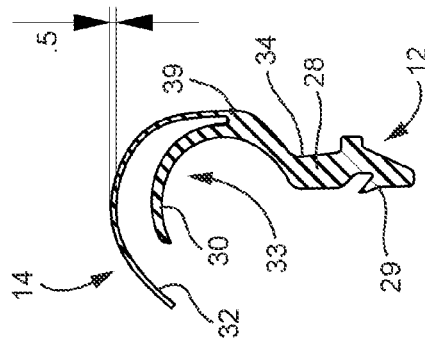

Fig. 13

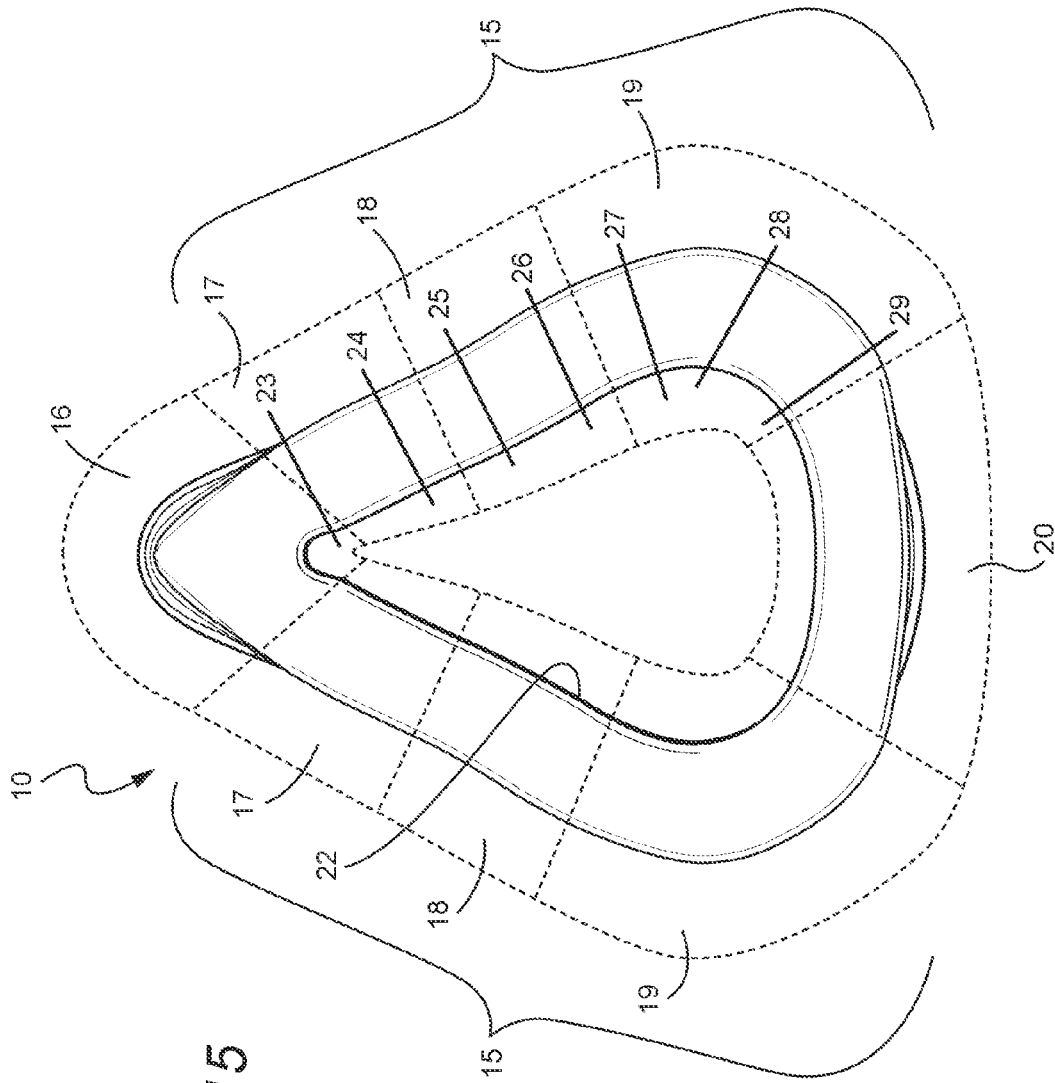

Fig. 15

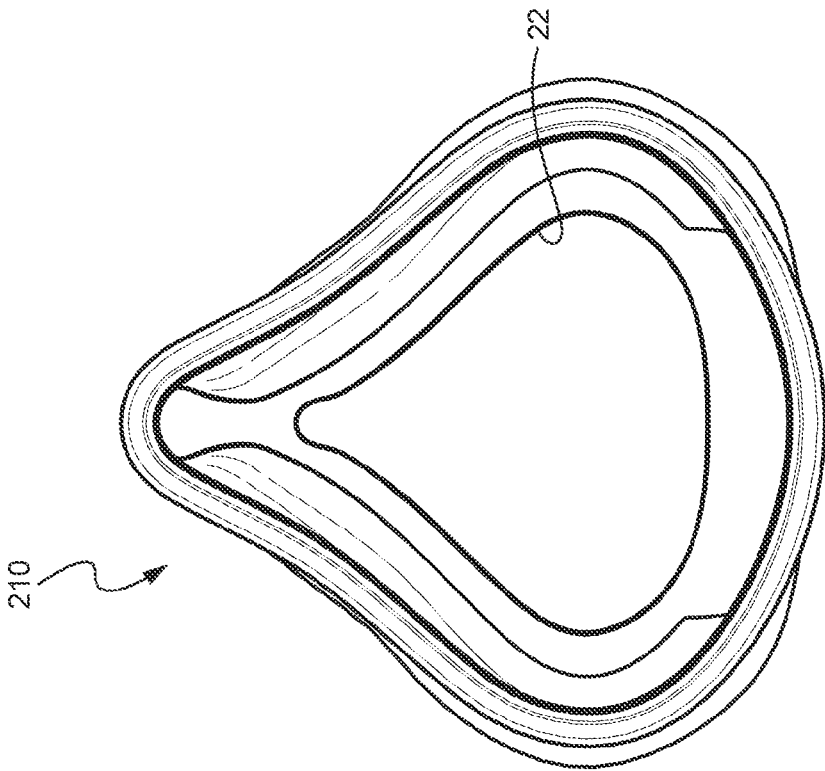

Fig. 17

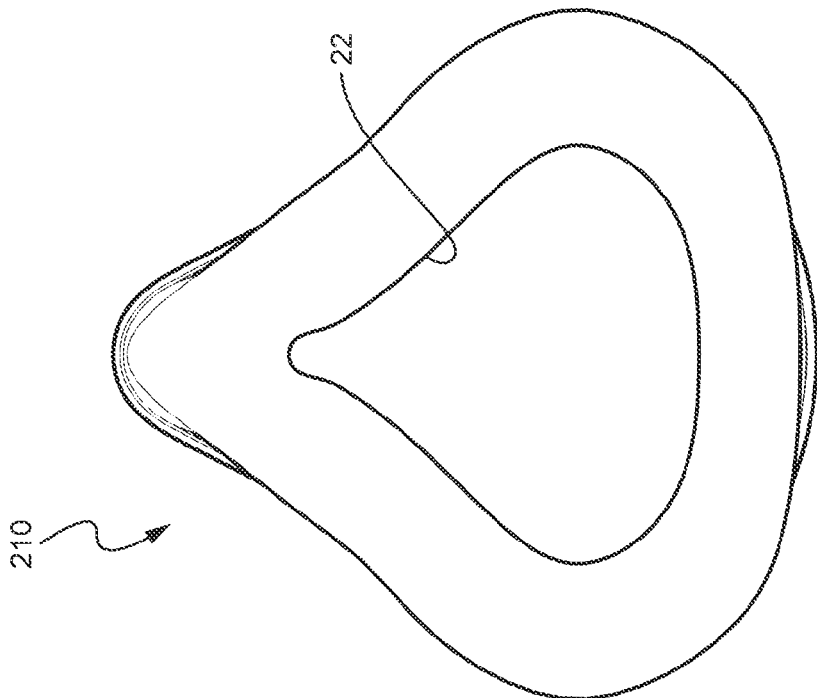

Fig. 16

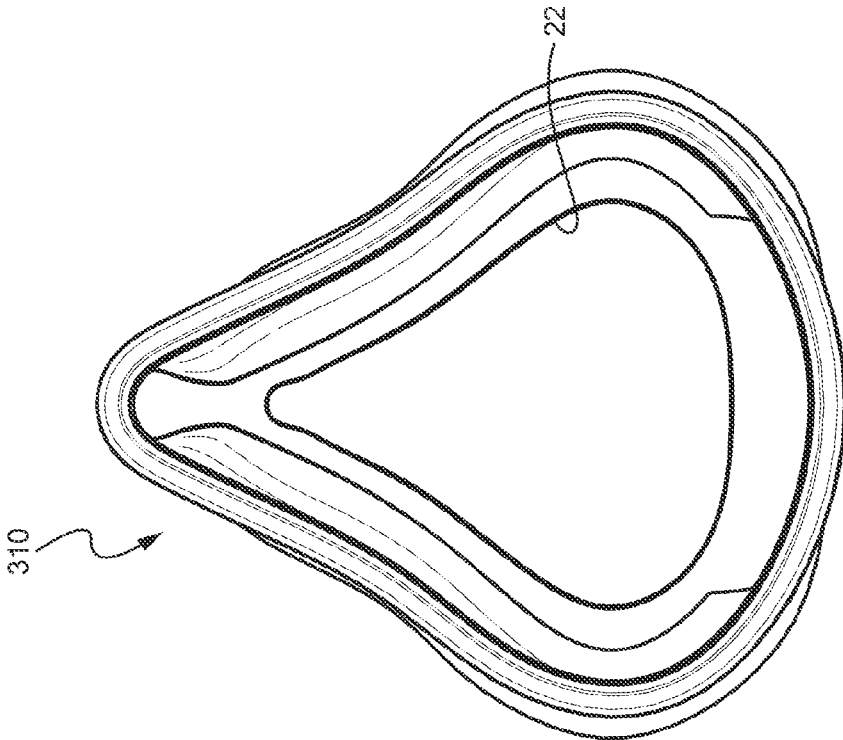

Fig. 19

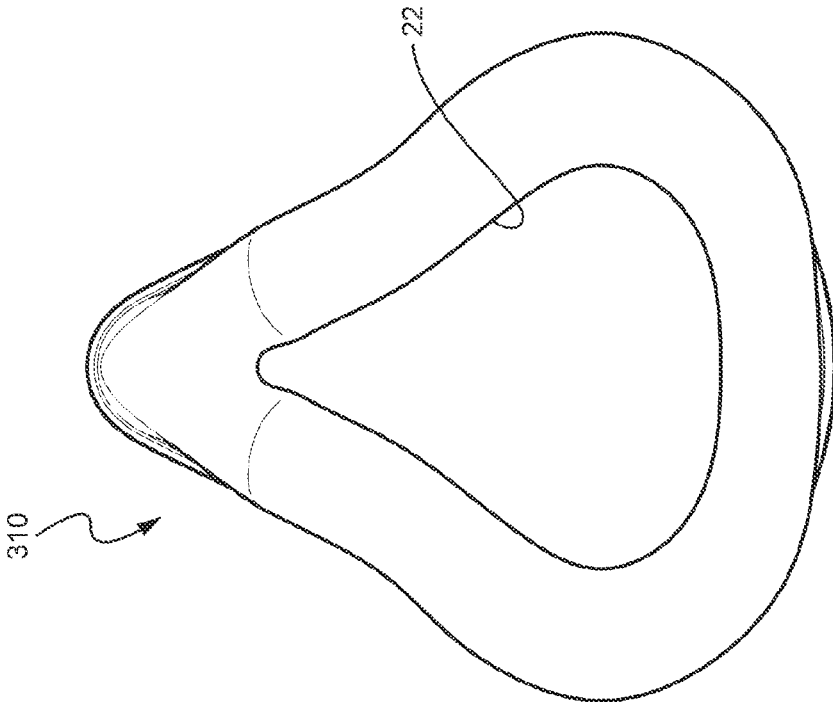
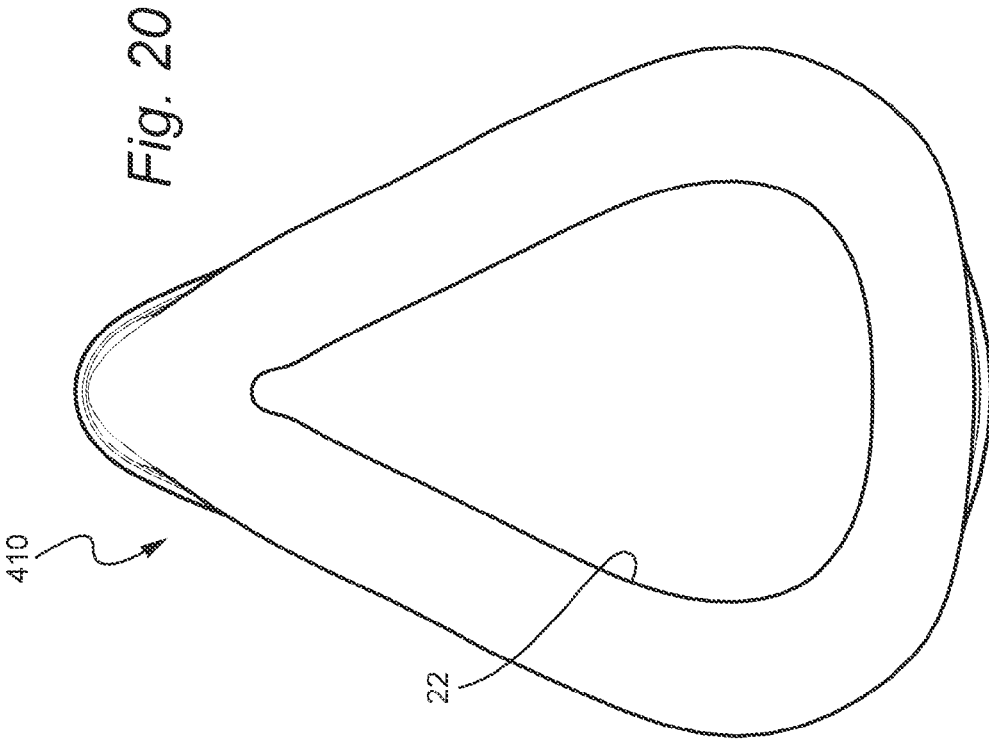
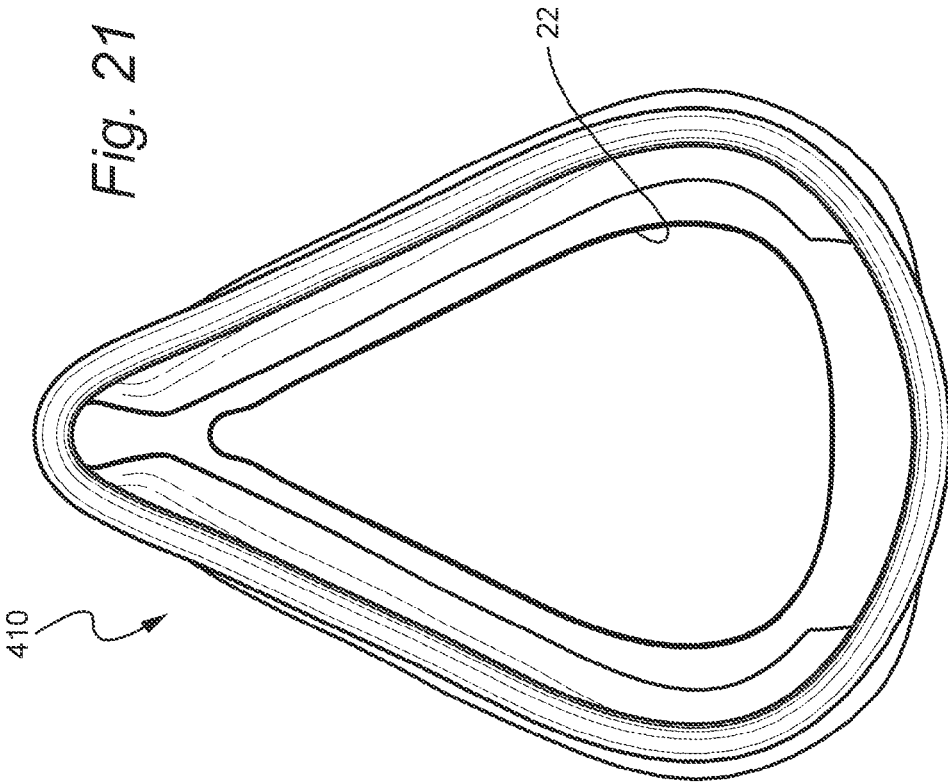

Fig. 18



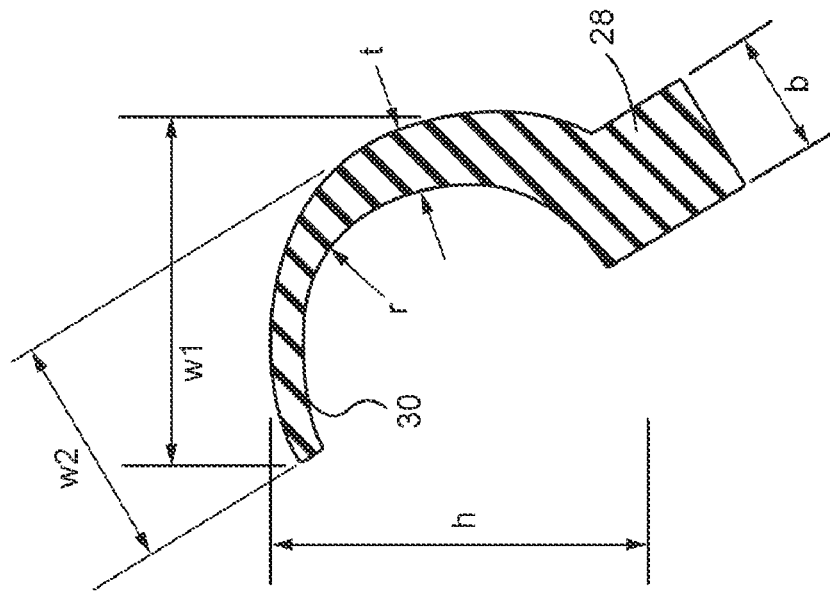

Fig. 23

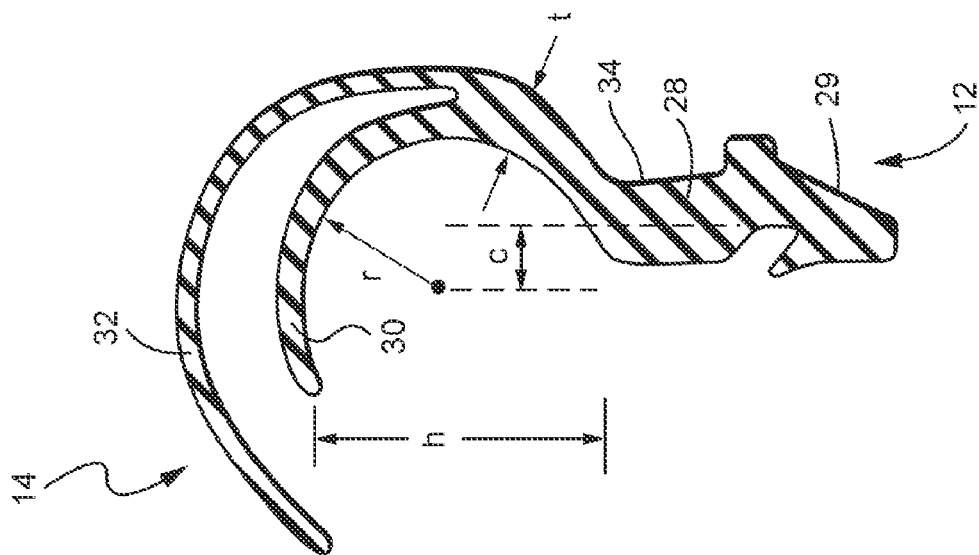

Fig. 22

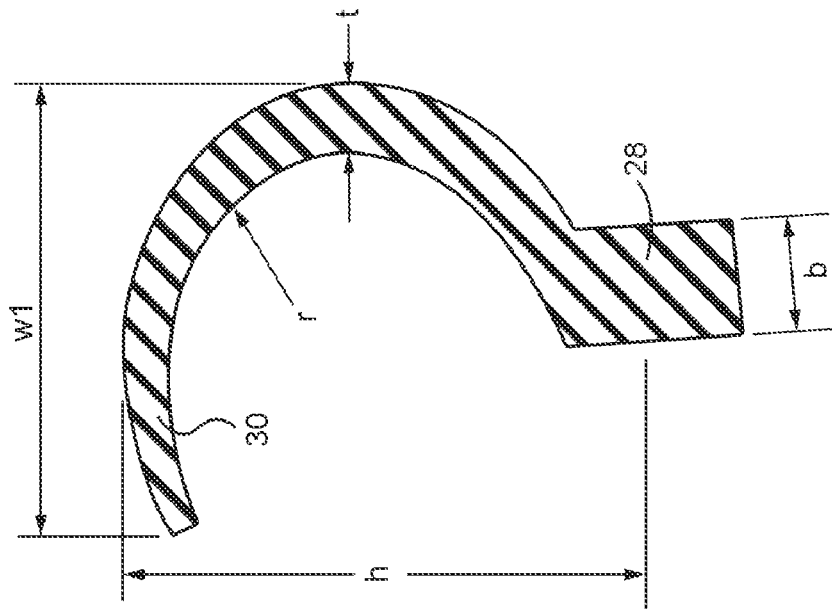

Fig. 25

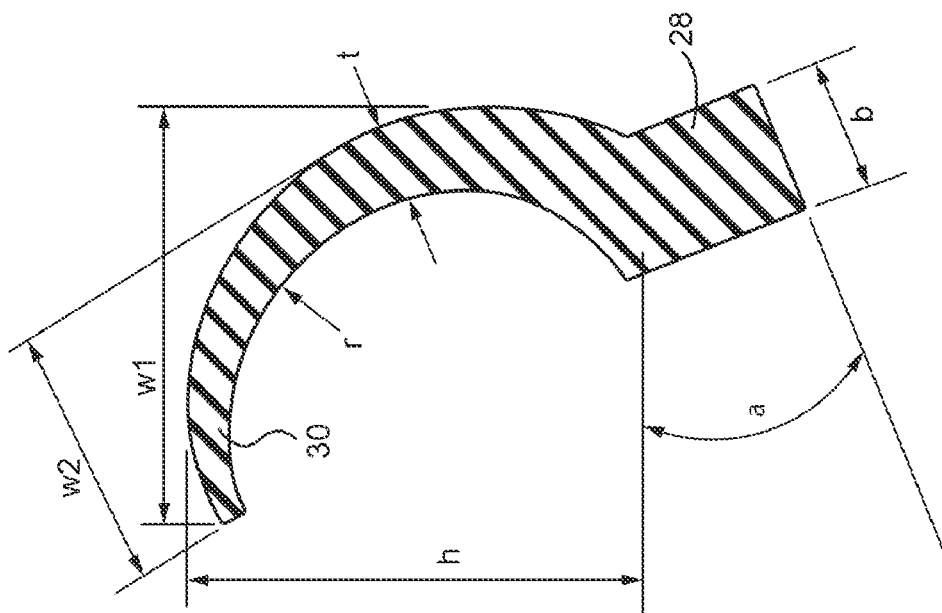

Fig. 24

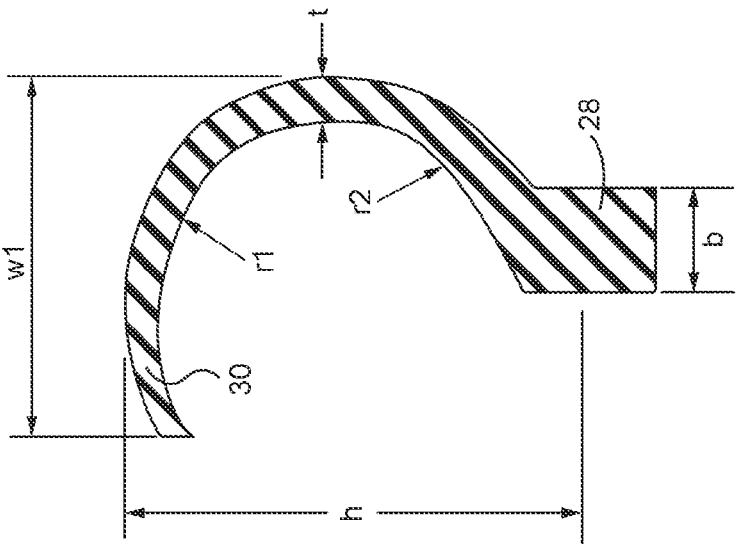

Fig. 27

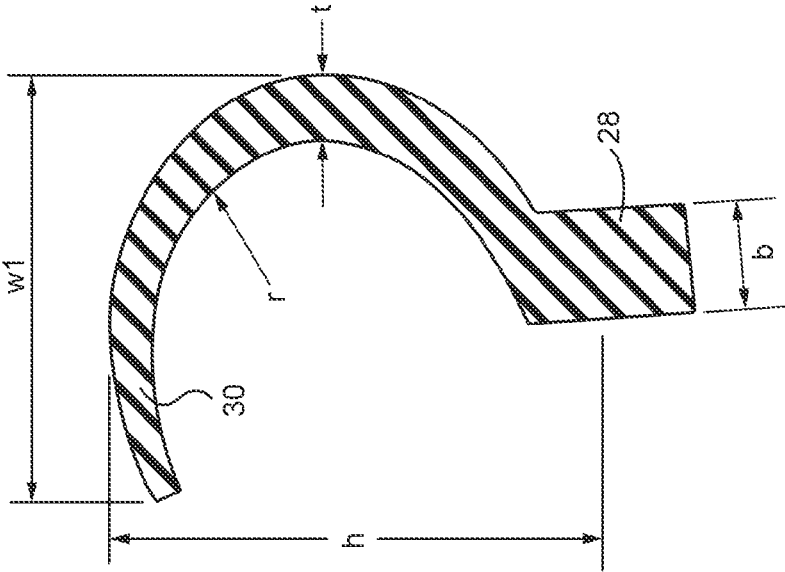

Fig. 26

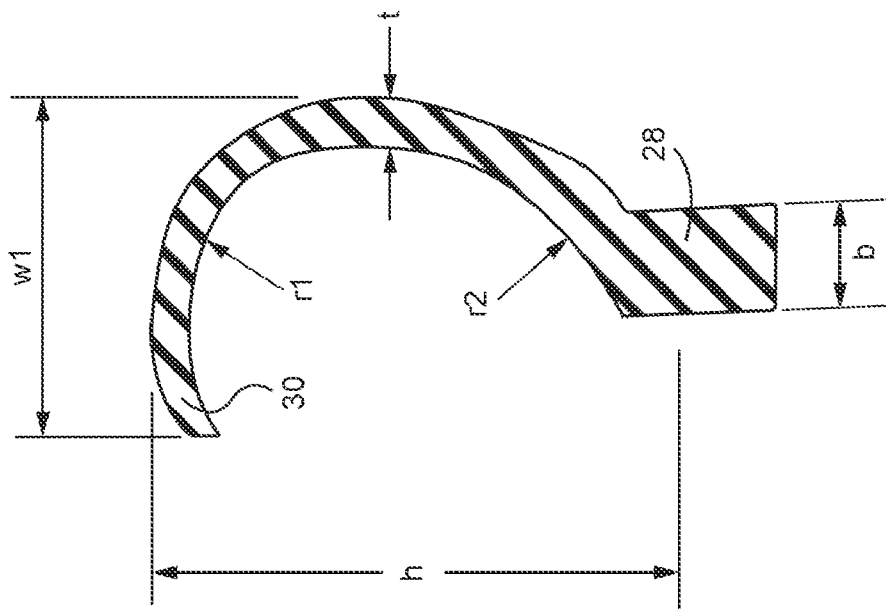

Fig. 29

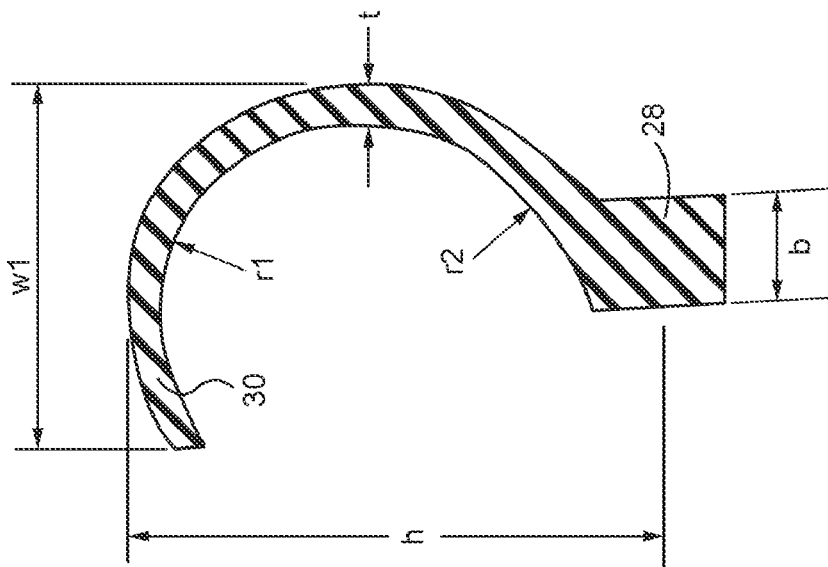

Fig. 28

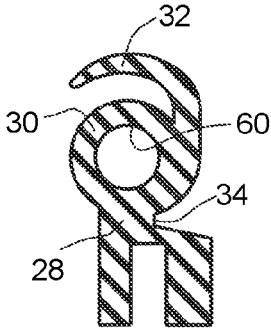

Fig. 30A

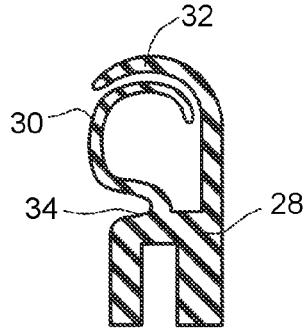

Fig. 30B

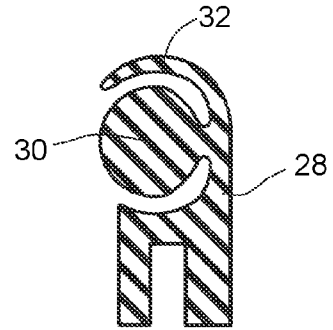

Fig. 30C

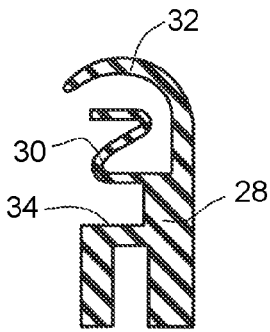

Fig. 30D

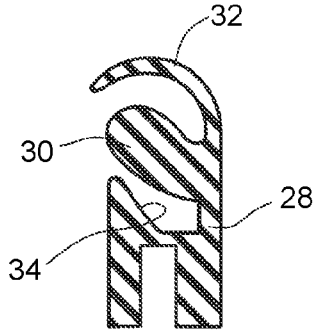

Fig. 30E

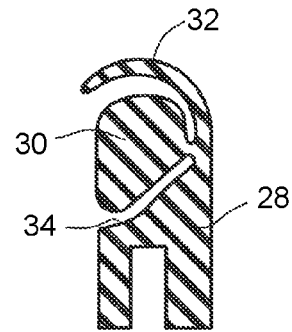

Fig. 30F

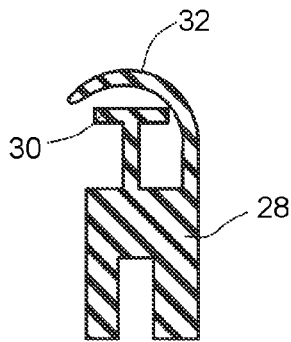

Fig. 30G

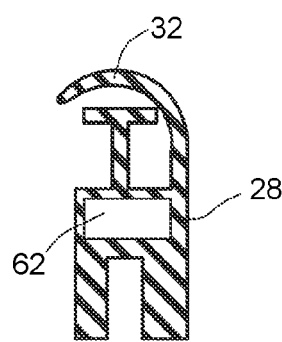

Fig. 30H

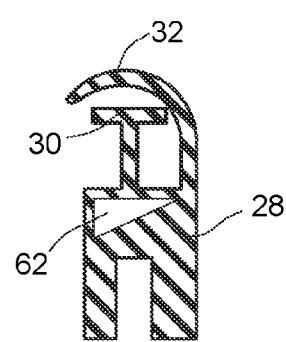

Fig. 30I

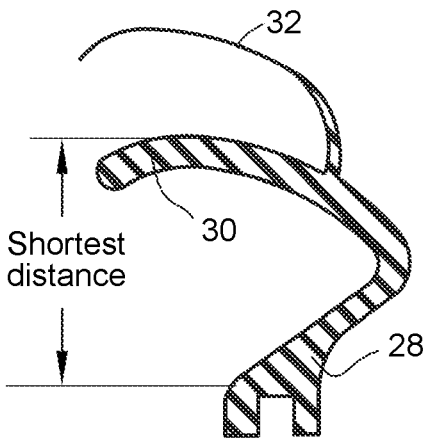

Fig. 30J

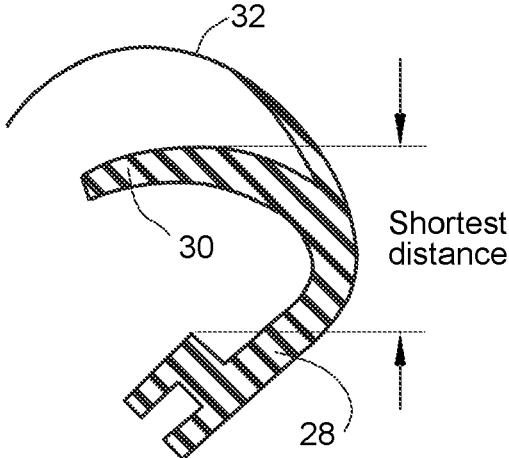

Fig. 30K

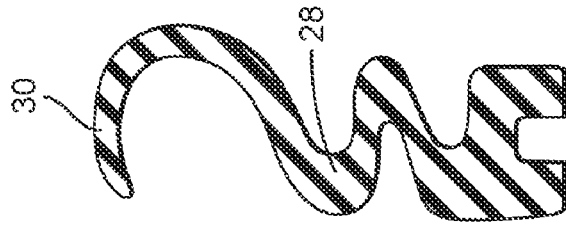

Fig. 30N

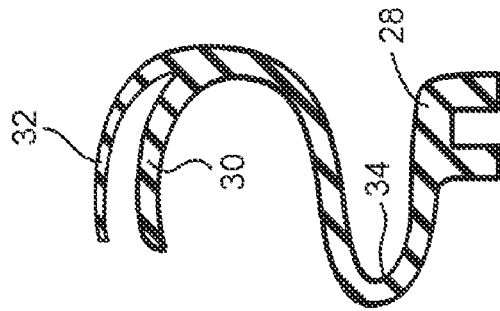

Fig. 30M

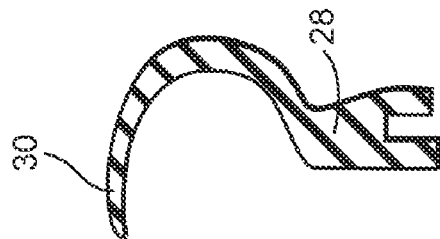

Fig. 30L

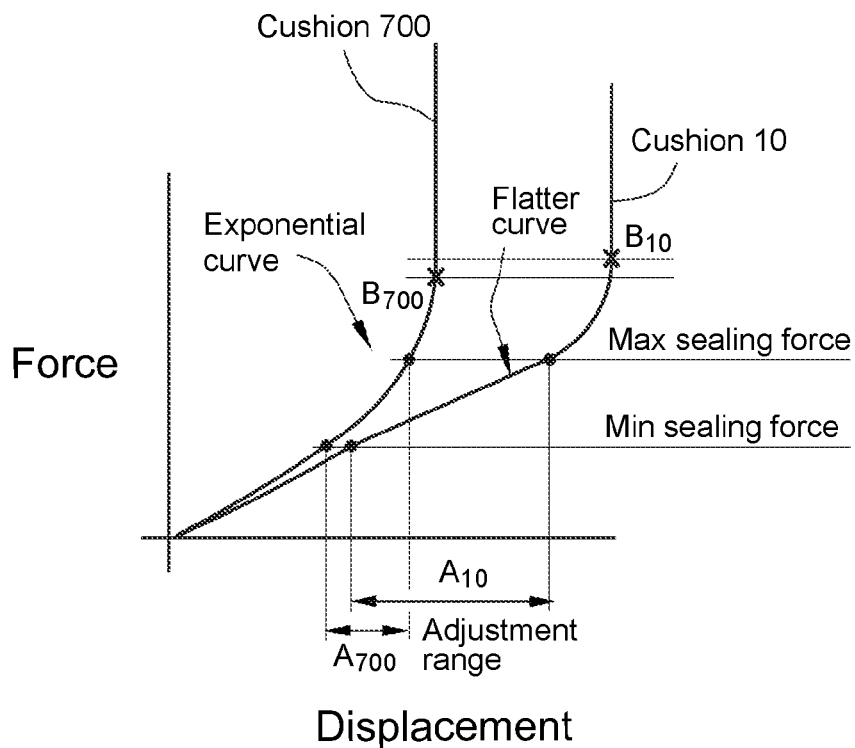

Fig. 31

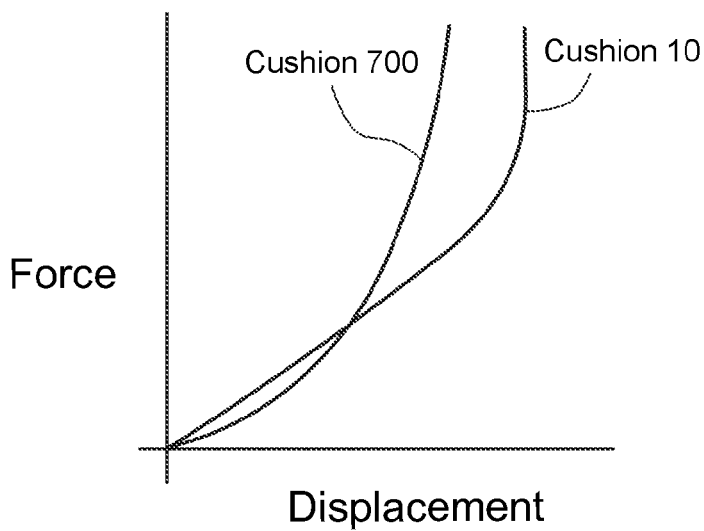

Fig. 32

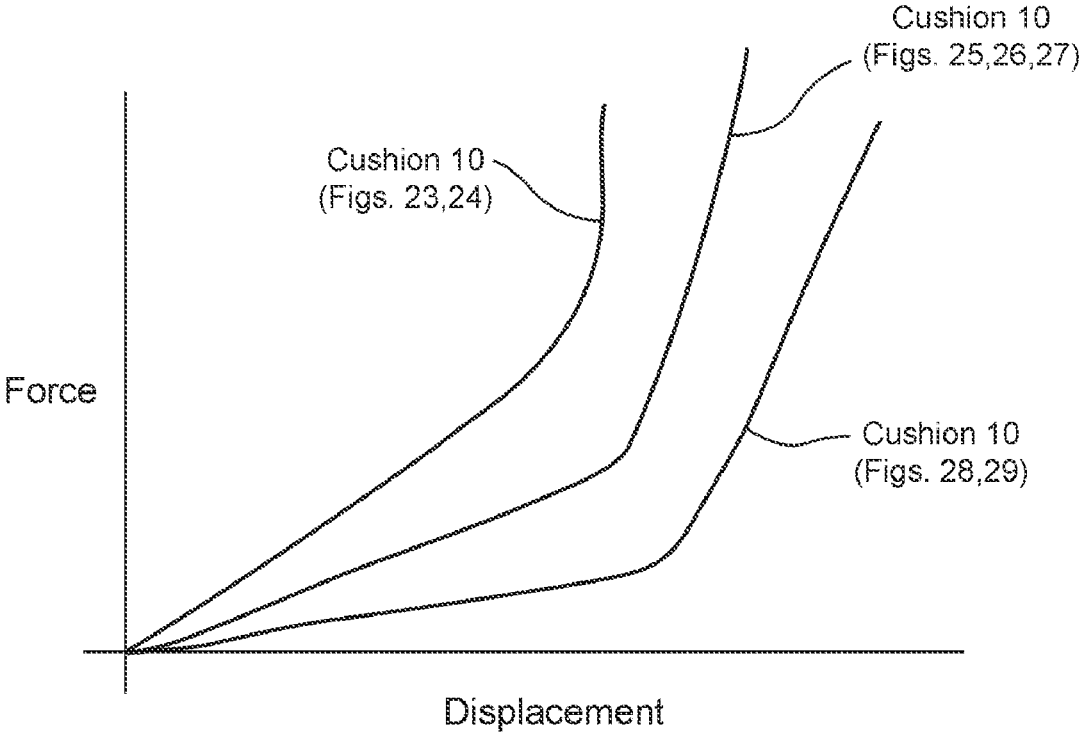
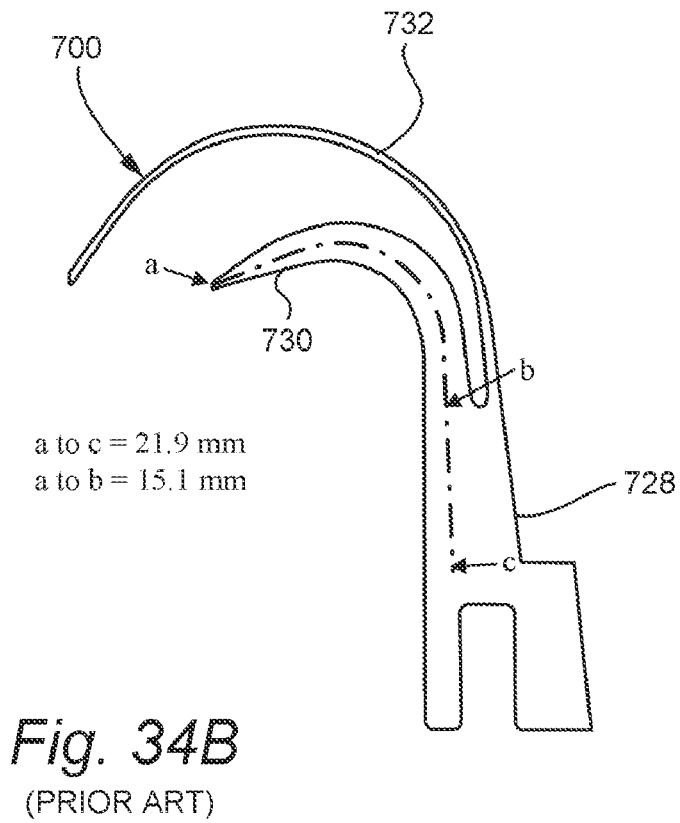
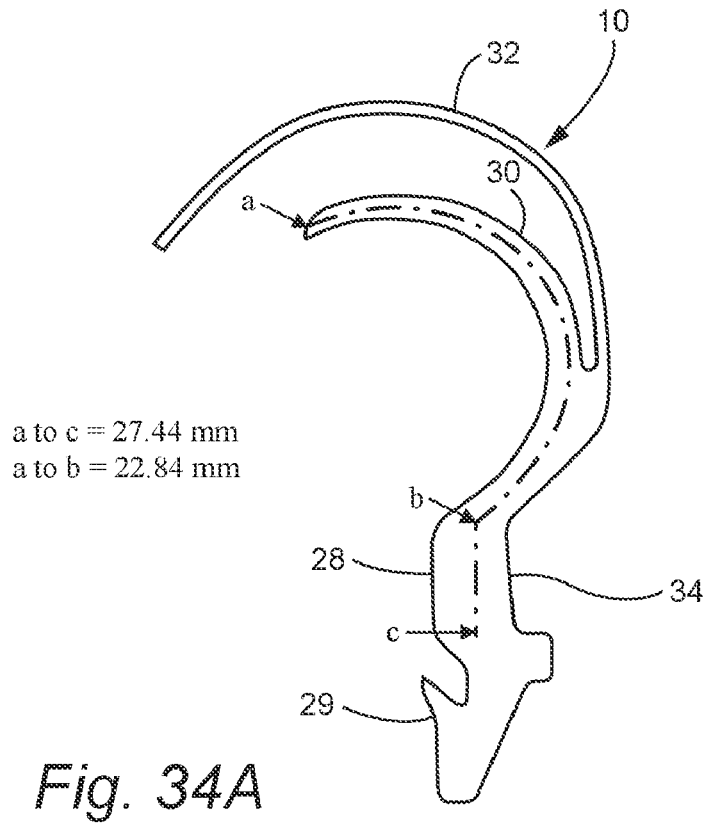

Fig. 33



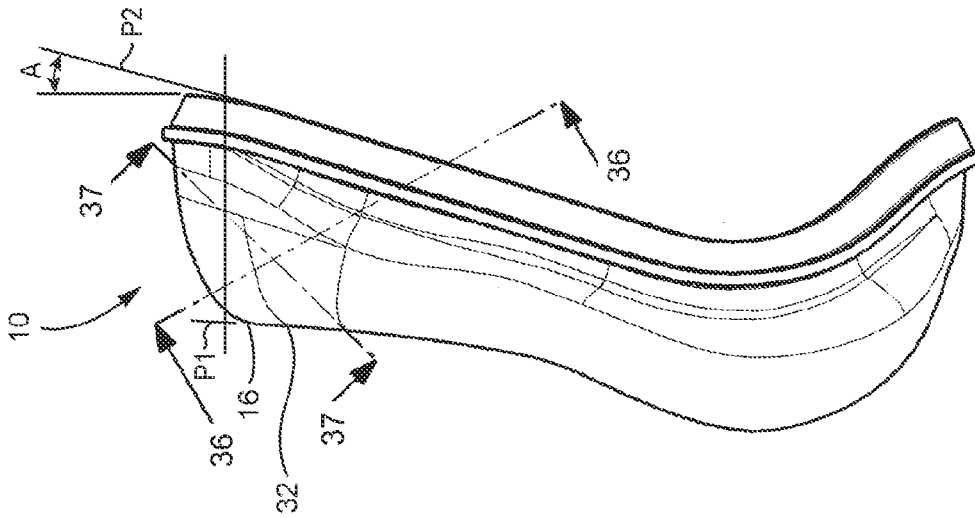

Fig. 35

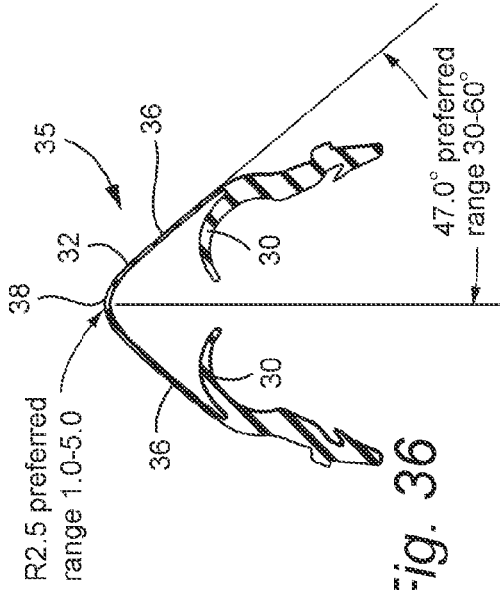

Fig. 36

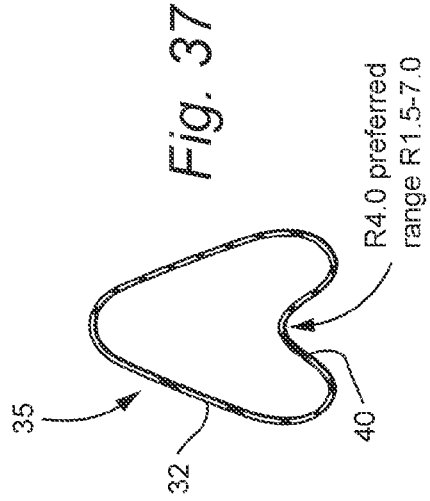

Fig. 37

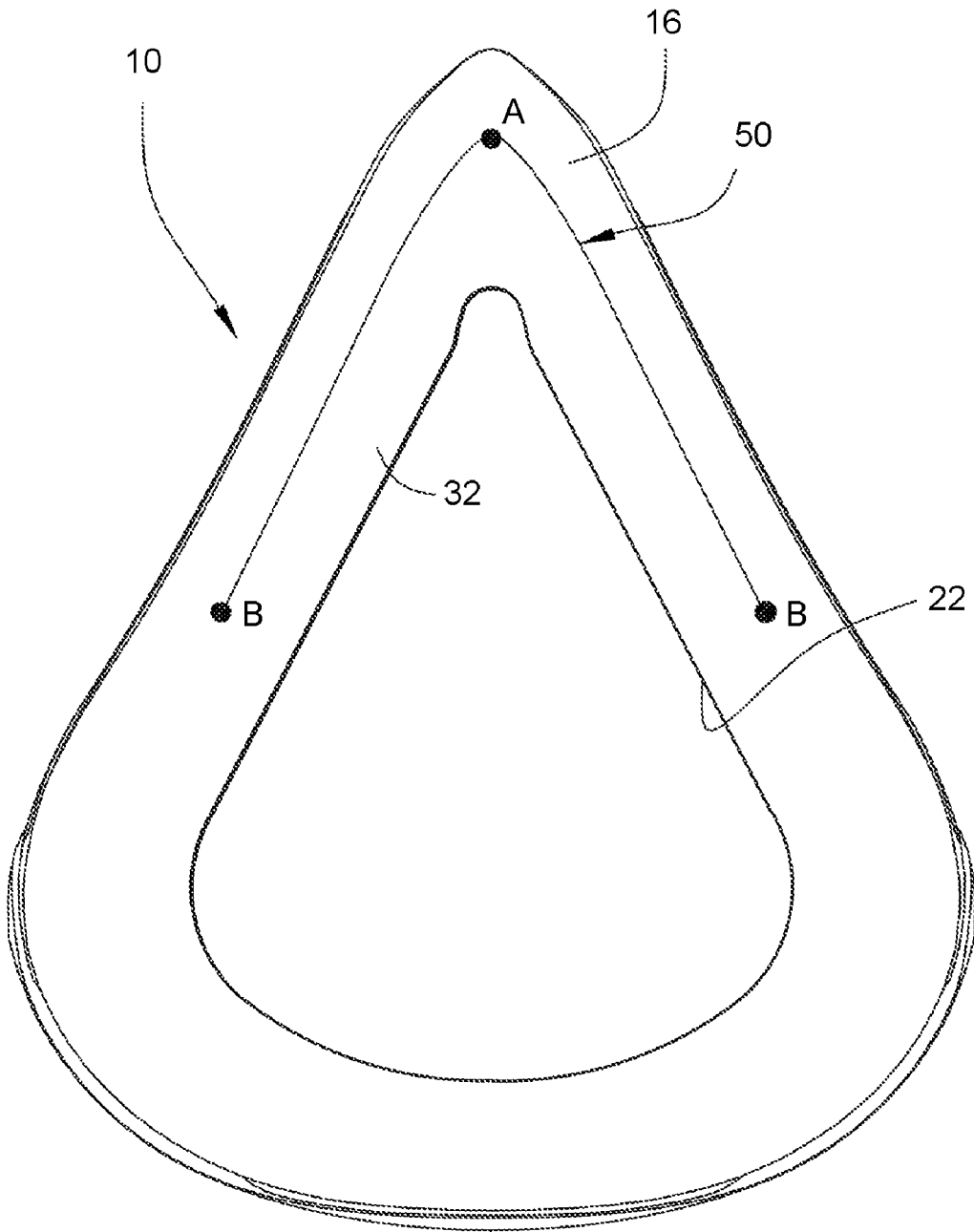

Fig. 38

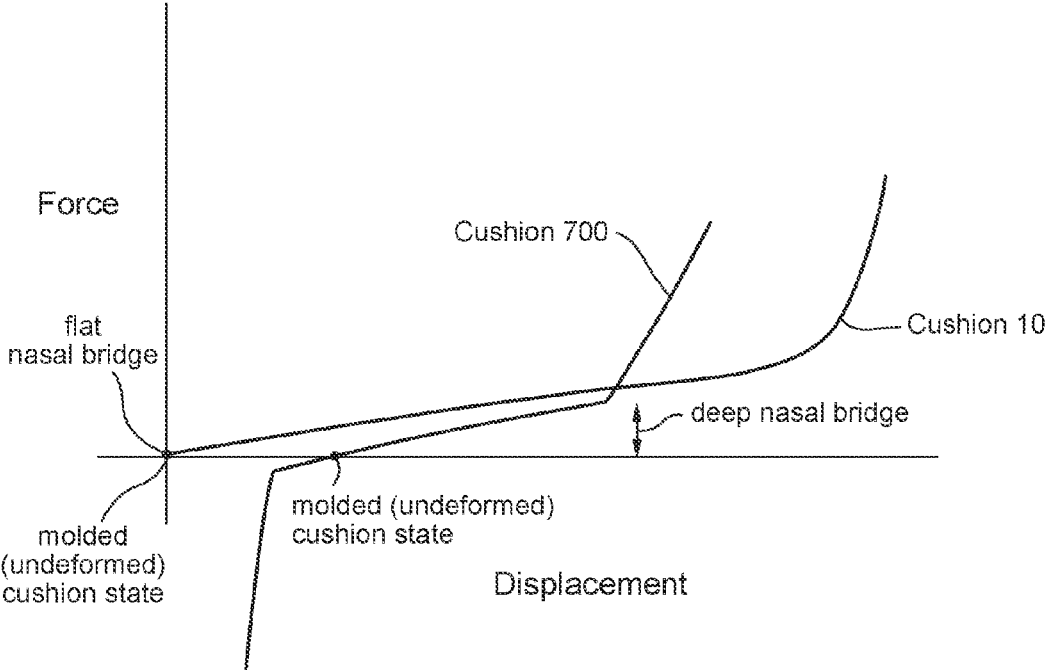

Fig. 38B

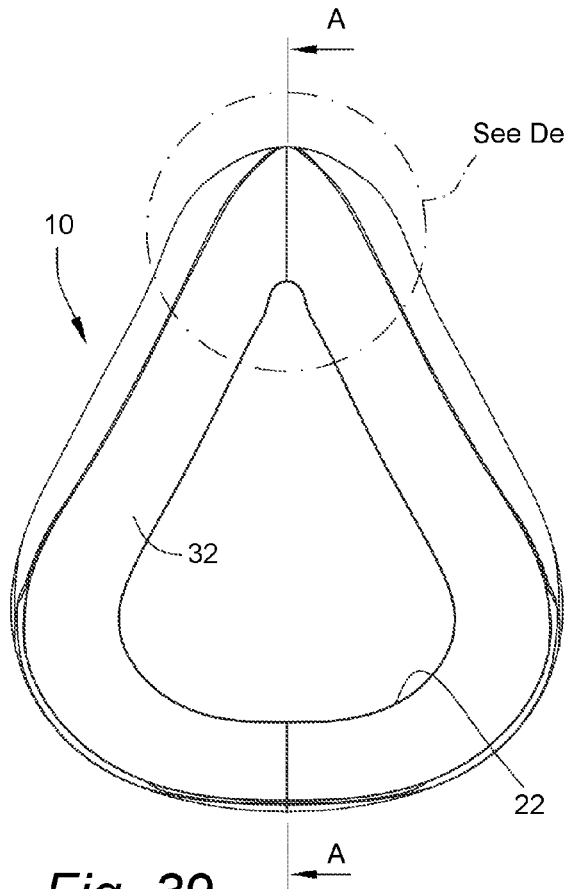
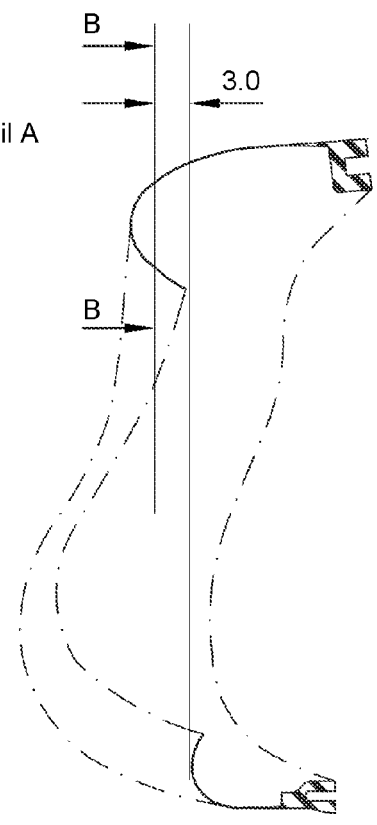
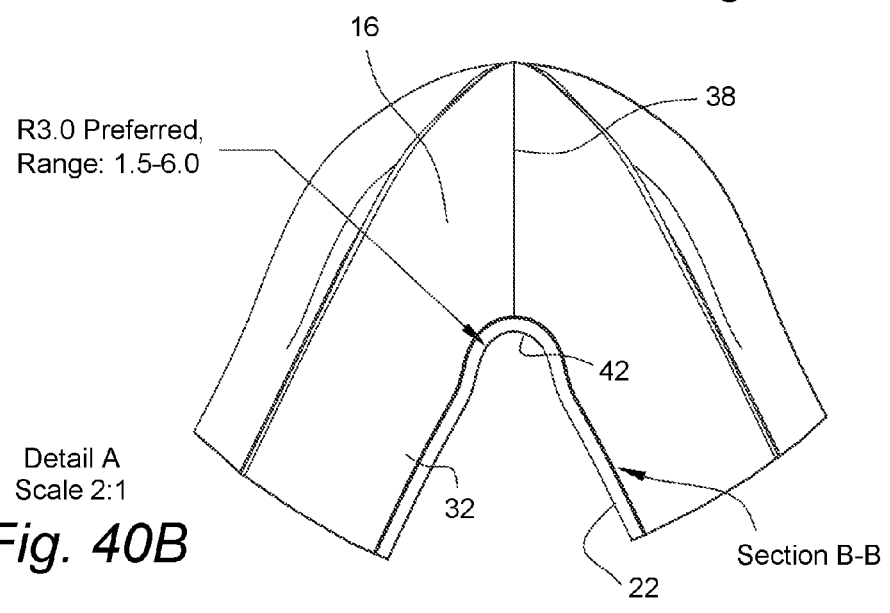

Fig. 39



Section A-A
Fig. 40A



Detail A
Scale 2:1
Fig. 40B

Section B-B

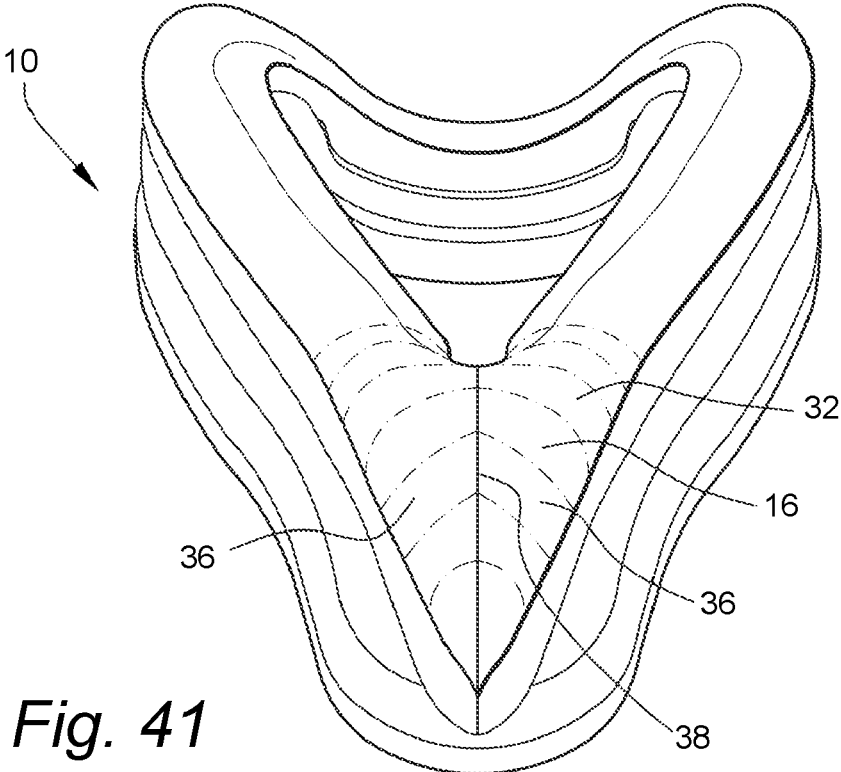

Fig. 41

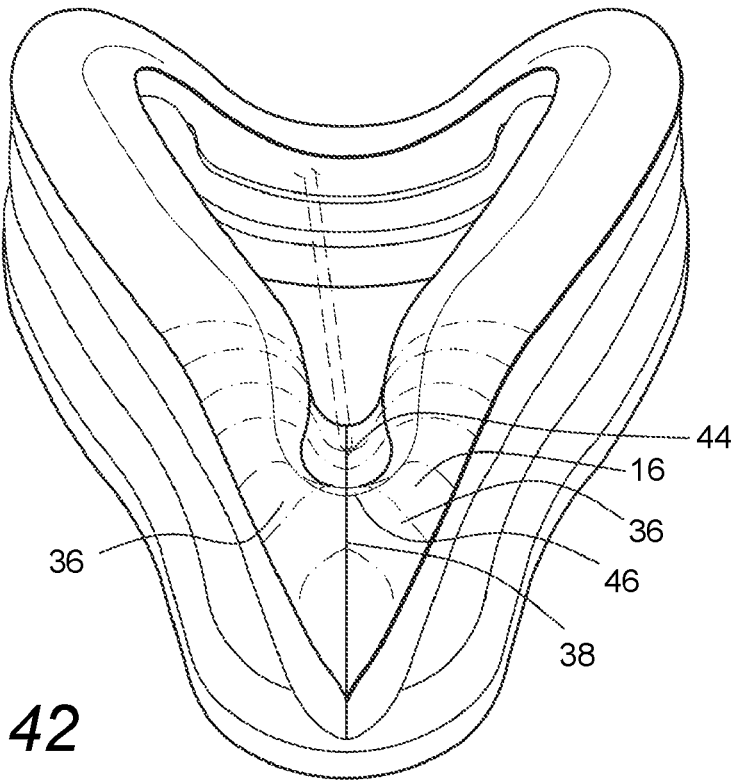

Fig. 42

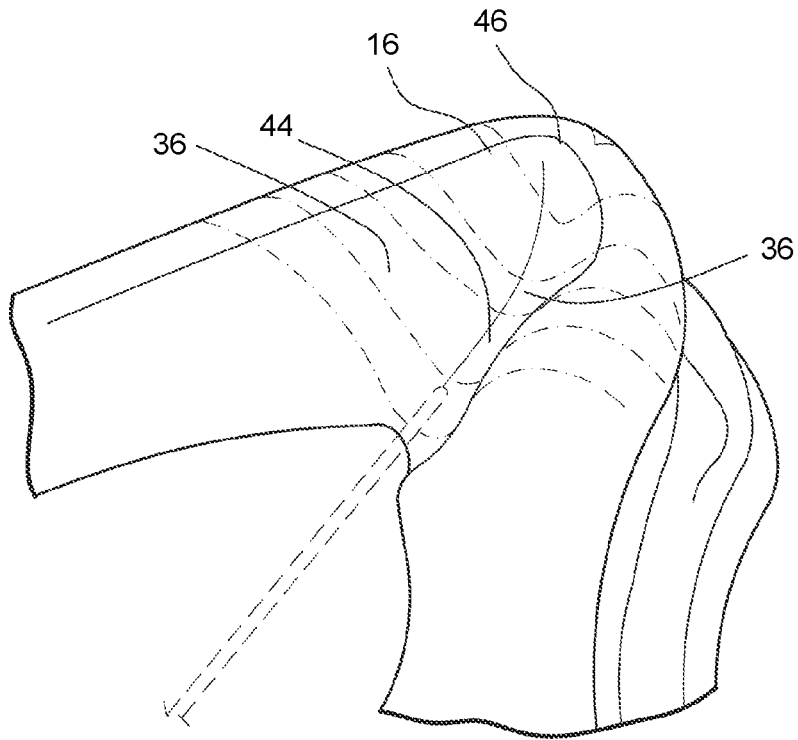

Fig. 43

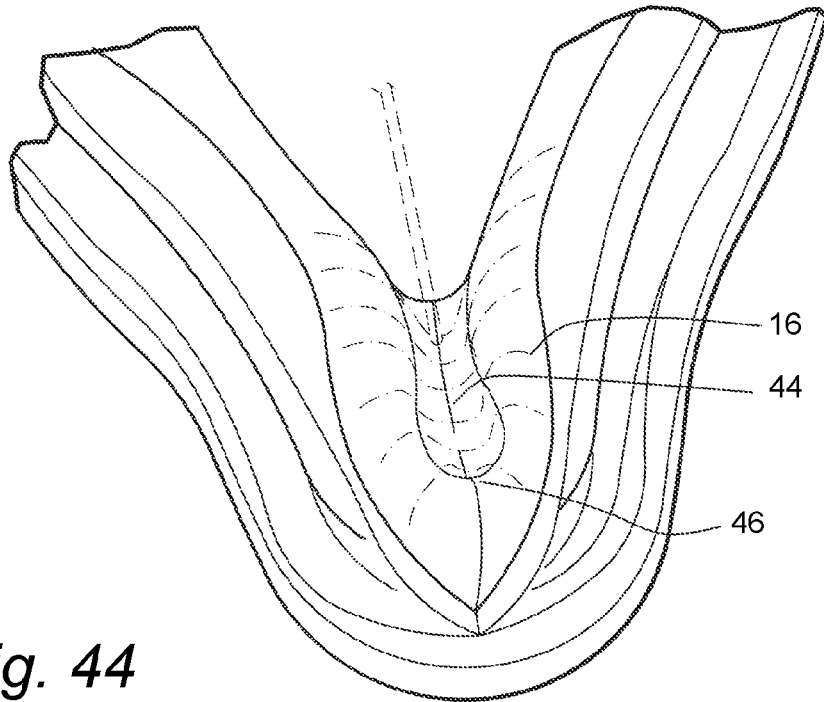

Fig. 44

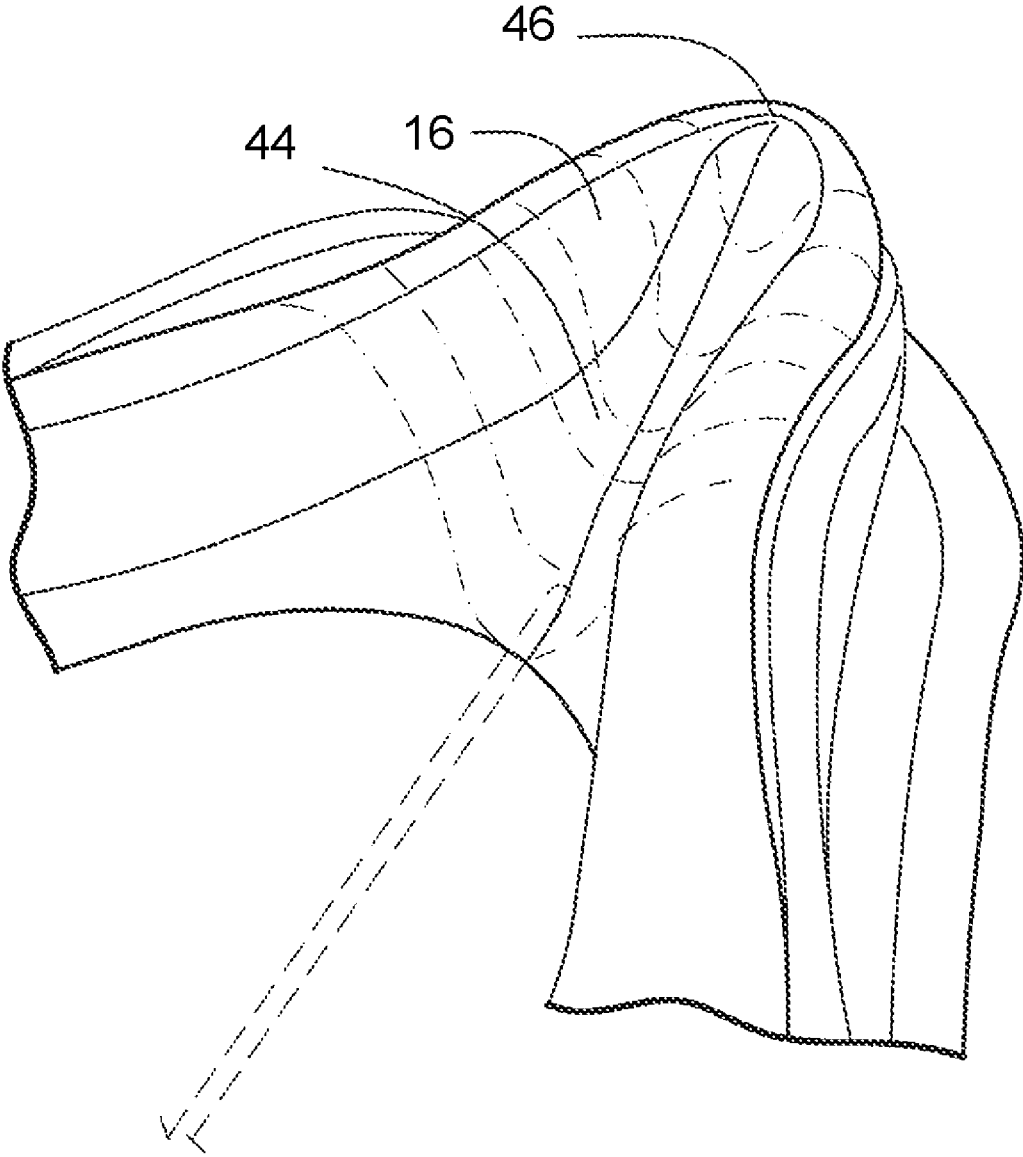

Fig. 45

Fig. 47
(Prior Art)

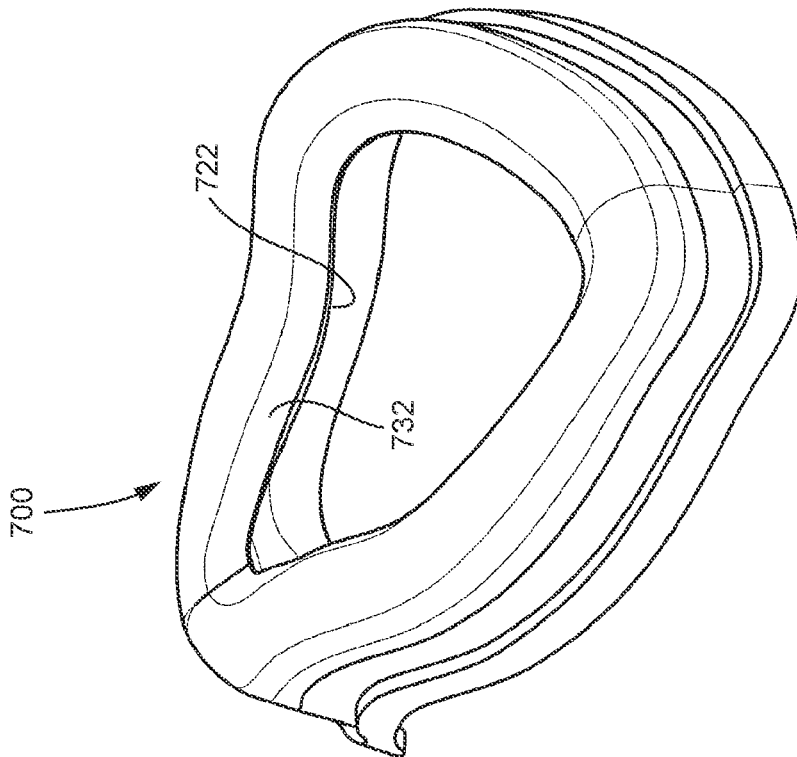
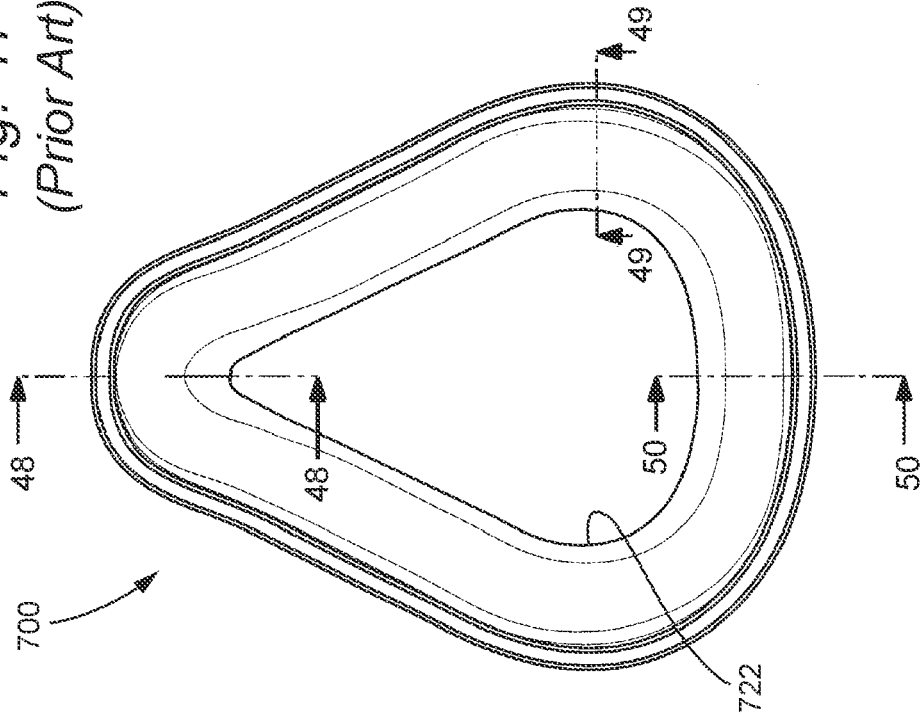

Fig. 46
(Prior Art)

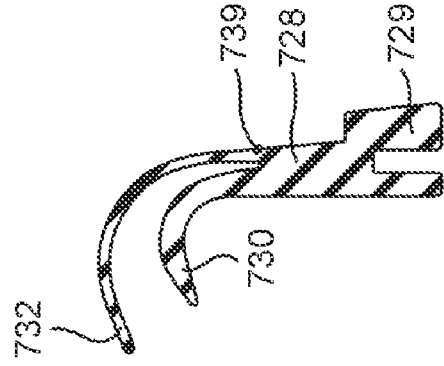

Fig. 49
(Prior Art)

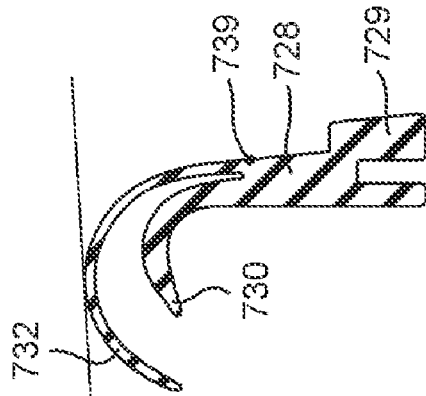

Fig. 50
(Prior Art)

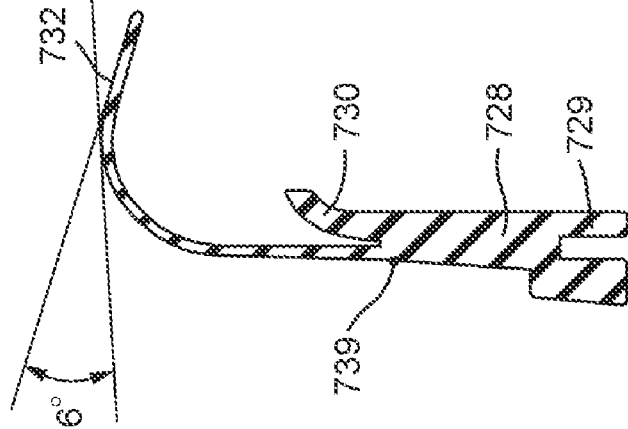

Fig. 48
(Prior Art)

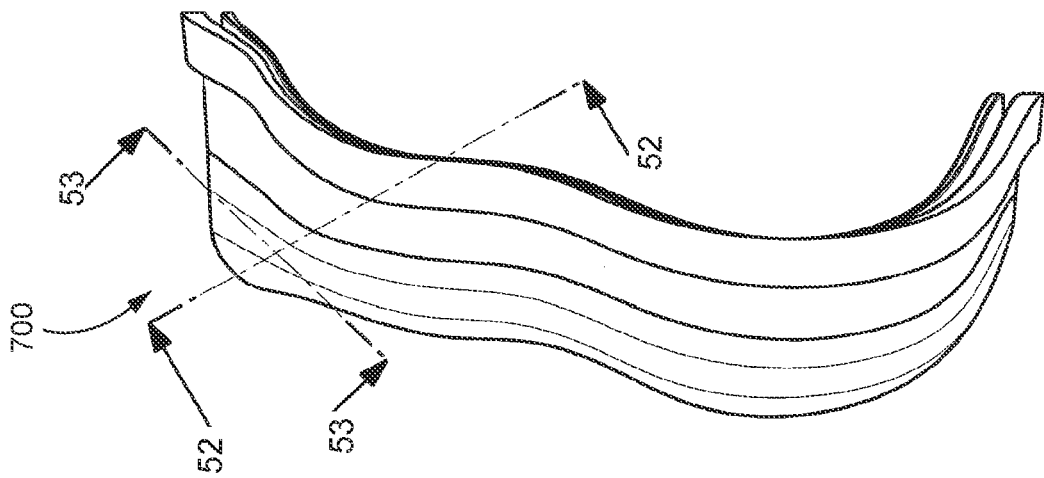

Fig. 51
(Prior Art)

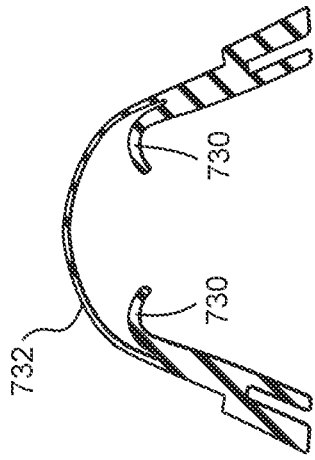

Fig. 52
(Prior Art)

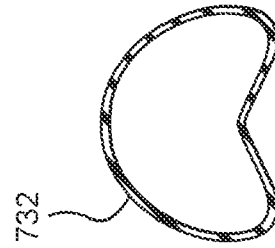

Fig. 53
(Prior Art)

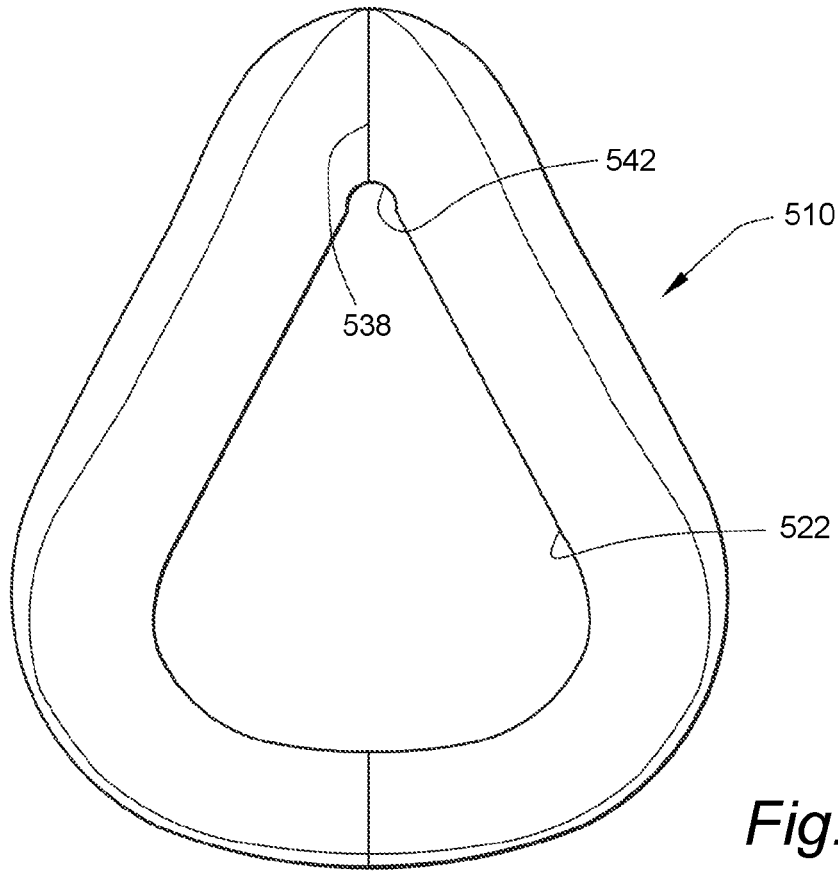

Fig. 54

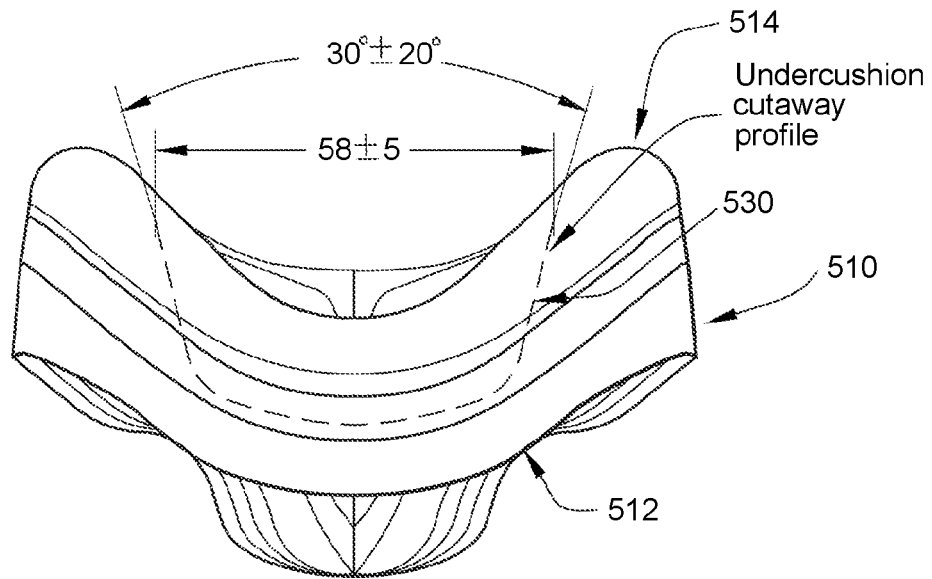

Fig. 55

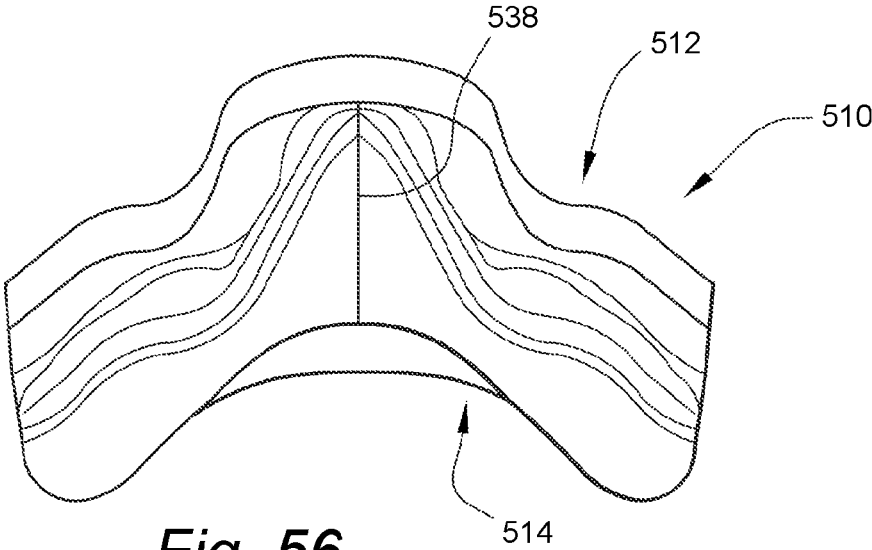

Fig. 56

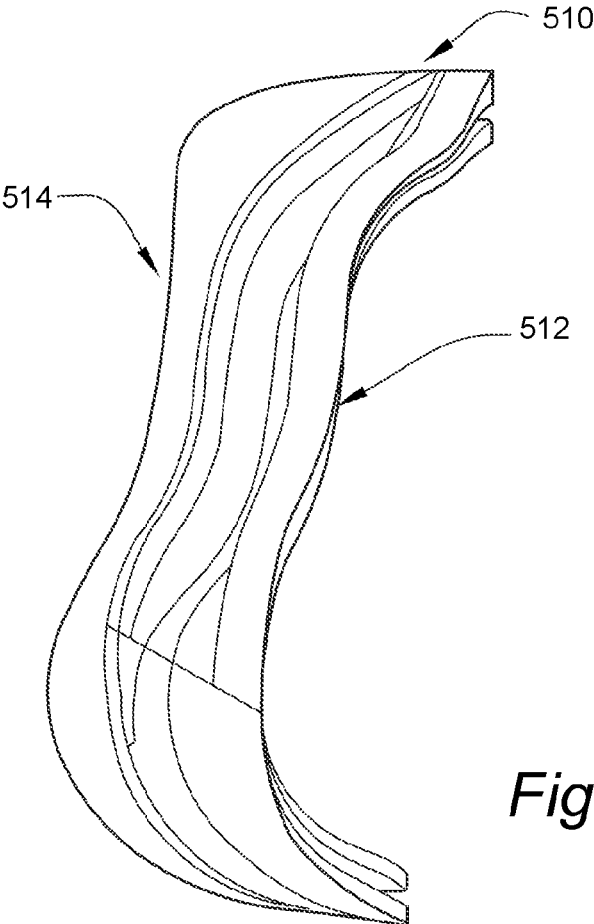

Fig. 57

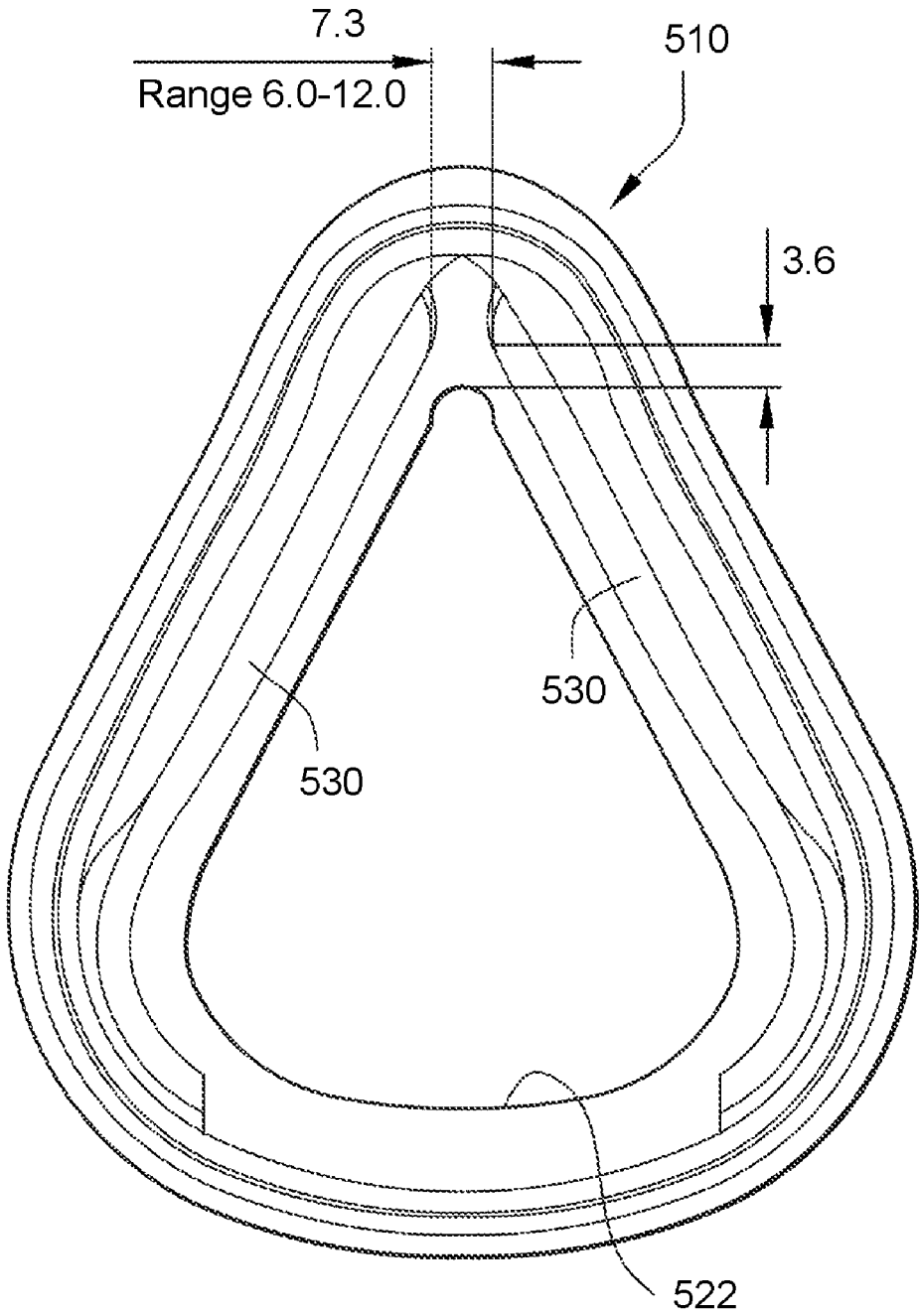

Fig. 58

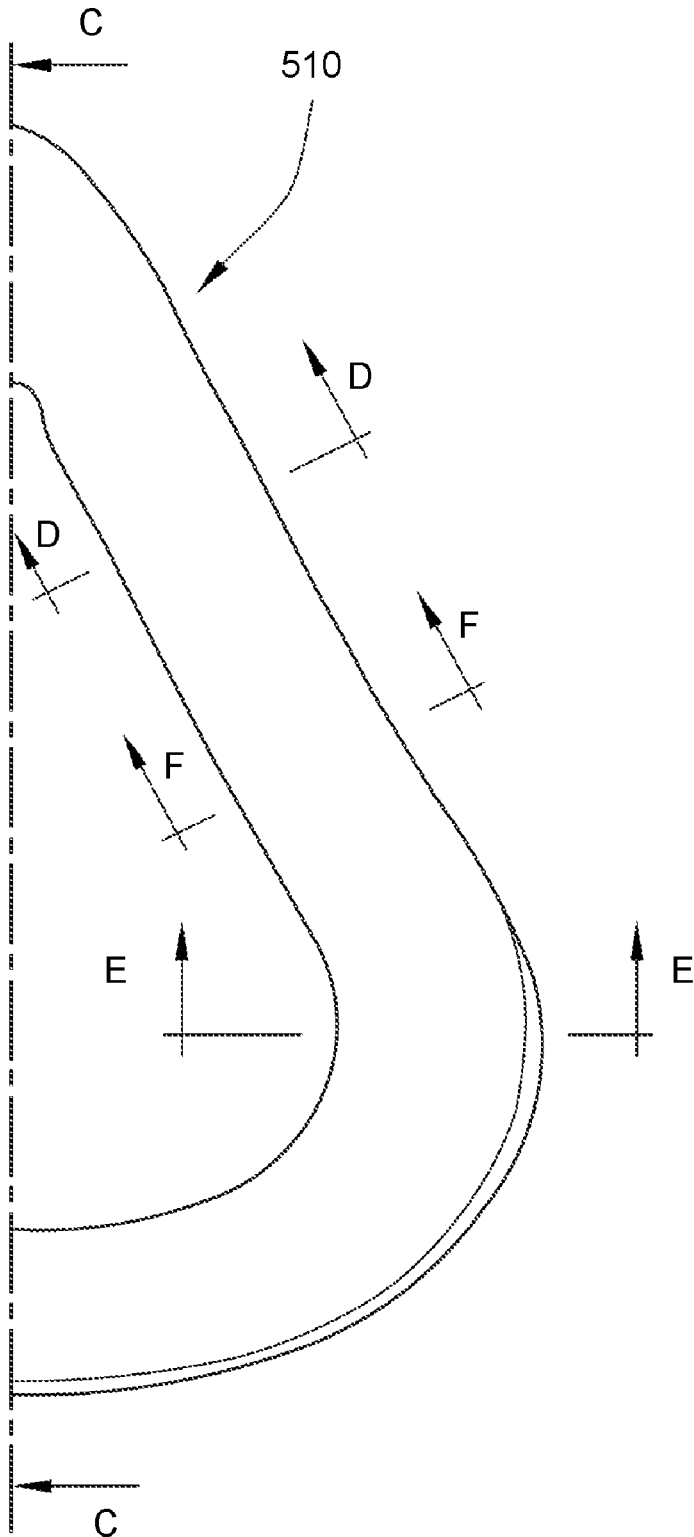
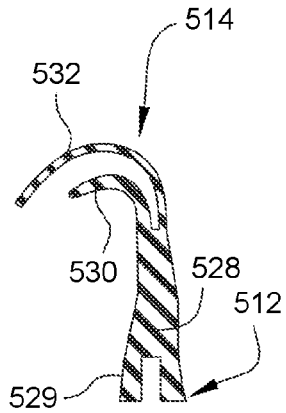
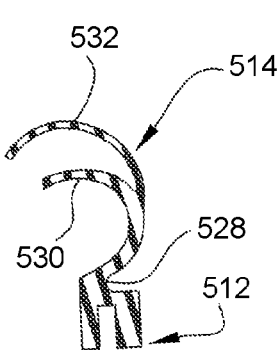
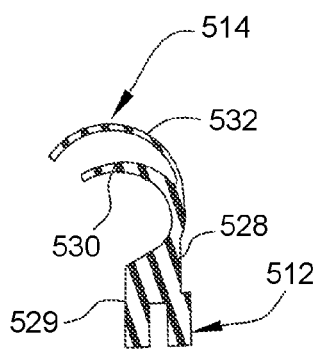
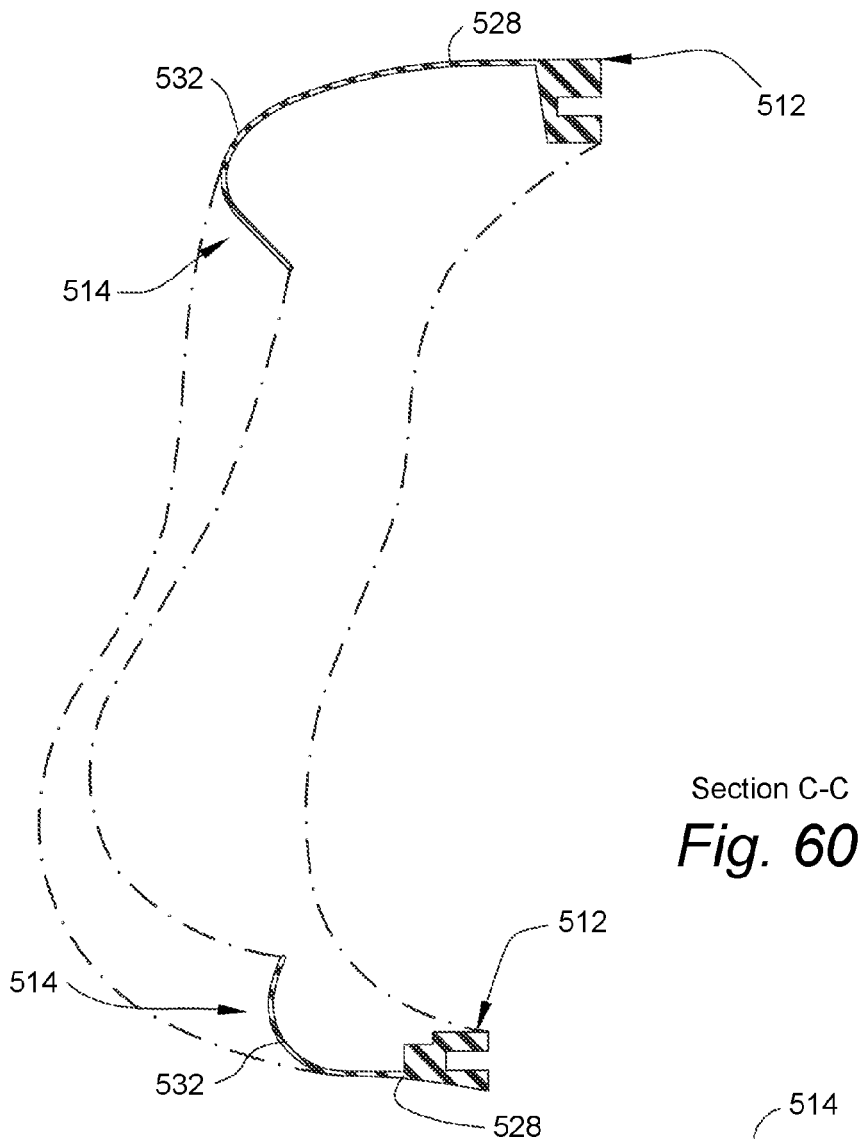

Fig. 59



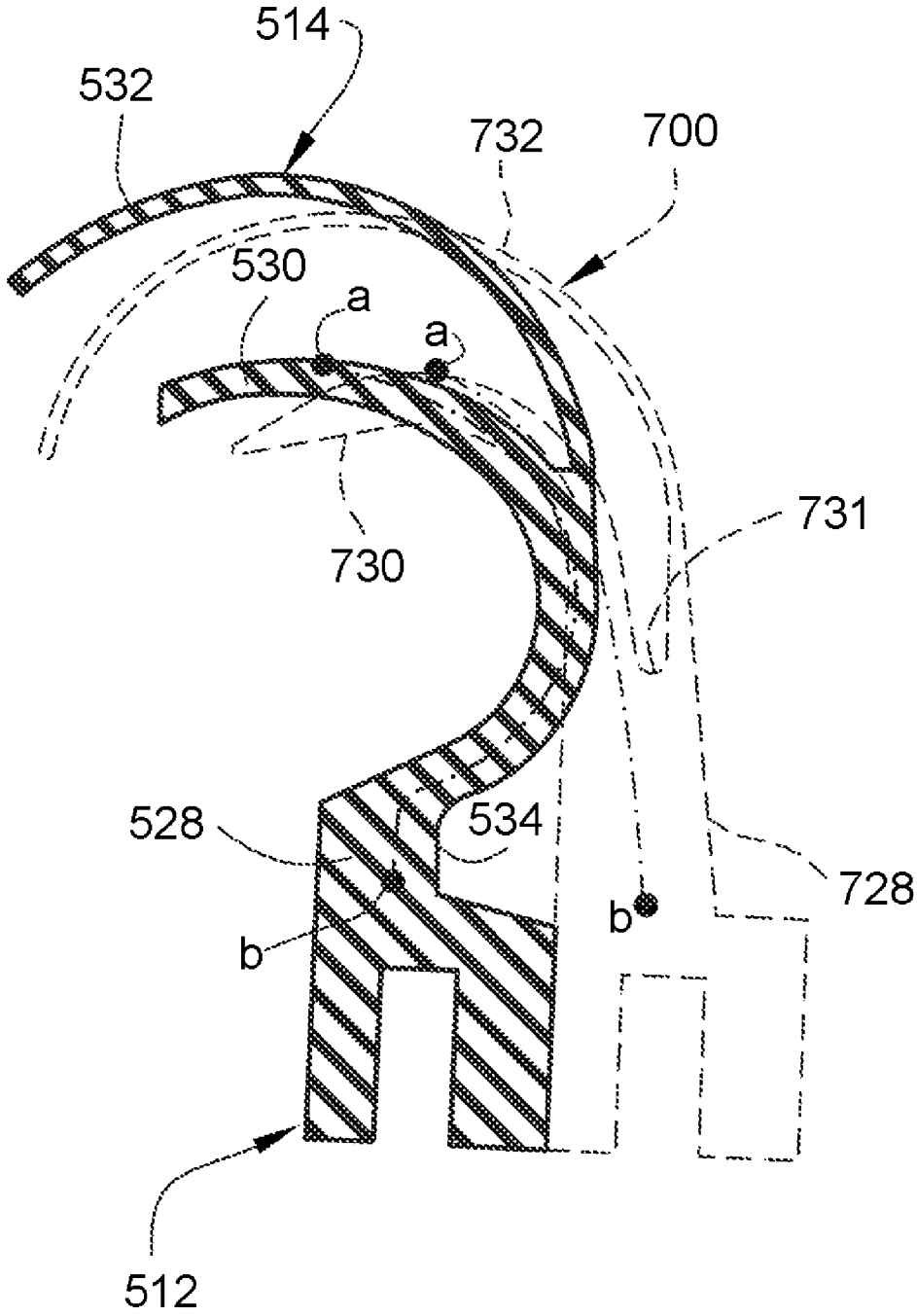

Fig. 64

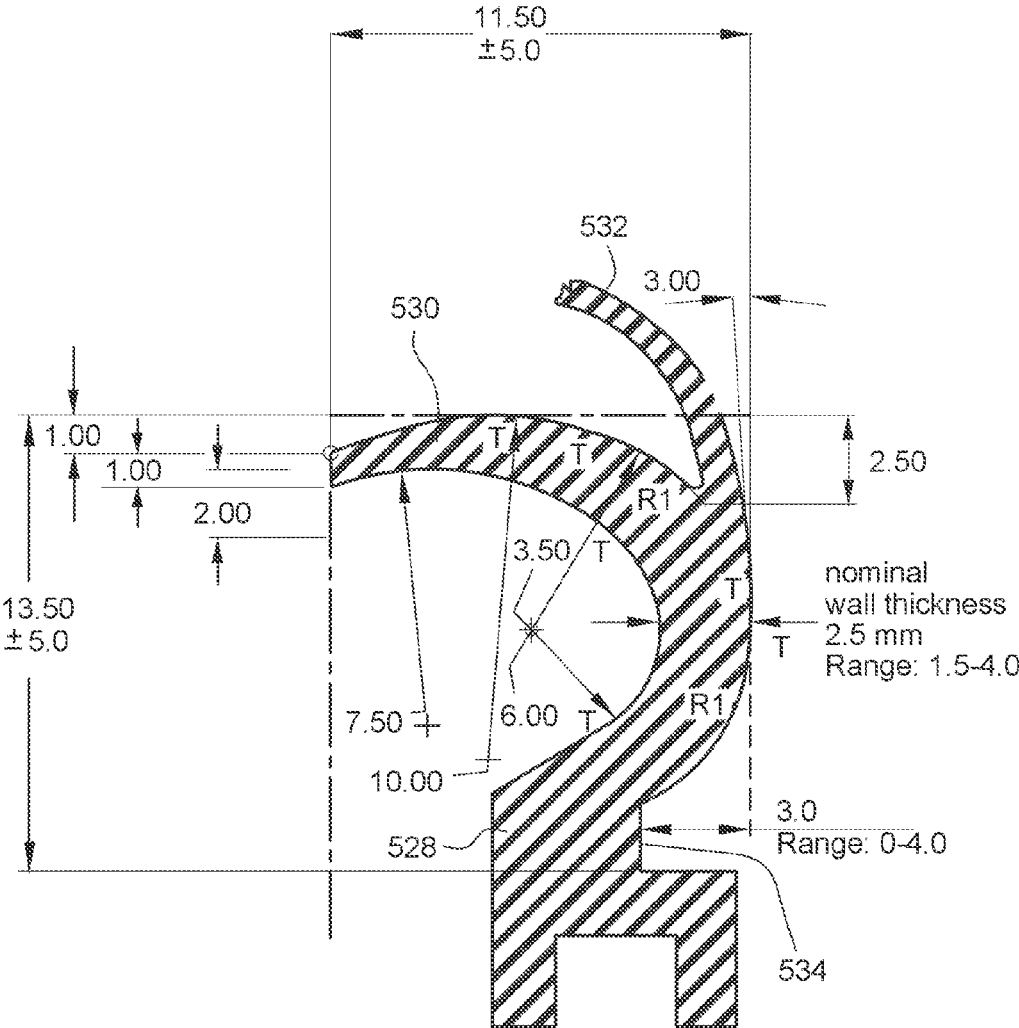
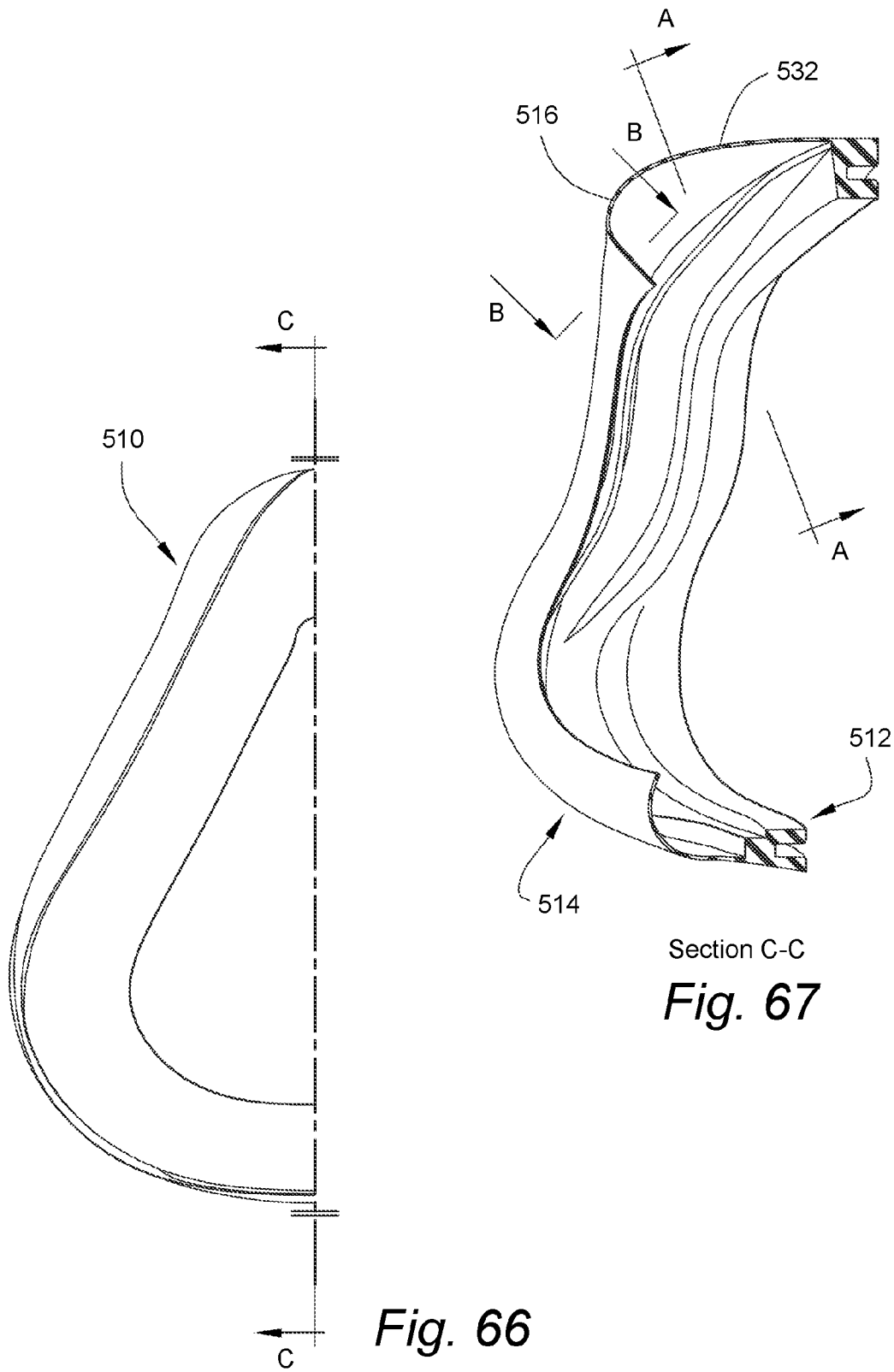

Fig. 65



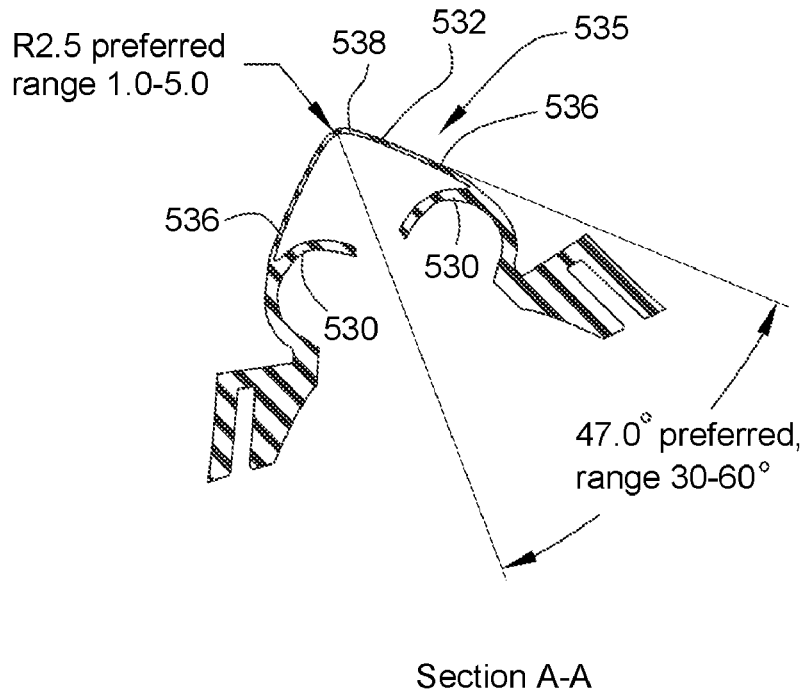

Fig. 68

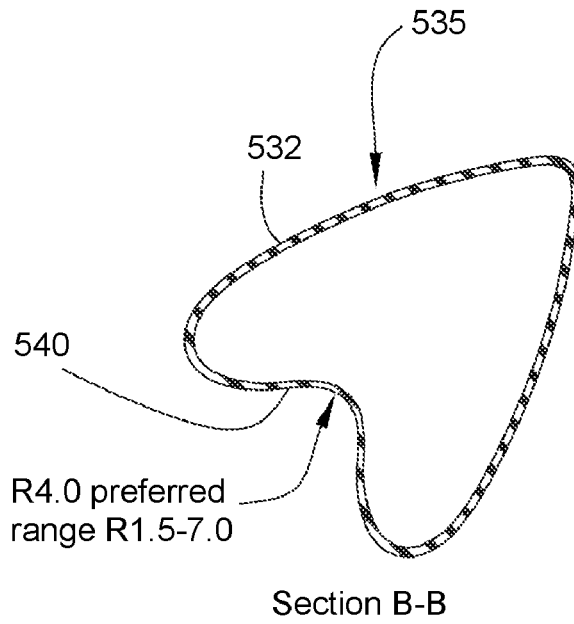

Fig. 69

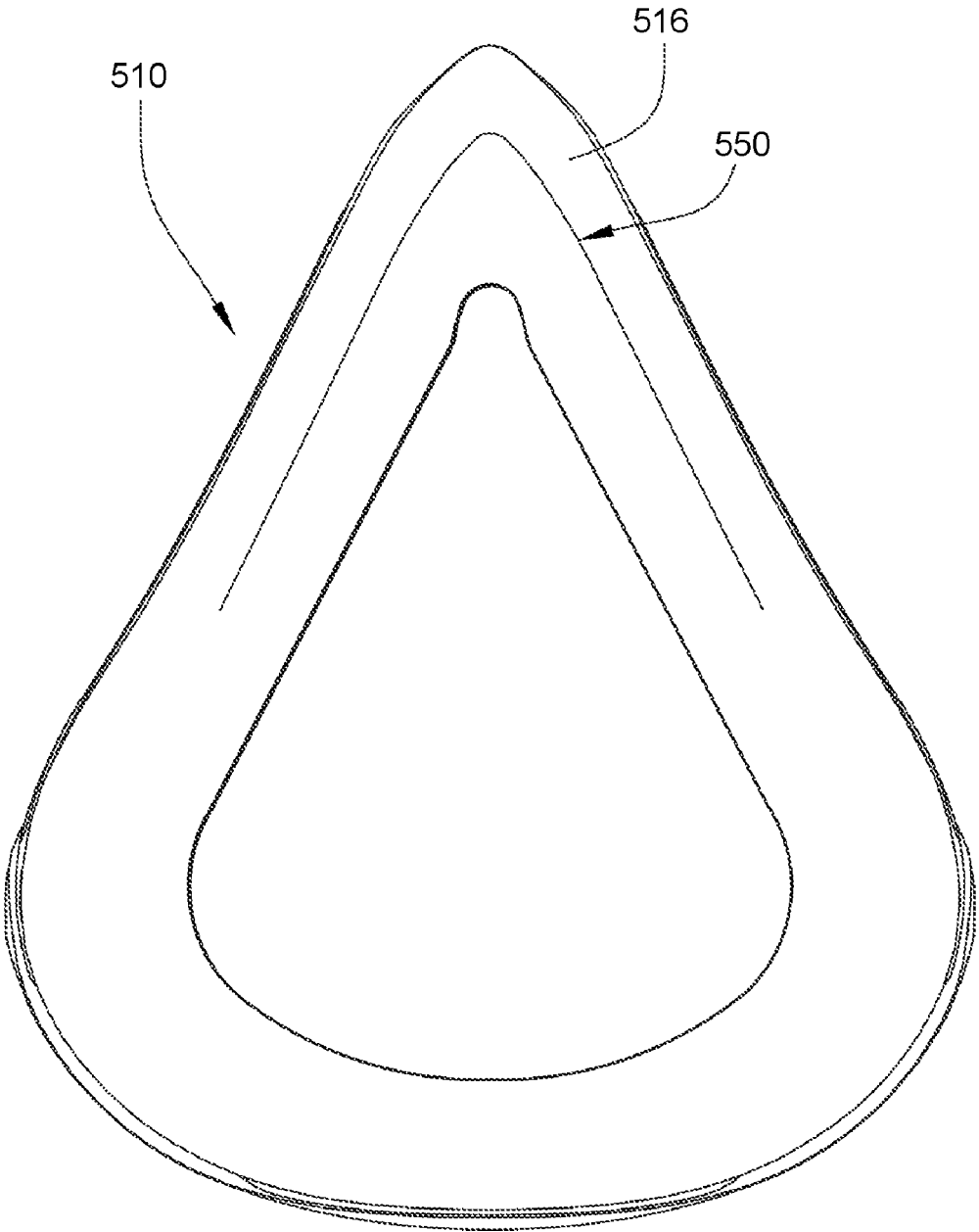
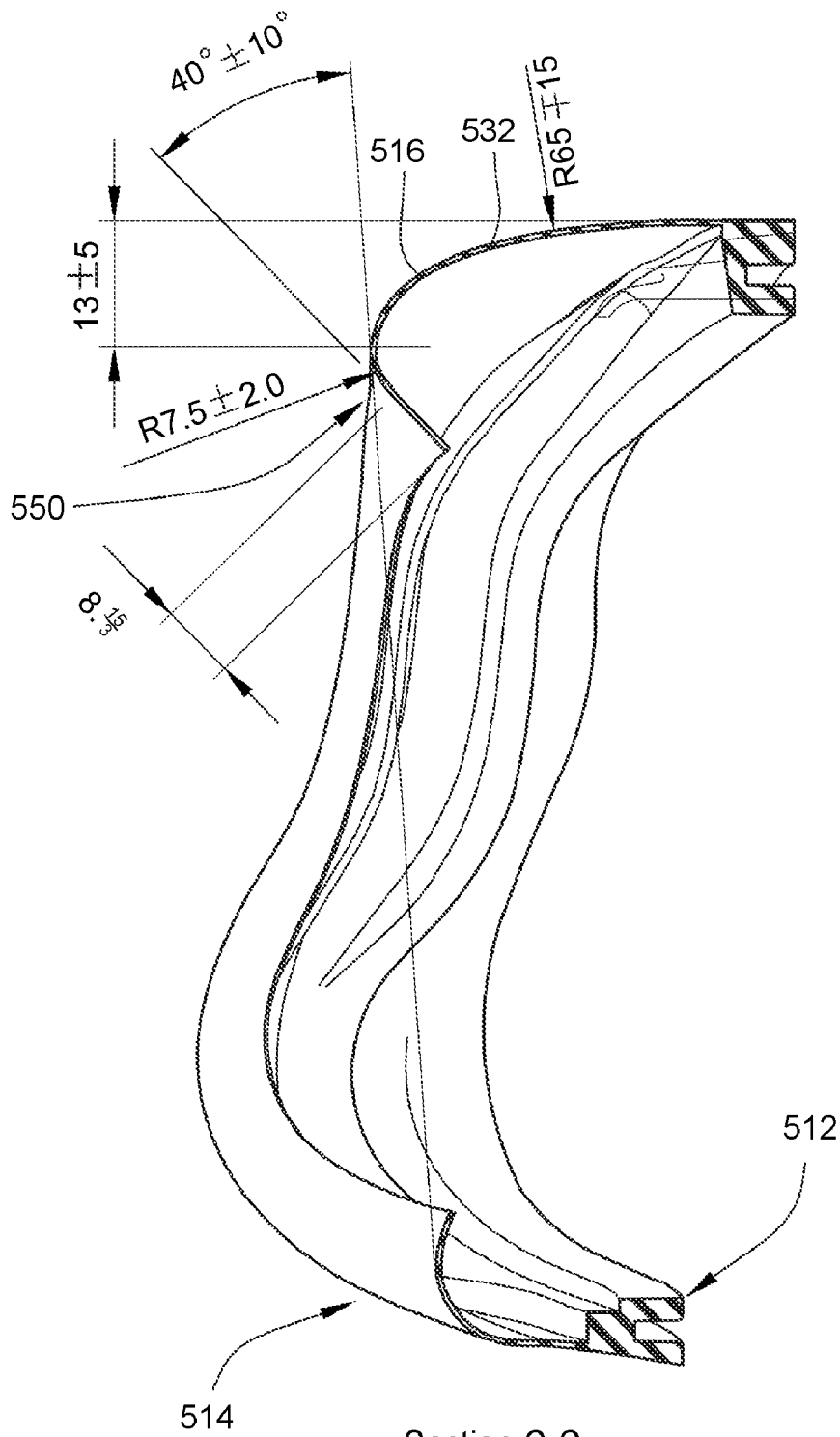

Fig. 70



Section C-C

Fig. 71

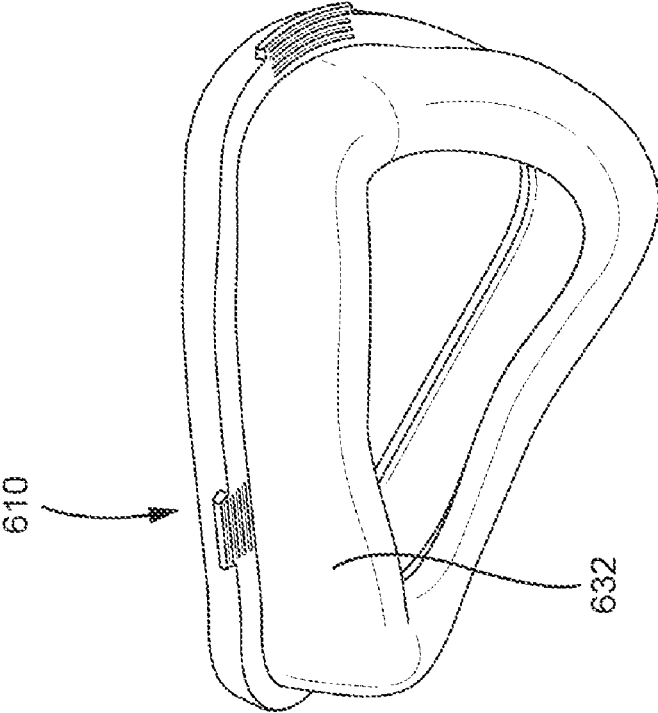

Fig. 73

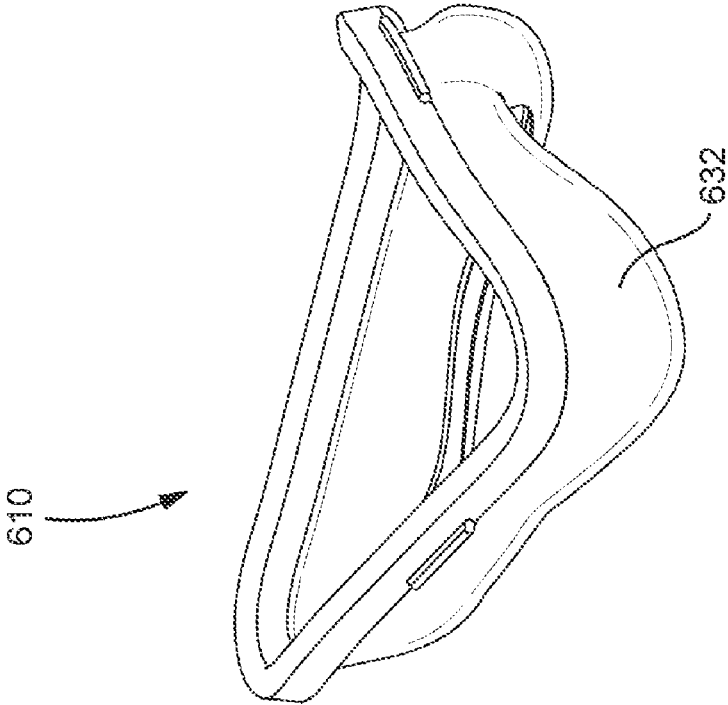
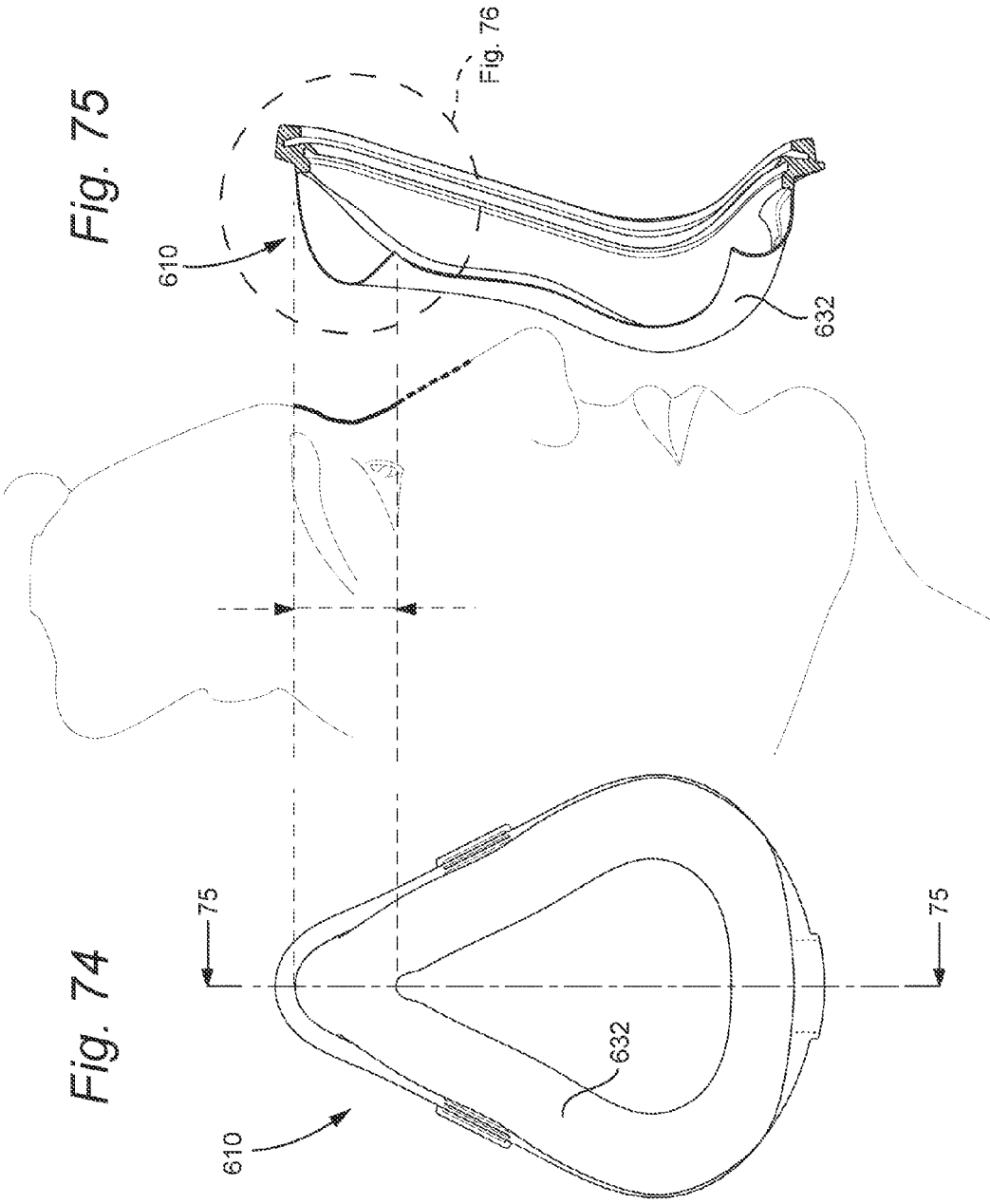

Fig. 72



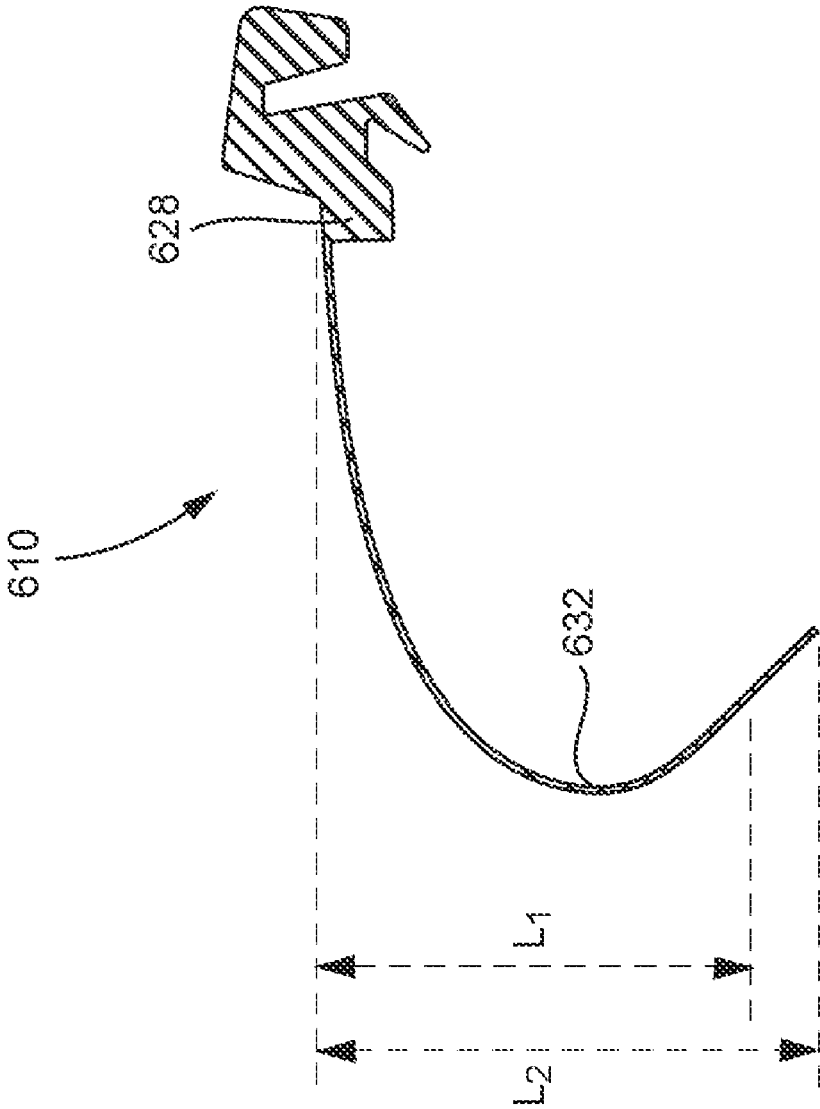

Fig. 76

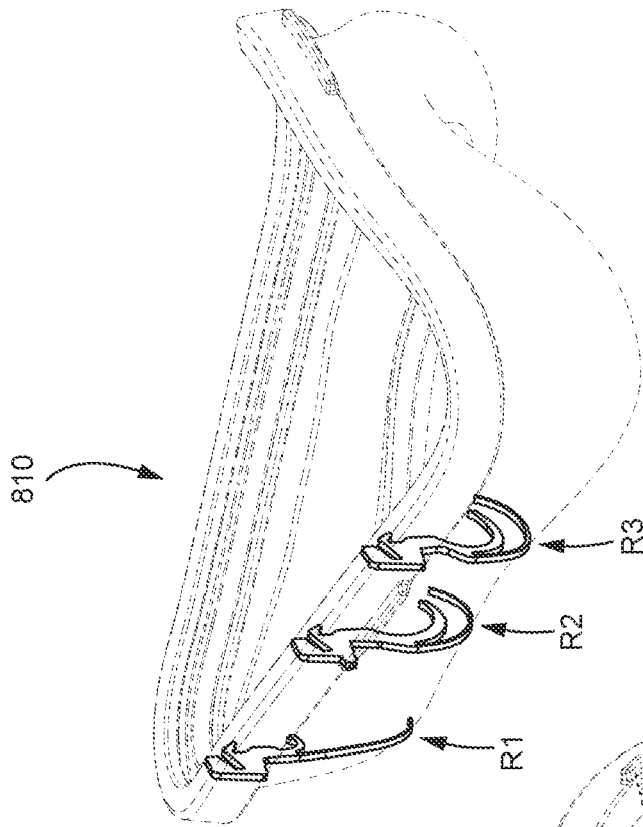

Fig. 78

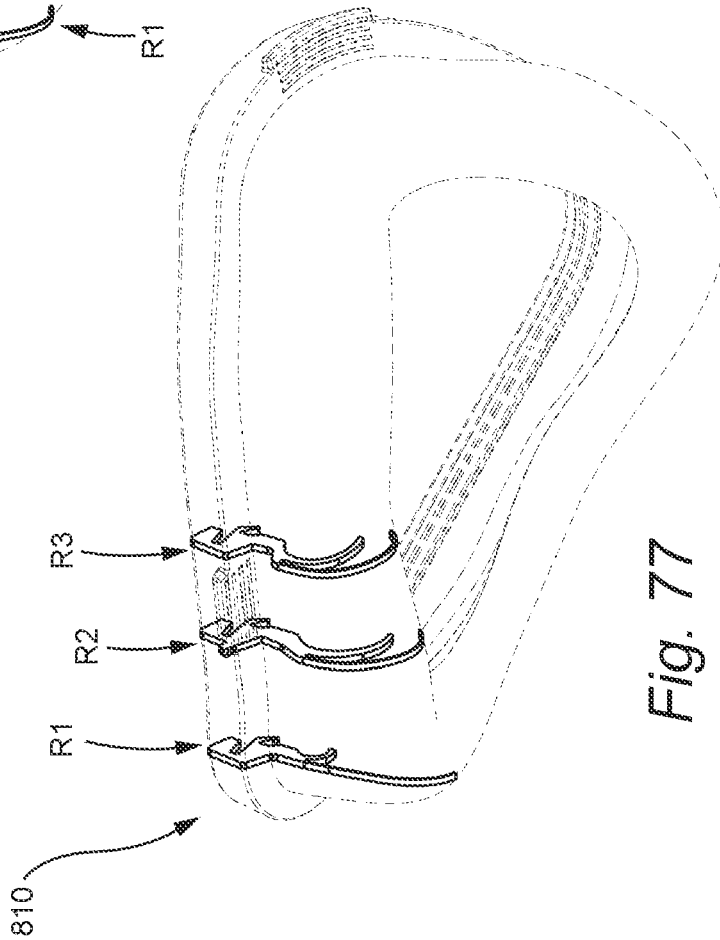

Fig. 77

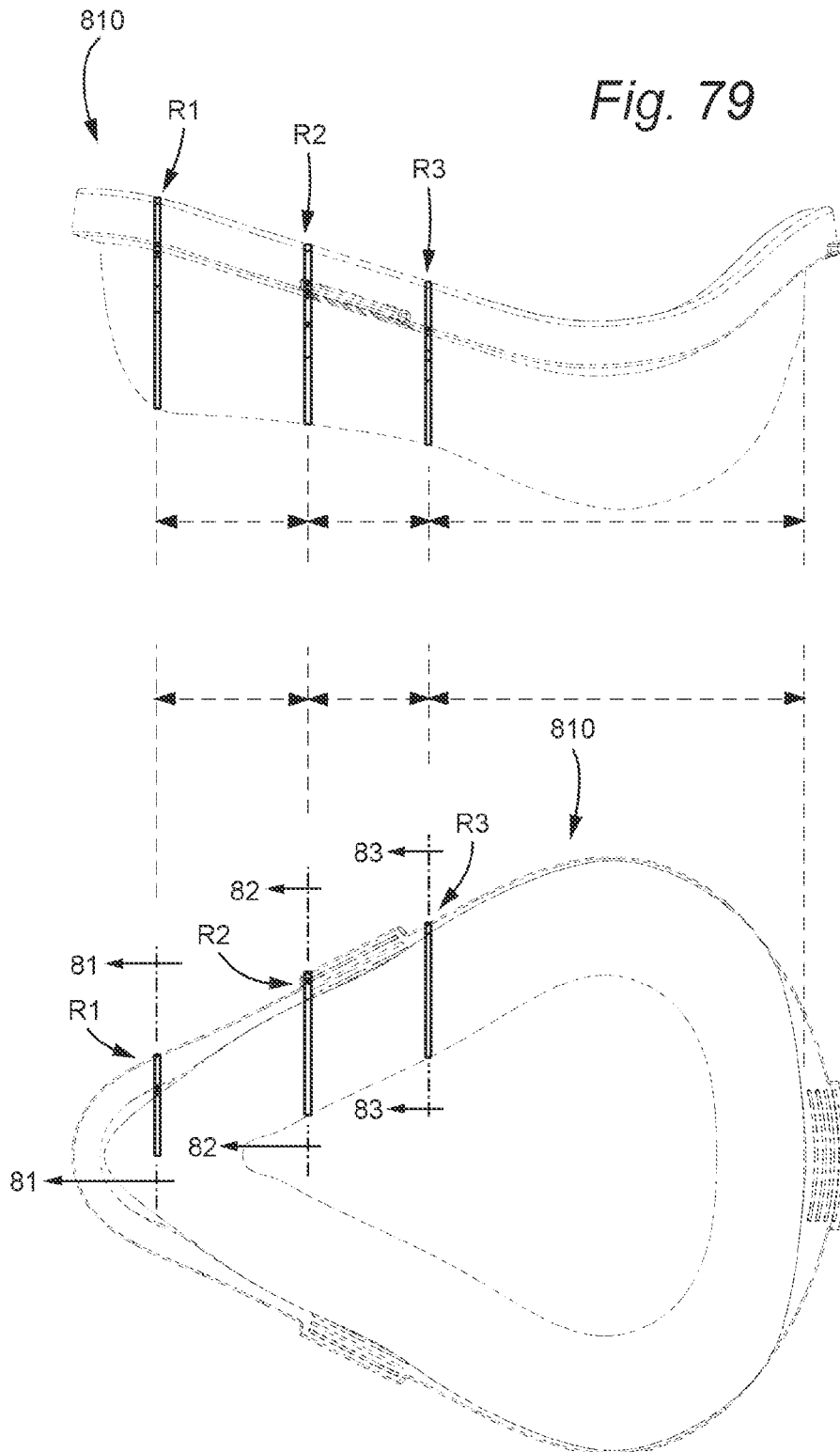

Fig. 79

Fig. 80

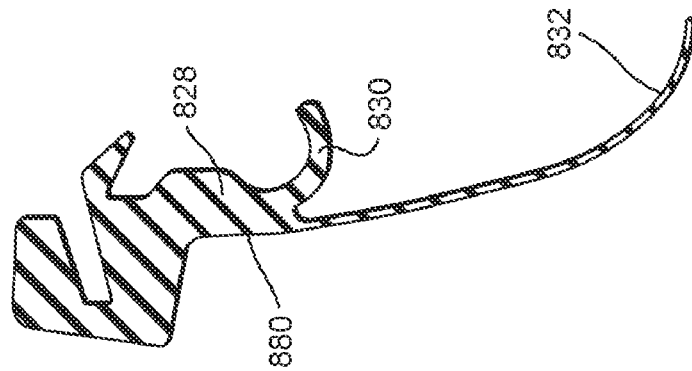

Fig. 81

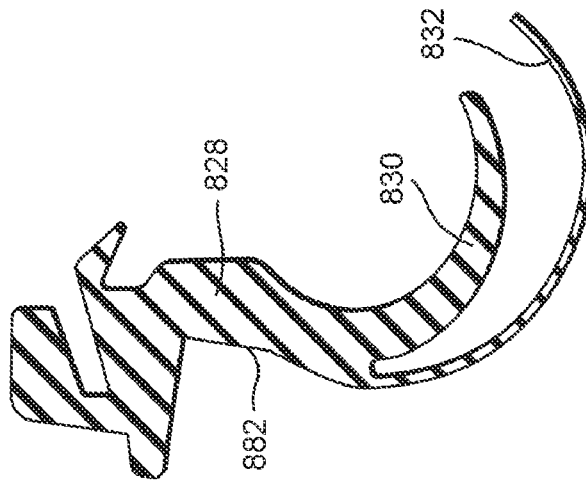

Fig. 82

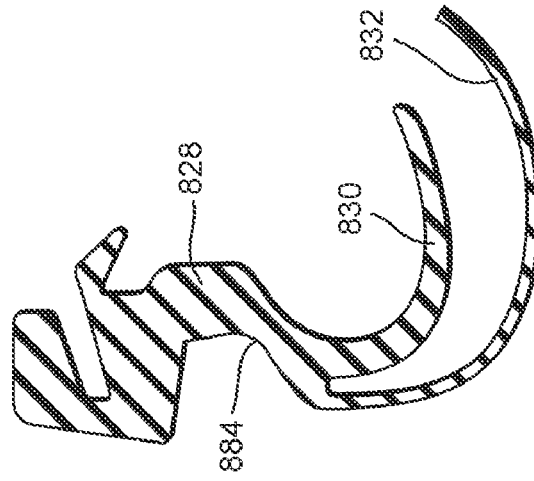

Fig. 83

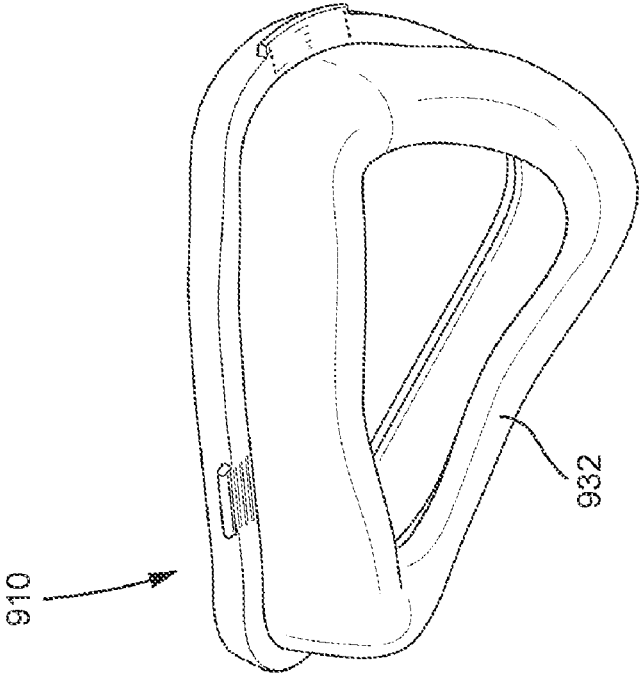

Fig. 85

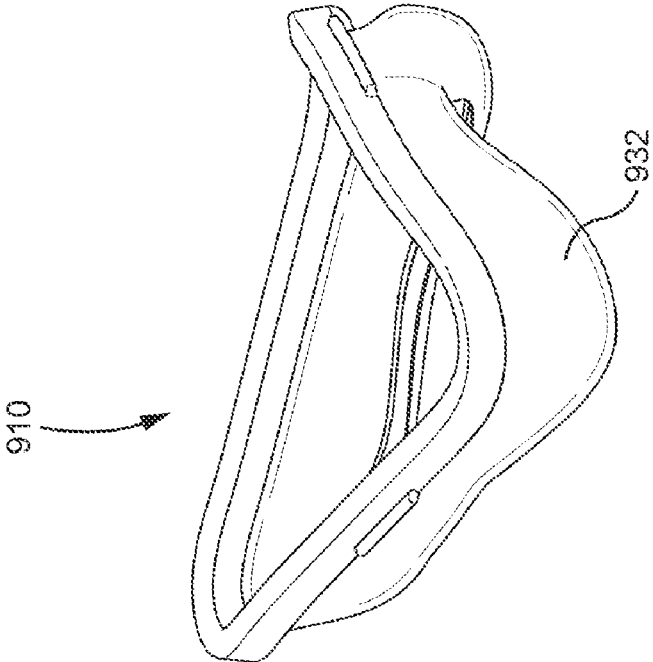

Fig. 84

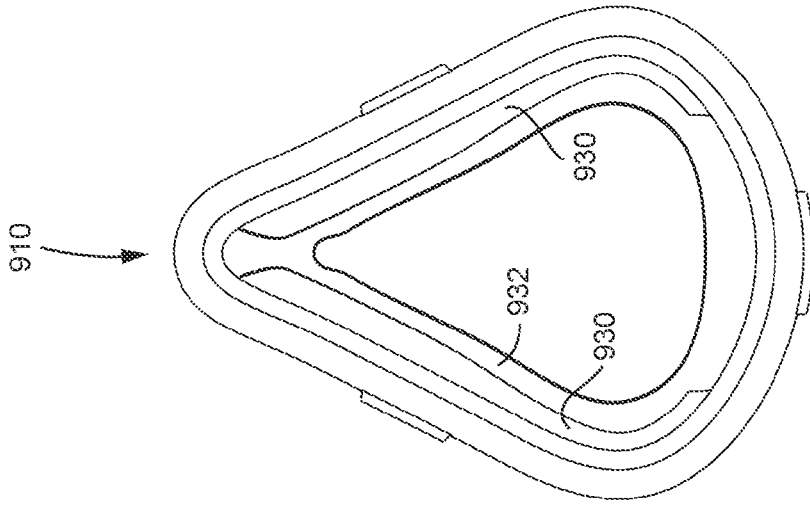

Fig. 88

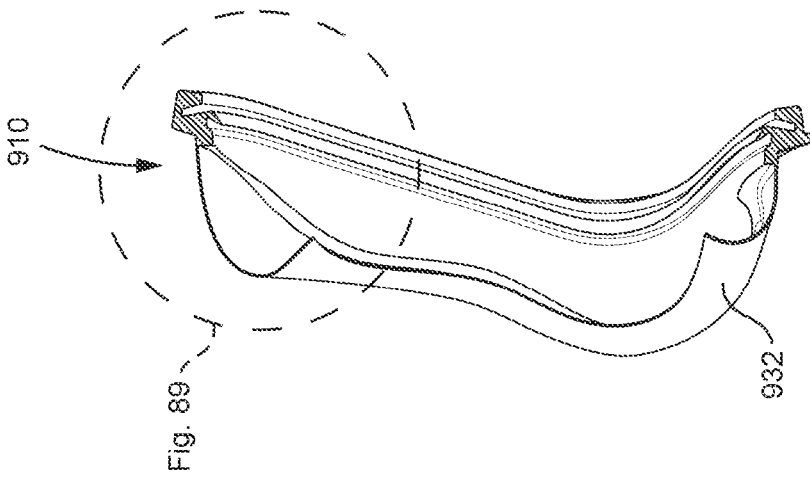

Fig. 87

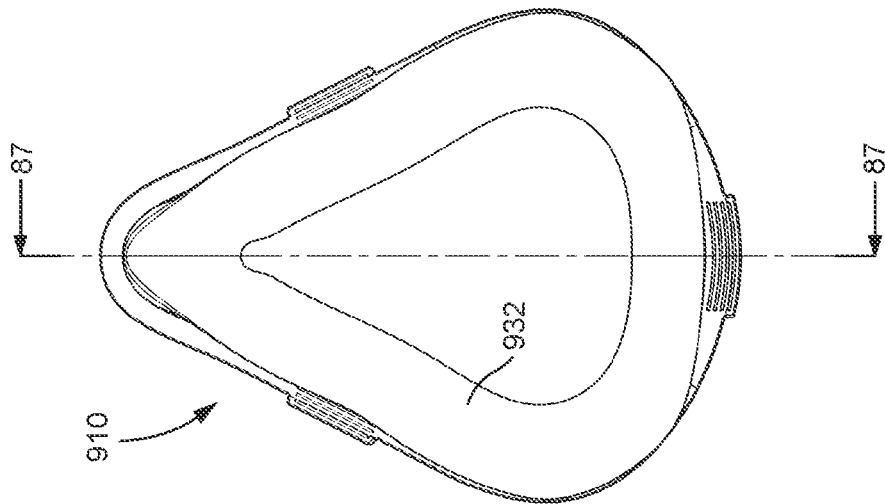

Fig. 86

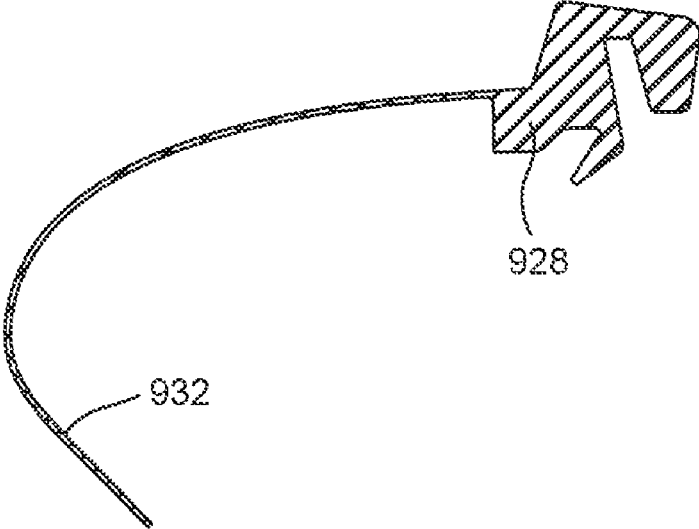

Fig. 89

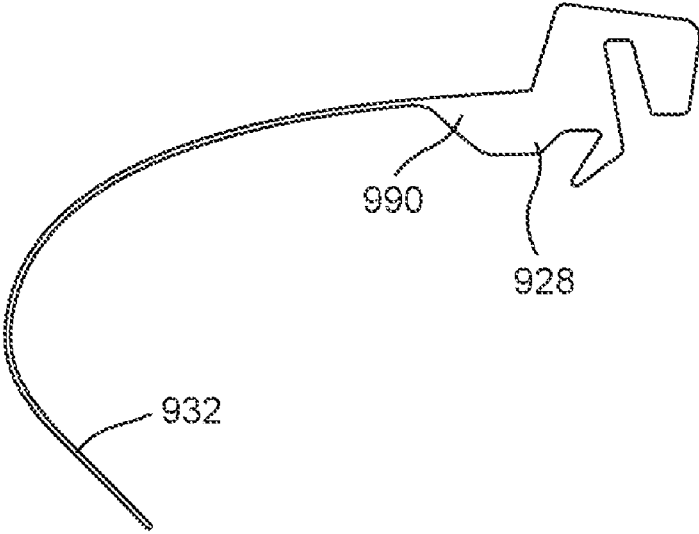

Fig. 90

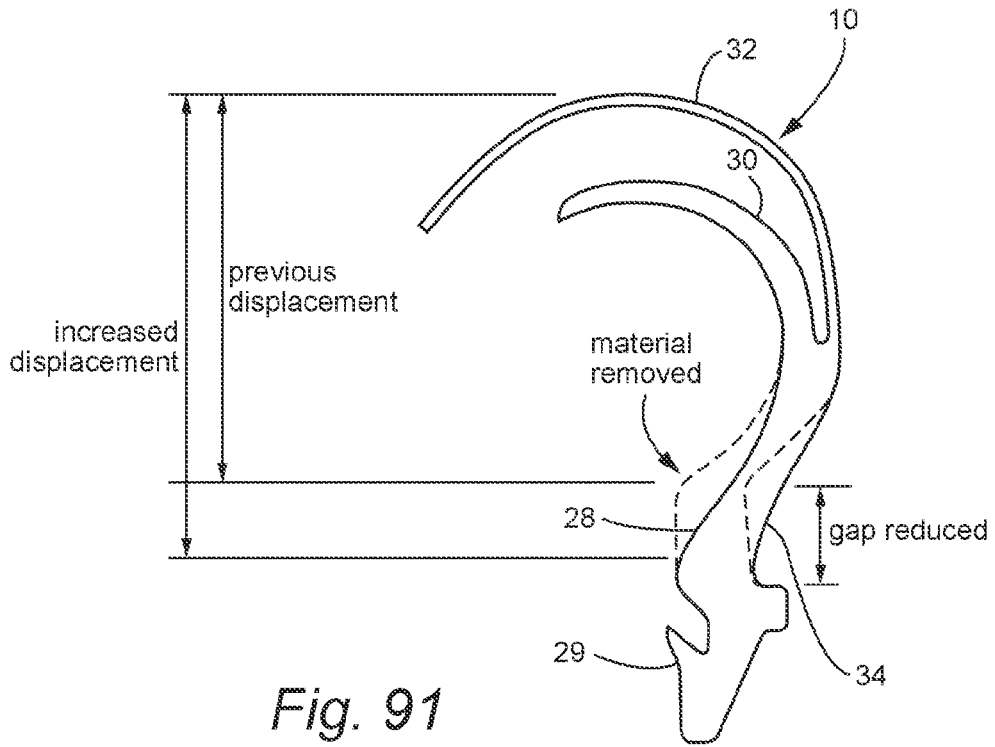

Fig. 91

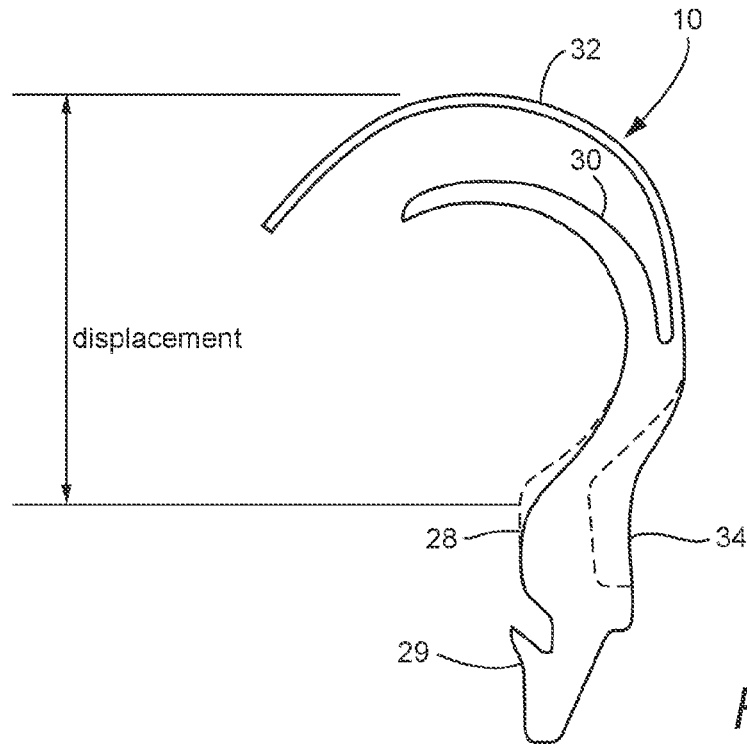

Fig. 92

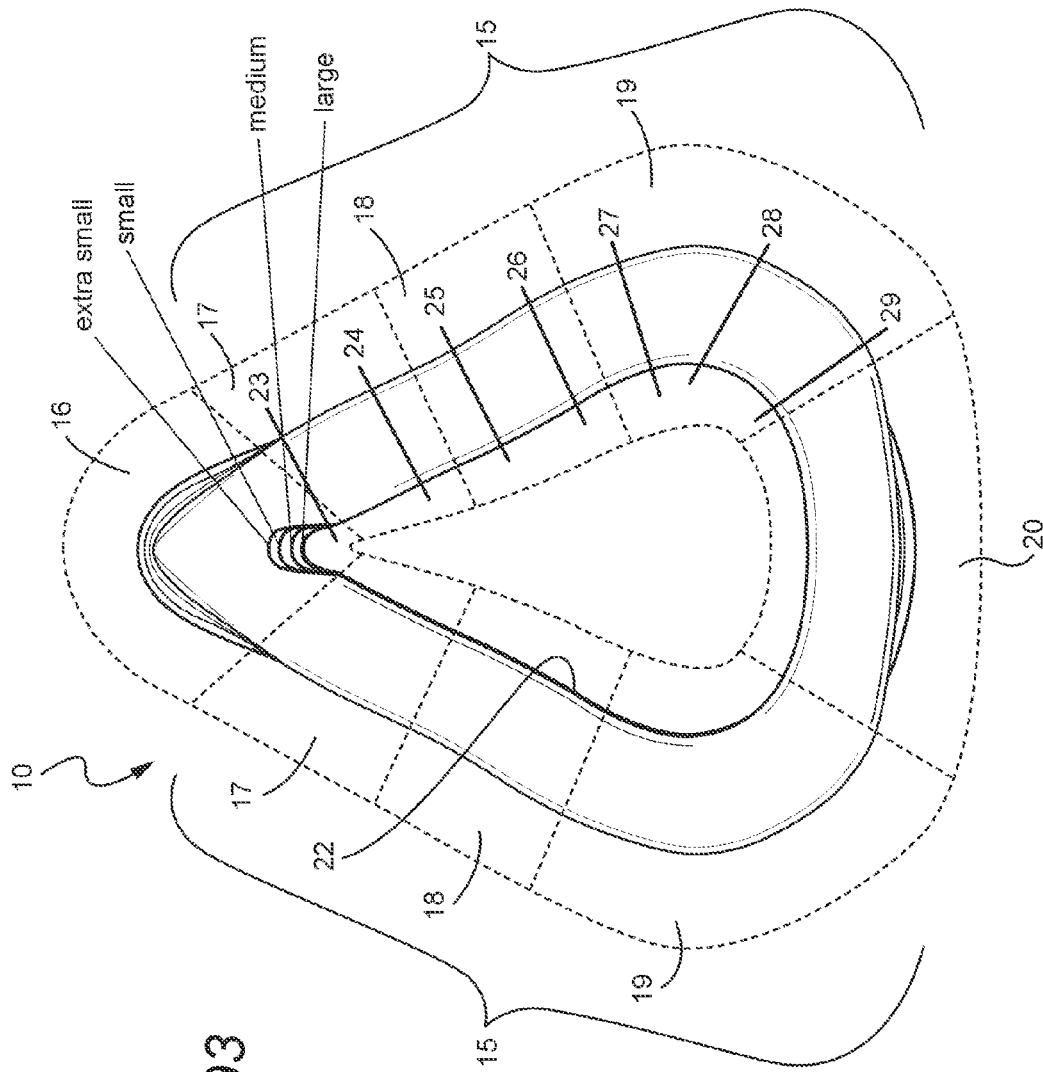

Fig. 93

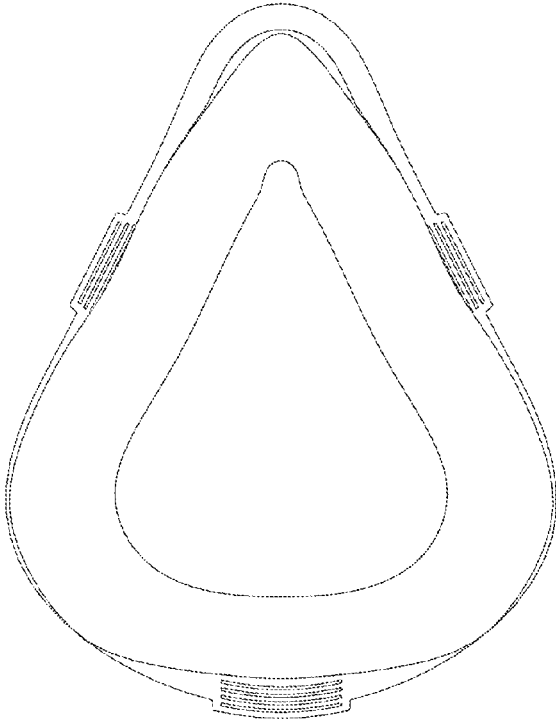

Fig. 94A

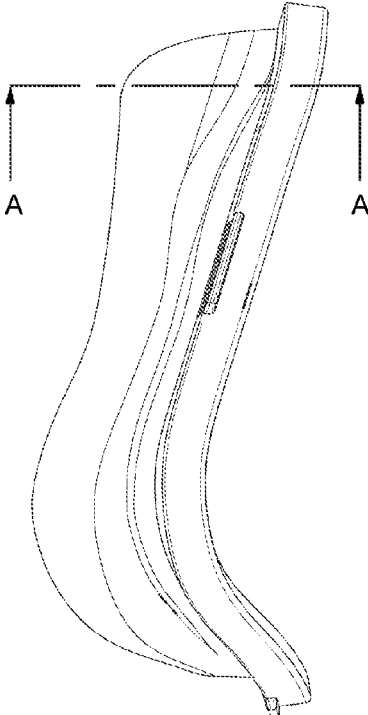

Fig. 94B

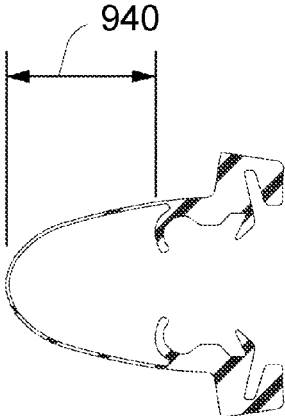

Fig. 94C

SECTION A-A

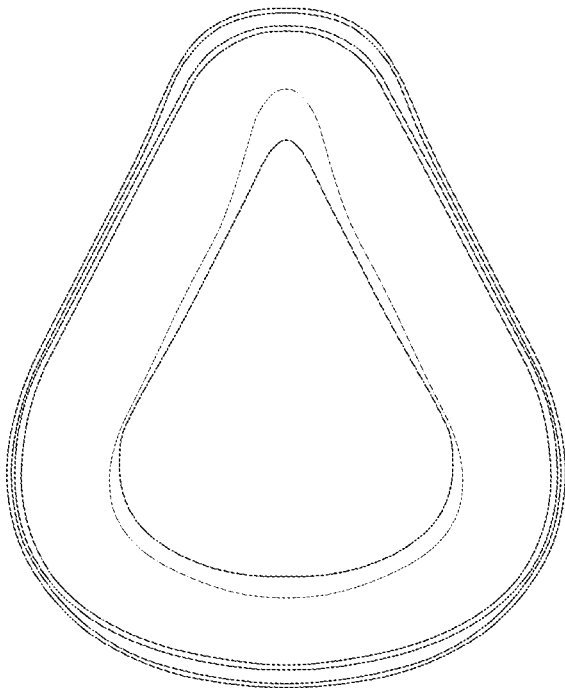

Fig. 95A

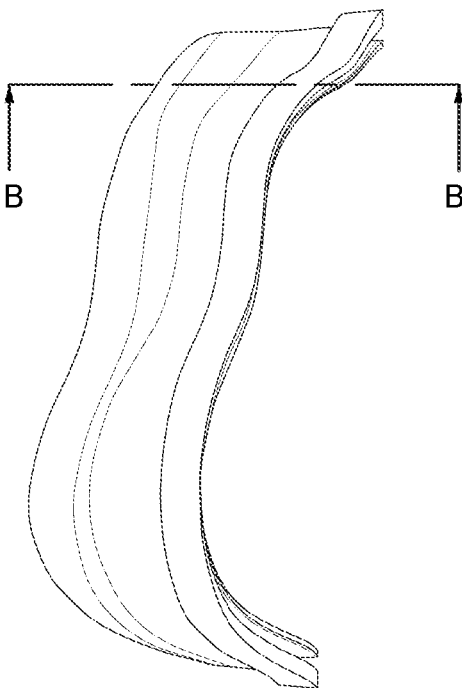

Fig. 95B

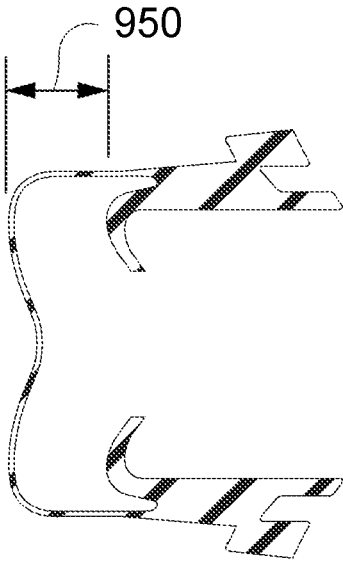

Fig. 95C
SECTION B-B

CUSHION FOR PATIENT INTERFACE

CROSS-REFERENCE TO APPLICATIONS

[0001] This application is a continuation of U.S. Ser. No. 13/537,876, filed Jun. 29, 2012, pending, which is a continuation of U.S. Ser. No. 11/793,981, filed Jun. 25, 2007, now U.S. Pat. No. 8,220,459, which is the U.S. national phase of international application PCT/AU2006/000032, filed Jan. 12, 2006, which designated the U.S. and claims the benefit of U.S. Provisional Application No. 60/643,130, filed Jan. 12, 2005, and 60/724,303, filed Oct. 7, 2005. Each of the applications mentioned above is incorporated herein by reference in its entirety.

FIELD OF THE INVENTION

[0002] The present invention relates to a cushion for a patient interface, the patient interface being used in the treatment, e.g., of Sleep Disordered Breathing (SDB) with Non-Invasive Positive Pressure Ventilation (NPPV).

BACKGROUND OF THE INVENTION

[0003] The use of NPPV for treatment of SDB such as Obstructive Sleep Apnea (OSA) was pioneered by Sullivan (see U.S. Pat. No. 4,944,310). Apparatus for the treatment of SDB involves a blower which delivers a supply of air at positive pressure to a patient interface via a conduit. The patient interface may take several forms, such as a nasal mask assembly and a nasal and mouth mask assembly. Patients typically wear a mask assembly while sleeping to receive the NPPV therapy.

[0004] Mask assemblies typically comprise a rigid shell or frame and a soft face-contacting cushion. The cushion spaces the frame away from the patient's face. The frame and cushion define a cavity which receives the nose or nose and mouth. The frame and cushion are held in position on the patient's face by a headgear assembly. The headgear assembly typically comprises an arrangement of straps which pass along both sides of the patient's face to the back or crown of the patient's head.

[0005] U.S. Pat. No. 5,243,971 (Sullivan and Bruderer) describes a nasal mask assembly for Continuous Positive Airway Pressure (CPAP) having a ballooning/molding seal that conforms with the patient's nose and facial contours. The mask assembly has a face-contacting portion mounted to a shell which is sized and shaped to overfit the nose region of the patient. The face-contacting portion is in the form of a distensible membrane which is molded from an elastic plastic material. The distensible membrane and the shell together define a chamber. Pressurized gas admitted to the chamber causes the membrane to distend outwardly from the patient's face. The contents of this patent are hereby incorporated by reference.

[0006] U.S. Pat. No. 6,112,746 (Kwok et al.) describes a nasal mask assembly and a mask cushion therefore. The contents of this patent are hereby incorporated by reference. The cushion comprises a substantially triangularly-shaped frame from which extends a membrane. The frame has an edge by which the cushion is affixed to a mask body. The membrane has an aperture into which the patient's nose is received. The membrane is spaced away from the rim of the frame, and its outer surface is of substantially the same shape as the rim.

[0007] The cushion of a patient interface can play a key role in the comfort and effectiveness of therapy. There is consid-

erable variation in facial size and shape which can mean that a mask designed for one type of face may not be suitable for another. For example, an Asian-type nose tends to have a lower nasal bridge whereas a Caucasian-type nose has a higher nasal bridge. Using the wrong cushion can lead to excessive leak and discomfort. While creating customized cushions for every patient may solve some fitting issues, customized masks are very expensive. Thus, manufacturers seek to develop cushions which provide a comfortable and effective seal for a range of facial sizes and shapes.

SUMMARY OF THE INVENTION

[0008] One aspect of the invention is to provide a patient interface having a cushion that provides more comfort to the patient while maintaining an effective seal.

[0009] Another aspect of the invention is to provide a comfortable cushion for a patient interface which fits a wide range of facial shapes and sizes.

[0010] Another aspect of the invention relates to a cushion including an underlying cushion and a membrane, wherein the underlying cushion and the membrane have a substantially flat portion in a nasal region of the cushion.

[0011] Another aspect of the invention relates to a cushion including a base wall, an underlying cushion and a membrane, wherein the base wall and underlying cushion have a cross-sectional configuration that provides a variable spring constant around the perimeter of the cushion.

[0012] Another aspect of the invention relates to a patient interface wherein the base wall and the frame connection of the cushion are internally offset with respect to the most external cushion point, e.g., external membrane surface.

[0013] Another aspect of the invention relates to a cushion including a base wall and underlying cushion that are inclined or angled in a side of nose region of the cushion.

[0014] Another aspect of the invention relates to a cushion having a substantially constant mouth width irrespective of its face height.

[0015] Another aspect of the invention relates to a cushion for a patient interface that delivers breathable gas to a patient. The cushion includes a base wall structured to be connected to a frame, an underlying support cushion extending away from the base wall towards the patient's face in use, and a membrane provided to substantially cover at least a portion of the underlying cushion. The membrane includes nasal bridge, cheek, and chin regions adapted to form a continuous seal on nasal bridge, cheek, and chin regions of the patient's face, respectively. The nasal bridge region and adjacent two cheek regions define an intersection or apex. The membrane in the nasal bridge region has a height at the apex or intersection that is greater than a height in an adjacent portion of the cheek region.

[0016] Another aspect of the invention relates to a cushion for a patient interface that delivers breathable gas to a patient. The cushion includes a base wall structured to be connected to a frame, an underlying support cushion extending away from the base wall towards the patient's face in use, and a membrane provided to substantially cover at least a portion of the underlying cushion. The membrane is adapted to form a continuous seal on the patient's face. The underlying cushion has a spring-like connection with the base wall. The underlying cushion and/or base wall define a spring constant that varies along a length of the seal.

[0017] Another aspect of the invention relates to a cushion for a patient interface that delivers breathable gas to a patient.

The cushion includes a base wall structured to be connected to a frame, an underlying support cushion extending away from the base wall towards the patient's face in use, and a membrane provided to substantially cover at least a portion of the underlying cushion. The membrane is adapted to form a continuous seal on the patient's face. One of the membrane and the underlying cushion includes an external surface that defines an outer width of the cushion, and the base wall is internally offset with respect to the external surface.

[0018] Yet another aspect of the invention relates to a cushion for a patient interface that delivers breathable gas to a patient. The cushion includes a base wall structured to be connected to a frame, an underlying support cushion extending away from the base wall towards the patient's face in use, and a membrane provided to substantially cover at least a portion of the underlying cushion. The membrane includes at least nasal bridge and side of nose regions adapted to form a continuous seal on nasal bridge and side of nose regions of the patient's face, respectively. The base wall and the underlying cushion in the side of nose region are inclined or angled with respect to a bottom of the frame.

[0019] Yet another aspect of the invention relates to a cushion for a patient interface that delivers breathable gas to a patient. The cushion includes a base wall structured to be connected to a frame, an underlying support cushion extending away from the base wall towards the patient's face in use, and a membrane provided to substantially cover at least a portion of the underlying cushion. The membrane includes nasal bridge, side of nose, upper cheek, lower cheek and chin regions adapted to form a continuous seal on nasal bridge, side of nose, upper cheek, lower cheek, and chin regions of the patient's face, respectively. An inner edge of the membrane defines an aperture that receives the patient's nose and mouth. A lower portion of the aperture that receives the patient's mouth has a mouth width that remains substantially constant irrespective of a face height of the cushion.

[0020] Yet another aspect of the invention relates to a cushion for a patient interface that delivers breathable gas to a patient. The cushion includes a base wall structured to be connected to a frame, an underlying support cushion extending away from the base wall towards the patient's face in use, and a membrane provided to substantially cover at least a portion of the underlying cushion. The membrane is adapted to form a continuous seal on the patient's face. At least a portion of the underlying cushion and/or base wall has a lower portion including a spring configuration that defines displacement of the cushion with respect to a force applied from the frame.

[0021] Still another aspect of the invention relates to a method of designing a series of mask assemblies. The method includes providing a first cushion adapted to fit a larger range of patients and providing a second cushion adapted to fit a smaller range of patients. Each of the first and second cushions includes an aperture that receives at least the patient's mouth. The aperture of the first and second cushions have the same width.

[0022] Still another aspect of the invention relates to a cushion for a patient interface that delivers breathable gas to a patient. The cushion includes a base wall structured to be connected to a frame, an underlying support cushion extending away from the base wall towards the patient's face in use, and a membrane provided to substantially cover at least a portion of the underlying cushion. The membrane includes at least a nasal bridge region adapted to form a continuous seal

on a nasal bridge region of the patient's face. The membrane forms an elongated ridge in the nasal bridge region. The elongated ridge has sloping sides that meet to form an elongated crest. Each of the sloping sides is angled from a crest centerline in the range of 30-60° and the crest has a radius of curvature in the range of 1.0-5.0 mm.

[0023] Still another aspect of the invention relates to a cushion for a patient interface that delivers breathable gas to a patient. The cushion includes a base wall structured to be connected to a frame, an underlying support cushion extending away from the base wall towards the patient's face in use, and a membrane provided to substantially cover at least a portion of the underlying cushion. The membrane includes at least a nasal bridge region adapted to form a continuous seal on a nasal bridge region of the patient's face. The nasal bridge region of the membrane includes a contoured portion that curves inwardly towards a cavity of the cushion along a radius to terminate at an inner edge of the membrane. The contoured portion has a free end that is angled with respect to a face contacting plane of the cushion in the range of 30-50°.

[0024] Still another aspect of the invention relates to a cushion for a patient interface that delivers breathable gas to a patient. The cushion includes a base wall structured to be connected to a frame, an underlying support cushion extending away from the base wall towards the patient's face in use, and a membrane provided to substantially cover at least a portion of the underlying cushion. The membrane is adapted to form a continuous seal on the patient's face. The underlying cushion and/or base wall has a question-mark or sickle shape.

[0025] Still another aspect of the invention relates to a cushion for a patient interface that delivers breathable gas to a patient. The cushion includes a base wall structured to be connected to a frame, an underlying support cushion extending away from the base wall towards the patient's face in use, and a membrane provided to substantially cover at least a portion of the underlying cushion. The membrane is adapted to form a continuous seal on the patient's face. The underlying cushion has an arcuate configuration including an arc length greater than 16 mm.

[0026] Still another aspect of the invention relates to a cushion for a patient interface that delivers breathable gas to a patient. The cushion includes a base wall structured to be connected to a frame, an underlying support cushion extending away from the base wall towards the patient's face in use, and a membrane provided to substantially cover at least a portion of the underlying cushion. The membrane is adapted to form a continuous seal on the patient's face. The membrane includes a thickness that varies along a length of the seal.

[0027] Still another aspect of the invention relates to a cushion for a patient interface that delivers breathable gas to a patient. The cushion includes a base wall structured to be connected to a frame and a membrane adapted to form a continuous seal on the patient's face. At least a portion of the base wall includes a tapered portion that tapers towards the membrane.

[0028] Still another aspect of the invention relates to a mask system including a set of at least two cushions arranged to suit different face sizes, wherein the at least two cushions have substantially the same width.

[0029] Other aspects, features, and advantages of this invention will become apparent from the following detailed description when taken in conjunction with the accompany-

ing drawings, which are a part of this disclosure and which illustrate, by way of example, principles of this invention.

BRIEF DESCRIPTION OF THE DRAWINGS

[0030] The accompanying drawings facilitate an understanding of the various embodiments of this invention. In such drawings:

[0031] FIGS. 1-9 illustrate a cushion for a patient interface constructed according to an embodiment of the present invention and showing exemplary dimensions of an embodiment;

[0032] FIGS. 10-14 are cross-sectional views through the cushion shown in FIG. 5;

[0033] FIG. 15 is a front view of the cushion shown in FIGS. 1-9 that illustrates various regions of the cushion;

[0034] FIGS. 16-17 illustrates another size of the cushion shown in FIGS. 1-9;

[0035] FIGS. 18-19 illustrates yet another size of the cushion shown in FIGS. 1-9;

[0036] FIGS. 20-21 illustrates still another size of the cushion shown in FIGS. 1-9;

[0037] FIG. 22 is a cross-sectional view through the cushion shown in FIGS. 1-9 that illustrates parameters that can modify a spring characteristic of the underlying cushion;

[0038] FIGS. 23-29 are cross-sectional views through the cushion shown in FIG. 15 and showing exemplary parameters of an embodiment, the cross-sectional views illustrating the underlying cushion only;

[0039] FIGS. 30A-30N are cross-sectional views illustrating alternative embodiments of a cushion according to the present invention;

[0040] FIG. 31-32 are graphs illustrating the general relationship between Force and Displacement for embodiments of the cushion shown in FIGS. 1-9 and a known cushion commercially sold under the name of UltraMirage® Full Face by ResMed Ltd.;

[0041] FIG. 33 is a graph illustrating the general relationship between Force and Displacement for various cross-sections of the cushion shown in FIGS. 23-29;

[0042] FIG. 34A illustrates a spring length for the cushion shown in FIGS. 1-9, and showing exemplary dimensions of an embodiment according to the present invention;

[0043] FIG. 34B illustrates a spring length for a known cushion commercially sold under the name of UltraMirage® Full Face by ResMed Ltd., and showing exemplary dimensions of the UltraMirage® Full Face;

[0044] FIG. 35 is a side view of the cushion shown in FIGS. 1-9;

[0045] FIGS. 36-37 are cross-sectional views through the cushion shown in FIG. 35;

[0046] FIG. 38 is a front view of the cushion shown in FIGS. 1-9 illustrating a flat portion thereof;

[0047] FIG. 38B is a graph illustrating the general relationship between Force and Displacement in a nasal bridge region for embodiments of the cushion shown in FIGS. 1-9 and a known cushion commercially sold under the name of UltraMirage® Full Face mask by ResMed Ltd.;

[0048] FIGS. 39-40B are front and cross-sectional views of an embodiment of the cushion shown in FIGS. 1-9, and showing exemplary dimensions of an embodiment according to the present invention;

[0049] FIGS. 41-45 are perspective views of an embodiment of the cushion shown in FIGS. 1-9 illustrating the rolling action of the nasal bridge region in use;

[0050] FIGS. 46-53 illustrate a known cushion commercially sold under the name of UltraMirage® Full Face by ResMed Ltd.;

[0051] FIGS. 54-58 illustrate a cushion for a patient interface according to another embodiment of the present invention and showing exemplary dimensions of an embodiment;

[0052] FIGS. 59-63 are cross-sectional views through the cushion shown in FIG. 54;

[0053] FIG. 64 is a cross-sectional view of a portion of the cushion shown in FIGS. 54-58 (in solid lines) overlaid with a cross-section of a known cushion commercially sold under the name of UltraMirage® Full Face by ResMed Ltd. (only relevant portions of the UltraMirage® cushion may be shown in dashed lines, i.e., there may be other different portions not shown);

[0054] FIG. 65 is a cross-sectional view of a portion of the cushion shown in FIGS. 54-58 showing exemplary dimensions of an embodiment according to the present invention;

[0055] FIGS. 66-69 are cross-sectional views through the cushion shown in FIG. 54, and showing exemplary dimensions of an embodiment according to the present invention;

[0056] FIGS. 70-71 are plan and cross-sectional views, respectively, of the cushion shown in FIG. 54, and showing exemplary dimensions of an embodiment according to the present invention;

[0057] FIGS. 72-76 illustrate a cushion for a patient interface according to another embodiment of the present invention;

[0058] FIGS. 77-83 illustrate a cushion for a patient interface according to another embodiment of the present invention;

[0059] FIGS. 84-90 illustrate a cushion for a patient interface according to another embodiment of the present invention;

[0060] FIG. 91 illustrates an alternative cushion cross-section to that shown in FIG. 34A;

[0061] FIG. 92 illustrates another alternative cushion cross-section to that shown in FIG. 34A;

[0062] FIG. 93 illustrates an alternative cushion arrangement to that shown in FIG. 15;

[0063] FIGS. 94A-94C are a set of views depicting a horizontal cross-section through the nasal bridge region of the cushion of FIG. 35; and

[0064] FIGS. 95A-95C are a set of views depicting a horizontal cross-section through the nasal bridge region of the prior art cushion of FIG. 51.

DETAILED DESCRIPTION OF ILLUSTRATED EMBODIMENTS

[0065] FIGS. 1-14 illustrate a cushion 10 constructed according to an embodiment of the present invention. The cushion 10 is adapted to be removably or permanently connected (e.g., via mechanical and/or adhesive fastening) to a frame of a patient interface structured to deliver breathable gas to a patient. In an embodiment, the cushion 10 may be co-molded to a frame of a patient interface. In another embodiment, the cushion may form part of a frame with an outer support structure, e.g., ResMed's Hospital Nasal Mask. The cushion 10 provides a seal with the patient's face during use.

[0066] In the illustrated embodiment, the cushion 10 forms a part of a full-face mask. Specifically, the cushion 10 provides a seal around the patient's nose and mouth to enable the delivery of breathable gas to the patient's nose and mouth.

However, aspects of the present invention may be applicable to other breathing arrangements, e.g., a nasal mask, a mouth mask, etc. The cushion **10** may be used with a gusset as described in U.S. patent application Ser. No. 10/655,622, incorporated herein by reference in its entirety.

[0067] The cushion **10** is structured to provide a more comfortable fit for a wide range of facial shapes and sizes. Also, the cushion **10** is structured to provide a better seal and reduce the risk of leakage as discussed below.

[0068] As illustrated in FIGS. **1-14**, the cushion **10** includes a non-face-contacting portion **12** structured to be connected to a frame of the patient interface, e.g., via a friction-fit, a tongue-and-groove arrangement, etc., and a face-contacting portion **14** structured to engage the patient's face.

[0069] As best shown in FIGS. **5** and **15**, the face-contacting portion **14** of the cushion **10** preferably has a generally triangular shape and is structured to continuously contact nasal bridge, side of nose, upper cheek, lower cheek, and chin regions of the patient. However, the face-contacting portion **14** may have other suitable shapes, e.g., a generally trapezoidal shape. In the illustrated embodiment, as best shown in FIG. **15**, the cushion **10** includes a nasal bridge region **16** to provide a seal along the patient's nasal bridge, a pair of cheek regions **15** to provide a seal along the patient's nose, cheek, and mouth, and a chin region **20** to provide a seal along the patient's chin. The pair of cheek regions **15** may be further defined as a pair of side of nose regions **17** to provide a seal along the sides of the patient's nose, a pair of upper cheek regions **18** to provide a seal along upper cheeks of the patient, and a pair of lower cheek regions **19** to provide a seal along the patient's lower cheeks and the sides of the patient's mouth.

[0070] Width of Cushion in Lower Cheek Regions and Ratio of Face Width to Height Across Mask Sizes

[0071] The cushion **10** may be provided in various sizes in order to accommodate various facial sizes. For example, FIGS. **16-21** illustrate embodiments of the cushion **10** in three other sizes. In an embodiment, the cushion **210** shown in FIGS. **16-17** may represent a extra small size, the cushion **310** shown in FIGS. **18-19** may represent a small size, the cushion **10** shown in FIGS. **1-14** may represent a medium size, and the cushion **410** shown in FIGS. **20-21** may represent a large size. As illustrated, the mouth width of the cushions **10**, **210**, **310**, **410** are substantially constant irrespective of their face height.

[0072] Specifically, the cushion **10** defines an aperture **22** that receives the patient's mouth. In a preferred embodiment, the lower portion of the aperture **22** has a constant width for all cushion sizes, e.g., 60 mm. However, the width of the lower portion of the aperture **22** may be almost constant, e.g., in a range of 5 mm, for all cushion sizes. For example, the width of the lower portion of the aperture **22** of the cushion **10** may be 60 mm \pm 5. In contrast, the width of the lower portion of the aperture **722** of a known cushion **700** commercially sold under the name of UltraMirage® Full Face by ResMed Ltd. is 60 mm for a large size, 54 mm for a medium size, and 52 mm for a small size. The UltraMirage® cushion **700** is shown in FIGS. **46-53**.

[0073] Anthropometric data has indicated that mouth widths for patients with relatively small faces are not necessarily narrower than mouth widths for patients with relatively large faces. Hence, all faces generally have the same mouth width. Thus, the aperture **22** in the cushion **10** is made sufficiently wide to accommodate a wide range of patients and remains constant or almost constant, e.g., a range of 5 mm, regardless of the change in face height of a mask to fit larger

faces. This can be seen in the substantially constant cushion geometry around the lower cheek and chin regions of the different cushion sizes, and thus the varying width to height ratios of the different cushion sizes. For example, the lower portion of the aperture **22** of each of the cushions **10**, **210**, **310**, **410** has substantially the same width.

[0074] Base Wall, Underlying Cushions, and Membrane

[0075] As best shown in FIGS. **9** and **10-14**, the face-contacting portion **14** of the cushion **10** includes a base wall **28**, a pair of underlying support cushions **30** extending away from the base wall **28**, and a membrane **32** provided to substantially cover at least a portion of the underlying cushions **30** and provide a sealing structure for the face contacting portion **14**. The base wall **28** and underlying cushions **30** provide a support structure for the membrane **32**.

[0076] As illustrated, the underlying cushions **30** are preferably provided on lateral sides of the base wall **28** only, e.g., in the side of nose, upper cheek, and lower cheek regions **17**, **18**, **19**, although the underlying cushions **30** could be joined and substantially surround the patient's nose and also the lower lip or chin region. The underlying cushions **30** add rigidity to the membrane **32** at the sides of the patient's mouth and cheeks. While it is preferable that the membrane **32** be thinner than the underlying cushions **30**, they could have the same thickness or the membrane could be thicker than the underlying cushion. Also, the elimination of an underlying cushion in the chin region **20** allows the cushion **10** to more deeply engage with the patient's face in this region without subjecting the patient's chin region **20** to excessive pressure. That is, there is no underlying cushion to restrain the movement of the membrane **32** in this region, which may improve the seal in this region and adjacent regions. Additionally, the elimination of an underlying cushion in the chin region **20** enables the cushion **10** to accommodate more facial shapes and provides more flexibility and allows for movement or opening of the mouth.

[0077] In the illustrated embodiment, the face-contacting portion **14** of the cushion has a double-walled construction, i.e., membrane **32** and underlying cushion **30**, in the side of nose, upper cheek, and lower cheek regions **17**, **18**, **19**, and a single-walled construction, i.e., membrane **32**, in the nasal bridge and chin regions **16**, **20** as shown in FIGS. **10-14**. The single wall construction at the top and bottom of the cushion **10** helps to accommodate high landmarks, e.g., pointed chin, by allowing the center of the cushion **10** to flex. This flexibility accommodates more patients with the same cushion. However, the cushion **10** may have any other suitable construction, e.g., single walled, double walled, triple walled or more walled construction, in any suitable region of the cushion **10**, e.g., cheek, chin, nasal bridge. For example, the underlying cushion **30** may extend around the entire perimeter of the cushion **10**. Also, the underlying cushion **30** could be completely removed.

[0078] As shown in FIGS. **10-14**, the membrane thickness may vary in the different regions of the cushion **10**. As illustrated, the membrane in the nasal bridge region **16** and upper cheek region **18** is 0.3 mm thick which transitions to 0.5 mm thickness in the upper cheek region **18** and maintains this thickness in the lower cheek and chin regions **19**, **20**. This arrangement provides greater compliance/stretch across the nasal bridge by providing a thinner membrane. This stretch is not required at the lower regions and here the thicker membrane is less likely to vibrate on the patient face in use.

Internally Offset Base Wall and Frame Connection

[0079] Another aspect of the invention relates to the size and configuration of the base wall **28**, underlying cushion **30**, and membrane **32** of the cushion **10**. FIGS. **48-50** illustrate the base wall **728**, underlying cushion **730**, and membrane **732** of the UltraMirage® cushion **700**. As illustrated, the cushion **10** has a different cross-sectional profile than the UltraMirage® cushion **700**.

[0080] For example, as best shown in FIGS. **11-13**, the base wall **28** and the frame connection **29** are internally offset with respect to the most external cushion point **39**, e.g., external surface of membrane or underlying cushion. In contrast, the base wall **728** and frame connection **729** of the UltraMirage® cushion **700** are not offset with respect to the most external cushion point **739** (see FIGS. **48-50**). As a result of this inward movement, the base width of the cushion **10** is narrowed, e.g., by about 5 mm or 2.5 mm per base, which provides a less obtrusive cushion and saves material which means less weight and cost. Also, the narrower cushion **10** provides less free length for the cushion **10** to bulge outwardly in use, thus helping to minimize or eliminate leakage.

[0081] As illustrated, a lower portion of the underlying cushion **30** has a more arcuate, e.g., semi-circular, question-mark, sickle-shape, configuration that defines a space **34** below a lower portion of the underlying cushion **30** and adjacent the base wall **28**.

[0082] In the illustrated embodiment, the widest or most external cushion point is the external surface of the underlying cushion **30** and the base wall **28** and frame attachment **29** are offset internally with respect to this. Thus, by the design of the cushion **10** and in particular the underlying cushion curvature, the frame is attached at a narrower point and thus the frame itself is narrower. This arrangement has significant advantages in terms of the frame weight, perceived bulk, and size. This arrangement may also minimize the dead space within the mask which will help to reduce CO₂ rebreathing.

[0083] Moreover, the space **34** below the underlying cushion **30** allows a greater range of movement of the underlying cushion **30** to add more flexibility to the underlying cushion **30** and hence the membrane **32** in use. Specifically, the space **34** below the underlying cushion **30** enables more displacement of the underlying cushion **30** using substantially the same space restraints as the UltraMirage® cushion **700**, for example. Additionally, the space **34** allows more displacement of the underlying cushion **30** before bottoming out, therefore reducing discomfort. Thus, this arrangement provides a more gradual force, improves comfort, and allows a wider range of patients to achieve seal.

Variable Spring Constant

[0084] As illustrated, the underlying cushion **30** has a spring-like connection with the base wall **28** such that the underlying cushion **30** can move with respect to the base wall **28**. That is, the underlying cushion **30** is movable into the space **34** (the underlying cushion **30** is also movable into the space **33**). Thus, a spring force is provided when a frame force is applied and the underlying cushion **30** is resiliently moved back into its initial position when the frame force is released. The underlying cushion **30** and/or base wall **28** may have any suitable spring constant, and the spring constant may be varied anywhere along its length, e.g., by tapering and/or varying the thickness of the base wall **28**, varying the thickness of intermediate and/or lower portions of the underlying cushion

30. Also, the spring-like connection may extend along the whole underlying cushion **30** or the spring-like connection may be localized in certain regions such as the cheekbone region.

[0085] Thus, a spring characteristic is molded with the base wall **28** and underlying cushion **30** of the cushion **10** which allows a continuously variable spring constant to be incorporated into the base wall **28** and underlying cushion **30**, e.g., the wall stiffness can be varied at each cushion region to suit the sealing requirements in each region which may vary due to the underlying facial structure of the patient.

[0086] The spring characteristics of the base wall **28** and underlying cushion **30** may be modified by varying a number of characteristics shown in FIG. **22**. For example, the spring characteristics may be modified by varying the underlying cushion height *h*, the thickness *t*, the radius *r*, and the underlying cushion offset *c*. It is to be understood that these parameters are merely exemplary, and other parameters may be varied to modify the spring characteristics of the base wall **28** and underlying cushion **30**.

[0087] FIGS. **23-29** illustrate parameters of an embodiment of the underlying cushion **30** and base wall **28** to achieve desired spring characteristics. As illustrated, the underlying cushion **30** and base wall **28** is configured to provide a variable spring constant around the perimeter of the cushion **10**. That is, the spring constant of the underlying cushion **30** and base wall **28** differs along the side of nose, upper cheek, and lower cheek regions **17, 18, 19**. Although specific parameters of the cushion **10** are shown in FIGS. **23-29**, it is to be understood that these parameters are merely exemplary and other parameters are possible depending on application.

[0088] In the nasal bridge region **16** (e.g., see FIG. **10**), no underlying cushion **30** is provided in order to provide high flexibility and the ability to conform to a variety of facial shapes. However, in an embodiment, there may be an underlying cushion **30** with a very soft spring characteristic in this region.

[0089] In the side of nose regions **17** (see FIGS. **23-24**), an underlying cushion **30** and base wall **28** with a fairly stiff spring characteristic is provided in order to provide lateral stability to squeeze the side of the patient's nose and keep the membrane **32** in contact with the underlying cushion **30**. As illustrated, this arrangement is achieved by a relatively thick underlying cushion, short height, and tight radius. In an embodiment of the section shown in FIG. **23**, *h* may be 12 mm, *r* may be 5 mm, *t* may be 2-3 mm, *b* may be 4 mm, *w*₁ may be 11.5 mm, and *w*₂ may be 8 mm. In an embodiment of the section shown in FIG. **24**, *h* may be 14 mm, *r* may be 6-7 mm, *t* may be 2.5 mm, *b* may be 4 mm, *w*₁ may be 11.5 mm, *w*₂ may be 9.5 mm, and *a* may be 22°. It is to be understood that these dimensions and ranges are merely exemplary and other dimensions and ranges are possible depending on application.

[0090] Also, as best shown in FIG. **24**, the base wall **28** and underlying cushion **30** in the side of nose regions **17** have been rotated by about 22 degrees with respect to the bottom of the frame. That is, the base wall **28** and underlying cushion **30** are inclined or angled in the side of nose regions **17** of the cushion **10**. This arrangement further increases the lateral stability and allows the force on the membrane to be applied perpendicular to the skin surface at the side of the patient's nose. This further helps to keep the membrane **32** in contact with the patient's skin and prevent any air leaks. In further embodiments, this angle may vary from 15 to 30 degrees.

[0091] In the upper cheek regions 18 (see FIGS. 25-26), the underlying cushion 30 and base wall 28 have a stiffness that is less than that provided in the side of nose regions 17 but stiffer than that provided in the lower cheek regions 19 due to the geometry of the underlying cushion, this is provided to suit the firmer bone structure of the upper cheeks. In an embodiment of the section shown in FIG. 25, h may be 12-15 mm, preferably 13.5 mm, r may be 5 mm, t may be 2 mm, b may be 3 mm, and w1 may be 11.5 mm. In an embodiment of the section shown in FIG. 26, h may be 12-15 mm, preferably 13.5 mm, r may be 5 mm, t may be 2 mm, b may be 3 mm, and w1 may be 11.5 mm. It is to be understood that these dimensions and ranges are merely exemplary and other dimensions and ranges are possible depending on application.

[0092] In the lower cheek regions 19 (see FIGS. 27-29), the underlying cushion 30 and base wall 28 has a relatively low spring constant. That is, the underlying cushion 30 in the lower cheek regions 19 is fairly soft since the fleshy cheek region of the patient deforms readily to form a seal with the cushion at relatively low forces. As illustrated, this arrangement is achieved by a greater height h, larger radii r, and a thinner underlying cushion wall. In an embodiment of the section shown in FIG. 27, h may be 14 mm, r1 may be 5 mm, r2 may be 7 mm, t may be 1.5-2 mm, b may be 3.5 mm, and w1 may be 11.5 mm. In an embodiment of the section shown in FIG. 28, h may be 16.5 mm, r1 may be 6-7 mm, r2 may be 8 mm, t may be 1.5 mm, b may be 3.5 mm, and w1 may be 11.5 mm. In an embodiment of the section shown in FIG. 29, h may be 17.5 mm, r1 may be 6-7 mm, r2 may be 9-10 mm, t may be 1.5 mm, b may be 3.5 mm, and w1 may be 11.5 mm. It is to be understood that these dimensions and ranges are merely exemplary and other dimensions and ranges are possible depending on application.

[0093] In the chin region 20 (see FIG. 14), no underlying cushion 30 is provided, although a very flexible spring region may be used. The chin region 20 provides an unconstrained membrane region that allows for lateral movement, mouth opening or movement, and a range of facial shapes.

[0094] Thus, the cushion 10 may be configured to provide different vertical and/or lateral stiffness in different regions of the cushion. For example, the side of nose regions 16, 17 are laterally stiffer than the other regions in order to provide more lateral stability at the patient's nose.

Alternative Embodiments of Base Wall and Underlying Cushion

[0095] FIGS. 30A-30N illustrate alternative embodiments of the base wall 28 and the underlying cushion 30. Each of these embodiments provides an arrangement that allows flexibility of the underlying cushion 30 in use. In FIG. 30A, the underlying cushion 30 defines an enclosed space 60 that may optionally be filled with pressurized air, foam, gel, or elastomeric material and adapted to dampen movement of the underlying cushion 30 in use. In FIG. 30B, the space 34 below the underlying cushion 30 is within the interior of the breathing cavity. Also, the underlying cushion 30 has an arcuate shape that curves away from the interior of the breathing cavity towards the base wall 28. However, the underlying cushion 30 may have any other suitable shape. For example, the underlying cushion 30 in FIG. 30C has a bulbous shape, which may be solid or hollow. In FIG. 30D, the underlying cushion 30 has a general Z-shape. In FIGS. 30E and 30F, the underlying cushion 30 has a bulbous shape (which may be solid or hollow), and the space 34 below the underlying

cushion 30 has a ramped configuration. In FIGS. 30C, 30E, and 30F, the bulbous shape may optionally be filled with pressurized air, foam gel, or elastomeric material and adapted to dampen movement of the underlying cushion 30 in use. In FIG. 30E the ramped configuration of the space 34 is adapted to direct the underlying cushion 30 downwardly into the base wall 28 in use, and in FIG. 30F the ramped configuration of the space 34 is adapted to direct the underlying cushion 30 inwardly towards the breathing cavity in use. In FIGS. 30G, 30H, and 30I, the underlying cushion 30 has a general T-shape. Also, in FIGS. 30H and 30I, the base wall 28 defines an enclosed space 62 below the T-shaped underlying cushion 30. The enclosed space 62 may be optionally filled with pressurized air, foam, gel, or elastomeric material and adapted to dampen movement of the underlying cushion 30 in use. Moreover, the spring constant may be varied by varying the pressure within the enclosed space 62. Additionally, the lower surface of the space 62 may have a ramped configuration (as shown in FIG. 30H) adapted to direct the underlying cushion 30 inwardly towards the breathing cavity in use. The lower surface of the enclosed space 60 in FIG. 30A may also have a ramped configuration for directing the underlying cushion 30 in use. In FIGS. 30J and 30K, the underlying cushion 30 has an elongated section length for soft spring characteristics. FIG. 30L illustrates a single wall construction with an underlying cushion 30 and no membrane. In FIG. 30M, the space 34 below the underlying cushion 30 is greatly increased. In FIG. 30N, a spring construction is provided below the base wall 28.

Displacement Provided by Underlying Cushion

[0096] The space 34 allows more displacement of the underlying cushion 30 for a predetermined amount of force when compared to the UltraMirage® cushion 700. That is, the underlying cushion 30 provides more movement for a given force. For example, FIG. 31 illustrates the general relationship between Force and Displacement for the cushion 10 and the UltraMirage® cushion 700. As illustrated, the curve for the cushion 10 is flatter than the exponential-type curve of the UltraMirage® cushion 700. Thus, the underlying cushion 30 is less stiff and more compliant when compared to the UltraMirage® cushion 700. It is noted that the space 34 could be filled with a gel, silicone or other structure to vary the spring characteristic that it provides.

[0097] Further, as illustrated in FIG. 31, the point B₁₀ at which the cushion 10 is fully compressed or bottomed-out is at a greater displacement than the point B₇₀₀ at which the UltraMirage® cushion 700 is bottomed-out. Moreover, the bottom-out point B₁₀ occurs at a greater force than the bottom-out point B₇₀₀. Thus, the cushion 10 increases the force required to bottom-out, and provides a wider range of adjustment. Additionally, FIG. 31 illustrates an example of maximum and minimum comfortable sealing forces, which provides an example force range necessary to achieve seal. As illustrated, the range of displacement A₁₀ within this force range for the cushion 10 is substantially larger than the range of displacement A₇₀₀ within this force range for the UltraMirage® cushion 700. Thus, the cushion 10 allows a wide range of adjustment or displacement to achieve seal, and ensures that the sealing force is substantially less than the bottom-out force so that the cushion does not have to bottom-out to seal.

[0098] FIG. 32 illustrates another embodiment of the relationship between Force and Displacement for the cushion 10 and the UltraMirage® cushion 700. In this embodiment, the

linear portion of the curve for cushion 10 has a greater slope than the linear portion of the curve for cushion 10 in FIG. 31. The difference in slope may be attributed to a difference in spring constants of respective underlying cushions 30. Thus, the cushion represented in FIG. 31 provides more displacement for a given force than the cushion represented in FIG. 32. Also, the curve for the cushion 10 in FIG. 32 intersects with the curve for the UltraMirage® cushion 700, such that the force of cushion 10 is higher at lower displacement, to ensure a seal, and lower at higher displacement, to maintain comfort for a longer range of displacement.

[0099] FIG. 33 illustrates another embodiment of the relationship between Force and Displacement for the cushion 10. In this embodiment, typical curves for the different regions of the cushion 10 are shown. Specifically, one curve represents the cross-sections of FIGS. 23-24 in the side of nose region 17, another curve represents the cross-sections of FIGS. 25-27 in upper cheek and lower cheek regions 18, 19, and yet another curve represents the cross-sections of FIGS. 28-29 in the lower cheek region 19. As illustrated, the cushion 10 is softer or less stiff in the lower regions of the cushion 10.

Extended Spring Length of Underlying Cushion

[0100] FIGS. 34A and 34B illustrate the extended length of the flexible underlying cushion 30 which is used to provide a softer spring characteristic in selected regions of the cushion 10 when compared with a typical prior art cushion, e.g., the UltraMirage® cushion 700. The length a to b can deform, thus providing a spring characteristic. As illustrated, the length a to b of the cushion 10 (FIG. 34A) is considerably longer when compared to the UltraMirage® cushion 700 (FIG. 34B) due to the curvature of the underlying cushion 30. In the illustrated embodiment, the length a to b of the cushion 10 is 22.84. However, in an embodiment, the length a to b of the cushion 10 may be in the range of 16-30, preferably 20-25, most preferably 22-24. In another embodiment, the length a to b of the cushion 10 may be in the range of 16-20. The length b to c is fairly rigid and does not deform to provide a spring characteristic. The added length in the cushion 10 has been achieved by the arcuate shape of the underlying cushion 30 and the space 34 is a result of this shape. This added length adds flexibility and a greater range of movement to the cushion 10. FIGS. 30J and 30K illustrate other embodiments for achieving a longer section length.

Configuration of Membrane in Nasal Bridge Region

[0101] The membrane 32 is structured to form an effective seal around nasal bridge, side of nose, upper cheek, lower cheek, and chin regions 16, 17, 18, 19, 20 of a patient. Another aspect of the invention relates to the configuration of the membrane 32 in the nasal bridge region 16 of the cushion 10, which has been structured to improve sealing and comfort in this region.

[0102] Specifically, as shown in a preferred embodiment in FIG. 36 and in an alternative embodiment in FIG. 68, the membrane 32 forms an elongated ridge 35 in the nasal bridge region 16 wherein sloping sides 36 meet to form an elongated crest 38. Each of the sloping sides 36 is angled from the crest centerline in the range of 30-60°, preferably about 47°. The crest 38 has a radius of curvature in the range of 1.0-5.0 mm, preferably about 2.5 mm. As illustrated, the underlying cushion 30 has been eliminated from beneath the membrane 32 in the nasal bridge region 16, which allows the membrane 32 in

this region to freely move between the underlying cushions 30 provided in the side of nose regions 17. As discussed in greater detail below, this membrane configuration allows the creation of a steeply inverted section upon engagement with the patient's nose, which improves fit, comfort, and seal in the nasal bridge region 16. In contrast, the UltraMirage® cushion 700 is relatively flat in this region (see FIG. 52).

[0103] As shown in a preferred embodiment in FIG. 37 and in an alternative embodiment in FIG. 69, the forward end 40 of the elongated ridge 35 has an arcuate configuration. The forward end 40 is structured to engage the patient's nasal bridge region and has a radius of curvature in the range of 1.5-7.0 mm, preferably about 4.0 mm.

Sharp Cross-Sectional Profile of Nasal Bridge Region

[0104] As shown in FIG. 10, the membrane 32 in the nasal bridge region 16 has a sharper cross-sectional profile than the corresponding portion of the UltraMirage® cushion 700 (see FIG. 48). Specifically, the membrane 32 provides a large contoured portion that curves inwardly towards the cavity of the cushion along a radius to terminate at an inner edge of the membrane 32. This arrangement more closely follows the contour or curvature of the patient's nasal bridge region. In the illustrated embodiment, the membrane 32 is angled with respect to a face contacting plane of the cushion, e.g., in the range of 30-50°. In contrast, the corresponding angle of the UltraMirage® cushion 700 is about 6°. This arrangement provides more comfort and a better fit for the patient.

Flat Portion in Nasal Bridge Region

[0105] As best shown in FIG. 38, the nasal bridge region 16 has a substantially flat portion 50, e.g., on the apex of the membrane curvature, in elevation view that may deform to provide a more comfortable fit for a wide range of patients, e.g., from flatter nasal bridges to sharper nasal bridges.

[0106] Specifically, one aspect of the invention is to provide a membrane 32 in the nasal bridge region 16 that will accommodate "flat faces", e.g., those patient's with a low nasal bridge. In order to achieve this, the cushion 10 has an upper point A which is higher than or level with points B (see FIG. 38). This height in the nasal bridge region 16 is combined with a rolled edge that keeps the surface area of the membrane 36 substantially flat against the patient's nasal bridge. Keeping the surface area of the membrane 36 substantially flat against the patient's nasal bridge prevents leaks at the edge of the membrane.

[0107] The rolled edge also allows movement to accommodate higher nasal bridges. This arrangement is achieved without "stretching" the membrane which can lead to discomfort and patient sores. For example, the displacement of the cushion 10 at the nasal bridge region 16 may be greater than about 40 mm, e.g., 41 mm. In contrast, the UltraMirage® cushion 700 provides displacement of about 20 mm in the nasal bridge region. At these displacements, the membrane becomes quite taut, i.e., the point on the force vs. displacement graph where the force begins to rise sharply for a small displacement (see FIG. 38B).

[0108] The displacement values of the cushion in the nasal bridge region for some prior art cushions are as follows:

[0109] ResMed™ Activa® Nasal Cushion—16 mm

[0110] Respiration Comfort Full Face Cushion—26 mm

[0111] ResMed Bubble Nasal Mask Cushion—43 mm

[0112] Healthdyne Soft Series Nasal Mask Cushion—17 mm

[0113] The above displacement values are by no means an accurate representation of what nose depth the cushion will cover. Rather, these displacement values are only an indication of the flexibility and/or range of the membrane. Thus, the cushion 10 provides an arrangement that is much more flexible and/or rangy than the UltraMirage® cushion 700, for example.

[0114] The force vs. displacement graph of membrane 32 in the nasal bridge region 16 has a large displacement for relatively low forces. For example, as shown in FIG. 38B, the displacement provided by the cushion 10 in the nasal bridge region 16 is larger than that provided by the UltraMirage® cushion 700. This allows the cushion 10 to accommodate relatively deep nasal bridges in use. Also, the molded (undeformed) cushion state of the UltraMirage® cushion 700 (i.e., no force applied) does not comfortably accommodate a relatively flat or shallow nasal bridge. In an embodiment, the membrane of the cushion 700 blows out to meet patient's faces with shallow nasal bridges. Thus, the cushion 10 also accommodates a wider range of nasal bridge shapes than the UltraMirage® cushion 700.

[0115] Further, as shown in FIG. 36, the profile of the membrane is more sharply peaked as compared to a flat profile or a saddle shape (e.g., compare with UltraMirage® cushion 700 in FIG. 52). Also, as shown in FIG. 35, flat portion in the nasal bridge region 16 extends along a relatively flat plane P1, and this plane P1 is angled at an angle A with respect to the plane P2 that defines the frame connection.

[0116] Thus, the shape (e.g., peak), the rolled edge, and the height, in the nasal bridge region 16 provide large displacement at relatively low forces. This arrangement accommodates a wider range of patients, e.g., from those with a low nasal bridge to those with a high nasal bridge, while maintaining a seal against the patient's face with little force on the membrane.

[0117] It is noted that the cushion height may vary around the cushion perimeter to vary flexibility or cushion displacement in different regions of the cushion. A reference dimension 940 for measurement of the cushion height (which may also be referred to as the membrane height)—i.e. the height between the apex of the membrane to where it meets the underlying cushion—is shown in FIG. 94C. A reference dimension 950 for measurement of the cushion height of the prior art cushion is shown in FIG. 95C.

Aperture in Membrane

[0118] As shown in FIGS. 39-40B, the inner edge of the membrane 32 defines the aperture 22 that receives the patient's nose and mouth. As illustrated, the aperture 22 has a generally triangular shape. Also, the apex of the aperture 22 has a rounded notch 42, e.g., keyhole. The notch 42 improves the seal with nasal bridge regions of various sizes and shapes, particularly patients with sharp noses. The notch 42 has a radius of curvature in the range of 1.5-6.0 mm, preferably about 3.0 mm. This rounded keyhole shape has a length, e.g., the keyhole shape extends outwards from an interior portion of the cushion, of at least 3.0 mm, as shown in FIG. 40A.

Rolling Action of Nasal Bridge Region of Cushion In Use

[0119] FIGS. 41-45 include hand-marked lines applied to the outer surface of the nasal bridge region 16 of the cushion

10 to illustrate the rolling action of the nasal bridge region 16 of the membrane 32 upon engagement with the patient's nose. As described above, the membrane 32 in the nasal bridge region 16 includes sloping sides 36 that meet to form an elongated crest 38 as shown in FIG. 41. As the patient's nasal bridge (simulated using a small rod) is engaged with the nasal bridge region 16 of the membrane 32 (see FIG. 42), the membrane 32 creates a steeply inverted section 44 wherein the sloping sides 36 invert their position as the membrane 32 moves between the underlying cushions 30 provided in the side of nose regions 17. As the membrane 32 comes more into contact with the patient's nasal bridge, the leading edge 46 of the inverted section "rolls" towards the top of the cushion 10 as the membrane 32 conforms to the patient's face as shown in FIG. 43. This structure is advantageous since it allows the cushion 10 to accommodate patients having a wide range of nasal profiles, including those with relatively low and relatively high root depth at the nose. FIGS. 44 and 45 show the nasal bridge region 16 of the membrane 32 in its completely inverted position. The creation of the steeply inverted section 44 upon engagement with the patient's nose provides a better seal and reduces the risk of creasing and/or folding and associated discomfort and leaks. That is, this configuration encourages rolling instead of creasing which can be detrimental to patient comfort and seal.

Alternative Embodiments

[0120] FIGS. 54-71 illustrate another embodiment of a cushion 510. In each of the figures, portions of the cushion 510 that are substantially similar to the cushion 10 are indicated with similar reference numerals.

[0121] FIG. 64 illustrates the base wall 528, underlying cushion 530, and membrane 532 of the cushion 510 (in solid lines) in relation to the base wall 728, underlying cushion 730, and membrane 732 of the UltraMirage® Full Face cushion 700 (in dashed lines). As illustrated, the cushion 510 has a different cross-sectional profile than the UltraMirage® Full Face cushion 700.

[0122] For example, the membrane 532 is connected to the underlying cushion 530 at a position that is further inwardly and upwardly with respect to the membrane connection of the UltraMirage® cushion 700. This arrangement substantially removes the vertically extending groove 731 provided in the UltraMirage® cushion 700. Also, this arrangement narrows the width of the membrane 532, e.g., in the range of 0-5, preferably about 2.5 mm, with respect to the corresponding portion of the UltraMirage® cushion 700. As a result of this and the inward movement of the non-face contacting portion 512, this narrows the total width of the cushion 510 by about 5 mm, e.g., about 2.5 mm per base, which provides a less obtrusive cushion and saves material. Also, the narrower membrane 532 provides less free length for the cushion 510 to bulge outwardly in use, thus helping to minimize or eliminate leakage. Further, the base wall 528 and the frame connection 529 are internally offset with respect to the most external cushion point, e.g., external surface of underlying cushion. FIG. 64 also shows the longer length a to b in the cushion 510 when compared to the UltraMirage® cushion 700.

[0123] FIG. 65 illustrates further structural details and dimensions in one embodiment of the base wall 528, underlying cushion 530, and membrane 532 of the cushion 510. For example, the depth of the space 534 is in the range of 0-4.0 mm, preferably about 3.0 mm.

[0124] FIG. 68 illustrates the elongated ridge 535 in the nasal bridge region 516. Each of the sloping sides 536 is angled from the crest centerline in the range of 30-60°, preferably about 47°. The crest 538 has a radius of curvature in the range of 1.0-5.0 mm, preferably about 2.5 mm. As shown in FIG. 69, the forward end 540 of the elongated ridge 535 has a radius of curvature in the range of 1.5-7.0 mm, preferably about 4.0 mm.

[0125] FIGS. 70 and 71 illustrate the flat portion 550 in the nasal bridge region 516 of the cushion 510. Also, as shown in FIG. 71, the membrane 532 in the nasal bridge region 516 has a first portion with a radius of curvature in the range of 50-80 mm, preferably about 65 mm, and a second portion with a radius of curvature in the range of 5.5-9.5 mm, preferably about 7.5 mm. In the illustrated embodiment, the membrane 532 is angled with respect to a face contacting plane of the cushion in the range of 30-50°, preferably about 40°.

[0126] FIGS. 72-76 illustrate another embodiment of a cushion 610. As best shown in FIG. 76, the cushion includes at least a base wall 628 and a membrane 632. As illustrated, the length of the membrane 632 (e.g., membrane cross-sectional length) in a nasal bridge region may change. For example, the membrane length may be selected to have a shorter length L_1 or a longer length L_2 in the nasal bridge region.

[0127] As shown in FIGS. 74 and 75, the membrane length controls how far on the patient's nose the displaced cushion membrane will sit when fitted onto the patient's face (shown by the dotted line on the patient's facial profile). This arrangement prevents the potential (e.g., particularly for patients with a shallow nasal bridge depth) for any excess cushion membrane to sit too far down on the patient's nose, which may lead to facial discomfort and skin markings on the patient's nose.

[0128] FIGS. 77-83 illustrate another embodiment of a cushion 810. The cushion 810 includes a base wall 828, an underlying support cushion 830, and a membrane 832. As described above, the underlying cushion 830 is preferably provided on lateral sides of the cushion 810 only.

[0129] The base wall 828 may be internally offset with respect to the most external cushion point, e.g., external surface of membrane or underlying cushion. This arrangement provides a spring characteristic which may be varied around the cushion perimeter to vary the cushion flexibility (lateral and/or vertical) around the cushion perimeter, e.g., the cushion stiffness can be varied at each cushion region to suit the sealing requirements in each region which may vary due to the underlying facial structure of the patient. That is, the level of bias (e.g., from "hard" to "soft") along the sides of the cushion may be changed.

[0130] For example, FIGS. 77-83 illustrate cross-sections through three different regions R1, R2, R3 in the cushion 810. As shown in FIG. 81, the base wall 828, the underlying cushion 830, and the membrane 832 cooperate to define a relatively straight external surface 880. This provides a minimal spring component in the region R1, e.g., hard or stiff characteristics.

[0131] As shown in FIG. 82, the base wall 828, the underlying cushion 830, and the membrane 832 cooperate to define an external surface 882 that transitions from a relatively straight configuration to a curved configuration. This provides a relatively small offset for a more flexible spring component than the region R1.

[0132] As shown in FIG. 83, the base wall 828, the underlying cushion 830, and the membrane 832 cooperate to define

an external surface 884 that curves outwards from the base wall 828. This provides a relatively large offset for an optimal spring component in the region R3, e.g., soft or flexible characteristics.

[0133] Thus, the cushion 810 may be designed to provide varying flexibilities around its perimeter which allows the cushion 810 to conform to a variety of facial shapes.

[0134] FIGS. 84-90 illustrate another embodiment of a cushion 910. The cushion 910 includes a base wall 928, an underlying support cushion 930, and a membrane 932. As illustrated, the underlying cushion 930 is preferably provided on lateral sides of the cushion 910 only, e.g., no underlying cushion at nasal bridge and chin regions (see FIG. 88).

[0135] As shown in FIG. 90, the base wall 928 includes a tapered portion 990 when compared to FIG. 89, which tapers towards the membrane 932. This arrangement may improve moldability.

[0136] FIG. 91 illustrates an alternative arrangement to the cushion 10 of FIG. 34A (arrangement of FIG. 34A shown in dashed lines). As illustrated, material has been removed from the side wall 28 and the space or gap 34 has been reduced with respect to the arrangement of FIG. 34A. This arrangement of FIG. 91 increases displacement with respect to the previous displacement of FIG. 34A. The increased displacement is achieved by the changed geometry in the side wall 28. It is noted that the gap 34 may be variable or constant around the cushion perimeter.

[0137] FIG. 92 illustrates an alternative arrangement to the cushion 10 of FIG. 34A (arrangement of FIG. 34A shown in dashed lines). As illustrated, some material has been removed from the side wall 28 and the space or gap 34 has been reduced with respect to the arrangement of FIG. 34A. This arrangement of FIG. 92 increases displacement with respect to the previous displacement of FIG. 34A. The increased displacement is achieved by the changed geometry in the side wall 28. This arrangement may require the cross-section of the base wall 28 to be thickened to add stiffness around the cushion perimeter or locally. Stiffening may be achieved by local ribs where required.

[0138] FIG. 93 illustrates an alternative arrangement to the cushion 10 shown in FIG. 15. As illustrated, the keyhole-shaped cutout (for receiving the patient's nasal bridge region) may be larger as the mask size reduces. For example, the cutout is larger for an extra small size mask than a large size mask.

[0139] It is noted that the cross-section design of the cushion at specific areas of the patient's face (e.g., FIGS. 23-29) may be in the specific area or any area around the cushion perimeter. That is, the cross-section design should not be limited to the specified area. Also, the cross-section shown in FIGS. 91 and 92 may be employed at any point around the cushion perimeter.

[0140] While the invention has been described in connection with what are presently considered to be the most practical and preferred embodiments, it is to be understood that the invention is not to be limited to the disclosed embodiments, but on the contrary, is intended to cover various modifications and equivalent arrangements included within the spirit and scope of the invention. Also, the various embodiments described above may be implemented in conjunction with other embodiments, e.g., aspects of one embodiment may be combined with aspects of another embodiment to realize yet other embodiments. In addition, while the invention has particular application to patients who suffer from

OSA, it is to be appreciated that patients who suffer from other illnesses (e.g., congestive heart failure, diabetes, morbid obesity, stroke, bariatric surgery, etc.) can derive benefit from the above teachings. Moreover, the above teachings have applicability with patients and non-patients alike in non-medical applications.

What is claimed is:

1. A method of making a series of full-face cushions for patient interfaces that deliver breathable gas to patients, each of the full-face cushions including a nasal bridge region, cheek regions and a chin region, each of the full-face cushions defining, at least in part, a breathing cavity, the method comprising:

making a first full-face cushion, the first full-face cushion comprising a first membrane including a first nasal bridge region, first cheek regions and a first chin region forming a first continuous sealing structure to form a continuous seal on a nasal bridge region, cheek regions, and a chin region of the patient's face, the first membrane having an inner edge that defines a first triangular-shaped aperture to receive the patient's nose and mouth, the first triangular-shaped aperture including a lower portion having a first mouth width;

making a second full-face cushion, the second full-face cushion comprising a second membrane including a second nasal bridge region, second cheek regions and a second chin region forming a second continuous sealing structure to form a continuous seal on a nasal bridge region, cheek regions, and a chin region of the patient's face, the second membrane having an inner edge that defines a second triangular-shaped aperture to receive the patient's nose and mouth, the second triangular-shaped aperture including a lower portion having a second mouth width;

making a third full-face cushion, the third full-face cushion comprising a third membrane including a third nasal bridge region, third cheek regions and a third chin region forming a third continuous sealing structure to form a continuous seal on a nasal bridge region, cheek regions, and a chin region of the patient's face, the third membrane having an inner edge that defines a third triangular-shaped aperture to receive the patient's nose and mouth, the third triangular-shaped aperture including a lower portion having a third mouth width; and

making a fourth full-face cushion, the fourth full-face cushion comprising a fourth membrane including a fourth nasal bridge region, fourth cheek regions and a fourth chin region forming a fourth continuous sealing structure to form a continuous seal on a nasal bridge region, cheek regions, and a chin region of the patient's face, the fourth membrane having an inner edge that defines a fourth triangular-shaped aperture to receive the patient's nose and mouth, the fourth triangular-shaped aperture including a lower portion having a fourth mouth width,

wherein each of the first, second, third and fourth triangular-shaped apertures has a different height, the first mouth width is within 5 mm of the second, third and fourth mouth widths, the second mouth width is within 5 mm of the third and fourth mouth widths, and the third mouth width is within 5 mm of the fourth mouth width.

2. The method of claim 1, wherein each of the first, second, third and fourth full-face cushions includes a support structure, each support structure including:

a wall; and

an underlying cushion connected to the wall,

wherein each underlying cushion, in a cross-sectional view, extends from a respective wall and toward a respective breathing cavity to provide support to a respective one of the first, second, third and fourth membranes, each underlying cushion includes cheek regions extending adjacent a perimeter of a respective one of the first, second, third and fourth triangular-shaped apertures such that each respective full-face cushion has at least a double-walled construction in the cheek regions such that each underlying cushion is positioned to restrain movement of a respective one of the first, second, third and fourth membranes, and each respective full-face cushion has only a single-walled construction in at least a portion of the chin region so as to allow each respective membrane to readily flex in said at least a portion of the chin region.

3. The method of claim 2, wherein each wall has a top portion and a bottom portion, each of the first, second, third and fourth membranes or each respective support structure forms a widest point of the respective full-face cushion, and the bottom portion of each wall is internally offset with respect to the widest point of the respective full-face cushion.

4. The method of claim 3, wherein the making of the first, second, third and fourth full-face cushions comprises molding at least a portion of the first, second, third and fourth full-face cushions.

5. The method of claim 4, wherein a first cross-sectional configuration of the support structure in the nasal bridge region of each full-face cushion is different than a second cross-sectional configuration of the support structure in the cheek regions of the respective full-face cushion.

6. The method of claim 5, wherein a third cross-sectional configuration of the support structure in a lower facial area of the cheek regions of each full-face cushion is different than a fourth cross-sectional configuration of the support structure in an upper facial area of the cheek regions of the respective full-face cushion.

7. The method of claim 6, wherein the first and second cross-sectional configurations of the support structure in the nasal bridge region and the cheek regions of each respective full-face cushion vary by varying an underlying cushion offset.

8. The method of claim 7, wherein each of the first, second, third and fourth full-face cushions is dimensioned to fit respective first, second, third and fourth ranges of the patients, the mouth widths of the first, second, third and fourth triangular-shaped apertures are at a widest point of the first, second, third and fourth triangular-shaped apertures, and the height of each of the first, second, third and fourth triangular-shaped apertures is at a tallest point of the first, second, third and fourth triangular-shaped apertures, and

wherein the first full-face cushion is a large size full-face cushion, the second full-face cushion is a medium size full-face cushion, the third full-face cushion is a small size full-face cushion and the fourth full-face cushion is a size that is smaller than the third full-face cushion.

9. The method of claim 8, wherein a first portion of each support structure extends laterally beyond a second exterior portion of a respective one of the first, second, third and fourth full-face cushions, and

wherein:

the first portion of each support structure is movable with respect to the respective second exterior portion when the respective full-face cushion is worn and a force is exerted on the respective full-face cushion, the first portion of each support structure is movable from an initial position towards a space exterior of the respective full-face cushion when the force is applied, and

the first portion of each support structure is configured to resiliently move back into the initial position when the force is no longer exerted on the respective full-face cushion.

10. The method of claim **9**, wherein each of the first, second, third and fourth full-face cushions is adapted to exert a spring force when the force is applied such that the first portion of each support structure is configured to resiliently move back into the initial position when the force is no longer exerted on the respective full-face cushion, and

wherein at least a portion of each support structure has a variable spring characteristic around a perimeter of the respective full-face cushion.

11. The method of claim **10**, wherein the first, third and fourth cross-sectional configurations of each support structure vary from one another so as to provide different spring constants in the nasal bridge region, the lower facial area of the cheek regions and the upper facial area of the cheek regions of each respective full-face cushion.

12. The method of claim **11**, wherein each of the first, second, third and fourth mouth widths is substantially the same as each one of the other first, second, third and fourth mouth widths.

13. The method of claim **11**, wherein each of the first, second, third and fourth membranes, in a respective nasal bridge region, includes a contoured portion that curves inwardly and terminates at the inner edge of the respective membrane, each contoured portion being configured to follow a contour or curvature of the patient's nasal bridge region.

14. The method of claim **11**, wherein at least a portion of each underlying cushion forms the respective first portion of each support structure, and a respective one of the first, second, third and fourth membranes extends from each underlying cushion,

wherein each underlying cushion includes a nasal bridge region such that each underlying cushion is continuous along the cheek regions and the nasal bridge region of the respective underlying cushion, and

wherein each of the first, second, third and fourth membranes has a height in the nasal bridge region of a respective one of the first, second, third and fourth full-face cushions that is greater than a height of the respective membrane in the cheek regions of the respective full-face cushion.

15. The method of claim **11**, wherein at least a portion of each wall forms the respective first portion of each support structure, and a respective one of the first, second, third and fourth membranes extends from each wall,

wherein each underlying cushion includes a nasal bridge region such that each underlying cushion is continuous along the cheek regions and the nasal bridge region of the respective underlying cushion, and

wherein each of the first, second, third and fourth membranes has a height in the nasal bridge region of a respective one of the first, second, third and fourth full-face

cushions that is greater than a height of the respective membrane in the cheek regions of the respective full-face cushion.

16. A method of making a series of full-face cushions for patient interfaces that deliver breathable gas to patients, each of the full-face cushions including a nasal bridge region, cheek regions and a chin region, each of the full-face cushions defining, at least in part, a breathing cavity, the method comprising:

making a first full-face cushion, the first full-face cushion comprising a first membrane including a first nasal bridge region, first cheek regions and a first chin region forming a first continuous sealing structure to form a continuous seal on a nasal bridge region, cheek regions, and a chin region of the patient's face, the first membrane having an inner edge that defines a first triangular-shaped aperture to receive the patient's nose and mouth, the first triangular-shaped aperture including a lower portion having a first mouth width; and

making a second full-face cushion, the second full-face cushion comprising a second membrane including a second nasal bridge region, second cheek regions and a second chin region forming a second continuous sealing structure to form a continuous seal on a nasal bridge region, cheek regions, and a chin region of the patient's face, the second membrane having an inner edge that defines a second triangular-shaped aperture to receive the patient's nose and mouth, the second triangular-shaped aperture including a lower portion having a second mouth width,

wherein a height of the first triangular-shaped aperture is different than a height of the second triangular-shaped aperture, and the first mouth width is substantially the same as the second mouth width.

17. The method of claim **16**, further comprising:

making a third full-face cushion, the third full-face cushion comprising a third membrane including a third nasal bridge region, third cheek regions and a third chin region forming a third continuous sealing structure to form a continuous seal on a nasal bridge region, cheek regions, and a chin region of the patient's face, the third membrane having an inner edge that defines a third triangular-shaped aperture to receive the patient's nose and mouth, the third triangular-shaped aperture including a lower portion having a third mouth width,

wherein a height of the third triangular-shaped aperture is different than the heights of the first and second triangular-shaped apertures, and the third mouth width is within 5 mm of the first and second mouth widths.

18. The method of claim **17**, further comprising:

making a fourth full-face cushion, the fourth full-face cushion comprising a fourth membrane including a fourth nasal bridge region, fourth cheek regions and a fourth chin region forming a fourth continuous sealing structure to form a continuous seal on a nasal bridge region, cheek regions, and a chin region of the patient's face, the fourth membrane having an inner edge that defines a fourth triangular-shaped aperture to receive the patient's nose and mouth, the fourth triangular-shaped aperture including a lower portion having a fourth mouth width,

wherein a height of the fourth triangular-shaped aperture is different than the heights of the first, second and third

triangular-shaped apertures, and the fourth mouth width is within 5 mm of the first, second and third mouth widths.

19. The method of claim **18**, wherein each of the first, second, third and fourth full-face cushions includes a support structure, each support structure including:

a wall; and

an underlying cushion connected to the wall,

wherein each underlying cushion, in a cross-sectional view, extends from a respective wall and toward a respective breathing cavity to provide support to a respective one of the first, second, third and fourth membranes, each underlying cushion includes cheek regions extending adjacent a perimeter of a respective one of the first, second, third and fourth triangular-shaped apertures such that each respective full-face cushion has at least a double-walled construction in the cheek regions such that each underlying cushion is positioned to restrain movement of a respective one of the first, second, third and fourth membranes, and each respective full-face cushion has only a single-walled construction in at least a portion of the chin region so as to allow each respective membrane to readily flex in said at least a portion of the chin region.

20. The method of claim **19**, wherein each wall has a top portion and a bottom portion, each of the first, second, third and fourth membranes or each respective support structure forms a widest point of the respective full-face cushion, and the bottom portion of each wall is internally offset with respect to the widest point of the respective full-face cushion.

21. The method of claim **20**, wherein a first cross-sectional configuration of the support structure in the nasal bridge region of each full-face cushion is different than a second cross-sectional configuration of the support structure in the cheek regions of the respective full-face cushion.

22. The method of claim **21**, wherein a first portion of each support structure extends laterally beyond a second exterior portion of a respective one of the first, second, third and fourth full-face cushions, and

wherein:

the first portion of each support structure is movable with respect to the respective second exterior portion when the respective full-face cushion is worn and a force is exerted on the respective full-face cushion,

the first portion of each support structure is movable from an initial position towards a space exterior of the respective full-face cushion when the force is applied, and

the first portion of each support structure is configured to resiliently move back into the initial position when the force is no longer exerted on the respective full-face cushion.

23. The method of claim **22**, wherein the first and second cross-sectional configurations of each support structure vary

from one another so as to provide a spring constant in the nasal bridge region of each respective full-face cushion that is different than a spring constant in the cheek regions of the respective full-face cushion.

24. The method of claim **23**, wherein the first and second cross-sectional configurations of the support structure in the nasal bridge region and the cheek regions of each respective full-face cushion vary by varying an underlying cushion offset.

25. The method of claim **24**, wherein each of the first, second, third and fourth full-face cushions is dimensioned to fit respective first, second, third and fourth ranges of the patients, the mouth widths of the first, second, third and fourth triangular-shaped apertures are at a widest point of the first, second, third and fourth triangular-shaped apertures, and the height of each of the first, second, third and fourth triangular-shaped apertures is at a tallest point of the first, second, third and fourth triangular-shaped apertures, and

wherein the first full-face cushion is a large size full-face cushion, the second full-face cushion is a medium size full-face cushion, the third full-face cushion is a small size full-face cushion and the fourth full-face cushion is a size that is smaller than the third full-face cushion.

26. The method of claim **25**, wherein each of the first, second, third and fourth mouth widths is substantially the same as each one of the other first, second, third and fourth mouth widths.

27. The method of claim **26**, wherein each of the first, second, third and fourth membranes, in the nasal bridge region, has a substantially flat portion in elevation view.

28. The method of claim **25**, wherein each of the first, second, third and fourth membranes has a height in the nasal bridge region of a respective one of the first, second, third and fourth full-face cushions that is greater than a height of the respective membrane in the cheek regions of the respective full-face cushion.

29. The method of claim **28**, wherein at least a portion of each underlying cushion forms the respective first portion of each support structure, and a respective one of the first, second, third and fourth membranes extends from each underlying cushion, and

wherein each underlying cushion includes a nasal bridge region such that each underlying cushion is continuous along the cheek regions and the nasal bridge region of the respective underlying cushion.

30. The method of claim **28**, wherein at least a portion of each wall forms the respective first portion of each support structure, and a respective one of the first, second, third and fourth membranes extends from each wall, and

wherein each underlying cushion includes a nasal bridge region such that each underlying cushion is continuous along the cheek regions and the nasal bridge region of the respective underlying cushion.

* * * * *