

(19)



(11)

EP 4 397 888 A3

(12)

EUROPEAN PATENT APPLICATION

(88) Date of publication A3:
11.09.2024 Bulletin 2024/37

(51) International Patent Classification (IPC):
B64C 25/40 (2006.01) **F16B 5/10** (2006.01)
F16B 21/02 (2006.01) **F16B 21/09** (2006.01)
F16H 55/10 (2006.01)

(43) Date of publication A2:
10.07.2024 Bulletin 2024/28

(52) Cooperative Patent Classification (CPC):
B64C 25/405; F16B 5/10; F16H 55/10; F16B 21/02;
F16H 57/0427; F16H 57/0464; F16H 57/0471

(21) Application number: **24176853.0**

(22) Date of filing: **16.03.2015**

(84) Designated Contracting States:
AL AT BE BG CH CY CZ DE DK EE ES FI FR GB
GR HR HU IE IS IT LI LT LU LV MC MK MT NL NO
PL PT RO RS SE SI SK SM TR

(72) Inventors:
• **DIDEY, Arnaud**
Bristol, BS34 7PA (GB)
• **BILLYEALD, Richard**
Bristol, BS34 7PA (GB)
• **DICKASON, Ian**
Bristol, BS34 7PA (GB)
• **SETTER, James**
Bristol, BS34 7PA (GB)

(30) Priority: **17.03.2014 GB 201404727**

(62) Document number(s) of the earlier application(s) in accordance with Art. 76 EPC:
15714893.3 / 3 119 671

(74) Representative: **Abel & Imray LLP**
Westpoint Building
James Street West
Bath BA1 2DA (GB)

(71) Applicant: **Airbus Operations Limited**
Bristol BS34 7PA (GB)

(54) **ROLLER GEAR FOR A DRIVE SYSTEM**

(57) A roller gear for use in a roller gear and sprocket configuration of a drive system is disclosed, particularly for use in a landing gear drive system of an aircraft. Al-

ternative embodiments and, in particular, means for permitting removal and replacement of rollers and roller mounting pins in the roller gear are disclosed.

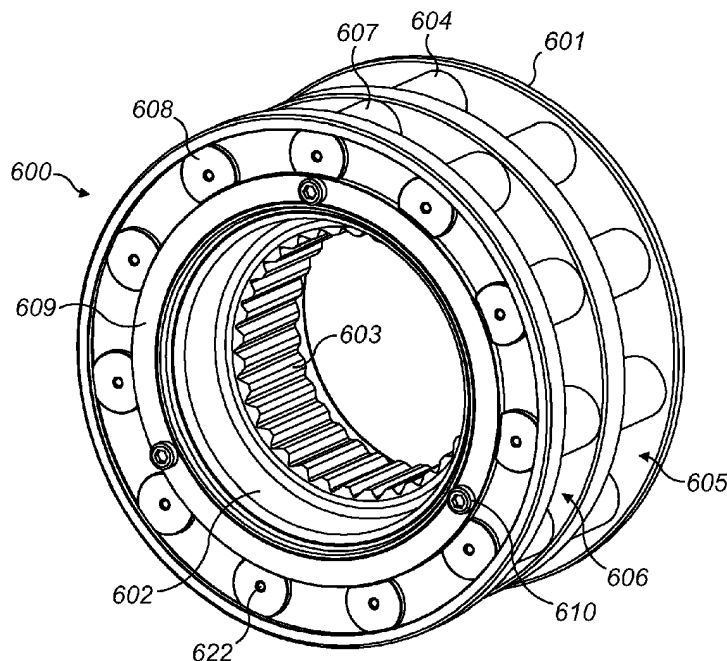

FIG. 6

EP 4 397 888 A3



EUROPEAN SEARCH REPORT

Application Number

EP 24 17 6853

5

DOCUMENTS CONSIDERED TO BE RELEVANT

10

15

20

25

30

35

40

45

50

55

Category	Citation of document with indication, where appropriate, of relevant passages	Relevant to claim	CLASSIFICATION OF THE APPLICATION (IPC)
X	US 1 200 203 A (KROYER JOHN M [US]) 3 October 1916 (1916-10-03)	1,3-5, 8-10,12, 14,15	INV. B64C25/40 F16B5/10
Y	* figures 1,2 *	1,3-5, 8-10,12, 14,15	F16B21/02 F16B21/09 F16H55/10
A		2,6,7, 11,13	
Y	----- GB 18536 A A.D. 1911 (SCHNEIDER MAX [DE]) 8 August 1912 (1912-08-08)	1,3-5, 8-10,12, 14,15	
	* the whole document *		
A	----- BE 517 599 A (ROLLS-ROYCE LIMITED) 28 February 1953 (1953-02-28) * figure 3 *	1-15	
A	----- US 1 289 508 A (MELCHER LEE W [US]) 31 December 1918 (1918-12-31) * figures 1,2 *	1-15	
A	----- US 860 536 A (ELLINGHAM ROBERT W [US]) 16 July 1907 (1907-07-16) * figures *	1-15	TECHNICAL FIELDS SEARCHED (IPC) B64C F16H F16B
A	----- US 594 110 A (HIGGINS FRANK L.) 23 November 1897 (1897-11-23) * figures *	1-15	

1

The present search report has been drawn up for all claims

50

Place of search

Date of completion of the search

Examiner

Munich

25 July 2024

Pedersen, Kenneth

EPO FORM 1503 03:82 (F04C01)

CATEGORY OF CITED DOCUMENTS

X : particularly relevant if taken alone
 Y : particularly relevant if combined with another document of the same category
 A : technological background
 O : non-written disclosure
 P : intermediate document

T : theory or principle underlying the invention
 E : earlier patent document, but published on, or after the filing date
 D : document cited in the application
 L : document cited for other reasons

 & : member of the same patent family, corresponding document

**ANNEX TO THE EUROPEAN SEARCH REPORT
ON EUROPEAN PATENT APPLICATION NO.**

EP 24 17 6853

5 This annex lists the patent family members relating to the patent documents cited in the above-mentioned European search report.
The members are as contained in the European Patent Office EDP file on
The European Patent Office is in no way liable for these particulars which are merely given for the purpose of information.

25-07-2024

Patent document cited in search report	Publication date	Patent family member(s)	Publication date
US 1200203 A	03-10-1916	NONE	

GB 191118536 A	08-08-1912	NONE	

BE 517599 A	28-02-1953	BE 517599 A	28-02-1953
		CH 310919 A	15-11-1955
		FR 1074845 A	08-10-1954
		GB 715086 A	08-09-1954
		US 2764266 A	25-09-1956

US 1289508 A	31-12-1918	NONE	

US 860536 A	16-07-1907	NONE	

US 594110 A	23-11-1897	NONE	

EPO FORM P0459

For more details about this annex : see Official Journal of the European Patent Office, No. 12/82