



US 20130098591A1

(19) **United States**

(12) **Patent Application Publication**

Taras et al.

(10) **Pub. No.: US 2013/0098591 A1**

(43) **Pub. Date: Apr. 25, 2013**

(54) **ALUMINUM FIN AND TUBE HEAT EXCHANGER**

Related U.S. Application Data

(60) Provisional application No. 61/367,688, filed on Jul. 26, 2010, provisional application No. 61/368,075, filed on Jul. 27, 2010.

(76) Inventors: **Michael F. Taras**, Fayetteville, NY (US); **Jason Scarcella**, Cicero, NY (US); **Bruce J. Poplawski**, Mattydale, NY (US); **Jack L. Esformes**, Jamesville, NY (US); **Mary T. Lombardo**, Windsor, CT (US); **Thomas J. Garosshen**, Glastonbury, CT (US)

Publication Classification

(51) **Int. Cl.**
F28F 1/10 (2006.01)
(52) **U.S. Cl.**
CPC **F28F 1/10** (2013.01)
USPC **165/181**

(21) Appl. No.: **13/704,723**

(22) PCT Filed: **Jul. 21, 2011**

(86) PCT No.: **PCT/US11/44788**

§ 371 (c)(1),
(2), (4) Date: **Dec. 17, 2012**

(57) **ABSTRACT**

A heat exchanger (10) is provided including at least one aluminum alloy tube (12) and a plurality of aluminum fins (26) arrayed on the aluminum alloy tube. The aluminum tube may be supported by tube sheets (24) made of aluminum alloy.

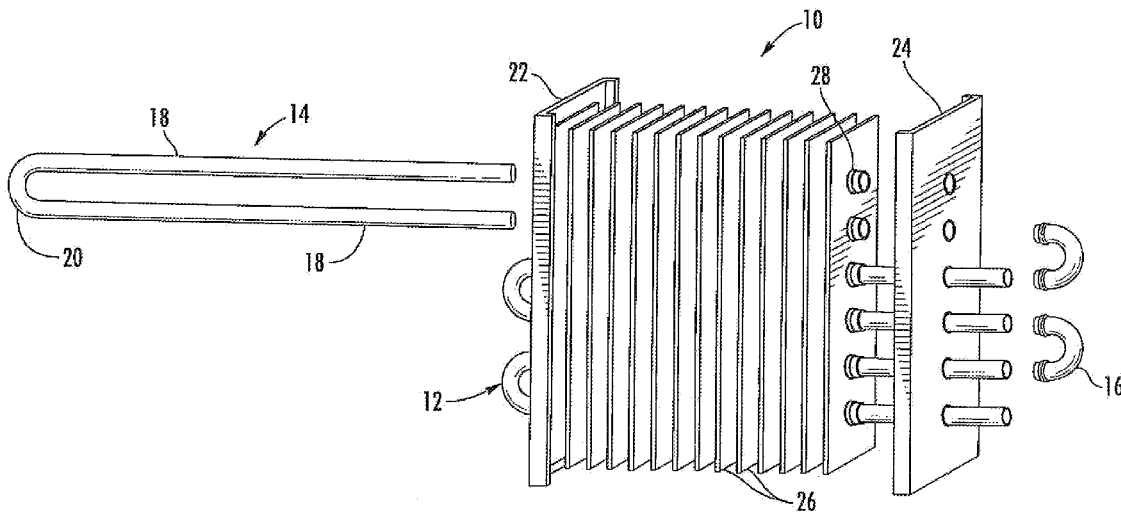

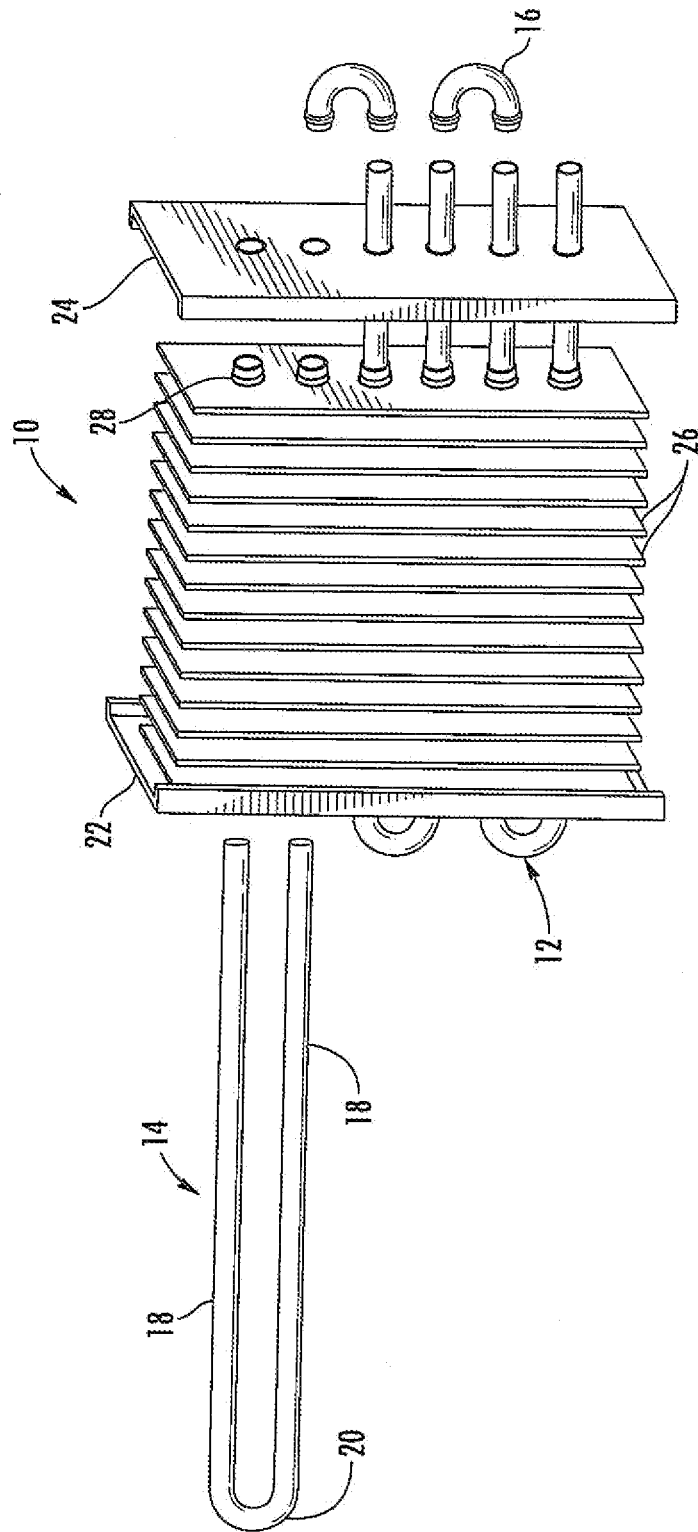

FIG. 1

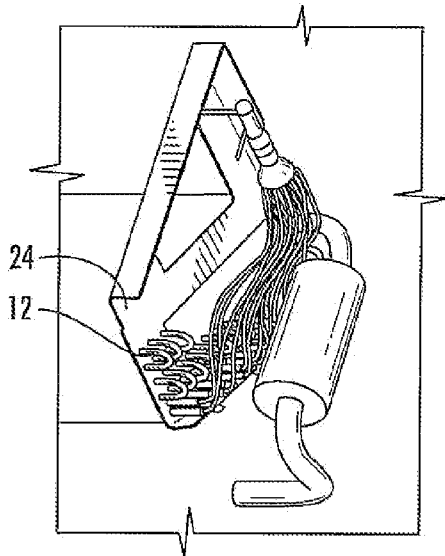

FIG. 2

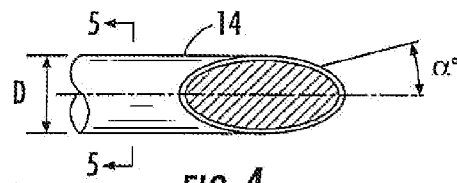

FIG. 4

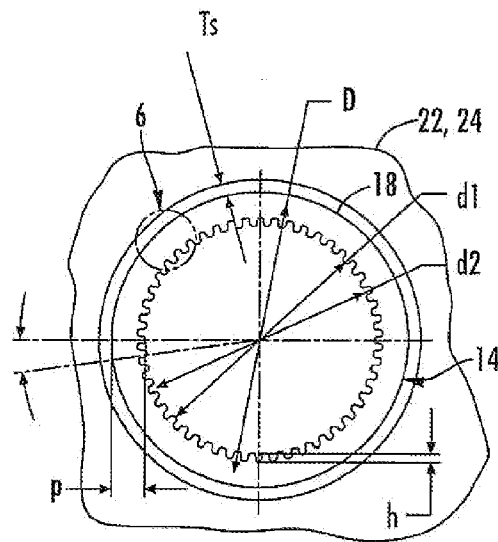

FIG. 5

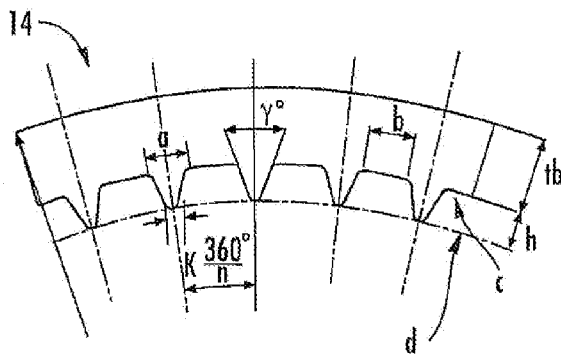

FIG. 6

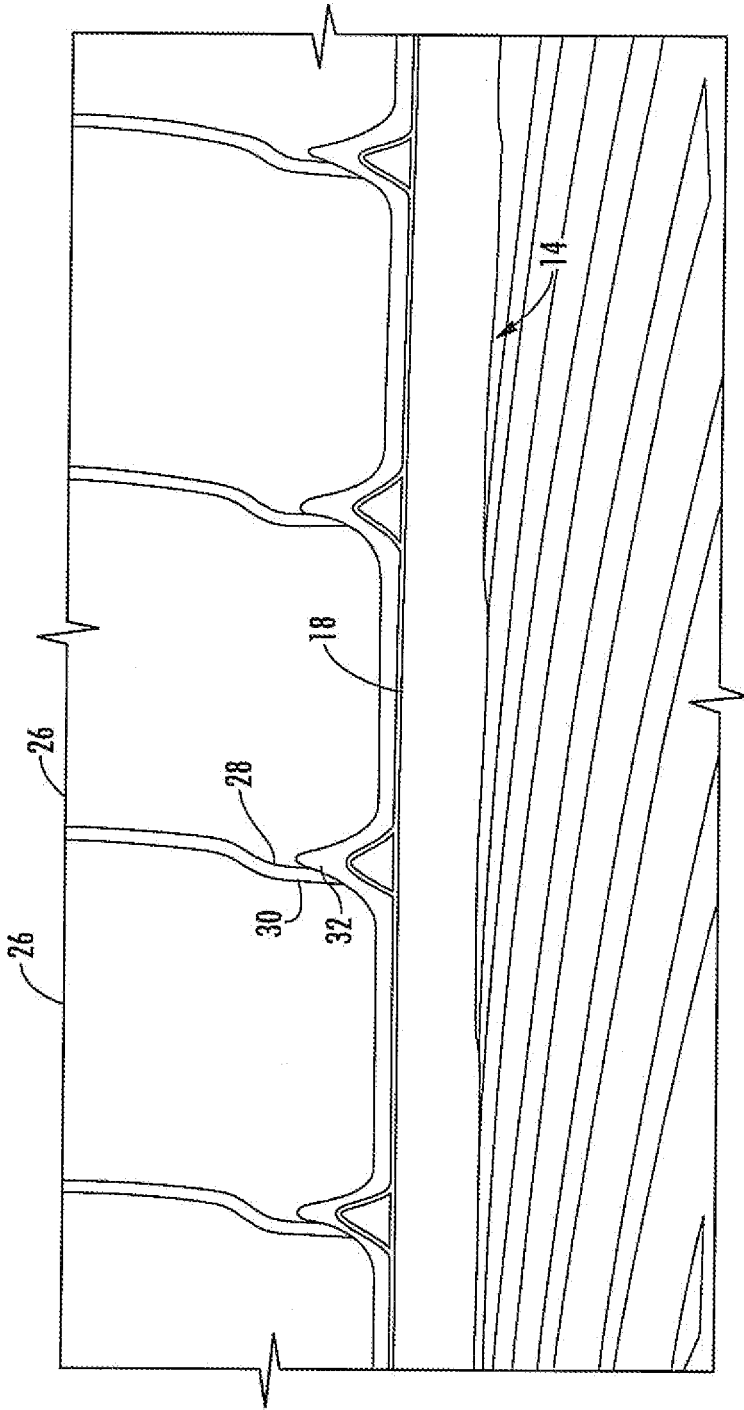

FIG. 3

ALUMINUM FIN AND TUBE HEAT EXCHANGER

CROSS-REFERENCE TO RELATED APPLICATION

[0001] This application claims priority to U.S. Provisional Patent Application Ser. No. 61/367,688, entitled "Aluminum Fin and Tube Heat Exchanger," filed on Jul. 26, 2010 and U.S. Provisional Patent Application Ser. No. 61/368,075, entitled "Aluminum Fin and Tube Heat Exchanger," filed on Jul. 27, 2010. The content of these applications are incorporated herein by reference in their entirety.

FIELD OF THE INVENTION

[0002] This invention relates generally to fin and tube heat exchangers and, more particularly, to a corrosion resistant, all aluminum alloy fin and tube evaporator heat exchanger particularly suitable for use in connection with transport refrigeration units.

BACKGROUND OF THE INVENTION

[0003] Perishable cargo, such as fresh produce, fresh and frozen meat, poultry, seafood and other foods, are commonly shipped in the temperature-controlled cargo box of a truck, a trailer or a transport container. Containers of this type are typically designed to accommodate transport by road on trailers, by sea on container ships, by rail on flat-bed train cars and even by air in cargo planes. In conventional industry practice, the truck, trailer or container transporting the perishable cargo is equipped with a refrigeration unit for maintaining the cargo box at a temperature within a specified temperature range to maintain freshness and minimize spoilage during transit. The refrigeration unit is mounted to one wall, typically the front wall, of the cargo box of the truck, trailer or container.

[0004] The refrigeration unit includes a compressor and a condenser unit isolated from the cargo box, and an evaporator unit including a tubular heat exchanger, commonly a tube and fin heat exchanger, operatively associated with the cargo box of the truck, trailer, or the container. Air drawn from the cargo box is passed over the evaporator heat exchanger in heat exchange relationship with refrigerant circulating through the tubes of the heat exchanger whereby the air is cooled prior to being supplied back to the cargo box.

[0005] Conventional evaporator heat exchangers used in transport refrigeration units have round tube and plate fin construction incorporating copper tubes and aluminum fins. For example, U.S. Pat. Nos. 6,325,138 and 6,578,628, assigned to Carrier Corporation disclose round tube and plate fin heat exchangers having copper tubes and aluminum fins having improved resistance to galvanic corrosion. To enhance heat exchange, the copper tubes typically have internal enhancements and aluminum fins encompass wavy design, to augment heat transfer on the refrigerant side and on the air side respectively. The price of internally grooved copper tubes is highly volatile as it follows the raw copper material price and represents a major component of the heat exchanger cost. Additionally, copper is three times as dense as aluminum. Thus, for conventional copper tube and aluminum fin heat exchangers, the heat exchanger weight is primarily controlled by the copper tube weight.

[0006] Aluminum tubes are commercially available, but are not currently used in transport refrigeration applications

due to a number of factors, including not only concern over corrosion in transport refrigeration applications, and the reduced tensile strength of aluminum versus copper and thicker wall required for the identical burst strength, but also due to the increased thermal expansion of aluminum versus copper, the brazing sensitivity for Al/Al joints due to challenging geometries and Al alloy melting temperature being very close to the braze alloy melting temperature, and the susceptibility of aluminum to fatigue and fretting due to high vibration levels.

[0007] Accordingly, the desire exists for a heat exchanger having an all aluminum alloy construction, i.e. a heat exchanger having aluminum alloy tubes, aluminum alloy fins and aluminum alloy tube sheets, that has acceptable corrosion resistance for use in transport refrigeration applications, lower weight and substantially the same heat transfer performance as conventional copper tube and aluminum fin heat exchangers used in transport refrigeration units.

SUMMARY OF THE INVENTION

[0008] A heat exchanger includes at least one tube having a longitudinally extending tube length and a plurality of heat exchange fins arrayed on the at least one tube. The at least one tube is made of a first aluminum alloy having a first galvanic potential and the plurality of heat exchange fins are made of a second aluminum alloy having a second galvanic potential. The second galvanic potential is higher than the first galvanic potential whereby the fins are sacrificial with respect to the tube. In an embodiment, the difference in galvanic potential between the second aluminum alloy and the first aluminum alloy is greater than about 20 millivolts.

[0009] In an aspect, a heat exchanger includes at least one serpentine tube having a plurality of longitudinally extending tube lengths and a plurality of heat exchange fins arrayed on the at least one tube. Adjacent fins of the arrayed plurality of heat exchange fins have interlocking collars disposed about and contacting the at least one tube. The interlocking collars collectively form a protective layer about the at least one tube. The fins may be made of an aluminum alloy having a greater galvanic potential relative to the tube in contact therewith whereby the protective layer becomes a galvanically sacrificial layer relative to the tube.

BRIEF DESCRIPTION OF THE DRAWINGS

[0010] For a further understanding of the disclosure, reference will be made to the following detailed description which is to be read in connection with the accompanying drawing, wherein:

[0011] FIG. 1 is a perspective view, partly exploded, illustrating a single bank of a fin and tube heat exchanger;

[0012] FIG. 2 is a perspective view of the return bend end of the assembled heat exchanger of FIG. 1;

[0013] FIG. 3 is an elevation view in section of the fin and tube interface of an exemplary embodiment of an aluminum tube and aluminum fin heat exchanger in accordance with the disclosure herein;

[0014] FIG. 4 is a sectional view through an internally grooved aluminum tube of an embodiment of the heat exchanger disclosed herein;

[0015] FIG. 5 is a cross-section view of the internally grooved tube taken substantially along line 5-5 of FIG. 4; and

[0016] FIG. 6 is an elevation view of an enlarged section of the internally grooved tube of FIG. 5.

DETAILED DESCRIPTION OF THE INVENTION

[0017] Referring initially to FIGS. 1 and 2 of the drawing, there is depicted an exemplary embodiment of a round tube and plate heat exchanger 10 of the general type commonly used as an evaporator in transport refrigeration systems showing one serpentine tube bank 12. It is to be understood that the typical heat exchanger 10 will have a plurality of serpentine tube banks 12 disposed in laterally spaced relationship, for example, as depicted in FIG. 2. The serpentine tube 12 is formed of a plurality of hairpin tube sections 14 connected in fluid flow communication by return bends 16. Each hairpin tube section 14 has a pair of generally parallel longitudinally extending tube lengths 18 and a hairpin U-bend 20. Tube sheets 22 and 24, which are disposed in spaced relationship at opposite ends of the longitudinally extending tube lengths 18, are penetrated by each tube length 18 of the plurality of tube banks 12 and provide structural support for the tube banks. It is to be understood that two straight tube sections connected by a return bend 16 can substitute for a single hairpin tube section 14. Further, one or more intermediate tube sheets may be incorporated in the heat exchanger 10.

[0018] The heat exchanger 10 includes a plurality of fins 26 disposed in parallel spaced relationship and extending transversely to the longitudinally extending tube lengths 18. Each fin 26 comprises a sheet-like plate fin having an array of openings therein, each opening for accommodating a tube length 18 penetrating therethrough when the heat exchanger 10 is assembled. To assemble the heat exchanger 10, each fin 26 of the plurality of sheet-like plate fins is slid over the array of tube lengths 18, one after another, with each opening in each fin 26 receiving a corresponding one of the tube lengths 18, until all the fins 26 are assembled on the plurality of tube lengths 18. The tube lengths 18 are then expanded radially outward from within the tube lengths 18 whereby the outer wall of each of the tube lengths 18 is brought into a forced fit contact with each of the collar portions 28 surrounding the openings in each of the fins 26. When the array of fins 26, commonly referred to as the fin pack, is assembled onto the tube lengths 18, the fin pack extends between the spaced tube sheets 22 and 24 and over substantially the full length of the tube lengths 18. The spacing between the fins within the fin pack is generally defined by the fin collar portions 28. The fins 26 may have thermal performance enhancement features such as corrugations, waves, slits, louvers or the like.

[0019] The collar portions 28 have a flare 30 projecting outwardly from a first edge of the fin and a recess 32 provided in the opposite edge of the fin. When the fins 26 are arrayed in face-to-face spaced relationship during the assembly process, the fin collar portions 28 nest with the flare 30 of one fin received in the recess 32 of the adjacent fin. When the tube lengths 18 are expanded radially outward, the fin collar portions 28 are crushed thereby interlocking the flares 30 with the associated recesses 32. As a result, any spaces or gaps that may have existed between adjacent interlocking fins 26 in the assembled fin pack array are eliminated and an integral layer is formed about the outer wall of the tube lengths 18.

[0020] In an aspect of the heat exchanger 10 disclosed herein, the tubes 12, including the hairpin tube sections 14 and return bends 16, the tube sheets 22, 24 and the fins 26 are all made of aluminum alloys. The tubes 12 are made of a first aluminum alloy, the tube sheets 22, 24 are made of a second aluminum alloy, and fins 26 are made of a third aluminum alloy, with the second and third aluminum alloys having a higher galvanic potential relative to the first aluminum alloy.

Thus, the second and third aluminum alloys are galvanically sacrificial to the first aluminum alloy. Therefore, the aluminum alloy tube sheets 22, 24 and the aluminum alloy fins 26 are galvanically sacrificial to the aluminum alloy tubes 12.

[0021] The selection of the tube alloy, that is the first aluminum alloy, and fin alloy, that is the third aluminum alloy, combination is critical to providing adequate long-term corrosion resistance to the aluminum heat exchanger 10. The fin alloy must be galvanically sacrificial to the tube under the environmental conditions of operation. Generally, the galvanic potential difference between the third aluminum alloy, i.e. the fin alloy, and the first aluminum alloy, i.e. the tube alloy, is greater than about 20 millivolts. Additionally the third aluminum alloy, i.e. the fin alloy, should exhibit low corrosion rates under the environmental conditions of operation. Examples of good fin alloy and tube alloy combinations for an evaporator heat exchanger for transport refrigeration applications include: a tube made of AA3003 aluminum alloy with fins made of AA1100 or AA7072 aluminum alloy, a tube made of AA30048 aluminum alloy and a fin made of AA7072 aluminum alloy, and a tube made of AA3102 aluminum alloy and a fin made of AA7072 aluminum alloy. The aluminum alloy specifications are those of the Aluminum Association standards. Using such combinations, the interlocking aluminum fins 26 form a covering layer that is sacrificial to the underlying aluminum hairpin tubes 14 that provides added corrosion resistance in the fin pack area.

[0022] Similarly, the tube sheets 22, 24 should also be sacrificial relative to the hairpin tubes 14 passing therethrough. The second aluminum alloy of which the tube sheets 22, 24 are formed should have a significant galvanic potential difference, generally also greater than about 20 millivolts, relative to the first aluminum alloy of which the hairpin tubes 14 are formed. Examples of good tube alloy and tube sheet alloy combinations for an evaporator heat exchanger for transport refrigeration applications include: tubes made of AA3003 aluminum alloy with tube sheets made of AA.5052 aluminum alloy, tubes made of AA30048 aluminum alloy with tube sheets made of AA7072 aluminum alloy, and tubes made of AA3102 aluminum alloy with tube sheets made of AA7072 aluminum alloy.

[0023] With large thermal gradient in the refrigeration environment and high vibration loads in the transport applications and the lower tensile strength of aluminum relative to copper, tube-to-tube sheet interference can be a problem if adequate clearance is not provided to avoid long-term tube damage due to fretting. Tube-to-tube sheet clearance must be maintained from the thermal stress standpoint but minimized from vibration related considerations. The clearance, T_s , as measured in a radial direction as indicated in FIG. 5, between the openings in the tube sheet 22, 24 through which a round tube 14, having an outer diameter D , passes may be selected such that the dimensionless ratio T_s/D has a value lying in the range of 0.0013 to 0.0363.

[0024] The return bends 16 and the hairpin turns 20 of the hairpin tubes 14 are disposed outside of the fin pack area and therefore these portions of the serpentine tube 12 are not protected by the sacrificial layer provided by the interlocking fins 26. Coating protection may be applied to the return bends 16 and the hairpin turns 20 of the hairpin tubes 14 to provide corrosion resistance for the hairpin turns 20 and return bends 16 equivalent to the heat exchanger fin pack area design life. For example, protective coatings can be applied to the tube sheet ends so as to coat the hairpin turns 20 and the return

bends 16. Acceptable protective coatings include, for example, but are not limited to, clear acrylic based solvent varnish, urethane based varnish, conversion coats, acrylic e-coats, epoxy e-coats, corrosion inhibitive e-coats, polyester powder, powder coats and pre-treated 2-part epoxies can be applied, depending on the level of protection desired.

[0025] If desired, a protective coating may be applied to the entire heat exchanger 10 to provide added corrosion resistance under severe environment exposure conditions that may be encountered in some transport refrigeration applications. Examples of protective coatings that may be applied to the entire heat exchanger 10 include, but are not limited to, trivalent chrome conversion coats, zirconium conversion coats, zinc phosphate coats and iron phosphate coats. Additionally, any of the previously mention coatings for the application to the hairpin turns 20 and return bends 16 may be applied to the entire heat exchanger 10 as a pre-treatment followed by an overcoat application of the aforementioned coats.

[0026] Aluminum round tube and aluminum plate fin heat exchanger coils can replace heat exchanger coils of a similar construction with copper round tubes and aluminum fins while achieving equivalent thermal performance over a wide range of environmental conditions and operating parameters. Aluminum tubes need to have a thicker wall due to the reduced tensile strength of aluminum alloys compared to their copper counterparts. Aluminum tubes used in heat exchanger applications may be internally grooved or otherwise provided with internal fin enhancements such as illustrated in the exemplary embodiment of the tube 14 depicted in FIGS. 4-6.

[0027] Various non-dimensional groups representing enhanced thermal performance internal tube geometry and improved structural rigidity are provided in the table below (see associated FIGS. 4-6 for the individual parameter definitions).

TABLE I

Parameter	Callout per FIGS. 4-6	Range
Tube Wall/Tube OD (structural)	$(p - h)/D$	0.047-0.086
Fin Height/Tube OD (structural & performance)	h/D	0.0042-0.0429
Fin Height/Fin Bas (structural & performance)	h/a	0.115-1.333
Fin Tip & Base/Tube OD (structural)	$(a + k)/D$	0.04-0.08
Fin Base/Fin Spacing (structural & performance)	a/b	0.65-0.90
Fin Base to Tip Difference/Fn Tip (structural & performance)	$a/k - 1$	0.6-2.0
Fin Base to Tip Difference/Fin Height	$(a - k)/h$	0.25-0.35

Additionally, the ratio of the fin perimeter to fin cross section for the internal fin enhancements may have a value in the range of 400 to 650 (as expressed in inch^{-1} dimension). With reference to FIG. 6, the fin perimeter/fin cross section ratio is defined as $(a+k+2*((a-k)/2)^2+h^2)^{0.5}/(h*(a+k)/2)$.

[0028] The terminology used herein is for the purpose of description, not limitation. Specific structural and functional details disclosed herein are not to be interpreted as limiting, but merely as basis for teaching one skilled in the art to employ the present invention. Those skilled in the art will also recognize the equivalents that may be substituted for elements described with reference to the exemplary embodiments disclosed herein without departing from the scope of the present invention.

[0029] While the present invention has been particularly shown and described with reference to the exemplary embodiments as illustrated in the drawing, it will be recognized by those skilled in the art that various modifications may be made without departing from the spirit and scope of the invention. Therefore, it is intended that the present disclosure not be limited to the particular embodiment(s) disclosed as, but that the disclosure will include all embodiments falling within the scope of the appended claims.

We claim:

1. A heat exchanger comprising; at least one tube having a longitudinally extending tube length, the at least one tube made of a first aluminum alloy having a first galvanic potential; and a plurality of heat exchange fins arrayed on the at least one tube, the plurality of heat exchange fins made of a second aluminum alloy, the second aluminum alloy having a second galvanic potential, the second galvanic potential being higher than the first galvanic potential.
2. The heat exchanger as recited in claim 1 wherein the difference in galvanic potential between the second aluminum alloy and the first aluminum alloy is greater than about 20 millivolts.
3. The heat exchanger as recited in claim 1 wherein the first aluminum alloy comprises aluminum alloy AA3003 and the second aluminum alloy comprises an aluminum alloy selected from the group consisting of AA1100 and AA7072.
4. The heat exchanger as recited in claim 1 wherein the first aluminum alloy comprises an aluminum alloy selected from the group consisting of AA30048 and AA3102 and the second aluminum alloy comprises aluminum alloy AA7072.
5. A heat exchanger comprising; at least one serpentine tube having a plurality of longitudinally extending tube lengths; and a plurality of heat exchange fins arrayed on the at least one tube, adjacent fins of the arrayed plurality of heat exchange fins having interlocking collars disposed about and contacting the at least one tube, the interlocking collars collectively forming a protective layer about the at least one tube.
6. The heat exchanger as recited in claim 5 wherein the protective layer about the at least one tube comprises a galvanically sacrificial layer relative to the at least one tube.
7. The heat exchanger as recited in claim 5 wherein the at least one tube comprises a tube made of a first aluminum alloy having a first galvanic potential; and the plurality of heat exchange fins comprise fins made of a second aluminum alloy, the second aluminum alloy having a second galvanic potential, the second galvanic potential being higher than the first galvanic potential.
8. The heat exchanger as recited in claim 5 wherein the at least one serpentine tube comprises a plurality of hairpin tubes supported between spaced tube sheets, each hairpin tube having a pair of longitudinally extending tube lengths and a hairpin turn, the plurality of hairpin tubes fluidly interconnected by a plurality of return bends.
9. The heat exchanger as recited in claim 8 wherein each tube sheet comprises a tube sheet made of a third aluminum alloy, the third aluminum alloy having a third galvanic potential, the third galvanic potential being higher than the first galvanic potential.
10. The heat exchanger as recited in claim 9 wherein the first aluminum alloy comprises aluminum alloy AA3003 and the third aluminum alloy comprises aluminum alloy AA5052.

11. The heat exchanger as recited in claim 1 wherein the first aluminum alloy comprises an aluminum alloy selected from the group consisting of AA30048 and AA3102 and the third aluminum alloy comprises aluminum alloy AA7072.

12. The heat exchanger as recited in claim 8 wherein the hairpin turns and the return bends are coated with a protective coating for enhancing corrosion resistance.

13. The heat exchanger as recited in claim 12 wherein the protective coating comprises a coating for enhancing corrosion resistance selected from the group including clear acrylic based solvent varnish, urethane based varnish, conversion coats, acrylic e-coats, epoxy e-coats, corrosion inhibitive e-coats, polyester powder, powder coats and pre-treated 2-part epoxies.

14. The heat exchanger as recited in 8 wherein the heat exchanger is coated with a protective coating for further enhancing corrosion resistance.

15. The heat exchanger as recited in claim 14 wherein the protective coating comprises a coating for enhancing corrosion resistance selected from the group including trivalent chrome conversion coats, zirconium conversion coats, zinc phosphate coats and iron phosphate coats.

16. A heat exchanger for use as an evaporator coil in connection with a transport refrigeration system, comprising:

- first and second longitudinally spaced tube sheets;
- a plurality of aluminum alloy hairpin tubes supported between the spaced tube sheets, each hairpin tube having a pair of longitudinally extending tube lengths and a hairpin turn, the plurality of hairpin tubes fluidly interconnected by a plurality of return bends; and
- a plurality of heat exchange fins arrayed on the longitudinally extending tube lengths of the plurality of hairpin tubes, adjacent fins of the arrayed plurality of heat exchange fins having interlocking collars disposed

about and contacting the at least one tube, the interlocking collars collectively forming a protective layer about the at least one tube; the tube sheets the plurality of fins being galvanically sacrificial with respect to the hairpin tubes.

17. The heat exchanger as recited in claim 16 wherein the plurality of hairpin tubes are made of a first aluminum alloy having a first galvanic potential, the plurality of fins are made of a second aluminum alloy having a second galvanic potential, and the tube sheets are made of a third aluminum alloy having a third galvanic potential, each of the second and third galvanic potentials being greater than the first galvanic potential.

18. The heat exchanger as recited in claim 17 wherein the second aluminum alloy and the third aluminum alloy comprise the same aluminum alloy.

19. The heat exchanger as recited in claim 8 wherein each tube sheet has a plurality of tube holes therein, each tube hole receiving a tube length of a respective one of the plurality of hairpin tubes, each tube length having an outside diameter, D, and each hole having a clearance, Ts, relative to the tube length, wherein the ratio Ts/D has a value in the range of 0.0013 to 0.0363.

20. The heat exchanger as recited in claim 1 wherein the at least one tube comprises a tube having internal fins having a fin perimeter and a fin cross-section, the ratio of the fin perimeter to the fin cross-section having a value in the range of 400 to 650, as expressed in inch^{-1} dimension.

21. The heat exchanger as recited in claim 1 wherein the at least one tube comprises a tube having at least one parameter selected from the group of parameters presented in Table I having value in the corresponding range specified therefor in Table I.

* * * * *