



(11) **EP 4 325 003 A3**

(12) **EUROPEAN PATENT APPLICATION**

(88) Date of publication A3:
24.07.2024 Bulletin 2024/30

(51) International Patent Classification (IPC):
E04B 1/24^(2006.01) B23K 101/28^(2006.01)

(43) Date of publication A2:
21.02.2024 Bulletin 2024/08

(52) Cooperative Patent Classification (CPC):
**E04B 1/2403; E04B 2001/2406; E04B 2001/2415;
E04B 2001/2442; E04B 2001/2448;
E04B 2001/2457**

(21) Application number: **23220599.7**

(22) Date of filing: **07.02.2019**

(84) Designated Contracting States:
**AL AT BE BG CH CY CZ DE DK EE ES FI FR GR
HR HU IE IS IT LI LT LU LV MC MK MT NL NO PL
PT RO RS SE SI SK SM TR**

- **MAREK, Kevin**
Hayward, CA 94542 (US)
- **BELLMAN, Eric**
Hayward, CA 94541 (US)
- **SIMMONS, Maxwell C.**
Hayward, CA 94542 (US)
- **SIMMONS, Robert J.**
Hayward, CA 94542 (US)
- **HOOD, Brian**
San Francisco, CA 94116 (US)

(30) Priority: **09.02.2018 US 201862628807 P**

(62) Document number(s) of the earlier application(s) in accordance with Art. 76 EPC:
19750914.4 / 3 749 814

(71) Applicant: **Conxtech, Inc.**
Pleasanton, CA 94566 (US)

(74) Representative: **Hoefer & Partner Patentanwälte mbB**
Pilgersheimer Straße 20
81543 München (DE)

(72) Inventors:
• **BOYD, John S.**
Tiburon, CA 94920 (US)

(54) **FULL MOMENT CONNECTION COLLAR SYSTEMS**

(57) A full-moment column collar is disclosed, including four collar flange components and four collar corner components. Each collar flange component includes an upper transverse element and a lower transverse element, connected by a bridging member. Each collar corner component includes first and second expanses defining a corner and a standoff portion extending from the corner, the standoff portion having a distal T-shaped structure. Each collar corner component is configured to connect two adjacent collar flange components, and each collar corner component has a multi-axis alignment structure extending from a bottom end portion for vertically positioning a lower transverse element of a respective collar flange component.

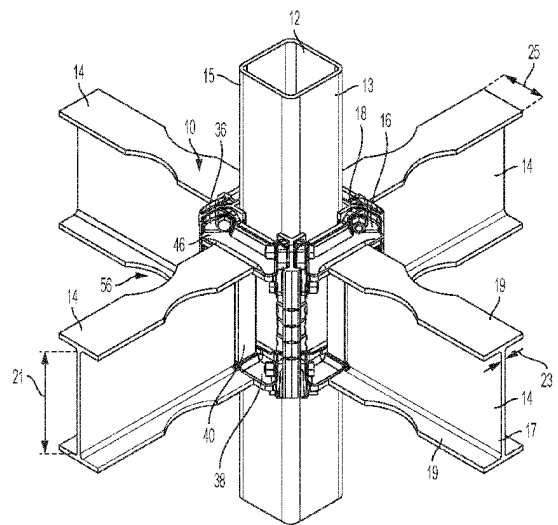

FIG. 1

EP 4 325 003 A3



EUROPEAN SEARCH REPORT

Application Number
EP 23 22 0599

5

10

15

20

25

30

35

40

45

50

55

DOCUMENTS CONSIDERED TO BE RELEVANT			
Category	Citation of document with indication, where appropriate, of relevant passages	Relevant to claim	CLASSIFICATION OF THE APPLICATION (IPC)
X	JP 2017 036654 A (NIPPON STEEL & SUMIKIN METAL PRODUCTS CO LTD; HINODE LTD) 16 February 2017 (2017-02-16) * Translation; paragraph [0018] - paragraph [0090]; figures *	1-12, 14, 15	INV. E04B1/24 ADD. B23K101/28
X	US 7 941 985 B2 (CONXTECH INC [US]) 17 May 2011 (2011-05-17) * column 2, line 24 - column 9, line 6; figures *	1, 13	
			TECHNICAL FIELDS SEARCHED (IPC)
			B23K E04B
The present search report has been drawn up for all claims			
Place of search The Hague		Date of completion of the search 11 June 2024	Examiner López-García, G
CATEGORY OF CITED DOCUMENTS X : particularly relevant if taken alone Y : particularly relevant if combined with another document of the same category A : technological background O : non-written disclosure P : intermediate document		T : theory or principle underlying the invention E : earlier patent document, but published on, or after the filing date D : document cited in the application L : document cited for other reasons & : member of the same patent family, corresponding document	

1
EPO FORM 1503 03:82 (P04C01)

ANNEX TO THE EUROPEAN SEARCH REPORT
ON EUROPEAN PATENT APPLICATION NO.

EP 23 22 0599

5 This annex lists the patent family members relating to the patent documents cited in the above-mentioned European search report.
The members are as contained in the European Patent Office EDP file on
The European Patent Office is in no way liable for these particulars which are merely given for the purpose of information.

11-06-2024

Patent document cited in search report	Publication date	Patent family member(s)	Publication date
JP 2017036654 A	16-02-2017	JP 2017036653 A	16-02-2017
		JP 2017036654 A	16-02-2017
		JP WO2017026113 A1	30-08-2018
		US 2018223521 A1	09-08-2018
		WO 2017026113 A1	16-02-2017

US 7941985 B2	17-05-2011	AU 2008260527 A1	11-12-2008
		BR PI0812350 A2	10-02-2015
		CA 2685181 A1	11-12-2008
		CN 101680227 A	24-03-2010
		EP 2148963 A1	03-02-2010
		EP 3162976 A1	03-05-2017
		ES 2608410 T3	10-04-2017
		ES 2822900 T3	05-05-2021
		HK 1139718 A1	24-09-2010
		JP 5175343 B2	03-04-2013
		JP 2010529331 A	26-08-2010
		KR 20100007872 A	22-01-2010
		US 2008295443 A1	04-12-2008
		WO 2008150433 A1	11-12-2008
