



US 20100324496A1

(19) **United States**

(12) **Patent Application Publication**
PLUMPTRE et al.

(10) **Pub. No.: US 2010/0324496 A1**

(43) **Pub. Date: Dec. 23, 2010**

(54) **DOSE SETTING MECHANISM FOR PRIMING
A DRUG DELIVERY DEVICE**

Related U.S. Application Data

(60) Provisional application No. 61/182,828, filed on Jun. 1, 2009.

(75) Inventors: **David Aubrey PLUMPTRE**,
Droitwich Spa (GB); **James
Alexander DAVIES**, Leamington
Spa (GB); **Christopher John
JONES**, Broadway (GB); **Robert
Frederick VEASEY**, Lillington
(GB)

(30) **Foreign Application Priority Data**

Jul. 10, 2009 (EP) 09009052.3

Publication Classification

(51) **Int. Cl.**
A61M 5/31 (2006.01)

(52) **U.S. Cl.** 604/207

Correspondence Address:
ANDREA Q. RYAN
SANOFI-AVENTIS U.S. LLC
1041 ROUTE 202-206, MAIL CODE: D303A
BRIDGEWATER, NJ 08807 (US)

(57) **ABSTRACT**

A method and system for providing a drug delivery device. The drug delivery device comprises a dose setting mechanism comprising a spindle and a cartridge holder coupled to the dose setting mechanism. The cartridge holder comprising a cartridge having a movable bung at one end of the cartridge. The cartridge holder must be rotated before a dose may set with the dose setting mechanism.

(73) Assignee: **SANOFI-AVENTIS
DEUTSCHLAND GMBH**,
Frankfurt am Main (DE)

(21) Appl. No.: **12/788,683**

(22) Filed: **May 27, 2010**

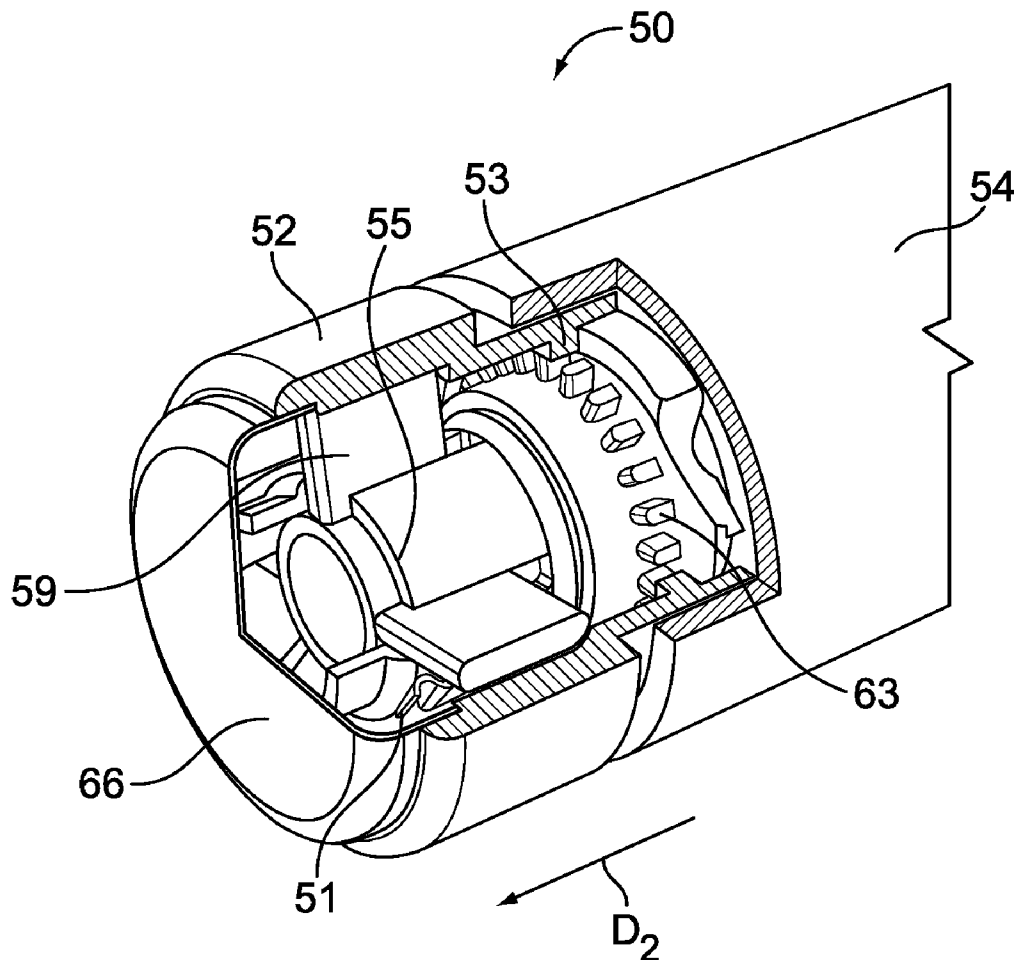

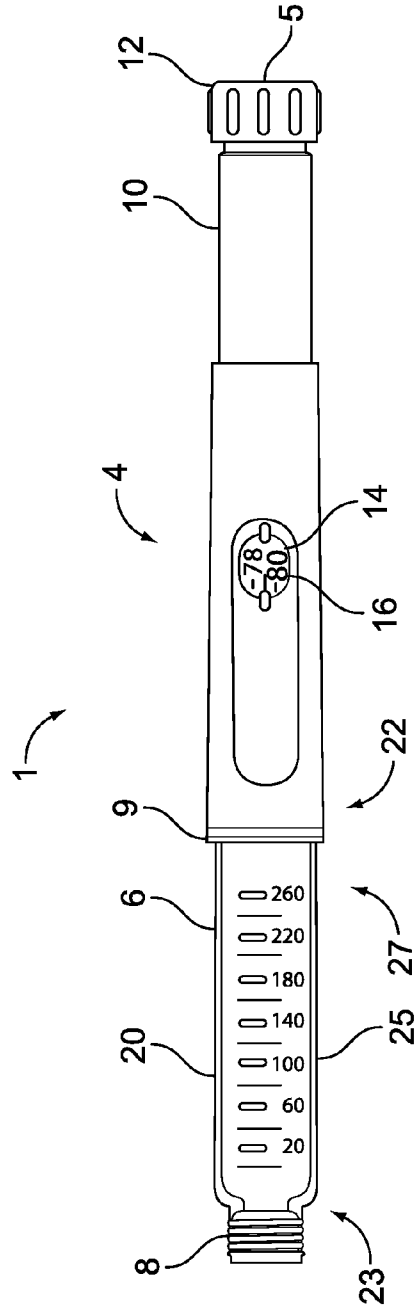
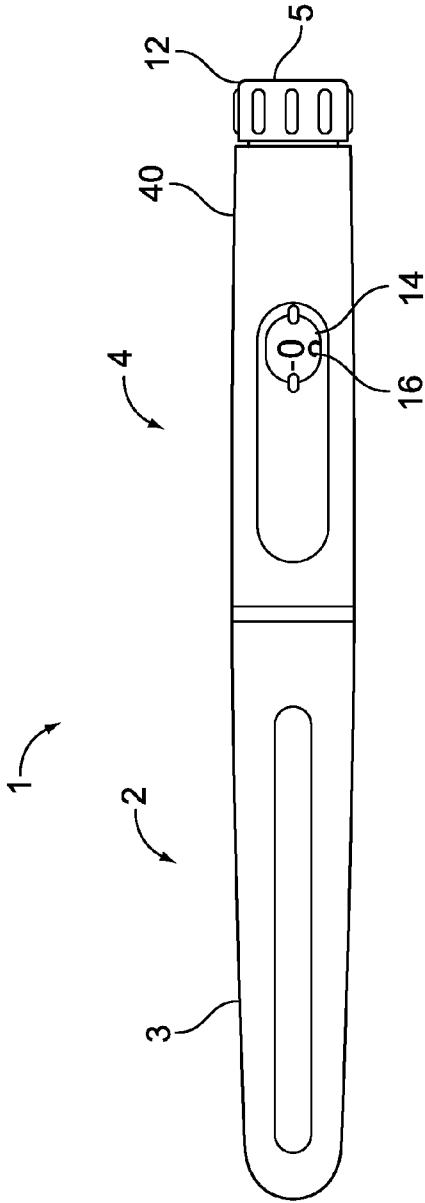

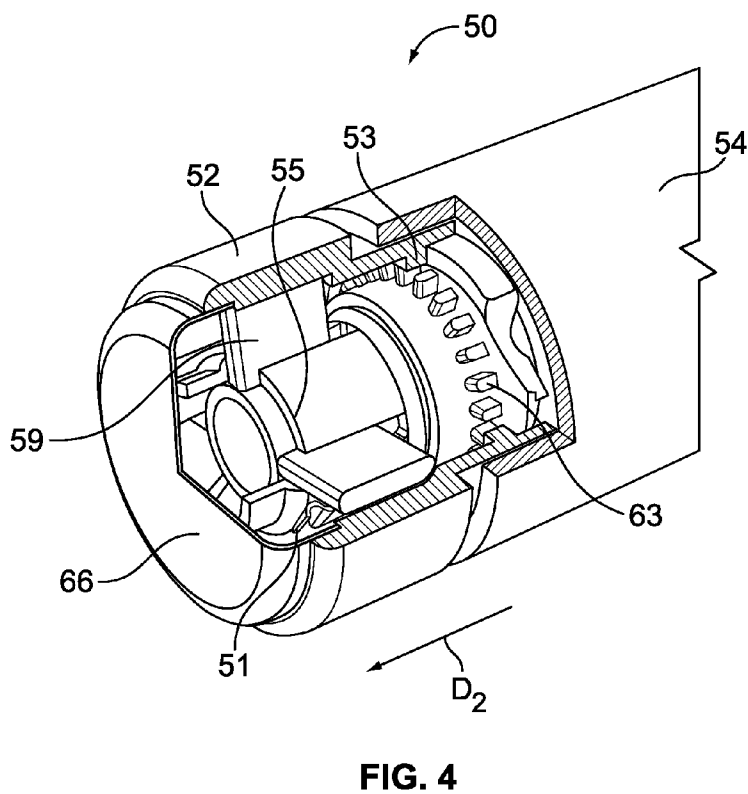
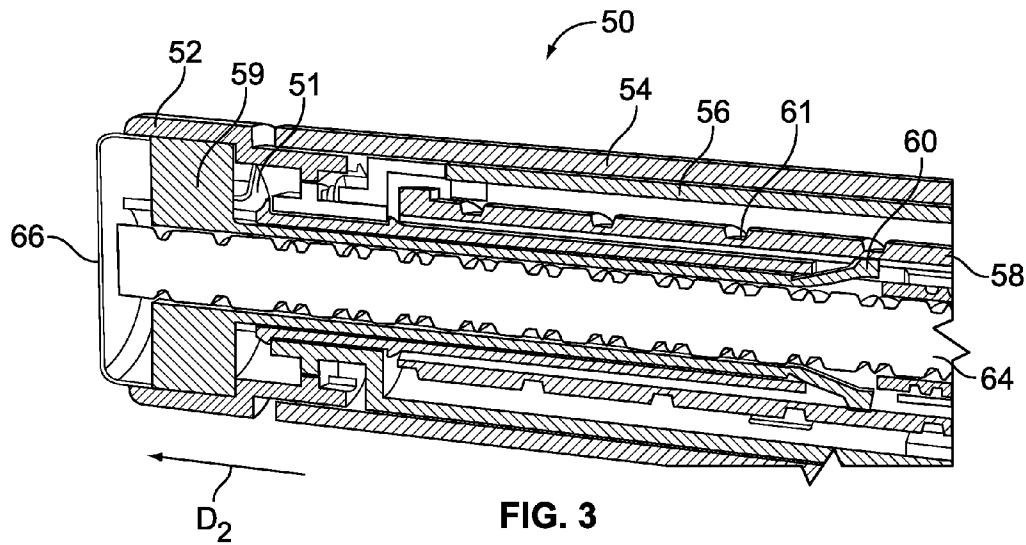

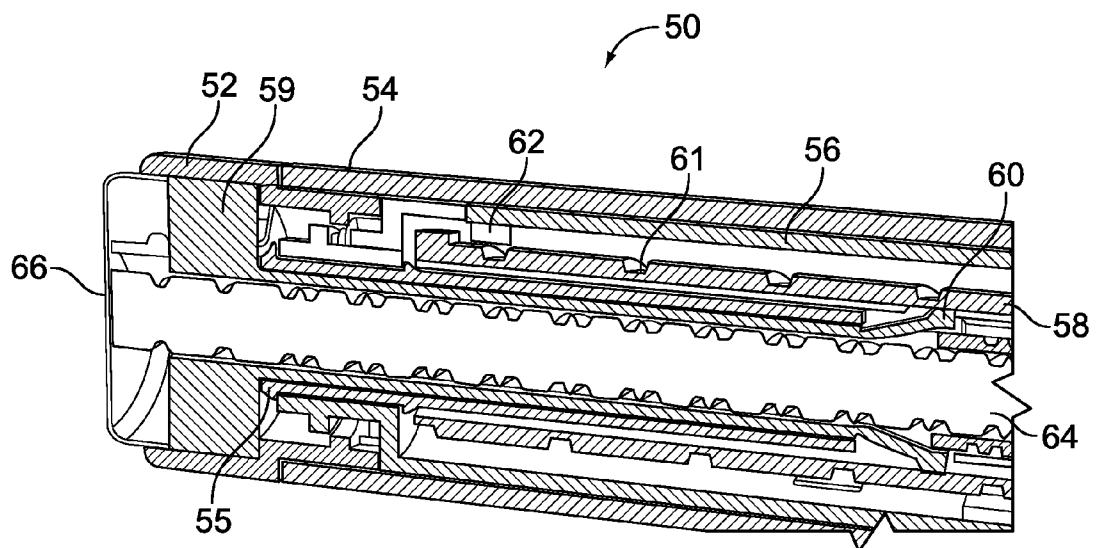

FIG. 5

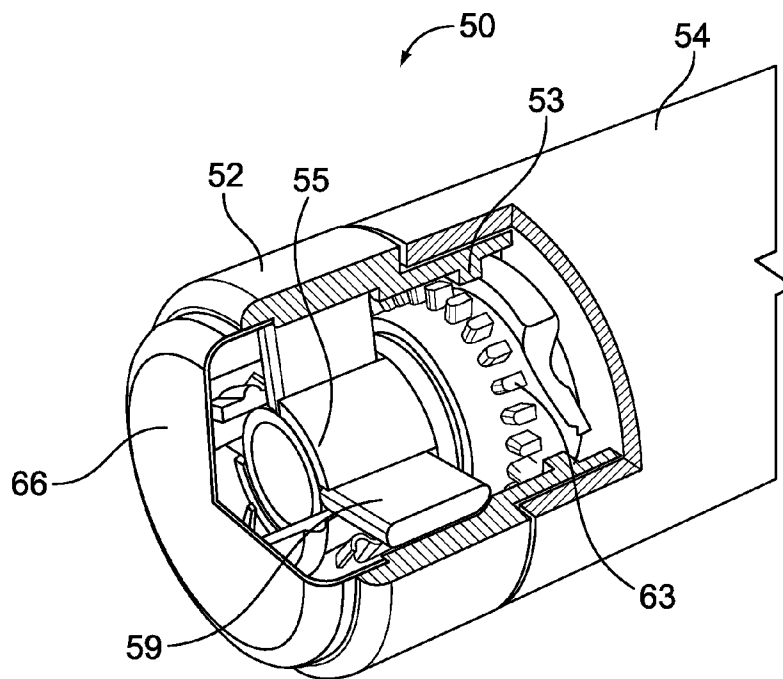
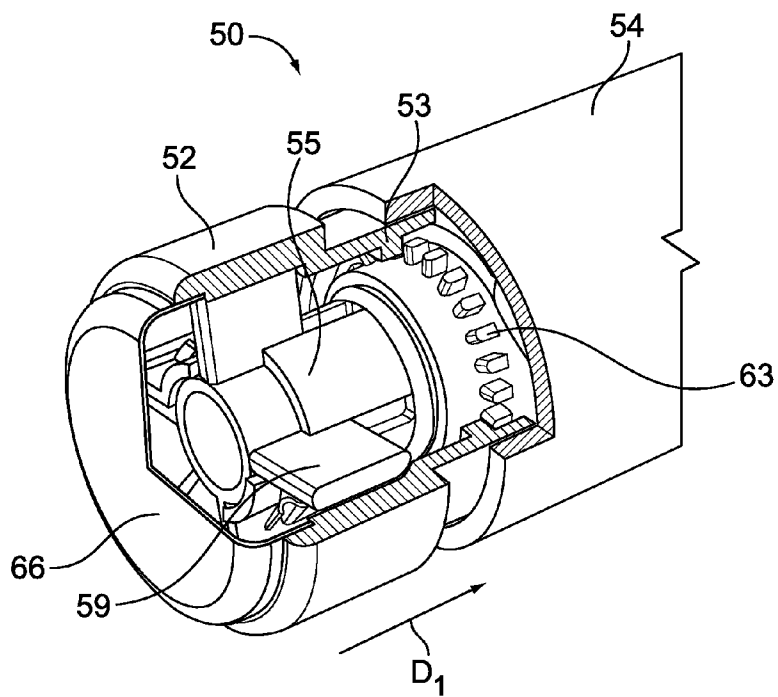
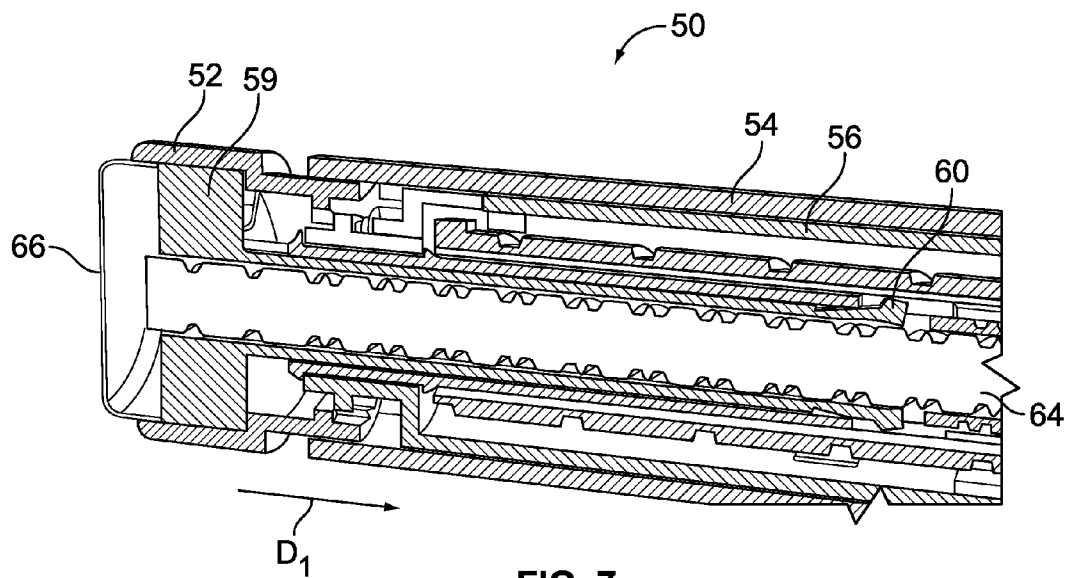

FIG. 6



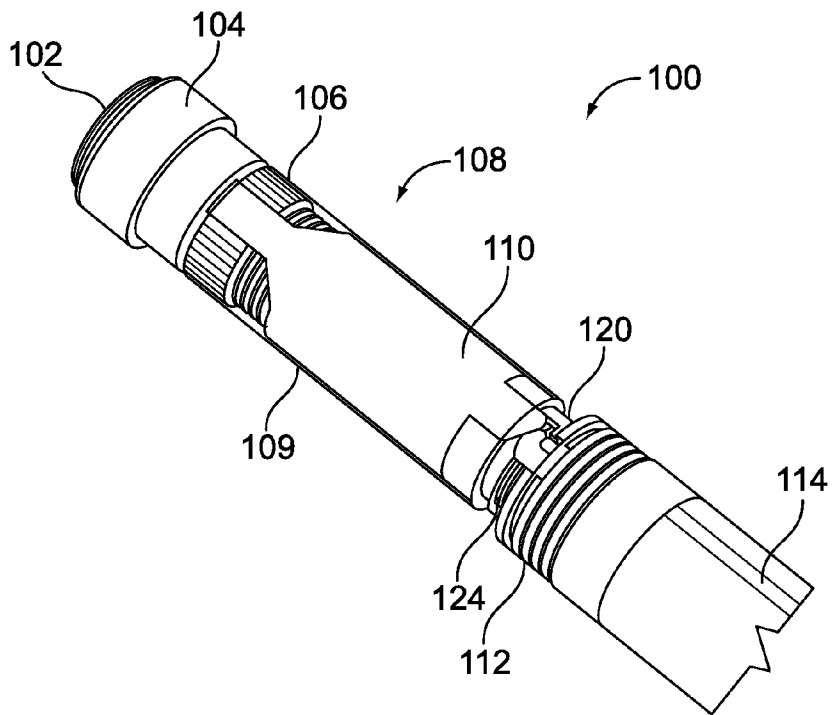

FIG. 9

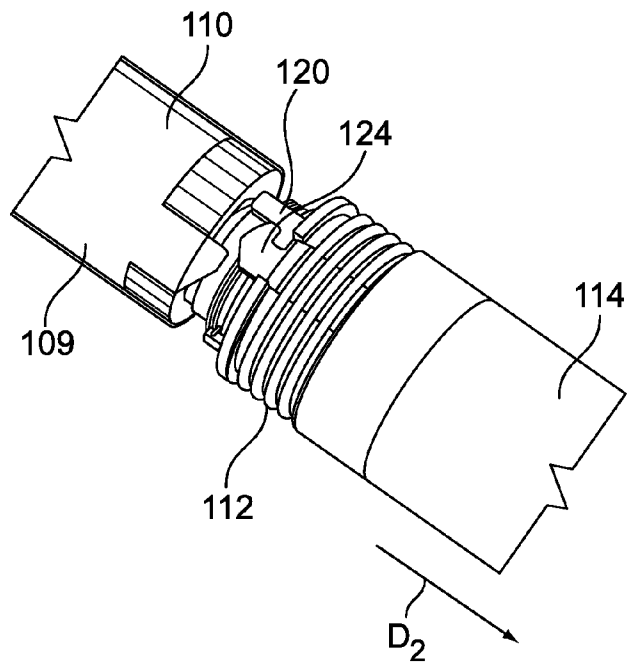

FIG. 10

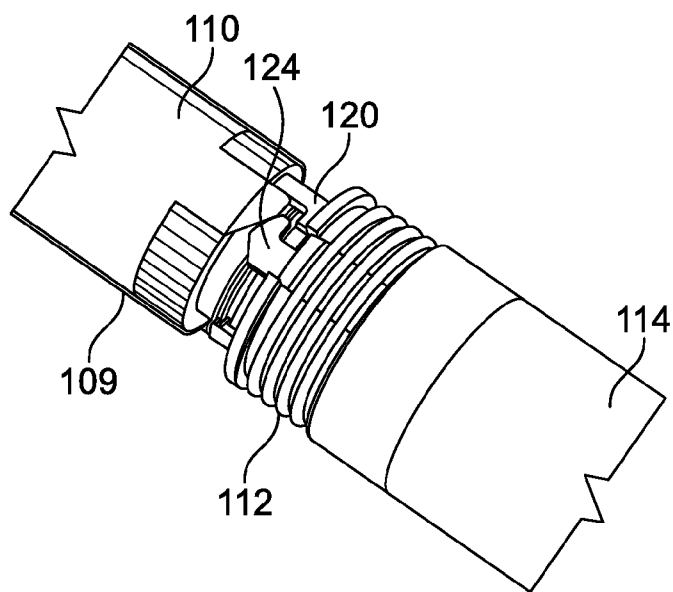

FIG. 11

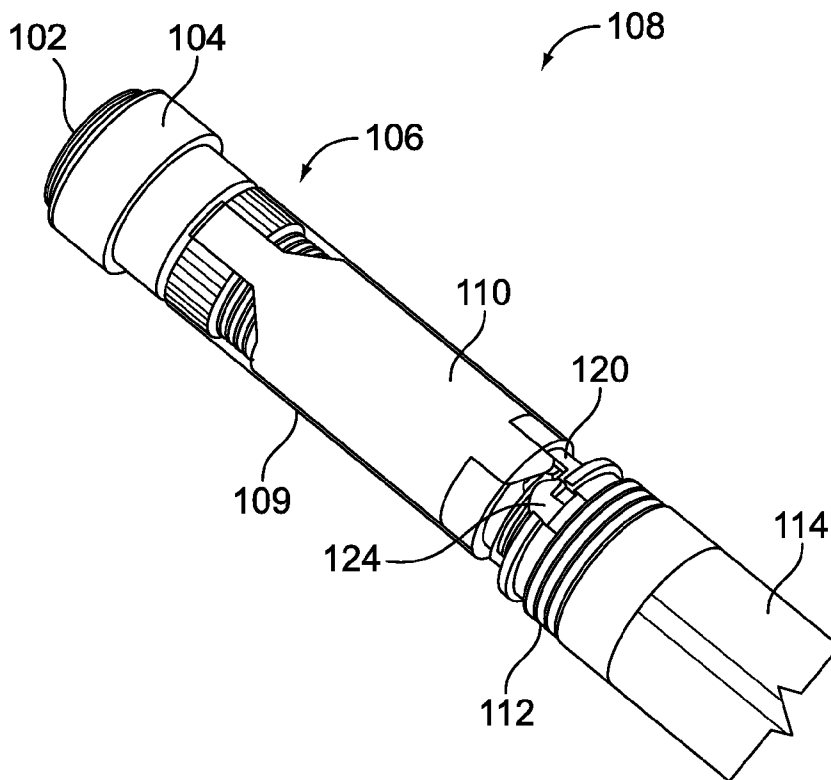

FIG. 12

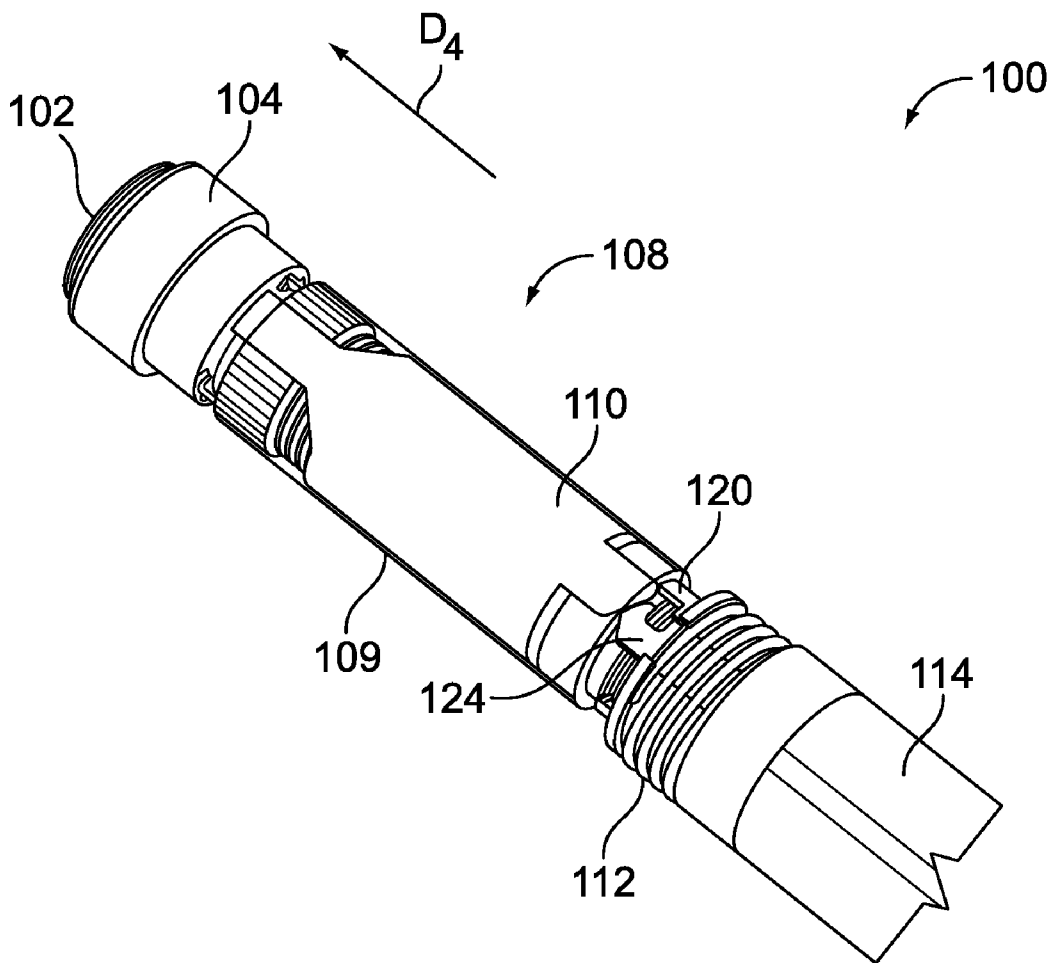

FIG. 13

DOSE SETTING MECHANISM FOR PRIMING A DRUG DELIVERY DEVICE

BACKGROUND

[0001] 1. Field of the Present Patent Application

[0002] The present patent application is generally directed to drug delivery devices. More particularly, the present patent application is generally directed to drug delivery devices, such as pen type drug delivery devices. Such devices provide for self administration of medicinal product from a multi-dose cartridge and permit a user to set the delivery dose. The present application may find application in both resettable (i.e., reusable) and non-resettable (i.e., non-reusable) type drug delivery devices. However, aspects of the invention may be equally applicable in other scenarios as well.

[0003] 2. Background

[0004] Pen type drug delivery devices have application where regular injection by persons without formal medical training occurs. This is increasingly common among patients having diabetes where self-treatment enables such patients to conduct effective management of their disease.

[0005] In certain types of medication delivery devices, such as pen type devices, cartridges of medication are used. These cartridges are housed in a cartridge holder or cartridge housing. Such cartridges include a bung or stopper at one end. At the other end of the cartridge, the cartridge may comprise a pierceable seal. To dispense a dose of medication from such a cartridge, the medication delivery device has a dose setting mechanism that uses a spindle to move in a distal direction towards the cartridge and to press a distal end of the spindle against the bung. This expels a certain set or preselected dose of medication from the cartridge. In order to insure dose accuracy, it is important that the distal end of the spindle remains on the bung of the cartridge before, during and after injection of a dose of medicament.

[0006] One perceived disadvantage of certain known medication delivery devices is that because of the various tolerance differences that may occur during manufacturing (e.g., tolerance differences that may arise during component molding) of the various parts making up the drug delivery device and the desire to not pre-load the bung axially in the assembled device, there may be a gap between the end of the spindle and the cartridge bung after the medication delivery device has been assembled. In other words, when initially assembled, the cartridge (and hence cartridge bung) may not be in contact with the distal end of the spindle. Therefore, if a user using the drug delivery device for the first time dials a dose, the actual dose received may be equal to the dialed dose less the initial gap between the distal end of the spindle and cartridge bung. The air gap between the cartridge bung and distal end of the spindle may be equivalent to a dose that causes the received dose that is outside preferred dose accuracy limits. For example, this air gap may be equivalent to the loss of between 0 and 10 units (i.e., 0-0.14 milliliters) of drug product on the first dose.

[0007] There is, therefore, a general need to take these perceived issues into consideration when designing either resettable or non-resettable drug delivery devices, such as pen type drug delivery devices.

SUMMARY

[0008] According to an exemplary arrangement, a drug delivery device comprises a dose setting mechanism compris-

ing a spindle. A cartridge holder is coupled to the dose setting mechanism. The cartridge holder comprises a cartridge having a movable bung at one end of the cartridge. The cartridge holder is rotated before a dose may set with the dose setting mechanism.

[0009] According to another arrangement, a priming mechanism for a drug delivery device comprises a dose setting mechanism. The dose setting mechanism comprises a spindle and a dose dial sleeve. A cartridge holder comprises a cartridge comprising a movable bung and a pierceable seal. A coupling part connects the cartridge holder to the dose dial sleeve. A spindle nut, rotationally coupled to the coupling part, couples the cartridge holder to the spindle. When the cartridge holder is rotated with respect to the dose setting mechanism, the spindle nut is rotated and the coupling part moves the spindle into an abutting engagement with the bung.

[0010] These as well as other advantages of various aspects of the present invention will become apparent to those of ordinary skill in the art by reading the following detailed description, with appropriate reference to the accompanying drawings.

BRIEF DESCRIPTION OF THE DRAWINGS

[0011] Exemplary embodiments are described herein with reference to the drawings, in which:

[0012] FIG. 1 illustrates an arrangement of a drug delivery device in accordance with the one aspect of the present invention;

[0013] FIG. 2 illustrates the drug delivery device of FIG. 1 with a cap removed and with a dose having been selected;

[0014] FIG. 3 illustrates a close up view of a drug delivery device before a priming step, such as the drug delivery device illustrated in FIG. 1;

[0015] FIG. 4 illustrates a close up view of the drug delivery device illustrated in FIG. 3 after completion of a priming step;

[0016] FIG. 5 illustrates a close up view of a connection between a dose setting mechanism and cartridge housing of a drug delivery device in a non-priming state, such as drug delivery device illustrated in FIGS. 3 and 4;

[0017] FIG. 6 illustrates a close up view of the connection between the dose setting mechanism and the cartridge illustrated in FIG. 5, in a priming state;

[0018] FIG. 7 illustrates a close up view of a proximal end of the cartridge housing illustrated in FIGS. 5 and 6, including a coupling part

[0019] FIG. 8 illustrates how the coupling part illustrated in FIG. 7 may be used to engage a dose dial sleeve of a dose setting mechanism, such as the dose setting mechanism illustrated in FIGS. 5 and 6;

[0020] FIG. 9 illustrates the coupling part illustrated in FIG. 8 in a non-primed state;

[0021] FIG. 10 illustrates the coupling part illustrated in FIG. 9 in a primed state;

[0022] FIG. 11 illustrates a close up view of the stop faces provided along the distal end of the dose dial sleeve illustrated in FIG. 10

[0023] FIG. 12 illustrates a spindle nut that may be used to couple the coupling part to a dose setting member and to a cartridge housing; and

[0024] FIG. 13 illustrates the spindle nut coupled to the coupling part and dose dial sleeve of a dose setting mechanism.

DETAILED DESCRIPTION

[0025] Referring to FIG. 1, there is shown a drug delivery device 1 in accordance with an exemplary arrangement. The drug delivery device 1 comprises a housing having a first cartridge retaining part 2, and a dose setting mechanism 4. The drug delivery device may be a resettable drug delivery device (i.e., a reusable device) or alternatively a non-resettable drug delivery device (i.e., a non-reusable device). A first end of the cartridge retaining part 2 and a second end of the dose setting mechanism 4 are secured together by connecting features. For non-resettable devices, these connecting features would be permanent and non-reversible. For resettable devices, these connecting features would be releasable.

[0026] In this illustrated arrangement, the cartridge housing 2 is secured within the second end of the dose setting mechanism 4. A removable cap 3 is releasably retained over a second end or distal end of a cartridge retaining part or cartridge housing. The dose setting mechanism 4 comprises a dose dial grip 12 and a window or lens 14. A dose scale arrangement 16 is viewable through the window or lens 14. To set a dose of medication contained within the drug delivery device 1, a user rotates the dose dial grip 12 such that a dialed dose will become viewable in the window or lens 14 by way of the dose scale arrangement 16.

[0027] FIG. 2 illustrates the medical delivery device 1 of FIG. 1 with the cover 3 removed from a distal end 19 of the medical delivery device 1. This removal exposes the cartridge housing 6. As illustrated, a cartridge 25 from which a number of doses of a medicinal product may be dispensed, is provided in the cartridge housing 6.

[0028] Preferably, the cartridge 25 contains a type of medicament that can be administered relatively often, such as once or more times a day. One such medicament is either long acting or short acting insulin or an insulin analog. The cartridge 25 comprises a bung or stopper (not illustrated in FIG. 2) that is retained near a second end or a proximal end 33 of the cartridge 25. The medical delivery device also comprises a driver having a spindle (not illustrated in FIG. 2). As discussed above, before the device is primed, there may or may not be a gap between the end of the spindle and the cartridge bung.

[0029] The cartridge housing 6 has a distal end 23 and a proximal end 27. Preferably, the cartridge distal end 23 of the cartridge housing 6 comprises a groove 8 for attaching a removable needle assembly. However, other needle assembly connection mechanisms could also be used. If the drug delivery device 1 comprises a resettable device, the cartridge proximal end 27 is removably connected to the dose setting mechanism 4. In one preferred embodiment, cartridge housing proximal end 27 is removably connected to the dose setting mechanism 4 via a bayonet connection.

[0030] However, as those of ordinary skill in the art will recognize, other types of removable connection methods such as threads, partial threads, ramps and detents, snap locks, snap fits, and luer locks may also be used.

[0031] As previously mentioned, the dose setting mechanism 4 of the drug delivery device illustrated in FIG. 2 may be utilized as a reusable drug delivery device. (i.e., a drug delivery device that can be reset) Where the drug delivery device 1 comprises a reusable drug delivery device, the cartridge 25 is

removable from the cartridge housing 6. The cartridge 25 may be removed from the device 1 without destroying the device 1 by merely having the user disconnect the dose setting mechanism 4 from the cartridge housing 6.

[0032] In use, once the cap 3 is removed, a user can attach a suitable needle assembly to the groove 8 provided at the distal end 23 of the cartridge housing 6. Such needle assembly may be, for example, screwed onto a distal end 23 of the housing 6 or alternatively may be snapped onto this distal end 23. After use, the replaceable cap 3 may be used to re-cover the cartridge housing 6. Preferably, the outer dimensions of the replaceable cap 3 are similar or identical to the outer dimensions of the dose setting mechanism 4 so as to provide an impression of a unitary whole when the replaceable cap 3 is in position covering the cartridge housing 6 when the device is not in use.

[0033] In accordance with an exemplary arrangement, it may be beneficial to force a user to prime the drug delivery device of FIGS. 1 and 2 before the user dials and injects the first dose. In order to achieve this forced priming, as will be discussed in greater detail below, the drug delivery device 1 preferably forces a user to prime the device before they are permitted to select the first dose.

[0034] The process of forcing a user to prime the cartridge before they can select and dispense the first dose reduces a potential risk of injecting the prime dose. The idea of forced priming is particularly advantageous for disposable devices where there is oftentimes a gap between a distal end of the spindle and the cartridge bung before the device is used. This gap is a consequence of the tolerances associated with the assembled parts as well as the desire not to pre-load the bung axially in the assembled device.

[0035] If the device is designed so that this gap between a distal end of the spindle and the bung is removed (i.e., the device primed) before the user is able to dial a dose, then this is advantageous. In one preferred arrangement, the drug delivery device achieves this by the user rotating the cartridge holder relative to the housing in order to both prime the device and also to unlock the number sleeve so the user can subsequently rotate the dose dial sleeve to set the first dose. Preferably, once the device has been primed, the cartridge holder is locked rotationally and therefore cannot be rotated with respect to the dose setting mechanism.

[0036] FIG. 3 illustrates a close up view of a drug delivery device 50 before a priming step, such as the drug delivery device 1 illustrated in FIG. 1. FIG. 4 illustrates a close up view of the drug delivery device 50 illustrated in FIG. 3 after completion of a priming step. As illustrated, the drug delivery device 50 comprises a dose setting mechanism 52 coupled to a cartridge housing 54. Where the drug delivery device 50 comprises a re-settable drug delivery device, this coupling mechanism comprises a releasable coupling mechanism (i.e., a thread, a bayonet lock, a luer lock, a snap fit or snap lock, etc.) Where the drug delivery device 50 comprises a non-resettable drug delivery device (i.e., a disposable drug delivery device), this coupling mechanism comprises a non-reversible coupling mechanism.

[0037] In this preferred arrangement of drug delivery device 50, the dose setting mechanism 52 comprises various markings and indications along an outer surface 53. As can be seen in this arrangement, this marking comprises a marking indicating a locked position (i.e., un-primed state) 58 and a marking indicating an unlocked position (i.e., primed state) 62. In

addition, various intermediate markings 59 are provided between the locked and unlocked position markings 58, 62, respectively.

[0038] In addition, the cartridge housing 54 comprises markings along its outer surface 63 and these markings include a positional indicator (i.e., an arrow) 56 that is used to indicate the relative position of the cartridge housing 54 with respect to the outer surface 53 of the dose setting mechanism 52. In this preferred arrangement, to prime the drug delivery device 50, the cartridge housing 54 is rotated in direction of arrow 60. Preferably, the cartridge housing 54 is rotated in the direction of arrow 60 with respect to the dose setting mechanism 52 so that the arrow 56 moves from the locked marking 58 and then aligns with the unlocked designation 62, as shown in FIG. 4. In this final position, the drug delivery device 50 now resides in a primed state. That is, the spindle contained in the dose setting mechanism 52 now resides adjacent or abuts the bung provided in the cartridge of the cartridge housing 54. In addition, in a preferred arrangement, the drug delivery device 50 is also now unlocked so that the dose setting mechanism 52 may now be used to set a dose (as illustrated in FIG. 2). Most preferably, in this final position, the cartridge holder 54 is also rotationally locked and can therefore no longer be rotated with respect to the dose setting mechanism 52. FIG. 5 illustrates a close up view of a connection between a dose setting mechanism and cartridge housing of a drug delivery device 70, such as drug delivery device 50 illustrated in FIGS. 3 and 4. In FIG. 5, the drug delivery device 70 is in a pre-primed state. Therefore, with the drug delivery device illustrated in FIG. 5, a user could not set a dose until the device is primed. As illustrated, the dose setting mechanism 74 is rotationally coupled to the cartridge housing 72. In this arrangement, the cartridge housing 72 comprises a rib 76 that engages with an internally formed cavity on an inner surface of the dose setting mechanism 74. This configuration allows for relative rotational movement only between the dose setting mechanism 74 and the cartridge housing 76 and no axial movement. This rotational relative movement occurs when the cartridge holder 72 is rotated from the locked position (i.e., FIG. 5) to the unlocked position (i.e., FIG. 6).

[0039] FIG. 7 illustrates a close up view of a proximal end 68 of the cartridge housing 72 illustrated in FIGS. 5 and 6. FIG. 7 also illustrates a coupling part 80 that may be used to couple the cartridge housing 72 to a dose setting mechanism, such as the dose setting mechanism 74 illustrated in FIGS. 5 and 6. In this preferred arrangement, this cartridge housing 72 comprises an L shaped cavity 73 provided along a first outer surface 75 of the cartridge housing 72. As described with respect to FIGS. 5 and 6 and as will be described in greater detail below, this cavity 73 is used to engage a portion of a coupling part so as to allow relative rotation between the cartridge holder 72 and the dose setting mechanism.

[0040] In this preferred arrangement, coupling part 80 comprises a thin metal pressing. However, those of ordinary skill will recognize that alternative coupling part arrangements may also be used. In this preferred arrangement, the coupling part 80 comprises a first set of axial projecting members 82a, 82b that project in an axial direction towards the distal end 69 of the cartridge housing 72. These projecting members 82a, 82b rotationally affix or engage a first portion 75 of the cavity 73. In addition, the coupling part 80 rotationally couples to a spindle nut and therefore a spindle of a dose setting mechanism and also acts upon a dose dial sleeve of the dose setting mechanism.

[0041] The coupling part 80 further comprises a second set of axial projecting members 86a, 86b. This second set of projecting members 86a, 86b extend in a proximal direction away from the proximal end 68 of the cartridge housing 72. This second set of projecting members 86a, 86b engage a portion of the dose setting mechanism, specifically an inner housing of the dose setting mechanism. As described below, the coupling part 80 further comprises two inwardly extending arms 84a, 84b that engage a spindle nut of the dose setting mechanism.

[0042] FIG. 8 illustrates how the coupling part 80 illustrated in FIG. 7 may be used to engage an inner housing 92 of a dose setting mechanism, such as the dose setting mechanism illustrated in FIGS. 5 and 6. As illustrated, the inner housing 92 comprises a first and a second flexible locking elements 98a, 98b located near a distal end 93 of the inner housing 92. Also near this distal end 93 is a circular shaped housing portion 94. This housing portion 94 defines a cavity portion 101 having an inner surface and along this inner surface there are two internally radially directed recesses 96a and 96b.

[0043] During assembly, the coupling part 80 will be positioned to slide into the cavity 101 of the housing portion 94 such that the second set of protruding members 86a, 86b of the coupling part 80 slide through recesses 96a, 96b of the housing portion 94, respectively. The second members 86a, 86b will then be positioned to reside over an external surface of the inner housing flexible elements 98a, 98b, respectively. In this position, the drug delivery device will not be primed but rather the dose dial sleeve 103 will be locked out and prevented from rotating. As such, a user of such a drug delivery device will be prevented from selecting a dose, that is, the user will be prevented from rotating the dose dial sleeve 103 before the user has undertaken a drug delivery device priming step.

[0044] FIG. 9 illustrates the coupling part 80 engaged with the distal end 93 of the inner housing 92. As illustrated, the coupling part 80 is in an initial position or in a non-primed state, before device priming occurs. In this initial position, the set of protruding elements 86a, 86b reside over the surface of the flexible elements 96a, and 96b, respectively. Therefore, when a cartridge holder is connected to the housing and is rotated (as illustrated in FIGS. 4 and 5), the coupling part 80 also rotates. As the coupling part 80 is rotated in the direction of arrow D1, the first set of protruding elements 86a, 86b rotate over the flexible locking elements 98a, 98b and end up releasing these flexible locking elements, and therefore stop faces 106a, 106b from the dose dial sleeve. FIG. 10 illustrates the coupling part 80 and inner housing 92 after rotating the coupling part to release the flexible locking elements and thereby completing of the priming step. As illustrated, the coupling part 80 has been rotated to a final or stop position 102 and the coupling part 80 has now been rotated less than 360 degrees so as to push the inner housing flexible elements 98a, 98b radially inward. This releases the inner housing stop faces 106a, 106b, from the dose dial sleeve 103. FIG. 11 illustrates a close up view of the stop faces 106a, 106b provided along the distal end of the inner housing 92. The dose dial sleeve 103 is also illustrated with a scale arrangement 104 provided along an outer surface of this dose dial sleeve 103. The dose dial sleeve 103 has mating stop faces 97a, 97b that engage with stop faces 96a, 96b on the inner housing

[0045] A spindle nut 114 is coupled to the coupling part 80 so that when the coupling part 80 rotates the spindle nut 114

rotates to drive a spindle **124** distally. As illustrated, this spindle nut **114** is circular in shape and comprises a first and a second helical ramp **116a**, **116b**. The spindle nut **114** further comprises a circular cavity having a male groove member **118**. Once assembled, the spindle nut **114** is rotationally coupled to the coupling part **80** so that when a cartridge holder is coupled to a dose setting member and the cartridge holder is rotated, the spindle nut **114** rotates along with the cartridge holder. The first and second helical ramps **116a**, **116b** serve to drive the spindle nut **114** in a distal direction (i.e., towards the injection site) when the cartridge holder is rotated. Where the spindle nut **114** is used in drug delivery device comprising a non-resettable drug delivery device, these helical ramps lock the cartridge holder rotationally at the end of the priming step. However, where the spindle nut is used in a resettable drug delivery device, the helical ramps are detented so as to allow the cartridge housing **72** to be rotated back and removed to enable a new cartridge to be fitted.

[0046] The height of the helical ramps **116a**, **116b** help to offset any slack in the drive mechanism that drives the spindle of the dose setting mechanism forwards to dispense a dose. In this manner, rotating the cartridge holder is generally equivalent to pressing on a dose button of the dose setting mechanism so as to take up slack in the drive mechanism.

[0047] FIG. 13 illustrates the spindle nut **114** coupled to the coupling part **80** and inner housing **92** of a dose setting mechanism. In this illustration, the coupling part **80** is rotated by the cartridge holder (not illustrated). This in turn rotates the spindle nut **114**. As illustrated, this spindle has at least two overlapping grooves. Preferably, one of these grooves **130** is engaged with a portion of the drug deliver device and could be either helical or axially extending along its length.

[0048] Because in one arrangement the spindle **124** is threaded to a portion of the drug delivery device, as the spindle nut **114** rotates, it advances the spindle **124** axially in the distal direction **D2** **128** so as to prime the drug delivery device. The rotation of the cartridge housing, as mentioned, also unlocks the dose dial sleeve **103** to allow a user to now set a first dose of medication for the drug delivery device.

[0049] Exemplary embodiments of the present invention have been described. Those skilled in the art will understand, however, that changes and modifications may be made to these embodiments without departing from the true scope and spirit of the present invention, which is defined by the claims.

1. A drug delivery device, said drug delivery device comprising:

a dose setting mechanism comprising a spindle; and a cartridge holder coupled to said dose setting mechanism, said cartridge holder comprising a cartridge having a movable bung at one end of said cartridge;

wherein said cartridge holder must be rotated before a dose may be set with said dose setting mechanism.

2. The invention of claim 1 wherein said cartridge holder must be rotated with respect to said dose setting mechanism before said dose may be set with said dose setting mechanism.

3. The invention of claim 1 wherein rotation of said cartridge holder primes said drug delivery device.

4. The invention of claim 1 wherein rotation of said cartridge holder moves said spindle into an abutting engagement with said bung of said cartridge.

5. The invention of claim 1 wherein rotation of said cartridge holder enables a dose dial sleeve of said dose setting mechanism to rotate.

6. The invention of claim 5 wherein rotation of said dose dial sleeve allows a user of said dose setting mechanism to set said dose.

7. The invention of claim 1 wherein after said cartridge holder is rotated, said cartridge holder is rotationally locked to said dose setting mechanism.

8. The invention of claim 7 wherein after said cartridge holder is rotated, said cartridge holder is rotationally locked to said dose setting mechanism by way of a one way, non-return detent feature.

9. The invention of claim 1 wherein said cartridge holder provides a visual indication that said cartridge holder must be rotated before said dose may be set by said dose setting mechanism.

10. The invention of claim 1 wherein said drug delivery device is a resettable drug delivery device.

11. The invention of claim 1 wherein said drug delivery device is not a resettable drug delivery device.

12. The invention of claim 1 wherein said cartridge holder must be rotated less than 360 degrees before a dose may be set with said dose setting mechanism.

13. A priming mechanism for a drug delivery device, said priming mechanism comprising:

a dose setting mechanism comprising a spindle; and a dose dial sleeve;

a cartridge holder, said cartridge holder comprising a cartridge, said cartridge comprising a movable bung near a proximal end of said cartridge;

a coupling part connecting said cartridge holder to said dose dial sleeve of said dose setting mechanism, and

a spindle nut rotationally coupled to said coupling part, said spindle nut coupling said cartridge holder to said spindle of said dose setting mechanism;

such that when said cartridge holder is rotated with respect to said dose setting mechanism,

said spindle nut is rotated and moves said spindle into an abutting engagement with said bung.

14. The invention of claim 13 wherein said coupling part unlocks said dose dial sleeve so that said dose dial sleeve may be rotated to set a dose.

15. The invention of claim 13 wherein said coupling part comprises a thin metal pressing.

16. The invention of claim 13 wherein said coupling part comprises a rigid coupling component (Ok).

17. The invention of claim 13 wherein said dose setting mechanism comprises at least one flexible locking element, wherein when said cartridge holder is rotated, said coupling part also rotates to thereby release said flexible locking element and allowing said dose dial sleeve to rotate and allow a user of said medical delivery device to set a dose.

18. The invention of claim 13 wherein said spindle nut further comprises a plurality of helical ramps, said plurality of helical ramps driving said spindle nut in a distal direction when said cartridge holder is rotated so that said spindle abuts a first surface of said bung.

* * * * *