



(19) **United States**

(12) **Patent Application Publication**  
Sweetland

(10) **Pub. No.: US 2013/0108834 A1**

(43) **Pub. Date: May 2, 2013**

(54) **METHODS AND SYSTEMS FOR THE PREPARATION OF MOLDED PLASTIC ARTICLES HAVING A STRUCTURAL BARRIER LAYER**

(52) **U.S. Cl.**  
CPC ..... *B29C 45/164* (2013.01)  
USPC ..... **428/162**; 264/241; 425/130

(75) Inventor: **Matthew Sweetland**, Bedford, MA (US)

(73) Assignee: **KORTEC, INC.**, Rowley, MA (US)

(21) Appl. No.: **13/593,489**

(22) Filed: **Aug. 23, 2012**

**Related U.S. Application Data**

(60) Provisional application No. 61/526,495, filed on Aug. 23, 2011.

**Publication Classification**

(51) **Int. Cl.**  
*B29C 45/16* (2006.01)

(57) **ABSTRACT**

Disclosed herein are methods and systems for the preparation of a co-injection molded multilayer plastic article. Some methods include co-extruding a combined polymeric stream having an interior core stream encased by an inner stream and an outer stream. A volumetric ratio of the inner stream to outer stream is adjusted during injection of the combined stream into the a mold cavity to alter a streamline along which the interior core stream flows thereby forming cohesion member that structurally interlocks the interior layer with the inner layer, with the outer layer or with both. Some embodiments reduce or eliminate a need for addition of an adhesive in the composite stream to prevent delamination of layers of the resulting multilayer plastic article. In some embodiments, cohesion members may be employed to produce a desired cosmetic effect in a resulting article.

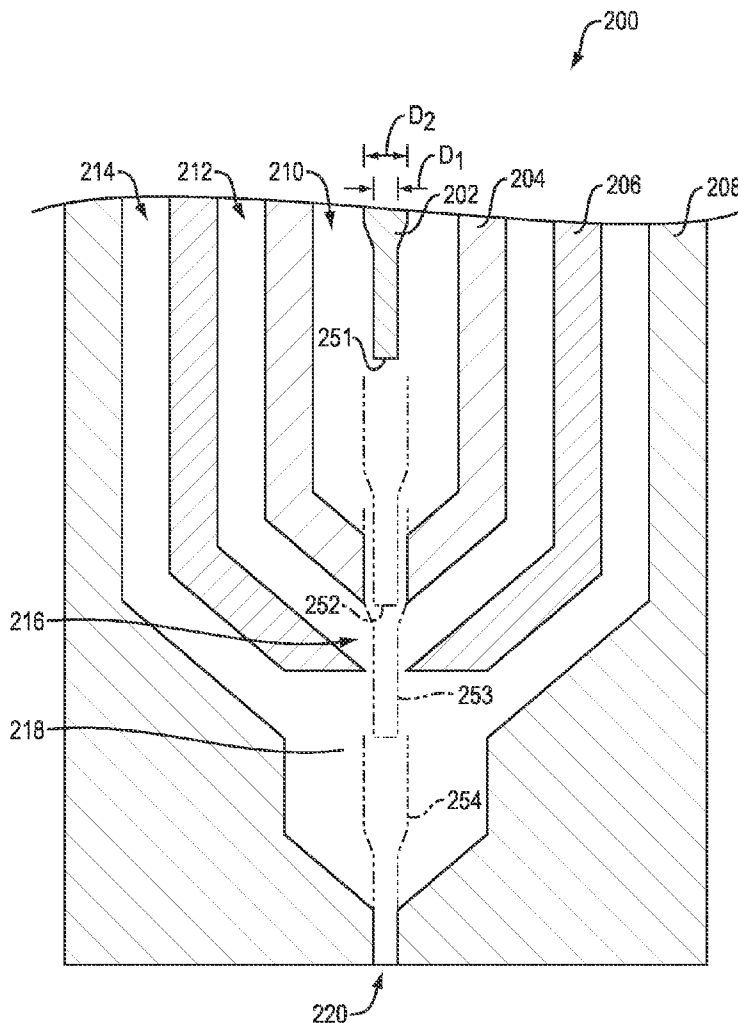

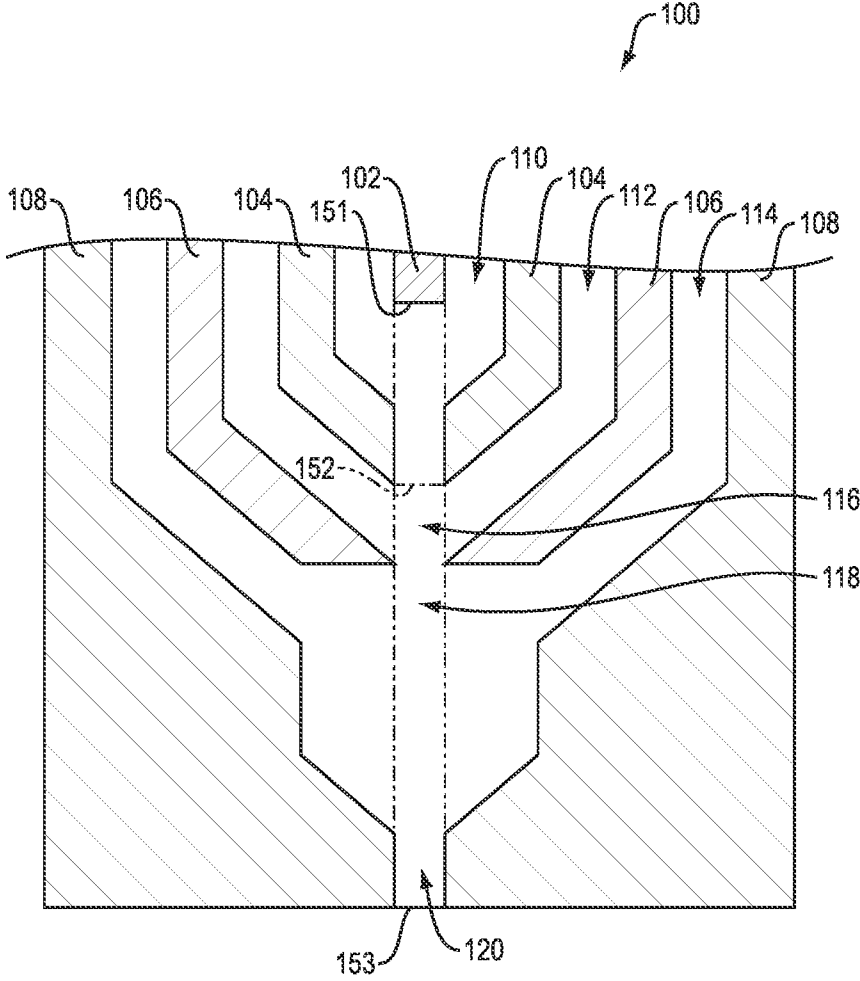

FIG. 1

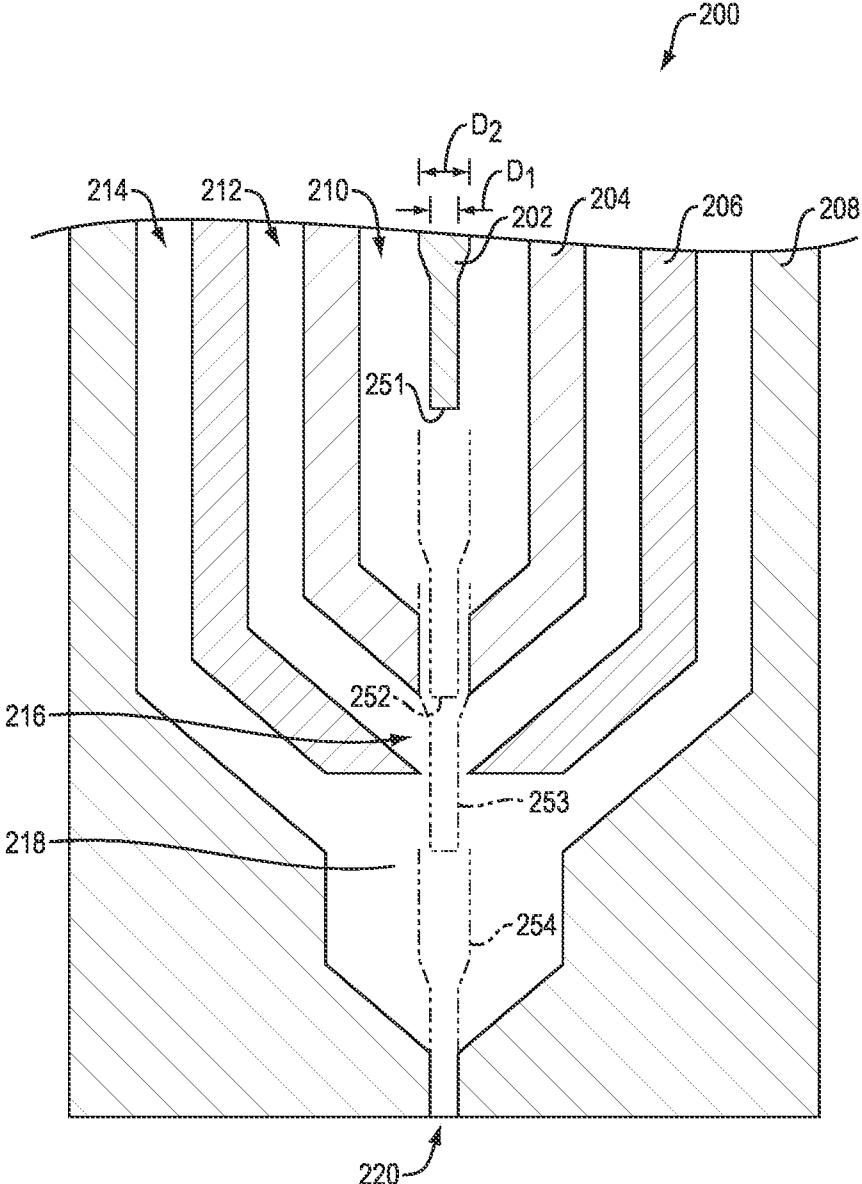

FIG. 2

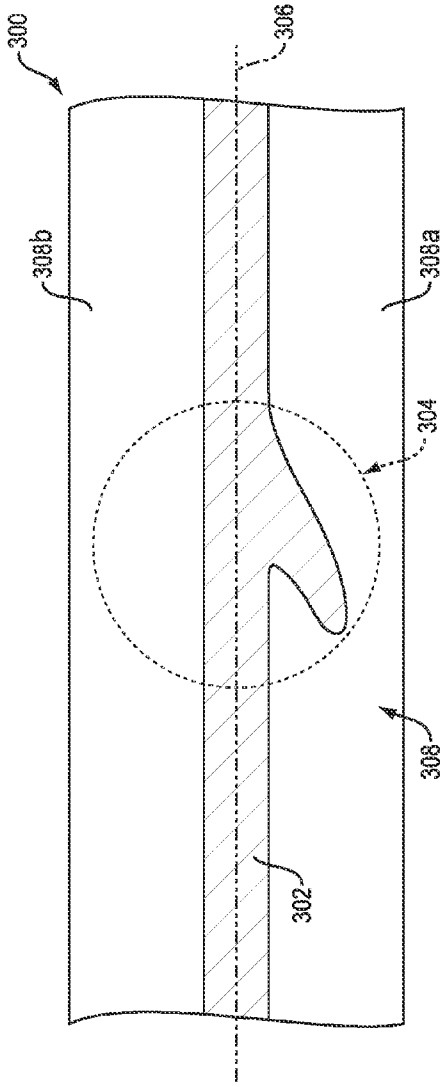

FIG. 3

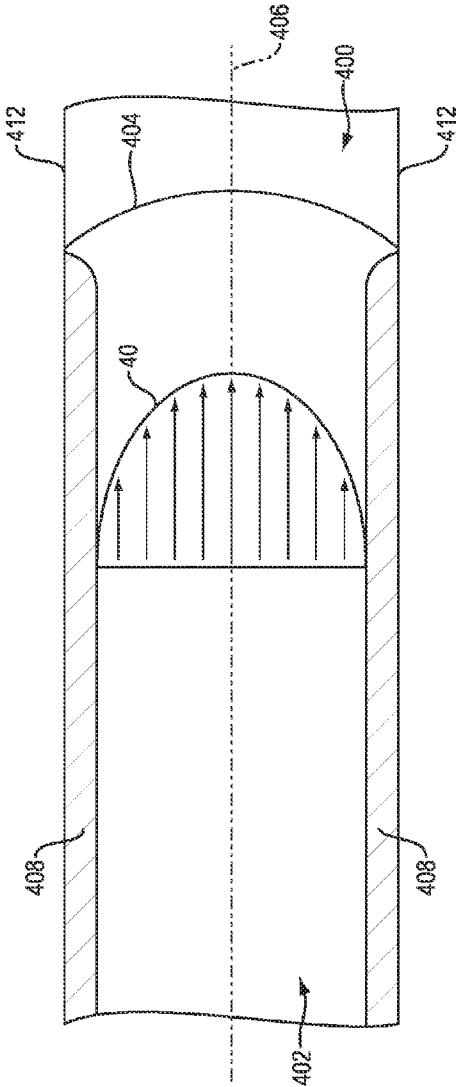

FIG. 4

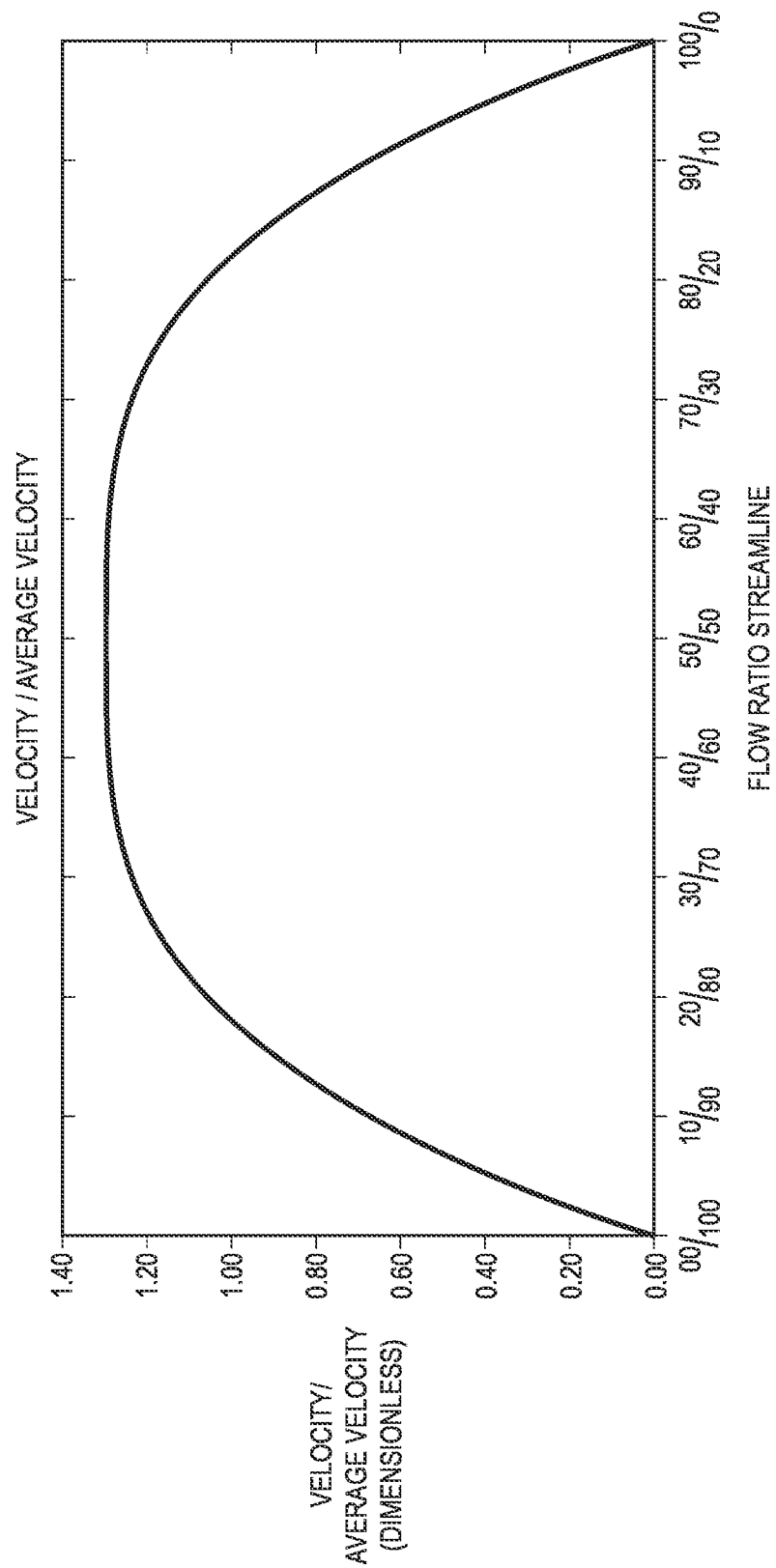

FIG. 5

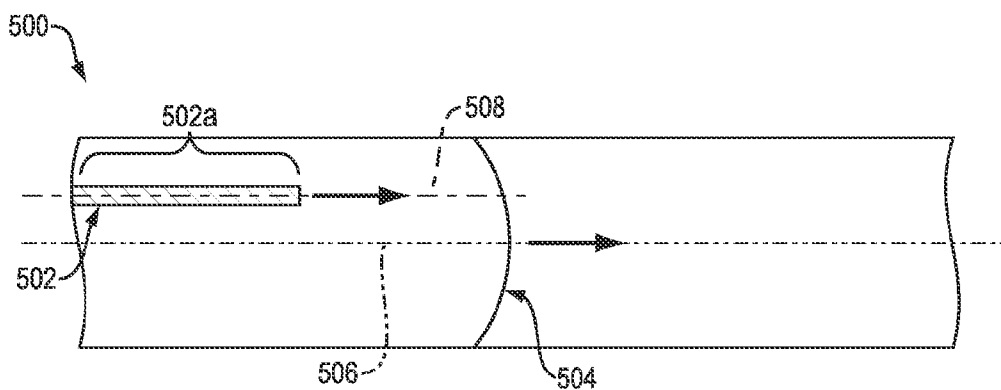

FIG. 6

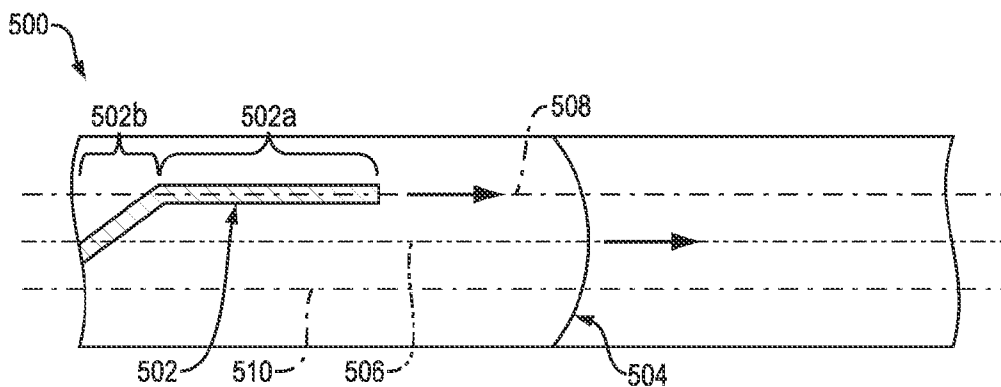

FIG. 7

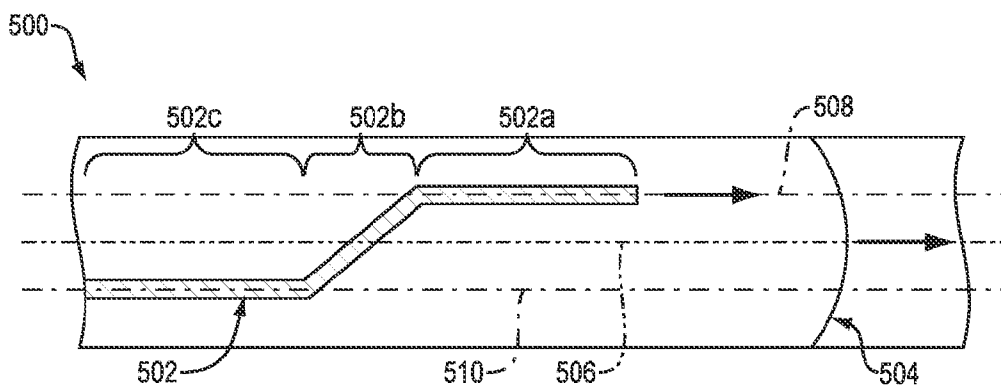

FIG. 8

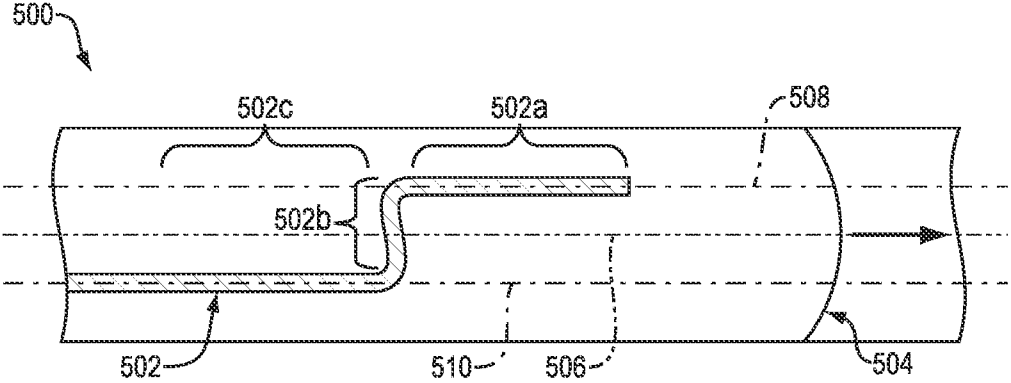

FIG. 9

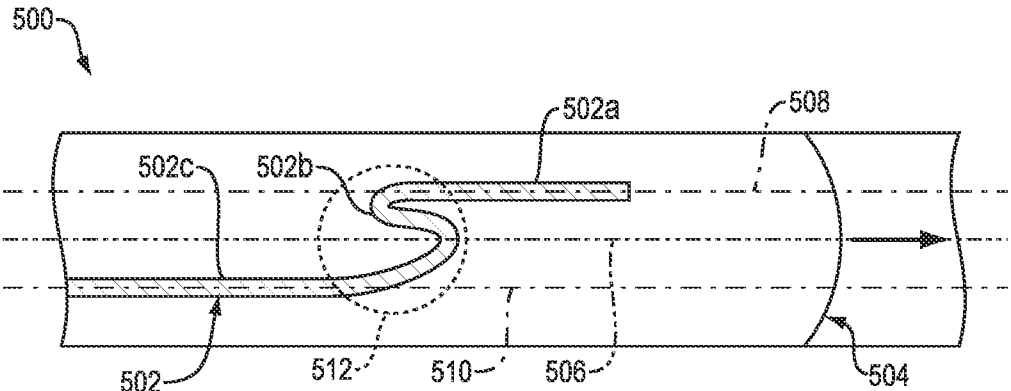

FIG. 10

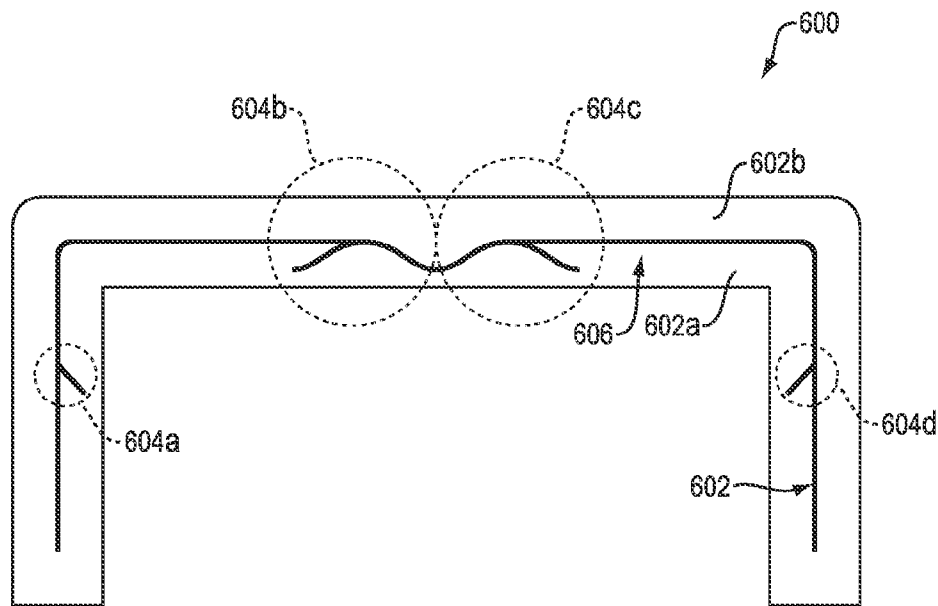

FIG. 11

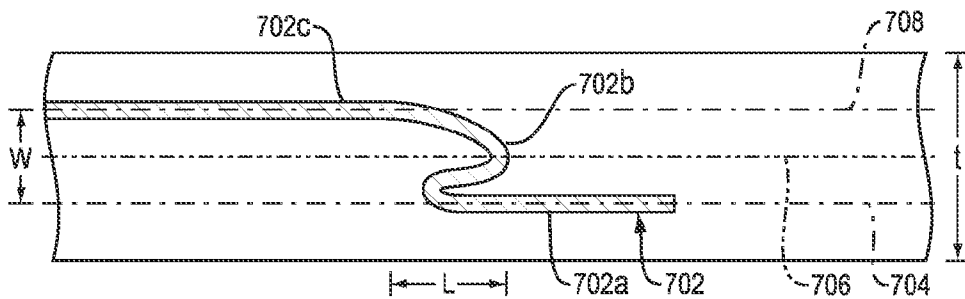

FIG. 12

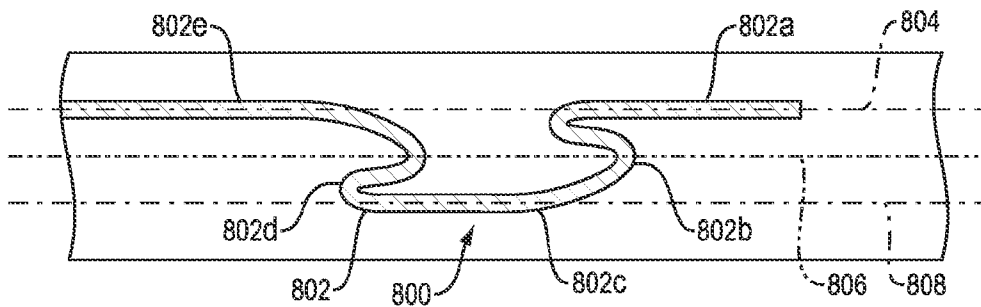

FIG. 13



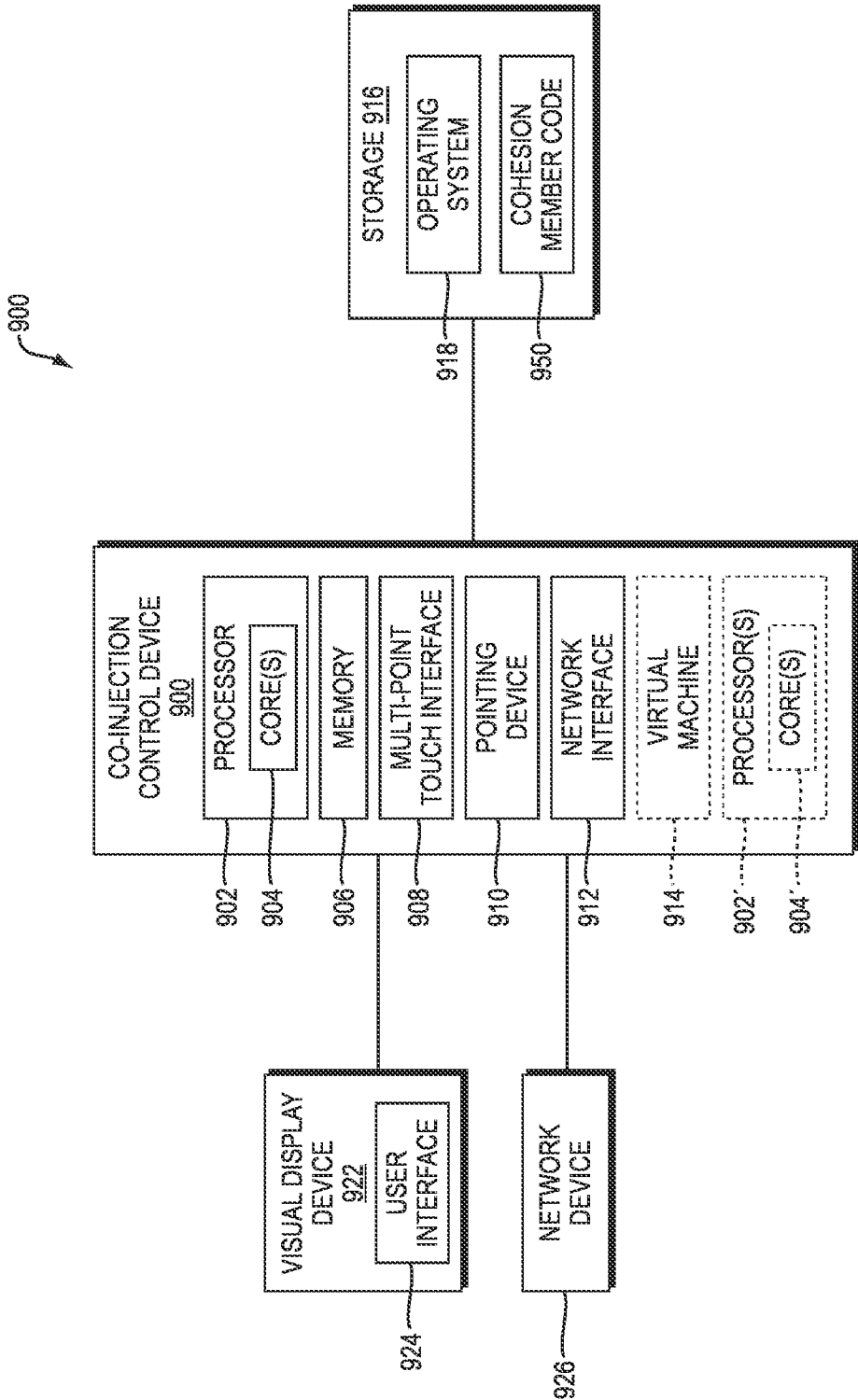

FIG. 14

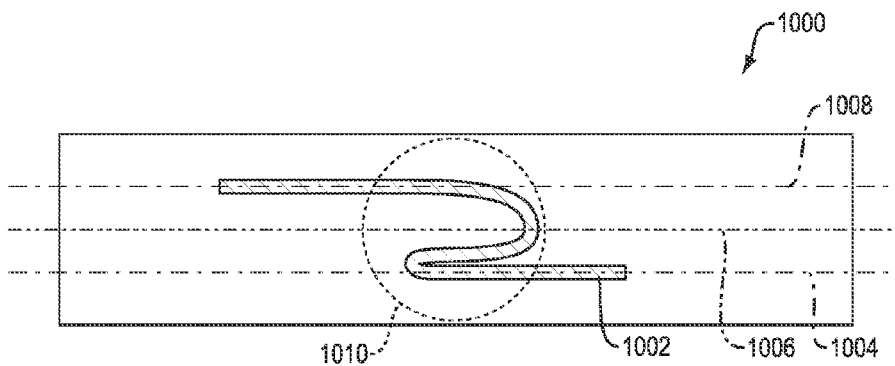

FIG. 15

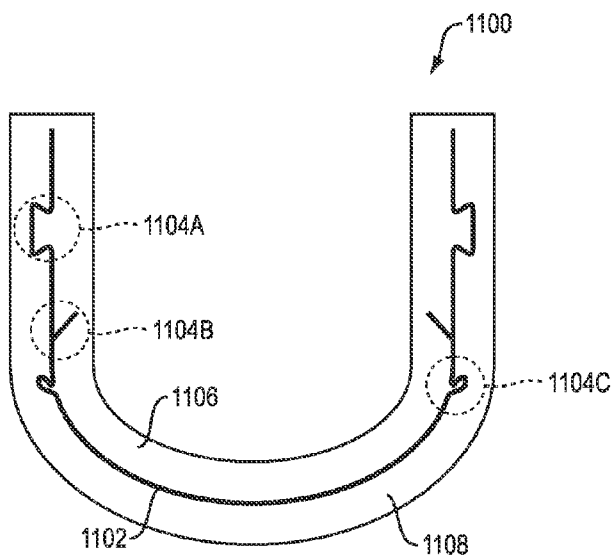

FIG. 16

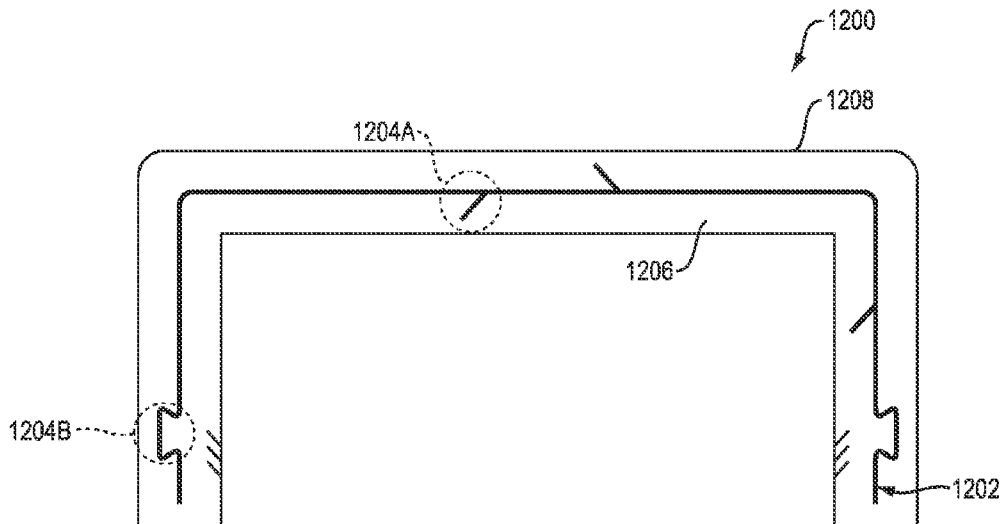

FIG. 17

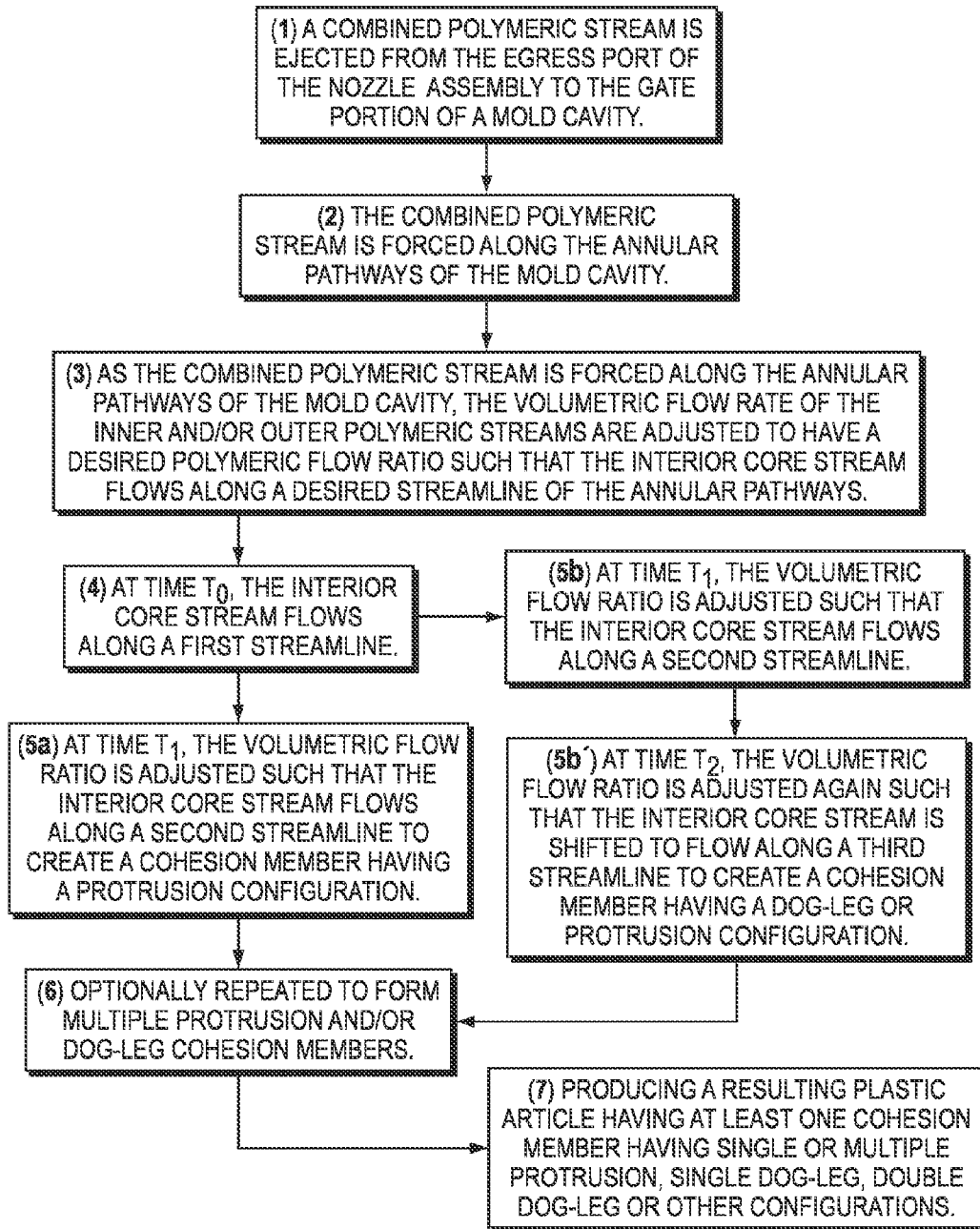

FIG. 18

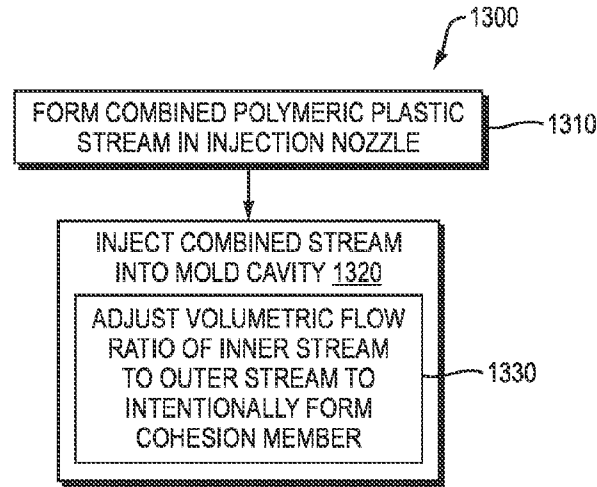

FIG. 19

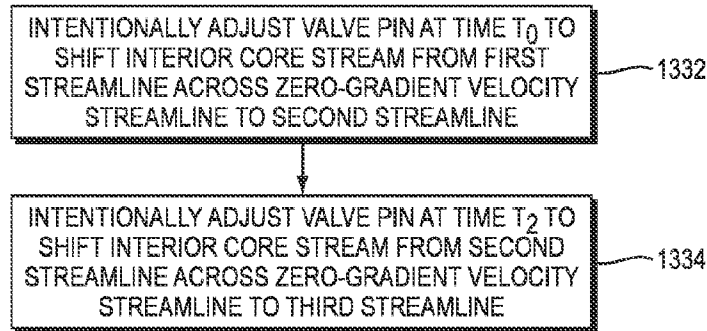

FIG. 20

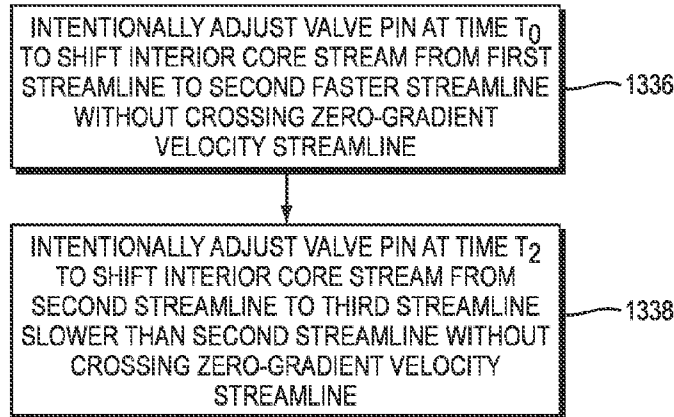

FIG. 21

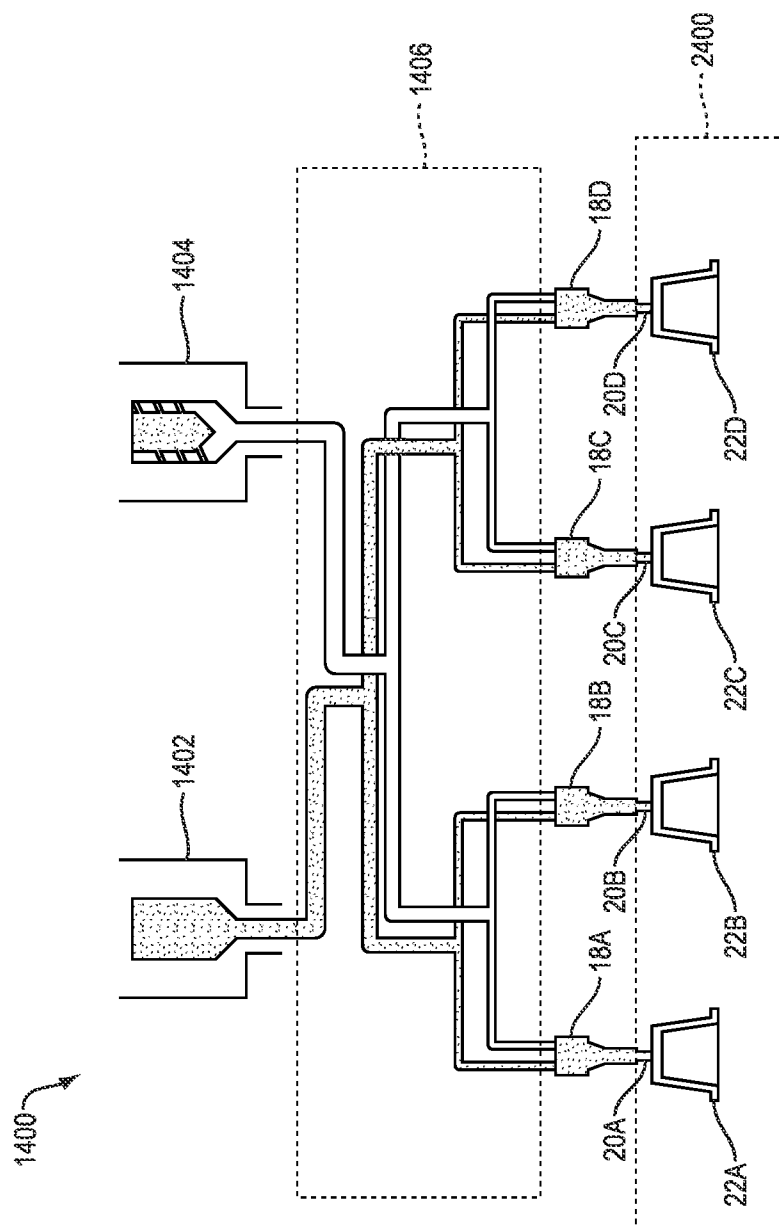

FIG. 22

**METHODS AND SYSTEMS FOR THE  
PREPARATION OF MOLDED PLASTIC  
ARTICLES HAVING A STRUCTURAL  
BARRIER LAYER**

**CROSS-REFERENCE TO RELATED  
APPLICATION**

[0001] This application claims priority to and benefit of U.S. Provisional Patent Application No. 61/526,495, filed Aug. 23, 2011, the disclosure of which is incorporated herein by reference in its entirety.

**TECHNICAL FIELD**

[0002] Many plastic articles, such as caps, lids and other closures, cups, preforms, and various other containers, are formed from injection molding processes. In some instances, the molding process is a co-injection process in which an annular combined stream of polymeric materials is forced along one or more pathways of an injection apparatus and into a mold cavity that forms the article to a desired configuration. The combined stream includes an annular interior core stream sandwiched between an annular inner stream and an annular outer stream. The interior core stream is a first polymeric material and the inner and outer streams are of at least one other polymeric material. In the resulting molded plastic article, the interior core stream material forms an interior core layer while the inner and outer stream materials form an inner skin layer and an outer skin layer, respectively, which encase the interior core layer.

[0003] Illustrative embodiments relate to systems and methods to facilitate cohesion of the interior core layer with the inner and outer layers that form the skin of the resulting plastic article with a reduced requirement for an adhesive to bond the inner, interior and outer layers together.

**BACKGROUND**

[0004] In forming polymeric plastic articles by injection or co-injection molding processes, it is often desirable to produce a plastic article having an interior core layer of a first polymeric material and a skin of at least one other polymeric material. The interior core layer is formed from an interior core stream of the first polymeric material. The skin, which has an inner layer and an outer layer, is formed from an inner and an outer stream of at least one other polymeric material. The same polymeric material(s) may be used for both the inner stream/inner layer and the outer stream/outer layer, or different polymeric materials may be used for the inner stream/inner layer than for the outer stream/outer layer.

[0005] The interior core stream is combined with the inner and outer streams to form an annular combined polymeric stream. Various methods of combining the polymeric streams may be employed. For example, the combined polymeric stream may be formed by sandwiching an annular interior core stream with an annular inner stream and an annular outer stream in an apparatus used to inject the combined stream into a mold cavity. The combined stream is then forced along the annular pathways of the mold cavity to form a molded plastic article having desired dimensions (i.e., configuration, thickness, etc.).

[0006] The interior core stream material is often selected such that the interior core stream forms an interior core layer in the resulting plastic article that functions, in some instances, as a barrier layer or as a scavenger layer. The barrier

layer prevents foreign substances from invading the environment enclosed by the plastic article and/or prevents substances within the plastic article from escaping to the outside environment. One example of a scavenger layer is an oxygen scavenger layer

[0007] In some situations, the barrier material and the skin materials do not adhere to each other without adding an adhesive material to the skin material, to the barrier material, or to both. Accordingly, in order to improve the adhesion of the interior core layer and the skin layers, adhesives are generally added before or during the molding process. For example, in some instances, an adhesive is added to the polymeric material that forms the skin, to the polymeric material that forms the interior layer, or to both.

**SUMMARY**

[0008] Some illustrative embodiments provide methods and systems for preparing molded plastic articles that achieve adhesion between an interior core layer and skin layers of the molded plastic article with a reduced amount of adhesive or with no adhesive.

[0009] Some embodiments include methods and systems that control the volumetric flow of the inner and outer polymeric streams that form the inner and outer layers of the skin, respectively, such that a resulting plastic article has an interior core layer whose configuration interlocks with the skin inner layer, with the skin outer layer, or with both. In some embodiments, a plurality of polymeric plastic material streams are co-extruded to produce the resulting molded plastic article.

[0010] Some embodiments provide a method of co-extruding a plurality of plastic material streams to produce a resulting molded multi-layer plastic article including one or more cohesion members that structurally interlock an interior core layer with an inner skin layer, with an outer skin layer, or with both layers in the resulting plastic article. An example method includes forming an combined polymeric plastic stream in an injection nozzle, where the combined stream includes an annular interior core stream of a first polymeric material encased by an inner stream of a second polymeric material and an annular outer stream of the second polymeric material. The method also includes injecting the combined stream along the pathways into a mold cavity. The method further includes adjusting a the volumetric flow ratio of the inner stream to the outer stream during injection of the combined stream into a mold cavity to intentionally form the cohesion member from the interior core stream.

[0011] In some embodiments, adjusting the volumetric ratio of the inner stream to the outer stream includes adjusting a valve pin at a time  $T_1$  to shift the interior core stream from flowing along a first streamline with a volumetric flow ratio between about 5:95 and about 95:5 across a streamline at a zero-gradient of a velocity profile of a flow front of the combined polymeric plastic stream (the zero-gradient of velocity streamline) to flowing along a second streamline.

[0012] In some embodiments, adjusting the volumetric ratio of the inner stream to the outer stream includes adjusting a valve pin at a time  $T_1$  to shift the interior core stream from flowing along a first streamline with a volumetric flow ratio between about 5:95 and about 95:5 to flowing along a second streamline that has a velocity greater than the first streamline without crossing the zero-gradient velocity streamline. In some embodiments, the second streamline may be the zero-gradient velocity streamline.

**[0013]** In some embodiments, after shifting the interior core stream from a first streamline to a second streamline at time  $T_1$ , the method further includes adjusting the valve pin at a later time  $T_2$  to shift the interior core stream from flowing along the second streamline to flowing along a third streamline. In some embodiments, the time interval between time  $T_1$  and time  $T_2$  is between about 5 milliseconds and about 50 milliseconds. In some embodiments, the third streamline is across the zero-gradient velocity streamline from the second streamline and the second streamline is away from the zero-gradient velocity streamline. The velocity along the third streamline may be less than the velocity along the second streamline. In some embodiments, the third streamline is the same as the first streamline.

**[0014]** In some embodiments, a magnitude of a length (L) of the cohesion member is the same as or less than a magnitude of a local thickness (T) of the resulting article at the cohesion member, which may result in a greater cohesive force between the cohesive member and one or both of the skin layers than if the magnitude of the length of the cohesion member were greater than the magnitude of the local thickness.

**[0015]** In some embodiments, the first polymeric material comprises ethyl vinyl alcohol (EVOH) and the second polymeric material comprises polypropylene.

**[0016]** In some embodiments, the viscosity of the interior core stream falls in the range of 40-400 Pa-sec.

**[0017]** In some embodiments, a cosmetic effect is formed in the resulting molded plastic article by the shifting of the interior core stream. In some embodiments a color of the interior core stream is visually distinguishable in the resulting molded plastic article.

**[0018]** In some embodiments, the first polymeric material and the second polymeric material are substantially free of adhesive. In some embodiments, the resulting interior, inner and outer layers are free of, or substantially free of, adhesive, or include a smaller amount of adhesive, or a lower proportion of adhesive, than would be required in the absence of the cohesion member.

**[0019]** In some embodiments, the cohesion member is formed during a filling phase of a molding cycle. In some embodiments, the cohesion member is formed during a packing phase of a molding cycle. In some embodiments the cohesion member is formed during both a filling phase and a packing phase of a molding cycle.

**[0020]** Some embodiments provide a co-injection molded multi-layer plastic article having one or more cohesion members that structurally interlock an interior layer of the article to the inner layer of the article, to the outer layer, or to both. An example co-injection molded multi-layer plastic article has an inner layer including a first polymeric material and an outer layer including the first polymeric material. The article also has an interior core layer including a second polymeric material. The interior core layer is disposed between the inner layer and the outer layer and intentionally configured to form a cohesion member structurally interlocking the interior core layer to the inner layer, to the outer layer, or to both.

**[0021]** In some embodiments, a magnitude of a length (L) of the cohesion member is the same as or less than a magnitude of a local thickness (T) of the multi-layer plastic article at the cohesion member. In some embodiments cohesion member is formed of a first segment of the interior core layer overlapping a second segment of the interior core layer within a thickness of the article. In some embodiments, the cohesion

member is formed of a segment of the interior core layer protruding into the inner layer, into the outer layer, or protruding into both.

**[0022]** In some embodiments, none of the interior core layer, the inner layer and the outer layer includes a compounded adhesive.

**[0023]** The molded plastic article may be for use as a closure, or suitable for use as a container, or suitable for another use.

**[0024]** Some embodiments provide a system for forming a multi-layer molded plastic article having a cohesion member. For example, in some embodiments, the system includes a mold having a plurality of cavities to mold a plurality of multi-layered plastic articles, a first material source to supply a first polymeric material for use in forming at least one layer of each of the plurality of multi-layered plastic articles, and a second material source to supply a second polymeric material for use in forming at least one layer of each of the plurality of multi-layered plastic articles. The system also includes a plurality of nozzles in communication with a portion of the mold to inject the first and second polymeric materials into each of the plurality of cavities. Each nozzle is configured to form a composite stream including an inner stream including a first material, an annular outer stream including the first material, and an annular interior core stream including a second material, with the interior core stream the inner stream and the outer stream. Each nozzle is further configured for adjustment of a volumetric ratio of the of the inner stream to the outer stream in the composite stream flow ejected from the nozzle. The system also includes a first set of flow channels configured to distribute the first polymeric material from the first material source to each of the plurality of nozzles and a second set of flow channels configured to distribute the second polymeric material from the second material source to each of the plurality of nozzles. The system further includes a processor programmed to adjust a volumetric ratio of the inner stream to the outer stream in the composite stream flow ejected from the nozzle during ejection of the composite streams from the nozzles into the plurality of cavities, forming a cohesion member in each cavity from the interior core stream that structurally interlocks an interior layer of the resulting molded plastic article formed from the interior core stream with an inner layer of the resulting molded plastic article formed from the inner stream, with an outer layer of the resulting molded plastic article formed from the outer stream, or with both.

**[0025]** In some embodiments, the processor is further programmed to control a position of a valve pin in each of the plurality of nozzles to control the volumetric ratio of the inner flow stream to the outer flow stream. In some embodiments, the cohesion member is formed during a filling phase of a molding cycle, during a packing phase of the molding cycle or during both. In some embodiments, the inner layer, the outer layer and the interior core layer of the resulting articles produced by the system are substantially free of a compounded adhesive.

**[0026]** Some embodiments provide a computer-readable medium storing computer executable instructions implementing any methods described herein.

**[0027]** In some embodiments, the interior core stream is controlled alternatively with the inner and outer streams, or controlled in combination with controlling the inner and outer streams, to produce the interlocked configuration (i.e. cohesion member) and resulting cohesion of the interior core layer

with the inner and outer skin layers without an adhesive, or with a reduced or lowered amount of adhesive. In some embodiments, the step of controlling the interior core stream includes adjusting the volumetric flow ratio of the inner to outer streams by adjusting a valve pin in the nozzle so as to place the interior core stream at a first streamline wherein the volumetric flow ratio is between about 5:95 and about 95:5. At time  $T_1$ , the valve pin is adjusted to shift the interior core stream to a second streamline with a velocity less than the velocity of the first streamline. At time  $T_2$ , the valve pin is adjusted to intentionally shift the interior core stream back to the first streamline or to a third streamline to form the cohesion member.

**[0028]** In certain embodiments, the step of controlling the interior core stream includes adjusting the volumetric flow ratio of the inner to outer streams by adjusting a valve pin in the nozzle so as to place the interior core stream at a first streamline at a time  $T_0$  such that the volumetric flow ratio of inner stream to outer stream is between about 5:95 and about 95:5 or is between about 20:80 and about 80:20. The steps further include adjusting the valve pin so as to shift the interior core stream to a second streamline across the zero-gradient of the velocity profile of the composite stream (hereafter the “zero-gradient velocity streamline” or the “fastest streamline”) from the first streamline at a time  $T_1$ , and adjusting the valve pin so as to shift the interior core stream to a third streamline across the zero-gradient velocity streamline at a time  $T_2$ , to form a cohesion member with a double dog-leg configuration. In some embodiments, at time  $T_0$  and  $T_2$  the volumetric flow ratio is selected from a range of between about 20:80 to about 80:20, and at time  $T_1$  the volumetric flow ratio is selected from a range of between about 80:20 to about 20:80. In other embodiments, at time  $T_0$  and  $T_2$  the volumetric flow ratio is selected from the group consisting of 5:95, 95:5, 60:40, 75:25 and 80:20, and at time  $T_1$  the volumetric flow ratio is selected from the group consisting of 20:80, 25:75 and 40:60.

**[0029]** In certain other embodiments, the step of controlling the interior core stream includes adjusting the volumetric flow ratio of the inner to outer streams by adjusting a valve pin in the nozzle so as to place the interior core stream at a first streamline at a time  $T_0$  wherein the volumetric flow ratio is between about 5:95 and about 95:5, and adjusting the valve pin so as to shift the interior core stream to a second streamline at a time  $T_1$  without crossing the zero-gradient velocity streamline, and adjusting the valve pin so as to shift the interior core stream to a third streamline between the first and second streamline, such that a cohesion member is formed. In some embodiments, the cohesion member has a double dog-leg configuration. In some embodiments, at time  $T_0$  the volumetric flow ratio is between about 20:80 and about 40:60, and at time  $T_1$  the volumetric flow ratio is between about 50:50 and the volumetric flow ratio at time  $T_0$ . At time  $T_2$  the volumetric flow ratio is between about 20:80 the volumetric flow ratio at time  $T_1$ . In other embodiments, at time  $T_0$  the volumetric flow ratio is between 80:20 and about 60:40, and at time  $T_1$  the volumetric flow ratio is between about 50:50 and the volumetric flow ratio at time  $T_0$ , and at time  $T_2$  the volumetric flow ratio is between about 80:20 and the volumetric flow ratio at time  $T_1$ .

**[0030]** In certain other embodiments, the step of controlling the interior core stream includes adjusting the volumetric flow ratio of the inner to outer streams by adjusting a valve pin in the nozzle so as to place the interior core stream at a first

streamline at a time  $T_0$  wherein the volumetric flow ratio is between about 5:95 and about 95:5, and adjusting the valve pin so as to shift the interior core stream to a second streamline at a time  $T_1$  across the zero-gradient velocity streamline, such that a cohesion member is formed. In some embodiments, the cohesion member has a single dog-leg configuration. In some embodiments, at time  $T_0$  the volumetric flow ratio is between about 20:80 and about 50:50, and at time  $T_1$  the volumetric flow ratio is between about 50:50 and about 80:20. In other embodiments, at time  $T_0$  the volumetric flow ratio is between about 80:20 and about 50:50, and at time  $T_1$  the volumetric flow ratio is between about 50:50 and about 20:80.

**[0031]** In certain other embodiments, the step of controlling the interior core stream includes adjusting the volumetric flow ratio of the inner to outer streams by adjusting a valve pin in the nozzle. The adjusted valve pin places the interior core stream at a first streamline at a time  $T_0$  such that the volumetric flow ratio is between about 5:95 and about 95:5. The valve pin is then adjusted so as to shift the interior core stream to a second streamline at a time  $T_1$  without crossing the zero-gradient velocity streamline. The resulting cohesion member has a single dog-leg configuration. In some embodiments, at time  $T_0$  the volumetric flow ratio is between about 5:95 and about 50:50, and at time  $T_1$  the volumetric flow ratio is between about 50:50 and the volumetric flow ratio selected at time  $T_0$ . In other embodiments, at time  $T_0$  the volumetric flow ratio is between about 50:50 and about 95:5, and at time  $T_1$  the volumetric flow ratio is between about 50:50 and the volumetric flow ratio selected at time  $T_0$ .

**[0032]** In certain other embodiments, the step of controlling the interior core stream includes adjusting the volumetric flow ratio of the inner to outer streams by adjusting a valve pin in the nozzle so as to place the interior core stream at a first streamline at a time  $T_0$  wherein the volumetric flow ratio is about 50:50, and adjusting the valve pin so as to shift the interior core stream to a second streamline at a time  $T_1$  wherein the volumetric flow ratio is either between about 5:95 and about 50:50 or between about 50:50 and about 95:5, and adjusting the valve pin so as to shift the interior core stream to a third streamline at a time  $T_2$  wherein the volumetric flow ratio is between about 50:50 and the volumetric flow ratio at selected at time  $T_1$ , such that a cohesion member is formed having a single protrusion dog-leg configuration. In some embodiments, the volumetric flow ratio at time  $T_1$  is between about 5:95 and about 50:50, and the volumetric flow ratio at time  $T_2$  is between about 50:50 and the volumetric flow ratio selected at time  $T_1$ . In other embodiments, the volumetric flow ratio at time  $T_1$  is between about 50:50 and about 95:5, and the volumetric flow ratio at time  $T_2$  is between about 50:50 and the volumetric flow ratio selected at time  $T_1$ .

**[0033]** In some embodiments, the time between  $T_0$  and  $T_1$  is between about 5 and 50 milliseconds. In some embodiments, the viscosity of the interior core stream is between 40 and 4000 Pa-sec. In some embodiments, the flow thickness of the interior core stream is between about 10 microns and about 50 microns.

**[0034]** In some embodiments, a cosmetic effect is formed by the interlocking of the interior core layer and the skin. In some embodiments, the color of the interior core stream is visually distinguishable from the inner and outer streams.

**[0035]** In some embodiments, the interior core stream and interior core layer are formed from ethyl vinyl alcohol (EVOH). Other suitable materials that may be used as the



interior core layer include, but are not limited to nylon, polyethylene naphthalate (PEN), and cyclic olefin copolymers (COCs). In some embodiments, the skin layers (i.e., the inner and outer layers) are formed from polymeric plastic materials such as polyethylene terephthalate (PET), high-density polyethylene (HDPE), polypropylene (PP), and polycarbonate (PC).

**[0036]** In certain embodiments, a molded plastic article includes an inner layer, an outer layer, and an interior core layer encased by the inner and outer layer, where the interior layer includes a cohesion member configured to secure the interior layer to the inner or to the outer layer. In some embodiments, the inner layer, the outer layer and the interior core layer are free of compounded adhesive. In some embodiments, one or more of the inner layer, the outer layer and the interior core layer have a reduced amount of adhesive relative to a molded plastic article without a cohesion member. The configuration of the cohesion member prevents the interior core layer from delaminating from the skin without the need for adhesives, or with a reduced need for adhesive.

**[0037]** In some embodiments, the molded plastic article is an article suitable for use as a closure mechanism or as a device for covering an open end of a container. In other embodiments, the plastic article is an article suitable for use as a container.

**[0038]** Certain embodiments provide a system for forming a molded plastic article having a cohesion member. In some embodiments, the system comprises a mold having a plurality of cavities to mold a plurality of multi-layered plastic articles. The system includes a first material source to supply a first polymeric material for use in forming at least one layer of each of the plurality of multi-layered plastic articles; a second material source to supply a second polymeric material for use in forming at least one other layer of each of the plurality of multi-layered plastic articles; a plurality of nozzles in communication with a portion of the mold to inject the first and second polymeric materials into each of the plurality of cavities; a first set of flow channels configured to distribute the first polymeric material from the first material source to each of the plurality of nozzles; a second set of flow channels configured to distribute the second polymeric material from the second material source to each of the plurality of nozzles; and a processor programmed to control a volumetric ratio of an inner flow stream to an outer flow stream formed from the first polymeric material in one of the nozzles to selectively change a flow stream of the first polymeric material to form a cohesion member to secure an interior layer to an inner layer or to an outer layer of the resulting multi-layered plastic article. The cohesion member is a structural element that secures the interior layer to the inner layer or the outer layer of the resulting multi-layered plastic article without adhesive or with a reduced need for adhesive. In some embodiments, the first and/or second polymeric materials are free of a compounded adhesive. In some embodiments, the processor is programmed to control a position of a valve pin in each of the plurality of nozzles to control the volumetric ratio of the inner stream to the outer stream.

**[0039]** In some embodiments, a computer readable medium, storing computer executable instructions for performing a method of co-extruding a plurality of polymeric plastic material streams to form a resulting molded plastic article having a cohesion member, is provided. The medium stores instructions for: forming a combined polymeric stream comprising an inner flow stream and an outer flow stream of

a first polymeric material and an interior flow stream of a second polymeric material, and controlling the volumetric flow ratio of the inner flow stream to the outer flow stream to intentionally form a cohesion member from the interior core stream. The cohesion member interlocks an interior layer of the resulting molded plastic article with one or both of an inner layer and an outer layer of the resulting molded plastic article. Further, in some embodiments, the first and second polymeric plastic materials are substantially free of adhesive.

#### BRIEF DESCRIPTION OF THE DRAWINGS

**[0040]** FIG. 1 is a cross-sectional view of an exemplary nozzle assembly suitable for use in the methods and systems described herein.

**[0041]** FIG. 2 is a cross-sectional view of another exemplary nozzle assembly, suitable for use in the methods and systems described herein.

**[0042]** FIG. 3 is a cross-sectional view of a portion of a wall of an exemplary plastic article that includes a cohesion member made by the process described herein.

**[0043]** FIG. 4 is a cross-sectional view of the velocity profile of a polymeric stream as it flows along a pathway of a mold cavity, in accordance with some embodiments.

**[0044]** FIG. 5 is a graph of dimensionless velocity as a function of position in the flow layer for various streamlines along a composite flow.

**[0045]** FIGS. 6 to 10 are cross-sectional views of a portion of a pathway in a mold cavity at successive times as a composite stream flows along the pathway and an interior polymeric stream of the composite stream is adjusted from one streamline to another to generate a cohesion member, in accordance with some embodiments.

**[0046]** FIG. 11 is a cross-sectional view of an exemplary plastic article that has multiple cohesion member formed by some exemplary methods and systems described herein.

**[0047]** FIG. 12 is a cross-sectional view of an exemplary interior core stream adjusted to form a cohesion member in which a characteristic length (L) of the cohesion member is of the same magnitude, or less than, the local thickness (T) of the combined stream.

**[0048]** FIG. 13 is a cross-sectional view of an exemplary plastic article having a double dog-leg configuration cohesion member formed by some methods and systems described herein.

**[0049]** FIG. 14 illustrates an exemplary computing environment suitable for practicing embodiments taught herein.

**[0050]** FIG. 15 is a cross-sectional view of a portion of an exemplary plastic article having a single dog-leg configuration cohesion member formed by some methods and systems described herein.

**[0051]** FIG. 16 is a cross-sectional view of an exemplary plastic article formed as a container having multiple cohesion members formed using some methods and systems described herein.

**[0052]** FIG. 17 is a cross-sectional view of an exemplary plastic article formed as a closure device having multiple cohesion members formed using some methods and systems described herein.

**[0053]** FIG. 18 is a flow chart schematically depicting the production of certain exemplary plastic articles using the methods and systems described herein.

[0054] FIG. 19 is a flow chart schematically depicting a method of co-injection molding a multilayer plastic article having a plurality of cohesion members, in accordance with some embodiments.

[0055] FIG. 20 is a flow chart schematically depicting steps that may be performed in adjusting a volumetric ratio of the inner stream to the outer stream to intentionally form a cohesion member, in accordance with some embodiments.

[0056] FIG. 21 is a flow chart schematically depicting other steps that may be performed in adjusting a volumetric ratio of the inner stream to the outer stream to intentionally form a cohesion member, in accordance with some embodiments.

[0057] FIG. 22 is a cross-sectional view of a molding apparatus suitable for use in the methods described herein.

[0058] As will be appreciated by one of skill in the art, the drawings are schematic, are not drawn to scale and do not accurately indicate relative dimensions. Throughout the drawings, dimensions (e.g. layer thicknesses) are exaggerated for illustrative purposes.

## DETAILED DESCRIPTION

### I. Definitions

[0059] In accordance with the present disclosure and as used herein, the following terms are defined with the following meanings, unless explicitly stated otherwise.

[0060] As used herein, the term “volumetric flow ratio” refers to the ratio of the volume of the inner polymeric stream flowing per unit time to the volume of the outer polymeric stream flowing per unit time in a combined polymeric flow stream. For example, a 20:80 volumetric flow ratio refers to the combined flow of the inner and outer streams in which 20% of the combined flow (volume per unit time) is the inner polymeric stream and 80% of the combined flow (volume per unit time) is the outer polymeric stream. At a 50:50 volumetric flow ratio, the inner and outer polymeric streams have equal volumes flowing per unit time, with each forming 50% of the combined stream.

[0061] As used herein, the terms “zero-gradient of velocity streamline,” “zero-gradient velocity streamline,” “zero-velocity,” and “zero-velocity streamline” are used interchangeably to refer to the fastest streamline of the combined polymeric stream flow front, which occurs at the zero gradient of the velocity profile for the composite flow. Generally speaking, the fastest streamline, which is the streamline at the zero gradient of the velocity profile, corresponds to about a 50:50 volumetric flow ratio of the inner polymeric stream to the outer polymeric stream. Thus, the term “50:50 streamline” may also be used to refer to the fastest streamline of the combined polymeric stream flow front.

[0062] As used herein, the term “dog-leg” refers to a configuration of some of the structural cohesion members. The dog-leg configuration includes a continuous layer of polymeric material. The dog-leg configuration is formed from an interior core stream that flows along multiple streamlines of a combined polymeric stream such that in a cross-sectional view of the combined polymeric stream, the interior core stream overlaps on itself as depicted, for example, FIG. 10.

[0063] As used herein, the term “adhesion,” or “adhesive” refers to any means by which two or more structural parts of a composite structure are joined to prevent delamination. Adhesion includes at least one of structural cohesion and chemical bonding of the structural parts to each other. As used herein, the term “bond” or “bonding” refers to adhesion of

two or more structural parts of a composite structure, wherein the adhesion is due primarily to the chemical bonding of the structural parts.

[0064] As used herein, the term “cohesion,” or “cohesive” refers primarily to the adhesion of two or more structural parts of a composite structure, wherein the adhesive effect is due to the structural interlocking of the structural parts. As used herein, the term “cohesion member” is a structural element. It refers to an overlapping interior core layer or to a protrusion extending from an interior core layer of a molded plastic article that causes the interior core layer to interlock with a skin of the molded plastic article reducing or eliminating the need for, or use of, adhesives.

[0065] As used herein, the phrases eliminating or reducing the need to incorporate adhesives, and similar phrases, refer to systems and methods employing no adhesive or employing less adhesive that would be required if no “cohesion member” were formed.

### II. Description

[0066] Exemplary embodiments provide methods and systems for the manufacture of molded plastic articles. The molded plastic articles include an interior core layer that is encased by a skin, which includes an outer skin layer an inner skin layer. The molded plastic articles are formed by injecting a combined polymeric stream into a mold cavity and forcing the combined polymeric stream along pathways of the mold cavity. The combined polymeric stream includes an annular interior core polymeric stream that is sandwiched between an annular inner polymeric stream and an annular outer polymeric stream. The interior core layer is formed from the annular interior core polymeric stream. The inner and outer skin layers are formed from the annular inner polymeric stream and the annular outer polymeric stream, respectively. As the combined polymeric stream is formed, the volumetric flow ratio of the inner polymeric stream to the outer polymeric stream is adjusted at selected and desired time points, such that the interior core stream is shifted from flowing along a first streamline to flowing along another streamline for a desired time interval. The number of shifts and the time interval between shifts determine the placement and the structure of the cohesion member(s) formed in the resulting article. For example, multiple shifts in position of the interior core stream performed at relatively shorter time intervals increase the number of cohesion members formed in the resulting article. As another example, multiple shifts in position of the interior core stream performed at relatively longer time intervals decrease the number of cohesion members formed in the resulting article. The flow ratios of the inner stream, the outer stream and the interior stream are adjusted to create the desired cohesion member structure(s) at the desired location (s) in each molded article.

[0067] The shifts in streamline of the interior core stream form one or more structural elements in the form of one or more cohesion member(s) that secure the interior core layer to the skin layers, thereby increasing the adhesion of the interior core layer and the skin, which reduces or eliminates the need for incorporating adhesives into the process of preparing the molded plastic article. Examples of resulting plastic articles include, but are not limited to, cups, preforms, closures, bottles, and vials. Cohesion of the interior core layer to the skin is important to prevent delamination. The cohesion member(s) secure the interior core layer to the skin thereby increasing the adhesion of the interior core layer and the skin

layers, preventing delamination, and reducing or eliminating the need for incorporating adhesives into the process of preparing the molded plastic article.

[0068] Taught herein are methods and systems that reduce or eliminate the need for including an adhesive in the co-extrusion molding process, for example, the need to compound an adhesive into a polymeric material used in the molding process. Embodiments taught herein improve the cohesion of the interior core layer to the skin by shifting the streamline of the interior core stream within the composite stream such that the interior core stream forms an interior core layer that has at least one cohesion member.

[0069] Articles in which, an interior core layer is formed from a first polymeric material and the one or more of the skin layers are formed from a different polymeric material are subject to failure by delamination of different layers formed from different materials. In such articles, the structural element formed by the interior core layer is important in prevent delamination of the layers when no adhesive or a reduced amount of adhesive is present in the polymeric materials.

[0070] Materials suitable for use with embodiments of the invention include, but are not limited to, polymer-based materials such as, polyethylene terephthalate (PET), ethylene vinyl alcohol (EVOH), MXD6 nylon, polypropylene (PP), and polycarbonates (PC). In some embodiments, the inner and outer streams are the same or different polymeric materials. For example, in some embodiments, the inner and outer streams which form inner and outer layers are PET, while an interior stream used to form an interior layer is a material chosen to enhance the overall performance of the resulting article, or to reduce the cost of the resulting article. For example, one or more interior streams for interior layers may include one or more of a barrier material (MXD6 Nylon or EVOH), an oxygen scavenging material, a recycled material, or other performance-enhancing or cost-reducing material. The type of material used for the interior layer/stream is often different from the type of material used for the inner and outer layers/streams.

[0071] In some embodiments, the interior core layer, functions as a barrier layer shielding the environment enclosed by the plastic article from intrusion by the environment outside the plastic article. The interior core further functions to prevent the diffusion of enclosed materials to the outside environment. The interior core may further function as a scavenger layer to remove or inactivate an impurity.

[0072] For example, some multi-layer plastic articles are commonly made from materials such as polyethylene (PET) and polypropylene (PP), which resist environmental degradation, and are reasonably durable, watertight, and economically produced, but are gas permeable (e.g., permeable to oxygen, nitrogen, etc.). For applications in which gas permeability is undesirable (e.g., containers for food products, medicines and products that degrade upon gaseous exposure) a plastic article with gas permeable skin layers (e.g., layers of PET or PP) may include an interior layer of a barrier material and/or a gas scavenger material, such as ethylene vinyl alcohol (EVOH), between skin layers of PET or PP.

[0073] The interior core layer may, for example, include one or more layers of a barrier material, oxygen scavenging material, recycled material, or other performance-enhancing or cost-reducing material. Suitable polymeric materials for use as the interior core layer or barrier layer include, but are not limited to, MXD6 nylon, EVOH, COC, and PEN. The material used for the interior core layers/streams is often,

though not exclusively, different from the material used for the inner and outer layers/streams.

[0074] The inner and outer layers, which form the skin, may include polyethylene terephthalate (PET) or polypropylene. The various embodiments provide methods and systems whereby the non-adhesive cohesion between the interior core layer and the skin is improved such that the inner and outer layers, or in certain embodiments, the interior core layer, are free of or substantially free of adhesives. In some embodiments the combined polymeric stream is substantially free of adhesives. In other embodiments, the combined polymeric stream is completely free of adhesives.

[0075] FIG. 1 illustrates an exemplary nozzle assembly that is suitable for use with the exemplary methods and systems disclosed herein. Nozzle assembly 100 includes a movable valve pin 102, an inner first circular wall 104, a second circular wall 106 and an outer third circular wall 108. The inner first circular wall 104 defines an inner channel 110 that is suitable for accepting an inner polymeric stream. An interior channel 112 suitable for accepting an interior polymeric stream is defined by the inner first circular wall 104 and the second circular wall 106. An outer channel 114 suitable for accepting an outer polymeric stream is defined by the outer third circular wall 108 and the second circular wall 106.

[0076] The first inner channel 110 is coupled to the interior channel 112. The inner channel 110 includes an orifice through which an annular inner flow stream passes and combines with an interior flow stream from the interior channel 112. The annular inner flow stream and the interior flow stream combine in a first combination area 116. The interior channel 112 and the first combination area 116 are coupled to the outer channel 114 by an orifice. The first combination area 116 directs a combined annular flow of the interior flow stream and the inner flow stream into a second combination area 118. The second combination area 118 combines the annular outer flow stream with the combined annular flow stream of the interior flow and inner flow to form a combined annular flow stream having an outer flow stream, an interior flow stream and an inner flow stream. The nozzle 100 further includes an egress port 120 for ejecting the combined polymeric stream. A combined polymeric stream can be forced along the egress port 120 to a gate portion of a mold.

[0077] Movable valve pin 102 can be adjusted to move within and beyond the inner channel 110 to the first combination area 116, to the second combination area 118 and/or beyond the second combination area 118. The moveable valve pin 102 can be adjusted from a first fully open position (e.g., position 151) in the inner channel 110 to a second position (e.g., position 152), whereby the flow of any polymeric material from the inner channel 110 would be halted. Valve pin 102 may also be adjusted to a third fully closed position (e.g., position 153), such that the combined polymeric stream is halted. The moveable valve pin 102 can be placed in a variety of desired positions between the fully open position and the fully closed position to control the volumetric flow of the inner polymeric stream from the inner channel 110 and the volumetric flow of the outer polymeric stream from the outer channel 114. Control over the volumetric flow of the inner polymeric stream and the volumetric flow of the outer polymeric stream in turn controls the position of the interior polymeric stream with respect to the average velocity of the flow front of the combined annular flow stream.

[0078] Upon egress from the nozzle assembly 110, the combined annular polymeric stream includes an annular inte-

rior core stream sandwiched by an annular inner polymeric stream and an annular outer polymeric stream. The combined stream flows along annular flow pathways within the mold cavity with the interior core stream sandwiched between the inner and outer polymeric streams.

[0079] FIG. 2 illustrates another exemplary nozzle assembly that is suitable for use with the exemplary methods and systems disclosed herein. Nozzle assembly 200 includes a movable tapered valve pin 202, an inner first circular wall 204, a second circular wall 206 and an outer third circular wall 208. The inner first circular wall 204 defines an inner channel 210 that is suitable for accepting an inner polymeric stream. An interior channel 212 suitable for accepting an interior polymeric stream is defined by the inner first circular wall 204 and the second circular wall 206. An outer channel 214 suitable for accepting an outer polymeric stream is defined by the outer third circular wall 208 and the second circular wall 206.

[0080] The inner channel 210 is coupled to the interior channel 212 by an orifice. The orifice directs a flow of the inner polymeric material from the inner channel into a first combination area 216. The first combination area 216 combines the annular inner stream of polymeric material from the inner channel 210 with the annular interior stream of polymeric material from the interior channel 212. The interior channel 212 and the first combination area 216 are coupled to the outer channel 214 by an orifice. The annular flow of the inner polymeric stream and the interior polymeric stream combine with the annular flow of the outer polymeric stream in a second combination area 218. The second combination area 218 forms a combined annular flow of the annular inner polymeric stream, the annular interior polymeric stream and the annular outer polymeric stream. The nozzle 200 further includes an egress port 220 for ejecting the combined polymeric stream. A combined polymeric stream can be forced along the egress port 220 to a gate portion of a mold.

[0081] The moveable tapered valve pin has a proximal portion having a first diameter  $D_1$  and distal portion having a second larger diameter  $D_2$ . The movable tapered valve pin 202 can be moved and placed in a number of selected positions between position 251 and position 252, between position 252 and position 253, and between position 253 and position 254. The movement and positioning of the movable tapered valve pin 202 controls the volumetric flow of the inner polymeric stream from the inner channel 210 and the volumetric flow of the outer polymeric stream from the outer channel 214. Control over the volumetric flow of the inner polymeric stream and the volumetric flow of the outer polymeric stream in turn controls the position of the interior polymeric stream with respect to the average velocity of the flow front of the combined annular flow stream.

[0082] For example, the moveable tapered valve pin 202 can be adjusted from position 251 in the inner channel 210 to position 252, to at least partially restrict flow of material from the inner channel 210 into the combination area 216. Moveable tapered valve pin 202 may be adjusted to position 253, which would block flow from the inner channel 210 into the combination area 216 and would partially restrict flow from the interior channel 212 into the combination area 216. With the moveable tapered valve pin 202 adjusted to position 4 the egress port 220 is blocked no flow is ejected out of the nozzle. By adjusting the position of the moveable tapered valve pin 202, the volumetric flow ratio of the combined polymeric stream can also be adjusted to completely or partially restrict

the flow from any of the channels inner channel 210, the interior channel 212 and the outer channel 214.

[0083] When the valve pin 220 is in position 251 or 252 upon exiting the nozzle assembly through egress port 220, the combined annular polymeric stream, which flow along annular flow pathways within the mold cavity, includes an annular interior core stream sandwiched by an annular inner polymeric stream and an annular outer polymeric stream. When the valve pin 220 is in position 253, the inner stream is blocked and the combined stream ejected from the nozzle includes the interior core stream and the outer polymeric stream.

[0084] FIG. 3 depicts a cross-sectional view of a portion of a wall 300 of an exemplary resulting plastic article formed in accordance with the teachings herein. The wall 300 includes an interior core layer 302, a skin 308, which includes an inner skin layer 308a and an outer skin layer 308b, and a cohesion member 304. In the resulting plastic article 300 the cohesion member 304 is formed as a protrusion of the interior core layer 302 into the skin 308 of the resulting plastic article.

[0085] In this embodiment, the cohesion member 304 is formed shifting a position of an interior core stream in the combined flow from a fast streamline, to a slower streamline, and back to a fast streamline during co-injection. For example, at time  $T_0$ , the interior core stream, which forms the interior core layer 302 of the resulting article, travels along a streamline at or near the zero-gradient of the velocity profile streamline (hereafter “the zero-gradient velocity streamline”), which for this example will be referred to as the fast streamline, depicted by center line 306. At time  $T_1$ , within the nozzle, the interior core stream is shifted in position to a slower streamline away from the zero-gradient velocity streamline, and then subsequently shifted back to a faster streamline at time  $T_2$ . In this example, the portion of the interior core stream ejected from the nozzle between times  $T_0$  and  $T_1$  will be referred to as the first interior core stream, the portion of the interior core stream ejected from the nozzle between times  $T_1$  and  $T_2$  will be referred to as the second interior core stream, and the portion of the interior core stream ejected from the nozzle after time  $T_2$  be referred to as the third interior core stream portion.

[0086] As the combined stream flows from the nozzle, into and through the mold cavity, the second interior core stream portion traveling along the slower streamline that is displaced from the zero-gradient velocity streamline increasingly lags behind the first interior core stream portion traveling along the fast, zero-gradient velocity streamline. Further, the shift in position of the interior core layer from the slower streamline back to a faster streamline at time  $T_2$  allows the third interior core stream portion traveling the along the faster streamline, to at least partially catch up with and overlap the second interior core stream portion traveling along the slower along the slower streamline. The overlapping second interior core stream portion and third interior core stream portion forms the single protrusion cohesion member 304 in the resulting article. The cohesion member 304 is a structural member that interlocks the interior core layer 302 with the inner skin layer 308a. In other embodiments, a cohesion member interlocks the interior core layer with the outer skin layer or with both the inner skin layer and the outer skin layer.

[0087] Some embodiments provide methods in which the volumetric flow ratio of the inner to outer streams is controlled to create a cohesion member from the interior core stream. The cohesion member is a structural element that

interlocks the interior core layer with the inner skin layer, with the outer skin layer, or with both to secure the interior core layer to the skin without the need for adhesive, or with a reduced need for adhesive. The interlocking effect of the cohesion member with the skin reduces or eliminates the need for adhesives and thereby improves the non-adhesive cohesion of the interior core layer with the inner and outer layers that form the skin. The cohesion member secures the interior core layer to the skin thereby increasing the adhesion of the interior core layer and the skin, preventing delamination, and thus reducing or eliminating the need for incorporating adhesives into the process of preparing the molded plastic article.

[0088] In some embodiments to form the cohesion member, the volumetric flow ratio of the inner and outer polymeric streams is adjusted to shift the interior core stream from flowing along one streamline to flowing along at least one other streamline. The volumetric flow ratio may be adjusted once or multiple times to obtain a single cohesion member, or may be adjusted multiple times to obtain multiple cohesion members along the interior core layer. In some embodiments, the volumetric flow ratio is changed by movement of the valve pin.

[0089] FIG. 4 depicts an exemplary cross-sectional view of a velocity profile 405 of polymeric stream 402 as it flows along a pathway 400 of a mold. As the polymeric stream 402 flows along, or is forced along the pathway 400, the highest velocity of the polymeric stream 403 is at the zero-gradient velocity streamline 406. Behind the flow front 404 the velocity of the polymeric stream slows as the flow moves away from the zero-gradient velocity streamline 406 and approaches either polymeric frozen layer 408 near the walls 412 of the pathway 400. The slowest portion of the velocity profile occurs at or near the polymeric frozen layer 408 of the pathway 400. The walls 412 of the pathway 400 form the shape of the molded part.

[0090] FIG. 5 is a plot of the flow velocity at a streamline divided by the average velocity (i.e., dimensionless velocity) as a function of the volume flow ratio for the streamline. As illustrated by the plot, the highest flow velocity occurs at a ratio of 50:50 with the dimensionless flow velocity decreasing as the ratio moves away from 50:50 either toward 0:100 or toward 100:0.

[0091] FIGS. 6-10 depict cross-sectional views of a composite stream flowing along a mold pathway 500 with shifts of an interior core polymeric stream to different desired streamlines due to adjustments of the volumetric flow ratio at different times.

[0092] FIG. 6 depicts a composite stream flowing along a pathway. At time  $T_0$ , the interior core stream 502 is added to the composite stream and flows along a streamline 508 that is slower than the zero gradient velocity streamline 506 with respect to flow front 504. The first portion of the interior core stream flowing along slower streamline 508 is labeled 502a. At time  $T_1$ , the interior core stream 502 begins to shift to a second streamline 510. FIG. 7 shows the composite stream flowing along the pathway 550 after time  $T_1$  including the first portion of the interior core stream 502a produced before  $T_1$  flowing along streamline 508, and a second portion of the interior core stream 502b produced after  $T_1$  as the interior core stream 502 was shifting from slower streamline 508 across the zero gradient velocity streamline 506 to another slower streamline 510. FIG. 8 shows the composite stream

flowing along the pathway 550 after the interior core stream 502 has shifted to slower streamline 510 forming third portion 502c.

[0093] FIGS. 9 and 10 show that, as the flow front 504 continues to advance through the mold cavity pathway 500, the second portion of the interior core stream 502b moves faster than the earlier first portion 502a flowing along the slower streamline 508, and faster than the later third portion 502d flowing along the slower streamline 510, with the part of the second portion 502 on the zero gradient velocity streamline 508 moving the fastest. As the second portion of the interior core stream 502b catches up to the first portion of the interior core stream 502a, the second portion 502b folds over onto itself and forms a cohesion member having an s-shaped dog-leg 512, as shown in FIG. 10.

[0094] To form the cohesion member, the interior core polymeric stream is intentionally shifted from flowing along one streamline at time  $T_0$  to flowing along at least one other streamline at a subsequent time  $T_1$  such that the cohesion member is formed from the interior core stream. In some embodiments, the interior core stream is intentionally shifted multiple times to form the cohesion member from the interior core stream. Shifting the streamline along which the interior core stream flows is achieved by adjusting the volumetric flow ratio of the inner polymeric stream to the outer polymeric stream at desired time points. For example, the volumetric flow ratio of the inner to outer polymeric streams can be adjusted such that the interior core stream, at time  $T_0$ , flows along a first streamline. At time  $T_1$ , the volumetric flow ratio may be adjusted such that the interior core stream is shifted to flow along a second streamline. At time  $T_2$ , the volumetric flow ratio may be adjusted again such that the interior core stream is shifted to flow along a third streamline. One of ordinary skill in the art will understand, from the disclosure provided herein, that the volumetric flow ratio may be adjusted at additional time points as desired to form the desired number and types of cohesion members.

[0095] The shifting of the interior core flow stream can be accomplished with nozzle assemblies having a moveable valve pin, for example, the nozzle assemblies 100 and 200. The movable valve pin may be adjusted at multiple and various time intervals to obtain multiple cohesion members in the resulting plastic article as desired.

[0096] The plastic flow within a pathway of the mold cavity, while making an article, is highly laminar and the local velocity across the part thickness (combined polymeric stream) can be calculated for different conditions (i.e., material, temperature, injection speed, etc.). For instance, polymeric materials forming any of the interior core stream or the inner and outer streams may be selected for a specific viscosity to obtain a desired structural or cosmetic effect. For example, in some embodiments, the viscosity of the interior core flow may be between 100 and 400 Pa-sec.

[0097] As described above in relation to FIGS. 4 and 5, the highest velocity of the combined polymeric stream is at the 50:50 streamline with decreasing velocities for streamlines closer to the pathway walls. By placing the interior core stream at different streamline positions across the velocity profile, at different times, the velocities of various portions of the interior core stream can be adjusted, thereby controlling the final configuration of one or more resulting cohesion members. The flow thickness of the interior core stream may also be selected for desired width and thickness of the interior core/barrier layer in the resulting molded plastic article. For

example, in some embodiments, the thickness of the interior core stream along the molded article cavity pathway, or the thickness of the resulting interior core layer in the molded part is about 10 microns to about 100 microns.

[0098] FIG. 11 is a cross-sectional view of an exemplary resulting plastic article 600 having an interior core layer 602 that forms multiple cohesion members 604A, 604B, 604C and 604D that structurally interlock with a skin 606 of the plastic article 600. Although this exemplary embodiment depicts cohesion members 604A, 604B, 604C, 604D that protrude into an inner layer 606a of the skin, other embodiments may have other configurations. For example, protrusions or other cohesion members may be formed on either side, or on both sides, of the interior core stream 602 (either the inner layer 606a, the outer layer 606b or both) and at various time points corresponding to various positions of the cohesion member(s) in the resulting article. The cohesion members may have single-, double-, triple- or otherwise multiple dog-leg configurations. A particular plastic article may have multiple protrusions or multiple single-, double-, triple- or otherwise multiple dog-leg configurations throughout the plastic article as desired.

[0099] In some embodiments, an interior core stream flowing along the zero gradient velocity streamline may be shifted away from the zero gradient velocity streamline. In this example, the shift away from the zero gradient velocity streamline is referred to as the first shift merely for identification and does not imply that the interior core stream had no prior shifts. Because the zero gradient velocity streamline is the fastest streamline, any shift away from the zero gradient velocity streamline will place the subsequent flow of the interior core layer along a slower streamline. The interior core stream may be intentionally shifted again to form the cohesion member. The second shift may be to a faster streamline or to a slower streamline than the first shift. For example, the second shift may be back to the original zero gradient velocity streamline.

[0100] In other embodiments, the interior core stream may be flowing along a streamline other than the zero gradient velocity streamline when the initial shift occurs. The volumetric flow ratio of the inner and outer streams can be adjusted to shift the interior core stream to a faster or slower streamline on the same side, or on the opposite side of the zero gradient velocity streamline. Further shifts may be made to faster or slower streamlines, which may lie on the same side or on the opposite side of the zero gradient velocity streamline. For example, when the interior core stream is shifted from a first streamline, on one side of the zero gradient velocity streamline, to the opposite side of the zero gradient velocity streamline, the portion of the interior core stream that flows along the zero gradient velocity streamline or close to the zero gradient velocity streamline catches up to the earlier, leading portion of the interior core stream that is flowing along the slower streamline. This causes the portion of the interior core stream flowing along or near the zero gradient velocity streamline to overlap the earlier, leading portion of the interior core stream, thereby creating the cohesion member. As another example, shifting the interior core stream from a first streamline to a second faster streamline, either across the zero gradient velocity stream or on the same side of the zero gradient velocity stream, allows the portion of interior core stream lying on the second faster streamline to at least partially catch up to the earlier, leading portion of the interior core stream flowing along the slower streamline

thereby creating the cohesion member. The cohesion member secures the interior core layer to the skin thereby increasing the adhesion of the interior core layer and the skin, preventing, or reducing a risk of, delamination, thereby reducing or eliminating the need for incorporating adhesives into the process of preparing the molded plastic article.

[0101] The physical dimensions of a cohesion member are affected by many factors, which include, but are not limited to: the lateral separation between a pre-shift streamline and a post-shift streamline, the time interval between shifts, the time interval over which the shift is made, and a distance the cohesion member portion of the interior core flows from the nozzle to a position in the resulting article.

[0102] The width (W) of the cohesion member can be adjusted as by increasing or decreasing the lateral separation of the before-shift streamline and the after-shift streamline of the interior core stream. For example, a shift of the interior core stream from an 80:20 streamline to a 20:80 streamline would make a relatively wide, or relatively broad, cohesion member as compared to one made by shifting the interior core stream from a 60:40 streamline to a 40:60. As another example, shifting from a 40:60 streamline to a 70:30 would make a relatively wide, or relatively broad, cohesion member as compared to one made by shifting the interior core stream to shifting from a 40:60 streamline to a 55:45 streamline. As another example, a cohesion member created by shifting the interior core stream from the 60:40 streamline to the zero gradient velocity streamline would be narrower than a cohesion member created by shifting the 60:40 streamline to the 40:60 streamline.

[0103] The length (L) of the cohesion member can be adjusted by increasing or decreasing the time interval between each shift. For example a narrow cohesion member can be created by shifting the interior core stream from the zero gradient velocity streamline to the 40:60 streamline. A longer cohesion member can be created by allowing the interior core, after any shift, to flow along the desired streamline for a longer period of time while a shorter cohesion member can be created by allowing the interior core, after any shift, to flow along the desired streamline for a shorter period of time.

[0104] FIG. 12 depicts an exemplary dog-leg cohesion member 700 created by shifting an interior core stream from a first slow streamline 704, across the zero gradient velocity streamline 706, and to a second slow streamline 708 during injection molding. The resulting article has a first portion of an interior core layer 702a formed from a first interior core stream portion flowing along the first streamline 704, a second portion of the interior core layer 702b formed from a second interior core stream portion flowing along streamlines between the first slow streamline 704 and the second slow streamline 708, and a third portion of the interior core layer 702c formed from a third interior core stream portion flowing along the third streamline 704. The separation between the first slow streamline 704 and the second slow streamline 708 determines the width (W) of the cohesion member 700. In this example, the length (L) of the single dog-leg cohesion member in the resulting article is based, at least in part, on the distance that the second interior core stream portion flowed along the path from the nozzle to its position in the final article.

[0105] In a resulting article, a force between an interior core layer and skin layers is increased for a dog-leg cohesion member having a characteristic length of the same magnitude, or less than, the local thickness, thereby increasing

cohesion and increasing the resistance of the molded plastic article to delamination. For example, in FIG. 12 the characteristic length (L) of the dog-leg cohesion member is about the same magnitude as the local thickness (T) at the cohesion member.

[0106] In some embodiments, an interior core stream is shifted across the zero gradient velocity streamline more than once to create a cohesion member having double dog-leg configuration.

[0107] FIG. 13 depicts an exemplary cohesion member 800 having a double dog-leg configuration. At time  $T_0$ , an interior core stream 802 is traveling along a streamline 804 that is slower than the zero-gradient velocity streamline 806 forming a first interior core stream portion 802a. At time  $T_1$ , the interior core stream 802, is shifted across the zero gradient velocity streamline 806 to another streamline 808 forming a second interior core stream portion 802b, where it is allowed to flow for a desired time interval from  $T_1$  to  $T_2$ , forming a third interior core stream portion 802c. At time  $T_2$ , the interior core stream 802 is again shifted across the zero gradient velocity streamline 806 to the same streamline 804 as at time  $T_0$ , or near the same streamline as the streamline at time  $T_0$ , forming a fourth interior core stream portion 802d, and allowed to continue flowing on this streamline 804 forming a fifth interior core stream portion 802e. This double-shift across the zero gradient velocity streamline 806 forms the cohesion member 800 having a double dog-leg configuration.

[0108] Some exemplary methods and systems include controlling the volumetric flow ratio of the inner and outer streams to create the cohesion member. In the exemplary nozzle assemblies depicted in FIGS. 1 and 2, valve pins 102 and 202, respectively, are adjusted toward or away from a nozzle egress port to control the volumetric flow rate of the inner and outer polymeric material streams in the combined polymeric stream during ejection of the combined polymeric stream from the nozzle into the mold cavity. In controlling the volumetric flow rates of the inner and outer streams, the volumetric flow ratio is adjusted such that the interior core stream is shifted to desired streamlines within the combined polymeric stream. For example, by adjusting the position of the valve pin based on a desired volumetric flow ratio and placement of the interior core stream, the interior core stream can be placed at a first streamline at time  $T_0$ , and at a later time  $T_1$  shifted to a second streamline. At time  $T_2$ , subsequent to time  $T_1$ , the streamline of the interior core can again be shifted to a third streamline by adjusting the valve pin based on the new desired volumetric flow ratio. Further adjustments are likewise possible at additional time points to create one or more additional cohesion member(s) from the interior core as desired.

### III. Examples

[0109] The following illustrations are provided as non-limiting examples of how to intentionally form different types of cohesion members.

[0110] In some exemplary embodiments, an interior core stream is adjusted from a first streamline across the zero-gradient velocity streamline to a second streamline, and then adjusted back across the zero-gradient velocity streamline to a third streamline, thereby forming a double dog-leg shaped cohesion member (e.g., see FIG. 13). Controlling the interior core stream may include adjusting the volumetric flow ratio of the inner to outer streams by adjusting the valve pin in the nozzle to obtain a first volumetric flow ratio that places the

interior core stream at a first streamline away from the zero-gradient velocity streamline at time  $T_0$ , and adjusting the valve pin at time  $T_1$  to obtain a second volumetric flow ratio that places the interior core stream at a second streamline that is across the zero-gradient velocity (50:50) streamline from the first streamline. At a later time  $T_2$ , the valve pin is further adjusted to obtain a third volumetric flow ratio that shifts the interior core stream back across the zero-gradient velocity streamline to a third streamline, which may be the same as or different from the first streamline. As explained above with respect to FIG. 12, shifting the interior core stream from a slower streamline across the zero gradient velocity streamline to a different streamline, and then back across the zero gradient velocity streamline to a slower streamline forms a cohesion member having a double dog-leg configuration.

[0111] For example, the interior core stream may be shifted from the 80:20 streamline to the 20:80 streamline, and then back to the 80:20 streamline. In another example, the first streamline may be one of the 20:80, 25:75, and 40:60 streamlines, the second streamline may be one of the 60:40, 75:25, and 20:80 streamlines, and the third streamline may be one of the 20:80, 25:75, and 40:60 streamlines. In another example, the first streamline may be one of the 60:40, 75:25, and 20:80 streamlines, the second streamline may be one of the 20:80, 25:75, and 40:60 streamlines, and the third streamline may be one of the 60:40, 75:25, and 20:80 streamlines. Other exemplary volumetric flow ratios may be employed in which the second streamline is across the zero-gradient velocity streamline from the first streamline and from the third streamline. Those skilled in the art will readily appreciate that the specific exemplary details are only illustrative and are not meant to limit the invention as described herein, which is defined by the claims which follow thereafter.

[0112] The volumetric flow ratios described herein are illustrative and one of ordinary skill in the art will appreciate that other volumetric flow ratios are possible. For example, the flow ratios may vary incrementally from about 5:95 to about 95:5 and may include all increments within that range.

[0113] It should be noted that the size of the adjustment of the volumetric ratio may depend on which phase of molding is occurring during adjustment. For example, the adjustment of the volumetric ratio may be less than 30:70 or greater than 70:30 during the filling phase to create a cohesion member. It should also be noted that 60:40 or 40:60 streamline during the filling phase becomes the 80:20 or 20:80 streamline during the packing phase due to the thickness of frozen polymeric material on the walls of the mold cavity during the packing phase. A cohesion member may be formed in either or both of the filling phase and the packing phase.

[0114] In some exemplary embodiments, an interior core stream is adjusted from a first streamline to a faster second streamline without crossing the zero-gradient velocity streamline, and then adjusted to a slower third streamline without crossing the zero gradient velocity stream, thereby forming a double dog-leg shaped cohesion member. In some embodiments, the interior core stream is placed at a first streamline at time  $T_0$ , and then at time  $T_1$ , the volumetric flow ratio is adjusted by adjusting the valve pin to shift the interior core stream to a faster second streamline that is not across the zero-gradient velocity streamline from the first streamline. At a later time  $T_2$ , the valve pin is further adjusted to shift the interior core stream to a slower third streamline that is the same as the first streamline, or that lies on the same side of the zero-gradient velocity streamline as the first streamline.

Shifting the interior core stream from a slow first streamline to a faster second streamline at time  $T_1$ , and then shifting the interior core stream to a slower third streamline at a time  $T_2$  without crossing the zero-gradient velocity streamline forms a double dog-leg configuration cohesion member.

**[0115]** For example, the volumetric flow ratio of the inner to outer polymeric streams may be adjusted such that at time  $T_0$ , the volumetric flow ratio is between about 20:80 and about 50:50. At time  $T_1$ , the volumetric flow ratio is adjusted to between about 50:50 and about 80:20. A single dog-leg configuration cohesion member is created from the single shift from a first slower streamline across zero-gradient velocity streamline to a second slower streamline.

**[0116]** For example, shifting the interior core stream from the 20:80 streamline to the 40:60 streamline and then back to the 20:80 streamline creates a double dog-leg cohesion member. As another example, shifting the interior core stream from the 80:20 streamline to the 60:40 streamline and then to the 70:30 streamline creates a double dog-leg cohesion member. As another example, the interior core stream may be shifted from the 70:30 streamline to the 50:50 streamline, and then back to the 70:30 streamline to create a double dog-leg cohesion member.

**[0117]** As another example, an interior core stream flowing along a first streamline that lies in the range of the 20:80 to 40:60 streamlines at  $T_0$ , may be adjusted at time  $T_1$  to flow along a faster second streamline that lies between the first streamline and the zero-gradient velocity streamline or on the zero-gradient velocity streamline. At a time  $T_2$ , the interior core stream may be adjusted to flow along a third streamline that lies between the second streamline and the 20:80 streamline, thereby forming a double dog-leg cohesion member in the resulting article.

**[0118]** As another example, an interior core stream flowing along a first streamline that lies in the range of the 80:20 to 60:40 streamlines at  $T_0$ , may be adjusted at time  $T_1$  to flow along a faster second streamline that lies between the first streamline and the zero-gradient velocity streamline or on the zero-gradient velocity streamline. At a time  $T_2$ , the interior core stream may be adjusted to flow along a third streamline that lies between the second streamline and the 80:20 streamline, thereby forming a double dog-leg cohesion member in the resulting article. Other exemplary volumetric flow ratios may be employed to create a double dog-leg configuration cohesion member by shifting the interior core stream from a slow streamline to a faster streamline and back to a slower streamline without crossing the zero-gradient velocity gradient (the 50:50) streamline. Those skilled in the art will readily appreciate that the specific exemplary details are only illustrative and are not meant to limit the invention as described herein, which is defined by the claims.

**[0119]** In some embodiments, such as that depicted in FIG. 3, the interior core stream is flowing along the 50:50 streamline at time  $T_0$  and is subsequently adjusted to a slower streamline at time  $T_1$  then adjusted back to the 50:50 streamline at time  $T_2$ . A cohesion member with a protrusion configuration is formed in this manner.

**[0120]** In some embodiments, where the volumetric flow ratio at time  $T_0$  is about 50:50, the volumetric flow ratio is adjusted at time  $T_1$  to a volumetric flow ratio that is less than about 50:50 such that the interior core stream is biased towards the inner polymeric stream and at time  $T_2$  the volumetric flow ratio is adjusted to be between about 50:50 and the volumetric flow ratio at time  $T_1$ .

**[0121]** In some embodiments, where the volumetric flow ratio at time  $T_0$  is about 50:50, the volumetric flow ratio is adjusted at time  $T_1$  to a volumetric flow ratio that is greater than about 50:50 such that the interior core stream is biased towards the outer polymeric stream and at time  $T_2$  the volumetric flow ratio is adjusted to be between about 50:50 and the volumetric flow ratio at time  $T_1$ .

**[0122]** In some exemplary embodiments, a single dog-leg cohesion member is formed by shifting an interior core stream from a first streamline, across the zero gradient velocity gradient to a second streamline (e.g., see FIG. 12). For example, at time  $T_0$ , the interior core stream is flowing along a first streamline in which the volumetric flow ratio is between about 20:80 and about 80:20. At time  $T_1$ , the volumetric flow ratio is adjusted by adjusting the valve pin to shift the interior core stream to a second streamline across the zero-gradient velocity streamline from the first streamline, thereby forming a single dog-leg configuration cohesion member. Shifting the interior core stream from a slow streamline across a faster streamline to another slow streamline forms a single dog-leg configuration cohesion member. As another example, shifting the interior core stream from a first streamline, which lies between about the 20:80 and 80:20 streamlines, across the zero-gradient velocity streamline to a second streamline, which lies between about the 80:20 and 20:80 streamlines, creates a single dog-leg cohesion member. Other exemplary volumetric flow ratios may be employed to create a single dog-leg configuration cohesion member by shifting the interior core stream from a first streamline across a faster streamline (e.g., the zero-gradient velocity streamline) to a second streamline slower than the faster streamline. Those skilled in the art will readily appreciate that the specific exemplary details are only illustrative and are not meant to limit the invention as described herein, which is defined by the claims which follow thereafter.

**[0123]** The timing of the adjustments in volumetric flow ratio may be selected as desired to obtain the desired effect. In certain embodiments, the time between  $T_0$  and  $T_1$ , for example is between about 10 to 100 milliseconds and between  $T_1$  and  $T_2$  is between about 10 and 100 milliseconds.

**[0124]** In certain other aspects, the exemplary methods and systems described herein form a cosmetic effect in the resulting plastic article. For example, in certain embodiments, the polymeric material which forms the interior core stream may be adjusted to have a desired color (e.g., white) or texture in the resulting plastic article. The color of the polymeric material may be adjusted by adding various colors or texture adjusting materials. In some embodiments, color is red, blue, yellow, green or any mixture thereof. The inner and outer layers may likewise be adjusted to achieve the desired cosmetic effect. In certain embodiments, the interior core layer is visually distinguishable from the inner and outer layers of the skin.

**[0125]** The cosmetic effect is formed by the interlocking effect of the cohesion member with the skin and also by the texture and color of the interior core stream and the inner and outer layers.

**[0126]** Those skilled in the art will readily appreciate that the specific exemplary details are only illustrative and are not meant to limit the invention as described herein, which is defined by the claims which follow thereafter.

**[0127]** FIG. 14 illustrates an exemplary computing environment suitable for practicing exemplary embodiments taught herein. The environment may include a co-injection



control device **900** coupled, wired, wirelessly or a hybrid of wired and wirelessly, to co-injection system **1400**. The co-injection control device **900** is programmable to implement executable Cohesion Member Code **950** for forming a cohesion member as taught herein. Co-injection control device **900** includes one or more computer-readable media for storing one or more computer-executable instructions or software for implementing exemplary embodiments. The computer-readable media may include, but are not limited to, one or more types of hardware memory, non-transitory tangible media, etc. For example, memory **906** included in the co-injection control device **900** may store computer-executable instructions or software, e.g., instructions for implementing and processing every module of the executable Flow Control Code **950**. Co-injection control device **900** also includes processor **902** and, one or more processor(s) **902'** for executing software stored in the memory **906**, and other programs for controlling system hardware. Processor **902** and processor(s) **902'** each can be a single core processor or multiple core (**904** and **904'**) processor.

[0128] Virtualization may be employed in co-injection control device **900** so that infrastructure and resources in the computing device can be shared dynamically. Virtualized processors may also be used with the executable Cohesion Member Code **950** and other software in storage **916**. A virtual machine **914** may be provided to handle a process running on multiple processors so that the process appears to be using only one computing resource rather than multiple. Multiple virtual machines can also be used with one processor.

[0129] Memory **906** may comprise a computer system memory or random access memory, such as DRAM, SRAM, EDO RAM, etc. Memory **906** may comprise other types of memory as well, or combinations thereof.

[0130] A user may interact with co-injection control device **900** through a visual display device **922**, such as a computer monitor, which may display the user interfaces **924** or any other interface. The visual display device **922** may also display other aspects or elements of exemplary embodiments, e.g. the databases, the enrollment forms, the medication guide, etc. Co-injection control device **900** may include other I/O devices such a keyboard or a multi-point touch interface **908** and a pointing device **910**, for example a mouse, for receiving input from a user. The keyboard **908** and the pointing device **910** may be connected to the visual display device **922**. Co-injection control device **900** may include other suitable conventional I/O peripherals. Co-injection control device **900** may further comprise a storage device **916**, such as a hard-drive, CD-ROM, or other non-transitory computer readable media, for storing an operating system **918** and other related software, and for storing executable Cohesion Member Code **950**.

[0131] Co-injection control device **900** may include a network interface **912** to interface to a Local Area Network (LAN), Wide Area Network (WAN) or the Internet through a variety of connections including, but not limited to, standard telephone lines, LAN or WAN links (e.g., 802.11, T1, T3, 56 kb, X.25), broadband connections (e.g., ISDN, Frame Relay, ATM), wireless connections, controller area network (CAN), or some combination of any or all of the above. The network interface **912** may comprise a built-in network adapter, network interface card, PCMCIA network card, card bus network adapter, wireless network adapter, USB network adapter, modem or any other device suitable for interfacing

authorization computing device **900** to any type of network capable of communication and performing the operations described herein. Moreover, co-injection control device **900** may be any computer system such as a workstation, desktop computer, server, laptop, handheld computer or other form of computing or telecommunications device that is capable of communication and that has sufficient processor power and memory capacity to perform the operations described herein.

[0132] Co-injection control device **900** can be running any operating system such as any of the versions of the Microsoft® Windows® operating systems, the different releases of the Unix and Linux operating systems, any version of the MacOS® for Macintosh computers, any embedded operating system, any real-time operating system, any open source operating system, any proprietary operating system, any operating systems for mobile computing devices, or any other operating system capable of running on the computing device and performing the operations described herein. The operating system may be running in native mode or emulated mode.

[0133] Cohesion Member Code **950** includes executable code executable by the processor **902** to control the co-injection system **1400** to selectively control a volumetric flow volume of the inner and outer polymeric streams, control a position of the interior core stream relative to a velocity flow front of the combined polymeric stream and control extrusion start time of the interior core stream relative to the extrusion start time of the inner and outer polymeric streams as taught herein. That is, Cohesion Member Code **950** includes executable code executable by the processor **902** to control the co-injection system **1400** to selectively form one or more cohesion members to adhere the interior core layer of the resulting molded plastic article with the inner layer or outer layer of the resulting molded plastic article without adhesive. In some embodiments, execution of the Cohesion Member Code **950** by the processor **902** allows the co-injection system **1400** to intentionally shift the interior core stream between various flow streams during injection to form one or more cohesion members. Methods and co-injection systems taught herein facilitate the co-injection molding of plastic articles (e.g., food or beverage containers) whereby the interior core stream forms a structural element that secures the interior core layer to the inner layer and/or the outer layer to prevent delamination of the resulting molded plastic article. Further, the formation of the cohesion member can create visual effects in the resulting molded plastic article. Formation of the cohesion member may reduce or eliminate the need for adhesive compounded into the polymeric materials used to form the resulting molded plastic article.

[0134] FIG. 15 depicts a cross-sectional view of a portion of an exemplary plastic article **1000** having an interior core layer **1002** with a cohesion member **1010**. The cohesion member **1010** has a single dog-leg configuration formed from a single adjustment of the volumetric flow ratio that shifted the interior core stream from a slower first streamline **1004** across the zero-gradient velocity streamline **1006** to a faster second streamline **1008** located closer to the zero-gradient velocity streamline **1006**. The portion of the interior core stream traveling along the faster streamlines between the first streamline **1004** and the second streamline **1008**, and a leading portion of the interior core stream traveling along the second streamline **1008**, caught up to the portion of the inte-

rior core stream travelling along the slower streamline **1004** and overlapped to form the cohesion member **1010** with the single dog-leg configuration.

[0135] FIG. 16 illustrates a cross-sectional view of a resulting plastic article formed as a container **1100** from the systems and methods described herein. Although, container **1100** includes an interior core **1102** with six cohesion members, in other embodiments, the container **1100** can be formed with any number of cohesion members dependent on the size of the container. For example, a container can have one cohesion member, two cohesion members, three cohesion members, four cohesion members, five cohesion members or more. Further, a container may include only one type of cohesion member or multiple different types of cohesion members. As illustrated by FIG. 16, exemplary cohesion members formable in the container **1100** include, but are not limited to, a double dog-leg configured cohesion member **1104A**, a protrusion configured cohesion member **1104B**, and a single dog-leg configured cohesion member **1104C**. Each the cohesion members **1104A**, **1104B** and **1104C** secures the interior core **1102** to the inner layer **1106** or to the outer layer **1108** to prevent or reduce the occurrence of delamination, and to reduce or eliminate the need for adhesives compounded into the polymeric material forming the interior core and/or the skin.

[0136] FIG. 17 illustrates a cross-sectional view of a resulting plastic article formed as a covering mechanism **1200**, such as, for example, a bottle cap or other closure device for covering or closing an opening in a container. Covering mechanism **1200** includes an interior core layer **1202** with several cohesion members, such as, for example, a protrusion configured cohesion member **1204A** and a double dog-leg configured cohesion member **1204B**. The cohesion members such as for example **1204A** and **1204B** secure the interior core layer **1202** to the inner layer **1206** and/or to the outer layer **1208** of the covering mechanism **1200** to prevent delamination with a reduced, or eliminated need for adhesives in the materials of the interior core layer, the inner layer and/or the outer layer.

[0137] FIG. 18 schematically illustrates an exemplary flow chart of steps involved in forming a plastic article having one or more cohesion members. In step (1) A combined polymeric stream is ejected from the egress port of a nozzle assembly to the gate portion of a mold cavity. (2) The combined polymeric stream is forced along the annular pathways of the mold cavity. (3) As the combined polymeric stream is forced along the annular pathways of the mold cavity, the volumetric flow rate of the inner to outer polymeric streams is adjusted to have a desired polymeric flow ratio such that the interior core stream can be shifted to flow along a desired streamline of the annular pathways. (4) At time  $T_0$ , the interior core stream flows along a first streamline. At time  $T_1$ , the volumetric flow ratio is adjusted such that the interior core stream flows along a second streamline to create a cohesion member having a protrusion configuration.

[0138] Alternatively, (5b') at time  $T_2$ , the volumetric flow ratio is adjusted again such that the interior core stream is shifted to flow along a third streamline to create a cohesion member having a dog-leg, or protrusion configuration. Either alternatives may be repeated (6) individually or in combination to form multiple protrusions and/or dog-leg cohesion members. The resulting plastic article is produced (7) having

at least one cohesion member having a single or multiple protrusion, single dog-leg, double dog-leg or other configurations.

[0139] FIG. 19 schematically depicts a method **1300** of co-injection molding a multilayer plastic article having a plurality of cohesion members, in accordance with some embodiments. In method **1300**, a combined polymeric stream is formed in an injection nozzle (step **1310**). The combined stream includes an interior core stream of a first polymeric material encased by an inner stream of a second polymeric material and an annular outer stream of the second polymeric material. The combined stream is injected into a mold cavity (step **1320**). During injection of the combined stream into the mold cavity, the volumetric flow ratio of the inner stream to the outer stream is adjusted to intentionally form the cohesion member from the interior core stream (step **1330**). The resulting cohesion member structurally interlocks an interior core layer with an inner skin layer, with an outer skin layer or with both in the resulting article.

[0140] FIG. 20 schematically depicts steps that may be included in adjusting the volumetric flow ratio, in accordance with some embodiments. A valve pin may be adjusted at a time  $T_1$  to intentionally shift the interior core stream from flowing along a first streamline with a volumetric flow ratio between about 5:95 and about 95:5 across a streamline at a zero-gradient of a velocity profile of a flow front of the combined polymeric plastic stream (the zero-gradient of velocity streamline) to flowing along a second streamline (step **1332**). In some embodiments, intentionally adjusting the volumetric flow ratio further includes adjusting the valve pin at a later time  $T_2$  to shift the interior core stream from flowing along the second streamline to flowing along a third streamline (step **1334**).

[0141] FIG. 21 schematically depicts alternative steps that may be included in adjusting the volumetric flow ratio, in accordance with some embodiments. A valve pin may be adjusted at a time  $T_1$  to intentionally shift the interior core stream from flowing along a first streamline with a volumetric flow ratio between about 5:95 and about 95:5 to flowing along a second streamline that has a velocity greater than the first streamline without crossing the zero-gradient velocity streamline (step **1336**). In some embodiments, intentionally adjusting the volumetric flow ratio further includes adjusting the valve pin at a later time  $T_2$  to intentionally shift the interior core stream from flowing along the second streamline to flowing along a third streamline (step **1338**).

[0142] In some embodiments, the time interval between time  $T_1$  and time  $T_2$  is between about 5 milliseconds and about 50 milliseconds. In some embodiments, the third streamline is across the zero-gradient velocity streamline from the second streamline and the second streamline is away from the zero-gradient velocity streamline. The velocity along the third streamline may be less than the velocity along the second streamline. In some embodiments, the third streamline is the same as the first streamline.

[0143] FIG. 22 illustrates an exemplary system suitable for practicing the present invention. Co-injection molding system **1400** is configured to inject at least two materials into a mold cavity. Materials suitable for use with the present invention include polymer based materials such as, polyethylene, PET, PEN, PP, EVOH, nylon, COCs, HDPE and polycarbonates. Co-injection molding system **1400** includes a first material source **1402**, a second material source **1404**, and a manifold **1406**. Co-injection molding system **1400** further

includes nozzle assemblies **18A-18D** and mold **2400**. Mold **24** includes gates **20A-20D**, and cavities **22A-22D**.

**[0144]** A first polymeric material is extruded from the first material source **1402** and a second polymeric material is extruded from the second material source **1404** into the manifold **1406** for combining in nozzles **18A-18D** before being injected into mold cavities **22A-22D**. The first and second polymeric streams are combined to form an annular combined polymeric stream such that the first polymeric material forms an interior core stream in the combined polymeric stream while the second polymeric material forms the inner and outer streams in the combined stream. The inner and outer streams encase the interior core stream as the annular combined polymeric stream is injected from the nozzle.

#### IV. Equivalents:

**[0145]** Those skilled in the art will recognize, or be able to ascertain using no more than routine experimentation, many equivalents to the specific embodiments of the invention described herein. Such equivalents are intended to be encompassed by the following claims. All figures are offered by way of illustration, not by way of limitation. While specific examples have been provided, the descriptions are illustrative and not restrictive. Any one or more of the features of the previously described embodiments can be combined in any manner with one or more features of any other embodiments in the present disclosure. Furthermore, many variations of the present disclosure will become apparent to those skilled in the art upon review of this disclosure.

1. A method of co-extruding a plurality of polymeric plastic material streams to produce a resulting molded plastic article, the method comprising the steps of:

forming a combined polymeric plastic stream in an injection nozzle, the combined stream comprising an interior core stream of a first polymeric material encased by an inner stream of a second polymeric material and an outer stream of the second polymeric material;

injecting the combined stream into a mold cavity; and adjusting a volumetric flow ratio of the inner stream to the outer stream during injection of the combined stream into the mold cavity to intentionally form a cohesion member from the interior core stream with an inner layer of the resulting molded plastic article formed from the inner stream, with an outer layer of the resulting molded plastic article formed from the outer stream, or with both.

2. The method of claim 1, wherein adjusting the volumetric flow ratio of the inner stream to the outer stream during injection of the combined stream into the mold cavity to intentionally form the cohesion member comprises:

adjusting a valve pin at a time  $T_1$  to shift the interior core stream from flowing along a first streamline with a volumetric flow ratio between about 5:95 and about 95:5 across a streamline at a zero-gradient of a velocity profile of a flow front of the combined polymeric plastic stream (the zero-gradient of velocity streamline) to flowing along a second streamline.

3. The method of claim 1, wherein adjusting the volumetric flow ratio of the inner stream to the outer stream during injection of the combined stream into the mold cavity to intentionally form the cohesion member from the interior core stream comprises:

adjusting a valve pin at a time  $T_1$  to shift the interior core stream from flowing along a first streamline with a volumetric flow ratio between about 5:95 and about 95:5 to flowing along a second streamline without crossing a streamline at the zero-gradient of a velocity profile of a flow front of the combined polymeric plastic stream (the zero-gradient of velocity streamline), wherein a velocity at the second streamline is greater than a velocity at the first streamline.

4. The method of claim 3, wherein the second streamline is the zero-gradient of velocity of streamline.

5. The method of claim 2, wherein adjusting the volumetric flow ratio of the inner stream to the outer stream during injection of the combined stream into the mold cavity to intentionally form the cohesion member from the interior core stream further comprises:

adjusting the valve pin at a time  $T_2$  later than time  $T_1$  to shift the interior core stream from flowing along the second streamline to flowing along a third streamline.

6. The method of claim 5, wherein the time interval between  $T_2$  and  $T_1$  is between about 5 milliseconds and about 50 milliseconds.

7. The method of claim 5, wherein the third streamline is across the zero-gradient of velocity streamline from the second streamline and the second streamline is away from the zero-gradient velocity streamline.

8. The method of claim 5, wherein the velocity along the third streamline is less than the velocity along the second streamline.

9. The method of claim 5, wherein the third streamline is the same as the first streamline.

10. The method of claim 1, wherein a magnitude of a length (L) of the cohesion member is the same as or less than a magnitude of a local thickness (T) of the resulting article at the cohesion member.

11. The method of claim 1, wherein the first polymeric material comprises ethyl vinyl alcohol (EVOH) and the second polymeric material comprises polypropylene.

12. The method of claim 1, wherein the viscosity of the interior core stream falls in the range of 40-400 Pa-sec.

13. The method of claim 1, wherein a cosmetic effect is formed in the resulting molded plastic article by the shifting of the interior core stream.

14. The method of claim 1, wherein a color of the interior core stream is visually distinguishable in the resulting molded plastic article.

15. The method of claim 1, wherein the first polymeric material and the second polymeric material are substantially free of adhesive.

16. The method of claim 1, wherein the cohesion member is formed during a filling phase of a molding cycle.

17. The method of claim 1, wherein the cohesion member is formed during a packing phase of a molding cycle.

18. The method of claim 1, wherein the cohesion member is formed during a filling phase and a packing phase of a molding cycle.

19. A co-injection molded multi-layer plastic article comprising:

an inner layer comprising a first polymeric material; an outer layer comprising the first polymeric material; and an interior core layer comprising a second polymeric material, disposed between the inner layer and the outer layer, and configured to intentionally form a cohesion member

structurally interlocking the interior layer to the inner layer, to the outer layer, or to both.

**20.** The molded plastic article of claim **19**, wherein the molded plastic article is an article suitable for use as a closure.

**21.** The molded plastic article of claim **19**, wherein the molded plastic article is an article suitable for use as a container.

**22.** The molded plastic article of claim **19**, wherein a magnitude of a length (L) of the cohesion member is the same as or less than a magnitude of a local thickness (T) of the molded plastic article at the cohesion member.

**23.** The molded plastic article of claim **19**, wherein none of the interior core layer, the inner layer and the outer layer includes a compounded adhesive.

**24.** The molded plastic article of claim **19**, wherein the cohesion member comprises a first segment of the interior core layer overlapping a second segment of the interior core layer within a thickness of the article.

**25.** A system for forming a multi-layer molded plastic article having a cohesion member, the system comprising:

a mold having a plurality of cavities to mold a plurality of multi-layered plastic articles;

a first material source to supply a first polymeric material for use in forming at least one layer of each of the plurality of multi-layered plastic articles;

a second material source to supply a second polymeric material for use in forming at least one layer of each of the plurality of multi-layered plastic articles;

a plurality of nozzles in communication with a portion of the mold to inject the first and second polymeric materials into each of the plurality of cavities, each nozzle configured to intentionally form a composite stream including an inner stream comprising a first material, an annular outer stream comprising the first material, and an annular interior core stream comprising a second material between the inner stream and the outer stream, each nozzle is further configured for adjustment of a volumetric ratio of the of the inner stream to the outer stream in the composite stream flow ejected from the nozzle;

a first set of flow channels configured to distribute the first polymeric material from the first material source to each of the plurality of nozzles;

a second set of flow channels configured to distribute the second polymeric material from the second material source to each of the plurality of nozzles; and

a processor programmed to, during ejection of the composite streams from the nozzles into the plurality of cavities, adjust a volumetric ratio of the inner stream to the outer stream in the composite stream flow ejected from the nozzle, to intentionally form the cohesion member from the interior core stream that structurally interlocks an interior layer of the resulting molded plastic article formed from the interior core stream with an inner layer of the resulting molded plastic article formed from the inner stream, with an outer layer of the resulting molded plastic article formed from the outer stream, or with both.

**26.** The system of claim **25**, wherein the processor is further programmed to control a position of a valve pin in each of the plurality of nozzles to control the volumetric ratio of the inner flow stream to the outer flow stream.

**27.** The system of claim **25**, wherein the cohesion member is formed during a filling phase of a molding cycle.

**28.** The system of claim **25**, wherein the cohesion member is formed during a packing phase of a molding cycle.

**29.** The system of claim **25**, wherein inner layer, the outer layer and the interior layer are substantially free of a compounded adhesive.

**30.** A computer-readable medium storing computer executable instructions for co-extruding a plurality of polymeric plastic material streams to produce a resulting multi-layer molded plastic article having a cohesion member, the instructions comprising instructions for:

forming a combined polymeric plastic stream in an injection nozzle, the combined stream comprising an interior core stream of a first polymeric material encased by an inner stream of a second polymeric material and an outer stream of the second polymeric material;

injecting the combined stream into a mold cavity; and

adjusting a volumetric flow ratio of the inner stream to the outer stream during injection of the combined stream into the mold cavity to intentionally form a cohesion member from the interior core stream that structurally interlocks an interior layer of the resulting molded plastic article formed from the interior core stream with an inner layer of the resulting molded plastic article formed from the inner stream, with an outer layer of the resulting molded plastic article formed from the outer stream, or with both.

**31.** The computer-readable medium of claim **30**, wherein adjusting the volumetric flow ratio of the inner stream to the outer stream during injection of the combined stream into the mold cavity to intentionally form the cohesion member comprises:

adjusting a valve pin at a time  $T_1$  to shift the interior core stream from flowing along a first streamline with a volumetric flow ratio between about 5:95 and about 95:5 across a streamline at a zero-gradient of a velocity profile of a flow front of the combined polymeric plastic stream (the zero-gradient of velocity streamline) to flowing along a second streamline.

**32.** The computer-readable medium of claim **31**, wherein adjusting the volumetric flow ratio of the inner stream to the outer stream during injection of the combined stream into the mold cavity to intentionally form the cohesion member from the interior core stream further comprises:

adjusting the valve pin at a time  $T_2$  later than time  $T_1$  to shift the interior core stream from flowing along the second streamline to flowing along a third streamline.

**33.** The computer-readable medium of claim **32**, wherein the time interval between  $T_2$  and  $T_1$  is between about 5 milliseconds and about 50 milliseconds.

**34.** The computer-readable medium of claim **30**, wherein a magnitude of a length (L) of the cohesion member is the same as or less than a magnitude of a local thickness (T) of the resulting article at the cohesion member.

**35.** The computer-readable medium of claim **30**, wherein adjusting the volumetric flow ratio of the inner stream to the outer stream during injection of the combined stream into the mold cavity to intentionally form the cohesion member from the interior core stream comprises:

adjusting a valve pin at a time  $T_1$  to shift the interior core stream from flowing along a first streamline with a volumetric flow ratio between about 5:95 and about 95:5 to flowing along a second streamline without crossing a streamline at the zero-gradient of a velocity profile of a flow front of the combined polymeric plastic stream (the

zero-gradient of velocity streamline), wherein a velocity at the second streamline is greater than a velocity at the first streamline.

**36.** The computer-readable medium of claim **35**, wherein the second streamline is the zero-gradient of velocity streamline.

\* \* \* \* \*