

(12) PATENT
(19) AUSTRALIAN PATENT OFFICE

(11) Application No. AU 199874258 B2
(10) Patent No. 726169

(54) Title
An ostomy appliance

(51)⁶ International Patent Classification(s)
A61F 005/445 A61F 005/443

(21) Application No: 199874258 (22) Application Date: 1998.05.25

(87) WIPO No: W098/53771

(30) Priority Data

(31) Number	(32) Date	(33) Country
0598/97	1997.05.26	DK
1507/97	1997.12.22	DK

(43) Publication Date : 1998.12.30
(43) Publication Journal Date : 1999.02.11
(44) Accepted Journal Date : 2000.11.02

(71) Applicant(s)
Coloplast A/S

(72) Inventor(s)
Inger Mann Nielsen; Eskil Højland Olsen; Laila Busk
Gothjaelpsen; Carsten Sletten; Danuta Ciok

(74) Agent/Attorney
F B RICE and CO,605 Darling Street,BALMAIN NSW 2041

(56) Related Art
US 4095599
US 4681574

OPI DATE 30/12/98 APPLN. ID 74258/98
AOJP DATE 11/02/99 PCT NUMBER PCT/DK98/00212



AU9874258

INTL

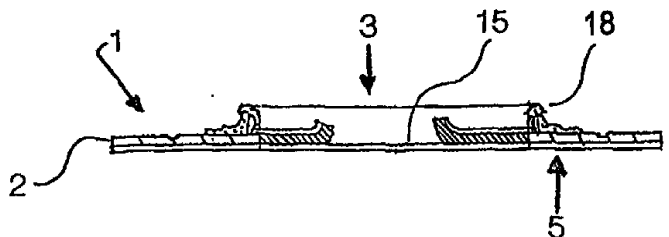
<p>(51) International Patent Classification ⁶ : A61F 5/445 // 5/443</p>	<p>A1</p>	<p>(11) International Publication Number: WO 98/53771 (43) International Publication Date: 3 December 1998 (03.12.98)</p>
<p>(21) International Application Number: PCT/DK98/00212 (22) International Filing Date: 25 May 1998 (25.05.98) (30) Priority Data: 0598/97 26 May 1997 (26.05.97) DK 1507/97 22 December 1997 (22.12.97) DK (71) Applicant (for all designated States except US): COLOPLAST A/S [DK/DK]; Høldedam 1, DK-3050 Humlebaek (DK). (72) Inventors; and (75) Inventors/Applicants (for US only): NIELSEN, Inger, Mann [DK/DK]; Vagtelvej 78, DK-2000 Frederiksberg (DK). OLSEN, Eskil, Høejland [DK/DK]; Hvidovrevej 51, DK-2930 Klampenborg (DK). GOTHJAELPSEN, Laila, Busk [DK/DK]; Engkaer 13, DK-2650 Hvidovre (DK). SLETTEN, Carsten [DK/DK]; Dronningens Tvaergade 27, 1.2, DK-1302 Koebenhavn K (DK). CIOK, Danuta [PL/DK]; Violens Kvarter 8, DK-2990 Nivaa (DK). (74) Common Representative: COLOPLAST A/S; Attn.: Kim Nilausen, Patent Dept., Høldedam 1, DK-3050 Humlebaek (DK).</p>		<p>(81) Designated States: AL, AM, AT, AT (Utility model), AU, AZ, BA, BB, BG, BR, BY, CA, CH, CN, CU, CZ, CZ (Utility model), DE, DE (Utility model), DK, DK (Utility model), EE, EE (Utility model), ES, FI, FI (Utility model), GB, GE, GH, GM, GW, HU, ID, IL, IS, JP, KE, KG, KP, KR, KZ, LC, LK, LR, LS, LT, LU, LV, MD, MG, MK, MN, MW, MX, NO, NZ, PL, PT, RO, RU, SD, SE, SG, SI, SK, SK (Utility model), SL, TJ, TM, TR, TT, UA, UG, US, UZ, VN, YU, ZW, ARIPO patent (GH, GM, KE, LS, MW, SD, SZ, UG, ZW), Eurasian patent (AM, AZ, BY, KG, KZ, MD, RU, TJ, TM), European patent (AT, BE, CH, CY, DE, DK, ES, FI, FR, GB, GR, IE, IT, LU, MC, NL, PT, SE), OAPI patent (BF, BJ, CF, CG, CI, CM, GA, GN, ML, MR, NE, SN, TD, TG).</p> <p>Published <i>With international search report. Before the expiration of the time limit for amending the claims and to be republished in the event of the receipt of amendments.</i></p>
<p>(54) Title: AN OSTOMY APPLIANCE</p> 		
<p>(57) Abstract</p> <p>The invention relates to an ostomy appliance comprising a body side member comprising an adhesive wafer or pad for securing the appliance to the user's skin, said wafer or pad having a hole for receiving a stoma, and an optionally separately exchangeable receiving member or bag secured to the body side ostomy member for receiving secretions from the ostomy, said ostomy appliance further comprising a sealing member disposed in the hole of the wafer or pad surrounding the stoma wherein the sealing member disposed in the hole of the wafer or pad surrounding the stoma, said sealing member having a hole for accommodating the stoma and said sealing member having balanced plastic and elastic properties allowing an adaptation of the hole of the ostomy appliance to a stoma by a temporary enlarging the hole by everting or rolling up the inner rim of the hole for accommodating the stoma. When the ostomy appliance of the invention has been placed over and around the stoma the adhesive sealing member may recover essentially to the original form to fit snugly to the stoma. Preferably at least the area of a release liner covering the separate sealing member is provided with a guide for adaptation of the hole of an ostomy appliance to the size of an ostomy, said guide being visible from the side of the release liner facing the sealing member.</p>		

TITLE

An Ostomy Appliance

FIELD OF THE INVENTION

The present invention relates to an ostomy appliance, an ostomy appliance body side member, an ostomy sealing member and to a method of applying an ostomy appliance body side member around a stoma.

BACKGROUND OF THE INVENTION

In connection with surgery for a number of diseases in the gastro-intestinal tract a consequence is, in many cases, that the colon, the ileum or the urethra has been exposed surgically and the patient is left with an abdominal stoma and the effluents or waste products of the body, which are conveyed through these organs, are discharged through the artificial orifice or opening and are collected in a collection bag, which is usually adhered to the skin by means of an adhesive wafer or plate having an inlet opening for accommodating the stoma. Also in connection with a fistula, the patient will have to rely on an appliance to collect the bodily material emerging from such opening.

Ostomy appliances are well known. Such appliances may be two-piece or one-piece appliances. In both types of appliances, a body side member is attached to the wearer's abdomen, and optionally a receiving member or bag is attached to the body side ostomy member for receiving exudates from the ostomy in case of a two-piece appliance.

When using one-piece appliances, the whole appliance, including the adhesive wafer or pad securing the appliance to the skin is removed and replaced by a fresh appliance. When using two-piece appliances, the body side ostomy member is let in place for several days, and only the receiving member or bag is replaced.

The service time of the body side ostomy member depends on the amount and aggressiveness of the exudates and of the tightness between the ostomy and the body side ostomy member.

In the known appliances it is necessary to change the body side member of a two-piece appliance when the centre part of the adhesive wafer or pad has been sufficiently deteriorated to allow access of the aggressive exudates to the skin surrounding the stoma, irrespective of the fact that the wafer as such has a much longer wearing time. The access of aggressive exudates to the skin is causing skin problems.

Skin problems are common for persons having a stoma. Generally, about 40 % have skin problems (Pearl et al. 1985 "Early local complications from intestinal stomas", Arch. Surg. 120; 1145-1147.) and the frequency is especially high for persons having an urostomy or ileostomy. About 80 % of the persons having an ileostomy have skin problems (Hellman, J.D., Lago, C.P. 1990 "Dermatologic complications in colostomy and ileostomy patients", International Journal of Dermatology, 29 (2); 129-133.). The skin problems are mostly pronounced in a circular area about the stoma (½ inch from the stoma) (Hellman and Lago 1990).

Frequent changing of the body side member of a two-piece appliance or the frequent exchange of a one-piece appliance is undesirable due to the irritation of the skin and the quality of life may be improved and the nuisance of the wearing of an ostomy appliance reduced if the intervals between exchanging of body side member can be increased.

It is known to place a ring on the skin before applying the body side member or to make a filling between the edge of the stoma and the shaped whole of the ostomy appliance in order to form a seal between the stoma and the ostomy appliance in order to alleviate the problems using a commercially available medical grade adhesive paste.

Such pastes are e.g. sold by Bristol-Myers Squibb under the trademark Stomahesive® or by Coloplast under the trade mark Coloplast® Paste.

These pastes, however, do not have a composition which has a sufficiently cohesion ensuring safe removal thereof without leaving residues on the skin and, on the other hand, the pastes often are so sticky that they cannot easily be shaped using the finger without sticking to the finger.

5 If using a paste, it should have a composition which is sufficiently tacky to secure the appliance or skin barrier to the abdomen, a cohesion ensuring safe removal thereof without leaving residues on the skin. On the other hand, the paste must not be so sticky that it cannot easily be shaped by a finger or hand without sticking to the hand. Furthermore, the paste must show a sufficient elasticity in order to be able to follow the
10 movements of the patient without slipping the skin and should also show a great resistance to erosion caused by aggressive exudates from an ostomy.

In GB Patent Application No. GB 2 290 974 is disclosed an ostomy appliance wherein a body-side is combined with a mouldable mass of non-hypoallergenic, non-memory putty-like adhesive, particularly based on hydrocolloid or hydrogel. Thus, GB Patent
15 Application No. GB 2 290 974 discloses a body-side ostomy member comprising a ring to which a bag-side coupling ring or a bag can be attached, said ring comprising a rib and a flange, said flange being mounted on a wafer of medical grade adhesive having a central whole of diameter at least 65 % of the internal diameter of the ring. A mould-
20 able mass of non-hypoallergenic, non-memory putty-like adhesive, particularly based on hydrocolloid or hydrogel, is disposed radially inward of the wafer so that it forms a protective mass surrounding the stoma. The mouldable mass has a thickness of 1.25 - 3 times that of the wafer and a central hole therein of a diameter no more than 1/10 th of the internal diameter of the ring. Both the medical grade adhesive and the mould-
able adhesive are adhered to the skin.

25 The mouldable mass of non-hypoallergenic, non-memory putty-like adhesive or flexible patch disclosed in GB Patent Application No. GB 2 290 974 is secured to the rim of the hole for receiving the stoma and may be displaced to engage with the stoma.

The ostomy appliances disclosed in GB Patent Application No. GB 2 290 974 suffers from the drawback that the mouldable sealing material is only foreseen to be changed together with the body side member of the appliance.

Furthermore, there is only disclosed that mouldable sealing material is to be disposed 5 or extruded towards the stoma which still leaves a considerable risk of an insufficient sealing as a sufficient amount of sealing material must be disposed to form a cohesive layer of adhesive sealing against the stoma. Thus, there is still a need for a sealing against a stoma ensuring that no leaks occur at the rim of the stoma and at the same time avoids the risk of thin spots or holes in the adhesive layer next to the stoma which 10 may give rise to lack of protection of the skin next to the stoma and lead to a shorter service time between exchange of the body side member.

It has surprisingly been found that it is possible to provide an ostomy appliance having a separate or integrated sealing member disposed in the hole of the wafer or pad surrounding the stoma offering a convenient and comfortable solution to the above prob- 15 lems and which at the same time enables a separation of the two functions, the sealing around an ostomy and the securing of a separately exchangeable receiving member or bag for receiving secretions from an ostomy to a body side ostomy member.

None of the above mentioned patents describes the use of a separate sealing member which may be exchanged or substituted separately.

20 This idea according to the invention differs from the above mentioned patents since the central ring (sealing member) in this case in some embodiments can be substituted without substituting the adhesive of a body side member which carries the bag and furthermore in that the adaptation of the ostomy appliance to the specific ostomy is rendered very simple and independent of the use of tools and in that the adaptation of the 25 appliance to the actual stoma is carried out by temporary enlarging the central hole thereof and not by inward displacement of adhesive mass to cover areas not covered hitherto to provide a snug engagement with the stoma.

BRIEF DESCRIPTION OF THE INVENTION

The invention relates in its broadest aspect to an ostomy appliance comprising a body side member, an optionally separately exchangeable receiving member or bag secured to the body side ostomy member and further a separate or integrated sealing member, 5 said appliance having a guide for adaptation of an ostomy appliance to the size of an ostomy.

Furthermore, the invention relates to a separate sealing member for placing in a hole of an ostomy appliance.

Still further, the invention relates to an ostomy appliance body side member having a 10 guide for adaptation of an ostomy appliance to the size of an ostomy as well as to different methods of applying an ostomy appliance body side member around a stoma by which the hole for receiving the stoma is adapted to the size of the stoma.

BRIEF DESCRIPTION OF THE DRAWINGS

The invention is disclosed more in detail with reference to the drawings in which

15 Fig. 1 shows a cross sectional view of an embodiment of an ostomy appliance of the invention,

Fig. 2 shows a release liner having an indication of the size of the hole of an ostomy appliance of the invention for accommodating an ostomy,

Fig. 3 shows a view from the distal side of the separate sealing member of an ostomy 20 appliance of the invention in which the separate sealing member has been partially everted to increase the size of the hole of an ostomy appliance of the invention for accommodating an ostomy and showing the indication of the size of the hole placed on the release liner below,

Fig. 4 shows a cross sectional view of the separate sealing member of Fig. 3,

25 Fig. 5 shows a cross sectional view of an embodiment of an ostomy appliance body side member according to the invention,

Fig. 6 shows a cross sectional view of a further embodiment of an ostomy appliance body side member according to the invention,

Fig. 7 shows a cross sectional view of the embodiment of Fig. 6 wherein the inner rim has been rolled up,

Fig. 8 shows a cross sectional view of yet a further embodiment of an ostomy appliance body side member according to the invention, and

5 Fig. 9 shows a cross sectional view of the embodiment of Fig. 8 wherein the inner rim has been compressed.

DETAILED DESCRIPTION OF THE DRAWINGS

Reference is made to Fig. 1 which shows an ostomy appliance according to the invention comprising a body side member 1 comprising an adhesive wafer or pad 2 for se-
10 curing the appliance to the user's skin, said adhesive being covered by a film 9
conventionally used, e.g. a LDPE film. Furthermore, the body side member is secured
by a sealing 10 to a flange 11, preferably made from a foam material. A receiving
member or bag 4 comprises a flange 12 secured to the flange 11 sealing by a layer of
an adhesive 13. The flange 12 may be welded to the receiving member either inside
15 the member or on the outside. The flange 11 preferably stretches beyond the inner rim
of the wafer or pad 2 in order to prevent that a mouldable adhesive mass 7 of a sepa-
rate sealing member adheres to the wafer or pad. Such adherence might prevent the
separate exchange of the sealing member independently of the exchange of the body
side member. The separate sealing member may comprise a sheet 16 for adhering to
20 the flange of body side member and for adhering the exchangeable receiving member
or bag. At the outer rim of the flange 11, the sheet 16 preferably stretches beyond the
rim of the flange to provide a handle 17 for gripping for separate exchange of the seal-
ing member. Such handle preferably stretches over the full periphery in order to avoid
adherence of the adhesive 13 of a separately exchangeable receiving member or bag
25 to the body side member. The handle may e.g. be a slit liner. The adhesive 13 may be
any adhesive being detachable from the two flanges in order to allow for an exchange
of only the receiving member or bag leaving the body side member and the separate
sealing member on the abdomen of the ostomate. It is desirable that the attachment
between the receiving member or bag and the separate sealing member is weaker
30 than the attachment between the separate sealing member and the body side mem-
ber. The adhesive 13 may be an acrylic adhesive or any conventional skin friendly

adhesive. Furthermore, the separate sealing member comprises a mouldable backing
14. The backing preferably has a tensile strength of 2-5 N/m² at an elongation of
300%.

The separate sealing member may be made from a mouldable adhesive in the form of
5 a paste of a skin-friendly adhesive being sufficiently tacky to secure the appliance or
skin barrier to the abdomen and a cohesion ensuring safe removal thereof without
leaving residues on the skin. The sealing member may be composed of one material
or may optionally be composed of two or more layers one of which being a mouldable
backing and may optionally be covered with a protecting layer or film.

10 All adhesive surfaces may be protected by release liners to be removed before
application.

The separate sealing member may be a uniform mouldable mass of a hypoallergenic,
substantially non-memory adhesive or it may comprise further constituents such as a
protecting film or a mouldable mesh.

15 The separate sealing member may be substituted together with the receiving member
4 leaving the body side member 1 on the skin. It is contemplated that the sealing mem-
ber may be substituted independently of the receiving member according to the need
of the user.

Now referring to Fig. 2 is shown a release liner having an indication of the size of the
20 hole of an ostomy appliance of the invention for accommodating an ostomy, at the side
in contact with the separate sealing member (distal as compared to the ostomy). In the
alternative, the indication may be placed on the side facing away from the separate
sealing member (proximal as compared to the ostomy) if the release liner is
transparent.

25 Fig. 3 shows a view from the distal side of the separate sealing member 5 of an os-
tomy appliance of the invention in which the separate sealing member has been

partially everted to increase the size of the hole of an ostomy appliance of the invention for accommodating an ostomy and showing the indication of the size of the hole placed on the release liner **15** below.

Fig. 4 shows a cross sectional view of the separate sealing member of Fig. 3 wherein the sealing member **5** in the form of a uniform adhesive mass **7** has been partially everted enlarging the hole **3** and revealing a larger part of the surface of the release liner **15** below and of the indication of the size of the hole.

The adhesive and the adhesive wafer may be composed of a hypo-allergenic, soft, easy-deformable, non-memory putty like adhesive material and is preferably a hydro-
10 colloid based adhesive or a hydrogel. A mouldable backing may e.g. be a Parafilm® or made from a polymer solution which is sprayed on the surface and protects the surface of the adhesive against dissolution by secretions from the stoma and prevent a tacky surface on the side facing the bag. The mouldable backing stretches out beyond the outer periphery of the ring in the form of a flange or adhesive layer. The mouldable
15 backing may have a tensile strength of from 1 to 10 N/mm², more preferred from 2 to 5 N/mm² and most preferred about 2.5 N/mm² at elongations up to 300%.

Fig. 5 shows a cross sectional view of an embodiment of an ostomy appliance body side member **1** according to the invention comprising an adhesive wafer or pad **2** for securing the appliance to the user's skin, said adhesive may be covered by a film conventionally used. Furthermore, the body side member comprises a separate sealing member **5** disposed in the hole of the wafer or pad surrounding the stoma and a release liner **15**. A receiving member or bag may be secured to a coupling ring **18**.

In the embodiment of Fig. 6 the sealing member is in the form of a uniform adhesive mass **7** which is thinner in the area next to the central hole for accommodating the
25 stoma. The sealing member is provided with a flange **8** and a release liner **15** and a mouldable backing **19**. In an alternative embodiment of the invention, the adhesive wafer or pad of a body side member and the sealing member are integrated into one unit having the desired balanced plastic and elastic properties allowing an adaptation of the

hole said adhesive unit being thinner in the area next to the central hole for accommodating the stoma.

In Fig. 7, the rim of the central hole has been partially rolled up forming a torus 20 and revealing a larger part of the surface of the release liner 15 below and of the indication 5 of the size of the hole.

In the embodiment of Fig. 8 the sealing member is in the form of a uniform adhesive mass 7 provided with grooves 21 encircling the central hole. The sealing member is provided with a flange 8 and a release liner 15. This embodiment may also comprise a mouldable backing covering the surface of the adhesive.

10

In Fig. 9 the rim of the central hole has been enlarged by partially compressing the grooves 21 revealing a larger part of the surface of the release liner 15 below and of the indication of the size of the hole.

The sealing member of the invention may have any desired form, e.g. similar to the 15 embodiments shown in WO98/17212.

DETAILED DESCRIPTION OF THE INVENTION

In a first aspect, the invention relates to an ostomy appliance comprising a body side member comprising an adhesive wafer or pad for securing the appliance to the user's skin, said wafer or pad having a hole for receiving a stoma, and an optionally separately exchangeable receiving member or bag secured to the body side ostomy member for receiving secretions from the ostomy said ostomy appliance further comprising a separate or integrated sealing member disposed in the hole of the wafer or pad surrounding the stoma, said sealing member having a hole for accommodating the stoma and said sealing member having balanced plastic and elastic properties allowing an 25 adaptation of the hole of the sealing member to a stoma by an at least temporary enlarging the hole by everting or rolling the inner rim of the hole for accommodating the stoma.

When the ostomy appliance of the invention has been placed over and around the stoma the adhesive sealing member may recover essentially to the original form to fit snugly to the stoma. The "release" may be performed using e.g. a finger or more or less automatically due to influence by elastic force, heat and/or humidity causing the 5 sealing member to essentially resume its original shape.

In a preferred embodiment of the invention at least the area of a release liner covering the separate sealing member is provided with a guide for adaptation of the hole of an ostomy appliance to the size of an ostomy, said guide being visible from the side of the release liner facing the sealing member. In one embodiment, the guide is placed at the 10 side of the release liner facing the sealing member. In another embodiment, the release liner is transparent and then the guide may be placed on either side.

An ostomy appliance according to this embodiment differs from known ostomy appliances comprising a guide for adaptation of the hole of an ostomy appliance to the size of an ostomy in that normally, the guide is placed on the side of the release liner facing 15 away from the sealing member and in that it is normally necessary to use scissors to cut according to the guide. Thus, according to the state of the art, it is necessary to use tools in order to adapt the size of the hole of an ostomy appliance to the size of an ostomy and, furthermore, the ostomy appliances of the state of the art do not offer a manner of secure sealing after adaptation by cutting. Both disadvantages of the appli- 20 ances of the state of the art are overcome by the invention rendering the indication visible from the distal side of the body side member and rendering the adaptation of an ostomy appliance to the specific ostomy very simple using only the finger and independent of the use of tools. Furthermore it differs in that the balanced modulus against deformation and elasticity of the adhesive of a sealing member of an ostomy appliance 25 of the invention is a result of the combined properties of a preferably substantially water-impervious backing layer or film and a skin friendly adhesive. Thus, in one extreme, the backing layer or film is elastic and the skin friendly adhesive is plastic, and in the opposite extreme, the backing layer or film is plastic, and the skin friendly adhesive is elastic. Any combination of properties therebetween fulfilling the requirements 30 will be suitable according to the invention.

In second aspect, the invention relates to an ostomy appliance body side member comprising an adhesive wafer or pad for securing the appliance to the user's skin, said wafer or pad having a hole for receiving a stoma, and a separate or integrated sealing member disposed in the hole of the wafer or pad surrounding the stoma wherein the 5 sealing member disposed in the hole of the wafer or pad surrounding the stoma shows balanced plastic and elastic properties allowing an adaptation of the hole of the ostomy appliance to a stoma by enlarging the hole for accommodating the stoma, and wherein at least the area covering the separate sealing member is provided with a guide for adaptation of the hole of an ostomy appliance to the size of an ostomy, said guide being 10 visible from the side of the release liner facing the sealing member. A body side member of the invention is preferably prepared so that a separately exchangeable receiving member or bag may be secured to the body side ostomy member for receiving secretions from the ostomy comprises a surface or coupling member for securing the separately exchangeable receiving member or bag.

15 In a third aspect, the invention relates to an ostomy sealing member in the form of a mouldable mass or ring which shows a sufficient adhesiveness to adhere to the skin and seal around an ostomy and between the ostomy and an ostomy appliance adapted to receive secretions from the ostomy, which sealing member shows a sufficient cohesion to be removed in one piece, independently of removal of the ostomy ap- 20 pliance without leaving remaining adhesive on the skin or the ostomy appliance, said sealing member having a hole for accommodating a stoma and said sealing member having balanced plastic and elastic properties allowing a temporary enlarging of the hole for receiving a stoma by everting or rolling the inner rim of the hole while placing the sealing member around the stoma.

25 In a fourth aspect, the invention relates to a method of applying an ostomy appliance body side member comprising an adhesive wafer or pad for securing the appliance to the user's skin, said wafer or pad having a hole comprising a sealing member having a hole for receiving a stoma wherein the hole of the sealing member is enlarged by everting the inner rim of the hole of the sealing member adapting of the hole to the size 30 of the ostomy, aligning the stoma and the hole of the ostomy appliance body for

accommodating the stoma and placing the body side member on the abdomen of the ostomate with the stoma projecting into the hole and bringing the sealing member to seal around the stoma, e.g. using a finger. The enlargement of the hole of the sealing member is preferably carried out by everting and rolling the inner ring forming a torus 5 which after release will unroll and seal against the stoma without risk formation of thin spots in the area around the stoma. The release may be effected manually using e.g. a finger or by influence of humidity causing a hydrocolloid-containing adhesive to swell. Using a hydrocolloid-containing adhesive will further contribute to establish a self-sealing effect around the stoma due to the swelling of the adhesive in use.

10 In the alternative, the sealing member may be provided with grooves encircling the central opening for an enlargement of the hole by lateral displacement outwardly of the rim compressing the grooves whereafter the sealing member will expand to provide a snug fit to the stoma.

Two different types of adhesives can be used for the sealing member - both being 15 adaptable to the stoma without the use of tools and having the property that they may be everted or rolled or compressed for a sufficient span of time to apply an ostomy appliance.

1. Mouldable adhesives which can be adapted to the stoma by displacement of the adhesive mass inwardly or outwardly whereby it forms a protective mass surrounding the 20 stoma.

2. Flexible adhesives which can be adapted to the stoma due to the flexibility and compliance whereby it forms a protective layer on the peristomal skin surrounding the stoma.

The mouldable adhesive used in the different compositions of the sealing member is 25 preferably characterised as being a hypoallergenic putty-like adhesive. The adhesive may preferably comprise some memory allowing for a displacement of adhesive to adapt an ostomy appliance to a stoma by enlarging the hole for accommodating the

stoma, whereafter the adhesive recovers essentially to the original form. The memory or elasticity must not, however, be so pronounced that a constriction of the stoma occurs.

The skin-friendly adhesive may be a skin-friendly adhesive known per se, e.g. an adhesive comprising hydrocolloids or other moisture absorbing constituents for prolonging the time of use. The adhesive may suitably be of the type disclosed in those disclosed in GB patent specification No. 1 280 631, in DK patent specifications Nos. 127,578, 148,408, 154,806, 147,226 and 154,747, in EP published application Nos. 0 097 846 and 0 415 183, in SE published application No. 365,410, in WO publication 10 No. 88/06894, in US patent specification No. 4,867,748, and in NO published application No. 157,686. Especially preferred are the adhesives disclosed in US patent Nos. 4,367,732 and 5,051,259 and DK patent specification No. 169,711.

A medical grade adhesive may be used for securing the sealing member to the peristomal skin. A variety of such barrier adhesives are known in the art and may be used 15 here, one such formulation being disclosed, for example in patent DK 147035 and US 4551490. The mouldable adhesive may be composed of a hypoallergenic, soft, easy-deformable, non-memory putty like adhesive material and is preferably a hydrocolloid based adhesive or a hydrogel. The mouldable backing, e.g. Parafilm® or a polymer solution which is sprayed on the surface, protects the surface of the mouldable mass 20 against dissolution by secrete from the stoma and prevent a tacky surface on the side facing the bag.

The backing layer or film may be of any suitable material known per se for use in the preparation of ostomy appliances or wound dressings e.g. a foam, a non-woven layer or a film of polyurethane, polyethylene, polyester or polyamide or optionally a copoly- 25 mer thereof. In accordance with the invention it has surprisingly been found that the use of a thinner backing layer or film than is normally used when preparing ostomy appliances, an improved adaptability is obtained at the same time as the modulus is reduced. The modulus may be from 1 to 10 N/mm², preferably from 2 to 5 N/mm². These properties may be obtained using the same load of adhesive as is conventionally used,

and thus, the conventional properties of the adhesive are retained as opposed to the case in which the load of adhesive was lowered generally giving a risk of insufficient tack and adhesive properties. The layer of adhesive may preferably be thinner along the inner rim of the adhesive sealing member to improve the mouldability.

5 Using a layer or film having a low modulus allowing an easy deformation during application but yet a sufficiently high elasticity to essentially prevent deformation after application ensures that the adhesive does not constrict the stoma when recovering to establish a snug sealing against the stoma.

The medical grade adhesive secures the unit to the peristomal skin. The flexible back-
10 ing, protects the surface of the adhesive against dissolution by secretions from the stoma and prevent a tacky surface on the side facing the bag.

This embodiment offers the following advantages: it is simple/easy to handle, it may be adapted to stoma without use of tools, it gives rise to no or very little residues on skin after removal, it gives rise to no or little erosion of adhesive, it may easily be adapted
15 to complicated shapes of the stoma and it reduces the risk of an insufficient sealing when disposing or extruding mouldable sealing material towards the stoma.

The adhesive is preferably a pressure sensitive adhesive having a high degree of plasticity. The ratio between plastic (viscous) modulus and elastic modulus is often referred to as the tangens delta value. A tangens delta value between 0.5 and 1.2, preferably
20 between 0.8 and 1.0 has been shown to be suitable combined with a elastic modulus (G') of at least 10^2 Pa, preferably of at least 10^4 Pa. The tangens delta value of conventional PSAs is normally from 0.4 to 0.8.

Adhesives of a non-memory type may e.g. be a homogeneous mixture of a pressure sensitive adhesive component, mineral oil, and hydrocolloid gums or cohesive
25 strengthening agents as the mass disclosed in US patent No. 4,204,540. The mass may also be a composition including one or more hydrocolloids, a film former which is butyl ester of polycarboxylic resin formed from vinyl methyl ether and maleic

anhydride, a plasticizer, a thickening agent and an alcohol solvent as disclosed in EP patent No. 0 048 556. A further paste is disclosed in US patent No. 5,369,130. This composition comprises a liquid rubber component and a filler component. The rubber component is a diene-type liquid rubber, preferably butadiene- or isoprene-type. The
5 filler component is selected from the groups consisting of inorganic fillers, natural polymers, semisynthetic water-soluble polymers and synthetic water-soluble polymers. A further composition of a skin protective gel containing polyvinyl methylether or monoisopropyl ester of polyvinylmethylether maleic acid is disclosed in US patent No. 3,876,771. The composition is a made up of a film forming protective colloidal material
10 in combination with a solvent and a gelling agent. Isopropanol is the solvent, monoisopropyl ester of polyvinyl methylether/maleic acid is a film former and polyvinylpyrrolidone, polyvinyl methylether, polyacrylic acid and hydroxypropyl cellulose are the gelling agents. A hydrophilic elastomeric pressure sensitive material is disclosed in US patent No. 4,750,482. This composition is a water-insoluble, hydrophilic, pressure-
15 sensitive adhesive including at least one irradiation cross-linked synthetic organic polymer (predominantly of derived from vinylpyrrolidone) and an adhesive plasticizer (polyethylene glycol).

The composition disclosed in EP 0 048 556 B1 suffers from the drawback that it comprises a considerable amount (25% to 45% by weight) of alcohol, ethanol and isopropanol being preferred. When using such a paste, there it is to be observed that only a
20 limited time for forming the paste after the application as the paste cures when exposed to air. Furthermore, the amount of alcohol trapped in the paste must be minimised in order to avoid less attractive physical properties due to an adverse effect on the properties of the adhesive of an ostomy appliance which is placed upon the paste.
25 Still further, the considerable amount of alcohol may irritate the skin and such a composition is not advisable to use on skin which has been sensibilised.

The pastes disclosed in US patent No. 4,204,540 suffers from the drawback that the shapeability is very dependant of the content of mineral oil. If an insufficient amount of mineral oil is added the composition will be too tough to shape and if too much mineral
30 oil is added the composition becomes sticky and difficult to handle. Generally, pastes consisting of polyisobutylene, butyl rubber and mineral oil may be very hard, if the

content of butyl rubber is high and hence, the paste will be difficult to shape, or it will be very soft and liquid if the content of butyl rubber is low and the content of mineral oil is high.

A preferred adhesive composition to be used in the ostomy appliances of the invention 5 are adhesive compositions comprising a water-dispersible polyester showing a very rapid water absorption and improving the wet tack and, at the same time, resistance to disintegration upon contact with body fluids.

A preferred non-memory putty-like mass to be used according to the invention is in the form of a mouldable mass of a hypo-allergenic, substantially non-memory putty-like ad-
10 hesive comprising

- a) a blockcopolymer having a major content of di-block copolymer,
- b) a tackifying liquid constituent, and
- c) a waxy constituent.

In a preferred embodiment the sealing member has a flange stretching from the outer
15 rim thereof. Such a flange preferably has adhesive on the surface and provides an extra security against leaks and excludes direct contact between the exudates and the coupling part of the ostomy device. Thus, a pollution or contamination of parts of the body side member during service or exchange of receiving member or bag is avoided. Avoidance of pollution or contamination of the body side member is of great impor-
20 tance when extending the wear time of the body side member as remains of the exudate on the body side member which may cause odour are avoided.

Additionally, this embodiment renders it possible to separate the two functions of the sealing around an ostomy and the securing of a separately exchangeable receiving member or bag for receiving secretions from an ostomy to a body side ostomy mem-
25 ber in that it is not mandatory that the securing of the separately exchangeable receiving member to the body side ostomy member impervious to liquid.

The separately exchangeable receiving member or bag may be secured to the body side ostomy member using an adhesive adhering to a flange or by mechanical means.

Mechanical fastening means for securing the separately exchangeable receiving member or bag releasably to the body side ostomy member may e.g. a traditional coupling system using a coupling ring or a zip-like fastener, snaps, buckles, buttons or rings.

A zip-like fastener may e.g. be of the type known for closing plastic bags, e.g. marketed under the trademark Minigrip®.

A fastening means may also be placed between the separate sealing member disposed in the hole of the wafer or pad surrounding the stoma and the body side member.

In a preferred embodiment of the invention, the attachment is placed between the sealing member disposed in the hole of the wafer or pad surrounding the stoma and the body side member is obtained using an adhesive.

This embodiment renders it simple to discriminate between the securing of the separately exchangeable receiving member or bag for receiving secretions from an ostomy and of the separate sealing member disposed in the hole of the wafer or pad surrounding the stoma. Thus, it is simple to decide whether to exchange only the receiving member or bag or to exchange the receiving member or bag and the separate sealing member disposed in the hole of the wafer or pad surrounding the stoma.

20 MATERIALS AND METHODS

Kraton® G1726 from Shell: Styrene-ethylenebutylene-styrene copolymer (SEBS) having a molecular weight of 45,000 as determined by GPC and a content of diblock copolymer of 70%.

Kraton® D1118 from Shell: Styrene-butadiene-styrene copolymer (SBS) having a molecular weight of 103,000 (GPC) and a content of diblock copolymer of 80%.

Vector® 4114 from Exxon: Styrene-isoprene-styrene copolymer (SIS) having a molecular weight of 130,000 and a content of diblock copolymer of 40% and 15% styrene.

Vistanex® LM-MH from Exxon: polyisobutylene (PIB) having a molecular weight of 90,000 (GPC).

AQ1045 from Eastman. A branched water-dispersible polyester having a Brookfield viscosity at 177 °C of 3,000 - 6,000 cP.

5 AQ1350 from Eastman. A branched water-dispersible polyester having a Brookfield viscosity at 177 °C of 28,000 - 45,000 cP.

Kraton® D 1107 from Shell Chemical Company. Styrene-isoprene-styrene copolymer (SIS) having a molecular weight of 212,000-260,000 as determined by GPC and 15% styrene.

10 LVS1 101 from Shell Chemical Company. Styrene-isoprene diblock copolymer (SI) having a molecular weight of about 30,000 as determined by GPC and 13% styrene.

Wax Total 40/60 from TOTAL

Petroleum jelly: Vaseline Album from Witco

Diocyladipate from International Speciality Chemicals Ltd. A plastisizer.

15 METALYN 200, a methyl ester of rosin from Hercules

Eastoflex E1003, E 1060 and E 1200 from Eastman. propylene-ethylene copolymers.

Eastoflex D127 from Eastman. A propylene/1-hexene copolymer

Vestoplast 704, 708 and 750: amorphous propylene-rich poly- α -olefins from Hüls Chemie

20 Wingtack 10 from Goodyear. A liquid polyterpene tackifier resin

Arkon P-90 from Arakawa Forest Chemical Industries Ltd. A hydrogenated cyclopentadiene resin.

Polybutene oil: Hyvis® 10 from BP having a molecular weight of 1,500.

Polybutene: Hyvis® 2000 from BP having a molecular weight M_w of 30,000

Mineral Oil: PL 500 from Parafliuid Mineral Oel

Tackifier resin: Regalite® R91 resin from Hercules or Arkon® P-90 resin from Arakawa

Glycerol.

5 PEG 400 from Hoechst. Polyethylene glycol.

Sodium carboxymethylcellulose: Akucell® AF2881 from Akzo or
Blanose® 9H4XF from Hercules Corp.

Guar gum: Guar Gum FG 200 from Nordisk Gelatine

Pectin: Pektin LM 12CG Z from Copenhagen Pectin or
10 Pektin USP/100 from Copenhagen Pectin

Klucel HXF EP. Hydroxypropyl cellulose.

Gelatin: Gelatine P.S. 98.240.233 from ED. Geistlich Sohne AG

Zinc Oxide: Zinkoxid Pharma from Hoechst AG

A Z mixer Type LKB 025 from Herman-Linden was used.

EXPERIMENTAL PART**EXAMPLE 1.**

Preparation of a mouldable mass to be used according to the invention.

100 grams of Kraton® G1726 was used and the amounts of other ingredients used
5 correspond to the composition stated in Table 1.

Equal amounts of Kraton® G1726 (SEBS) and of Vistanex® LM-MH were mixed in a Z Mixer for 20 minutes at 160 °C under a vacuum of 100 mbar. Then, the vacuum was released, the mixing was continued at 160 °C for 10 minutes and the remains of Vistanex® LM-MH, the wax, and petroleum jelly were admixed and mixed for 10 minutes
10 each. Then, the heating was turned off, and guar gum was added at maximum 90 °C under a vacuum of 100 mbar and mixed for 10 minutes. Finally, pectin, gelatine and zinc oxide were admixed at a temperature of 90 °C and mixed for 10 minutes.

EXAMPLE 2.

Preparation of a mouldable mass to be used according to the invention.

15 100 grams of Kraton® G1726 was used and the amounts of other ingredients used correspond to the composition stated in Table 1.

Equal amounts of Kraton® G1726 (SEBS) and Vistanex® LM-MH were mixed in a Z Mixer for 20 minutes at 160 °C under a vacuum of 100 mbar. Then, the vacuum was released, the mixing was continued at 160 °C for 10 minutes and the remains of Vistanex® LM-MH, the wax, and Hyvis® 10 or PL 500 were admixed and mixed for 10
20 minutes each. Then, the heating was turned off, and guar gum was added at maximum 90 °C under a vacuum of 100 mbar and mixed for 10 minutes. Finally, pectin, gelatine and zinc oxide were admixed at a temperature of 90 °C and mixed for 10 minutes.

EXAMPLES 3 - 5

Preparation of mouldable masses to be used according to the invention.

In the same manner as described in Example 2 above, mouldable masses according to the invention were produced having the compositions stated in the below Table 1:

5 **Table 1**

Composition of mouldable masses of the invention of Examples 1 - 5 stated in % by weight

Component	Example 1	Example 2	Example 3	Example 4	Example 5
SEBS	5	5	5	10	8
PIB	30	15	15	10	18
Microcrystalline wax	5	5	5	5	5
Petroleum jelly	10				
Polybutene oil		25			
Liquid paraffin			25	25	20
CMC			12	20	15
Guar Gum	15	20			
Pectin	15	10	10	10	8
Gelatine	18	17.5	27	20	25
Zinc white	2	2.5	1		3

EXAMPLE 6.

Preparation of a mouldable mass to be used according to the invention.

10 Equal amounts of Kraton® G1726 (SEBS) and Hyvis® 2000 were mixed in a Z Mixer for 30 minutes at 160 °C under a vacuum of 100 mbar and the Hyvis® 2000 was added in four parts to ensure homogeneity during the admixing over a period of 20 minutes. Then, the remains of Hyvis® 2000 was added in four parts at 160 °C over 30 minutes and the vacuum was released. The Hyvis® 10 was added in four parts and 15 mixed for 15 minutes. Wax was added and mixed for 10 minutes. Then, the heating was turned off, and guar gum and CMC were added at maximum 90 °C under a

vacuum of 100 mbar and mixed for 10 minutes. Finally, pectin, gelatine and zinc oxide were admixed at a temperature of 90 °C and mixed for 10 minutes.

EXAMPLES 7 - 8

Preparation of mouldable masses to be used according to the invention.

In the same manner as described in the Example 2 above, mouldable masses according to the invention were produced having the compositions stated in the below Table 2:

Table 2

Composition of mouldable masses of the invention of Examples 6 - 8 stated in % by weight.

Component	Example 6	Example 7	Example 8
SEBS (Diblock content about 70%)	5		
SIS (Diblock content about 40%)		5	
SB (Diblock content about 80%)			5
PIB		15	15
Polybutene (M_w 30.000)	15		
Polybutene oil	25	25	25
Microcrystalline wax	5	5	5
CMC	10	13	25
Guar Gum	15		
Pectin	5	10	8
Gelatine	18	22	15
Zinc white	2	5	2

EXAMPLES 9 - 10

Preparation of mouldable masses to be used according to the invention.

Equal amounts of Kraton® G1726 (SEBS) and Hyvis® 2000 were mixed in a Z Mixer for 30 minutes at 160 °C under a vacuum of 100 mbar and the Hyvis® 2000 was added in four parts to ensure homogeneity during the admixing over a period of 20

minutes. Then, the remains of Hyvis® 2000 was added in four parts at 160 °C over 30 minutes and the vacuum was released. The Hyvis® 10 was added in four parts and mixed for 15 minutes. Resin and wax was added and mixed for 10 minutes each. Then, the heating was turned off, and CMC were added at maximum 90 °C under a vacuum of 100 mbar and mixed for 10 minutes. Finally, pectin, gelatine and zinc oxide were admixed at a temperature of 90 °C and mixed for 10 minutes.

Table 3

Composition of mouldable masses of the invention of Examples 9 - 10 stated in % by weight:

Component	Example 9	Example 10
SEBS (Diblock content about 70%)	5	5
Polybutene (M _w 30.000)	10	5
Polybutene oil	25	25
Resin	5	10
Microcrystalline wax	5	5
CMC	15	15
Pectin	10	10
Gelatine	24	24
Zinc white	1	1

10 The pastes produced in the above Examples are ready to use but may preferably be packed in metered amounts, e.g. in a blister pack or rod for shipment. A rod may be rolled and have a release liner on one or both sides. The product is preferably produced and packed under aseptic conditions.

Preparation of preferred adhesives to be used according to the invention is disclosed
15 in the below Examples

Example 11

An adhesive agent having the composition stated in Table 4 was prepared in a Z-blade mixer. Before the mixing, the mixing chamber was heated to 140°C by means of an oil heater. AQ1045, Eastoflex D127, Eastoflex E1003, dioctyladipate and the

hydrocolloids were weighed out separately. Firstly Eastoflex D127 and E1003 were mixed for 15 minutes. AQ1045 was added and the mixing continued for 10 minutes. Dioctyladipate was added and mixed for additional 10 minutes. The heat supply was turned off and the mixing chamber was cooled to 80°C. The hydrocolloids (a mixture of 5 pectin, hydroxypropyl cellulose and gelatine in the ratio 1:1.5:1) were added and the mixing was continued in vacuum until a total mixing time of 60 minutes. The adhesive agent was removed from the mixer and pressed into 1 mm thin plates between two sheets of silicon paper in a hydraulic press at 90°C.

Example 12

10 An adhesive agent having the composition stated in Table 4 was prepared in a Z-blade mixer. Before the mixing, the mixing chamber was heated to 140°C by means of an oil heater. AQ1350, Eastoflex D127, Eastoflex E1003, Wingtack 10 and dioctyladipate were weighed out separately. Firstly Eastoflex D127 and E1003 were mixed for 15 minutes. AQ1350 and was added and the mixing continued for 10 minutes. Wingtack
15 10 was added and mixed for additional 10 minutes and finally dioctyladipate was added. The adhesive agent was removed from the mixer and pressed into 1 mm thin plates between two sheets of silicon paper in a hydraulic press at 90°C.

Example 13

An adhesive agent having the composition stated in Table 4 was prepared in a Z-blade
20 mixer. Before the mixing, the mixing chamber was heated to 150°C by means of an oil heater. AQ1045, Vector 4114, LVSI101, dioctyladipate and the hydrocolloids were weighed out separately. Firstly Vector and dioctyladiadipate were mixed at 150°C for 15 minutes. LVSI 101 was added and the mixing continued for 10 minutes. The mixing chamber was cooled to 130°C and AQ1045 was added and the mixing was continued
25 for an additional 15 minutes. The heat supply was turned off and the mixing chamber was cooled to 80°C. The hydrocolloids, a mixture of pectin and hydroxypropylcellulose in the ratio 1:1, and finally zinc oxide were added and the mixing was continued in vacuo until a total mixing time of 60 minutes. The adhesive agent was removed from

the mixer and pressed into 1 mm thin plates between two sheets of silicon paper in a hydraulic press at 90°C.

Example 14

An adhesive agent having the composition stated in Table 4 prepared in a Z-blade
5 mixer. Before the mixing, the mixing chamber was heated to 130°C by means of an oil
heater. AQ1045 and glycerol and the hydrocolloids were weighed out separately.
Firstly AQ1045 and glycerol were mixed at 130°C for 15 minutes. The heat supply was
turned off and the mixing chamber was cooled to 80°C. The hydrocolloids, a mixture of
pectin and gelatine in the ratio 1:2, were added and the mixing continued in vacuum
10 until a total mixing time of 40 minutes. The adhesive agent was removed from the
mixer and is pressed into 1 mm thin plates between two sheets of silicon paper in a hy-
draulic press at 90°C.

Example 15

An adhesive agent having the composition stated in Table 4 was prepared in a Z-blade
15 mixer. Before the mixing, the mixing chamber was heated to 130°C by means of an oil
heater. AQ1045 and PEG 400 and the hydrocolloids were weighed out separately.
Firstly AQ1045 and PEG 400 were mixed at 130°C for 15 minutes. The heat supply
was turned off and the mixing chamber was cooled to 80°C. The hydrocolloids, a mix-
ture of hydroxypropylcellulose and gelatine in the ratio 1:1, were added and the mixing
20 continued in vacuo until a total mixing time of 40 minutes. The adhesive agent was re-
moved from the mixer and pressed into 1 mm thin plates between two sheets of silicon
paper in a hydraulic press at 90°C.

Example 16

An adhesive agent having the composition stated in Table 4 was prepared in a Z-blade
25 mixer. Before the mixing, the mixing chamber was heated to 150°C by means of an oil
heater. AQ1045, Vector 4114, LVSI 101, Arkon P-90 and the hydrocolloids were
weighed out separately. Firstly Vector was mixed at 150°C for 15 minutes. LVSI 101
was added and the mixing continued for 15 minutes. The mixing chamber was cooled
to 130°C and Arkon P-90 followed by AQ1045 were added and the mixing was

continued for an additional 30 minutes. The heat supply was turned off and the mixing chamber was cooled to 80°C. The pectin was added and the mixing was continued in vacuo until a total mixing time of 90 minutes. The adhesive agent was removed from the mixer and pressed into 1 mm thin plates between two sheets of silicon paper in a 5 hydraulic press at 90°C.

Table 4

Constituent	Example 11	Example 12	Example 13	Example 14	Example 15	Example 16
AQ1045	35		30	50	40	30
AQ 1350		50				
LVSI 101			29			25
Vector 4114			5			5
Doctyladipate	5	5	5			
Eastoflex D127	15	15				
Eastoflex E1003	10	15				
Wingtack 10		15				
Arkon P-90						10
Glycerol				20		
PEG 400					20	
Bianose 9H4XF						
Pectin USP/100	10		15	10		30
Klucel HXF EP	15		15		20	
Gelatine	10			20	20	
Zinc oxide			1			

EXAMPLES 17 - 21

Adhesives being suitable as pastes having the compositions stated in Table 5 were prepared in a Z-mixer in the same manner as described in Example 11

Table 5

Constituent	Example 17	Example 18	Example 19	Example 20	Example 21
Eastoflex E 1003	15	15	15	20	20
Eastoflex E 1060				2.5	2.5
AQ 1350	35	35	35	35	35
Diocyladipate	5	5	5	5	
Metalyn 200					5
Vestoplast 708	10	5	5	2.5	2.5
Vestoplast 704		5	2.5		
Vestoplast 750	10		2.5		
Gelatine	10	10	10	10	10
Pectin	15	10	10	10	10
Klucel		15	15	15	15

THE CLAIMS DEFINING THE INVENTION ARE AS FOLLOWS:-

1. An ostomy appliance comprising a body side member comprising an adhesive wafer or pad for securing the appliance to the user's skin, said wafer or pad having a hole for receiving a stoma, and an optionally separately exchangeable receiving member or bag secured to the body side ostomy member for receiving secretions from the ostomy, characterised in that the ostomy appliance further comprises a sealing member disposed in the hole of the wafer or pad surrounding the stoma, said sealing member having a hole for accommodating the stoma and said sealing member having balanced plastic and elastic properties allowing an adaptation of the hole to a stoma by temporary enlarging the hole by everting or rolling the inner rim of the hole for accommodating the stoma.
2. An ostomy appliance as claimed in claim 1, characterised in that at least the area of a release liner covering the separate sealing member is provided with a guide for adaptation of the hole of an ostomy appliance to the size of an ostomy, said guide being visible from the side of the release liner facing the sealing member.
3. An ostomy appliance as claimed in claim 1 or 2, characterised in that the sealing member is in the form of a mouldable mass or ring of a hypo-allergenic, adhesive having a backing layer or film.
4. An ostomy appliance as claimed in any one of claims 1-3, characterised in that the sealing member has a flange stretching from the outer rim thereof.
5. An ostomy appliance as claimed in any one of claims 1-4, characterised in that a separately exchangeable receiving member or bag is secured releasably to the body side ostomy member by an adhesive or by mechanical fastening means.
6. An ostomy appliance as claimed in claim 5, characterised in that the mechanical fastening means is a traditional coupling system using a coupling ring or a zip-like fastener, snaps, buckles, buttons, rings.
7. An ostomy appliance body side member comprising an adhesive wafer or pad for securing the appliance to the user's skin, said wafer or pad having a hole for receiving a stoma, and an optionally exchangeable sealing member disposed in the hole of the wafer or pad surrounding the stoma wherein the sealing member disposed in the hole of the wafer or pad surrounding the stoma shows balanced plastic and elastic properties allowing an adaptation



of the hole of the ostomy appliance to a stoma by temporarily enlarging the hole by everting or rolling the inner rim of the hole for accommodating the stoma.

8. An ostomy appliance body side member as claimed in claim 7, characterised in that it comprises a surface or coupling member for securing a
5 separately exchangeable receiving member or bag may be secured to the body side ostomy member for receiving secretions from the ostomy.

9. An ostomy sealing member in the form of mouldable mass or ring which shows a sufficient adhesiveness to secure the sealing member to the skin and seal around an ostomy and between the ostomy and an ostomy appliance
10 adapted to receive secretions from the ostomy, which sealing member shows a sufficient cohesion to be removed in one piece, independently of removal of the ostomy appliance without leaving remaining adhesive on the skin or the ostomy appliance, said sealing member having a hole for accommodating a stoma and said sealing member having balanced plastic and elastic properties allowing a
15 temporary enlarging of the hole for receiving a stoma by everting or rolling the inner rim of the hole while placing the sealing member around the stoma.

10. A method of applying an ostomy appliance body side member comprising an adhesive wafer or pad for securing the appliance to the user's skin, said wafer or pad having a hole comprising a sealing member having a hole for receiving a
20 stoma wherein the hole of the sealing member is enlarged by everting or rolling the inner rim of the hole of the sealing member adapting of the hole to the size of the ostomy, aligning the stoma and the hole of the ostomy appliance body for accommodating the stoma and placing the body side member on the abdomen of the ostomate with the stoma projecting into the hole and brining the sealing
25 member to seal around the stoma.

11. An ostomy appliance substantially as described with reference to the accompanying drawings.

Dated this seventh day of September 2000

Coloplast A/S

Patent Attorneys for the Applicant:

F B RICE & CO



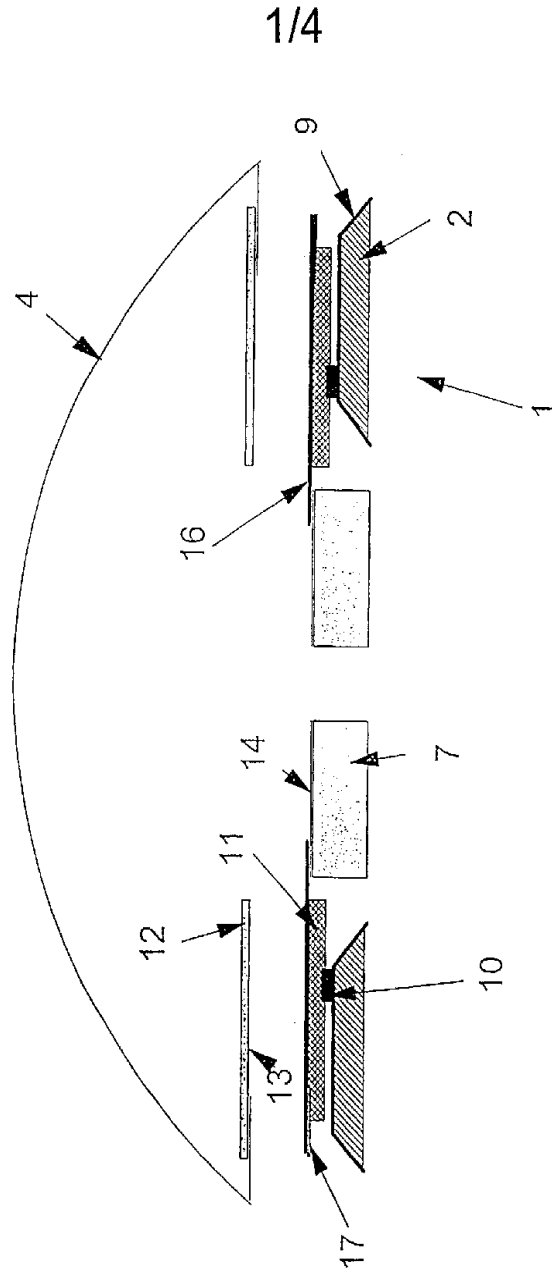

Fig. 1

2/4

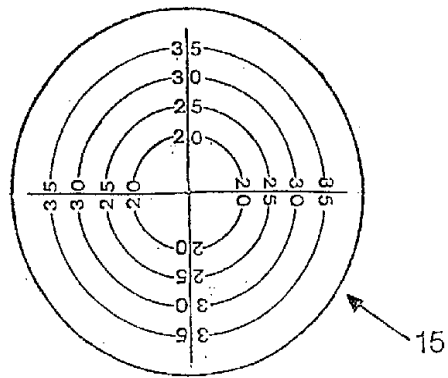

Fig. 2

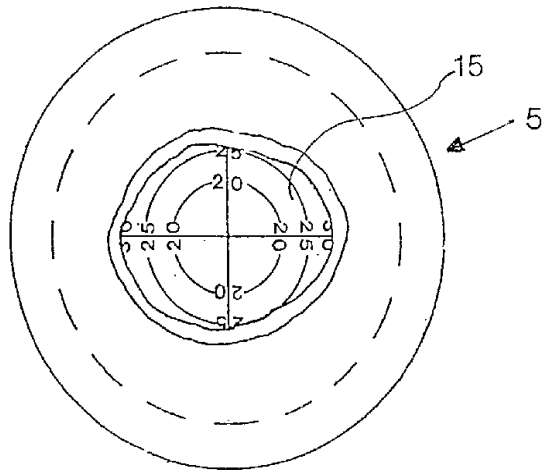

Fig. 3

3/4

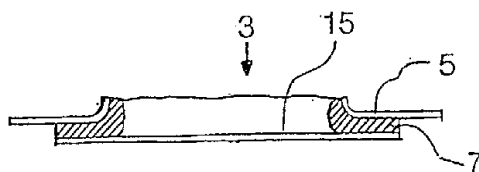

Fig. 4

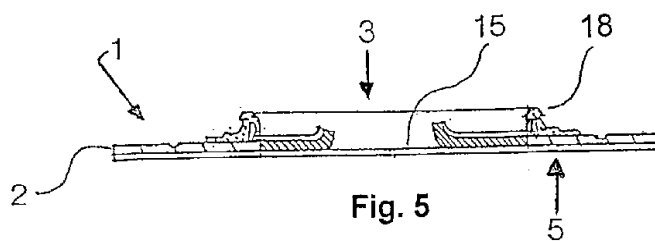

Fig. 5

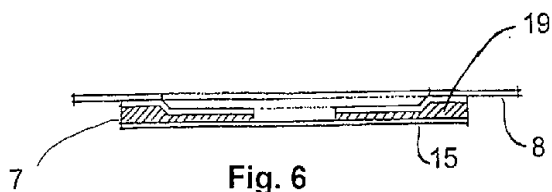

Fig. 6

4/4

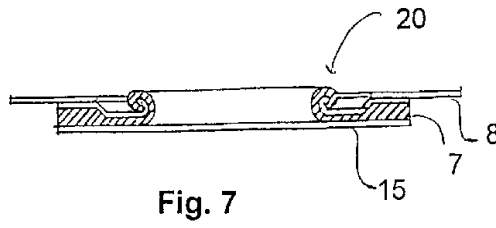

Fig. 7

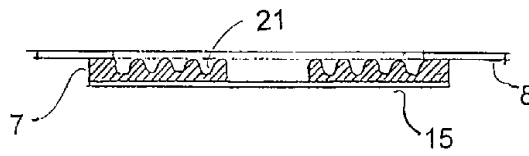

Fig. 8

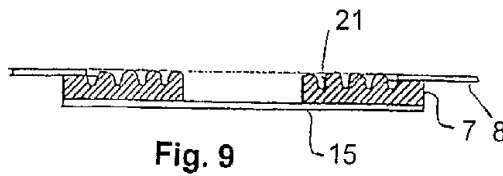

Fig. 9