



US006988892B2

(12) **United States Patent**
Dragan et al.

(10) **Patent No.:** **US 6,988,892 B2**
(45) **Date of Patent:** **Jan. 24, 2006**

(54) **DENTAL MATERIAL CONTAINER WITH POROUS FLOW THROUGH APPLICATOR**

(75) Inventors: **William B. Dragan**, Easton, CT (US);
John J. Discsko, Trumbull, CT (US)

(73) Assignee: **Centrix, Inc.**, Shelton, CT (US)

(*) Notice: Subject to any disclaimer, the term of this patent is extended or adjusted under 35 U.S.C. 154(b) by 84 days.

4,941,873 A	7/1990	Fischer	
4,997,371 A	3/1991	Fischer	
5,122,056 A *	6/1992	Barbee	433/80
5,152,742 A	10/1992	Simpson	
5,454,660 A *	10/1995	Sakurai et al.	401/266
5,816,804 A	10/1998	Fischer	
5,829,976 A	11/1998	Green	
6,059,570 A	5/2000	Dragan et al.	
6,099,307 A	8/2000	Discsko, Jr.	
6,202,897 B1 *	3/2001	Martin et al.	222/386
6,283,933 B1	9/2001	D'Alessio et al.	
6,382,972 B1 *	5/2002	Fischer et al.	433/90

(21) Appl. No.: **10/425,017**

(22) Filed: **Apr. 28, 2003**

(65) **Prior Publication Data**

US 2003/0198918 A1 Oct. 23, 2003

Related U.S. Application Data

(63) Continuation of application No. 09/906,369, filed on Jul. 16, 2001, now Pat. No. 6,585,511.

(51) **Int. Cl.**
A61C 5/04 (2006.01)

(52) **U.S. Cl.** **433/90**

(58) **Field of Classification Search** 433/89,
433/90; 401/176, 177, 207, 261, 196; 604/1,
604/2, 3; 132/320

See application file for complete search history.

(56) **References Cited**

U.S. PATENT DOCUMENTS

3,481,676 A	12/1969	Schwartzman
3,519,364 A	7/1970	Truhan
4,218,155 A	8/1980	Weidner
4,432,749 A	2/1984	Snyder et al.
4,875,602 A	10/1989	Chickering et al.
4,925,327 A	5/1990	Wirt

FOREIGN PATENT DOCUMENTS

WO WO 98/11852 3/1998

* cited by examiner

Primary Examiner—Todd E. Manahan
(74) *Attorney, Agent, or Firm*—Fattibene & Fattibene; Paul A. Fattibene; Arthur T. Fattibene

(57) **ABSTRACT**

A dental nozzle, cartridge, capsule or container having a porous or foam flow through applicator connected at the discharge end thereof; and having a body portion containing or receiving a low viscosity dental material. In one form, a displaceable plunger or piston is disposed within the body portion to extrude the dental material through the discharge orifice and attached flow through applicator. The foam or porous applicator may be connected to the discharge end at the time of manufacture as by molding, or by mechanically connecting or by adhering the same to the discharge orifice as part of the assembly process. The flow through applicator may be made in a variety of shapes to provide improved and controlled application of a low viscosity dental material to a dental site. Additionally, the porosity of the porous or foam material may be matched to the viscosity of the dental material to control the flow of dental material therethrough.

5 Claims, 4 Drawing Sheets

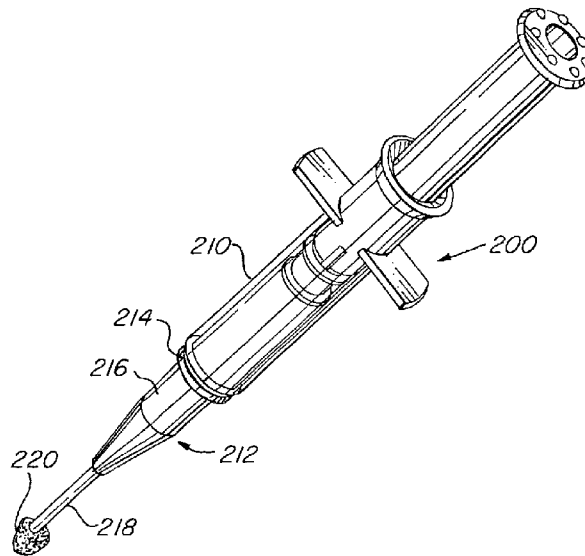

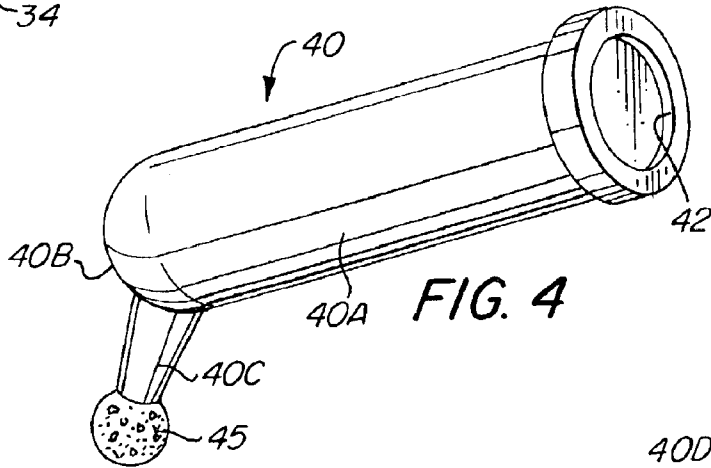
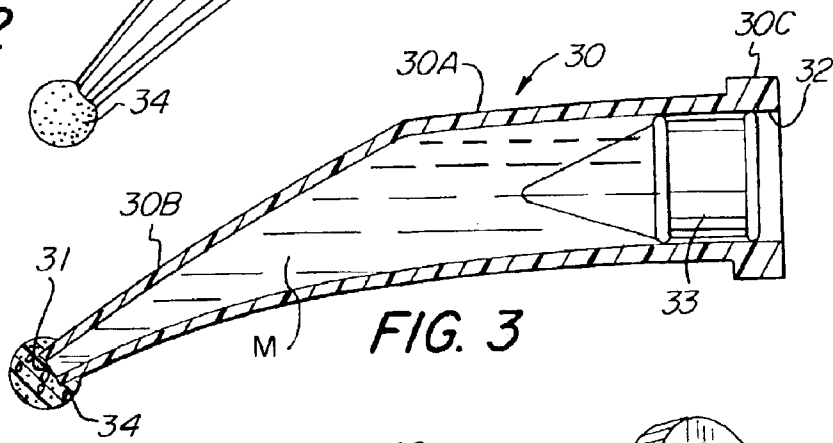
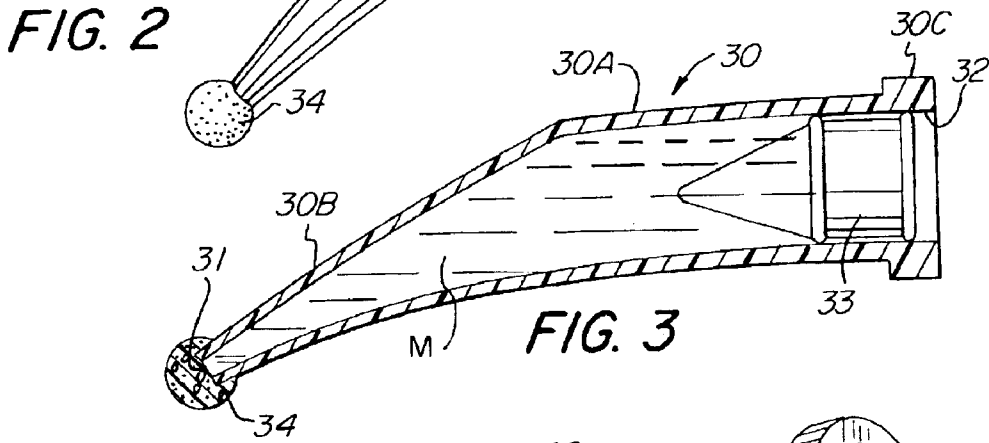
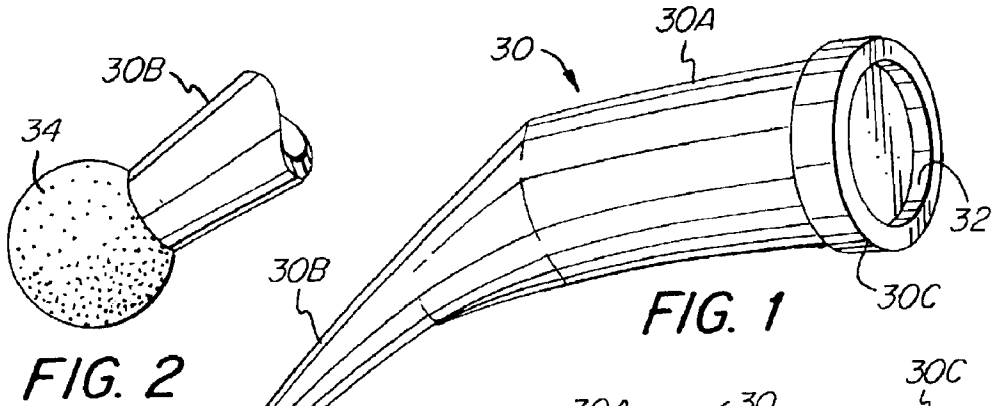
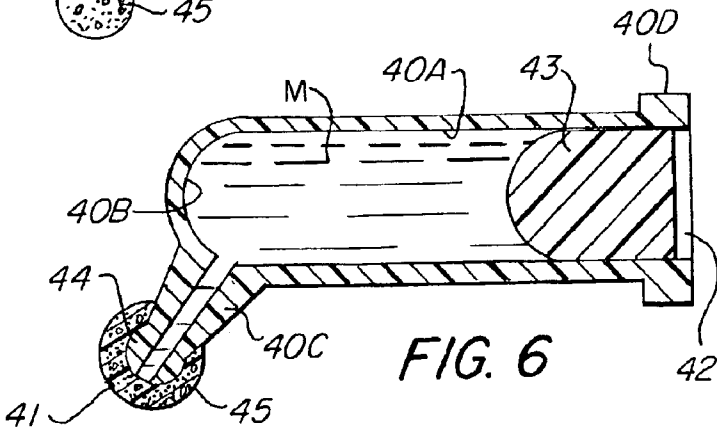
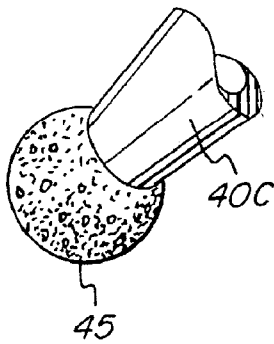
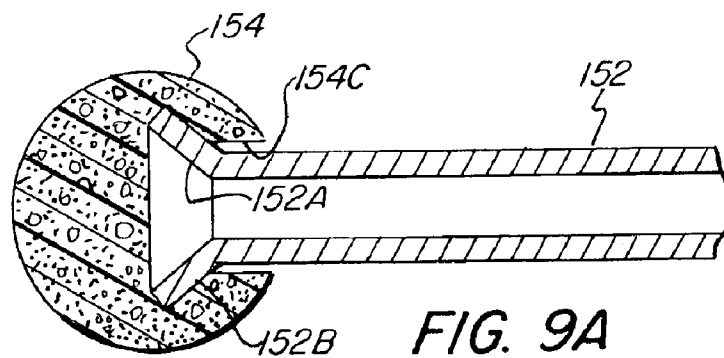
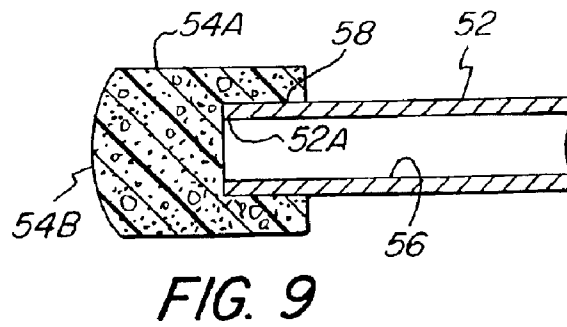
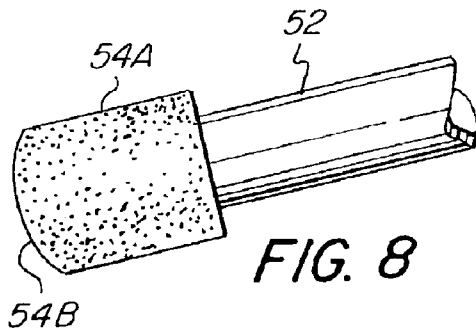
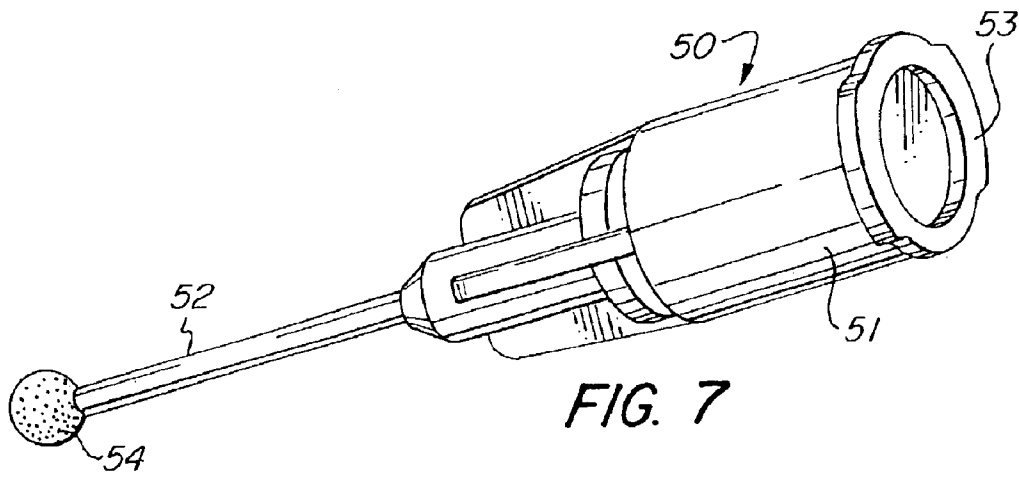

FIG. 5





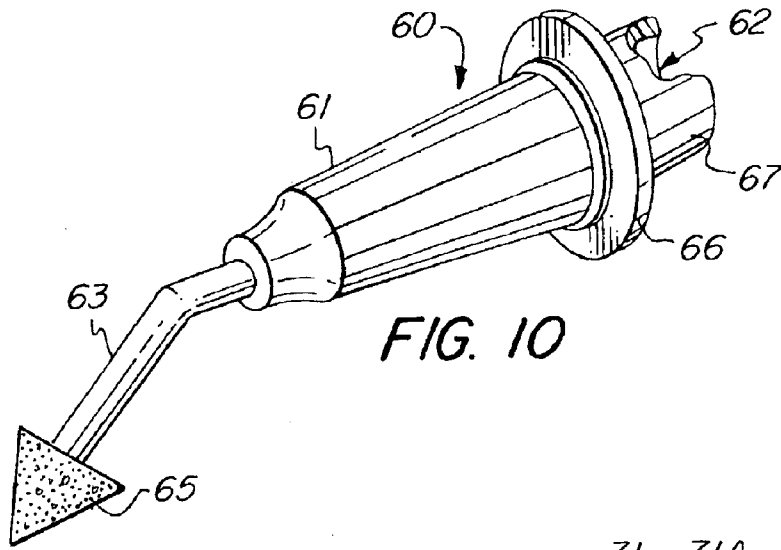

FIG. 10

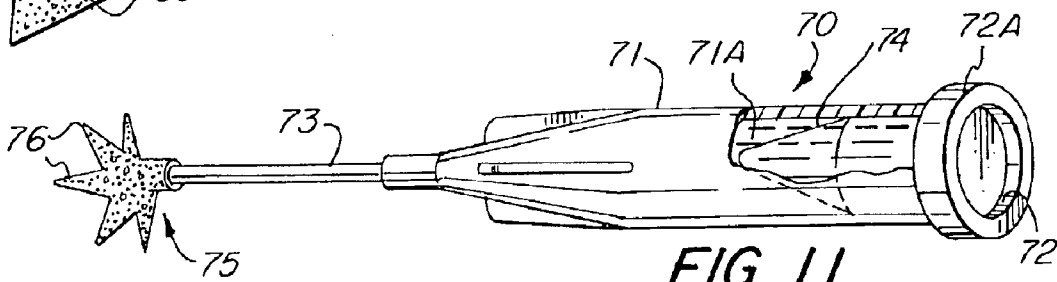

FIG. 11

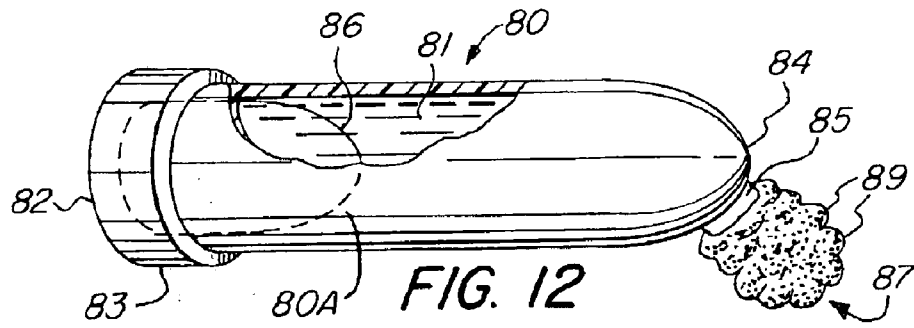

FIG. 12

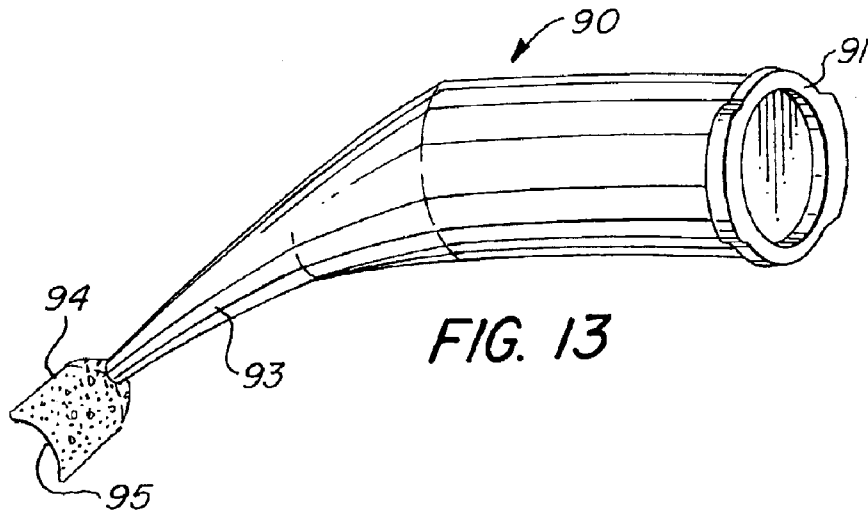
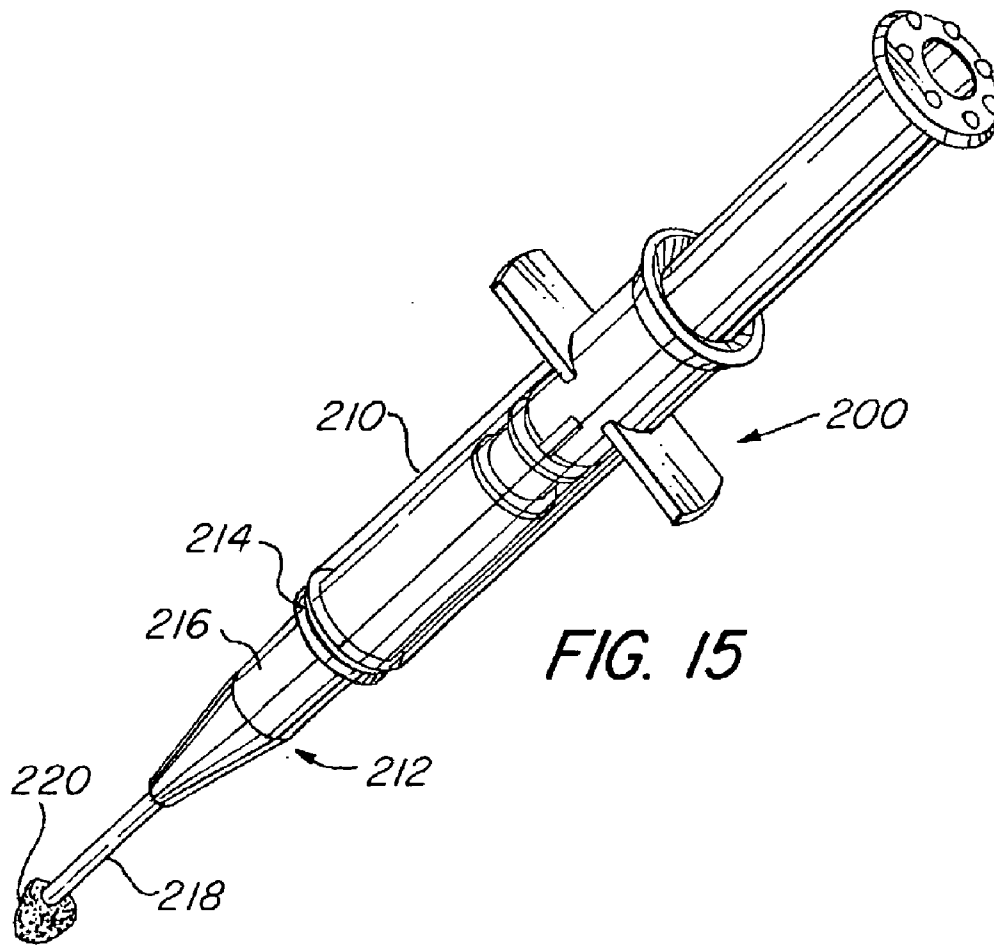
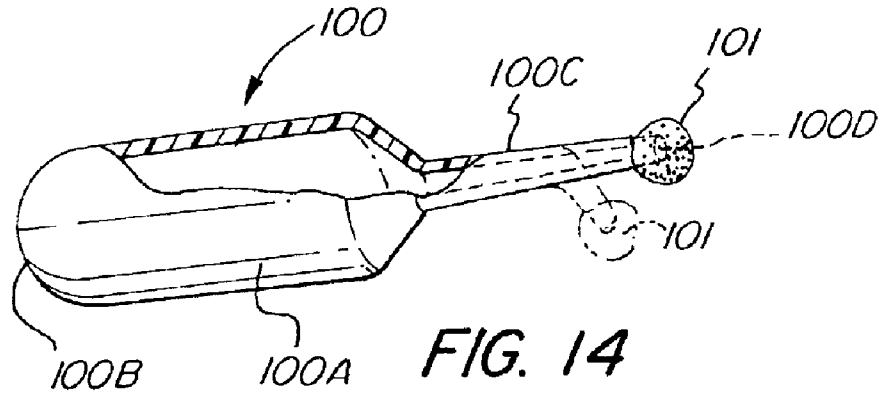

FIG. 13



DENTAL MATERIAL CONTAINER WITH POROUS FLOW THROUGH APPLICATOR

RELATED APPLICATION

This application is a continuation of patent application Ser. No. 09/906,369 filed Jul. 16, 2001 now U.S. Pat. No. 6,585,511, which is herein incorporated by reference in its entirety.

FIELD OF THE INVENTION

The invention relates generally to a dental container, capsule or nozzle used for applying relatively low viscosity or fluent dental materials onto a tooth, and more particularly to a capsule, nozzle or container for dispensing low viscosity dental material through a porous flow through applicator connected to the discharge orifice for evenly distributing and applying the low viscosity or fluent dental material directly onto a tooth as the material is being dispensed.

BACKGROUND OF THE INVENTION

Heretofore, high viscosity dental materials have been applied with the use of a dental capsule utilizing a displaceable piston or plug to force or express a high viscosity material out from the capsule through a discharge orifice. A syringe having a plunger is often used in combination with such capsule to displace the piston. In many dental applications, when a relatively low viscosity or very fluent material is to be applied, brushes have been used to apply the same. However, using a brush type applicator requires constant reapplication of the dental material to the brush. This is inconvenient and time consuming, and at times results in dripping or the placement of such low viscosity or fluent dental material in an inappropriate or even dangerous locations within the mouth. For example, various low viscosity dental materials, such as acid etch materials, are intended to be applied only to the tooth and may cause injury to the gum or other soft tissues if applied thereto.

Efforts have been made to overcome the problems encountered in the placement of low viscosity or fluent materials. One example of a dental dispenser or syringe for use in applying dental materials is disclosed in U.S. Pat. No. 5,816,804 entitled "Fiber Ended Open Orifice Delivery Tip" issuing to Fischer on Oct. 6, 1998. Therein disclosed is a delivery syringe having a plurality of small fibrous bristles disposed around an outer periphery of the nozzle adjacent the discharge orifice.

U.S. Pat. No. 6,059,570 entitled "Dental Container Type Applicator" granted to Dragan et al on May 9, 2000, which is herein incorporated by reference, discloses a dental container, capsule or nozzle that has minute fibers or flocking adhered about the external surface of a discharge nozzle in the vicinity of the discharge orifice, which permits the user to spread, burnish, or distribute dental material on a tooth as the material is being expressed from the capsule, nozzle or container.

While these prior applicator devices are suitable for applying certain dental materials, some difficulty has been encountered in achieving the desired control or consistent flow requirements often required in effecting proper tooth restoration and/or in performing other dental procedures requiring the use of low viscosity materials. Additionally, the difficulty in the placement of the minute or small fibers or bristles onto a nozzle has often resulted in irregular covering of such fibers onto the nozzle or discharge end of a cartridge to result in the possibility of scratching or

damaging the surface on which the material is to be applied. Therefore, there is a need for an improved, more easily manufactured and more reliable dental applicator for use in applying materials of relatively low viscosity by which such materials can be spread, burnished or distributed directly onto a tooth or other surface as the material is being dispensed from a capsule or syringe.

SUMMARY OF THE INVENTION

The invention is directed to a dental container, nozzle, or capsule for containing or dispensing a low viscosity dental material which includes a discharge end or orifice having a foam or porous flow through applicator or covering. In one embodiment the dental container includes a needle-like cannula through which the material is dispensed. The foam or porous flow through covering or applicator attached to the discharge end or orifice may take a variety of different shapes suitable for performing a prescribed procedure. The foam or porous covering is uniformly formed or connected to the discharge end for permitting an even, uniform flow of the dental material therethrough, as the material is being dispensed. The foam or porous flow through covering may be applied to the container or capsule during the molding process thereof and can be molded to any desired shape. In another embodiment, the foam or porous covering may be mechanically retained or adhered by suitable adhesive onto the discharge end of a capsule or cartridge.

Accordingly, it is an object of the present invention to provide an improved applicator for the application of low viscosity dental materials directly onto a tooth.

It is a further object of the present invention to provide a dental applicator having improved material flow characteristics.

It is an advantage of the present invention that the porous applicator end may be made in a variety of different shapes depending upon the dental procedure to be performed.

It is a further advantage of the present invention that the dental container or cartridge with flow through applicator can be produced with consistency and uniformity.

A feature of the present invention is that a foam or porous flow through cover is connected to the discharge end of the dental container or capsule to control the dispensing and application of a fluent or low viscosity dental material.

It is a further feature of the present invention that the discharge end of a dental capsule or cartridge may be of various shapes suitable for a particular procedure.

These and other objects, advantages, and features will become readily apparent in view of the following more detailed description.

BRIEF DESCRIPTION OF THE DRAWINGS

FIG. 1 is a perspective view of an embodiment of the present invention.

FIG. 2 is a partial view of the applicator or discharge end of the embodiment illustrated in FIG. 1.

FIG. 3 is a side elevational view in cross section of an embodiment of the present invention.

FIG. 4 is a perspective view of another embodiment of the present invention.

FIG. 5 is a partial view of the applicator or discharge end of the present invention illustrated in FIG. 4.

FIG. 6 is a side elevational view in cross section of another embodiment of the present invention.

FIG. 7 is a perspective view of another embodiment of the present invention.

3

FIG. 8 is a partial view of the discharge or applicator end of another embodiment of the present invention.

FIG. 9 is a cross sectional view of the applicator end or discharge end of the embodiment illustrated in FIG. 8.

FIG. 9A is a cross sectional view of a discharge portion of another embodiment of the present invention.

FIG. 10 is a perspective view of yet another embodiment of the present invention.

FIG. 11 is a perspective view in partial section of yet another embodiment of the present invention.

FIG. 12 is a perspective view with a partial section of yet another embodiment of the present invention.

FIG. 13 is a perspective view of yet another embodiment of the present invention.

FIG. 14 is a partially sectioned view of another embodiment of the present invention.

FIG. 15 is a perspective view of a syringe assembly illustrating an embodiment of the present invention.

DETAILED DESCRIPTION OF THE PREFERRED EMBODIMENTS

FIGS. 1-3 illustrate one embodiment of the present invention. FIGS. 1 to 3 illustrate a dental capsule 30 which is formed from any suitable plastic material having a generally cylindrical body portion 30A. The cylindrical body portion 30A defines a reservoir for containing a predetermined amount of relatively non-viscous, a low viscosity, or fluid dental material M. The dental material may comprise a sealant, cement, bonding agent, flowable composite or other dental material having a generally low viscosity or fluent consistency. The dental capsule or cartridge 30 has a rear open end 32 and an opposite discharge end 31. A flange 30C is placed adjacent the rear open end 32. A piston 33 is freely displaceable within the body portion 30A and seals opening 32. The tapering discharge nozzle end 30B provides a relatively smooth transition zone from the larger diameter body portion 30A to the smaller diameter discharge orifice 31. Attached to the discharge nozzle 30B and surrounding the orifice 31 is a covering 34 of a porous material such as a sponge, open cellular foam, or the like, by which the material being dispensed can flow therethrough and by which the material may be spread, burnished or brushed directly onto a tooth as it is being dispensed. The open cellular covering 34 may be formed by molding the same during the molding of the capsule or cartridge 30, or may be attached thereto by a suitable adhesive or by mechanical means. When molded, the open cellular covering 34 bonds to the discharge nozzle without the need for glue or adhesive. The covering 34 may be made of any cellular or foam-like material that is porous, e.g. a natural or synthetic sponge, plastic foam or other open cellular or porous material. The porosity of the covering 34 may be matched to the viscosity of the material M. That is, if the material M being dispensed is somewhat less fluent, the foam or covering 34 may be provided with larger pores or openings so as to permit such less fluent material to flow therethrough in a controlled manner. If the material M being dispensed is less viscous, the covering 34 may be formed with smaller openings or pores to control the flow therethrough. Therefore, the flow characteristics of the material M may be controlled accurately and in a consistent manner depending upon the viscosity of the material being dispensed there-through.

FIGS. 4-6 illustrate another embodiment of the present invention. In this embodiment, a cartridge or capsule 40

4

comprises an elongated cylinder body portion 40A defining a reservoir for containing a supply of low viscosity dental material M. An end wall 40B is formed at one end, which is illustrated as being hemispherical. However, it will be understood that the end wall 40B may take other shapes well known and/or as disclosed in a number of prior capsule patents. Adjacent the end wall 40B and extending at an angle relative to the central axis of the body portion 40A is a discharge nozzle 40C. The discharge nozzle or cannula 40C communicates with the body portion 40A. The nozzle 40C terminates in a ball tip or sphere 44 which includes a discharge orifice 41. A displaceable piston 43 is placed at the open end 42 for sealing the open end 42 and for extruding the dental material when displaced. A flange 40D generally circumscribes the open end 42. A porous cover or applicator 45 is secured about the small sphere 44 at the end of the discharge nozzle 40C. The small sphere 44 provides support for the porous cover 45 and facilitates the spreading or brushing of the dental material onto a tooth surface.

FIG. 7 illustrates another embodiment of the present invention. In this embodiment, the dental tip, cartridge or capsule 50 is utilized as a delivery nozzle which may be directly attached to the end of a syringe (not shown) containing a quantity of low viscosity material to be dispensed through the dental tip 50. The dental tip 50 comprises a body portion 51 and a connected needle-like cannula 52 having a bore 56. The cannula 52 is connected to one end of the body 51 through which the dental material is discharged. A Luhr locking flange 53 is formed on the other end of the body 51. The Luhr locking flange 53 is constructed to releaseably mate and lock the tip 50 onto the end of a syringe, not shown, or other container defining a reservoir for the dental material. The needle cannula 52 is generally formed of metal, but can also be made of any suitable material, such as plastic. The cannula 52, when formed of metal, is preferably formed of a ductile metal which can be bent so that the discharge end or orifice may be disposed at any desired angle relative to the longitudinal axis of the body 51. A foam or porous flow through cover 54 is attached to the cannula 52. The flow through cover or applicator may be made of any type of porous material that has the desired porosity as hereinbefore described. In the illustrated embodiment, the porous covering 54 is illustrated as being spherical in shape.

FIG. 8 illustrates another embodiment of the present invention similar to that illustrated in FIG. 7. However, FIG. 8 illustrates only the applicator or discharge end of the embodiment. Attached to cannula 52 is a porous cover in the shape of a cylindrical shaped applicator circumscribing the discharge orifice 52A. The cylindrical applicator of foam or flow through cellular material 54A is provided with a recessed portion 58 by which it is fitted to the orifice end 52A of the cannula 52. The foam cylindrical applicator 54A may have a curved surface 54B formed at distal end.

FIG. 9 illustrates the embodiment illustrated in FIG. 8 in cross section. The foam cylindrical applicator 54A is attached to the cannula 52 as hereinbefore described. The recessed end portion 58 may be coated with a suitable adhesive so that the cylindrical applicator 54A is securely attached thereto. The foam cylindrical applicator 54A is snugly fitted to the end of the bore 56 of the cannula 52. Accordingly, dental material may freely flow from the orifice 52A and through the porous or foam cylindrical applicator 54A.

FIG. 9A illustrates an embodiment of the present invention having a mechanical holding feature for attaching the foam or porous covering or applicator 154 to the cannula 152.

5

A cannula **152**, which may be made of plastic or metal, is attached to a body portion of the capsule or cartridge as hereinbefore described. In the illustrated embodiment, the cannula **152** has an outwardly flare or mechanical retainer **152A** formed at the discharge end. The foam applicator or cover **154** has a complementary shaped internal cavity **152B**. The internal cavity **152B** need only have a complementary shape to that of the flared retainer **152A** so as to mechanically retain the foam applicator **154** onto the flare or mechanical retainer **152A** of the cannula **152**. For additional securement, a glue or suitable adhesive may also be used. The resiliency of the foam applicator **154** helps to hold the foam cover **154** on the cannula **152** which, in FIG. **9A**, the cover **154** is illustrated as having a spherical shape. However, it will be understood that the shape may vary depending upon the use thereof. Additionally, the mechanical retainer **152A** may have other desired shapes as long as the shape functions to mechanically hold the foam or porous flow through applicator **154** onto the cannula **152**. The embodiment of FIG. **9A** has the further advantage that different shaped foam applicators **154** may be selected for placement onto the discharge end of cannula **152**, depending upon the application or preference of the user.

FIG. **10** illustrates another embodiment of the present invention. In FIG. **10**, a dental cartridge, capsule or tip **60** includes a body portion **61** provided with a rear opening **62** at one end and a needle-like cannula **63** connected to the other end thereof. At the end of the needle like cannula **63** is a foam or porous flow through cover in the form of a cone defining an apex **65**. The conically shaped cover **65** may be adhered to the cannula **63** by any of the means hereinbefore described. The tip **60** has a flange **66** and a nipple portion **67** adjacent thereto. The dental tip **60** is formed so as to be detachably connected to a syringe or container containing the dental material. It will be understood that the foam end **65** may assume other desired shapes. The conical shape terminating in a pointed apex provides for precise placing of the dental material flowing through the applicator end **65**.

FIG. **11** illustrates yet another embodiment of the present invention. The dental capsule **70** is illustrated as having an elongated cylindrical body portion **71** which has an open end **72** and an elongated needle like cannula **73** at the other end. An outwardly extending flange **72A** circumscribes the open end **72**. A displaceable piston **74** seals the open end **72**. A reservoir **71A** contains low viscosity dental material. Attached to the discharge end of cannula **73** is a foam or porous flow through applicator **75**. The foam or flow through applicator **75** is formed with a plurality of fingers or points **76**.

FIG. **12** illustrates yet another embodiment of the present invention. The dental capsule, cartridge or tip **80** comprises an elongated, cylindrical or tubular body **80A** defining a reservoir **81** for containing a predetermined amount of low viscosity dental material. One end of the body **80A** has an opening **82**. A radially extending flange **83** circumscribes opening **82**. The other end of the body **80A** is provided with a conical end wall **84**. Extending at an angle relative to the end wall **84** is a discharge nozzle **85** having a discharge orifice. The displaceable piston **86** is provided with a conical shape end which complements the interior configuration of the end wall **84** and seals opening **82**. A shaped foam or porous flow through applicator **87** is attached to the orifice end of the discharge nozzle **85**. The shaped foam applicator **87** has a plurality of appendages **89** formed thereon. These appendages **89** assist in spreading or coating the dental material onto a tooth or other dental surface as the dental material is dispensed therethrough.

6

FIG. **13** illustrates yet another embodiment of the present invention. In this embodiment, tip, cartridge or capsule **90** has a Luhr type locking flange **91** on one end and a discharge nozzle **93** connected to the other end. Attached to the discharge nozzle **93** is a foam or porous flow through applicator **94** having a concave portion **95** to conform to the shape of a tooth whereby the dental material dispensed therethrough may be spread or brushed onto a tooth in broad strokes.

FIG. **14** illustrates yet another embodiment of the present invention directed to a sealed dental container or ampule that is squeezable. The dental container or ampule **100** has a body portion **10A**, which is closed at one end. **100B**. The other end terminates in an elongated discharge nozzle **100C** having a distal end which is also initially sealed. The body **100A** of the ampule **100** is preferably formed of a flexible plastic material whereby the body portion **100A** functions in the nature of a squeeze bottle. Disposed within the body portion **100A** is a predetermined amount of low viscosity dental material. The dental material may be a fluent gel or liquid. The discharge nozzle **100C** is flexible and may be bent into a desired position as illustrated in phantom in FIG. **14**. Covering the discharge end of the discharge nozzle **100C** is a foam or porous flow through cover or applicator **101** in the form of a ball. The closed or sealed end **100D** of the discharge nozzle **100C** may be pieced by a suitable piecing tool to form a discharge orifice through which the dental material may be dispensed as it flows through the porous cover **101**.

FIG. **15** illustrates another embodiment of the present invention. In this embodiment a syringe assembly **200** comprises a syringe body **210** with an attached replaceable cartridge or tip **212**. The tip **212** comprises a locking flange **214**, a body portion **216**, a small discharging tube or cannula **218** provided with a discharge orifice. Surrounding the discharge orifice is a foam or porous flow through applicator **220**. The locking flange **214** is adapted to attach the tip **212** to the open or discharge end of the syringe **210**. This permits the dispensing of bulk low viscosity material placed within the syringe **210** with the use of multiple individual tips **212**. Therefore, the bulk material may be dispensed in small quantities at different times through the replaceable tips **212**. At each different time or use of the syringe **210**, a new applicator tip **212** may be used. It will be understood that the tip **212** may be secured to the syringe by various means, such as press fit, screw threads, bayonet fittings, Luhr locking flange, and/or other equivalent attaching systems.

It should be appreciated that the present invention provides a dental material container, capsule, nozzle or ampule with a flow through applicator having improved flow control characteristics enabling low viscosity material to be dispensed. Additionally, the foam or porous flow through applicator of the different embodiments takes a variety of shapes. Each of the shapes may be molded as desired during the manufacturing process of the tip, cartridge, capsule or container. Alternatively, the foam or porous flow through cover or applicator may be adhered to the tip, cartridge, capsule or container by suitable adhesives and/or mechanically attached. The present invention having a foam applicator end can be easily manufactured and provides for a more consistent and controllable flow characteristic than prior known brush or flock type applicators. Additionally, the foam or porous flow through applicator ends of the various embodiments of the present invention provides for a more consistent applying surface and which imparts a cushioning effect to prevent scratching or damaging the surface on which the material is being applied. Therefore,

7

the present invention in its various embodiments provides a considerable improvement over applicators previously known and used.

While the present invention has been described with respect to various dental type embodiments, other modifications, variations and uses thereof may be made without departing from the spirit and scope of this invention.

What is claimed is:

1. A bulk syringe for dispensing a low viscosity dental material comprising:

a syringe body containing a bulk supply of a predetermined amount of low viscosity dental material and having a discharge end;

a nozzle having a cannula with a discharge orifice detachably attached to the discharge end of said syringe body; and

a foam flow through material attached to the discharge orifice and only a portion of the cannula and completely covering said discharge orifice, whereby the low viscosity dental material in said syringe is capable of being dispensed through said foam flow through material to control the flow of said low viscosity dental material during the dispensing thereof.

2. A bulk syringe as defined in claim 1 wherein: said foam flow through material is bonded to said nozzle.

3. A bulk syringe as defined in claim 1 wherein: said nozzle is detachably connected to said syringe body.

4. A bulk syringe for dispensing a low viscosity dental material comprising:

a syringe body containing a bulk supply of a predetermined amount of low viscosity dental material and having a discharge end;

8

a tip having a body portion and a discharge cannula having a discharge orifice, said tip detachably attaching to the discharge end of said syringe body; and

a foam flow through material attached to and externally surrounding the discharge orifice and an exterior portion of the discharge cannula and completely covering said discharge orifice, whereby the low viscosity dental material in said syringe body is capable of being dispensed through said foam flow through material to control the flow and application of the low viscosity dental material during the dispensing thereof.

5. A method of dispensing a low viscosity dental material with a bulk syringe comprising the steps of:

placing the low viscosity dental material in a syringe body having a discharge end;

attaching a tip having a body portion and a discharge cannula with a foam flow through material attached to and externally surrounding the discharge orifice and an exterior portion of the discharge cannula and completely covering said discharge orifice;

forcing the low viscosity dental material in the syringe body from the discharge end into the tip and through the foam flow through material;

applying the low viscosity dental material to a dental surface; and

burnishing the dental surface with the foam flow through material,

whereby the dental material is controllably applied to the dental surface.

* * * * *