



US0D1033277S

(12) **United States Design Patent**  
**Kottmann**

(10) **Patent No.:** **US D1,033,277 S**

(45) **Date of Patent:** **\*\* Jul. 2, 2024**

(54) **MOTORCYCLE, TOY, AND/OR REPLICAS THEREOF**

(71) Applicant: **Bayerische Motoren Werke Aktiengesellschaft, Munich (DE)**

(72) Inventor: **Matthias Sebastian Kottmann, Munich (DE)**

(73) Assignee: **Bayerische Motoren Werke Aktiengesellschaft, Munich (DE)**

(\*\*) Term: **15 Years**

(21) Appl. No.: **29/853,850**

(22) Filed: **Sep. 20, 2022**

(30) **Foreign Application Priority Data**

Mar. 21, 2022 (DE) ..... 402022100249.1

(51) **LOC (14) Cl.** ..... **12-11**

(52) **U.S. Cl.**  
USPC ..... **D12/107; D21/432**

(58) **Field of Classification Search**  
USPC ..... D12/107, 110, 111, 117; D21/432, 538  
CPC ..... B62K 11/00; B62K 11/02; B62K 11/04;  
B62K 11/10; B62K 17/00; B62K 19/00;  
B62K 2022/00

See application file for complete search history.

(56) **References Cited**

**U.S. PATENT DOCUMENTS**

D392,600 S	3/1998	Robb et al.	
D591,205 S	4/2009	Heinrich et al.	
D597,449 S *	8/2009	Nagao	D12/110
D601,458 S *	10/2009	Nagao	D12/110
D606,457 S *	12/2009	Tanaka	D12/110
D647,824 S *	11/2011	Kouchi	D12/110
D647,825 S *	11/2011	Shibuta	D12/110
D670,204 S *	11/2012	Yasuhara	D12/110

D688,982 S *	9/2013	Oyanagi	D12/110
D689,406 S *	9/2013	Yasuhara	D12/110
D694,673 S *	12/2013	Katagiri	D12/110
D723,431 S *	3/2015	Noguchi	D12/110
D735,085 S	7/2015	Buckan	
D755,084 S *	5/2016	Sakata	D12/110
D756,268 S *	5/2016	Yamada	D12/110
D758,923 S *	6/2016	Yamada	D12/110
D795,746 S *	8/2017	Akita	D12/110

(Continued)

**OTHER PUBLICATIONS**

BMW Unveils Updated 2023 M 1000 RR, Oct. 11, 2022, Road Racing World Motorcycle Webpage [online], [Site Visit Nov. 7, 2023], URL: <https://www.roadracingworld.com/news/bmw-unveils-updated-2023-m-1000-rr/> (Year: 2022).\*

(Continued)

*Primary Examiner* — Calvin E Vansant  
*Assistant Examiner* — Giang Hoang Tran  
(74) *Attorney, Agent, or Firm* — Crowell & Moring LLP

(57) **CLAIM**

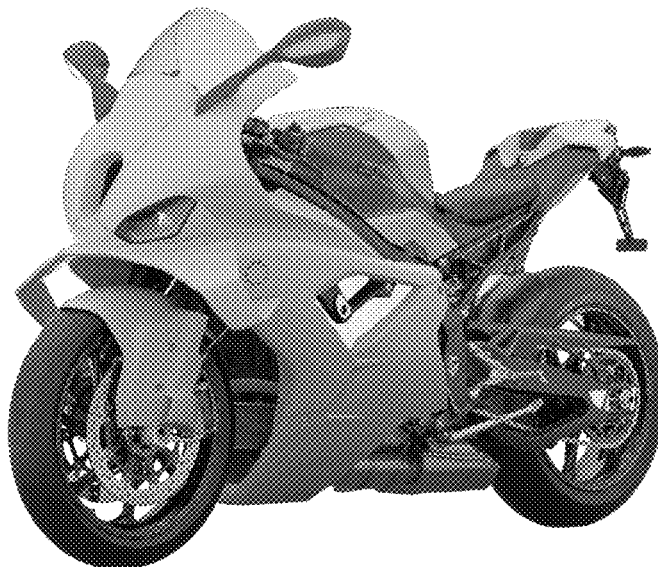
The ornamental design for a motorcycle, toy, and/or replicas thereof, as shown and described.

**DESCRIPTION**

FIG. 1 is a left, front perspective view of a motorcycle, toy, and/or replicas thereof according to the design;  
FIG. 2 is a left side view thereof;  
FIG. 3 is a right side view thereof;  
FIG. 4 is a front view thereof;  
FIG. 5 is a rear view thereof;  
FIG. 6 is a top view thereof; and,  
FIG. 7 is a bottom view thereof.

The portions in the drawings that are shown in a light tonal contrast illustrate portions of the motorcycle, toy, and/or replicas thereof that form no part of the claimed design.

**1 Claim, 7 Drawing Sheets**



(56)

**References Cited**

U.S. PATENT DOCUMENTS

D797,002	S	*	9/2017	Toyama	.....	D12/110
D801,230	S	*	10/2017	Endo	.....	D12/110
D860,059	S	*	9/2019	Kottmann	.....	D12/110
D884,562	S	*	5/2020	Usami	.....	D12/110
D914,546	S		3/2021	Martin		
D958,700	S		7/2022	Selosse		

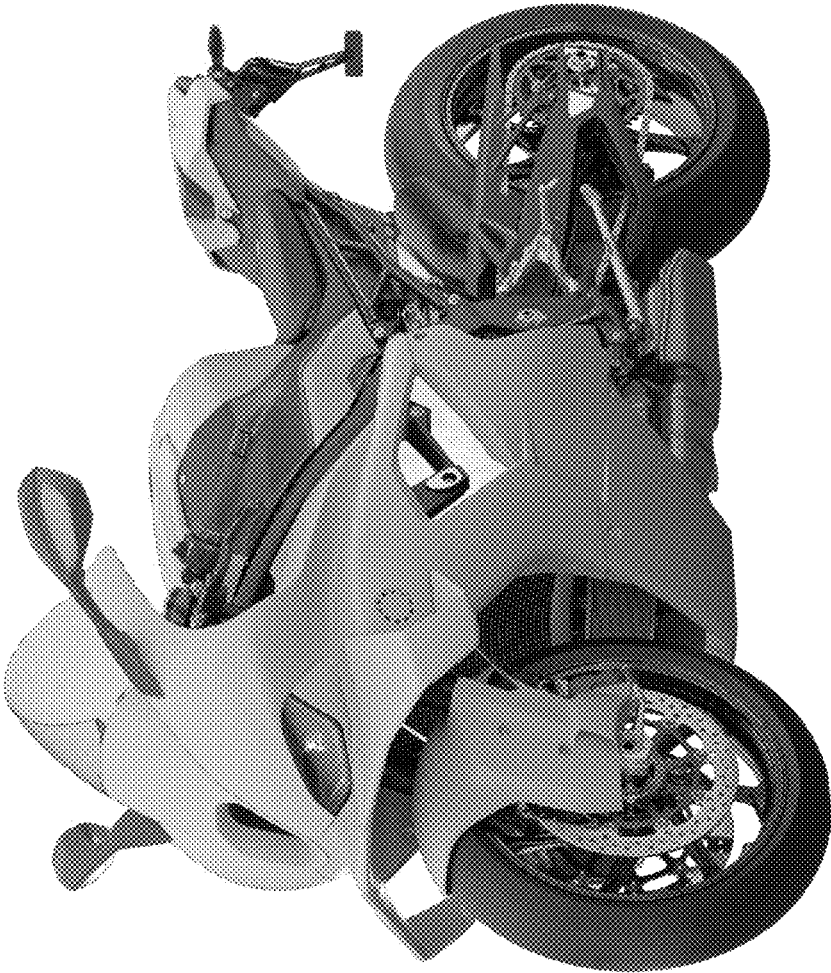
OTHER PUBLICATIONS

New 2023 BMW M 1000 RR—First Look Prices Specs, Oct. 13, 2022, YouTube [online], [Site Visit Nov. 7, 2023], URL: <https://www.youtube.com/watch?v=NMNjt-dRdDU> (Year: 2022).\*

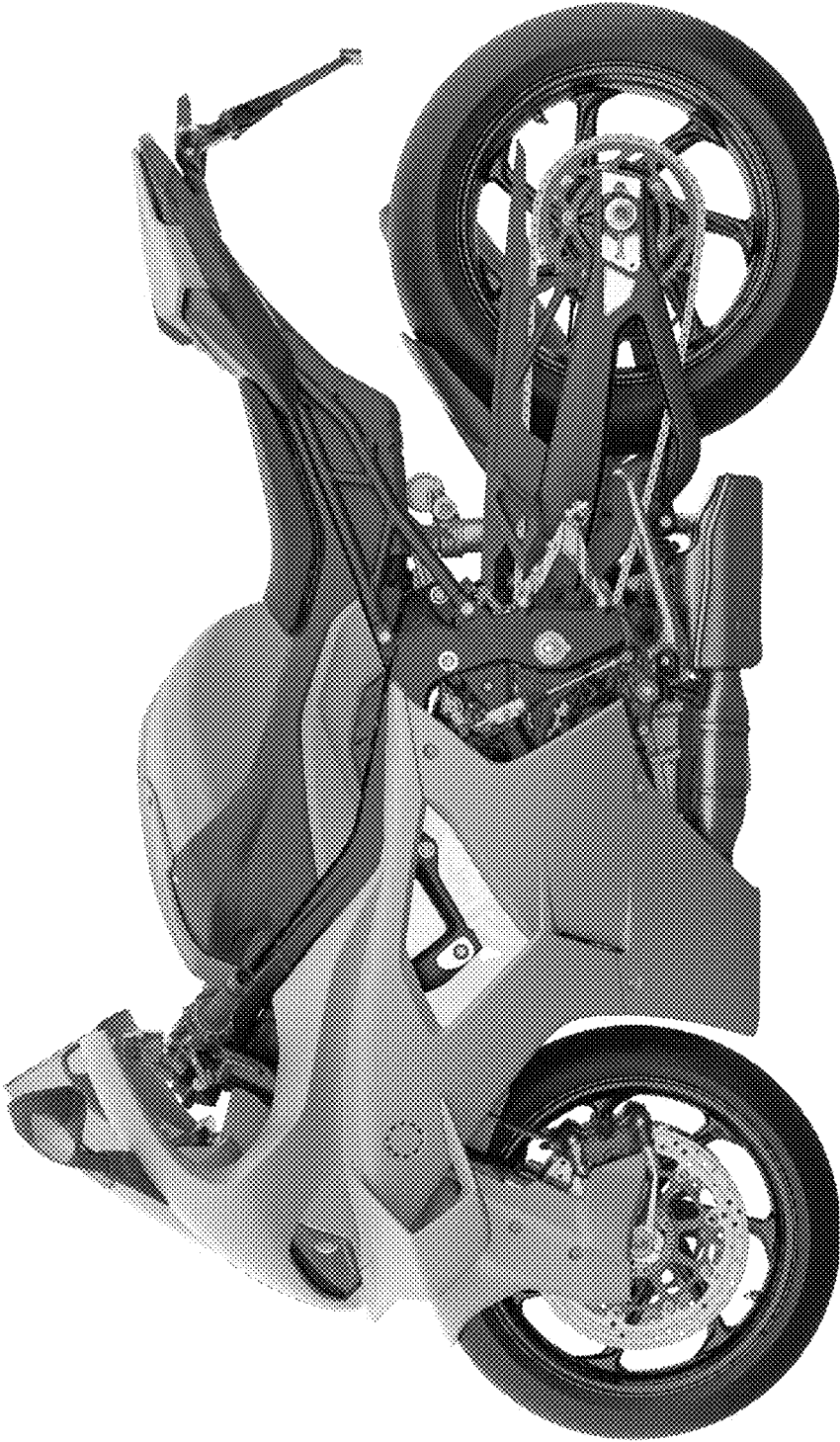
“The new BMW M 1000 RR,” Pressclub Global—Article, <https://www.press.bmwgroup.com/global/article/detail/T0316692EN/the-new-bmw-m-1000-rr?language=en>, Sep. 23, 2020, 9 pages, BMW Group, Germany.

Japanese-language Office Action issued in counterpart Japanese Application No. 2022-020094 dated Feb. 21, 2023 with partial English translation (6 pages).

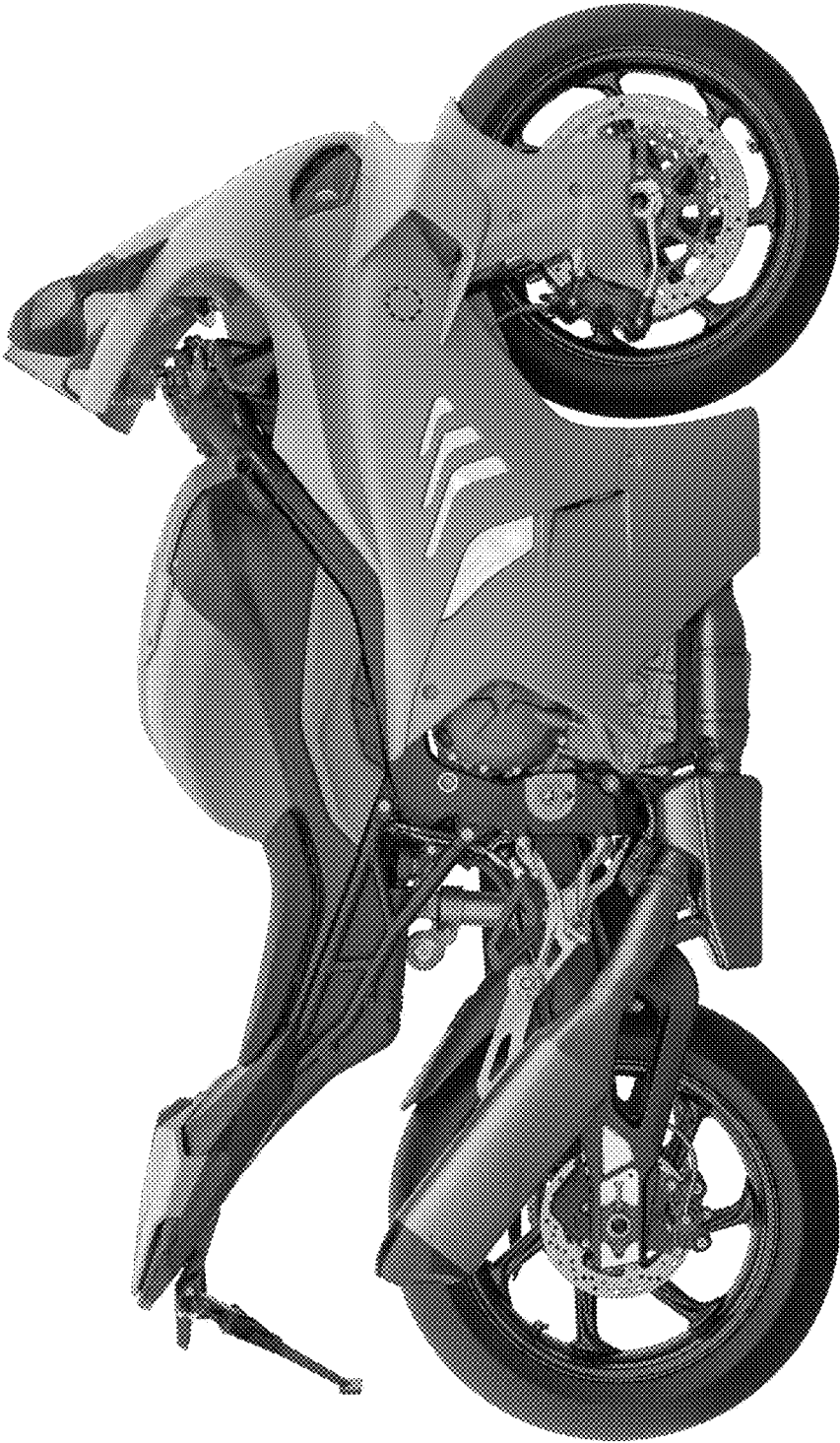
\* cited by examiner



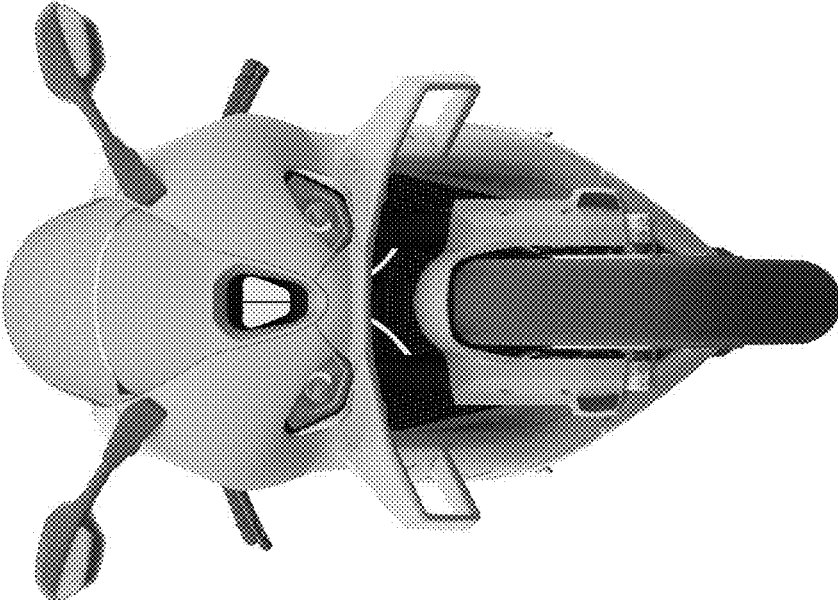
**FIG. 1**



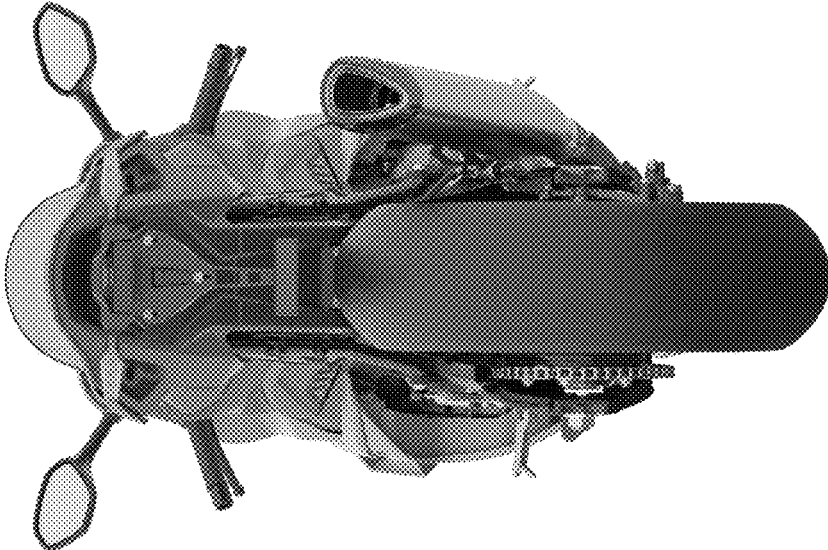
**FIG. 2**



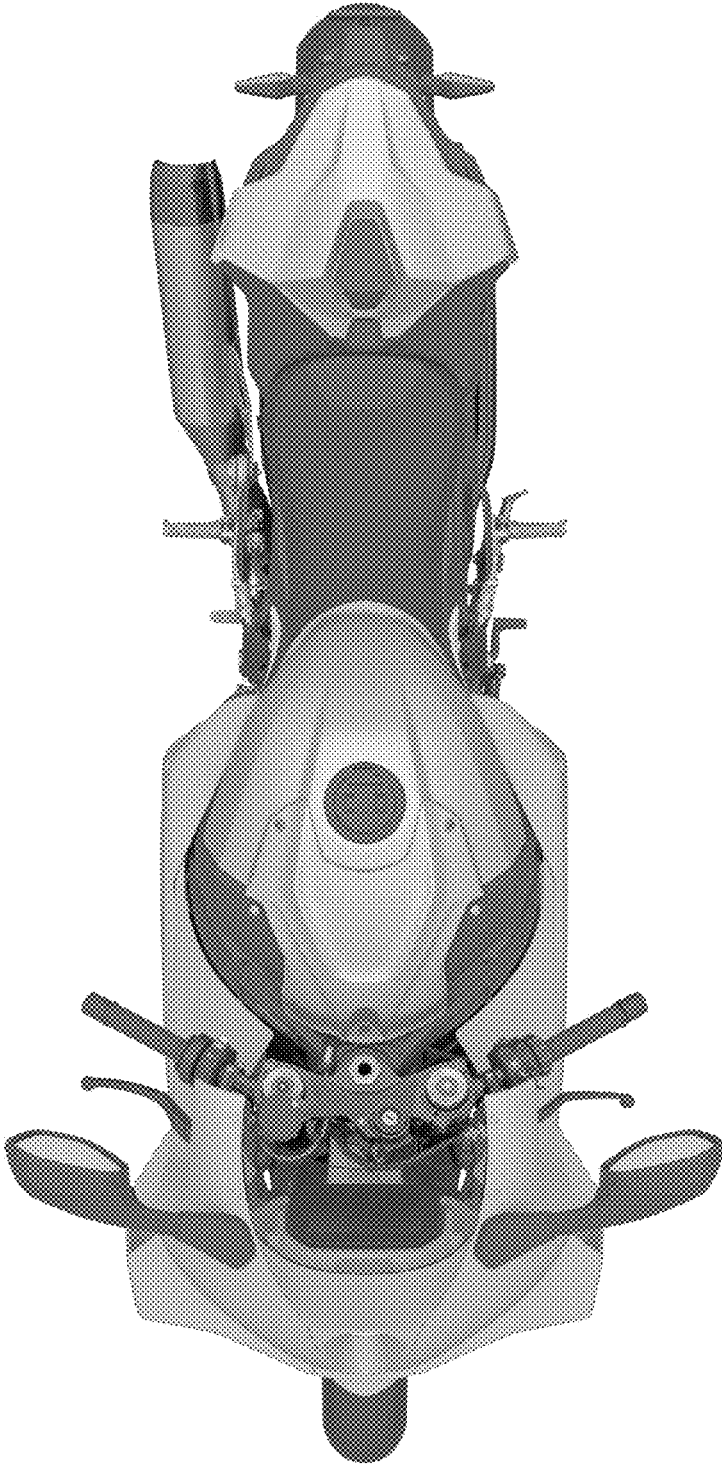
**FIG. 3**



**FIG. 4**

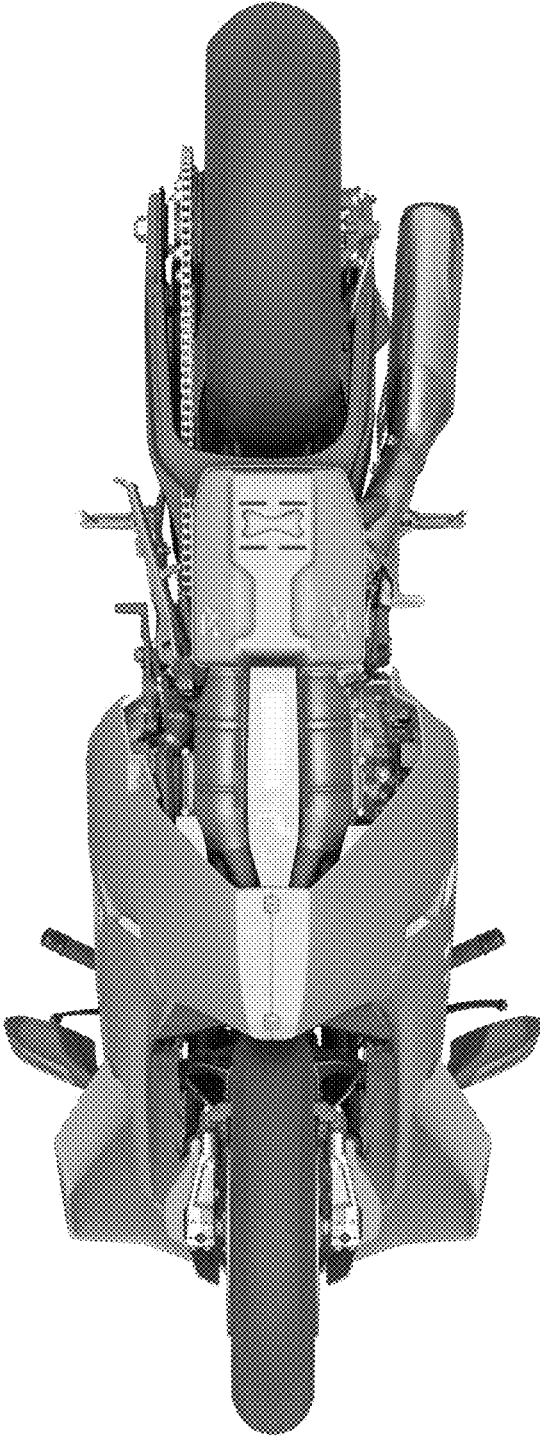


**FIG. 5**



**FIG. 6**





**FIG. 7**