

(19)
(12)

(KR)
(B1)

(51) 。 Int. Cl.7
B66C 23/88

(45)
(11)
(24)

2004 10 12
10-0452402
2004 10 01

(21) 10-2002-0037964
(22) 2002 07 02

(65)
(43)

10-2004-0003301
2004 01 13

(73) 2가 310

(72) 1 106-1606

3 101-702

101-304

2 289-4127/2

(74)

:

(54)

1
 2 1 ,
 3 ,
 4 ,
 5 4 ,
 6 .

< >

1: 2:
 3: 4:
 10: 11:
 20: 21,22:
 23: 23a,23b:

가

가 가 () ()
 가 가 () 가

1 3 T 가 가 (10)
 (13) (11), (14) (11) (12)
 (15), (11)
 (16),
 (17),
 () (10) (1)
 (PIT)(2) (10) ()
 (2) (11) (3) () H
 (3) (3) (COLLAR)(4)가
 (2) (3) (4)
 (3) (4) 가
 가 가

4
6
(20) (20) (11) (11) (20) (21)가 (21)가 (21)(22)가 (23)
) (23) (23a)(23b)가 가
(23) (20) (2) (3) (4)
(11) (10) (20) (20) (10)
(23) (11) (22) (23) (20) (11) (20) (21)
(23) (23a)(23b)가 (10)
가 (11) (20) (20)
(3) (4) (2)

가

(57)

1.

2.

1 (20) (20) (11) (11) (20) (21)가 (21)(22)

)가 (23)

3.

1 (23) , , , ,

4.

1 (23) , (23)

(20) (2)

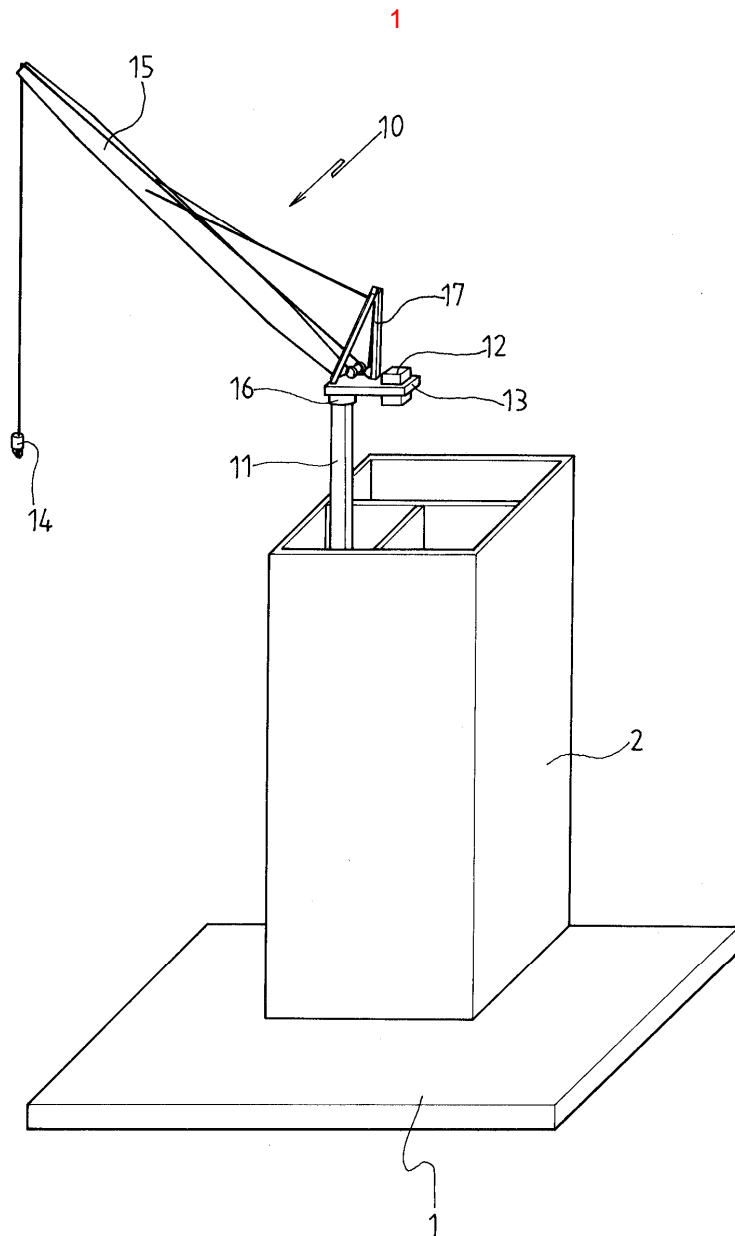

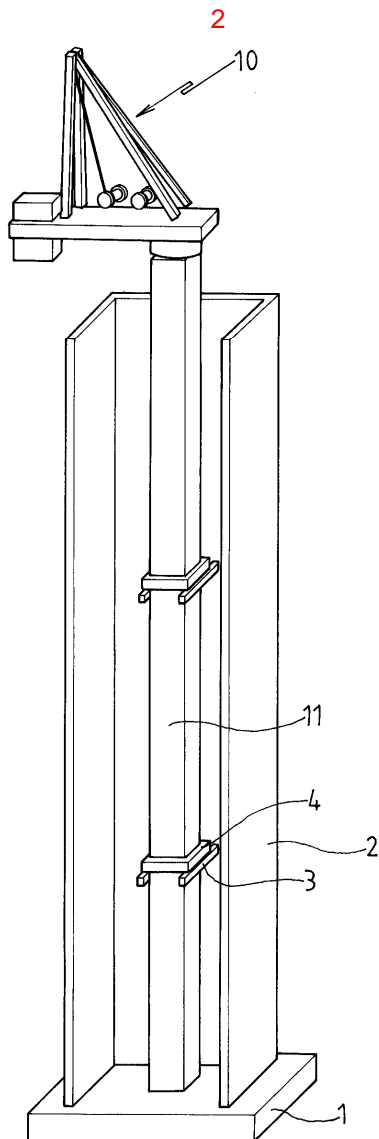

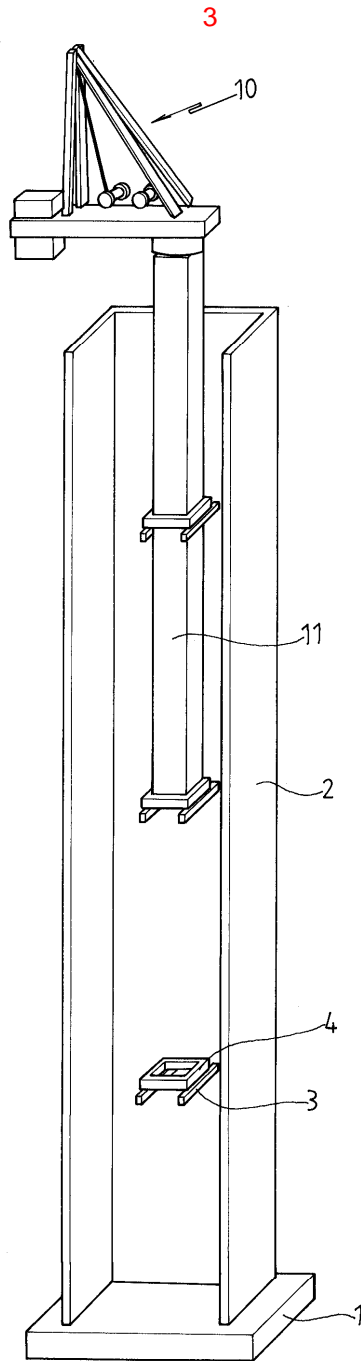

4

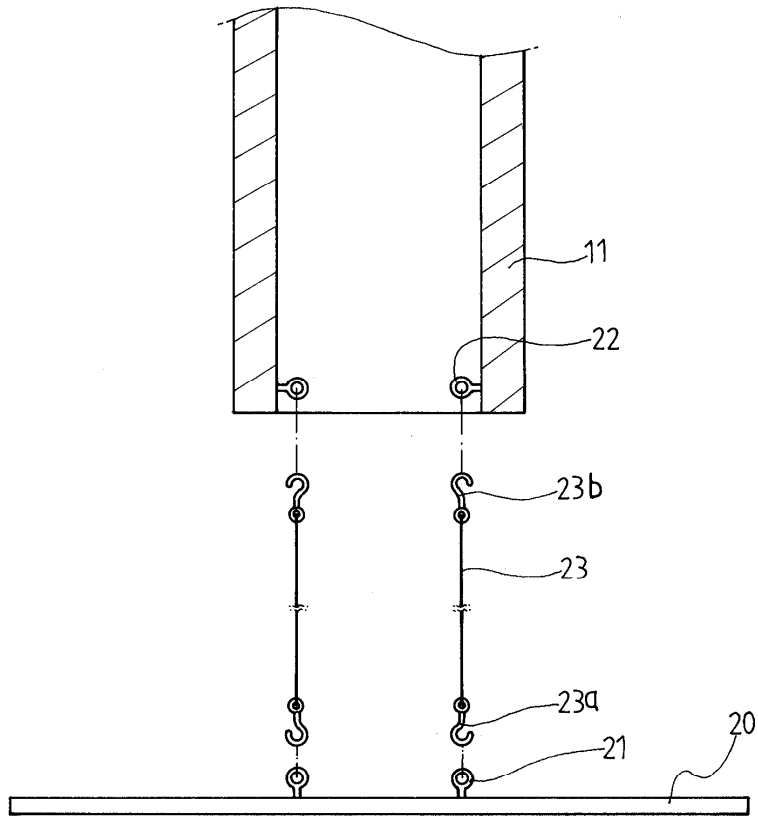

5

