



US 20130123757A1

(19) **United States**

(12) **Patent Application Publication**
Crisostomo et al.

(10) **Pub. No.: US 2013/0123757 A1**

(43) **Pub. Date: May 16, 2013**

(54) **DIRECT CONNECT FLUSH SYSTEM**

Publication Classification

(71) Applicant: **BOSTON SCIENTIFIC SCIMED, INC.**, Maple Grove, MN (US)

(51) **Int. Cl.**
A61B 17/00 (2006.01)

(72) Inventors: **Crissly V. Crisostomo**, Roseville, CA (US); **Randy S. Gamarra**, Sunnyvale, CA (US); **Takashi Ino**, San Jose, CA (US); **Benjamin Sutton**, San Jose, CA (US); **David J. Paul**, Scotts Valley, CA (US)

(52) **U.S. Cl.**
CPC **A61B 17/00** (2013.01)
USPC **606/1**

(73) Assignee: **BOSTON SCIENTIFIC SCIMED, INC.**, Maple Grove, MN (US)

(57) **ABSTRACT**

(21) Appl. No.: **13/668,372**

A medical device may include a handle housing having a side wall defining an interior space and proximal and distal apertures extending through the side wall, an elongated outer sheath, an elongated inner member, a proximal flush port disposed within the interior space and in fluid communication with the elongated inner member, and a distal flush port disposed within the interior space and in fluid communication with the elongated outer sheath. A control knob may be rotated to move the distal flush port within the interior space.

(22) Filed: **Nov. 5, 2012**

Related U.S. Application Data

(60) Provisional application No. 61/558,095, filed on Nov. 10, 2011.

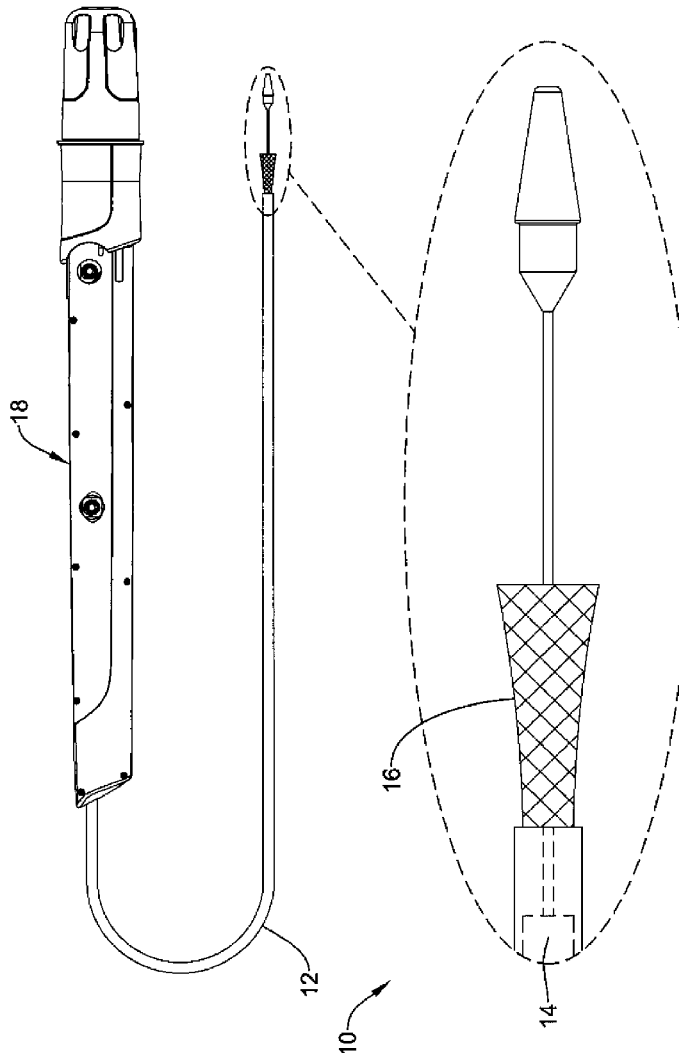

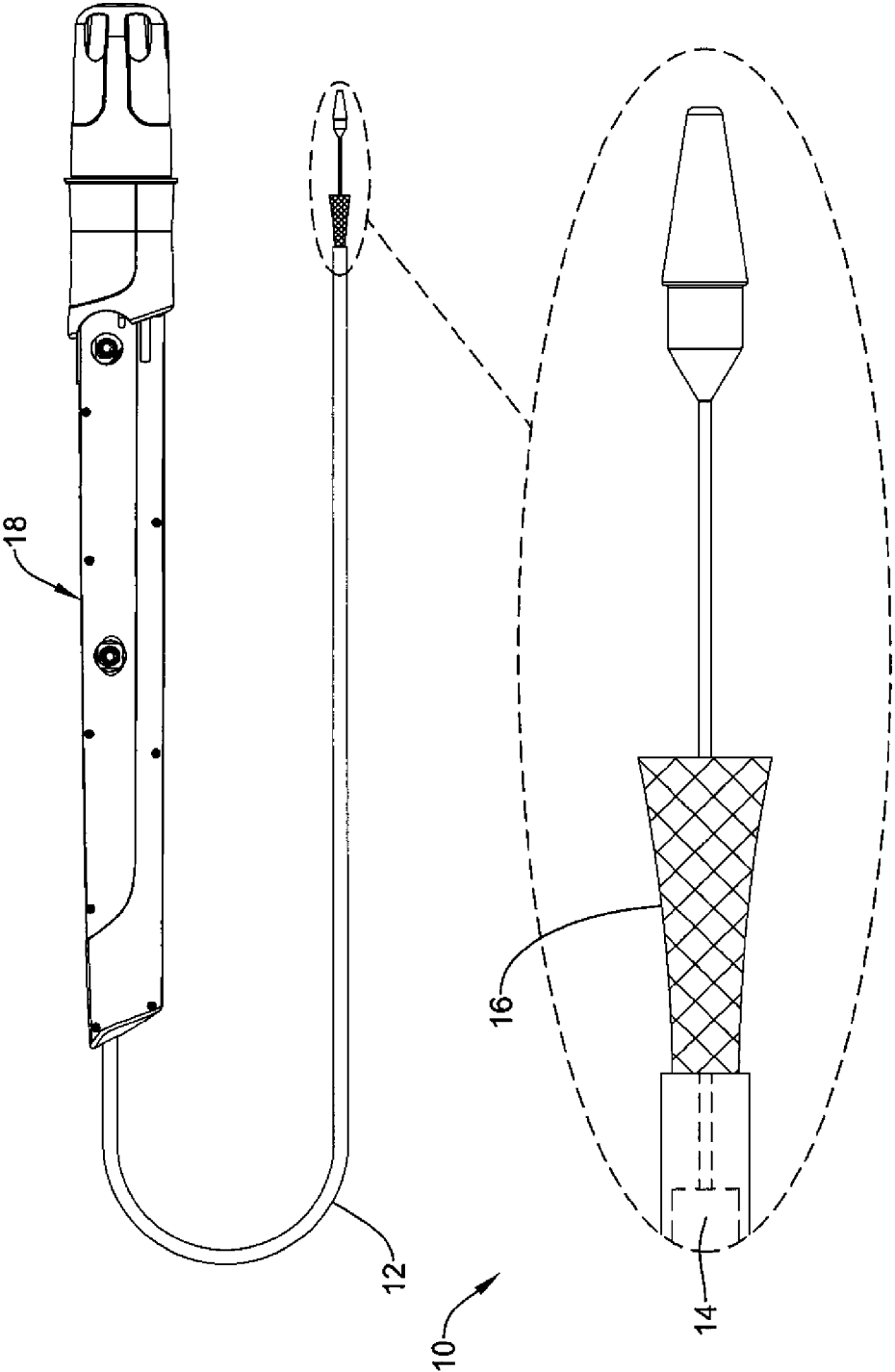

Figure 1

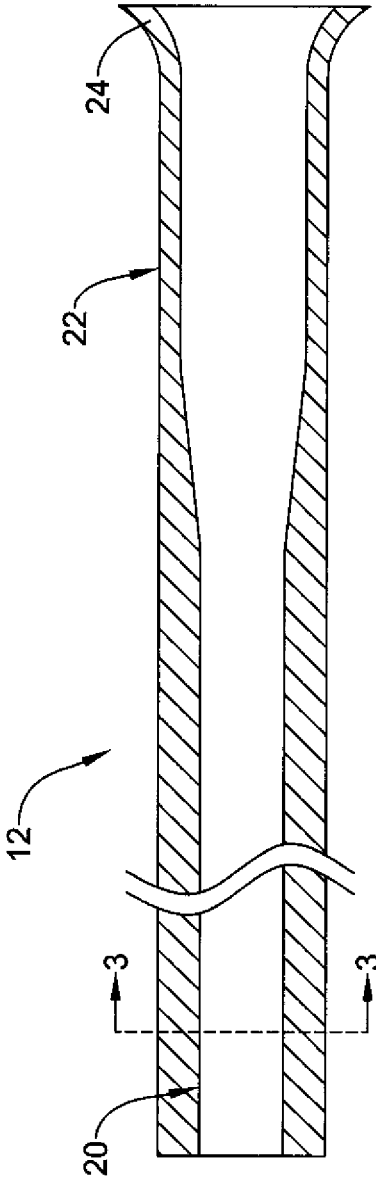

Figure 2

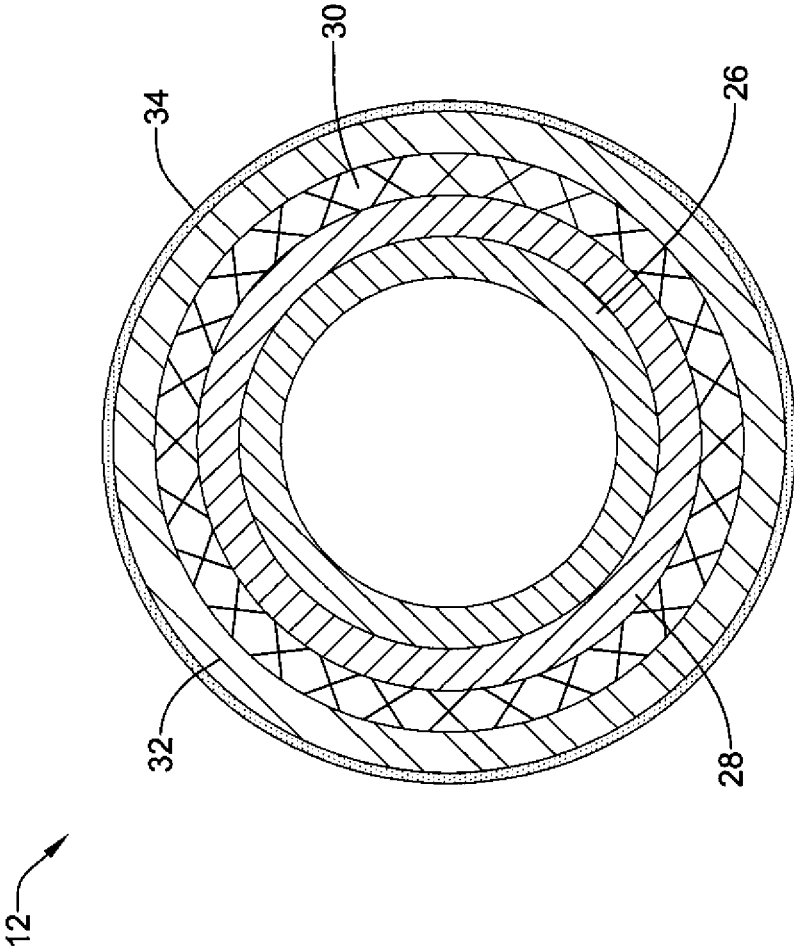

Figure 3

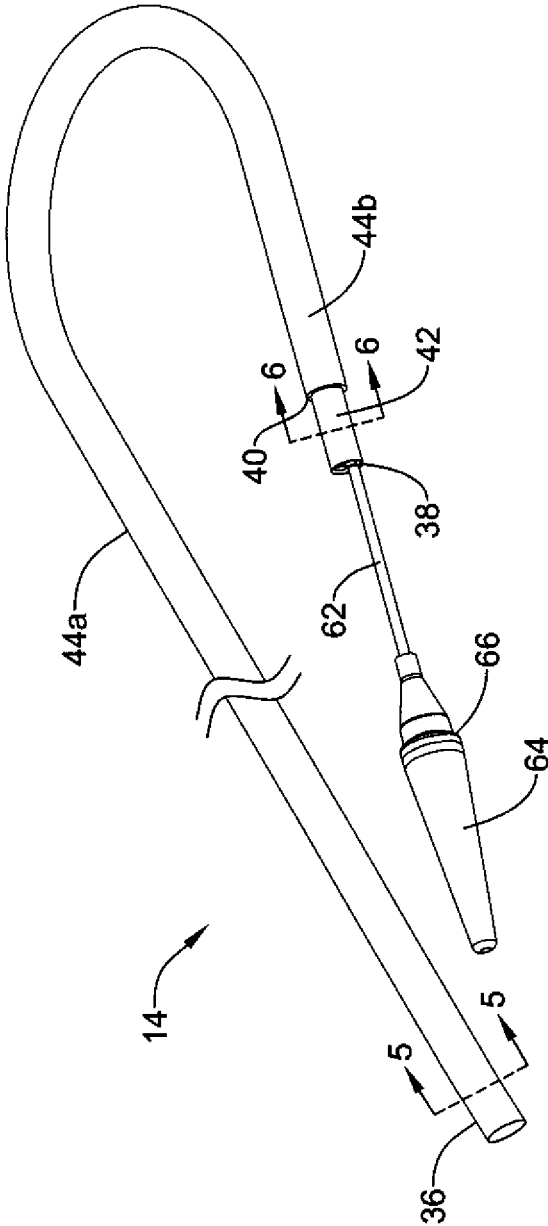

Figure 4

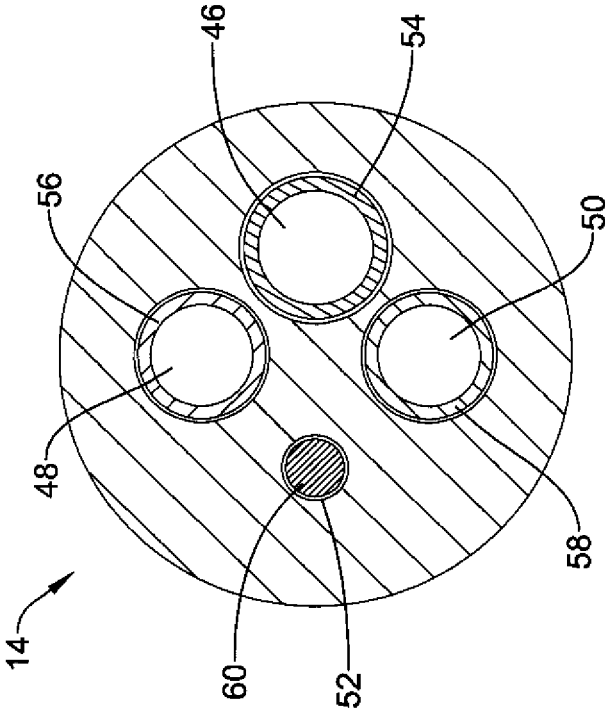

Figure 5

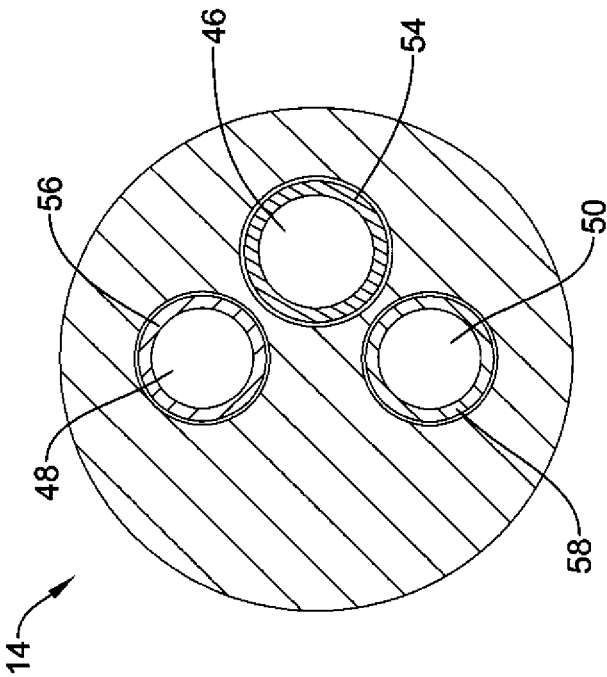

Figure 6

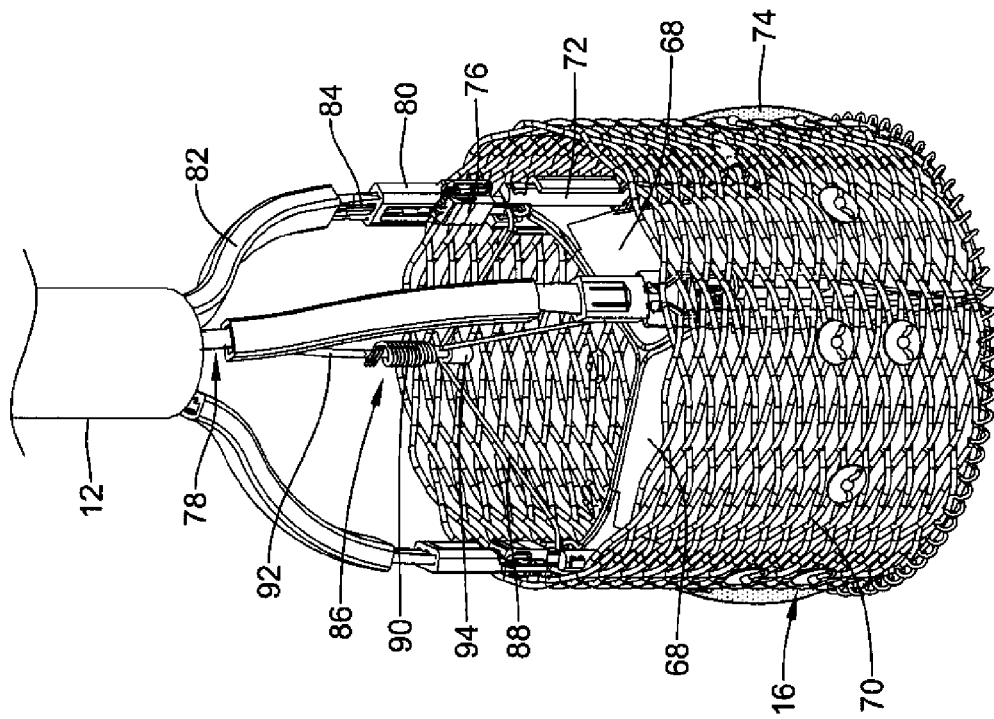

Figure 7

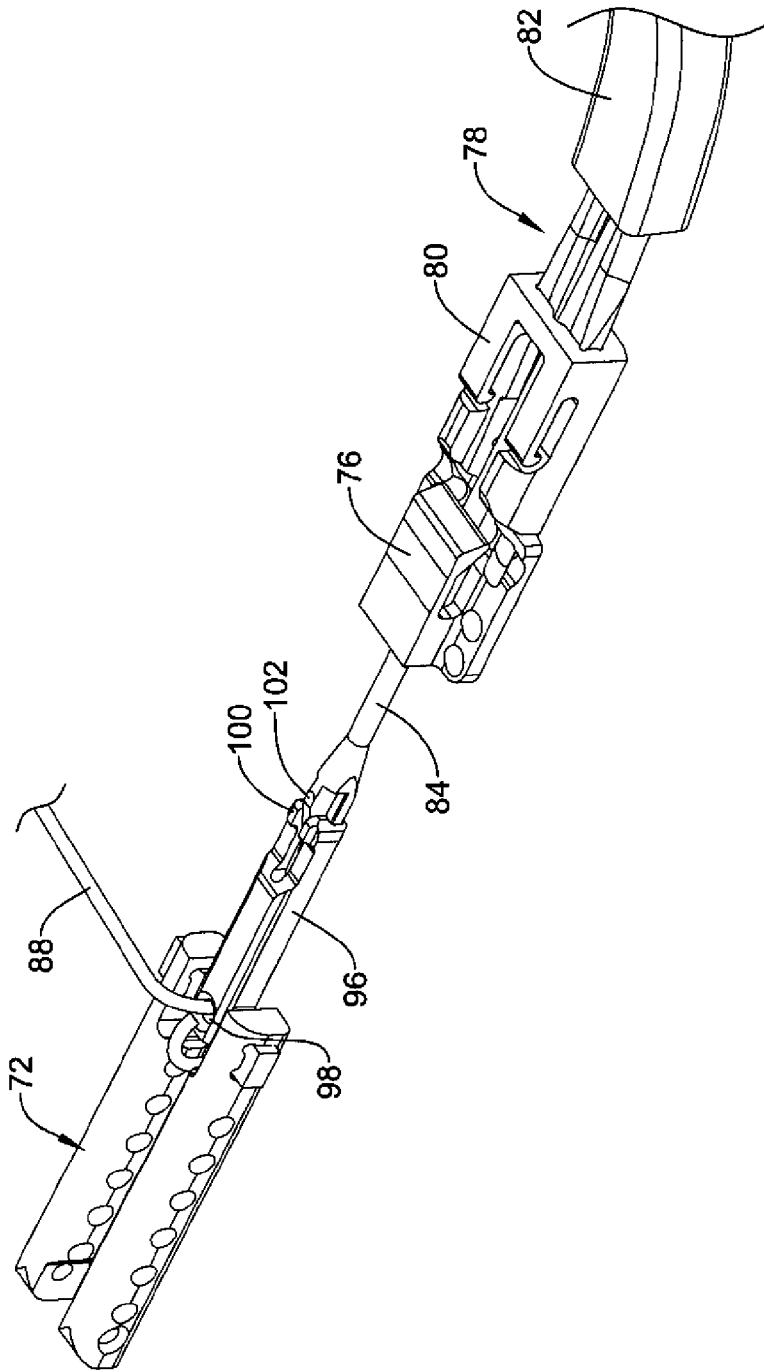

Figure 8

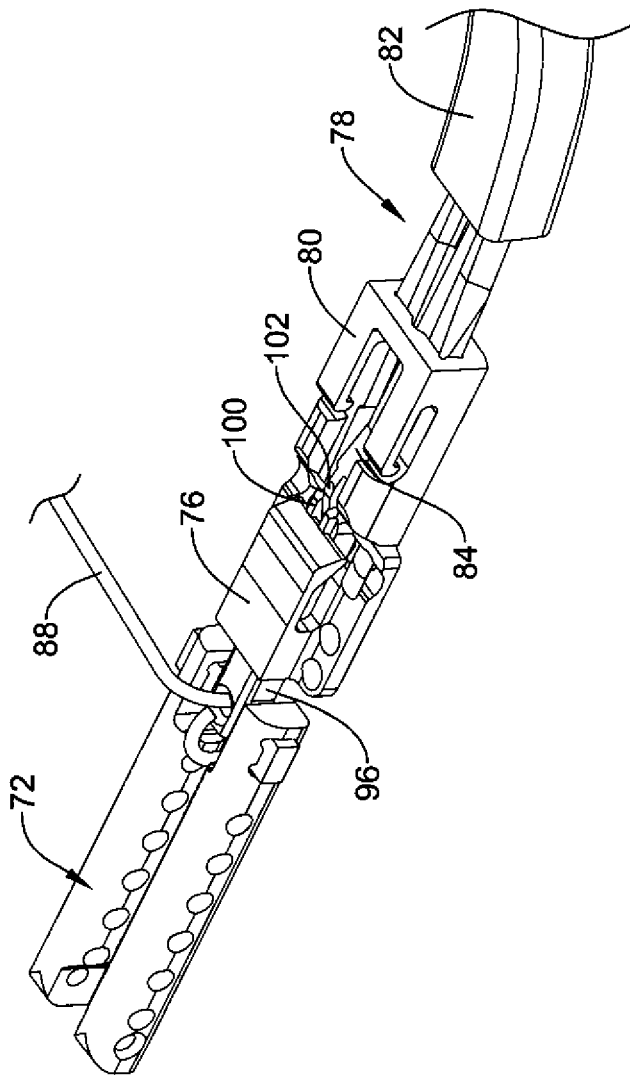

Figure 9

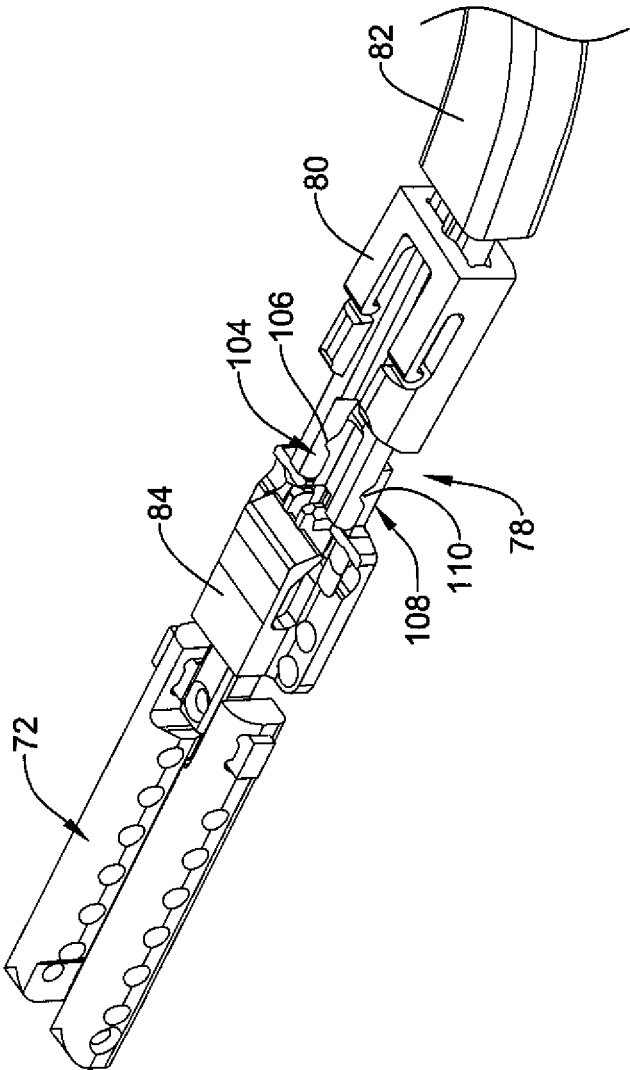

Figure 10

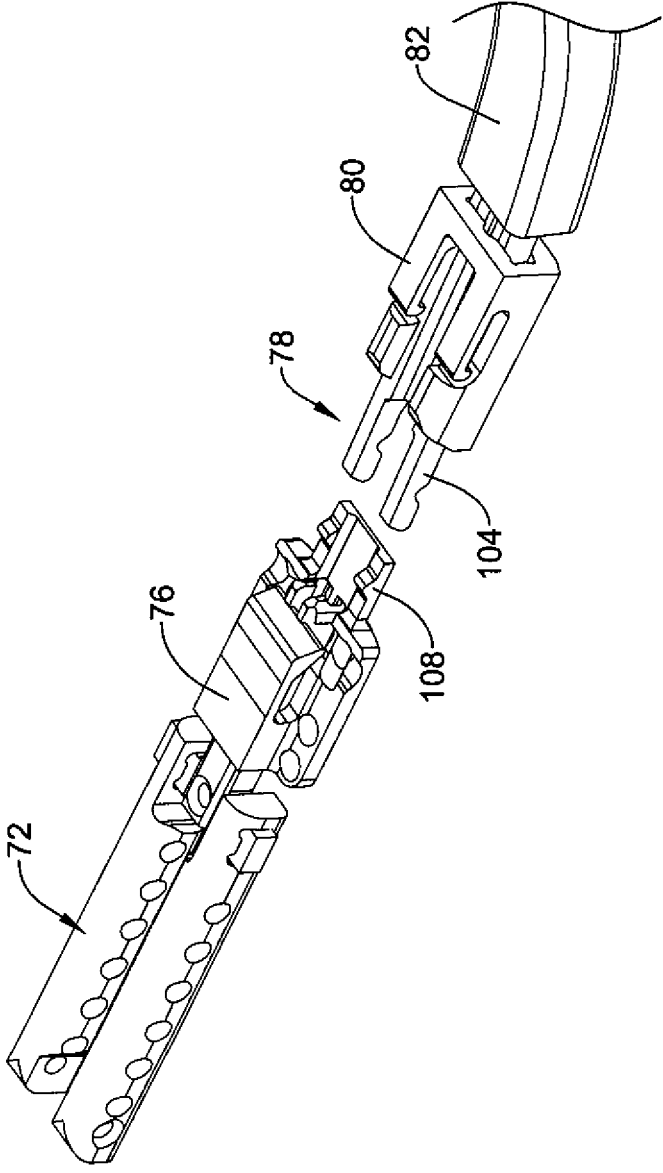

Figure 11

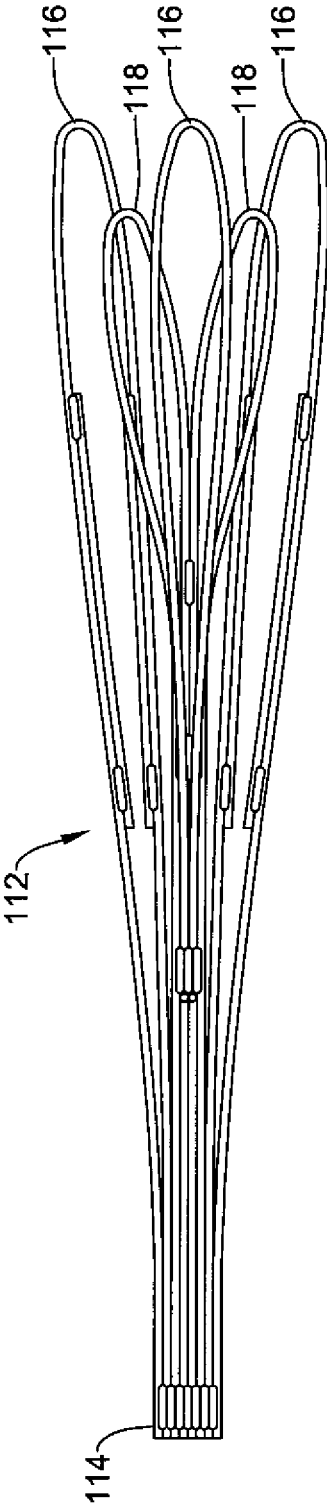

Figure 12

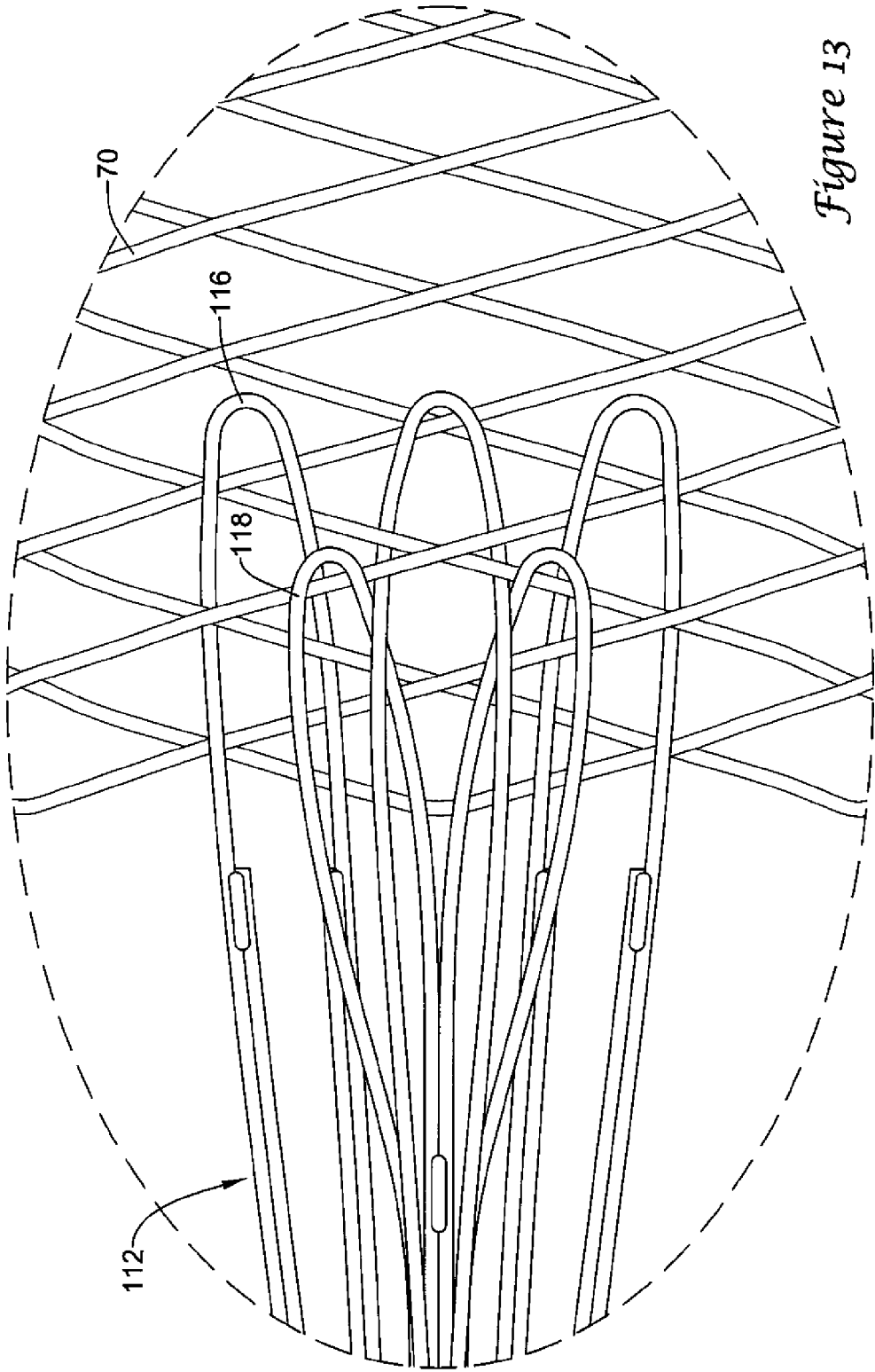

Figure 13

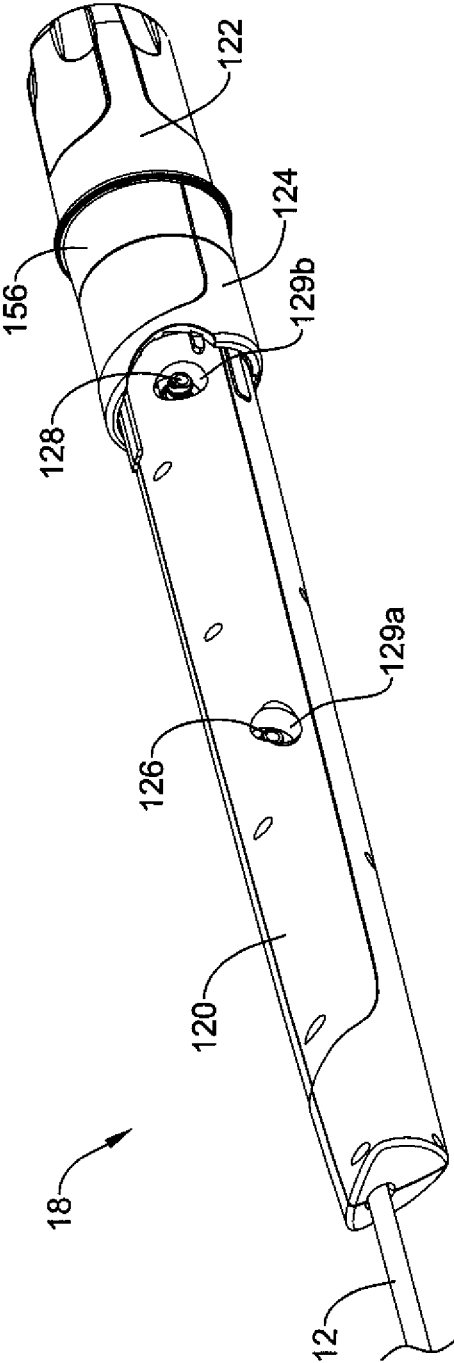

Figure 14

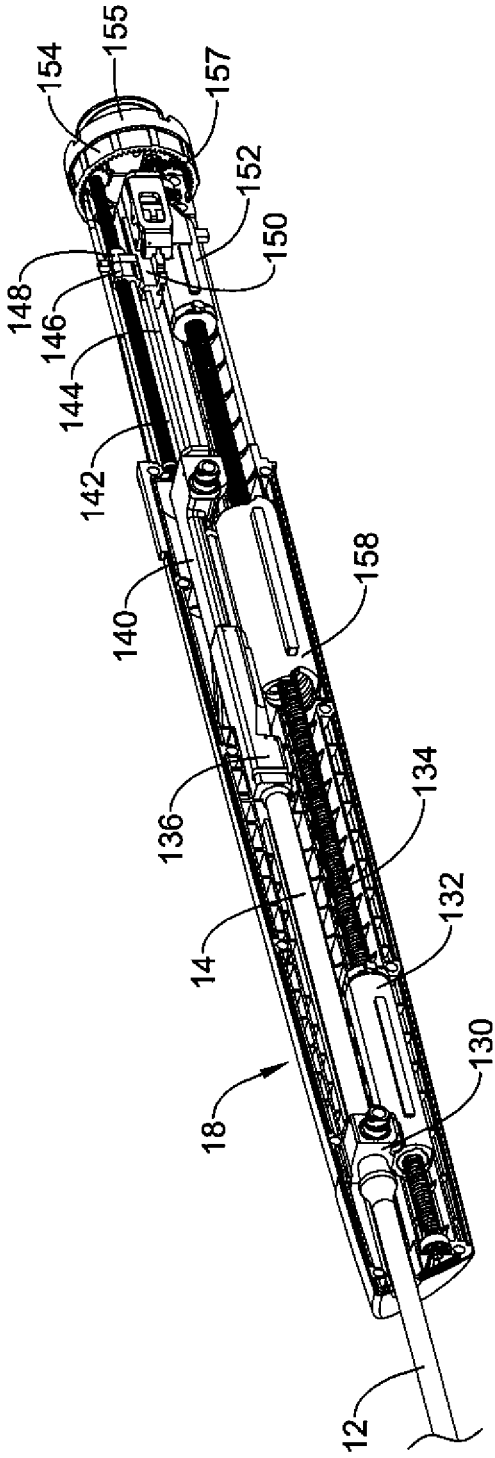

Figure 15

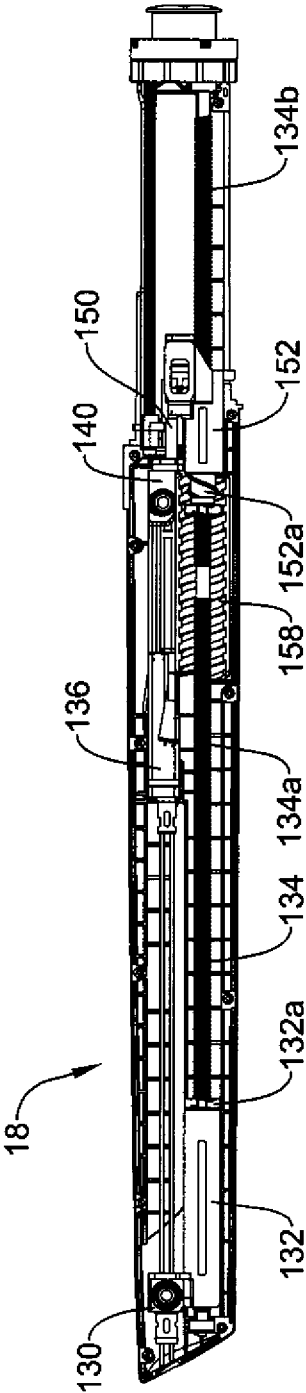

Figure 16

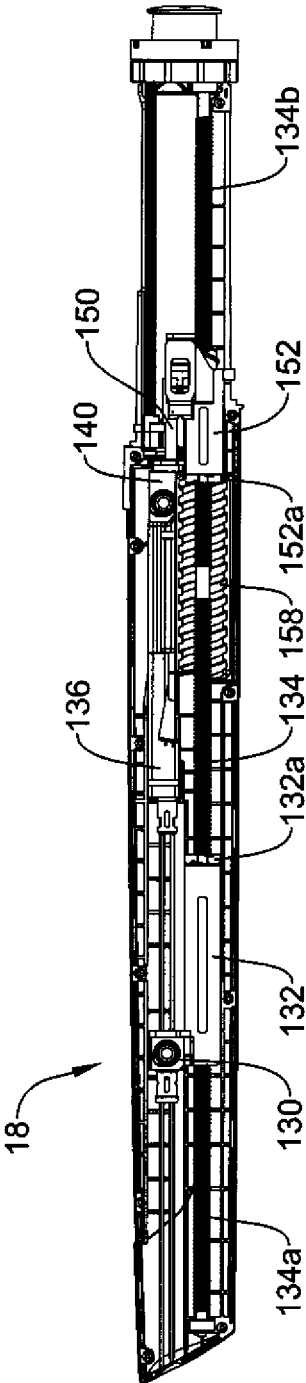

Figure 17

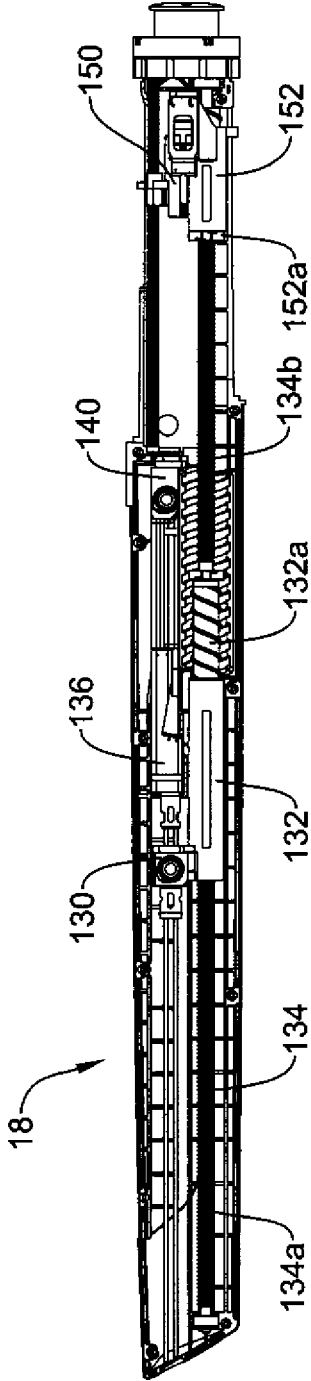

Figure 18

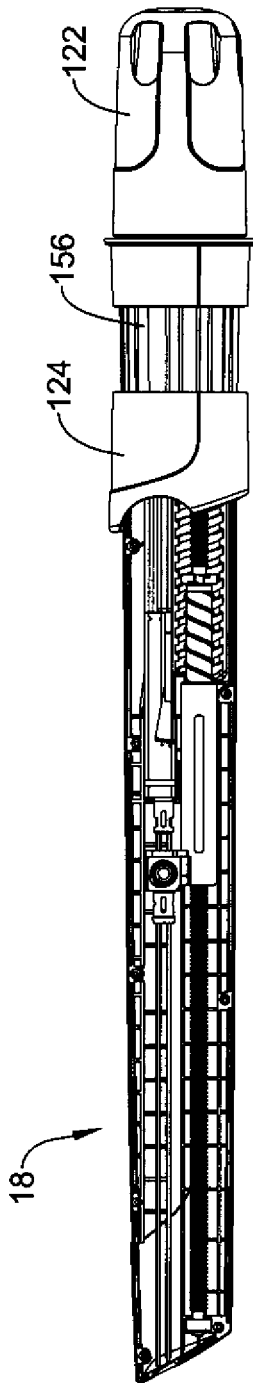

Figure 19

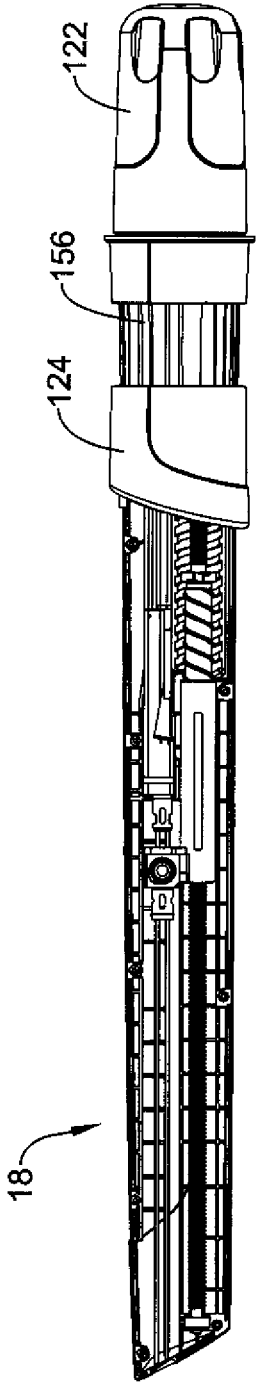

Figure 20

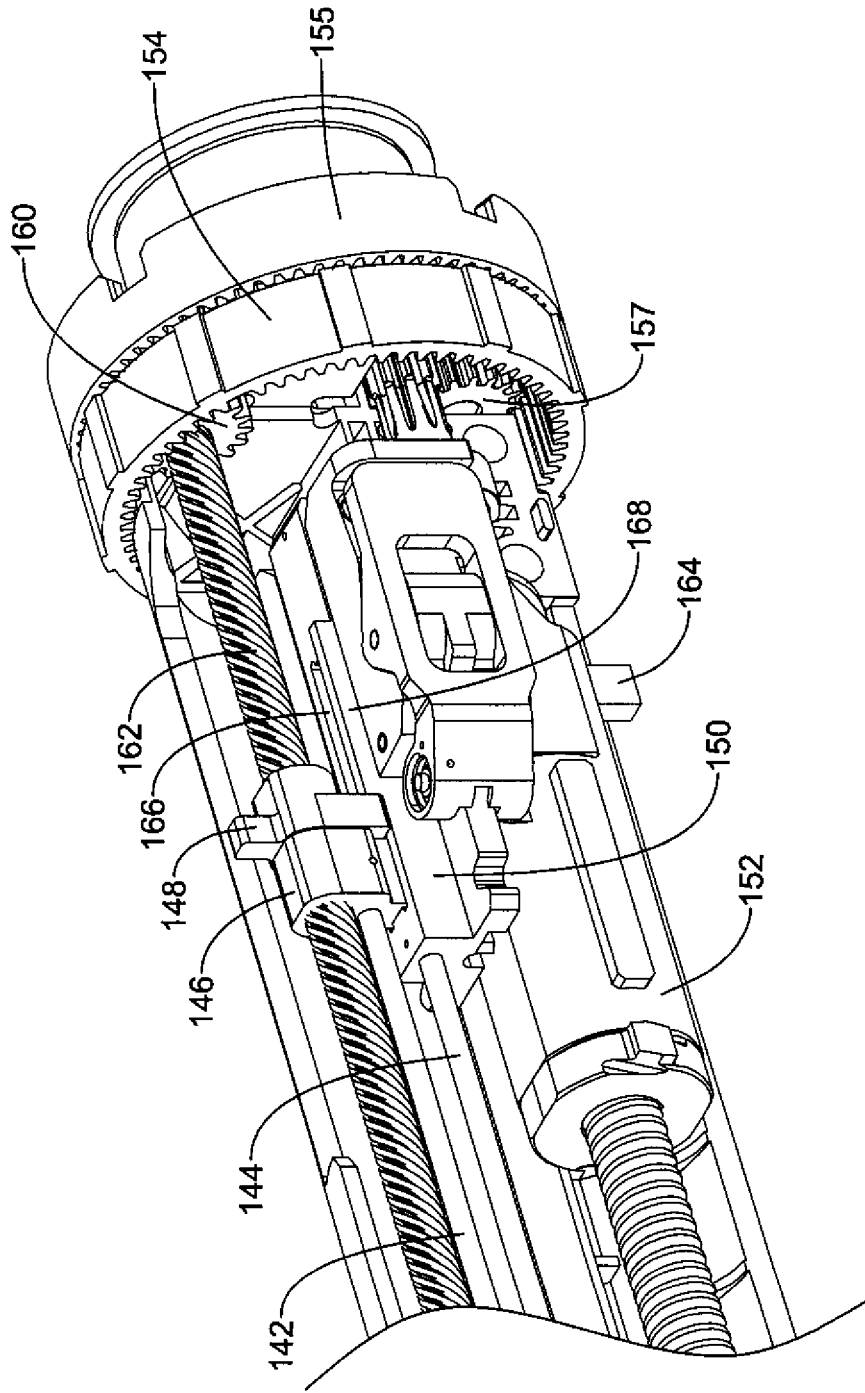

Figure 21

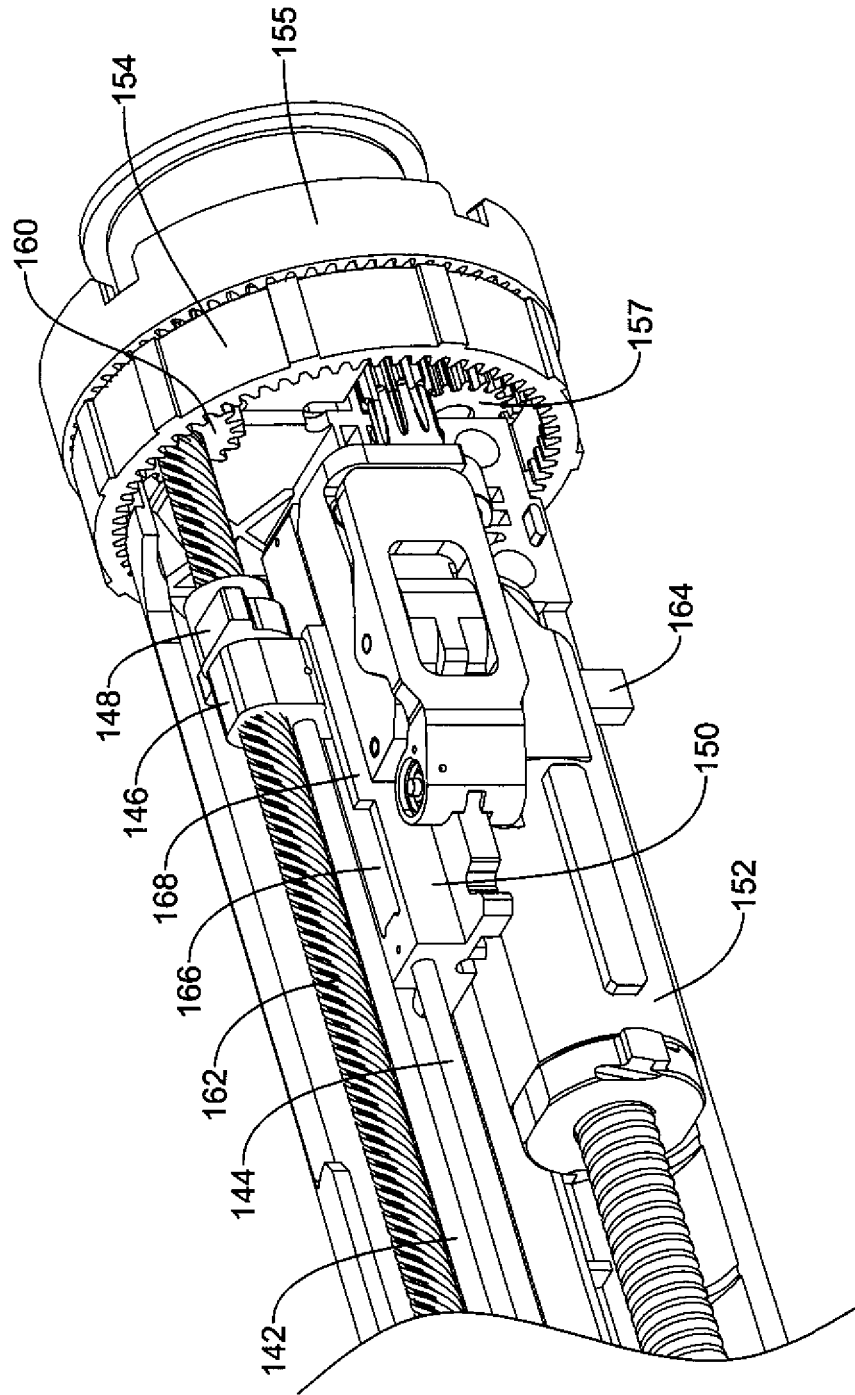

Figure 22

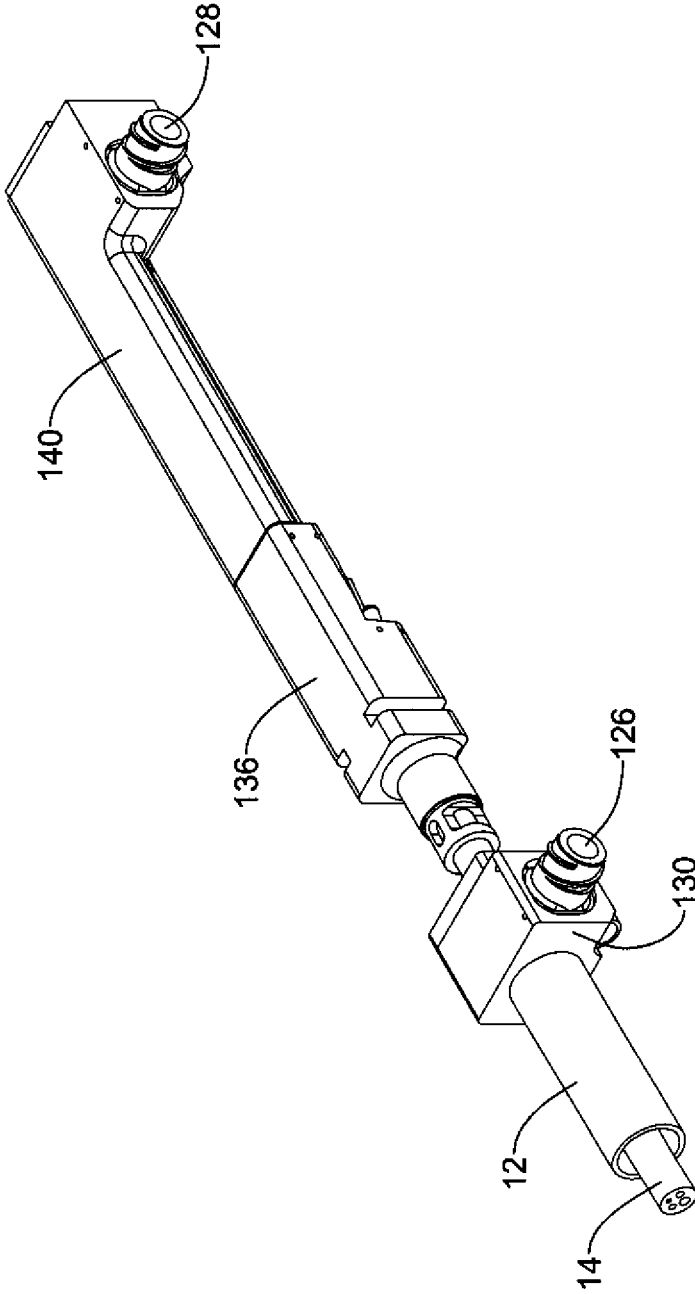

Figure 23

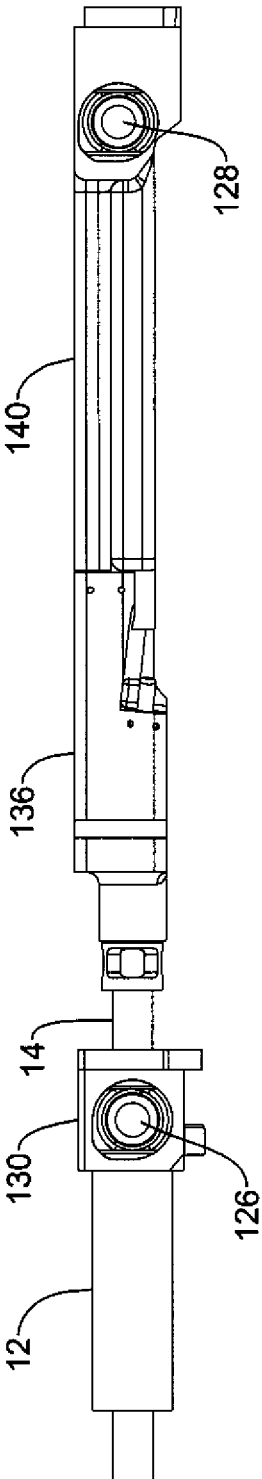

Figure 24

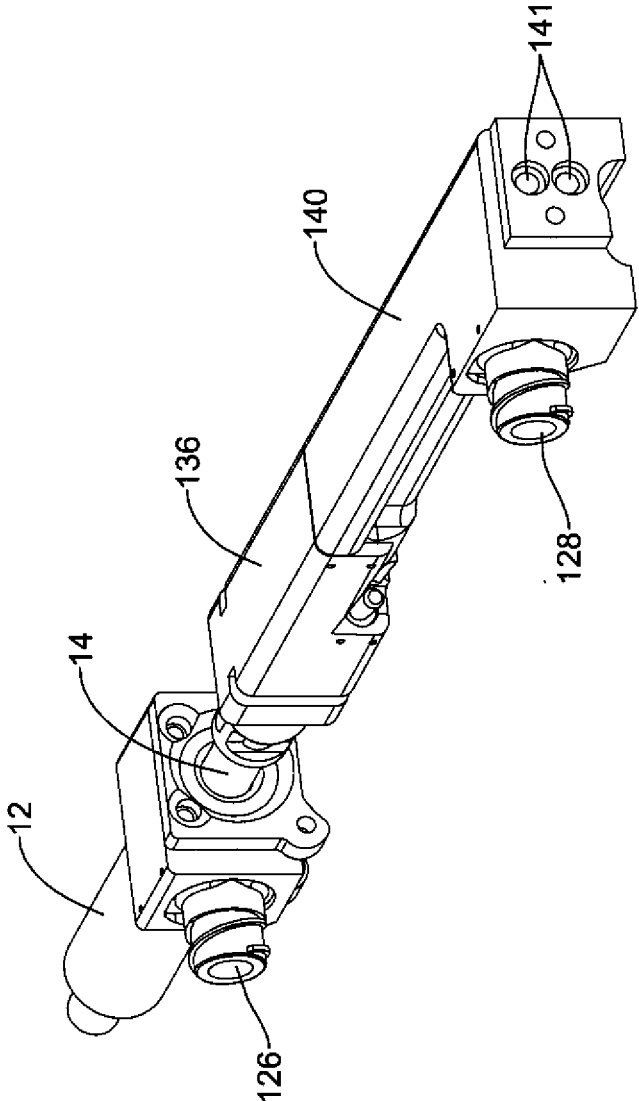

Figure 25

DIRECT CONNECT FLUSH SYSTEM

BACKGROUND

[0001] Medical devices typically used for cardiovascular system treatments may involve complex and invasive therapies resulting in significant discomfort, pain, and long recovery times for patients. Recently, less invasive, percutaneous treatments have been developed. There is an ongoing need for improved, less invasive cardiovascular treatments.

SUMMARY

[0002] A medical device may comprise a handle housing having an interior space therein, wherein the handle housing includes a side wall defining the interior space, a proximal aperture extending through the side wall to the interior space, and a distal aperture extending through the side wall to the interior space, an elongate outer sheath having a lumen therein extending distally from the distal end of the handle housing, an elongate inner member extending distally through the distal end of the handle housing within the lumen of the elongate outer sheath, a proximal flush port disposed within the interior space and in fluid communication with the elongate inner member, and a distal flush port disposed within the interior space and in fluid communication with the lumen of the elongate outer sheath.

[0003] A medical device may comprise a handle housing having an interior space therein, wherein the handle housing includes a side wall defining the interior space, a proximal aperture extending through the side wall to the interior space, and a distal aperture extending through the side wall to the interior space, an elongate outer sheath having a lumen therein extending distally from the distal end of the handle housing, an elongate inner member extending distally through the distal end of the handle housing within the lumen of the elongate outer sheath, a proximal flush port fixedly disposed within the interior space and in fluid communication with the elongate inner member, a distal flush port movably disposed within the interior space and in fluid communication with the lumen of the elongate outer sheath, and a control knob at the proximal end of the handle housing, wherein rotating the control knob relative to the handle housing moves the distal flush port longitudinally within the interior space.

[0004] A medical device may comprise a handle housing including a side wall having laterally-facing proximal and distal apertures extending therethrough, an elongate outer sheath having a lumen therein extending distally from the distal end of the handle housing, an elongate inner member extending distally through the distal end of the handle housing within the lumen of the elongate outer sheath, a laterally-facing proximal flush port fixedly disposed within the handle housing and in fluid communication with the elongate inner member, a laterally-facing distal flush port movably disposed within the handle housing and in fluid communication with the lumen of the elongate outer sheath, and a control knob disposed about the proximal end of the handle housing, wherein rotating the control knob about the handle housing moves the distal flush port relative to the handle housing in a direction parallel to the longitudinal axis.

BRIEF DESCRIPTION OF THE DRAWINGS

[0005] The invention may be more completely understood in consideration of the following detailed description of vari-

ous embodiments of the invention in connection with the accompanying drawings, in which:

[0006] FIG. 1 is side view of an example medical device system;

[0007] FIG. 2 is a cross-sectional side view of an example outer sheath;

[0008] FIG. 3 is a transverse cross-sectional view taken through line 3-3 in FIG. 2;

[0009] FIG. 4 is a side view of an example inner catheter;

[0010] FIG. 5 is a cross-sectional view taken through line 5-5 in FIG. 4;

[0011] FIG. 6 is a cross-sectional view taken through line 6-6 in FIG. 4;

[0012] FIG. 7 is a perspective view of a portion of an example implant associated with the example medical device system;

[0013] FIGS. 8-11 are perspective views that illustrate an example mechanism for locking an implant;

[0014] FIG. 12 is a side view of a portion of an example sheathing aid;

[0015] FIG. 13 is an enlarged plan view illustrating engagement of the example sheathing aid with an example implant;

[0016] FIG. 14 is a side view of an example handle;

[0017] FIG. 15 is a cut away view illustrating some of the interior components of the example handle;

[0018] FIGS. 16-18 illustrate an example of coordinated movement of handle components within the example handle;

[0019] FIGS. 19-20 illustrate the rotation of a collar on the example handle;

[0020] FIGS. 21-22 illustrate some of the components within the example handle during rotation of the collar; and

[0021] FIGS. 23-25 are partial perspective views schematically illustrating some of the components within the example handle.

[0022] While the invention is amenable to various modifications and alternative forms, specifics thereof have been shown by way of example in the drawings and will be described in detail. It should be understood, however, that the intention is not to limit the invention to the particular embodiments described. On the contrary, the intention is to cover all modifications, equivalents, and alternatives falling within the spirit and scope of the invention.

DETAILED DESCRIPTION

[0023] For the following defined terms, these definitions shall be applied, unless a different definition is given in the claims or elsewhere in this specification.

[0024] All numeric values are herein assumed to be modified by the term "about," whether or not explicitly indicated. The term "about" generally refers to a range of numbers that one of skill in the art would consider equivalent to the recited value (i.e., having the same function or result). In many instances, the term "about" may include numbers that are rounded to the nearest significant figure.

[0025] The recitation of numerical ranges by endpoints includes all numbers within that range (e.g. 1 to 5 includes 1, 1.5, 2, 2.75, 3, 3.80, 4, and 5).

[0026] As used in this specification and the appended claims, the singular forms "a," "an," and "the" include plural referents unless the content clearly dictates otherwise. As used in this specification and the appended claims, the term "or" is generally employed in its sense including "and/or" unless the content clearly dictates otherwise.

[0027] The following detailed description should be read with reference to the drawings in which similar elements in different drawings are numbered the same. The drawings, which are not necessarily to scale, depict illustrative embodiments and are not intended to limit the scope of the invention.

[0028] Diseases and/or medical conditions that impact the cardiovascular system are prevalent in the United States and throughout the world. Traditionally, treatment of the cardiovascular system was often conducted by directly accessing the impacted part of the system. For example, treatment of a blockage in one or more of the coronary arteries was traditionally treated using coronary artery bypass surgery. As can be readily appreciated, such therapies are rather invasive to the patient and require significant recovery times and/or treatments. More recently, less invasive therapies have been developed, for example, where a blocked coronary artery could be accessed and treated via a percutaneous catheter (e.g., angioplasty). Such therapies have gained wide acceptance among patients and clinicians.

[0029] Some relatively common medical conditions may include or be the result of inefficiency, ineffectiveness, or complete failure of one or more of the valves within the heart. For example, failure of the aortic valve can have a serious effect on a human and could lead to serious health condition and/or death if not dealt with. Treatment of defective heart valves poses other challenges in that the treatment often requires the repair or outright replacement of the defective valve. Such therapies may be highly invasive to the patient. Disclosed herein are medical devices that may be used for delivering a medical device to a portion of the cardiovascular system in order to diagnose, treat, and/or repair the system. At least some of the medical devices disclosed herein may be used to deliver and implant a replacement heart valve (e.g., a replacement aortic valve). In addition, the devices disclosed herein may deliver the replacement heart valve percutaneously and, thus, may be much less invasive to the patient. The devices disclosed herein may also provide a number of additional desirable features and benefits as described in more detail below.

[0030] FIG. 1 is a side view of an example medical device system 10. It should be noted that some features of system 10 are either not shown, or are shown schematically, in FIG. 1 for simplicity. Additional details regarding some of the components of system 10 are provided in other figures in greater detail. System 10 may be used to deliver and/or deploy a variety of medical devices to a number of locations within the anatomy. In at least some embodiments, system 10 is a replacement heart valve delivery system (e.g., a replacement aortic valve delivery system) that can be used for percutaneous delivery of a replacement heart valve. This, however, is not intended to be limiting as system 10 may also be used for other interventions including mitral valve replacement, valve repair, valvuloplasty, and the like, or other similar interventions.

[0031] System 10 may generally be described as a catheter system that includes an outer sheath or catheter 12 and an inner catheter or tube 14 (a portion of which is shown in FIG. 1 in phantom line) extending at least partially through outer sheath 12. A medical device implant 16 may be coupled to inner catheter 14 and disposed within outer sheath 12 during delivery of implant 16. A handle 18 may be disposed at the proximal end of outer sheath 12 and inner catheter 14. In general, handle 18 may be configured to manipulate the posi-

tion of outer sheath 12 relative to inner catheter 14 as well as aid in the deployment of implant 16.

[0032] In use, system 10 may be advanced percutaneously through the vasculature to a position adjacent to an area of interest. For example, system 10 may be advanced through the vasculature to a position adjacent to a defective aortic valve. During delivery, implant 16 may be generally disposed in an elongated and low profile “delivery” configuration within outer sheath 12. Once positioned, outer sheath 12 may be refracted to expose implant 16. Implant 16 may be actuated in order to expand implant into a generally shortened and larger profile “deployed” configuration suitable for implantation within the anatomy. When implant 16 is suitably deployed within the anatomy, system 10 can be removed from the vasculature, leaving implant 16 in place to function as, for example, a suitable replacement for the native aortic valve. In at least some interventions, implant 16 may be deployed within the native valve (e.g., the native valve is left in place and not excised). Alternatively, the native valve may be removed and implant 16 may be deployed in its place as a replacement.

[0033] FIGS. 2-13 (as well as other figures) illustrate some of the components of system 10. For example, FIG. 2 is a cross-sectional side view of outer sheath 12. Here it can be seen that outer sheath 12 has a proximal portion 20 and a distal portion 22. Distal portion 22 may have a slightly enlarged or flared inner diameter, which may provide additional space for holding implant 16 therein. For example, the inner diameter of outer sheath 12 along proximal portion 20 may be in the range of about 0.254 to 1.27 cm (0.10 to 0.50 inches), or about 0.508 to 1.016 cm (0.20 to 0.40 inches), or about 0.508 to 0.762 cm (0.20 to 0.30 inches), or about 0.56388±0.0508 cm (0.222±0.002 inches). The inner diameter of outer sheath 12 along distal portion 22 may be in the range of about 0.254 to 1.27 cm (0.10 to 0.50 inches), or about 0.508 to 1.016 cm (0.20 to 0.40 inches), or about 0.508 to 0.762 cm (0.20 to 0.30 inches), or about 0.579 to 0.5842 cm (0.228 to 0.230 inches). At the distal end of distal portion 22 may be a distal tip 24, which may be flared or otherwise have a funnel-like shape. The funnel-like shape increases the outer diameter (and inner diameter) of outer sheath 12 at distal tip 24 and may aid in the sheathing and/or re-sheathing of implant 16 into outer sheath 12. Other than at distal tip 24, outer sheath 12 may have a generally constant outer diameter. For example, outer sheath 12 may have an outer diameter in the range of about 0.254 to 1.27 cm (0.10 to 0.50 inches), or about 0.508 to 1.016 cm (0.20 to 0.40 inches), or about 0.508 to 0.762 cm (0.20 to 0.30 inches), or about 0.6858 cm (0.270 inches). These are just examples. Other embodiments are contemplated that have differing dimensions (including those appropriate for differently sized patients including children) and/or arrangements for the outer diameter and/or inner diameter of outer sheath 12. These contemplated embodiments include outer sheaths with flared or otherwise variable outer diameters, embodiments with constant inner diameters, combinations thereof, and the like. Outer sheath 12 may also have a length that is appropriate for reaching the intended area of interest within the anatomy. For example, outer sheath 12 may have a length in the range of about 30 to 200 cm, or about 60 to 150 cm, or about 100 to 120 cm, or about 108±0.20 cm. Outer sheath 12 may also be curved. For example, a distal section of outer sheath 12 may be curved. In one example, the radius of the curve (measured from the center of outer sheath 12) may be in the range of about 2 to 6 cm (20 to 60 mm), or

about 3 to 4 cm (30 to 40 mm), or about 3.675 cm (36.75 mm). Again, these dimensions are examples and are not intended to be limiting.

[0034] Outer sheath **12** may be formed from a singular monolithic tube or unitary member. Alternatively, outer sheath **12** may include a plurality of layers or portions. One or more of these layers may include a reinforcing structure such as a braid, coil, mesh, combinations thereof, or the like. FIG. 3 illustrates one example of a multilayer structure for outer sheath **12**. For example, outer sheath **12** may include an inner liner or layer **26**. An intermediate or tier layer **28** may be disposed on inner liner **26**. A reinforcement **30** may be disposed on intermediate layer **28**. A topcoat or outer layer **32** may be disposed on reinforcement **30**. Finally, an outer coating **34** (e.g., a lubricious coating, a hydrophilic coating, a hydrophobic coating, etc.) may be disposed along portions or all of topcoat **32**. These are just examples. Several alternative structural configurations are contemplated for outer sheath **12** including embodiments including two or more layers that may be different from those shown in FIG. 3, embodiments without a reinforcement, and the like, or other suitable configurations.

[0035] The dimensions and materials utilized for the various layers of outer sheath **12** may also vary. For example, inner liner **26** may include a polymeric material such as fluorinated ethylene propylene (FEP) and may have a thickness in the range of about 0.00254 to 0.0127 cm (0.001 to 0.005 inches) or about 0.00762±0.00254 (0.003±0.001 inches), intermediate layer **28** may include a polymer material such as polyether block amide (e.g., PEBAX 6333) and may have a thickness in the range of about 0.00254 to 0.0127 cm (0.001 to 0.005 inches) or about 0.00508±0.00254 (0.002±0.001 inches), outer coating **34** may include a polymer material such as polyether block amide (e.g., PEBAX 7233) and may have a thickness in the range of about 0.00254 to 0.0254 cm (0.001 to 0.01 inches). In some embodiments, outer coating **34** may vary in thickness. For example, along proximal portion **20** outer coating **34** may have greater thickness, such as about 0.0127 to about 0.0508 cm or about 0.02159 cm (0.005 to 0.02 inches or about 0.0085 inches), than along distal portion **22** and/or distal tip **24**, which may be about 0.0127 to about 0.0508 cm or about 0.01651 cm (e.g., about 0.005 to 0.02 inches or about 0.0065 inches). These are just examples as other suitable materials may be used.

[0036] The form of distal tip **24** may also vary. For example, in at least some embodiments, inner liner **26** (i.e., a 2.5 mm section thereof) may be extended up and around the distal end of outer sheath **12** (e.g., around reinforcement **30** and topcoat **32**). A ring member (not shown) made from a suitable material such as a 55D polyether block amide (e.g., 55D PEBAX) may be disposed over inner liner **26** and heat bonded to form distal tip **24**. This may form the funnel-like shape of distal tip **24**.

[0037] Reinforcement **30** may also vary in form. In at least some embodiments, reinforcement **30** may take the form of a braid, coil, mesh, or the like. For example, in some embodiments, reinforcement **30** may include a metallic braid (e.g., stainless steel). In some of these embodiments, reinforcement **30** may also include additional structures such as one or more longitudinally-extending strands. For example, reinforcement **30** may include a pair of longitudinally-extending aramid and/or para aramid strands (for example, KEVLAR®) disposed on opposite sides of the braid. These strands may or may not be woven into portions or all of the braid.

[0038] FIG. 4 is a side view of the inner catheter **14**. A distal end region of inner catheter **14** may include a step in outer diameter **40** that defines a decreased outer diameter section **42**. For example, decreased outer diameter section **42** may have an outer diameter in the range of about 0.127 to 0.635 cm (0.05 to 0.25 inches), or about 0.254 to 0.508 cm (0.10 to 0.20 inches), or about 0.38608±0.00762 (0.152±0.003 inches) as opposed to the remainder of inner catheter **14** where the outer diameter may be in the range of about 0.127 to 0.762 cm (0.05 to 0.30 inches), or about 0.254 to 0.635 cm (0.10 to 0.25 inches), or about 0.508±0.0254 cm (0.20±0.01 inches). Decreased outer diameter section **42** may define a region where other components of system **10** may be attached. Some additional details regarding these components can be found herein.

[0039] In general, inner catheter **14** may take the form of an extruded polymer tube. Other forms are also contemplated including other polymer tubes, metallic tubes, reinforced tubes, or the like including other suitable materials such as those disclosed herein. In some embodiments, inner catheter **14** is a singular monolithic or unitary member. In other embodiments, inner catheter **14** may include a plurality of portions or segments that are coupled together. The total length of inner catheter may be in the range of about 60 to 150 cm, or about 80 to 120 cm, or about 100 to 115 cm, or about 112±0.02 cm. Just like outer sheath **12**, inner catheter **14** may also be curved, for example adjacent to the distal end thereof. In some embodiments, inner catheter **14** may have one or more sections with a differing hardness/stiffness (e.g., differing shore durometer). For example, inner catheter may have a proximal region **44a** and an intermediate region **44b**. Proximal region **44a** may include a generally stiff polymeric material such as a 72D polyether block amide (e.g., 72D PEBAX) and may have a length in the range of about 60 to 150 cm, or about 80 to 120 cm, or about 100 to 115 cm, or about 109.5±0.02 cm. Intermediate region **44b** may include a 40D polyether block amide (e.g., 40D PEBAX) and may have a length in the range of about 5 to 25 mm, or about 10 to 20 mm, or about 15±0.01 mm. Decreased outer diameter section **42** may also differ from regions **44a/44b** and, in some embodiments, may include a 72D polyether block amide (e.g., 72D PEBAX) and may have a length in the range of about 0.5 to 2 cm (5 to 20 mm), or about 0.8 to 1.5 cm (8 to 15 mm), or about 1±0.001 cm (10±0.01 mm). These are just examples.

[0040] Inner catheter **14** may include one or more lumens. For example, FIG. 5 (which is a cross-sectional view of inner catheter **14** adjacent to proximal end portion **36**) illustrates that inner catheter **14** may include a first lumen **46**, a second lumen **48**, a third lumen **50**, and a fourth lumen **52**. In general, lumens **46/48/50/52** extend along the entire length of inner catheter **14**. Other embodiments are contemplated, however, where one or more of lumens **46/48/50/52** extend along only a portion of the length of inner catheter **14**. For example, fourth lumen **52** may stop just short of the distal end of inner catheter **14** and/or be filled in at its distal end to effectively end fourth lumen **52** proximal of the distal end of inner catheter **14**, as illustrated in FIG. 6 by the absence of fourth lumen **52** adjacent to the distal end of inner catheter **14**.

[0041] Disposed within first lumen **46** may be push-pull rods **84** (not shown in FIG. 5, seen in other figures including FIG. 7), which are used to expand and/or elongate implant **16** as explained in more detail herein. In at least some embodiments, first lumen **46** may be lined with a low friction liner **54** (e.g., a FEP liner). Disposed within second lumen **48** may be

a pin release mandrel **92** (not shown in FIG. 5, seen in other figures including FIG. 7), which is also explained in more detail herein. In at least some embodiments, second lumen **48** may be lined with a hypotube liner **56**. Third lumen **50** may be a guidewire lumen and this lumen may also be lined with a hypotube liner **58**.

[0042] Fourth lumen **52** may be used to house a non-stretch wire **60**. The form of non-stretch wire **60** may vary. In some embodiments, non-stretch wire **60** may take the form of a stainless steel braid. The non-stretch wire **60** may optionally include a pair of longitudinally-extending aramid and/or para aramid strands (for example, KEVLAR®) disposed on opposite sides of the braid. In general, rather than being “disposed within” fourth lumen **52**, non-stretch wire **60** may be embedded within fourth lumen **52**. In addition, non-stretch wire **60** may extend to a position adjacent to distal end portion **38** but not fully to the distal end of inner catheter **14** as illustrated in FIG. 6 by the absence of fourth lumen **52** adjacent to the distal end of inner catheter **14**. For example, a short distal segment of fourth lumen **52** may be filled in with polymer material adjacent to the distal end of inner catheter **14**.

[0043] Inner catheter **14** may also include a guidewire extension tube **62** that extends distally from distal end portion **38**. A nose cone **64** is attached to guidewire extension tube **62**. Nose cone **64** generally is designed to have an atraumatic shape. Nose cone **64** may also include a ridge or ledge **66** that is configured to abut the distal tip **24** of outer sheath **12** during delivery of implant **16**.

[0044] FIG. 7 illustrates some of the additional components of system **10** and implant **16**. For example, here it can be seen that implant **16** includes a plurality of valve leaflets **68** (e.g., bovine pericardial) which are secured to a cylindrical braid **70** at a post or commissure post **72**, for example at the commissure portions of the leaflets **68**. In this example, implant **16** includes three leaflets **68** secured to braid **70** with three posts **72**. Leaflets **68** may also be secured to the base or “distal end” of braid **70**. The posts **72**, in turn, may be secured to braid **70** (e.g., along the interior of braid **70**) with sutures or other suitable mechanisms. Positioned adjacent to (e.g., longitudinally spaced from and aligned with) posts **72** are a plurality of buckles **76**, which may also be sutured to braid **70** (e.g., along the interior of braid **70**). In this example, one buckle **76** is attached to braid **70** adjacent to each of the three posts **72**. Accordingly, braid **70** has a total of three buckles **76** and three posts **72** attached thereto. Other embodiments are contemplated where fewer or more buckles **76** and posts **72** may be utilized. A seal **74** (shown in cross-section) may be disposed about braid **70** and, as the name suggests, may help to seal implant **16** within a target implant site or area of interest.

[0045] Attachment between implant **16** and inner catheter **14** (and/or outer sheath **12**) may be effected through the use of a three finger coupler **78**. Coupler **78** may generally include a cylindrical base (not shown) that is attached to inner catheter **14** (e.g., disposed about and attached to reduced outer diameter section **42**). Projecting distally from the base are three fingers that are each configured to engage with implant **16** at posts **72** and buckles **76**. A collar **80** may further assist in holding together these structures. A guide **82** may be disposed over each of the fingers and may serve to keep the fingers of coupler **78** associated with push-pull rods **84** extending adjacent to coupler **78**. Finally, a pin release assembly **86** may be a linking structure that keeps posts **72**, buckles **76**, and push-pull rods **84** associated with one another. Pin release assembly **86** includes a plurality of individual pins **88** that may be

joined together via a coiled connection **90** and held to a pin release mandrel **92** with a ferrule **94**.

[0046] During delivery, implant **16** is secured at the distal end of inner catheter **14** by virtue of the association of the fingers of coupler **78** being coupled with a projecting proximal end of buckles **76** (and being held in place with collar **80** disposed over the connection) and by virtue of pins **88** securing together push-pull rods **84** and posts **72**. When implant **16** is advanced within the anatomy to the desired location, outer sheath **12** may be withdrawn (e.g., moved proximally relative to inner catheter **14**) to expose implant **16**. Then, push-pull rods **84** can be used to expand and “lock” implant **16** in the expanded or deployed configuration by proximally retracting push-pull rods **84** to pull posts **72** into engagement with buckles **76**. Finally, pins **88** can be removed, thereby uncoupling push-pull rods **84** from posts **72**, which allows implant **16** to be released from system **10** and deployed in the anatomy.

[0047] FIGS. 8-11 illustrate the locking system utilized with system **10**. For simplicity purposes, only one of the three fingers of the coupler **78**, only one of the three push-pull rods **84**, and only one of the posts **72** of the example system **10** are shown (and implant **16** is not shown). As seen in FIG. 8, push-pull rod **84** extends through guide **82** adjacent to the fingers of coupler **78**, through collar **80**, through buckle **76**, and into a hollow t-shaped bar portion **96** of post **72**. The distal end of push-pull rod **84** may include an opening or aperture (not shown) that can be aligned with an opening **98** of t-shaped bar portion **96**. When so aligned, pin **88** can be looped through opening **98** and the opening of push-pull rod **84**. This secures push-pull rod **84** to post **72** and forms a configuration of these structures that can be utilized during delivery of implant **16**. As can be appreciated, the proximal end of post **72** and the distal end of buckle **76** are longitudinally separated and, accordingly, implant **16** is in an elongated and generally low-profile configuration suitable for delivery.

[0048] When implant **16** reaches the intended target site within the anatomy, a clinician can proximally retract push-pull rod **84**, thereby moving the proximal ends of posts **72** toward the distal ends of buckles **76** in order to expand implant **16**. Ultimately, push-pull rod **84** can be retracted sufficiently far enough to lock post **72** with buckle **76** so as to lock implant in an expanded configuration suitable for implantation within the anatomy. FIG. 9 illustrates push-pull rod **84** proximally retracted. In doing so, post **72** is brought into contact with buckle **76**. More particularly, a raised, generally transversely-oriented ridge **100** on t-shaped bar portion **96** may be pulled proximally past buckle **76** so that post **72** is secured and held in place by buckle **76**. At this point, it is possible to urge push-pull rods **84** distally to “unlock” implant **16**, thereby allowing for repositioning and/or retraction. Alternatively, if a clinician is satisfied with the positioning and/or locking of implant **16** (e.g., after visualization of implant **16** via a suitable imaging technique), pins **88** may be pulled (e.g., removed from openings **98** and the openings in push-pull rods **84**) to uncouple push-pull rods **84** from posts **72** as shown in FIG. 10. Further retraction of push-pull rods **84** causes a longitudinally-oriented ridge **102** on push-pull rods **84** to engage collar **80** and causes collar **80** to slide proximally along the fingers of coupler **78**. In doing so, a forked end **104** of the fingers, which has a groove **106** formed therein, is exposed and can be uncoupled from a rail **108**, which has a projection **110** formed thereon that is configured

to mate with groove 106, as shown in FIG. 11. Thereafter, system 10 can be removed from the anatomy, leaving behind the expanded and deployed implant 16.

[0049] FIGS. 12-13 illustrate another component that may be included with system 10. For example, FIG. 12 is a side view of a portion of a sheathing aid 112. Here it can be seen that sheathing aid 112 includes a base 114 and a group of petals including a set of three longer petals 116 and a pair of shorter petals 118. In use, a group of petals 116/118 may be positioned between each of the fingers of coupler 78. Because the coupler 78 may have a total of three fingers, sheathing aid 112 may have a total of fifteen petals (e.g., three groups that each include three “long” petals 116 and two “short” petals 118, with each group being positioned between adjacent pairs of fingers of coupler 78). Base 114 may be secured to inner catheter 14 adjacent to coupler 78 (e.g., underneath coupler 78 and between coupler 78 and inner catheter 14).

[0050] Sheathing aid 112, as the name suggests, may be used to aid in the sheathing of implant 16 into outer sheath 12. In addition, sheathing aid 112 may aid in the initial sheathing of implant 16 (e.g., removing implant 16 from a packaging container such as a bottle and pulling implant 16 into outer sheath 12) and in re-sheathing implant 16 during repositioning and/or retraction of implant 16 within the area of interest. Sheathing may be accomplished via the arrangement and positioning of the various petals 116/118. For example, FIG. 13 illustrates the longer petals 116 woven in and out of braid 70, and the shorter petals 118 disposed along the exterior of braid 70 acting as a funnel for sheathing.

[0051] FIG. 14 is a side view of handle 18. Here it can be seen that handle 18 includes a handle housing 120. A rotatable control knob 122 may be disposed about handle housing 120 (e.g., at a proximal end of handle housing 120) and may be used to move one or more of the components of system 10 (e.g., outer sheath 12, push-pull rods 84, etc.). A rotatable collar 156 may be disposed about the handle housing 120. In some embodiments, control knob 122 may be disposed about a proximal portion of collar 156. A slidable door 124 may also be disposed about handle housing 120. Door 124 may translate distally to expose a distal portion of rotatable collar 156 (not shown in FIG. 14, can be seen in other figures including FIGS. 19-20) positioned generally under door 124. Collar 156 may be rotated to move one or more components of system 10 (e.g., push-pull rods 84, pin release mandrel 92, etc.). Handle 18 may also include one or more apertures 129a/129b and/or flush ports 126/128 that can be used to flush system 10. In some embodiments, distal flush port 126 and proximal flush port 128 are disposed within the handle housing 120 and may generally face laterally relative to a longitudinal axis of the handle housing 120 so as to be accessible from the exterior of the handle housing 120 through distal aperture 129a and proximal aperture 129b, respectively. Some components of system 10 related to the flush ports 126/128 may be seen in greater detail in FIGS. 23-25.

[0052] FIG. 15 is a side view of handle 18 with a portion of handle housing 120 removed, exposing at least some of the interior components. It should be noted that some components within handle 18 are not shown in FIGS. 15-20 for clarity. In FIG. 15, it can be seen that handle housing 120 includes a side wall defining an interior space of the handle housing 120. In some embodiments, the side wall substantially surrounds the interior space. In some embodiments, outer sheath 12 and inner catheter 14 may extend through a distal end of the handle housing 120. In some embodiments,

the proximal flush port 128 and the distal flush port 126 may be disposed within the interior space. Outer sheath 12 may be attached (e.g., fixedly attached) to an axially movable sheath adapter 130, as seen in FIGS. 15 and 23-25. Sheath adapter 130 is attached to a sheath carriage 132, which may be threaded onto a lead screw 134. Sheath carriage 132 may move axially within the handle housing 120 in response to rotation of the control knob 122. Distal flush port 126 may be disposed on sheath adapter 130. As such, distal flush port 126 may be axially and/or longitudinally movable within the interior space of the handle housing 120 when the control knob 122 is rotated. In general, distal flush port 126 is in fluid communication with the interior or lumen of outer sheath 12, so as to provide access to the interior or lumen of outer sheath 12 (e.g., access to space between inner catheter 14 and outer sheath 12) so that a clinician can flush fluid through the lumen of outer sheath 12 to remove any unwanted materials (e.g., air, fluid, contaminants, etc.) therein prior to use of system 10.

[0053] In at least some embodiments, distal flush port 126 has a luer type connector (e.g., a one-way luer connector) that allows a flushing device such as a syringe with a corresponding connector to be attached thereto for flushing. In some embodiments, the flushing device (e.g., a syringe) can be directly connected to the distal flush port 126 through distal aperture 129a. That is, a flushing device may be connected to the distal flush port 126 without the aid or presence of other intervening elements or structure such as tubing or adapters, and the like. A direct connection may reduce opportunity for leaks or interference of connecting elements with other components within handle 18 during operation, as well as streamline overall assembly of the medical device system 10.

[0054] Inner catheter 14 may extend through and proximally from sheath adapter 130. A proximal end of inner catheter 14 is attached (e.g., fixedly attached) to an interior body or diverter 136. A proximal end of diverter 136 is attached (e.g., fixedly attached) to a distal end of a support body 140. The diverter 136 and support body 140 may be fixed in position relative to the handle housing 120. Accordingly, inner catheter 14 may be fixed in position relative to the handle housing 120.

[0055] In general, diverter 136 and/or support body 140 may have one or more passageways or lumens formed therein. In some embodiments, push-pull rods 84 and/or pin release mandrel 92 may extend through respective passageways. Alternatively, the proximal ends of push-pull rods 84 and/or pin release mandrel 92 may each be attached to a shaft or hypotube (e.g., solid in cross-section, tubular, etc.), and each of the shafts may extend through the one or more passageways. For example, a first shaft or hypotube 142 and a second shaft or hypotube 144 may extend through the passageways in diverter 136 and/or support body 140, and in some embodiments, the first shaft or hypotube 142 extends through a first passageway and the second shaft or hypotube 144 extends through a second passageway that is separate or distinct from the first passageway. In at least some embodiments, first shaft 142 is attached (e.g., fixedly attached) to pin release mandrel 92. In at least some embodiments, second shaft 144 is attached (e.g., fixedly attached) to push-pull rods 84. It should be noted that at least some embodiments of system 10, three push-pull rods 84 are utilized. In these embodiments, the three push-pull rods 84 come together (e.g., brought into contact with one another or otherwise brought into relatively close proximity with one another) adjacent to the distal end of inner catheter 14 and enter first

lumen 46. At one or more positions along their length, push-pull rods 84 may be attached to one another. For example, in some embodiments, push-pull rods 84 may be welded together about 10.16 cm (about 4.00 inches) from their distal ends. In some embodiments, push-pull rods 84 may be welded together proximate their proximal ends in addition to or instead of the distal weld. Proximally thereafter, push-pull rods 84 may extend to second shaft 144.

[0056] A hypotube (e.g., hypotube liner 58 disposed along guidewire lumen 52) may extend through diverter 136 within a passageway therein and then be “diverted” around a portion of diverter 136 and support body 140, and ultimately be extended to a position at the proximal end of handle 18 so as to provide a user access to guidewire lumen 52. In some embodiments, support body 140 may have a plurality of lumens 141 (e.g. two, or more, lumens) extending longitudinally therethrough, as shown in FIG. 25. Proximal flush port 128 may be disposed on or attached (e.g., fixedly attached) to the support body 140, and may be in fluid communication with the inner catheter 14. In some embodiments, the proximal flush port 128 may be in fluid communication with the lumens 141 of support body 140. In some embodiments, the lumens 141 of support body 140 are fluidly connected to diverter 136 and/or inner catheter 14. Proximal flush port 128 may be used to flush the lumens 141 of inner catheter 14 and, for example, may function similarly to distal flush port 126 described above.

[0057] In some embodiments, fluid introduced into the proximal flush port 128 may pass through the inner catheter 14 and discharge from a distal end thereof. Fluid introduced into the distal flush port 126 may similarly pass through the lumen of outer sheath 12 (e.g., within the space between the inner catheter 14 and the outer sheath 12) and discharge from a distal end thereof. In general, fluid introduced into one of the outer sheath 12 and the inner catheter 14 does not enter an interior or lumen of the other (e.g., fluid introduced into the inner catheter 14 does not enter the lumen of outer sheath 12) upon discharge from the respective distal end.

[0058] Proximal flush port 128 may be attached to support body 140, and distal flush port may be attached to sheath adapter 130 using one or more of a number of various fastening or attachment means. For example, flush ports 126/128 may be held within the sheath adapter 130 and/or support body 140 by pins extending across a flange formed on the flush ports 126/128. In some embodiments, flush ports 126/128 may be threaded and screwed into place within the sheath adapter 130 and/or support body 140. In some embodiments, flush ports 126/128 may be attached to sheath adapter 130 and/or support body 140 via a snap-fit, press-fit, or interference fit. In some embodiments, an adhesive may be added to seal the connections against leaks. In some embodiments, an O-ring or other compression seal may be utilized between adjoining components.

[0059] At their respective proximal ends, first shaft 142 may be secured to a slider 146 and second shaft 144 may be secured to a force limiter body 150. The connections between the various components may include a number of different types of connections including mechanical bonding (e.g., pinning, threading, interference fit, etc.), adhesive bonding, thermal bonding, etc. Slider 146 may be slidable relative to force limiter body 150. In some embodiments, slider 146 may be selectively locked to force limiter body 150, thereby preventing relative movement between the slider 146 and the force limiter body 150. Force limiter body 150 may be

secured to a push-pull rod carriage 152, which may be threaded onto lead screw 134. Thus, movement of lead screw 134 can cause movement of push-pull rod carriage 152 and force limiter body 150 and thus, push-pull rods 84 (via second shaft 144). Some additional details regarding this motion can be found herein.

[0060] In general, force limiter body 150 forms or defines a stop point that provides tactile feedback (e.g., resistance to further rotation of control knob 122) to the user indicating that push-pull rods 84 have been retracted proximally a sufficient distance to lock posts 72 with buckles 76. To verify proper locking, a clinician may use an appropriate visualization technique to visualize proper locking (e.g., the relative positioning of the posts 72 and the buckles 76). A chock 148 may be positioned adjacent to slider 146 to selectively lock slider 146 to force limiter body 150. In order to allow pin release mandrel 92 to be proximally retracted to pull pins 88, chock 148 can be rotated or otherwise moved to a secondary position or configuration. When in this configuration, chock 148 no longer forms a barrier to further movement of, for example, slider 146 and pin release mandrel 92. Accordingly, with chock 148 no longer acting as an impediment, slider 146 and pin release mandrel 92 can be proximally retracted to facilitate deployment of implant 16 by allowing pins 88 to be pulled.

[0061] Handle 18 also includes a rotatable ring 155 with internal teeth that are configured to engage with teeth on a gear 157 coupled to lead screw 134. Ring 155 is coupled to control knob 122 so that rotation of control knob 122 results in analogous motion of ring 155 and thus lead screw 134.

[0062] Handle 18 is generally configured for coordinated movement of multiple structures of system 10. For example, handle 18 is configured to allow a user to move outer sheath 12 (e.g., relative to inner catheter 14), move push-pull rods 84, and move pin release mandrel 92. Moreover, handle 18 is configured so that the appropriate structure can be moved at the appropriate time during the intervention so that implant 16 can be delivered in an efficient manner. Some examples of how the coordinated movement of system 10 may occur within handle 18 may be similar to those disclosed in U.S. Patent Application Pub. No. US 2010/0280495, the entire disclosure of which is herein incorporated by reference.

[0063] To help facilitate the coordinated movement, handle 18 may include a lost motion barrel 158. Lost motion barrel 158 is configured to engage carriages 132/152 and/or screws associated with carriages 132/152 at different times during the intervention to stop motion (e.g., create “lost motion” of the appropriate carriage). FIGS. 16-19 illustrate some of the coordinated motion achieved by handle 18. It should be noted that some elements of system 10 are not shown in FIGS. 16-20 for clarity. For example, FIG. 16 illustrates a first position or state for handle 18 where outer sheath 12 is extended distally relative to inner catheter 14 (and handle 18) so as to fully sheath (e.g., contain) implant 16. While in this position, sheath carriage 132 is positioned adjacent to the distal end of handle 18. In addition, a rod screw 152a associated with push-pull rod carriage 152 is extended distally from push-pull rod carriage 152 and positioned within lost motion barrel 158. Upon rotation of control knob 122 (e.g., in the clockwise direction), lead screw 134 begins to rotate. Rotation of lead screw 134 causes sheath carriage 132 to move along lead screw 134 in the proximal direction, resulting in proximal movement of outer sheath 12 (e.g., “unsheathing” implant 16). This initial rotation of lead screw 134 also causes

rod screw **152a** to rotate. This may be because, for example, a knob or projection (not shown) on rod screw **152a** may be engaged with a helical thread disposed along the interior of lost motion barrel **158**. However, because rod screw **152a** is spaced from push-pull rod carriage **152**, it does not exert a force onto push-pull rod carriage **152**. Thus, initial motion of control knob **122** does not result in movement of push-pull rod carriage **152** and, instead, only results in translation of sheath carriage **132** and rotation (and translation) of rod screw **152a**.

[0064] Eventually, rod screw **152a** (e.g., the knob formed therein) reaches an essentially linear thread or pathway formed at the end of lost motion barrel **158**. The linear thread allows rod screw **152a** to translate along lead screw **134** to a position where rod screw **152a** contacts (e.g., is threaded within and abuts) push-pull rod carriage **152**. In doing so, rod screw **152a** can contact and move proximally push-pull carriage **152**. Accordingly, further rotation of lead screw **134** not only causes sheath carriage **132** to move proximally but also causes push-pull rod carriage **152** to move proximally as shown in FIG. 17.

[0065] When sheath carriage **132** reaches lost motion barrel **158**, a sheath carriage screw **132a** of sheath carriage **132** enters lost motion barrel **158** as shown in FIG. 18. This may occur in a manner similar to how rod screw **152a** threads and unthreads with the helical thread formed along lost motion barrel **158**. For example, while sheath carriage **132** is translating, sheath carriage screw **132a** may follow an essentially linear thread or pathway formed along or adjacent to lost motion barrel **158**. Upon reaching lost motion barrel **158**, sheath carriage screw **132a** (e.g., a knob or projection formed thereon) may shift into engagement with the helical thread within lost motion barrel **158** and rotate. This rotation “unthreads” sheath carriage screw **132a** from sheath carriage **132**. Accordingly, additional rotation of lead screw **134** results in continued proximal movement of push-pull rod carriage **152** while motion of sheath carriage **132** ceases.

[0066] In at least some embodiments, lead screw **134** has a plurality of portions, for example a first portion **134a** and a second portion **134b**, with a differing pitch to its thread. This may allow carriages **132/152** to travel at different rates along lead screw **134**. For example, the pitch of lead screw **134** along which sheath carriage **132** translates may be generally more spaced or slanted than at positions adjacent to push-pull rod carriage **152**. Accordingly, the coordinated movement of carriages **132/152** also may be configured so that sheath carriage **132** translates along lead screw **134** at a greater rate than push-pull rod carriage **152**. Other configurations are contemplated where the above-mentioned configuration is reversed as well as further configurations where the pitch of lead screw **134** is essentially constant or includes a number of different pitch regions.

[0067] Sufficient proximal retraction of push-pull rod carriage **152**, for example as shown in FIG. 18, may result in push-pull rods **84** being sufficiently retracted so that posts **72** can engage and lock with buckles **76**. When the clinician is satisfied that locking is complete (e.g., after verification via an appropriate visualization technique), the clinician may proximally retract pin release mandrel **92** in order to pull pins **88** from openings **98** and openings in push-pull rods **84** to release implant **16**.

[0068] To initiate release of pins **88**, door **124** may be slid distally along a collar **156** (which is positioned on handle **18**) as shown in FIG. 19. When door **124** is sufficiently advanced,

door **124** and collar **156**, together, can be rotated as shown in FIG. 20. Push-pull rod carriage **152** may also include a radially-extending proximal flag member **164**. In general, flag member **164** may be designed as a feature that can prevent collar **156** from being rotated earlier than desired (and, thus, prevent pins **88** from being pulled earlier than desired). For example, flag member **164** may be positioned within and follow a groove (not shown) along the interior of collar **156**. While positioned within the groove, flag member **164** essentially forms a physical barrier that prevents collar **156** from rotating relative to handle housing **120**. When push-pull rod carriage **152** is translated proximally to the back of handle housing **120** (e.g., when push-pull rods **84** are proximally retracted so as to lock posts **72** with buckles **76**), flag member **164** exits the groove in collar **156**. Accordingly, flag member **164** no longer impedes rotation of collar **156** and, as such, collar **156** can now be rotated to pull pins **88**.

[0069] Collar **156**, via ring **154**, is associated with a gear **160** engaged with a secondary screw **162**. Notches at a proximal end of collar **156** engage protrusions on ring **154** such that rotation of collar **156** causes corresponding rotation of ring **154** and thus secondary screw **162**. The initial rotation of collar **156** is sufficient to rotate chock **148** (e.g., via a mechanical interaction between collar **156** and chock **148** that causes chock **148** to shift) from a first configuration where slider **146** (and, thus, pin release mandrel **92**) is selectively locked to force limiter body **150**, to a secondary configuration, which permits slider **146** to translate along secondary screw **162** as secondary screw **162** rotates, to proximally retract and pull pins **88** (e.g., via pin release mandrel **92**). As seen in FIG. 21, chock **148** in the first configuration engages a ridge **168** along a top portion of force limiter body **150** which forms a physical barrier that prevents proximal translation of slider **146** relative to force limiter body **150**. When collar **156** is rotated to shift chock **148** into the secondary configuration, slider **146** can translate proximally within a groove **166** disposed in the top portion of force limiter body **150** (e.g., as seen in FIG. 22), as collar **156** is rotated about the handle housing **120** to pull the pins **88** from the openings **98** and the openings in the distal ends of the push-pull rods **84**. Once pins **88** have been removed, push-pull rods **84** may be withdrawn from implant **16**, thereby deploying the implant at the target site (area of interest).

[0070] Following deployment of the implant **16**, the control knob **122** may be rotated to move the sheath carriage **132** distally within the handle housing **120**, thereby moving outer sheath **12** distally relative to inner catheter **14** and three-finger coupler **78** so as to cover or re-sheath the elements of system **10** disposed at the distal end. System **10** may then be removed from the patient’s anatomy.

[0071] The materials that can be used for the various components of system **10** (and/or other systems disclosed herein) and the various tubular members disclosed herein may include those commonly associated with medical devices. For simplicity purposes, the following discussion makes reference to outer sheath **12** and/or inner catheter **14**. However, this is not intended to limit the devices and methods described herein, as the discussion may be applied to other similar tubular members and/or components of tubular members or devices disclosed herein.

[0072] Outer sheath **12** and/or inner catheter **14** may be made from a metal, metal alloy, polymer (some examples of which are disclosed below), a metal-polymer composite, ceramics, combinations thereof, and the like, or other suitable

material. Some examples of suitable metals and metal alloys include stainless steel, such as 304V, 304L, and 316LV stainless steel; mild steel; nickel-titanium alloy such as linear-elastic and/or super-elastic nitinol; other nickel alloys such as nickel-chromium-molybdenum alloys (e.g., UNS: N06625 such as INCONEL® 625, UNS: N06022 such as HASTELLOY® C-22®, UNS: N10276 such as HASTELLOY® C276®, other HASTELLOY® alloys, and the like), nickel-copper alloys (e.g., UNS: N04400 such as MONEL® 400, NICKELVAC® 400, NICORROS® 400, and the like), nickel-cobalt-chromium-molybdenum alloys (e.g., UNS: R30035 such as MP35-N® and the like), nickel-molybdenum alloys (e.g., UNS: N10665 such as HASTELLOY® ALLOY B2®), other nickel-chromium alloys, other nickel-molybdenum alloys, other nickel-cobalt alloys, other nickel-iron alloys, other nickel-copper alloys, other nickel-tungsten or tungsten alloys, and the like; cobalt-chromium alloys; cobalt-chromium-molybdenum alloys (e.g., UNS: R30003 such as ELGILOY®, PHYNOX®, and the like); platinum enriched stainless steel; titanium; combinations thereof; and the like; or any other suitable material.

[0073] As alluded to herein, within the family of commercially available nickel-titanium or nitinol alloys, is a category designated “linear elastic” or “non-super-elastic” which, although may be similar in chemistry to conventional shape memory and super elastic varieties, may exhibit distinct and useful mechanical properties. Linear elastic and/or non-super-elastic nitinol may be distinguished from super elastic nitinol in that the linear elastic and/or non-super-elastic nitinol does not display a substantial “superelastic plateau” or “flag region” in its stress/strain curve like super elastic nitinol does. Instead, in the linear elastic and/or non-super-elastic nitinol, as recoverable strain increases, the stress continues to increase in a substantially linear, or a somewhat, but not necessarily entirely linear relationship until plastic deformation begins or at least in a relationship that is more linear than the super elastic plateau and/or flag region that may be seen with super elastic nitinol. Thus, for the purposes of this disclosure linear elastic and/or non-super-elastic nitinol may also be termed “substantially” linear elastic and/or non-super-elastic nitinol.

[0074] In some cases, linear elastic and/or non-super-elastic nitinol may also be distinguishable from super elastic nitinol in that linear elastic and/or non-super-elastic nitinol may accept up to about 2-5% strain while remaining substantially elastic (e.g., before plastically deforming) whereas super elastic nitinol may accept up to about 8% strain before plastically deforming. Both of these materials can be distinguished from other linear elastic materials such as stainless steel (that can also be distinguished based on its composition), which may accept only about 0.2 to 0.44 percent strain before plastically deforming.

[0075] In some embodiments, the linear elastic and/or non-super-elastic nickel-titanium alloy is an alloy that does not show any martensite/austenite phase changes that are detectable by differential scanning calorimetry (DSC) and dynamic metal thermal analysis (DMTA) analysis over a large temperature range. For example, in some embodiments, there may be no martensite/austenite phase changes detectable by DSC and DMTA analysis in the range of about -60 degrees Celsius (° C.) to about 120° C. in the linear elastic and/or non-super-elastic nickel-titanium alloy. The mechanical bending properties of such material may therefore be generally inert to the effect of temperature over this very broad

range of temperature. In some embodiments, the mechanical bending properties of the linear elastic and/or non-super-elastic nickel-titanium alloy at ambient or room temperature are substantially the same as the mechanical properties at body temperature, for example, in that they do not display a super-elastic plateau and/or flag region. In other words, across a broad temperature range, the linear elastic and/or non-super-elastic nickel-titanium alloy maintains its linear elastic and/or non-super-elastic characteristics and/or properties.

[0076] In some embodiments, the linear elastic and/or non-super-elastic nickel-titanium alloy may be in the range of about 50 to about 60 weight percent nickel, with the remainder being essentially titanium. In some embodiments, the composition is in the range of about 54 to about 57 weight percent nickel. One example of a suitable nickel-titanium alloy is FHP-NT alloy commercially available from Furukawa Techno Material Co. of Kanagawa, Japan. Some examples of nickel titanium alloys are disclosed in U.S. Pat. Nos. 5,238,004 and 6,508,803, which are incorporated herein by reference. Other suitable materials may include ULTANIUM™ (available from Neo-Metrics) and GUM METAL™ (available from Toyota). In some other embodiments, a super-elastic alloy, for example a superelastic nitinol can be used to achieve desired properties.

[0077] In at least some embodiments, portions or all of outer sheath **12** and inner catheter **14** may also be doped with, made of, or otherwise include a radiopaque material. Radiopaque materials are understood to be materials capable of producing a relatively bright image on a fluoroscopy screen or another imaging technique during a medical procedure. This relatively bright image aids the user of system **10** in determining its location. Some examples of radiopaque materials can include, but are not limited to, gold, platinum, palladium, tantalum, tungsten alloy, polymer material loaded with a radiopaque filler, and the like. Additionally, other radiopaque marker bands and/or coils may also be incorporated into the design of system **10** to achieve the same result.

[0078] In some embodiments, a degree of Magnetic Resonance Imaging (MRI) compatibility is imparted into system **10**. For example, outer sheath **12** and inner catheter **14**, or portions thereof, may be made of a material that does not substantially distort the image and create substantial artifacts (i.e., gaps in the image). Certain ferromagnetic materials, for example, may not be suitable because they may create artifacts in an MRI image. Outer sheath **12** and inner catheter **14**, or portions thereof, may also be made from a material that the MRI machine can image. Some materials that exhibit these characteristics include, for example, tungsten, cobalt-chromium-molybdenum alloys (e.g., UNS: R30003 such as ELGILOY®, PHYNOX®, and the like), nickel-cobalt-chromium-molybdenum alloys (e.g., UNS: R30035 such as MP35-N® and the like), nitinol, and the like, and others.

[0079] A sheath or covering (not shown) may be disposed over portions or all of outer sheath **12** and inner catheter **14** that may define a generally smooth outer surface for system **10**. In other embodiments, however, such a sheath or covering may be absent from a portion of all of system **10**, such that outer sheath **12** and inner catheter **14** may form an outer surface. The sheath may be made from a polymer or other suitable material. Some examples of suitable polymers may include polytetrafluoroethylene (PTFE), ethylene tetrafluoroethylene (ETFE), fluorinated ethylene propylene (FEP), polyoxymethylene (POM, for example, DELRIN® available

from DuPont), polyether block ester, polyurethane (for example, Polyurethane 85A), polypropylene (PP), polyvinylchloride (PVC), polyether-ester (for example, ARNITEL® available from DSM Engineering Plastics), ether or ester based copolymers (for example, butylene/poly(alkylene ether) phthalate and/or other polyester elastomers such as HYTREL® available from DuPont), polyamide (for example, DURETHAN® available from Bayer or CRISTAMID® available from Elf Atochem), elastomeric polyamides, block polyamide/ethers, polyether block amide (PEBA, for example available under the trade name PEBAX®), ethylene vinyl acetate copolymers (EVA), silicones, polyethylene (PE), Marlex high-density polyethylene, Marlex low-density polyethylene, linear low density polyethylene (for example REXELL®), polyester, polybutylene terephthalate (PBT), polyethylene terephthalate (PET), polytrimethylene terephthalate, polyethylene naphthalate (PEN), polyetheretherketone (PEEK), polyimide (PI), polyetherimide (PEI), polyphenylene sulfide (PPS), polyphenylene oxide (PPO), polyparaphenylene terephthalamide (for example, KEVLAR®), polysulfone, nylon, nylon-12 (such as GRILAMID® available from EMS American Grilon), perfluoro(propyl vinyl ether) (PFA), ethylene vinyl alcohol, polyolefin, polystyrene, epoxy, polyvinylidene chloride (PVdC), poly(styrene-bisobutylene-b-styrene) (for example, SIBS and/or SIBS 50A), polycarbonates, ionomers, biocompatible polymers, other suitable materials, or mixtures, combinations, copolymers thereof, polymer/metal composites, and the like. In some embodiments the sheath can be blended with a liquid crystal polymer (LCP). For example, the mixture can contain up to about 6 percent LCP.

[0080] In some embodiments, the exterior surface of the system **10** (including, for example, the exterior surface of outer sheath **12** and inner catheter **14**) may be sandblasted, beadblasted, sodium bicarbonate-blasted, electropolished, etc. In these as well as in some other embodiments, a coating, for example a lubricious, a hydrophilic, a protective, or other type of coating may be applied over portions or all of the sheath, or in embodiments without a sheath over portion of outer sheath **12** and inner catheter **14**, or other portions of system **10**. Alternatively, the sheath may comprise a lubricious, hydrophilic, protective, or other type of coating. Hydrophobic coatings such as fluoropolymers provide a dry lubricity which improves device handling and device exchanges. Lubricious coatings improve steerability and improve lesion crossing capability. Suitable lubricious polymers are well known in the art and may include silicone and the like, hydrophilic polymers such as high-density polyethylene (HDPE), polytetrafluoroethylene (PTFE), polyarylene oxides, polyvinylpyrrolidones, polyvinylalcohols, hydroxy alkyl celluloses, algin, saccharides, caprolactones, and the like, and mixtures and combinations thereof. Hydrophilic polymers may be blended among themselves or with formulated amounts of water insoluble compounds (including some polymers) to yield coatings with suitable lubricity, bonding, and solubility. Some other examples of such coatings and materials and methods used to create such coatings can be found in U.S. Pat. Nos. 6,139,510 and 5,772,609, which are incorporated herein by reference.

[0081] The coating and/or sheath may be formed, for example, by coating, extrusion, co-extrusion, interrupted layer co-extrusion (ILC), or fusing several segments end-to-end. The layer may have a uniform stiffness or a gradual reduction in stiffness from the proximal end to the distal end

thereof. The gradual reduction in stiffness may be continuous as by ILC or may be stepped as by fusing together separate extruded tubular segments. The outer layer may be impregnated with a radiopaque filler material to facilitate radiographic visualization. Those skilled in the art will recognize that these materials can vary widely without deviating from the scope of the present invention.

[0082] The entire disclosures of the following documents are herein incorporated by reference in their entirety:

[0083] U.S. Patent Application Pub No. US 2007/0112355,

[0084] U.S. Patent Application Pub No. US 2010/0219092,

[0085] U.S. Patent Application Pub No. US 2010/0280495,

[0086] U.S. patent application Ser. No. 12/578,447, filed on Oct. 13, 2009 and entitled “Medical Devices and Delivery Systems for Delivering Medical Devices” (Attorney Docket Number: 1001.2627101),

[0087] U.S. Patent Application Ser. No. 61/559,914, filed on Nov. 15, 2011 and entitled “Duel Sterilization Containment Vessel” (Attorney Docket Number: 1001.2741100),

[0088] U.S. Patent Application Ser. No. 61/559,892, filed on Nov. 15, 2011 and entitled “Improved Bond Between Components of a Medical Device” (Attorney Docket Number: 1001.2742100),

[0089] U.S. Patent Application Ser. No. 61/559,941, filed on Nov. 15, 2011 and entitled “Medical Device With One Or More Sheathing Transition Members” (Attorney Docket Number: 1001.2743100),

[0090] U.S. Patent Application Ser. No. 61/559,871, filed on Nov. 15, 2011 and entitled “Medical Device with Nosecone and Nosecone Tube Extension” (Attorney Docket Number: 1001.2744100),

[0091] U.S. Patent Application Ser. No. 61/559,931, filed on Nov. 15, 2011 and entitled “Medical Device With Keyed Locking Structures” (Attorney Docket Number: 1001.2746100),

[0092] U.S. Patent Application Ser. No. 61/566,615, filed on Dec. 3, 2011 and entitled “Medical Device Handle” (Attorney Docket Number: 1001.2747100),

[0093] U.S. Patent Application Ser. No. 61/577,845, filed on Dec. 20, 2011 and entitled “Medical Device Handle” (Attorney Docket Number: 1001.2748100),

[0094] U.S. Patent Application Ser. No. 61/577,880, filed on Dec. 20, 2011 and entitled “Apparatus for Endovascularly Replacing a Heart Valve” (Attorney Docket Number: 1001.2749100),

[0095] U.S. Patent Application Ser. No. 61/577,891, filed on Dec. 20, 2011 and entitled “Heart Valve Replacement Catheter” (Attorney Docket Number: 1001.2751100), and

[0096] U.S. Patent Application Ser. No. 61/543,521, filed on Oct. 5, 2011 and entitled “Profile Reduction Seal” (Attorney Docket Number: 1001.2752100).

[0097] It should be understood that this disclosure is, in many respects, only illustrative. Changes may be made in details, particularly in matters of shape, size, and arrangement of steps without exceeding the scope of the invention. This may include, to the extent that it is appropriate, the use of any of the features of one example embodiment being used in other embodiments. The invention’s scope is, of course, defined in the language in which the appended claims are expressed.

What is claimed is:

1. A medical device, comprising:
 - a handle housing having a proximal end, a distal end, a longitudinal axis extending from the proximal end to the distal end, and an interior space therein;
 - wherein the handle housing includes a side wall defining the interior space and extending from the proximal end to the distal end, a proximal aperture extending through the side wall of the handle housing to the interior space, and a distal aperture extending through the side wall of the handle housing to the interior space;
 - an elongated outer sheath having a lumen therein extending distally from the distal end of the handle housing;
 - an elongated inner member extending distally through the distal end of the handle housing within the lumen of the elongated outer sheath;
 - a proximal flush port disposed within the interior space and in fluid communication with the elongated inner member; and
 - a distal flush port disposed within the interior space and in fluid communication with the lumen of the elongated outer sheath.
2. The medical device of claim 1, further comprising a sheath adapter disposed within and axially movable within the interior space;
 - wherein the distal flush port is attached to the sheath adapter.
3. The medical device of claim 2, wherein the elongated outer sheath is fixed to and extends distally from the sheath adapter.
4. The medical device of claim 2, wherein the elongated inner member extends distally through the sheath adapter and into the lumen of the elongated outer sheath.
5. The medical device of claim 1, wherein the distal flush port is configured to be directly accessible from an exterior of the handle housing through the distal aperture.
6. The medical device of claim 1, wherein the proximal flush port is configured to be directly accessible from an exterior of the handle housing through the proximal aperture.
7. The medical device of claim 1, wherein the elongated inner member is fixed in position relative to the handle housing.
8. The medical device of claim 1, wherein the elongated outer sheath is axially movable relative to the handle housing.
9. The medical device of claim 1, wherein the elongated inner member includes at least three lumens extending longitudinally through the elongated inner member.
10. The medical device of claim 1, further comprising a diverter and a support body fixedly attached to a proximal end of the diverter;
 - wherein the diverter and the support body are fixed in position relative to the handle housing;
 - wherein the proximal flush port is attached to the support body.
11. The medical device of claim 10, wherein the elongated inner member is fixed to and extends distally from the diverter.
12. The medical device of claim 10, wherein support body includes two lumens extending longitudinally therethrough.
13. The medical device of claim 12, wherein the proximal flush port is in fluid communication with the two lumens of the support body.
14. The medical device of claim 13, wherein the elongated inner member includes at least three lumens extending longitudinally through the elongated inner member;
 - wherein at least two of the at least three lumens of the elongated inner member are in fluid communication with the proximal flush port.
15. A medical device, comprising:
 - a handle housing having a proximal end, a distal end, a longitudinal axis extending from the proximal end to the distal end, and an interior space therein;
 - wherein the handle housing includes a side wall defining the interior space and extending from the proximal end to the distal end, a proximal aperture extending through the side wall of the handle housing to the interior space, and a distal aperture extending through the side wall of the handle housing to the interior space;
 - an elongated outer sheath having a lumen therein extending distally from the distal end of the handle housing;
 - an elongated inner member extending distally through the distal end of the handle housing within the lumen of the elongated outer sheath;
 - a proximal flush port fixedly disposed within the interior space and in fluid communication with the elongated inner member;
 - a distal flush port movably disposed within the interior space and in fluid communication with the lumen of the elongated outer sheath; and
 - a control knob at the proximal end of the handle housing; wherein rotating the control knob relative to the handle housing moves the distal flush port longitudinally within the interior space.
16. The medical device of claim 15, wherein the elongated outer sheath is fixed in position relative to the distal flush port.
17. The medical device of claim 15, wherein the elongated inner member is fixed in position relative to the proximal flush port.
18. The medical device of claim 15, wherein fluid introduced into the proximal flush port passes through the elongated inner member and does not enter the lumen of the elongated outer sheath.
19. The medical device of claim 15, wherein fluid introduced into the distal flush port passes through the lumen of the elongated outer sheath and does not enter the elongated inner member.
20. A medical device, comprising:
 - a handle housing having a proximal end, a distal end, and a longitudinal axis extending from the proximal end to the distal end;
 - wherein the handle housing includes a side wall having laterally-facing proximal and distal apertures extending therethrough;
 - an elongated outer sheath having a lumen therein extending distally from the distal end of the handle housing;
 - an elongated inner member extending distally through the distal end of the handle housing within the lumen of the elongated outer sheath;
 - a laterally-facing proximal flush port fixedly disposed within the handle housing and in fluid communication with the elongated inner member;
 - a laterally-facing distal flush port movably disposed within the handle housing and in fluid communication with the lumen of the elongated outer sheath; and
 - a control knob disposed about the proximal end of the handle housing;

wherein rotating the control knob about the handle housing
moves the distal flush port relative to the handle housing
in a direction parallel to the longitudinal axis.

* * * * *