



US 20130128637A1

(19) **United States**

(12) **Patent Application Publication**
Humphrey et al.

(10) **Pub. No.: US 2013/0128637 A1**
(43) **Pub. Date: May 23, 2013**

(54) **POWER RAIL REGULATOR SYSTEM**
(75) Inventors: **Daniel Humphrey**, Houston, TX (US);
Mohamed Amin Bemat, Cypress, TX (US)
(73) Assignee: **HEWLETT-PACKARD DEVELOPMENT COMPANY, L.P.**,
Houston, TX (US)

(52) **U.S. Cl.**
CPC .. **G05F 1/46** (2013.01); **H02M 7/04** (2013.01)
USPC **363/84; 323/234**

(21) Appl. No.: **13/814,043**
(22) PCT Filed: **Sep. 13, 2010**
(86) PCT No.: **PCT/US10/48660**
§ 371 (c)(1),
(2), (4) Date: **Feb. 4, 2013**

(57) **ABSTRACT**

A power regulators system and method is disclosed. In one embodiment, a power regulator system (10) is provided and includes at least one power supply (16) each configured to convert a DC rail voltage to a DC load voltage. The DC load voltage can be less than the DC rail voltage and can be provided to power at least one electronic component. The system (10) also includes a power rail regulator (12) configured to generate the DC rail voltage based on an input voltage and to regulate a magnitude of the DC rail voltage to vary between a minimum voltage magnitude and a maximum voltage magnitude and to regulate a variable magnitude of an output current. The DC rail voltage and the output current can be regulated based on load requirements associated with the at least one electronic component (18).

Publication Classification

(51) **Int. Cl.**
G05F 1/46 (2006.01)
H02M 7/04 (2006.01)

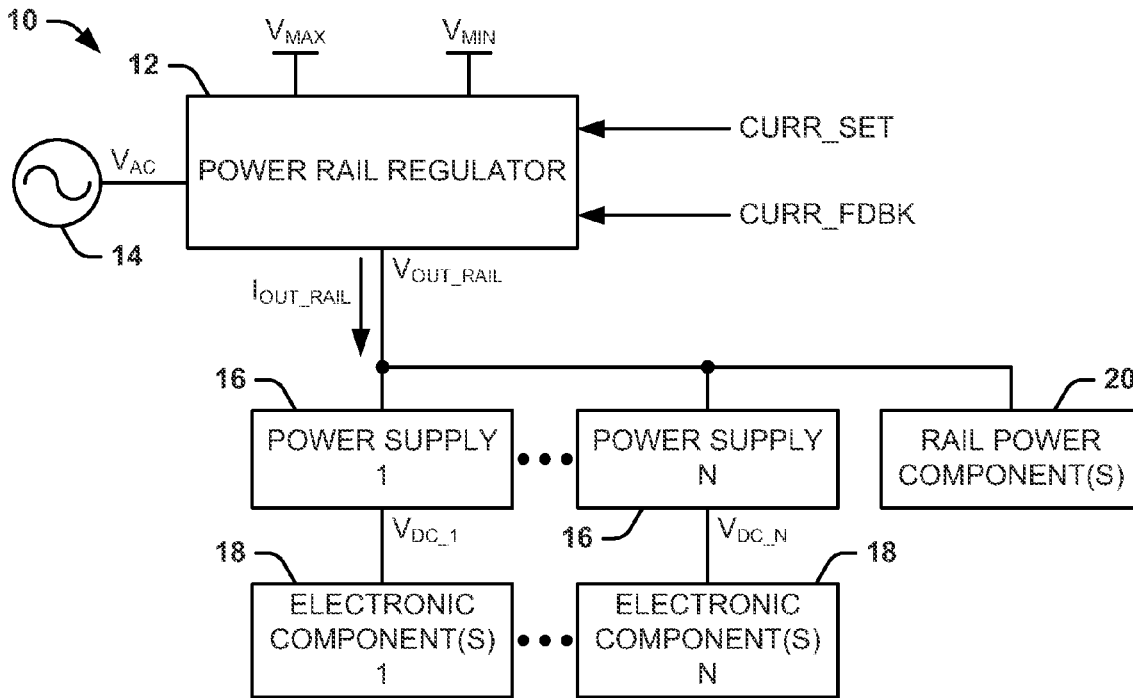

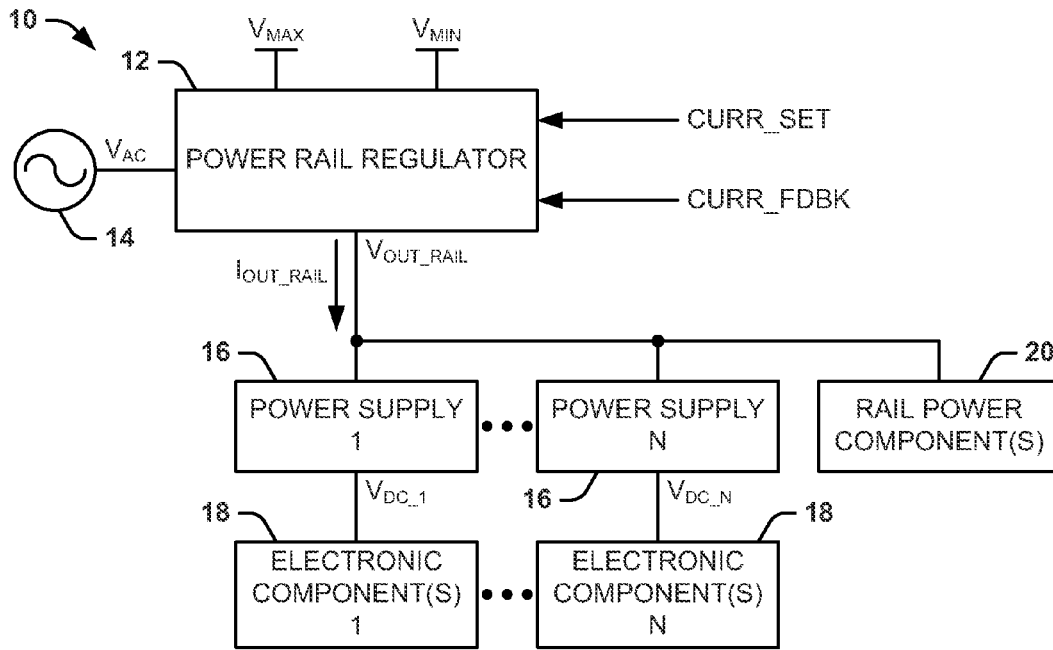

FIG. 1

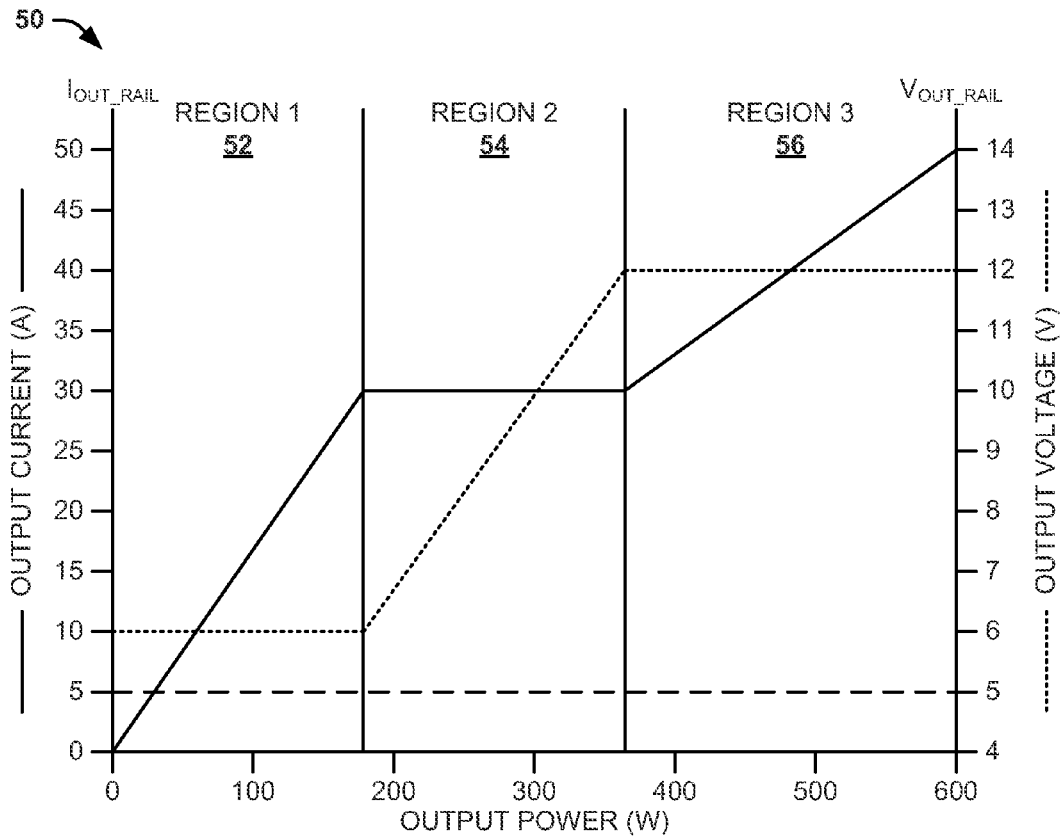

FIG. 2

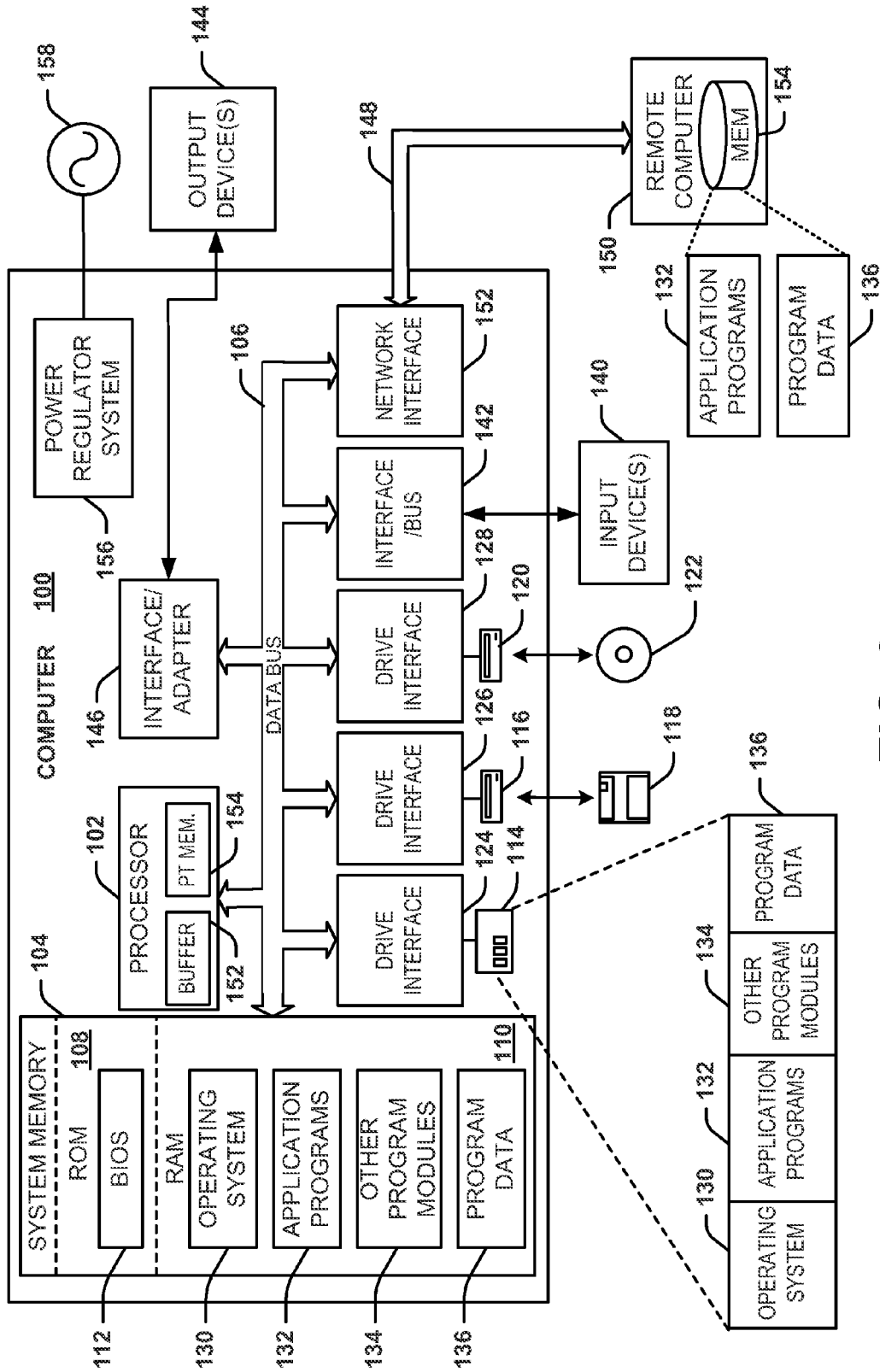

FIG. 3

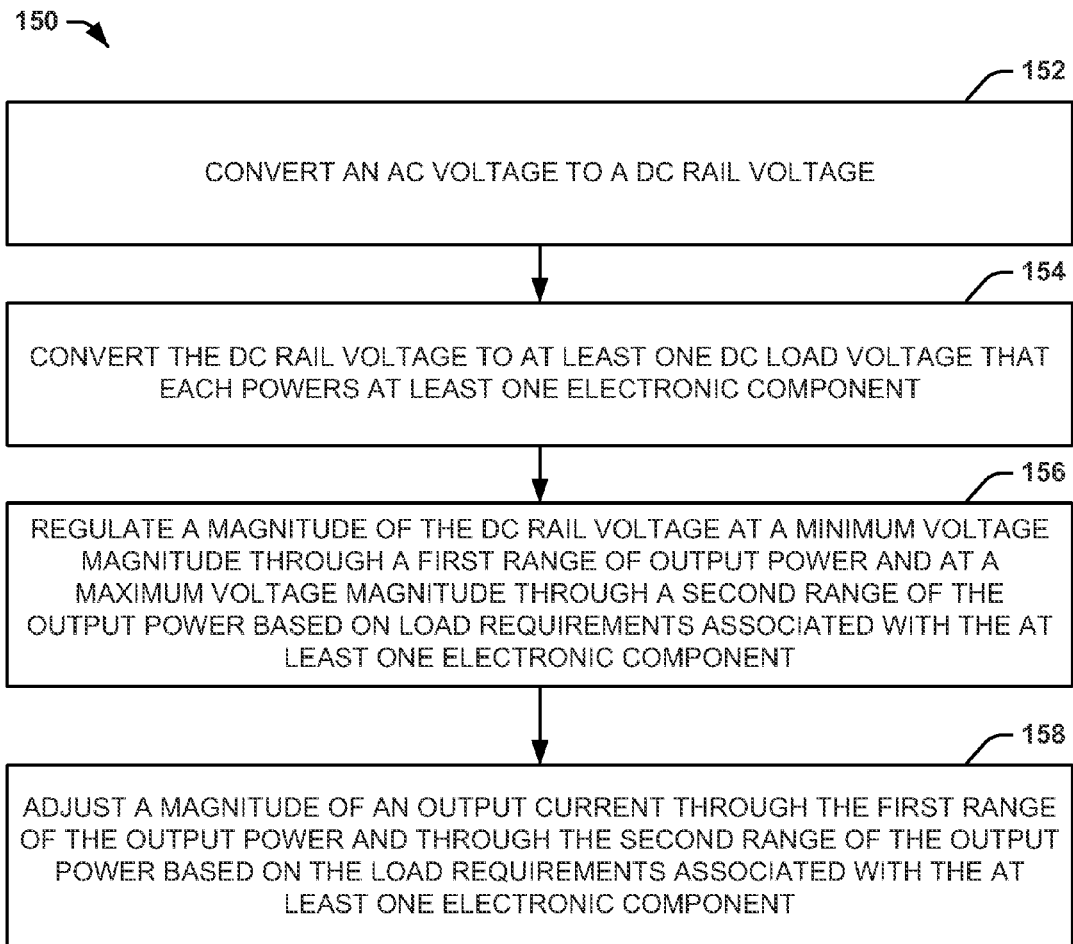

FIG. 4

POWER RAIL REGULATOR SYSTEM

BACKGROUND

[0001] Computer systems may include different loads that require varied voltages. The varied voltages may require power converters to take a common bus or rail voltage and convert it to meet the required input power characteristics for the load. As an example, a given computer system can include a power rail, such as a 12 volt power rail. The power rail can be used as a bus to power system components, or it can be regulated down to provide the power requirements of a specific load, such as some combination of 3.3 volts and/or 5 volts.

BRIEF DESCRIPTION OF THE DRAWINGS

[0002] FIG. 1 illustrates an example embodiment of a power regulator system.

[0003] FIG. 2 illustrates an example embodiment of a graph of output voltage and output current for a power rail regulator.

[0004] FIG. 3 illustrates an example embodiment of a computer system.

[0005] FIG. 4 illustrates an example embodiment of a method for providing power.

DETAILED DESCRIPTION

[0006] FIG. 1 illustrates an example embodiment of a power regulator system 10. The power regulator system 10 can be included in any of a variety of electronic systems, such as computer systems and/or portable electronic devices. The power regulator system 10 includes a power rail regulator 12 that is configured to convert an AC voltage V_{AC} generated from an AC voltage source 14 to a DC output rail voltage V_{OUT_RAIL} . As an example, the AC voltage V_{AC} can be a 120 volt, 60 Hz, AC voltage, such as received from a wall outlet. However, it is to be understood that the AC voltage source 14 in the example of FIG. 1 could instead be implemented as a DC voltage source, such that the power rail regulator 12 converts a DC voltage to the DC output rail voltage V_{OUT_RAIL} . In the example of FIG. 1, the power rail regulator 12 also generates an output current I_{OUT_RAIL} .

[0007] The power regulator system 10 also includes a plurality N of power supplies 16, where N is a positive integer. Each of the power supplies 16 can be configured as buck, boost, and/or buck boost converters to convert the DC output rail voltage V_{OUT_RAIL} to DC voltages V_{DC_1} through V_{DC_N} , respectively. As an example, the DC voltages V_{DC_1} through V_{DC_N} can be any combination of voltage magnitudes, such as 3.3 volts and/or 5 volts. The DC voltages V_{DC_1} through V_{DC_N} are each provided to power respective one or more electronic components 18, demonstrated in the example of FIG. 1 as ELECTRONIC COMPONENT(S) 1 through ELECTRONIC COMPONENT(S) N. As an example, the electronic component(s) 18 can include a variety of electronic components, such as computer circuits, chips, and/or processors. In addition, the power regulator system 10 also includes one or more rail power components 20, such as fans and/or motors, that are each powered directly from the DC output voltage V_{OUT_RAIL} .

[0008] In the example of FIG. 1, the power rail regulator 12 is configured to vary the magnitude of the DC output rail voltage V_{OUT_RAIL} and the output current I_{OUT_RAIL} , such as based on load requirements associated with the electronic component(s) 18 and/or the rail power component(s) 20. As

an example, the power rail regulator 12 can monitor a feedback signal, demonstrated in the example of FIG. 1 as the signal CURR_FDBK, that is indicative of the power consumption of the electronic component(s) 18 and/or the rail power component(s) 20. As an example, the signal CURR_FDBK could be implemented to provide current consumption information associated with the one or more electronic component(s) 18 and/or the one or more rail power component(s) 20. Alternatively, the signal CURR_FDBK could provide other information indicative of the power consumption of the electronic component(s) 18 and/or the rail power component(s) 20. Thus, the power rail regulator 12 can generate the DC output rail voltage V_{OUT_RAIL} as having a magnitude that varies from a minimum magnitude to a maximum magnitude, demonstrated in the example of FIG. 1 as voltages V_{MIN} and V_{MAX} , respectively. Therefore, the DC output rail voltage V_{OUT_RAIL} can be generated at lower magnitudes during light load conditions, such as to substantially maximize the efficiencies of the power supplies 16 during light load conditions.

[0009] As an example, the power rail regulator 12 can be configured to regulate the DC output rail voltage V_{OUT_RAIL} and the output current I_{OUT_RAIL} in different regions that each span a range of output power associated with the power rail regulator 12. In each of the regions, one of the DC output rail voltage V_{OUT_RAIL} and the output current I_{OUT_RAIL} can be alternately held at a substantially constant magnitude. For example, the power rail regulator 12 can generate the DC output rail voltage V_{OUT_RAIL} at a substantially constant minimum magnitude V_{MIN} in a first region spanning a range of output power from zero to a first predetermined output power and can generate the DC output rail voltage V_{OUT_RAIL} at a substantially constant maximum magnitude V_{MAX} in a last region spanning a range of output power from a second predetermined output power to a maximum power.

[0010] FIG. 2 illustrates an example embodiment of a graph 50 of output voltage and output current for a power rail regulator. The power rail regulator can correspond to the power rail regulator 12 in the example of FIG. 1. Therefore, reference is to be made to the example of FIG. 1 in the following description of the example of FIG. 2.

[0011] The graph 50 includes a first vertical axis on which the output current I_{OUT_RAIL} is demonstrated in amps and a second vertical axis on which the DC output rail voltage V_{OUT_RAIL} is demonstrated in volts. The graph 50 also includes a horizontal axis on which the output power of the power rail regulator 12 is demonstrated in watts. In the example of FIG. 2, the output current I_{OUT_RAIL} is plotted as a solid line, while the DC output rail voltage V_{OUT_RAIL} is plotted as a dotted line.

[0012] The graph 50 demonstrates the regulation of the DC output rail voltage V_{OUT_RAIL} and the output current I_{OUT_RAIL} in three regions 52, 54, and 56, demonstrated as REGION 1, REGION 2, and REGION 3. Each span a range of the output power associated with the power rail regulator 12. The first region 52 is demonstrated as spanning zero watts to approximately 180 watts. Therefore, the first region 52 can define a substantially light load operating region of the power supply system 10. In the first region 52, the DC output rail voltage V_{OUT_RAIL} is regulated at a substantially constant magnitude of approximately 6 volts. As an example, the 6 volts could be the minimum voltage magnitude V_{MIN} associated with the power rail regulator 12. As the load requirements of the electronic components 18 and/or the rail power

components **20** increase through the first region **52**, the power rail regulator **12** increases the output current I_{OUT_RAIL} to meet the required power.

[0013] The second region **54** is demonstrated as spanning approximately 180 watts to approximately 360 watts. The second region **54** can be defined based on a programmable setpoint for the output current I_{OUT_RAIL} , such as provided by a signal CURR_SET demonstrated in the example of FIG. 1. As an example, the programmable setpoint for the output current I_{OUT_RAIL} can be based on tradeoffs between conductive losses and converter efficiency gains. In the second region **54**, the output current I_{OUT_RAIL} is regulated at a substantially constant magnitude of approximately 30 amps. As the load requirements of the electronic components **18** and/or the rail power components **20** increase through the second region **54**, the power rail regulator **12** increases the DC output rail voltage V_{OUT_RAIL} to meet the required power.

[0014] The third region **56** is demonstrated as spanning approximately 360 watts to approximately 600 watts, which could be a maximum power output associated with the power rail regulator **12**. The third region **56** can be defined based on the DC output rail voltage V_{OUT_RAIL} increasing to the maximum magnitude V_{MAX} . Thus, in the third region **56**, the DC output rail voltage V_{OUT_RAIL} is regulated at a substantially constant magnitude of approximately 12 volts (e.g., the maximum magnitude V_{MAX}). As the load requirements of the electronic components **18** and/or the rail power components **20** increase through the second region **54**, the power rail regulator **12** increases the output current I_{OUT_RAIL} to meet the required power, up to the approximately maximum output power of the power rail regulator **12** (e.g., 600 watts).

[0015] Power supplies that generate a DC output voltage from a higher DC source voltage typically operate less efficiently as the difference between the higher DC source voltage and the DC output voltage increases. The power rail regulator **12** thus regulates the DC output rail voltage V_{OUT_RAIL} and the output current I_{OUT_RAIL} more efficiently than typical power rail regulators. Specifically, during light load conditions, the power rail regulator **12** operates in the first region **52**, thus generating the DC output rail voltage V_{OUT_RAIL} at the substantially constant minimum magnitude V_{MIN} . As a result, the power supplies **16** generate the DC voltages V_{DC_1} through V_{DC_N} from a source voltage of approximately 6 volts in the example of FIG. 2, as opposed to a higher voltage that is suitable for any load conditions. Accordingly, the power rail regulator **12** is much more efficient during light load conditions associated with the electronic components **18** and/or the rail power components **20**.

[0016] In addition, the current setpoint that defines the second region **54** is programmable based on the signal CURR_SET. Thus, the operation of the power rail regulator **12** can be flexibly adjusted to balance conductive losses of the electronic components **18** and/or the rail power components **20** relative to the efficiency gains of the power supplies **16**. In addition, the power rail regulator **12** can be configured to regulate the DC output rail voltage V_{OUT_RAIL} and the output current I_{OUT_RAIL} in more or less than just three regions. As an example, the power rail regulator **12** can be configured to regulate the DC output rail voltage V_{OUT_RAIL} and the output current I_{OUT_RAIL} in any integer of regions, with the DC output rail voltage V_{OUT_RAIL} being regulated at the minimum voltage V_{MIN} in the first region and at the maximum voltage V_{MAX} in the last region. As another example, the power rail regulator **12** can be configured to regulate the DC

output rail voltage V_{OUT_RAIL} and the output current I_{OUT_RAIL} in just two regions, with the DC output rail voltage V_{OUT_RAIL} being regulated at the minimum voltage V_{MIN} in the first region and at the maximum voltage V_{MAX} in the last region, with the magnitude of the output current I_{OUT_RAIL} varying accordingly in both regions. Furthermore, the power rail regulator **12** could be configured to regulate the DC output rail voltage V_{OUT_RAIL} in step-wise voltage increments, such as to approximate a substantially constant current, or even to include a negative slope of the output current I_{OUT_RAIL} .

[0017] Therefore, the signal CURR_SET can be implemented to set multiple current setpoints in intermediate regions, thus allowing further flexibility of the operation of the power rail regulator **12**. Furthermore, it is to be understood that the regions **52**, **54**, and **56** are not limited to maintaining one of the DC output rail voltage V_{OUT_RAIL} and the output current I_{OUT_RAIL} at a constant magnitude, but could instead regulate both of the DC output rail voltage V_{OUT_RAIL} and the output current I_{OUT_RAIL} at variable magnitudes in each of the regions. Thus, the power rail regulator **12** can be configured in a variety of ways.

[0018] While it is described herein that the regions **52**, **54**, and **56** span a range of output power associated with the power rail regulator **12**, it should be noted that the regions **52**, **54**, and **56** can instead be considered as defined by the magnitude of the output current I_{OUT_RAIL} based on the relationship of the output current I_{OUT_RAIL} with the DC output rail voltage V_{OUT_RAIL} and based on the DC output rail voltage V_{OUT_RAIL} being substantially constant in the first and last regions **52** and **56**. Thus, as described herein, it is to be understood that the definitions of the boundaries between the regions **52**, **54**, and **56** can be based on output power or the magnitude of the output current I_{OUT_RAIL} .

[0019] FIG. 3 illustrates an example of a computer system **100** that can be employed to implement systems and methods described herein, such as based on computer executable instructions running on the computer system. The computer system **100** can be implemented on one or more general purpose networked computer systems, embedded computer systems, routers, switches, server devices, client devices, various intermediate devices/nodes and/or stand alone computer systems. Additionally, the computer system **100** can be implemented as part of a network analyzer or associated design tool running computer executable instructions to perform methods and functions, as described herein.

[0020] The computer system **100** includes a processor **102** and a system memory **104**. A system bus **106** couples various system components, including the system memory **104** to the processor **102**. Dual microprocessors and other multi-processor architectures can also be utilized as the processor **102**. The system bus **106** can be implemented as any of several types of bus structures, including a memory bus or memory controller, a peripheral bus, and a local bus using any of a variety of bus architectures. The system memory **104** includes read only memory (ROM) **108** and random access memory (RAM) **110**. A basic input/output system (BIOS) **112** can reside in the ROM **108**, generally containing the basic routines that help to transfer information between elements within the computer system **100**, such as a reset or power-up.

[0021] The computer system **100** can include a hard disk drive **114**, a magnetic disk drive **116**, e.g., to read from or write to a removable disk **118**, and an optical disk drive **120**, e.g., for reading a CD-ROM or DVD disk **122** or to read from

or write to other optical media. The hard disk drive **114**, magnetic disk drive **116**, and optical disk drive **120** are connected to the system bus **106** by a hard disk drive interface **124**, a magnetic disk drive interface **126**, and an optical drive interface **134**, respectively. The drives and their associated computer-readable media provide nonvolatile storage of data, data structures, and computer-executable instructions for the computer system **100**. Although the description of computer-readable media above refers to a hard disk, a removable magnetic disk and a CD, other types of media which are readable by a computer, may also be used. For example, computer executable instructions for implementing systems and methods described herein may also be stored in magnetic cassettes, flash memory cards, digital video disks and the like. A number of program modules may also be stored in one or more of the drives as well as in the RAM **110**, including an operating system **130**, one or more application programs **132**, other program modules **134**, and program data **136**.

[0022] A user may enter commands and information into the computer system **100** through user input device **140**, such as a keyboard, a pointing device (e.g., a mouse). Other input devices may include a microphone, a joystick, a game pad, a scanner, a touch screen, or the like. These and other input devices are often connected to the processor **102** through a corresponding interface or bus **142** that is coupled to the system bus **106**. Such input devices can alternatively be connected to the system bus **106** by other interfaces, such as a parallel port, a serial port or a universal serial bus (USB). One or more out device(s) **144**, such as a visual display device or printer, can also be connected to the system bus **106** via an interface or adapter **146**.

[0023] The computer system **100** may operate in a networked environment using logical connections **148** to one or more remote computers **150**. The remote computer **148** may be a workstation, a computer system, a router, a peer device or other common network node, and typically includes many or all of the elements described relative to the computer system **100**. The logical connections **148** can include a local area network (LAN) and a wide area network (WAN).

[0024] When used in a LAN networking environment, the computer system **100** can be connected to a local network through a network interface **152**. When used in a WAN networking environment, the computer system **100** can include a modem (not shown), or can be connected to a communications server via a LAN. In a networked environment, application programs **132** and program data **136** depicted relative to the computer system **100**, or portions thereof, may be stored in memory **154** of the remote computer **150**.

[0025] By way of further example, the computer system **100** includes a power regulator system **156**. The power regulator system **156** can be configured substantially similar to the power regulator system **10** in the example of FIG. 1. Specifically, the power regulator system **156** can include a power rail regulator, such as the power rail regulator **12** in the example of FIG. 1, that can generate a DC output rail voltage from an AC voltage generated by an AC voltage source **158**. The power rail regulator can vary the magnitude of the DC output rail voltage and an associated output current, such as based on load requirements associated with other electronic components in the computer system **100**. As an example, the power rail regulator can regulate the DC output rail voltage and the associated output current in a number of regions that each span a range of output power of the power rail regulator, such as demonstrated in the example of FIG. 2. Thus, additional

power supplies that generate DC voltages that power the other electronic components in the computer system **100** can operate more efficiently, such as during light load conditions.

[0026] In view of the foregoing structural and functional features described above, an example methodology will be better appreciated with reference to FIG. 4. While, for purposes of simplicity of explanation, the methodology of FIG. 4 is shown and described as executing serially, it is to be understood and appreciated that the present invention is not limited by the illustrated order, as some embodiments could in other embodiments occur in different orders and/or concurrently from that shown and described herein.

[0027] FIG. 4 illustrates an example embodiment of a method **150** for providing power. At **152**, an AC voltage is converted to a DC rail voltage. At **154**, the DC rail voltage is converted to at least one DC load voltage that each powers at least one electronic component. At **156**, a magnitude of the DC rail voltage is regulated at a minimum voltage magnitude through a first range of output power and at a maximum voltage magnitude through a second range of the output power based on load requirements associated with the at least one electronic component. At **158**, a magnitude of the output current associated with the DC rail voltage is adjusted through the first range of the output power and through the second range of the output power based on the load requirements associated with the at least one electronic component.

[0028] What have been described above are examples of the invention. It is, of course, not possible to describe every conceivable combination of components or methodologies for purposes of describing the invention, but one of ordinary skill in the art will recognize that many further combinations and permutations of the invention are possible. Accordingly, the invention is intended to embrace all such alterations, modifications, and variations that fall within the scope of this application, including the appended claims.

What is claimed is:

1. A power regulator system OM comprising:
 - at least one power supply configured to convert a DC rail voltage to a DC load voltage, the DC load voltage being less than the DC rail voltage and being provided to power at least one electronic component; and
 - a power rail regulator configured to generate the DC rail voltage based on an input voltage and to regulate a magnitude of the DC rail voltage to vary between a minimum voltage magnitude and a maximum voltage magnitude and to regulate a variable magnitude of an output current, the DC rail voltage and the output current being regulated based on load requirements associated with the at least one electronic component.
2. The system of claim 1, wherein the power rail regulator is configured to regulate the DC rail voltage and the output current in N regions across a range of output power, where N is an integer greater than one, the regions being defined as alternating between a substantially constant magnitude of the DC rail voltage with a variable magnitude of the output current and a substantially constant magnitude of the output current with a variable magnitude of the DC rail voltage.
3. The system of claim 2, wherein a first of the N regions is defined as the DC rail voltage having a substantially constant magnitude that is approximately equal to the minimum voltage magnitude at a range of the output power from zero to a first power magnitude, and wherein a last of the N regions is defined as the DC rail voltage having a substantially constant magnitude that is approximately equal to the maximum volt-

age magnitude at a range of the output power from a second power magnitude to a maximum power magnitude.

4. The system of claim **3**, wherein the first and second power magnitudes are each programmable.

5. The system of claim **1**, wherein the minimum and maximum voltage magnitudes are each programmable.

6. The system of claim **1**, further comprising at least one additional electronic component (k2-0) that is powered directly from the DC rail voltage.

7. A computer system comprising the power regulator system of claim **1**.

8. A method for providing power, the method comprising: converting an AC voltage to a DC rail voltage;

converting the DC rail voltage to at least one DC load voltage that each powers at least one electronic component;

regulating a magnitude of the DC rail voltage at a minimum voltage magnitude through a first range of output power and at a maximum voltage magnitude through a second range of output power based on load requirements associated with the at least one electronic component; and adjusting a magnitude of an output current associated with the DC rail voltage through the first range of the output power and through the second range of the output power based on the load requirements associated with the at least one electronic component.

9. The method of claim **8**, further comprising holding a magnitude of the output current substantially constant through a third range of output power that is between the first range of output power and the second range of output power.

10. The method of claim **9**, further comprising setting the substantially constant magnitude of the output current in the third range of output power based on conductive losses associated with the at least one electronic component.

11. The method of claim **8**, further comprising holding a magnitude of the DC rail voltage substantially constant through a third range of output power that is between the first range of output power and the second range of output power.

12. The method of claim **8**, further comprising programming the minimum voltage magnitude and the maximum voltage magnitude.

13. A power regulator system comprising:

at least one power supply each configured to convert a DC rail voltage to a DC load voltage, the DC load voltage being less than the DC rail voltage and being provided to power at least one electronic component; and

a power rail regulator configured to generate the DC rail voltage based on an AC voltage and to regulate a magnitude of the DC rail voltage and an output current through N regions across a range of output power, where N is an integer greater than one, such that one of the DC rail voltage and the output current is alternately substantially constant in each of the N regions based on load requirements associated with the at least one electronic component.

14. The system of claim **13**, wherein the power rail regulator is configured to vary the DC rail voltage between a programmable minimum voltage magnitude in a first of the N regions and a programmable maximum voltage magnitude in a last of the N regions.

15. The system of claim **13**, wherein the output current has a substantially constant magnitude in at least one of the N regions, the substantially constant magnitude being set based on conductive losses associated with the at least one electronic component.

* * * * *