

(19) World Intellectual Property Organization
International Bureau



(43) International Publication Date
22 January 2004 (22.01.2004)

PCT

(10) International Publication Number
WO 2004/008183 A3

(51) International Patent Classification⁷: G01V 3/12, 3/15

(21) International Application Number:
PCT/GB2003/002379

(22) International Filing Date: 30 May 2003 (30.05.2003)

(25) Filing Language: English

(26) Publication Language: English

(30) Priority Data:
0216555.3 16 July 2002 (16.07.2002) GB

(71) Applicant (for all designated States except US): UNIVERSITY OF SOUTHAMPTON [GB/GB]; Highfield, Southampton, Hampshire SO17 1BJ (GB).

(72) Inventors; and

(75) Inventors/Applicants (for US only): MACGREGOR, Lucy, M. [GB/GB]; Centre for Enterprise & Innovation, University of Southampton, Highfield, Southampton, Hampshire SO17 1BJ (GB). RUST, Jennifer, L. [GB/GB]; Centre for Enterprise & Innovation, University of Southampton, Highfield, Southampton, Hampshire SO17 1BJ (GB). SINHA, Martin, C. [GB/GB]; Centre

for Enterprise & Innovation, University of Southampton, Highfield, Southampton, Hampshire SO17 1BJ (GB).

(74) Agent: HAINES, Miles, John; D. Young & Co., 21 New Fetter Lane, London EC4A 1DA (GB).

(81) Designated States (national): AE, AG, AL, AM, AT, AU, AZ, BA, BB, BG, BR, BY, BZ, CA, CH, CN, CO, CR, CU, CZ, DE, DK, DM, DZ, EC, EE, ES, FI, GB, GD, GE, GH, GM, HR, HU, ID, IL, IN, IS, JP, KE, KG, KP, KR, KZ, LC, LK, LR, LS, LT, LU, LV, MA, MD, MG, MK, MN, MW, MX, MZ, NI, NO, NZ, OM, PH, PL, PT, RO, RU, SC, SD, SE, SG, SK, SL, TJ, TM, TN, TR, TT, TZ, UA, UG, US, UZ, VC, VN, YU, ZA, ZM, ZW.

(84) Designated States (regional): ARIPO patent (GH, GM, KE, LS, MW, MZ, SD, SL, SZ, TZ, UG, ZM, ZW), Eurasian patent (AM, AZ, BY, KG, KZ, MD, RU, TJ, TM), European patent (AT, BE, BG, CH, CY, CZ, DE, DK, EE, ES, FI, FR, GB, GR, HU, IE, IT, LU, MC, NL, PT, RO, SE, SI, SK, TR), OAPI patent (BF, BJ, CF, CG, CI, CM, GA, GN, GQ, GW, ML, MR, NE, SN, TD, TG).

Published:
— with international search report

[Continued on next page]

(54) Title: ELECTROMAGNETIC SURVEYING FOR HYDROCARBON RESERVOIRS

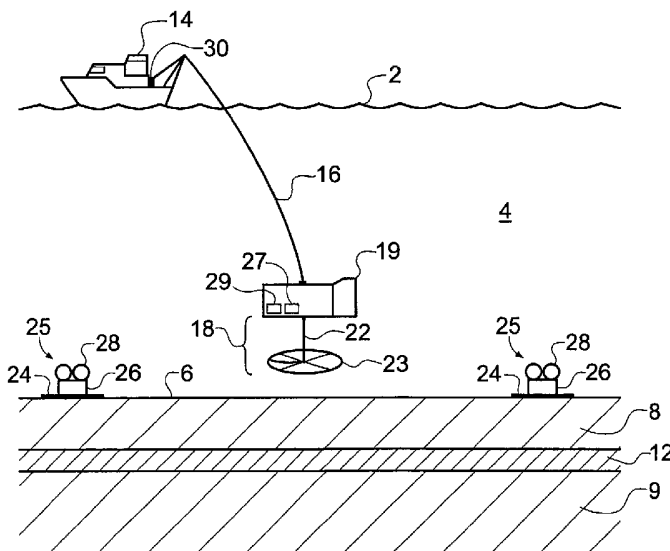

(57) Abstract: An electromagnetic survey method for surveying an area of seafloor (6) that is thought or known to contain a subterranean hydrocarbon reservoir (12), comprising obtaining a first survey data set with a vertical electric dipole (VED) antenna (22) for generating vertical current loops and a second survey data set with a vertical magnetic dipole (VMD) (23) antenna for generating horizontal current loops. In an alternative embodiment, the VMD antenna is dispensed with and the horizontal electromagnetic field is derived from the naturally occurring magnetotelluric (MT) electromagnetic field. In another alternative embodiment, the VED data is compared with a background geological model instead of VMD or MT data.

WO 2004/008183 A3



— *before the expiration of the time limit for amending the claims and to be republished in the event of receipt of amendments*

For two-letter codes and other abbreviations, refer to the "Guidance Notes on Codes and Abbreviations" appearing at the beginning of each regular issue of the PCT Gazette.

(88) Date of publication of the international search report:

1 April 2004

INTERNATIONAL SEARCH REPORT

International Application No
PCT/GB 03/02379

A. CLASSIFICATION OF SUBJECT MATTER IPC 7 G01V3/12 G01V3/15		
According to International Patent Classification (IPC) or to both national classification and IPC		
B. FIELDS SEARCHED		
Minimum documentation searched (classification system followed by classification symbols) IPC 7 G01V		
Documentation searched other than minimum documentation to the extent that such documents are included in the fields searched		
Electronic data base consulted during the international search (name of data base and, where practical, search terms used) EPO-Internal, WPI Data, PAJ		
C. DOCUMENTS CONSIDERED TO BE RELEVANT		
Category °	Citation of document, with indication, where appropriate, of the relevant passages	Relevant to claim No.
X	NEWMAN G.: "A STUDY OF DOWNHOLE ELECTROMAGNETIC SOURCES FOR MAPPING ENHANCED OIL RECOVERY PROCESSES" GEOPHYSICS, SOCIETY OF EXPLORATION GEOPHYSICISTS, vol. 59, no. 4, April 1994 (1994-04), pages 534-545, XP002252013 page 534, column 2, paragraph 2 page 535, column 1, paragraph 3 -column 2, paragraph 3 figures 1-5	1,4,5
Y	--- -/--	2,6, 22-30, 44-52
<input checked="" type="checkbox"/> Further documents are listed in the continuation of box C.		
<input checked="" type="checkbox"/> Patent family members are listed in annex.		
° Special categories of cited documents :		
"A" document defining the general state of the art which is not considered to be of particular relevance "E" earlier document but published on or after the international filing date "L" document which may throw doubts on priority claim(s) or which is cited to establish the publication date of another citation or other special reason (as specified) "O" document referring to an oral disclosure, use, exhibition or other means "P" document published prior to the international filing date but later than the priority date claimed		
"T" later document published after the international filing date or priority date and not in conflict with the application but cited to understand the principle or theory underlying the invention "X" document of particular relevance; the claimed invention cannot be considered novel or cannot be considered to involve an inventive step when the document is taken alone "Y" document of particular relevance; the claimed invention cannot be considered to involve an inventive step when the document is combined with one or more other such documents, such combination being obvious to a person skilled in the art. "&" document member of the same patent family		
Date of the actual completion of the international search <p style="text-align: center; font-weight: bold;">19 January 2004</p>	Date of mailing of the international search report <p style="text-align: center; font-weight: bold;">10. 02. 04</p>	
Name and mailing address of the ISA European Patent Office, P.B. 5818 Patentlaan 2 NL - 2280 HV Rijswijk Tel. (+31-70) 340-2040, Tx. 31 651 epo nl, Fax: (+31-70) 340-3016	Authorized officer <p style="text-align: center; font-weight: bold;">Schneiderbauer, K</p>	

INTERNATIONAL SEARCH REPORT

International Application No

PCT/GB 03/02379

C.(Continuation) DOCUMENTS CONSIDERED TO BE RELEVANT		
Category °	Citation of document, with indication, where appropriate, of the relevant passages	Relevant to claim No.
X	US 2002/079899 A1 (TABANOU JACQUES R ET AL) 27 June 2002 (2002-06-27) page 6, column 2, paragraph 103 -page 7, column 1, paragraph 105 ---	1,3
Y	CONSTABLE S C ET AL: "MARINE MAGNETOTELLURICS FOR PETROLEUM EXPLORATION PART 1: A SEA- FLOOR EQUIPMENT SYSTEM" GEOPHYSICS, SOCIETY OF EXPLORATION GEOPHYSICISTS. TULSA, US, vol. 63, no. 3, 1 May 1998 (1998-05-01), pages 816-825, XP000775937 ISSN: 0016-8033 cited in the application page 819, column 2, paragraph 2 -page 821, column 1, paragraph 3 figure 4 ---	2,22-30
A	EDWARDS R.N. ET AL.: "First results of the MOSES experiment: sea sediment conductivity and thickness determination, Bute Inlet, British Columbia, by magnetometric offshore electrical sounding" GEOPHYSICS, SOCIETY OF EXPLORATION GEOPHYSICISTS, vol. 50, no. 1, January 1985 (1985-01), pages 153-160, XP002252014 cited in the application page 154, column 2, paragraph 4 -page 157, column 1, paragraph 1 ---	1-5, 22-30
A	WO 02 14906 A (REES DAVID CHRISTOPHER ;PEDERSEN HANS MAGNE (NO); EIDESMO TERJE (N) 21 February 2002 (2002-02-21) cited in the application page 2, line 6 - line 27 figure 9 ---	22-30
Y	WITHERS ET AL.: "A case study of integrated hydrocarbon exploration through basalt" GEOPHYSICS, SOCIETY OF EXPLORATION GEOPHYSICISTS, vol. 59, no. 11, 1 November 1994 (1994-11-01), pages 1666-1679, XP002266840 page 1670 -page 1673; figure 8 ---	6
	-/--	

INTERNATIONAL SEARCH REPORT

International Application No
PCT/GB 03/02379

C.(Continuation) DOCUMENTS CONSIDERED TO BE RELEVANT		
Category *	Citation of document, with indication, where appropriate, of the relevant passages	Relevant to claim No.
A	<p>KELLET R ET AL: "THE EFFECTS OF SOURCE POLARIZATION IN CSAMT DATA OVER TWO MASSIVE SULFIDE DEPOSITS IN AUSTRALIA" GEOPHYSICS, SOCIETY OF EXPLORATION GEOPHYSICISTS. TULSA, US, vol. 58, no. 12, 1 December 1993 (1993-12-01), pages 1764-1772, XP000461110 ISSN: 0016-8033 page 1764, column 1, paragraph 1 -page 1765, column 1, paragraph 1 page 1765, column 2, paragraph 2 page 1766, column 2, paragraph 1 figure 1</p>	6
A	<p>URQUHART S A ET AL: "COMBINING CSAMT AND MT IN DIFFICULT EXPLORATION ENVIRONMENTS" THE LEADING EDGE, SOCIETY OF EXPLORATION GEOPHYSICISTS, US, vol. 16, no. 4, 1 April 1997 (1997-04-01), pages 383-384, XP000690152 ISSN: 1070-485X page 383, column 1, paragraph 2 page 384, column 2, paragraph 2 -column 3, paragraph 1</p>	6
A	<p>US 3 548 299 A (DUROUX JEAN ET AL) 15 December 1970 (1970-12-15) column 1, line 43 - line 61 column 4, line 6 - line 12 column 11, line 63 - line 68 claim 6; figure 4</p>	1,6,22
X	<p>US 5 905 657 A (CELNIKER GEORGE WILLIAM) 18 May 1999 (1999-05-18) column 4, line 16 - line 23 column 4, line 37 -column 5, line 3 column 6, line 3 - line 12 column 8, line 33 - line 44 figures 2,3</p>	7-21, 31-43
A	<p>US 4 679 174 A (GELFAND VALERY A) 7 July 1987 (1987-07-07) column 2, line 49 -column 3, line 2 claim 1</p>	7-21, 31-43
Y	<p>WO 98 11455 A (ALTAN MEHMET S ;PGS TENSOR INC (US); ROSS CHRISTOPHER P (US)) 19 March 1998 (1998-03-19) abstract; claim 1</p>	44-52

INTERNATIONAL SEARCH REPORT

International application No.
PCT/GB 03/02379

Box I Observations where certain claims were found unsearchable (Continuation of item 1 of first sheet)

This International Search Report has not been established in respect of certain claims under Article 17(2)(a) for the following reasons:

1. Claims Nos.:
because they relate to subject matter not required to be searched by this Authority, namely:

2. Claims Nos.:
because they relate to parts of the International Application that do not comply with the prescribed requirements to such an extent that no meaningful International Search can be carried out, specifically:

3. Claims Nos.:
because they are dependent claims and are not drafted in accordance with the second and third sentences of Rule 6.4(a).

Box II Observations where unity of invention is lacking (Continuation of item 2 of first sheet)

This International Searching Authority found multiple inventions in this international application, as follows:

see additional sheet

1. As all required additional search fees were timely paid by the applicant, this International Search Report covers all searchable claims.
2. As all searchable claims could be searched without effort justifying an additional fee, this Authority did not invite payment of any additional fee.
3. As only some of the required additional search fees were timely paid by the applicant, this International Search Report covers only those claims for which fees were paid, specifically claims Nos.:
4. No required additional search fees were timely paid by the applicant. Consequently, this International Search Report is restricted to the invention first mentioned in the claims; it is covered by claims Nos.:

Remark on Protest

The additional search fees were accompanied by the applicant's protest.

No protest accompanied the payment of additional search fees.

FURTHER INFORMATION CONTINUED FROM PCT/ISA/ 210

This International Searching Authority found multiple (groups of) inventions in this international application, as follows:

1. Claims: 1-5,22-30

Obtaining a first survey data set from a vertical electric dipole (VED) in an electromagnetic survey and additionally:

- obtaining a second set of data from a VMD source

2. Claim : 6

Obtaining a first survey data set from a vertical electric dipole (VED) in an electromagnetic survey and additionally:

- obtaining a second set of data from naturally occurring magnetotelluric electromagnetic fields

3. Claims: 7-21,31-43

Method of planning or analysing an electromagnetic survey, comprising the steps:

- creating a model (normalisation data set)
- setting values for certain parameters (of this model)
- performing a simulation of the electromagnetic survey with VED (VMD or MT)

4. Claims: 44-52

A method of monitoring an area comprising the steps:

- waiting a period of time after obtaining the VED data set
- obtaining a second VED data set
- combining both data sets

INTERNATIONAL SEARCH REPORT

Information on patent family members

International Application No

PCT/GB 03/02379

Patent document cited in search report	Publication date	Patent family member(s)	Publication date
US 2002079899	A1	27-06-2002	US 6614229 B1 02-09-2003
			GB 2388432 A 12-11-2003
			DK 200100443 A 28-09-2001
			GB 2361547 A ,B 24-10-2001
			NL 1017664 A1 28-09-2001
			NO 20011530 A 28-09-2001
			US 2003209347 A1 13-11-2003
WO 0214906	A	21-02-2002	AU 7858001 A 25-02-2002
			BR 0113208 A 01-07-2003
			CA 2417832 A1 21-02-2002
			CN 1447924 T 08-10-2003
			EP 1309887 A1 14-05-2003
			WO 0214906 A1 21-02-2002
			NO 20020201 A 02-04-2002
US 3548299	A	15-12-1970	FR 1533337 A 19-07-1968
			FR 1546682 A 22-11-1968
			DE 1773563 A1 05-10-1972
			GB 1239953 A 21-07-1971
			JP 50021961 B 26-07-1975
			NL 6807964 A 09-12-1968
			SE 353154 B 22-01-1973
FR 1566338 A 09-05-1969			
US 5905657	A	18-05-1999	DE 69725468 D1 13-11-2003
			EP 0951652 A2 27-10-1999
			US 6256603 B1 03-07-2001
			WO 9827444 A2 25-06-1998
US 4679174	A	07-07-1987	CA 1226064 A1 25-08-1987
WO 9811455	A	19-03-1998	AU 735749 B2 12-07-2001
			AU 4267097 A 02-04-1998
			CN 1230260 A 29-09-1999
			EA 1212 B1 25-12-2000
			EP 0937267 A1 25-08-1999
			NO 991147 A 10-03-1999
			SE 515924 C2 29-10-2001
			SE 9900849 A 10-03-1999
			WO 9811455 A1 19-03-1998
			US 6438069 B1 20-08-2002