



US 20130134331A1

(19) **United States**

(12) **Patent Application Publication**

**Coyle et al.**

(10) **Pub. No.: US 2013/0134331 A1**

(43) **Pub. Date: May 30, 2013**

(54) **ION BEAM SAMPLE PREPARATION  
THERMAL MANAGEMENT APPARATUS  
AND METHODS**

**Publication Classification**

(51) **Int. Cl.**  
*G21F 3/00* (2006.01)  
(52) **U.S. Cl.**  
CPC ..... *G21F 3/00* (2013.01)  
USPC ..... **250/515.1**

(71) Applicant: **Gatan, Inc.**, Pleasanton, CA (US)  
(72) Inventors: **Steven Thomas Coyle**, Alameda, CA (US); **John Andrew Hunt**, Fremont, CA (US)

(57) **ABSTRACT**

Disclosed are embodiments of an ion beam shield for use in an ion beam sample preparation apparatus and methods for using the embodiments. The apparatus comprises an ion beam irradiating means in a vacuum chamber that may direct ions toward a sample, a shield blocking a portion of the ions directed toward the sample, and a shield retention stage with shield retention means that replaceably and removably holds the shield in a position. The ion beam shield has datum features which abut complementary datum features on the shield retention stage when the shield is held in the shield retention stage. The shield has features which enable the durable adhering of the sample to the shield for processing the sample with the ion beam. The complementary datum features on both shield and shield retention stage enable accurate and repeatable positioning of the sample in the apparatus for sample processing and reprocessing.

(73) Assignee: **GATAN, INC.**, Pleasanton, CA (US)

(21) Appl. No.: **13/730,962**

(22) Filed: **Dec. 29, 2012**

**Related U.S. Application Data**

(63) Continuation of application No. 13/082,364, filed on Apr. 7, 2011, now Pat. No. 8,384,050.

(60) Provisional application No. 61/322,870, filed on Apr. 11, 2010.

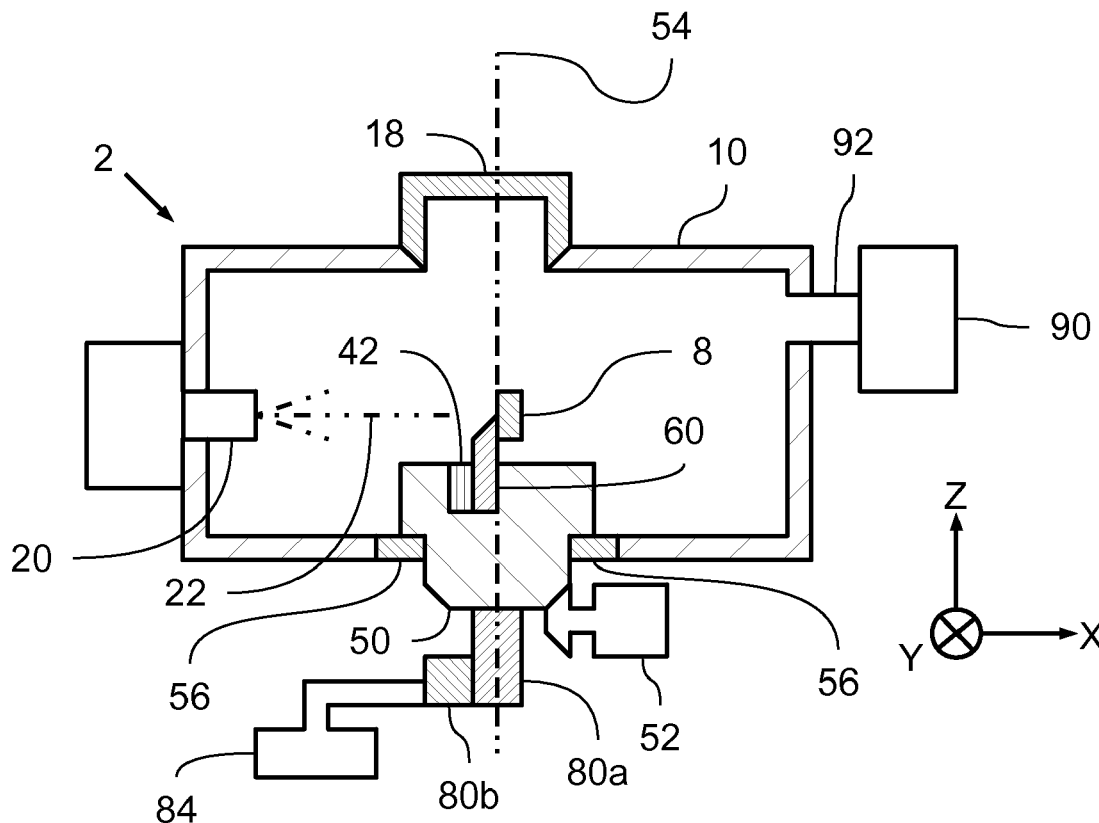

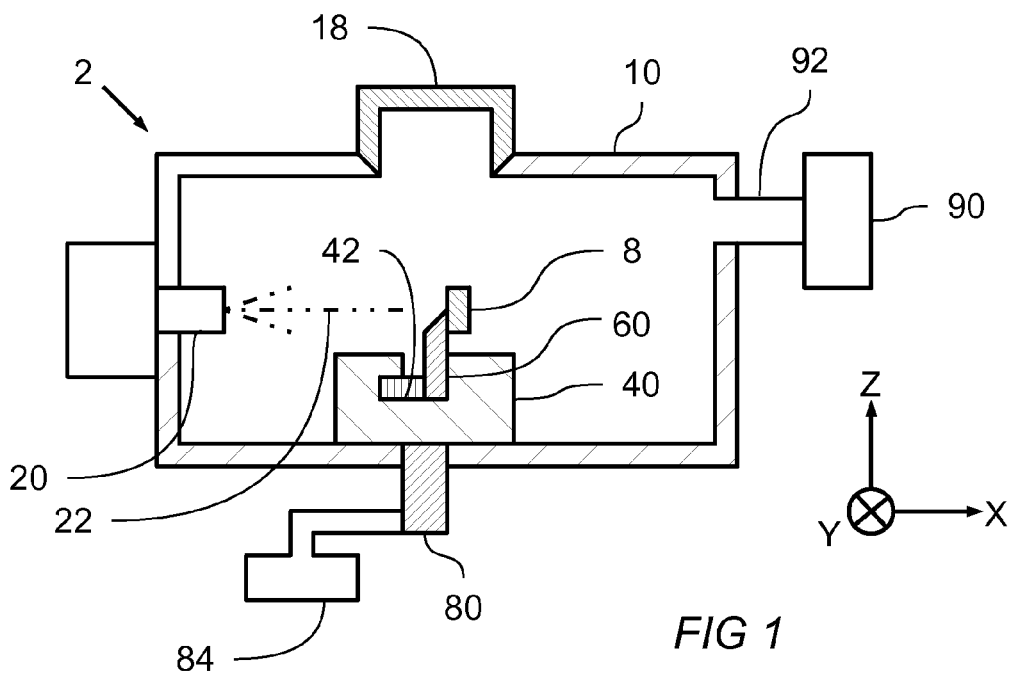

FIG 1

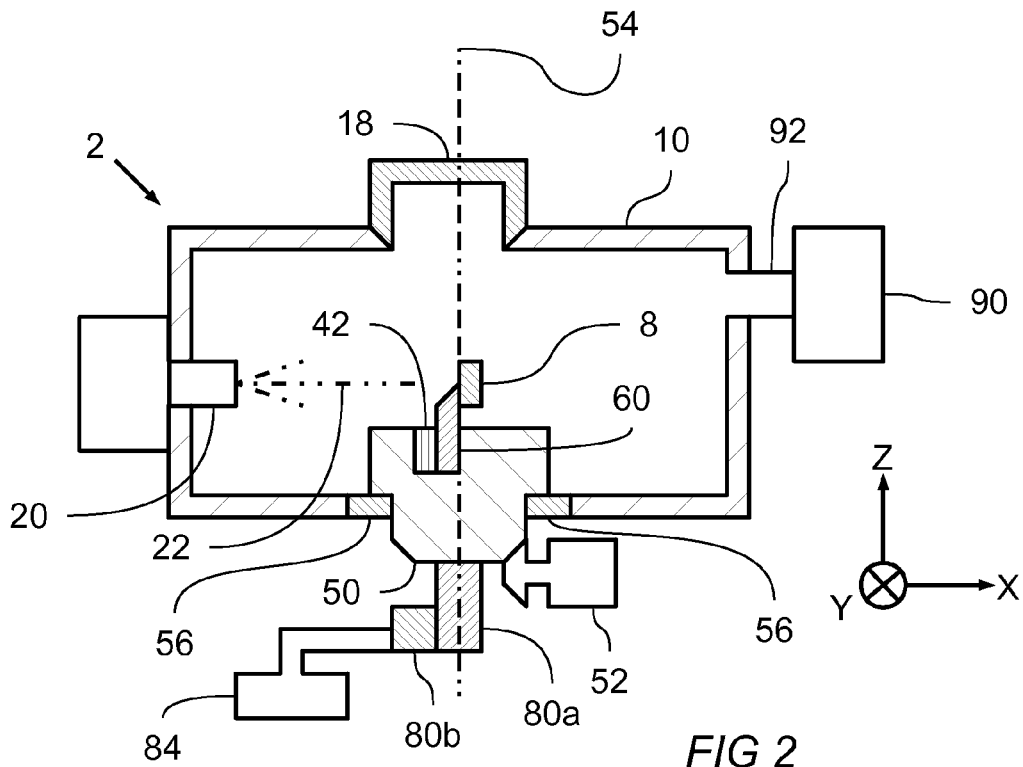
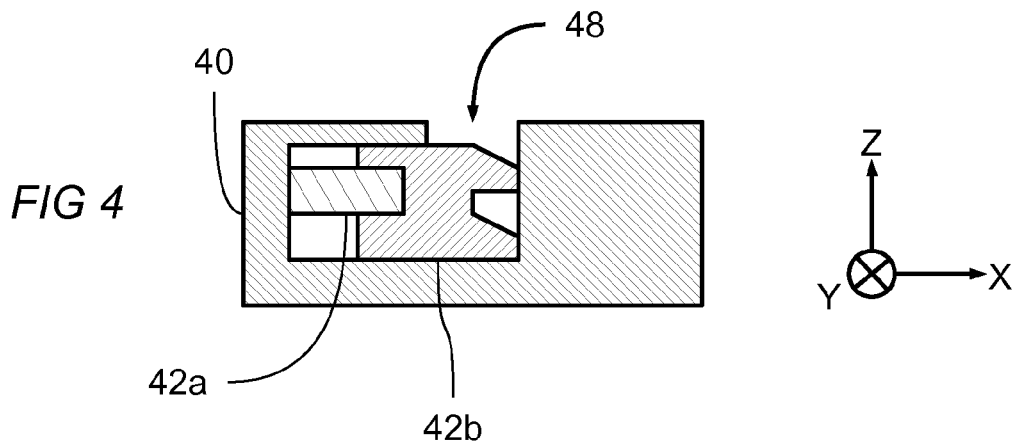
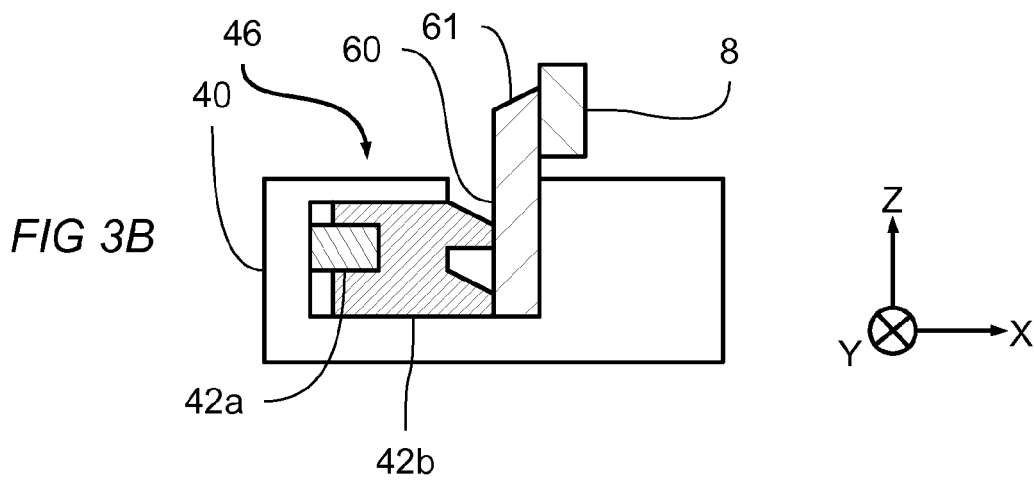
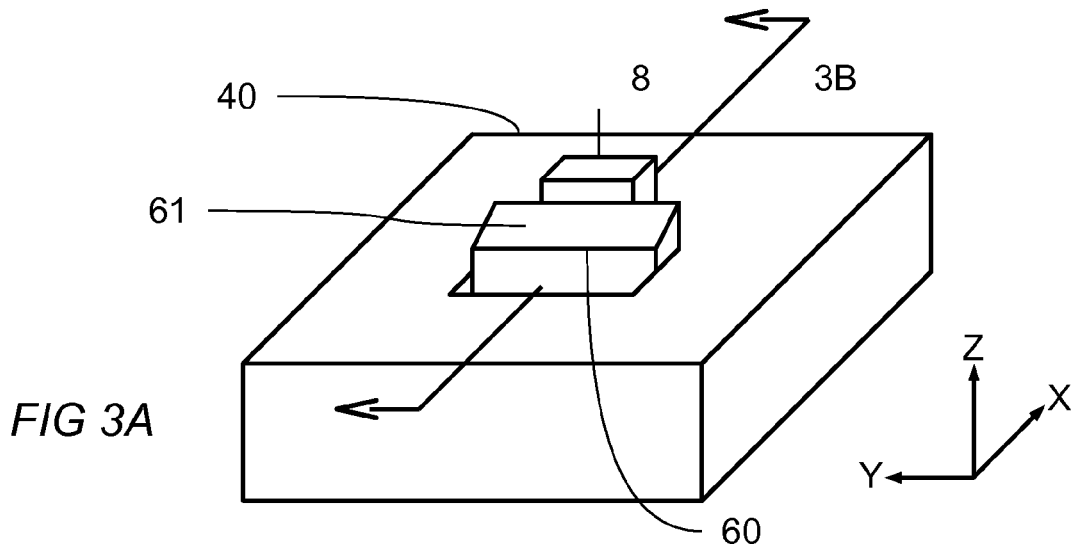

FIG 2



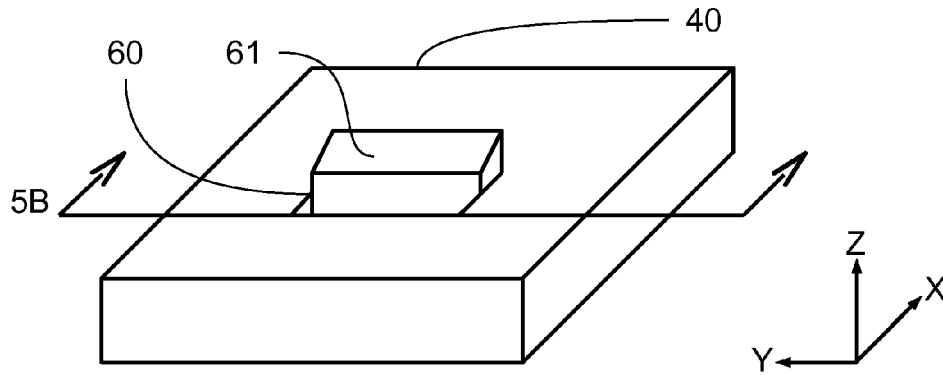

FIG 5A

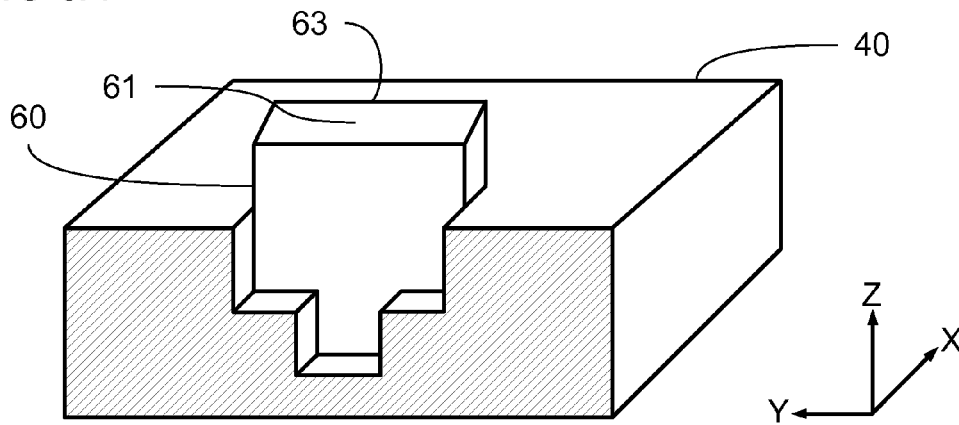

FIG 5B

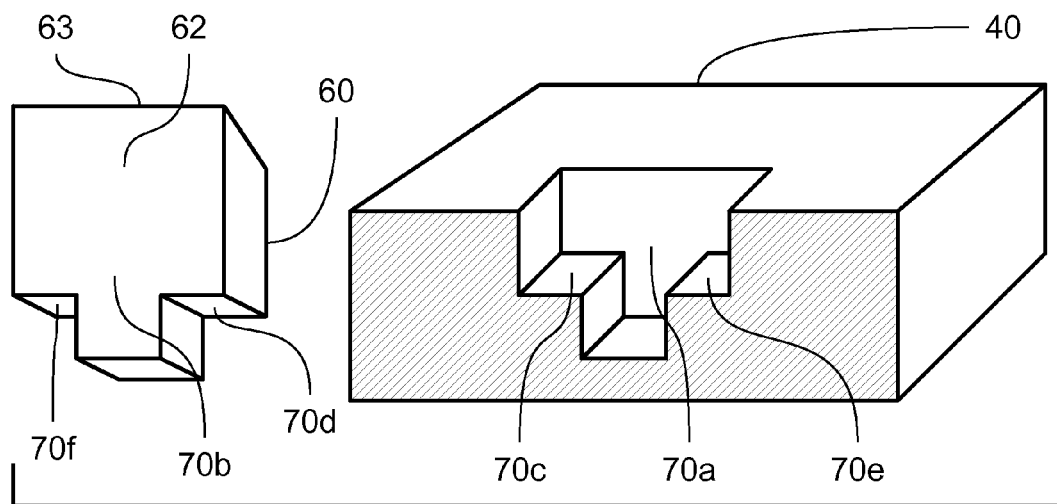

FIG 6

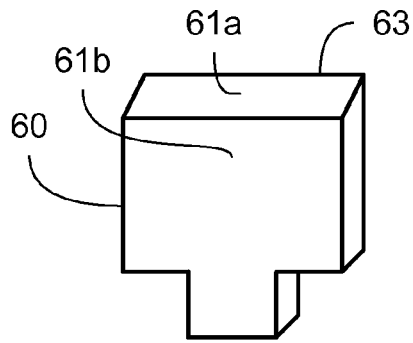

FIG 7A

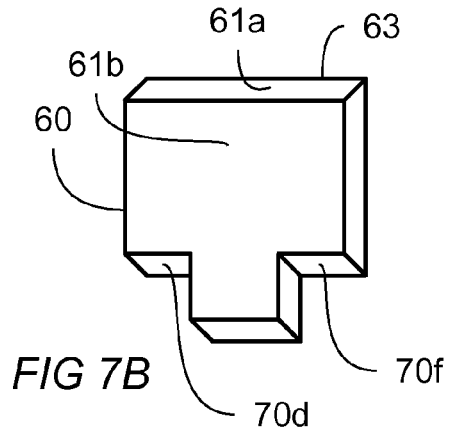

FIG 7B

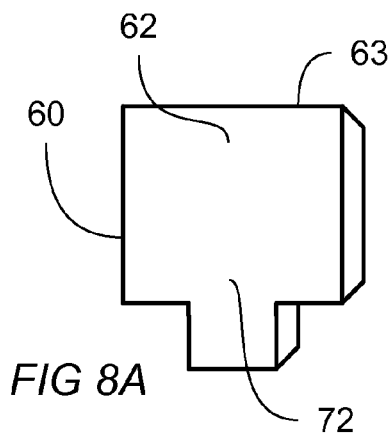

FIG 8A

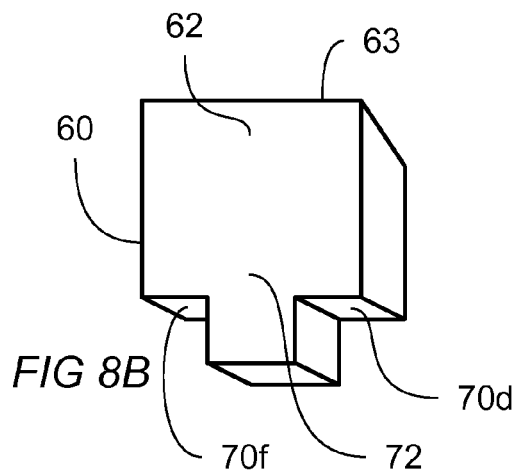

FIG 8B

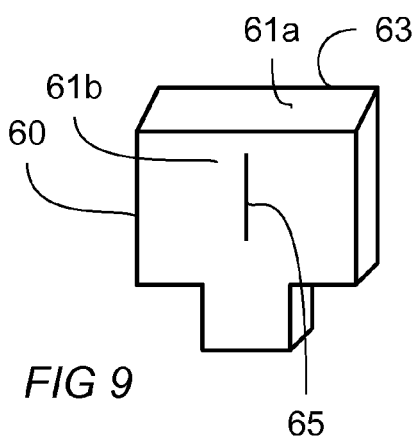

FIG 9

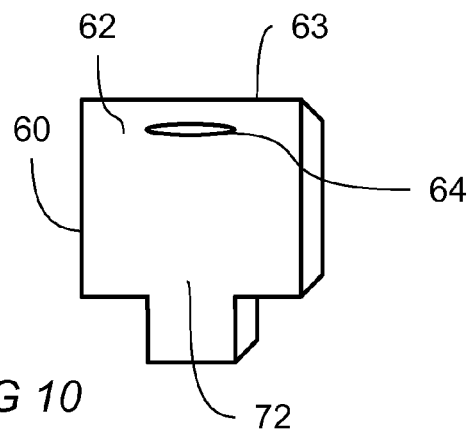

FIG 10

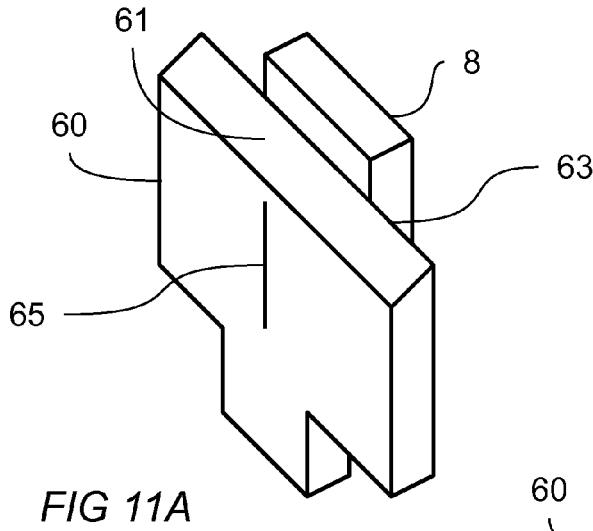

FIG 11A

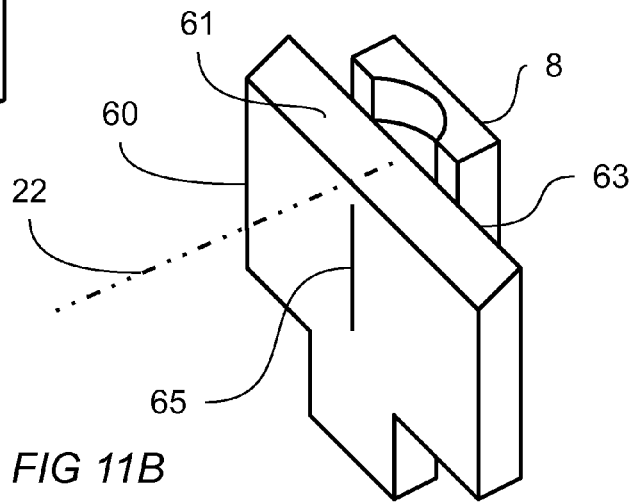

FIG 11B

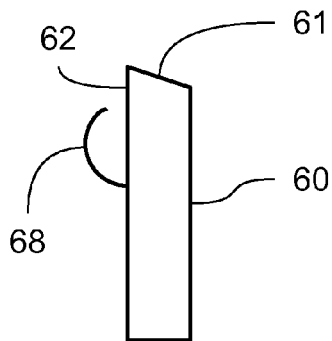

FIG 12A

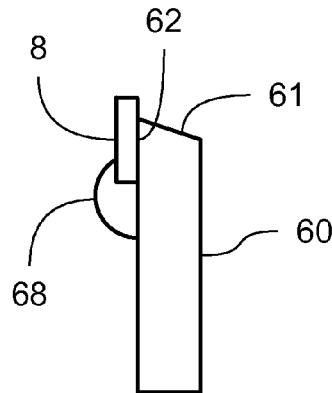

FIG 12B

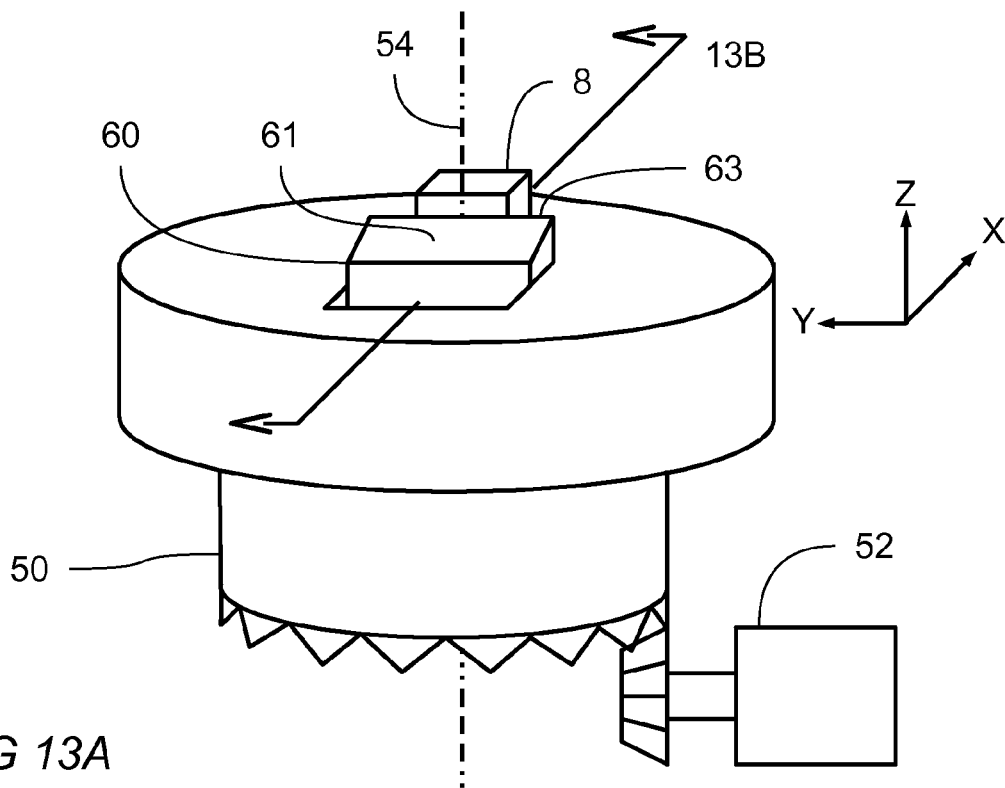

FIG 13A

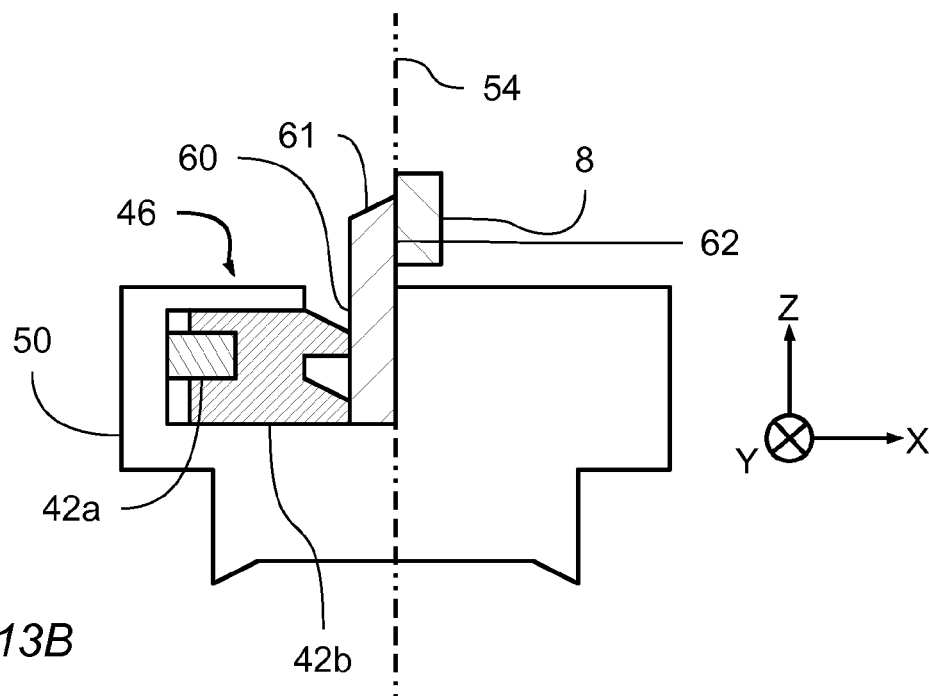

FIG 13B

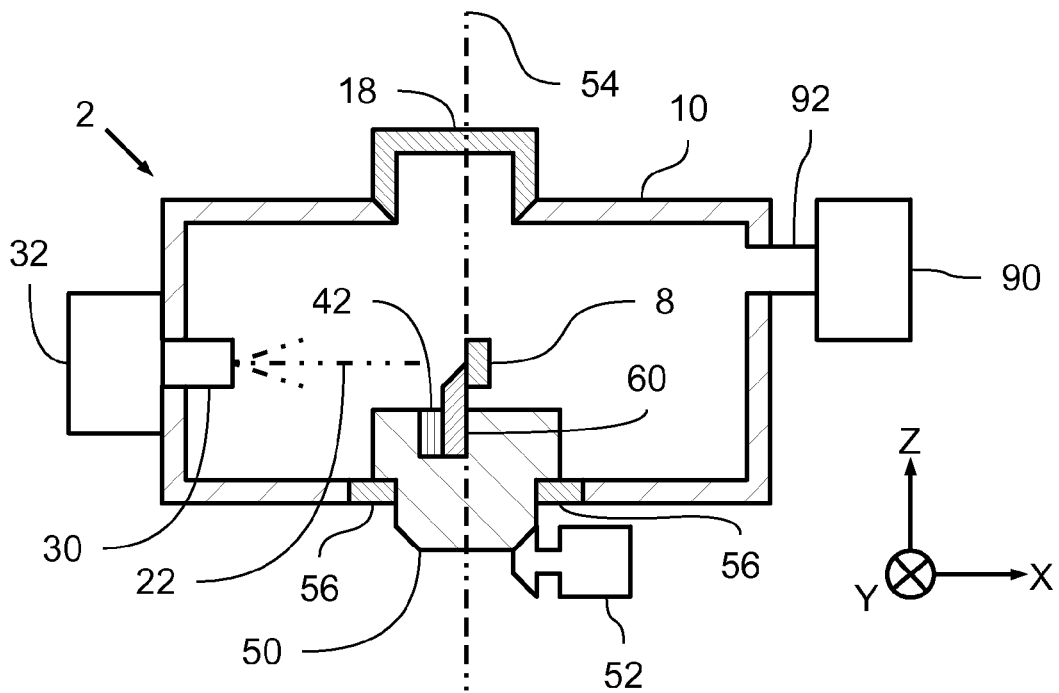

FIG 14



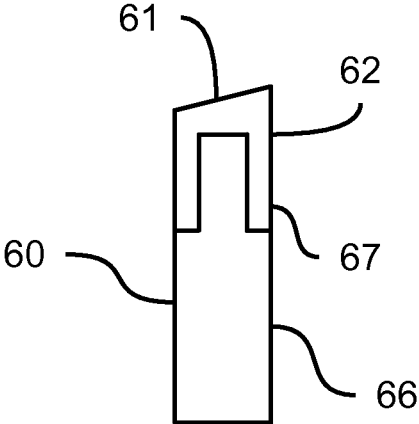

FIG 15A

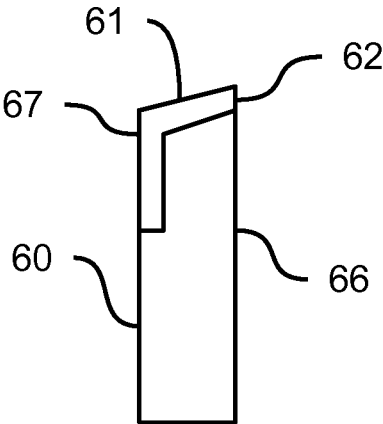

FIG 15B

## ION BEAM SAMPLE PREPARATION THERMAL MANAGEMENT APPARATUS AND METHODS

### CROSS REFERENCE TO RELATED APPLICATIONS

**[0001]** This application is a continuation of prior filed non-provisional application Ser. No. 13/082,364 filed Apr. 7, 2011. Non-provisional utility application Ser. No. 13/082,364 claims the benefit of prior filed provisional Application No. 61/322,870 filed Apr. 11, 2010. application Ser. No. 13/082,364 is incorporated herein by reference. Application No. 61/322,870 is incorporated herein by reference.

### STATEMENT REGARDING FEDERALLY SPONSORED RESEARCH OR DEVELOPMENT

**[0002]** Not Applicable.

### DESCRIPTION OF ATTACHED APPENDIX

**[0003]** Not Applicable.

### BACKGROUND

**[0004]** The present disclosure relates to the use of one or more ion beams to prepare materials for microscopic observation or spectroscopic analysis. Microscopic observational techniques include, but are not limited to, optical microscopy, scanning electron microscopy (SEM), transmission electron microscopy (TEM), scanning transmission electron microscopy (STEM), reflection electron microscopy (REM). Spectroscopic analysis techniques include, but are not limited to, x-ray micro-analysis, reflection electron energy-loss spectroscopy (REELS), electron back-scattered diffraction (EBSD), x-ray photoelectron spectroscopy (XPS), and Auger electron spectroscopy (AES). Materials to be viewed under any microscopic technique may require processing to produce a sample suitable for microscopic examination.

**[0005]** Ion beam milling of a material can produce samples that are well suited for microscopic examination. An ion beam irradiating device may generate, accelerate, and direct a beam of ions toward a sample. The impact of ions on the sample sputters material away from the area of ion impact. Furthermore the sample surface may be polished by the ion beam to a substantially smooth condition further enhancing observational properties of the sample. Regions of interest in the sample may be exposed and polished by the use of ion beams thus making a suitable observational sample from the material under investigation.

**[0006]** Broad Ion Beam Slope-Cutting (BIBSC), also known as cross-section cutting using broad ion beam sources or cross-section polishing using broad ion beam sources, is a rapid method for removing sample material to expose a smooth and substantially artifact-free cross-sectional surface for ultimate analysis by various microscopies and spectroscopies. A notable advantage of the BIBSC technique is high rates of surface preparation that can exceed tens or hundreds or thousands of square microns per hour, often over sample milling times of tens or hundreds of minutes.

**[0007]** Important considerations to users of the BIBSC technique include: reducing or minimizing the time and effort the user is occupied in processing the sample; reducing or minimizing the number of steps where delicate samples are directly handled and at risk for damage, such as during mounting to sample holders for processing or analysis; reduc-

ing or minimizing the time and effort the user is occupied transferring the sample into the ultimate analysis equipment (imaging or spectroscopy), and aligning the coordinates of the prepared sample region to the ultimate analysis equipment prior to analysis; ensuring high quality and high probability of success in processing and imaging the sample; reducing or minimizing the time that the BIBSC ion milling equipment and sample mounting equipment is occupied for each sample; and ensuring high-quality microscopy observation of the sample during sample mounting and ultimate analysis by reducing the working distance required between the sample and the objective or probe forming lens used for observation.

**[0008]** While a sample is being prepared in the ion beam it may experience heating. Heating may alter the sample in a ways that are undesirable. It may be the case, for example, that heating the sample softens or melts the sample thereby causing alterations in the sample that would not happen if the temperature were maintained in a desirable range. Embodiments of the present disclosure teach apparatus and methods of using that apparatus to manage the thermal environment of a sample while it is being prepared in the ion beam sample preparation apparatus.

**[0009]** In consideration of the foregoing points it is clear that embodiments of the present disclosure confer numerous advantages and are therefore highly desirable.

### SUMMARY

**[0010]** The present disclosure is directed to ion beam sample preparation thermal management apparatus and methods for using the disclosed apparatus to prepare samples for later observation. The apparatus has features to quickly and repeatably retain and release both unprepared samples and prepared samples thereby facilitating preparation of samples in the ion beam apparatus and also facilitating the observation of the prepared samples in an observation apparatus. Features of the disclosure enable accurate and repeatable positioning of the sample both within the ion beam sample preparation apparatus and also within observation apparatus later used for observing prepared samples. The thermal management features of the present disclosure work to manage the thermal environment of the sample being prepared. The temperature of the sample undergoing ion beam sample preparation may thereby be influenced by the thermal environment created by the apparatus.

**[0011]** An embodiment according to the present disclosure of an apparatus for ion beam sample preparation thermal management comprises: an ion beam irradiating means disposed in a vacuum chamber and directing an ion beam toward a sample; a shield retention stage disposed in the vacuum chamber; said shield retention stage comprising: a first datum feature; a second datum feature; a shield retention means having at least a shield releasing position and a shield retaining position; a first thermal transfer member in thermally conductive contact with said shield retention stage; a heat sink means configured to conduct heat away from said first thermal transfer member; a shield having at least a rigid planar portion, the shield removeably and replaceably held in said shield retention stage, said shield further comprising: a proximal sample surface; a first shielding surface disposed in the path of the ion beam and positioned to shield a portion of the ion beam directed at the sample when said shield is held in the shield retaining position of the shield retention means; a third datum feature formed integrally with said shield,

wherein said shield retention means in said shield retaining position urges said third datum feature to abut in thermally conductive contact said first datum feature; and, a fourth datum feature formed integrally with said shield, wherein said shield retention means in said shield retaining position urges said fourth datum feature to abut said second datum feature.

**[0012]** In a related embodiment of the ion beam sample preparation thermal management apparatus, the shield retention stage further comprises a fifth datum feature, and the shield further comprises a sixth datum feature formed integrally with the shield, wherein the shield retention means in said shield retaining position urges said sixth datum feature to abut said fifth datum feature.

**[0013]** In a related embodiment of the ion beam sample preparation thermal management apparatus first shielding surface meets said proximal sample surface at an angle of less than about 90 degrees and more than about 80 degrees.

**[0014]** In a related embodiment of the ion beam sample preparation thermal management apparatus the first shielding surface meets said proximal sample surface at an angle of less than about 87 degrees and more than about 83 degrees.

**[0015]** In a related embodiment of the ion beam sample preparation thermal management apparatus the first shielding surface is made of non-magnetic material with low sputtering yield.

**[0016]** In a related embodiment of the ion beam sample preparation thermal management apparatus at least a portion of the first shielding surface is made of tantalum or titanium.

**[0017]** In a related embodiment of the ion beam sample preparation thermal management apparatus the third datum feature is a datum surface and at least a portion of said datum surface is coextensive with at least a portion of said proximal sample surface.

**[0018]** In a related embodiment of the ion beam sample preparation thermal management apparatus the proximal sample surface has at least one recessed portion configured for the flowing of adhesive between the shield and the sample.

**[0019]** In a related embodiment of the ion beam sample preparation thermal management apparatus the shield further comprises a sample clamping means coupled to the shield and configured to hold the sample against said proximal sample surface.

**[0020]** In a related embodiment of the ion beam sample preparation thermal management apparatus the shield further comprises: a second shielding surface having a portion disposed in the path of a portion of the ion beam; a shield edge formed where the first shielding surface meets the proximal sample surface; and, a visible alignment mark on the second shielding surface, configured such that the location of said visible alignment mark is in a predetermined relationship to the region where the ion beam impinges on said shield edge when said shield is held in the shield retaining position of the shield retention means.

**[0021]** In a related embodiment of the ion beam sample preparation thermal management apparatus the heat sink means is configured to use nitrogen to conduct heat away from the first thermal transfer member.

**[0022]** In a related embodiment of the ion beam sample preparation thermal management apparatus the shield is made of a cladding material joined to a core material such that a portion of the cladding material forms at least a portion of the first shielding surface, and a portion of the core material

forms the third and fourth datum features of the shield. In a related embodiment, the core material of the shield comprises copper.

**[0023]** Another embodiment of the present disclosure is directed to an apparatus for ion beam sample preparation thermal management according to an embodiment of the present disclosure comprises: an ion beam irradiating means disposed in a vacuum chamber and directing an ion beam toward a sample; a rotating shield retention stage disposed in the vacuum chamber; said shield retention stage comprising: a first datum feature; a second datum feature; a shield retention means having at least a shield releasing position and a shield retaining position; a rotation axis located substantially in the plane of the first datum feature; a rotation drive configured to rotate the rotating shield retention stage around the rotation axis; a first thermal transfer member rotating with the sample retention stage and in thermally conductive contact with the sample retention stage; a second thermal transfer member in thermally conductive contact with said first thermal transfer member; a heat sink means configured to conduct heat away from said second thermal transfer member; a shield having at least a rigid planar portion, removeably and replaceably held in said shield retention stage, said shield further comprising: a third datum feature formed integrally with the shield, wherein said shield retention means in said shield retaining position urges said third datum feature to abut in thermally conductive contact said first datum feature; a fourth datum feature formed integrally with the shield, wherein said shield retention means in said shield retaining position urges said fourth datum feature to abut said second datum feature; a first shielding surface disposed in the path of the ion beam and positioned to shield a portion of the ion beam directed at the sample when said shield is held in the shield retaining position of the shield retention means; a proximal sample surface; a shield edge formed where the first shielding surface meets the proximal sample surface, wherein said shield edge is held substantially perpendicular to said rotation axis when said shield is held in the shield retaining position of the shield retention means.

**[0024]** Another embodiment of the present disclosure is directed to an ion beam sample preparation thermal management apparatus comprising: a modulating ion beam irradiating means disposed in a vacuum chamber and directing an ion beam toward a sample, said modulating ion beam irradiating means operatively coupled to a modulation drive wherein the modulation drive is configured to operate the modulating ion beam irradiating means at at least two different ion beam intensities; a shield retention stage disposed in the vacuum chamber; said shield retention stage comprising: a first datum feature; a second datum feature; a shield retention means having at least a shield releasing position and a shield retaining position; a shield having at least a rigid planar portion, the shield removeably and replaceably held in said shield retention stage, said shield further comprising: a proximal sample surface; a first shielding surface disposed in the path of the ion beam and positioned to shield a portion of the ion beam directed at the sample when said shield is held in the shield retaining position of the shield retention means; a third datum feature formed integrally with said shield, wherein said shield retention means in said shield retaining position urges said third datum feature to abut said first datum feature; and a fourth datum feature formed integrally with said shield,

wherein said shield retention means in said shield retaining position urges said fourth datum feature to abut said second datum feature.

[0025] Another embodiment of the present disclosure is directed to an ion beam sample preparation thermal management apparatus comprising: an ion beam irradiating device disposed in a vacuum chamber and directing an ion beam toward a sample, the ion beam irradiating device comprising an ion beam modulation means providing at least a first ion beam intensity and a second ion beam intensity, wherein the first ion beam intensity is lower in intensity than the second ion beam intensity; a rotating shield retention stage disposed in the vacuum chamber comprising: a shield retention means having at least a shield retaining position and a shield releasing position; a rotation axis; a rotation drive for rotating the rotating shield retention stage around the rotation axis; a shield removably and replaceably held in said rotating shield retention stage, said shield comprising: a shielding surface, wherein in said shield retaining position at least a portion of the shielding surface is disposed in the path of the ion beam and positioned to shield at least a portion of the ion beam directed at the sample for at least a portion of a rotation of said rotating shield retention stage; a proximal sample surface for durably adhering the sample to the shield.

#### BRIEF DESCRIPTION OF THE DRAWINGS

[0026] These and other features, aspects, and advantages of the present invention will become better understood with regard to the following description, appended claims, and accompanying drawings where:

[0027] FIG. 1 shows a schematic cross sectional view of an ion beam sample preparation thermal management apparatus according to an embodiment of the present disclosure.

[0028] FIG. 2 shows a schematic cross sectional view of an ion beam sample preparation thermal management apparatus comprising a modulating ion beam irradiating means and a modulation drive according to another embodiment of the present disclosure.

[0029] FIG. 3A shows a perspective view of a shield retention stage retaining a shield with a sample durably adhered to the shield. The figure also shows the cross section plane used for FIG. 3B.

[0030] FIG. 3B shows a cross sectional view of the shield retention stage of FIG. 3A with shield retention means in a shield retaining position.

[0031] FIG. 4 shows a cross section similar to that of FIG. 3B, except that FIG. 4 shows the cross section with the shield retention means in a shield releasing position.

[0032] FIG. 5A shows a perspective view of another shield retention stage according to the present disclosure indicating a cross sectional plane for FIG. 5B.

[0033] FIG. 5B shows a perspective sectional view of the shield retention stage of FIG. 5A with the shield positioned in the shield retaining position.

[0034] FIG. 6 shows an exploded perspective section view of the shield and shield retention stage of FIG. 5B. Datum features of both the shield and the shield retention stage are made visible in this view.

[0035] FIGS. 7A and 7B show perspective views of a shield according to embodiments of the present disclosure viewed from the ion beam side of the shield.

[0036] FIGS. 8A and 8B show perspective views of a shield according to embodiments of the present disclosure viewed from the proximal sample side of the shield.

[0037] FIG. 9 shows a perspective view of another shield according to the present disclosure viewed from the ion beam side of the shield and having a visible alignment feature

[0038] FIG. 10 shows a perspective view of another shield according to the present disclosure viewed from the proximal sample side of the shield and having a recessed portion to facilitate the flow of adhesive under the sample.

[0039] FIGS. 11A and 11B show perspective views of a shield with a durably adhered sample both before (FIG. 11A) and after (FIG. 11B) preparation in an ion beam sample preparation thermal management apparatus according to the present disclosure.

[0040] FIGS. 12A and 12B show an embodiment of a shield with integrated sample clamping means according to an embodiment of the present disclosure.

[0041] FIG. 13A shows a schematic perspective view of a rotating shield retention stage and rotation drive according to embodiments of the present disclosure.

[0042] FIG. 13B shows a cross sectional view of the rotating shield retention stage of FIG. 13A with shield retention means in a shield retaining position.

[0043] FIG. 14 shows a schematic cross sectional view of an ion beam sample preparation thermal management apparatus according to an embodiment of the disclosure.

[0044] FIGS. 15A and FIG. 15B show schematic views of embodiments of a shield comprising core material and cladding material.

#### LIST OF REFERENCE NUMBERS APPEARING IN THE FIGURES

- [0045] 2—ion beam sample preparation thermal management apparatus
- [0046] 8—sample
- [0047] 10—vacuum chamber
- [0048] 18—chamber cover
- [0049] 20—ion beam irradiating means
- [0050] 22—central ion beam axis
- [0051] 30—modulating ion beam irradiating means
- [0052] 32—modulation drive
- [0053] 40—shield retention stage
- [0054] 42—shield retention means
- [0055] 42a—shield retention means first member
- [0056] 42b—shield retention means second member
- [0057] 46—shield retaining position
- [0058] 48—shield releasing position
- [0059] 50—rotating shield retention stage
- [0060] 52—rotation drive
- [0061] 54—rotation axis
- [0062] 56—vacuum seal
- [0063] 60—shield
- [0064] 61—shielding surface
- [0065] 61a, 61b, etc.—first shielding surface, second shielding surface, etc.
- [0066] 62—proximal sample surface
- [0067] 63—shield edge
- [0068] 64—recessed portion
- [0069] 65—visible alignment mark
- [0070] 66—core material
- [0071] 67—cladding material
- [0072] 68—sample clamping means
- [0073] 70a, 70b, 70c, 70d, 70e, 70f—first datum feature, second datum feature, third datum feature, fourth datum feature, fifth datum feature, sixth datum feature.
- [0074] 72—datum surface

- [0075] 80—thermal transfer member
- [0076] 80a, 80b, etc—first thermal transfer member, second thermal transfer member, etc.
- [0077] 84—heat sink means
- [0078] 90—vacuum pump means
- [0079] 92—pumping manifold

#### Description

[0080] The Broad Ion Beam Slope-Cutting (BIBSC) sample preparation procedure can be described as a series of process steps, p1-p5:

- [0081] p1) Aligning the desired region of the sample to be processed to a usable portion of an ion shield;
- [0082] p2) Aligning the sample and shield in the BIBSC ion-milling system such that the desired region of the sample can be processed by the ion beam or beams;
- [0083] p3) Evacuating the ion-milling system to vacuum levels appropriate for ion beam milling;
- [0084] p4) Performing the ion-milling operation or operations, sometimes using a process monitoring step such as in situ light-microscopy imaging to verify sufficient cut depth and quality of the cross section;
- [0085] p5) Venting of the BIBSC ion-milling equipment and removal of the sample from the equipment.

[0086] The analysis of prepared BIBSC sample can be described as a series of process steps, p6-p9:

- [0087] p6) Introduction of the sample to the ultimate analysis microscope and initializing the microscope so that analysis can commence;
- [0088] p7) Finding the location of the prepared cross-sectional surface by adjusting any number of the microscope's translation stages, tilt stages, and rotation stages so that the desired area can be imaged;
- [0089] p8) Performing the desired microscopic or spectroscopic analyses;
- [0090] p9) Removing the sample from the microscope;
- [0091] p10) After analyzing the sample, a decision may be made to reprocess the sample to change the cut depth, position, or angle—traditionally requiring a repeat of p1-p9.

[0092] Embodiments of the present disclosure uniquely permit certain efficiencies and capabilities in the processing and subsequent observation and analysis of BIBSC produced samples. Beneficial features, functions, and aspects of the present disclosure include, but are not limited to:

- [0093] 1. Datum features on the shield, shield retention device in the sample-to-shield mounting apparatus, shield retention device in the BIBSC ion-mill, shield retention device in the ultimate analysis equipment allow significant time efficiencies in processing steps p1, p2 and p7;
- [0094] 2. The integral nature of the sample durably adhered to the shield, and to a lesser extent with the sample merely clamped to the shield, allows greater certainty in ensuring alignment of the shield to the sample remains consistent during p4 even over long time-scales and changes in temperature, whereas quality of the cross section cutting process is reduced if this precision alignment is not maintained;
- [0095] 3. The integral nature of the sample durably adhered to the shield in processing step p1 eliminates the requirement for expensive and sizable fixturing apparatus to maintain their spatial relationship together throughout the milling operation, and enables multiple

samples to be prepared in advance of milling without multiple fixturing apparatus;

- [0096] 4. The integral nature of the sample durably adhered or clamped to the shield eliminates the requirement for dismantling the sample from the shield prior to observation in a microscope, even in cases where the smallest working distances between imaging objective and sample are employed. This permits reduction of both time and risk of damage to the sample during sample remounting in processing step p6;
- [0097] 5. In the case where reprocessing the sample as in step p10 is performed, the integral nature of the sample durably adhered or clamped to the shield can eliminate the need for steps p1 and p2 entirely, which significantly reduces processing time and risk of damage to the sample during sample remounting; and,
- [0098] 6. In the case where reprocessing the sample as in step p10 is performed, the integral nature of the sample durably adhered or clamped to the shield allows different cross-sectional planes to be cut very close to the originally cut cross-sectional plane by varying the angle of ion beam impinging on the sample and shield.
- [0099] Turning now to FIG. 1, illustrated is a schematic cross sectional view of an embodiment of an ion beam sample preparation thermal management apparatus 2 configured to control the temperature of sample 8 while the sample is being prepared in the ion beam. The embodiment of FIG. 1 is shown comprising: a vacuum chamber 10 in which a sample 8 is prepared; chamber cover 18 which seals vacuum chamber 10 from the outside atmosphere; vacuum pump means 90 and pumping manifold 92 which together bring vacuum chamber 10 to vacuum levels appropriate for ion beam milling; ion beam irradiating means 20 which creates and directs an ion beam having a central ion beam axis 22 toward sample 8; a shield 60 which shields at least a portion of sample 8 from at least a portion of the ion beam; a shield retention stage 40 which holds and accurately positions shield 60 with respect to the direction and extent of the ion beam; a shield retention means 42 which both retains shield 60 in shield retention stage 40 and also urges shield 60 to remain in a position whereby the ion beam may prepare sample 8, shield retention means 42 also urging thermally conductive contact between shield 60 and shield retention stage 40; a thermal transfer member 80 which is in thermally conductive contact with shield retention stage 40; and a heat sink means 84 which conducts heat away from thermal transfer member 80.
- [0100] With continuing reference to FIG. 1, the ion beam preferably comprises noble gas ions. Elements used for the ion beam may include but are not limited to: Argon, Xenon, and Krypton. The ion beam may also comprise a mixture of ions and neutrals. Shield retention stage 40 is disposed in vacuum chamber 10 in a predetermined position and orientation with respect to central ion beam axis 22. Heat sink means 84 may use gaseous nitrogen or liquid nitrogen as a heat absorbing medium. Heat sink means 84 may additionally comprise temperature control means capable of substantially maintaining thermal transfer member 80 at a predetermined temperature. After the sample has been prepared in the ion beam chamber, chamber cover 18 may be removed; then the shield and sample may be removed for observation in a microscope.
- [0101] In a preferred embodiment of shield 60, a material with good thermal conductivity may be used to improve thermal transfer between shield and the shield retention stage,

said material including but not limited to a substantially non-magnetic metal. In another preferred embodiment of shield 60, a material with good thermal conductivity can be used as a core material 66 to improve thermal transfer between shield and the shield retention stage, and a substantially non-magnetic material with low sputtering yield may be used as a cladding material 67 over the core material whereby the cladding material forms at least part of the shielding surface 61 of shield 60. Figures FIG. 15A and FIG. 15B illustrate two different embodiments of shield 60, wherein each embodiment is shown comprising a combination of core material 66 and cladding material 67.

[0102] FIG. 3A shows a perspective view of shield retention stage 40 on which sample 8 has been durably adhered to shield 60 prior to placing the shield and sample combination in a shield retaining position 46 in shield retention stage 40. Shield 60 has a shielding surface 61 which is positioned in relation to sample 8 to shield at least a portion of said sample 8 from at least a portion of the ion beam. Also shown in FIG. 3A is a section line indicating the section view shown in FIG. 3B.

[0103] FIG. 3B shows a section view illustrating the position and function of the shield retention means which is part of shield retention stage 40. FIG. 3B shows an embodiment of the shield retention means comprising a shield retention means first member 42a and a shield retention means second member 42b. Shield retention means first member 42a urges shield retention means second member 42b against shield 60. The action of shield retention means first member also urges shield 60 against shield retention stage 40 and thereby maintains the position of shield 60 within shield retention stage 40 while the sample is prepared by ion beam. An embodiment of the shield retention means may comprise a spring for shield retention means first member 42a and a solid member as shield retention means second member 42b configured to slide within a cavity in shield retention stage 40.

[0104] FIG. 4 shows a view from the same sectional plane as in FIG. 3B, however in FIG. 4 the shield and sample have been removed to show a shield releasing position 48 of shield retention means. By means of the two positions provided by shield retention means, namely shield retaining position 46 as shown in FIG. 3A and FIG. 3B, and shield releasing position 48 as shown in FIG. 4, a shield may be removably and replaceably secured in shield retention stage 40. A sample that has been durably adhered to shield 60 may be processed, removed, and then reprocessed by simply placing it in the shield retaining position and preparing the sample again in the ion beam.

[0105] FIG. 5A shows a perspective view of shield retention stage 40 on which shield 60 is retained, wherein said shield has a shielding surface 61. FIG. 5A also shows a sectional plane used for FIG. 5B.

[0106] FIG. 5B shows a sectional perspective view illustrating physical features of both shield 60 and shield retention stage 40 that facilitate accurate and repeatable positioning of the shield with respect to the shield retention stage. The positioning of shield 60 assures that shielding surface 61 and shield edge 63 are accurately positioned and accurately oriented with respect to the shield retention stage and are positioned with respect to central ion beam axis 22 to intercept at least a portion of the ion beam directed toward the sample.

[0107] FIG. 6 shows a sectional perspective view as in FIG. 5B in which preferred embodiments of both shield 60 and shield retention stage 40 have a plurality of datum features

70a, 70b, 70c, 70d, 70e, and 70f. In the exploded view shown in FIG. 6, shield 60 has been removed from shield retention stage 40 and the shield is turned to expose a proximal sample surface 62 upon which a sample may be durably adhered prior to sample preparation by the ion beam. The plurality of datum features 70a, 70b, 70c, 70d, 70e, and 70f is provided on both shield 60 and shield retention stage 40 and they enable accurate and repeatable positioning of the shield 60 with respect to the shield retention stage 40. Datum features 70b, 70d, and 70f on the shield are shaped and positioned such that when they are caused to abut complementary datum features 70a, 70c, and 70e on the shield retention stage the shield may be held in a predetermined position and a predetermined orientation with respect to the central ion beam axis 22. Shield retention means 42 assures that datum features 70b, 70d, and 70f of shield 60 abut the corresponding datum features 70a, 70c, and 70e of the shield retention stage 40 when the shield is held in the shield retaining position. Shield edge 63, also visible in FIG. 6, is also caused to be in a predetermined position and predetermined orientation when the shield is held in the shield retaining position.

[0108] Datum features are arranged in pairs such that a datum feature on the shield has a corresponding datum feature on the shield retention stage. In FIG. 6 one such pair of datum features is datum feature 70a on the shield retention stage and datum feature 70b on the shield. Another pair of datum features shown in FIG. 6 is datum feature 70c on the shield retention stage and datum feature 70d on the shield. Another pair of datum features shown in FIG. 6 is datum feature 70e on the shield retention stage and datum feature 70f on the shield. When the shield is in the shield retaining position the shield retention means acts to urge the pairs of datum features to abut, thereby constraining the position of the shield with respect to the position of the shield retention stage. Datum features may be datum surfaces, as is shown in the preferred embodiment of FIG. 6, or they may be datum edges or datum vertices, or combinations of datum surfaces, datum edges, and datum vertices.

[0109] Turning now to figures FIG. 7A, FIG. 7B, FIG. 8A, FIG. 8B, FIG. 9, and FIG. 10, shown are various features and embodiments of shield 60 according to the present disclosure.

[0110] FIG. 7A is a perspective view of a shield showing a first shielding surface 61a, a second shielding surface 61b, and shield edge 63. Ions from the ion beam irradiating means that are blocked by the shield, and in particular the ions that are blocked by first shielding surface 61a are prevented from milling the sample. Ions not blocked by the shield may be used to prepare the sample for observation and analysis. When the ion beam is operating ions may or may not impact second shielding surface 61b. Whether ions do impact second shielding surface 61b depends on a number of factors including, but not limited to: the size of the ion beam; the angle at which the ion beam is directed; and, the position at which the ion beam is directed. It is a preferred embodiment of the shield that second shielding surface 61b be made of the same material as first shielding surface 61a. In preferred embodiments shield 60 is a generally planar rigid member, having one or more shielding surfaces that are smooth and may be polished, having a datum surface and at least an additional datum feature for facilitating accurate placement within the shield retention stage. Preferred materials for the shield are non-magnetic metals with low sputter yield including but not limited to tantalum or titanium. Lower cost embodiments of shield 60 may comprise core material 66 for the majority of

the shield and cladding material **67** used for the shielding surfaces. Preferred core materials include but are not limited to tantalum or titanium. Figures FIG. **15A** and FIG. **15B** illustrate two different embodiments of a shield **60**, wherein each embodiment is shown comprising a combination of core material **66** and cladding material **67**.

[0111] FIG. **7B** shows the same shield as shown in FIG. **7A** but from a different angle thereby illustrating the position and nature of a plurality of datum features **70d** and **70f**.

[0112] FIG. **8A** shows the same shield as shown in FIG. **7A** and FIG. **7B**. FIG. **8A** shows a perspective view of shield **60** from the side of the shield closest to the sample during ion beam sample preparation. Proximal sample surface **62** may be used to adhere the sample material to be prepared in the apparatus. Datum surface **72** is a datum feature that is a surface. In a preferred embodiment at least a portion of proximal sample surface **62** may be coextensive with at least a portion of datum surface **72**. Shield edge **63** is formed by the intersection of first shielding surface **61a** and proximal sample surface **62**. The angle between first shielding surface **61a** and proximal sample surface **62** has an impact on the quality of the milling performed on the sample by the ion beam. A preferred embodiment is achieved when said first shielding surface **61a** meets said proximal sample surface **62** at an angle of less than about 90 degrees and more than about 80 degrees. An even more preferred embodiment is achieved when said first shielding surface **61a** meets said proximal sample surface **62** at an angle of less than about 87 degrees and more than about 83 degrees.

[0113] FIG. **8B** shows the same shield as shown in FIG. **8A** but from a different angle thereby illustrating the position and nature of a plurality of datum features **70d** and **70f**, and datum surface **72**, present on shield **60**.

[0114] FIG. **9** shows a perspective view of shield **60** having first shielding surface **61a**, second shielding surface **61b**, shield edge **63**, and additionally comprising a visible alignment mark **65**. When the shield is held in the shield retaining position the visible alignment mark is positioned so that it indicates the approximate location where a portion of the ion beam will pass over shield edge **63** and impact the sample when the shield edge is substantially perpendicular to the central ion beam axis.

[0115] FIG. **10** shows a perspective view of shield **60** from the side of the shield closest to the sample during ion beam sample preparation. Proximal sample surface **62** may be used to adhere the sample material to the shield prior to ion beam sample preparation in the apparatus. Recessed portion **64** provides a recessed portion of proximal sample surface **62** useful for flowing adhesive under the sample thereby facilitating the durable adhering of sample to shield. Preferred materials used to adhere the sample to the shield include but are not limited to: UV cured glue, light cured glue, superglue, silver paint, and wax.

[0116] Turning now to FIG. **11A**, shown is a perspective view of shield **60**, shielding surface **61**, sample **8** durably adhered to the shield, and visible alignment mark **65**. FIG. **11A** depicts the sample prior to ion beam preparation. FIG. **11B** is a perspective view of the same objects depicted in FIG. **11A**, however, FIG. **11B** represents the sample after ion beam sample preparation. Shielding surface **61** intercepts a portion of the ion beam, which travels along central ion beam axis **22**. A portion of sample **8** is sputtered away by the ion beam during sample preparation thereby exposing a portion of the

sample lying in the plane defined by shield edge **63** and central ion beam axis **22**. A sample prepared in this way will be suitable for observation or analysis with a variety of microscopic or spectroscopic techniques, particularly those requiring a highly polished planar surface.

[0117] FIG. **12A** and **12B** illustrate another embodiment of shield **60** in which a sample clamping means **68** is formed integrally with the shield on the proximal sample surface **62**. FIG. **12A** depicts this shield prior to clamping a sample while FIG. **12B** depicts this shield after sample **8** has been secured to the shield by means of sample clamping means **68**. In another embodiment, sample clamping means **68** may be formed separately and then coupled to the shield prior to clamping the sample. Adhesive may be applied between the sample clamping means and the sample to further ensure the sample does not move with respect to the shield.

[0118] Use of the apparatus shown in FIG. **1** may proceed with reference to the following steps: outside of the vacuum chamber, a sample may be durably adhered to a shield; with the chamber cover removed, the sample and shield combination may be set in the shield retaining position of the shield retention stage; the chamber cover may then be replaced; with the chamber cover in place on the the vacuum chamber the vacuum pump means may be operated to evacuate the vacuum chamber through the pumping manifold thereby obtaining vacuum levels appropriate for ion beam milling; the ion beam irradiating means may then be operated to prepare the sample. When the sample is prepared to the extent desired by the user of the apparatus the ion beam irradiating means may be turned off, the vacuum chamber may be returned to atmospheric conditions, the chamber cover may be removed, and the prepared sample may be removed from the apparatus along with the shield to which it was previously adhered. A microscope may be fitted with a shield retention stage so that the prepared sample and shield may be retained and thereby the prepared region of the sample may be observed in the microscope. After observation the user may decide that additional sample preparation is needed. Since the sample is still durably adhered to the shield, it is a simple matter to return the sample and shield to the vacuum chamber for additional processing. The datum features on both the shield and the shield retention stage ensure that the shield may be retained in substantially the same position and orientation each time the sample is processed in the apparatus. A kit comprising a shield retention stage **40** with a plurality of datum features **70a**, **70c**, and **70e**, shield retention means **42**, and at least one shield **60** with a plurality of datum features **70b**, **70d**, and **70f** may be supplied for fitting to a microscope. Such a kit facilitates the microscopic observation of samples prepared in the ion beam sample preparation apparatus **2**.

[0119] Turning now to FIG. **2**, illustrated is a schematic cross sectional view of an embodiment of an ion beam sample preparation thermal management apparatus **2** configured to control the temperature of sample **8** while it is being prepared in the ion beam. The embodiment of FIG. **2** is shown comprising: a vacuum chamber **10** in which a sample **8** is prepared; chamber cover **18** which seals vacuum chamber **10** from the outside atmosphere; vacuum pump means **90** and pumping manifold **92** which together bring vacuum chamber **10** to vacuum levels appropriate for ion beam milling; ion beam irradiating means **20** which creates and directs an ion beam having a central ion beam axis **22** toward sample **8**; a shield **60** which shields at least a portion of sample **8** from at least a portion of the ion beam; a rotating shield retention

stage 50 which holds and accurately positions shield 60 with respect to the direction and extent of the ion beam; a shield retention means 42 which both retains shield 60 in rotating shield retention stage 50 and also urges shield 60 to remain in a position whereby the ion beam may prepare sample 8; a rotation drive 52 which rotates the rotating shield retention stage 50 about rotation axis 54; vacuum seal 56 which maintains the vacuum in vacuum chamber 10 while allowing rotating shield retention stage 50 to move about rotation axis 54; shield retention means 42 also urging thermally conductive contact between shield 60 and rotating shield retention stage 50; a first thermal transfer member 80a which is in thermally conductive contact with rotating shield retention stage 50 whereby first thermal transfer member 80a rotates with rotating shield retention stage 50; a second thermal transfer member 80b which is in thermally conductive contact with first thermal transfer member 80a and remains in thermally conductive contact with first thermal transfer member 80a while rotating shield retention stage rotates; and heat sink means 84 which conducts heat away from second thermal transfer member 80b.

[0120] With continuing reference to FIG. 2, the ion beam preferably comprises noble gas ions. Elements used for the ion beam may include but are not limited to: Argon, Xenon, and Krypton. The ion beam may also comprise a mixture of ions and neutrals. Rotating shield retention stage 50 is disposed in vacuum chamber 10 in a predetermined position and orientation with respect to central ion beam axis 22. Rotating shield retention stage 50 may additionally comprise means for measuring the rotation angle of the stage. Rotation drive 52 may additionally comprise means to reach and maintain accurate angular position. Rotation drive 52 may additionally comprise means to reach and maintain accurate angular speed. Heat sink means 84 may use gaseous nitrogen or liquid nitrogen as a heat absorbing medium. Heat sink means 84 may additionally comprise temperature control means capable of substantially maintaining second thermal transfer member 80b at a predetermined temperature. Rotating shield retention stage 50 of FIG. 2 has the same features and functions possessed by the rotating shield retention stage 50 shown in FIG. 13A and FIG. 13B. In addition, shield 60 of FIG. 2 has the same features, functions, and aspects possessed by shield 60 shown in figures FIG. 3A, FIG. 3B, FIG. 5A, FIG. 5B, FIG. 6, FIG. 7A, FIG. 7B, FIG. 8A, FIG. 8B, FIG. 13A, FIG. 13B, and FIG. 14. In a preferred embodiment as shown in FIG. 13B, rotation axis 54 lies substantially in the plane defined by the abutment of the proximal sample surface 62 with the sample 8. In a preferred embodiment of shield 60, a material with good thermal conductivity may be used to improve thermal transfer between shield and the shield retention stage, said material including but not limited to a substantially non-magnetic metal. In another preferred embodiment of shield 60, a material with good thermal conductivity can be used as a core material to improve thermal transfer between shield and the shield retention stage, and a substantially non-magnetic material with low sputtering yield may be used as a cladding material over the core material whereby the cladding material forms at least part of the shielding surface 61 of shield 60.

[0121] FIG. 13A shows a perspective schematic view of rotating shield retention stage 50 on which sample 8 has been durably adhered to shield 60 prior to placing the shield and sample combination in a shield retaining position in rotating shield retention stage 50. Shield 60 has a shielding surface 61

which is positioned in relation to sample 8 to shield at least a portion of said sample 8 from at least a portion of the ion beam. Rotation drive 52 enables rotating shield retention stage 50 to rotate about rotation axis 54. In a preferred embodiment, shield edge 63 is disposed to be substantially perpendicular to rotation axis 54 when shield 60 is held in the shield retaining position. Also shown in FIG. 13A is a section line indicating the section view shown in FIG. 13B.

[0122] FIG. 13B shows a section view illustrating the position and function of the shield retention means which is part of rotating shield retention stage 50. In FIG. 13B shield retention means first member 42a urges shield retention means second member 42b against shield 60. The action of shield retention means first member 42a also urges shield 60 against rotating shield retention stage 50 and thereby maintains the position of shield 60 within rotating shield retention stage 50 while the sample is prepared by ion beam. An embodiment of the shield retention means may comprise a spring for shield retention means first member 42a and a solid member as shield retention means second member 42b configured to slide within a cavity in rotating shield retention stage 50. The shield retention means also has a shield releasing position in which the shield and sample are not held in the rotating shield retention stage 50. The shield releasing position may be identical to the shield releasing position 48 illustrated in FIG. 4. In preferred embodiment, rotation axis 54 lies substantially in the plane defined by the abutment of the proximal sample surface 62 with the sample 8.

[0123] The rotating shield retention stage 50 has the same plurality of datum features as shown on the non-rotating shield retention stage of FIG. 6. In addition, the rotating shield retention stage 50 datum features allow the interchangeable use of shield 60 previously described. The datum features of the shield retention stage 40 and the rotating shield retention stage 50 are substantially identical in design and thereby facilitate the easy interchange of shields between the stages. By means of the two positions provided by the shield retention means, namely shield retaining position 46 as shown in FIG. 3B, and shield releasing position 48 as shown in FIG. 4, a shield may be removably and replaceably secured in rotating shield retention stage 50. A sample that has been durably adhered to shield 60 may be processed, removed, and then reprocessed by simply placing it in the shield retaining position and preparing the sample again in the ion beam. The datum features on both shield and shield retention stage assure that the shield may be positioned in a substantially identical position and orientation multiple times. In preferred embodiments that include rotating shield retention stage 50, central ion beam axis 22 passes substantially through rotation axis 54 in the region above shield edge 63. After the sample has been prepared in the ion beam chamber, cover 18 may be removed, then the shield and sample may be removed for observation in a microscope.

[0124] Use of the apparatus of FIG. 2 may proceed according to all of the steps disclosed for the use of the apparatus of FIG. 1. However, the rotating shield retention stage shown in the embodiment of FIG. 2 gives the user additional capabilities. The user may rotate the rotating shield retention stage about the rotation axis to a desired angle before sample preparation, during sample preparation, or after sample preparation. This gives the user increased flexibility in exposing a region of interest in the sample for later microscopic observation.



[0125] Turning now to FIG. 14, shown is a schematic cross sectional view of an embodiment of an ion beam sample preparation apparatus 2 adapted to control the temperature of sample 8 while it is being prepared in the ion beam. The embodiment of FIG. 14 is shown comprising: a vacuum chamber 10 in which a sample 8 is prepared, chamber cover 18 which seals vacuum chamber 10 from the outside atmosphere, vacuum pump means 90 and pumping manifold 92 which together bring vacuum chamber 10 to vacuum levels appropriate for ion beam milling, modulating ion beam irradiating means 30 which directs an ion beam having a central ion beam axis 22 toward sample 8, a modulation drive 32 which controls the intensity of the ion beam produced by modulating ion beam irradiating means 30 whereby at least two different ion beam intensities are produced, a shield 60 which shields at least a portion of sample 8 from at least a portion of the ion beam, a rotating shield retention stage 50 which holds and accurately positions shield 60 with respect to the direction and extent of the ion beam, a shield retention means 42 which both retains shield 60 in shield retention stage 50 and also urges shield 60 to remain in a position whereby the ion beam may prepare sample 8, a rotation drive 52 which rotates the rotating shield retention stage 50 about rotation axis 54, and vacuum seal 56 which maintains the vacuum in vacuum chamber 10 while allowing rotating shield retention stage 50 to move about rotation axis 54. Rotating shield retention stage 50 of FIG. 14 has the same features, functions, and aspects possessed by the rotating shield retention stage 50 shown in FIG. 13A, and FIG. 13B. Shield 60 of FIG. 14 has the same features, functions, and aspects possessed by shield 60 shown in figures FIG. 3A, FIG. 3B, FIG. 5A, FIG. 5B, FIG. 6, FIG. 7A, FIG. 7B, FIG. 8A, FIG. 8B, FIG. 13A, and FIG. 13B.

[0126] With continuing reference to FIG. 14, the ion beam preferably comprises noble gas ions. Elements used for the ion beam may include but are not limited to: Argon, Xenon, and Krypton. The ion beam may also comprise a mixture of ions and neutrals. Rotating shield retention stage 50 is disposed in vacuum chamber 10 in a predetermined position and orientation with respect to central ion beam axis 22. Rotating shield retention stage 50 may additionally comprise means for measuring the rotation angle of the stage. Rotation drive 52 may additionally comprise means to reach and maintain accurate angular position. Rotation drive 52 may additionally comprise means to reach and maintain accurate angular speed. The temperature of a sample undergoing preparation in the apparatus may be temperature controlled by modulation drive 32 by varying the intensity of the ion beam directed towards the sample. Reducing the ion beam intensity allows the sample to cool. The sample may be rotating while ion beam preparation of the sample is occurring. The angular position of rotating shield retention stage 50 may be used as a control input to modulation drive 32 and thereby the modulation drive may be configured to operate the ion beam at higher intensity for a portion of each rotation and operate at a lower intensity for the remainder of each rotation. In a preferred embodiment a measurement or estimate of the sample temperature may be used to determine the amount of reduction of the ion beam intensity that is required to maintain the sample temperature below a predetermined safe limit. In a preferred embodiment rotating shield retention stage 50 is rotated at a constant angular speed, modulating ion beam irradiating means 30 operates at a higher intensity for about a 60 degree portion of each full rotation and a lower intensity

for about 300 degrees of rotation of each full rotation. When operating modulating ion beam irradiating means 30 at a higher intensity for a portion of a full rotation it is preferred to have the angular center of the high intensity portion occur when the proximal sample surface 62 of shield 60 is oriented substantially perpendicular to central ion beam axis 22.

[0127] Use of the apparatus of FIG. 14 may proceed according to all of the steps disclosed for the use of the apparatus of FIG. 2. However, the modulating ion beam irradiating means and modulation drive shown in the embodiment of FIG. 14 give the user additional capabilities. In particular the rotation drive and the modulation drive may operate in concert to accurately and repeatably control the ion beam intensity as a function of the rotation angle of the rotating shield retention stage. This gives the user increased flexibility in exposing and preparing a region of interest in the sample for later microscopic observation.

[0128] Although the present invention has been described in considerable detail with reference to certain preferred versions thereof, other versions are possible. It may be desirable to combine features shown in various embodiments into a single embodiment. For example: a modulating ion beam sample preparation apparatus with a rotating shield retention stage and further comprising thermal transfer members, heat sink means, and modulation drive, may be constructed entirely within the spirit and scope of the present disclosure. Therefore, the spirit and scope of the appended claims should not be limited to the description of the preferred versions contained herein.

[0129] Any element in a claim that does not explicitly state "means for" performing a specified function, or "step for" performing a specific function, is not to be interpreted as a "means" or "step" clause as specified in 35 U.S.C. Section 112, Paragraph 6. In particular, the use of "step of" in the claims herein is not intended to invoke the provisions of 35 U.S.C. Section 112, Paragraph 6.

The invention claimed is:

1. An ion beam shield for use in preparing a sample in an ion beam sample preparation apparatus, the ion beam sample preparation apparatus having: an ion beam irradiating means configured to produce an ion beam; and, a shield retention stage in which the shield retention stage comprises a first datum feature, a second datum feature, and a shield retention means having at least a shield releasing position and a shield retaining position, the shield comprising:

- a) a rigid planar portion configured to be removeably and replaceably held in the shield retention stage;
- b) a proximal sample surface configured to durably adhere the sample to the shield;
- c) a first shielding surface disposed in the path of the ion beam and positioned to shield a portion of the ion beam directed at the sample when said shield is held in the shield retaining position of the shield retention means;
- d) a third datum feature formed integrally with said shield and configured such that the shield retention means in the shield retaining position urges said third datum feature to abut said first datum feature; and,
- e) a fourth datum feature formed integrally with said shield and configured such that the shield retention means in said shield retaining position urges said fourth datum feature to abut said second datum feature.

2. The apparatus of claim 1 wherein the first shielding surface meets said proximal sample surface at an angle of less than about 90 degrees and more than about 80 degrees.

3. The apparatus of claim 1 wherein the first shielding surface meets said proximal sample surface at an angle of less than about 87 degrees and more than about 83 degrees.

4. The apparatus of claim 1 wherein the first shielding surface is made of non-magnetic material having low sputtering yield.

5. The apparatus of claim 1 wherein at least a portion of the first shielding surface is made of tantalum or titanium.

6. The apparatus of claim 1 wherein the third datum feature is a datum surface and at least a portion of said datum surface is coextensive with at least a portion of said proximal sample surface.

7. The apparatus of claim 1 wherein the proximal sample surface has at least one recessed portion configured for the flowing of adhesive between the shield and the sample.

8. The apparatus of claim 1 wherein the shield further comprises a sample clamping means coupled to the shield and configured to hold the sample against said proximal sample surface.

9. The apparatus of claim 1 wherein the shield further comprises:

- a) a second shielding surface having a portion disposed in the path of a portion of the ion beam when said shield is held in the shield retaining position of the shield retention means;
- b) a shield edge formed where the first shielding surface meets the proximal sample surface; and,
- c) a visible alignment mark on the second shielding surface, configured such that the location of said visible alignment mark is in a predetermined relationship to the region where the ion beam impinges on said shield edge when said shield is held in the shield retaining position of the shield retention means.

10. The apparatus of claim 1 wherein the shield is made of a cladding material joined to a core material such that a portion of the cladding material forms at least a portion of the first shielding surface, and a portion of the core material forms said third datum feature of the shield and said fourth datum feature of the shield.

11. The apparatus of claim 10 wherein the core material comprises copper.

12. An ion beam shield for use in preparing a sample in an ion beam sample preparation apparatus, the ion beam sample preparation apparatus having: an ion beam irradiating means configured to produce an ion beam; and, a shield retention stage in which the shield retention stage comprises a first datum feature, a second datum feature, a fifth datum feature, and a shield retention means having at least a shield releasing position and a shield retaining position, the shield comprising:

- a) a rigid planar portion configured to be removeably and replaceably held in the shield retention stage;
- b) a proximal sample surface configured to durably adhere the sample to the shield;
- c) a first shielding surface disposed in the path of the ion beam and positioned to shield a portion of the ion beam directed at the sample when said shield is held in the shield retaining position of the shield retention means;

d) a third datum feature formed integrally with said shield and configured such that the shield retention means in the shield retaining position urges said third datum feature to abut said first datum feature;

e) a fourth datum feature formed integrally with said shield and configured such that the shield retention means in said shield retaining position urges said fourth datum feature to abut said second datum feature; and,

f) a sixth datum feature formed integrally with the shield and configured such that the shield retention means in said shield retaining position urges said sixth datum feature to abut said fifth datum feature.

13. The apparatus of claim 12 wherein the first shielding surface meets said proximal sample surface at an angle of less than about 90 degrees and more than about 80 degrees.

14. The apparatus of claim 12 wherein the first shielding surface meets said proximal sample surface at an angle of less than about 87 degrees and more than about 83 degrees.

15. The apparatus of claim 12 wherein the first shielding surface is made of non-magnetic material having low sputtering yield.

16. The apparatus of claim 12 wherein at least a portion of the first shielding surface is made of tantalum or titanium.

17. The apparatus of claim 12 wherein the third datum feature is a datum surface and at least a portion of said datum surface is coextensive with at least a portion of said proximal sample surface.

18. The apparatus of claim 12 wherein the proximal sample surface has at least one recessed portion configured for the flowing of adhesive between the shield and the sample.

19. The apparatus of claim 12 wherein the shield further comprises a sample clamping means coupled to the shield and configured to hold the sample against said proximal sample surface.

20. The apparatus of claim 12 wherein the shield further comprises:

- a) a second shielding surface having a portion disposed in the path of a portion of the ion beam when said shield is held in the shield retaining position of the shield retention means;
- b) a shield edge formed where the first shielding surface meets the proximal sample surface; and,
- c) a visible alignment mark on the second shielding surface, configured such that the location of said visible alignment mark is in a predetermined relationship to the region where the ion beam impinges on said shield edge when said shield is held in the shield retaining position of the shield retention means.

21. The apparatus of claim 12 wherein the shield is made of a cladding material joined to a core material such that a portion of the cladding material forms at least a portion of the first shielding surface, and a portion of the core material forms said third datum feature of the shield and said fourth datum feature of the shield.

22. The apparatus of claim 21 wherein the core material comprises copper.

\* \* \* \* \*