



US 20130152285A1

(19) **United States**

(12) **Patent Application Publication**
Sutton et al.

(10) **Pub. No.: US 2013/0152285 A1**

(43) **Pub. Date: Jun. 20, 2013**

(54) **LIGHTWEIGHT AND FLEXIBLE PROTECTIVE EQUIPMENT SYSTEM**

Publication Classification

(71) Applicant: **Drandalie, LLC**, Yuba City, CA (US)

(51) **Int. Cl.**
A41D 13/015 (2006.01)

(72) Inventors: **Andrew C. Sutton**, Corona del Mar, CA (US); **Douglas P. Gibbs**, Yuba City, CA (US); **Jason E. Sannar**, Live Oak, CA (US)

(52) **U.S. Cl.**
CPC *A41D 13/0155* (2013.01)
USPC **2/455**

(73) Assignee: **DRANDALIE, LLC.**, Yuba City, CA (US)

(57) **ABSTRACT**

A lightweight and flexible protective equipment system for effectively protecting a person from injury without significantly limiting their body movement or causing fatigue. The lightweight and flexible protective equipment system generally includes a plurality of compartments filled with a gas. The compartments are formed utilizing a first membrane attached to a second membrane at selected sealed portions along with a sealed perimeter. The first membrane and the second membrane are comprised of a plastic material capable of incurring significant impacts without rupturing. The protective padding may be covered by a shield to protect the exterior portion of the protective padding. The protective padding may be worn externally, internally or within the clothing of an individual to protect specific portions of the individual's body.

(21) Appl. No.: **13/722,001**

(22) Filed: **Dec. 20, 2012**

Related U.S. Application Data

(60) Provisional application No. 61/630,969, filed on Dec. 20, 2011.

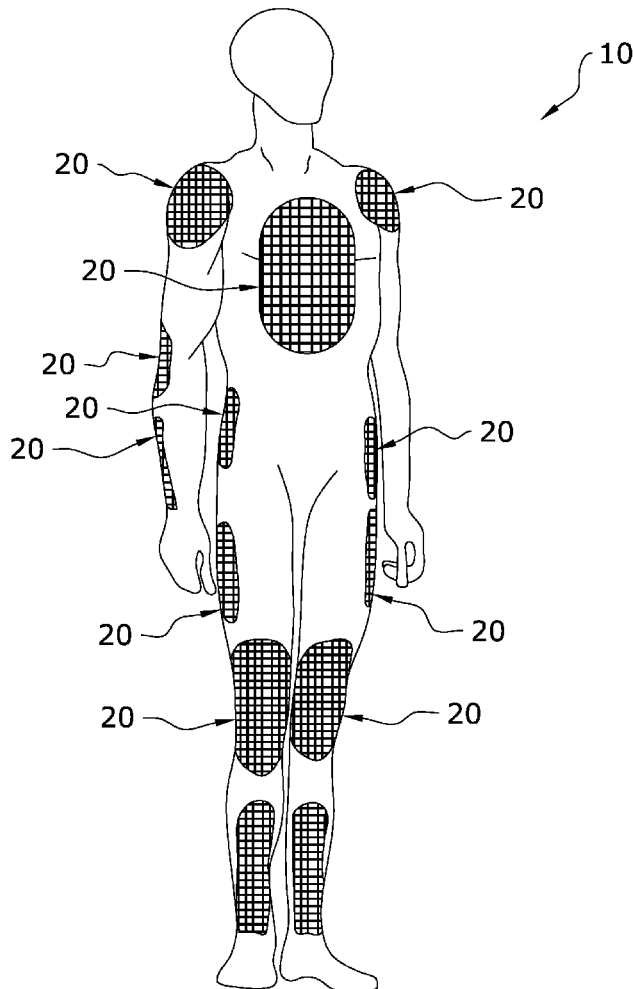

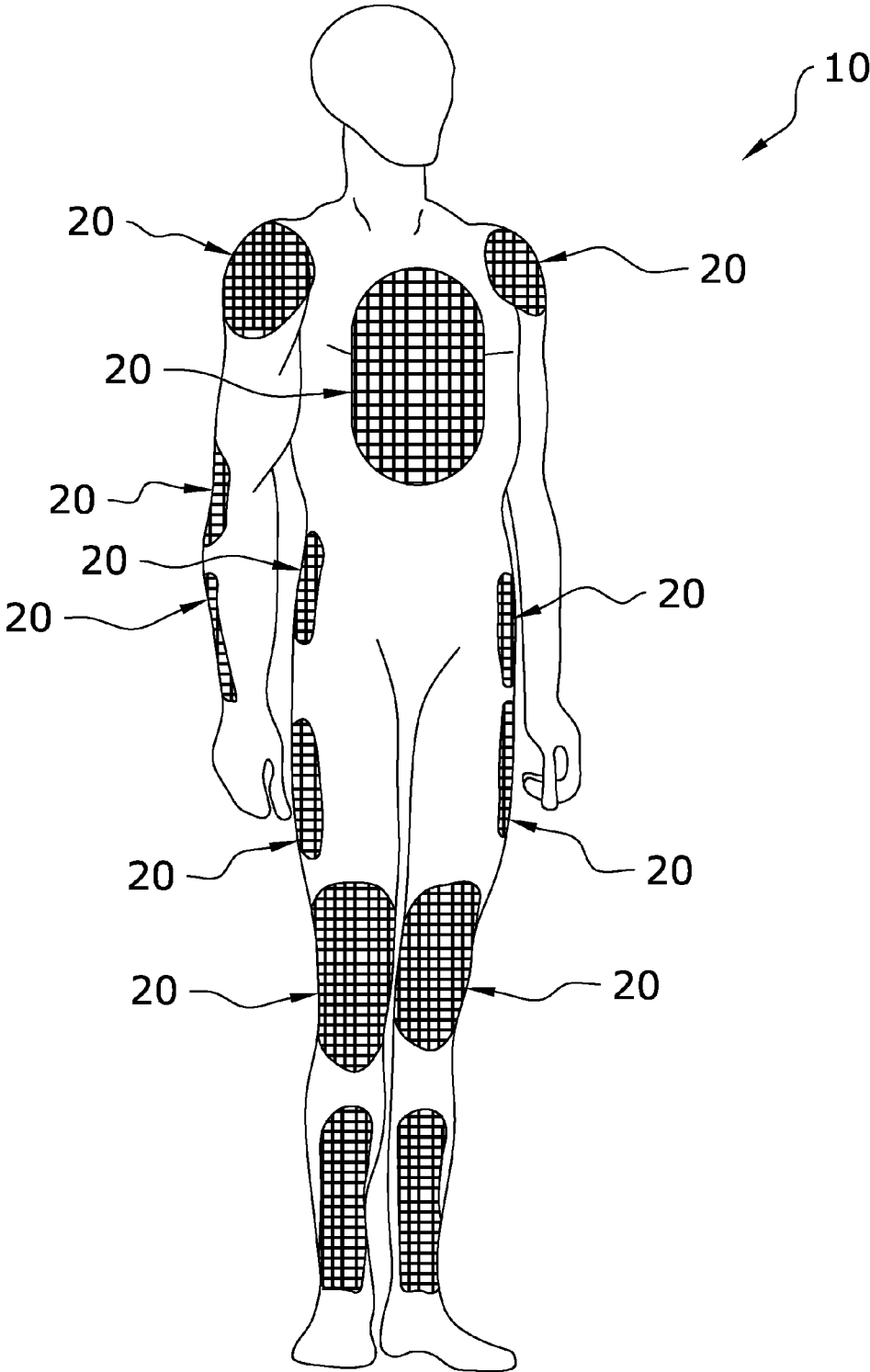

FIG. 1a

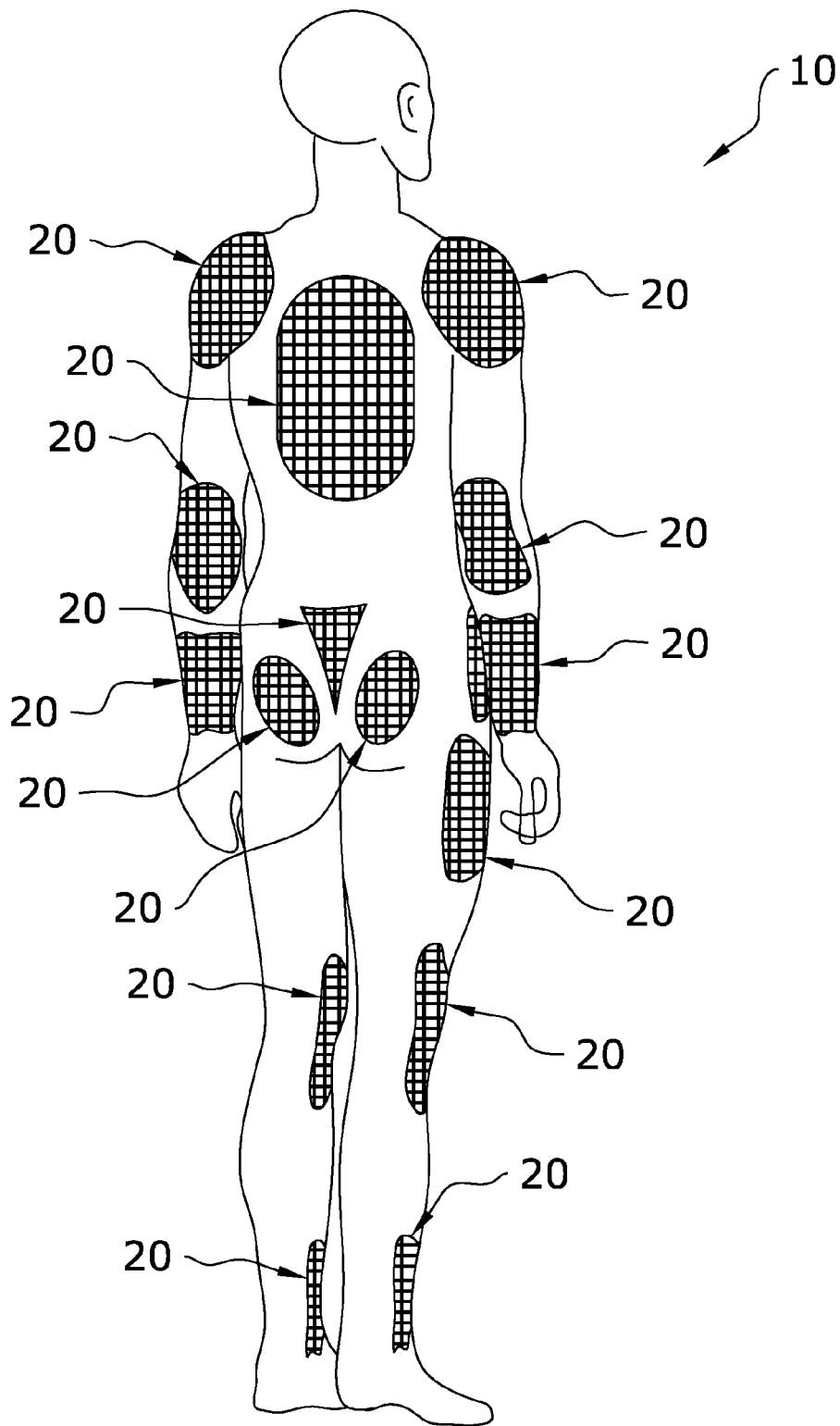

FIG. 1b

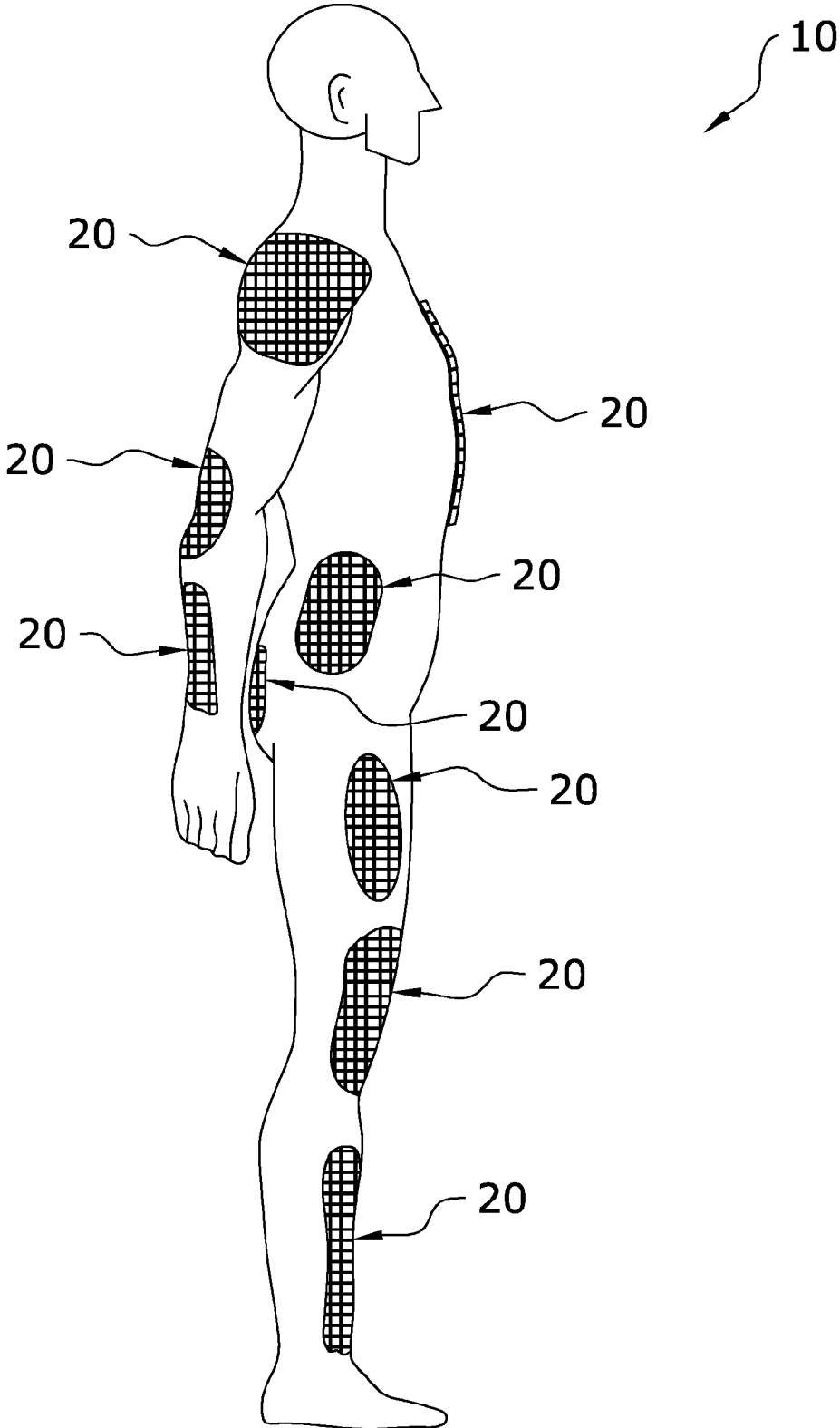

FIG. 1c

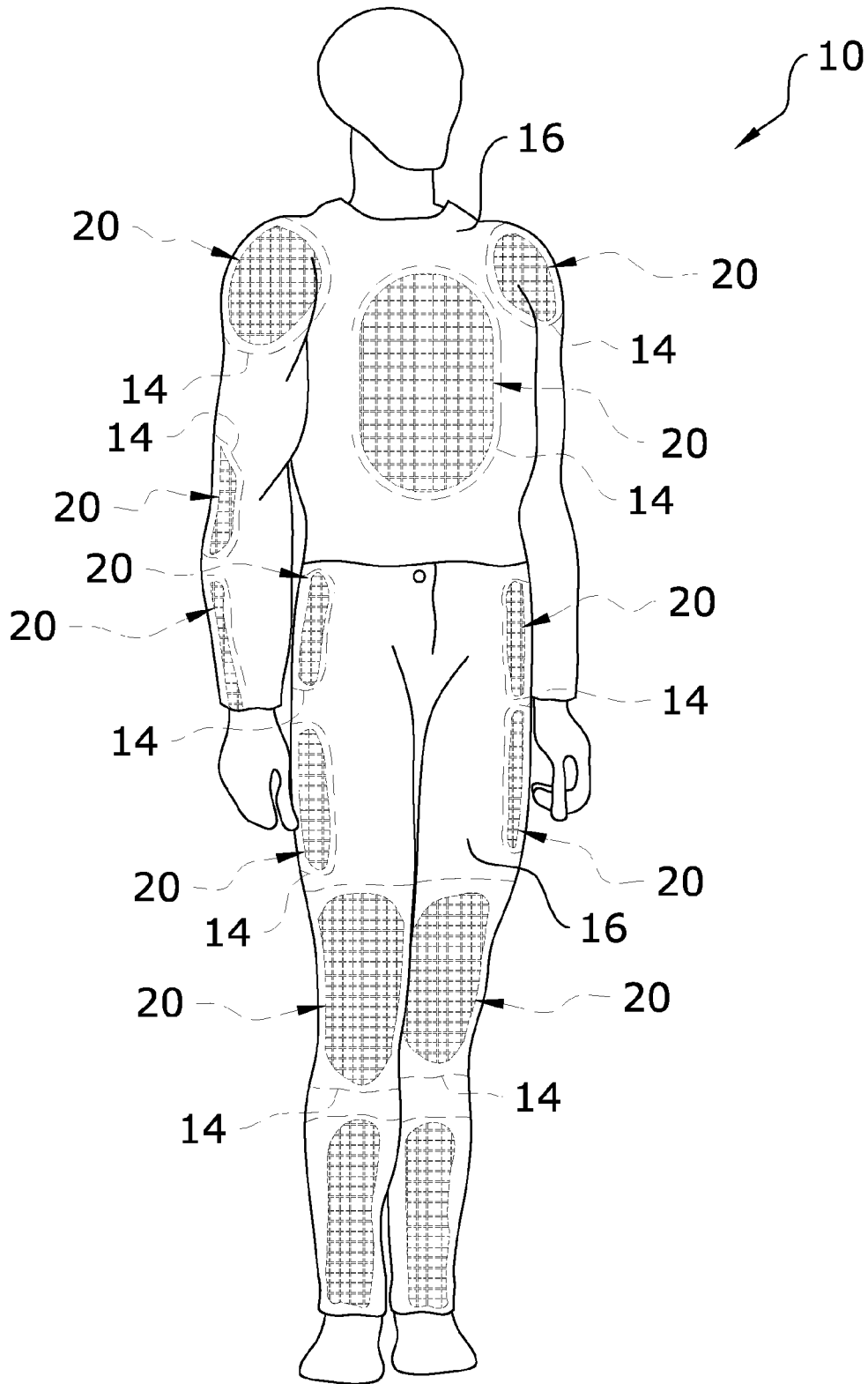

FIG. 2a

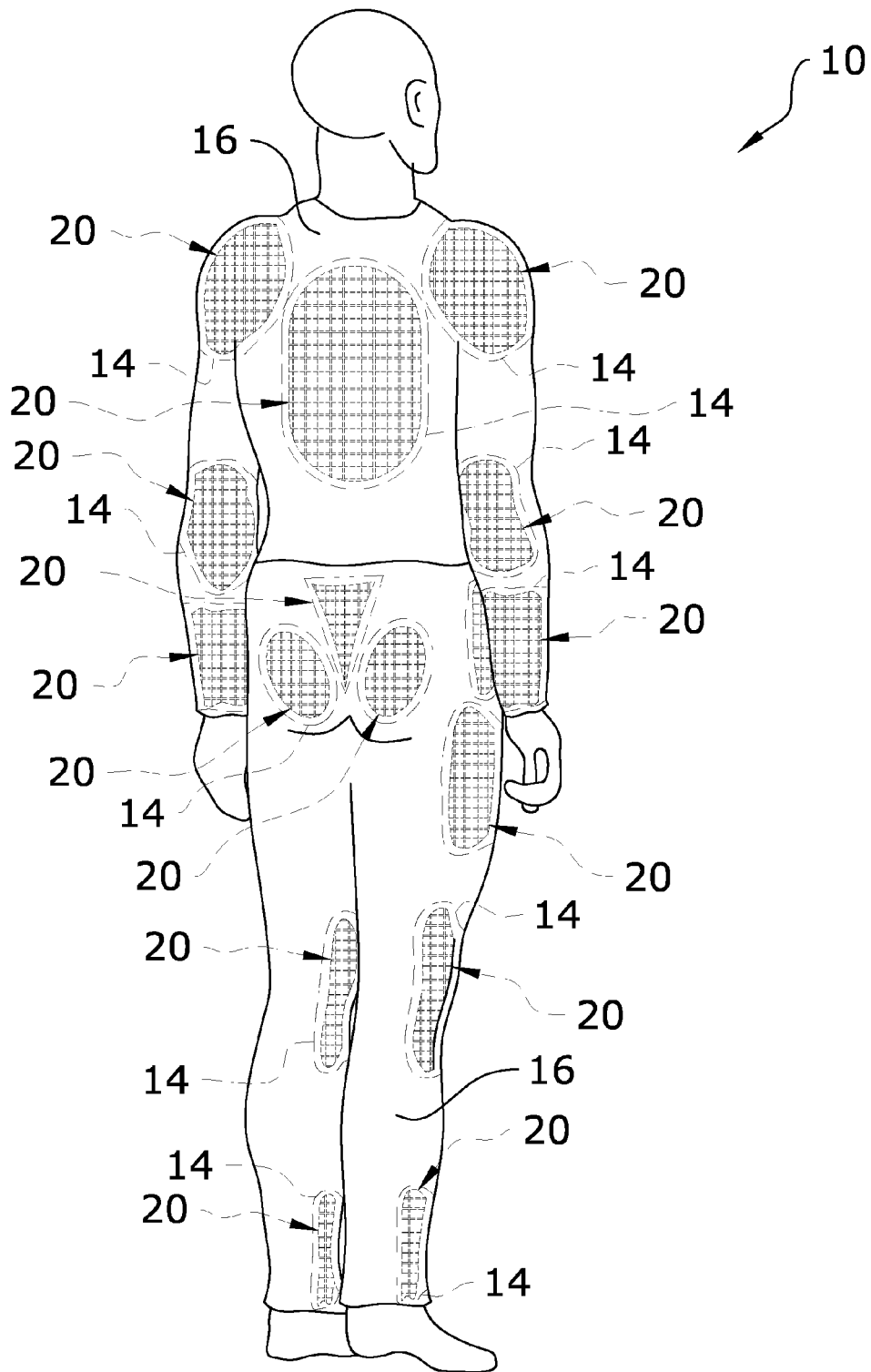

FIG. 2b

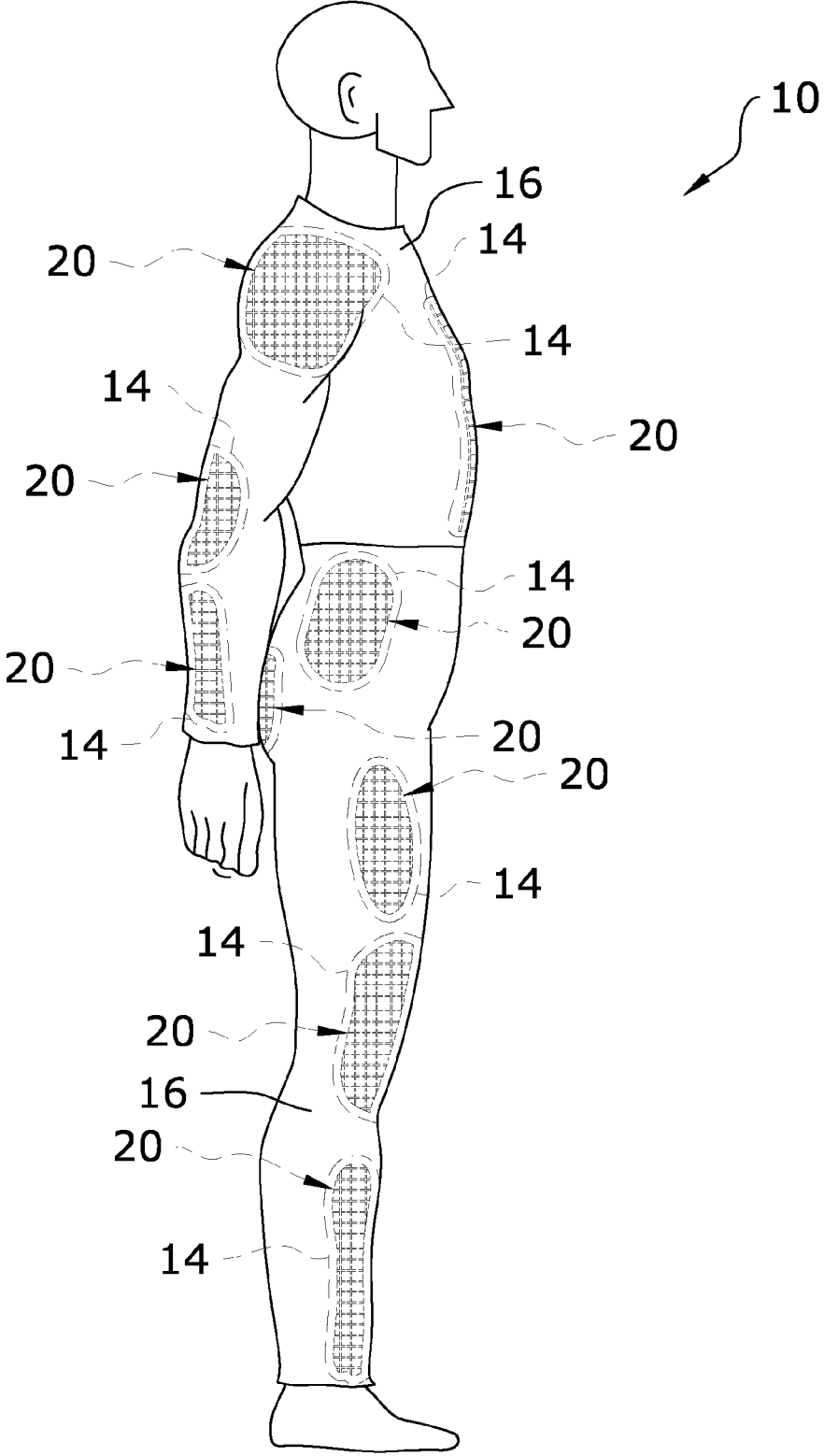

FIG. 2c

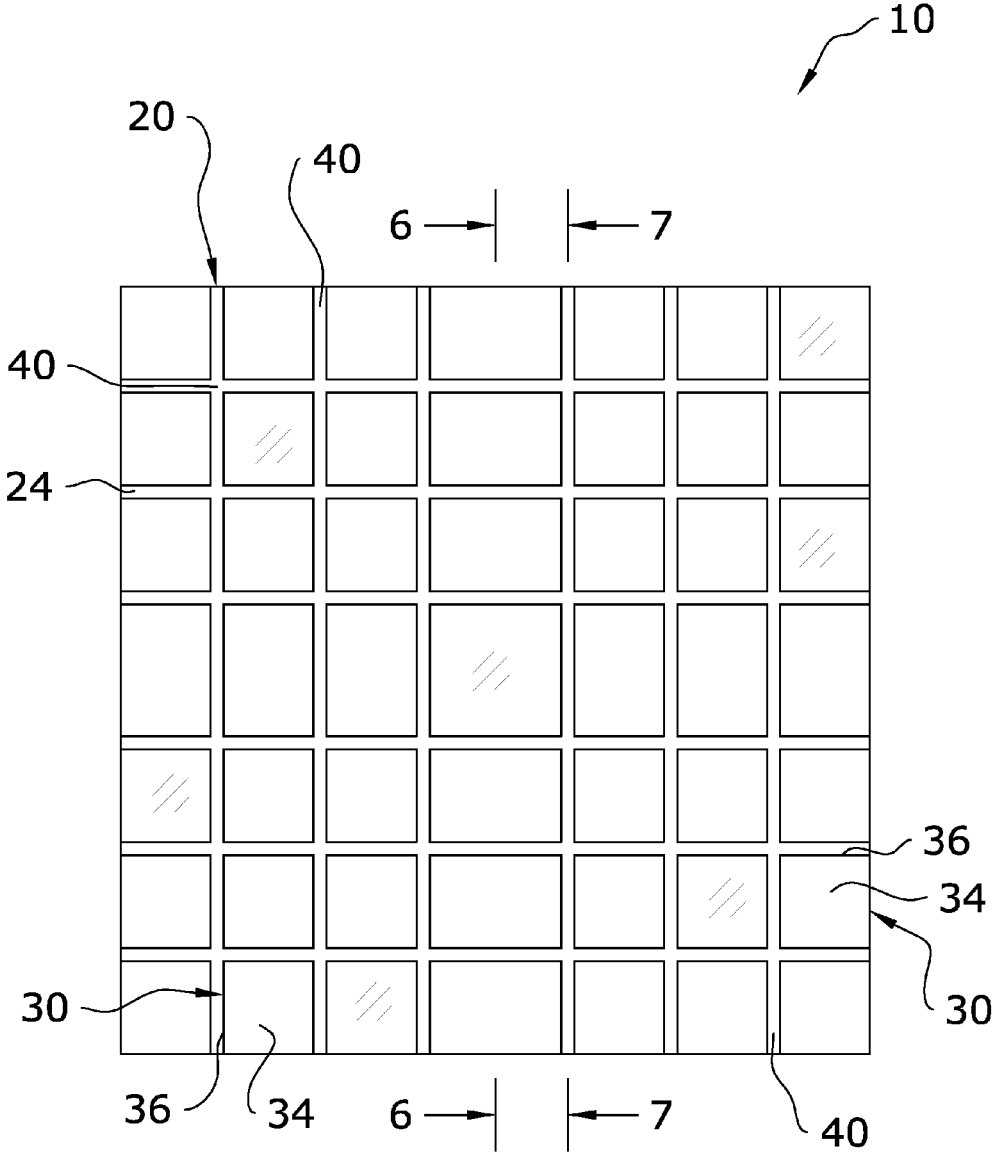

FIG. 3a

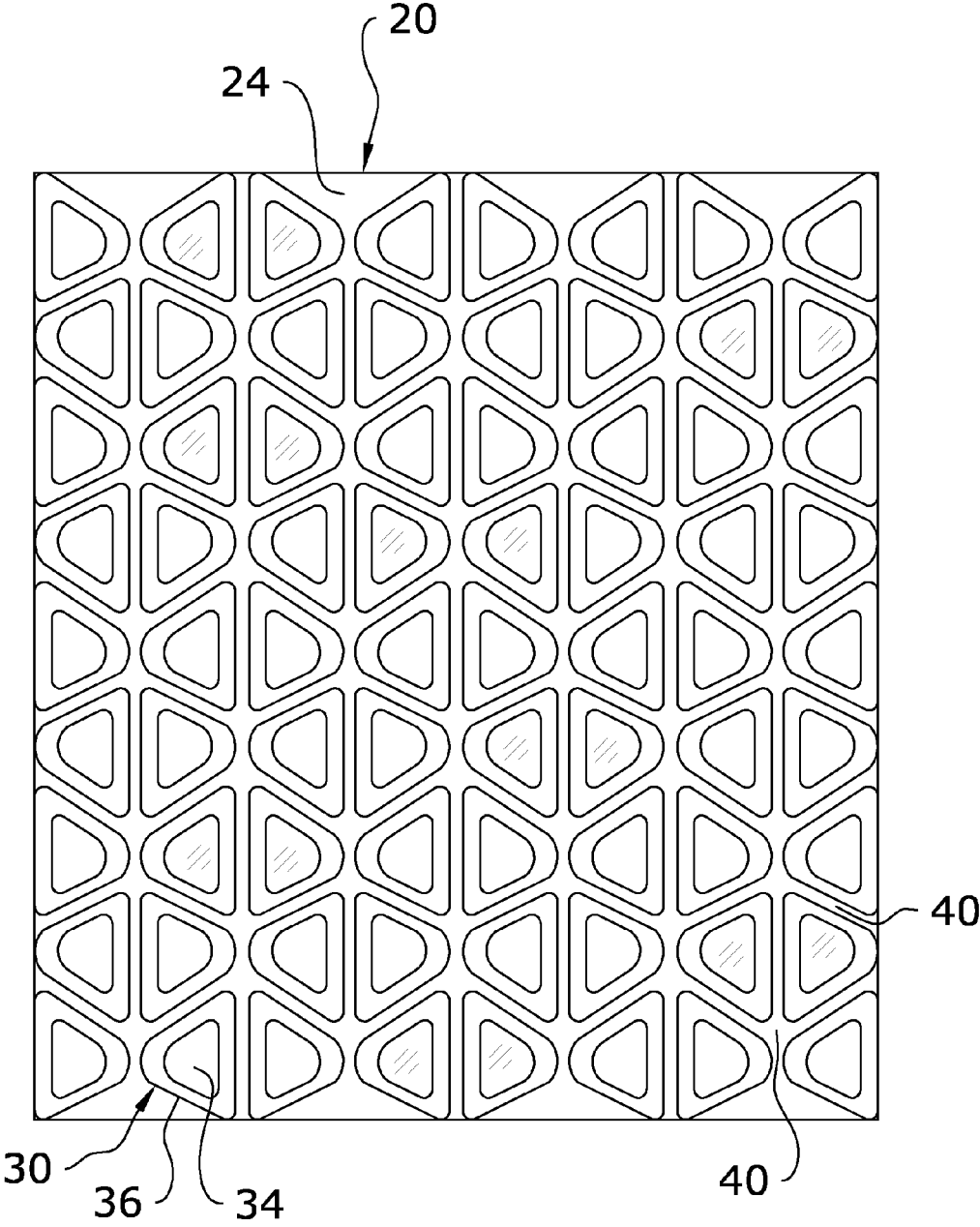

FIG. 3b

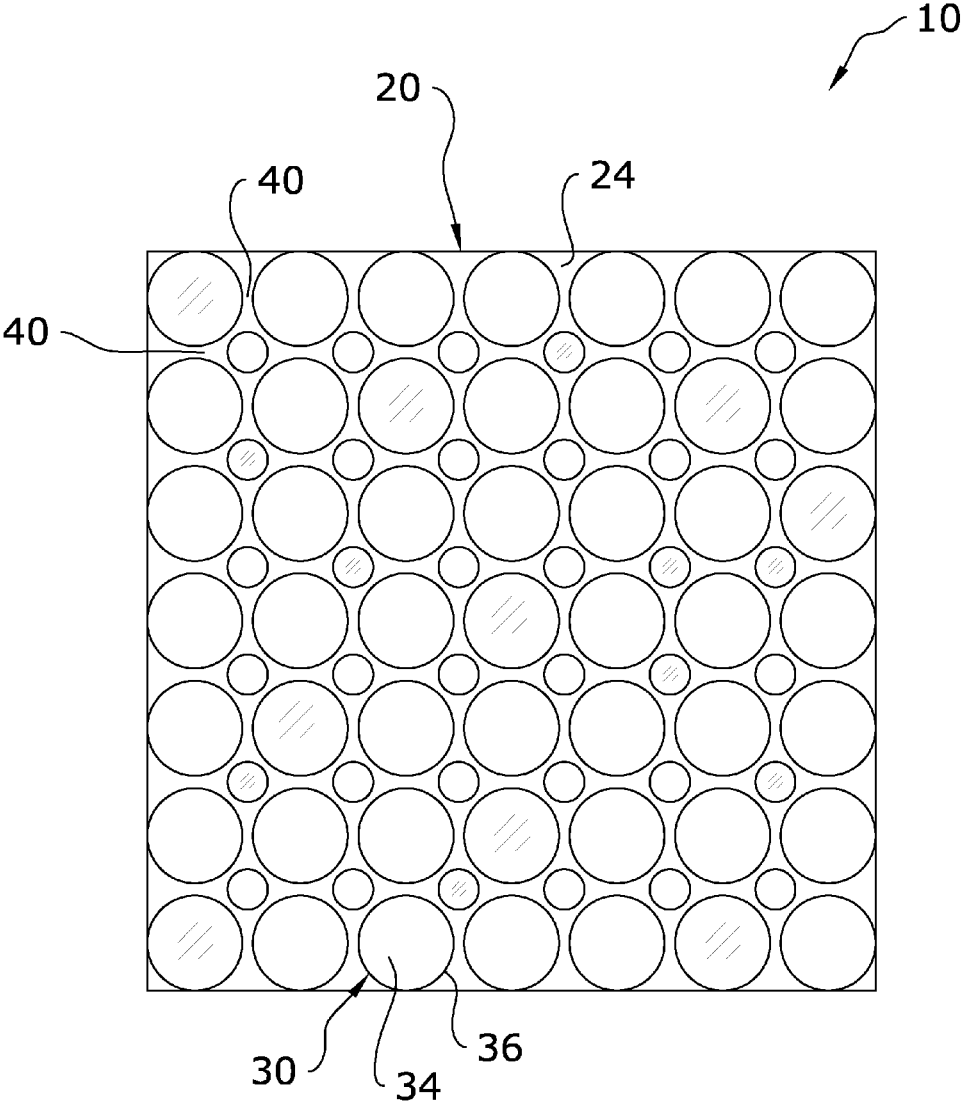

FIG. 3c

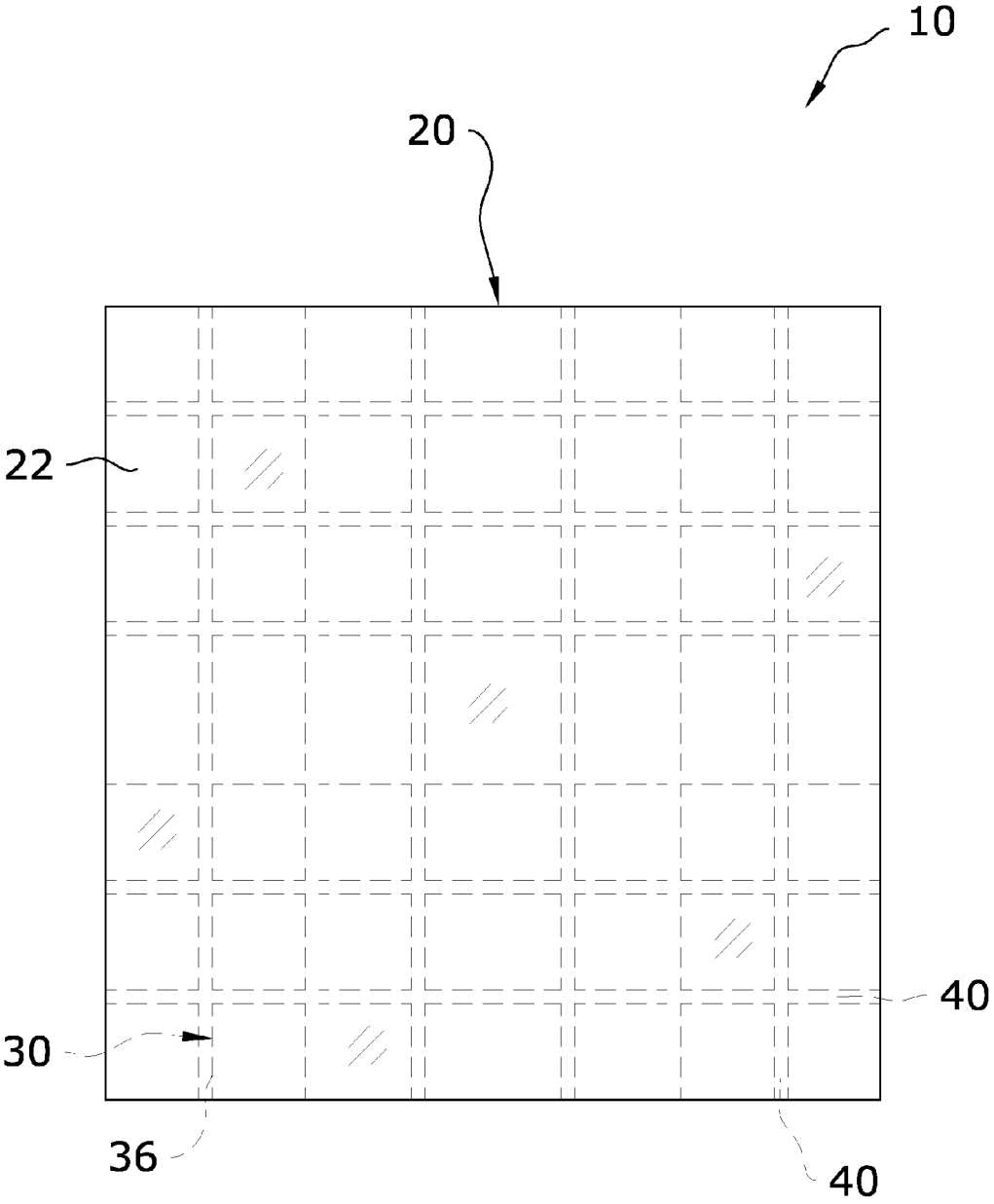

FIG. 4

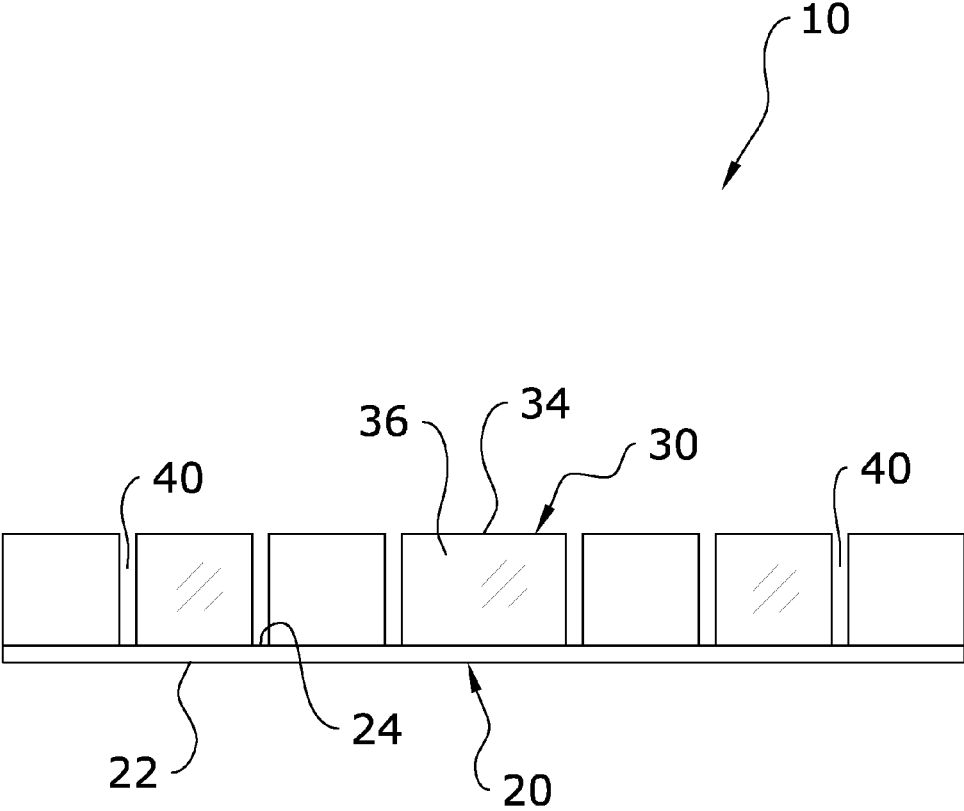

FIG. 5

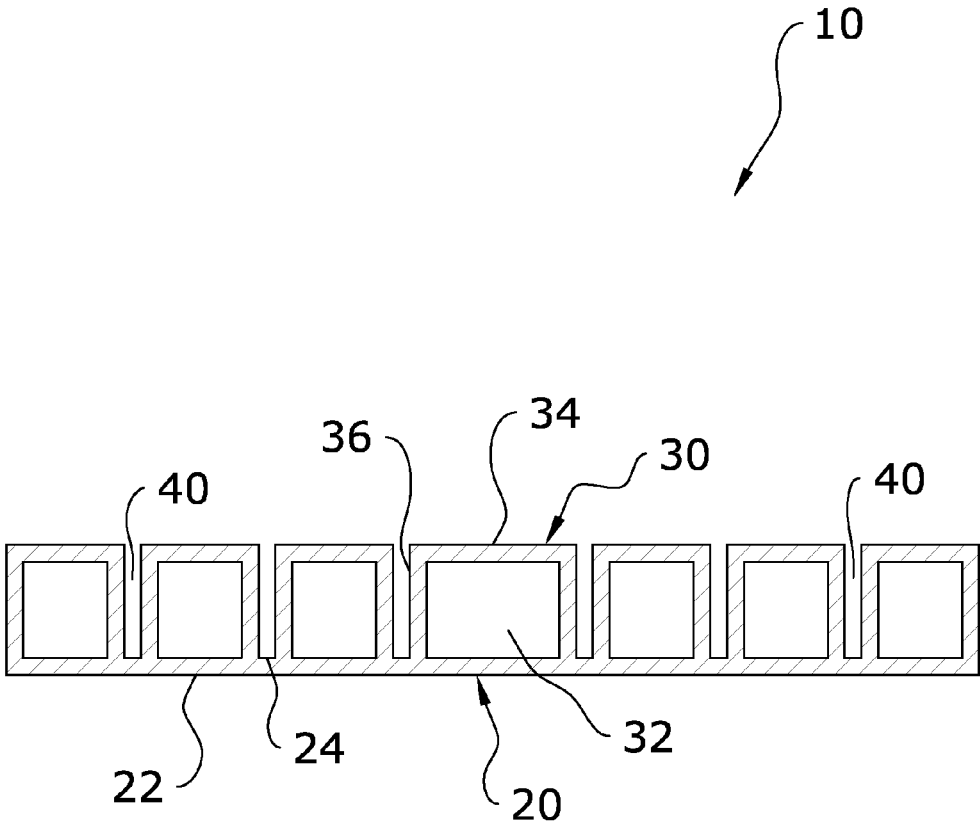

FIG. 6a

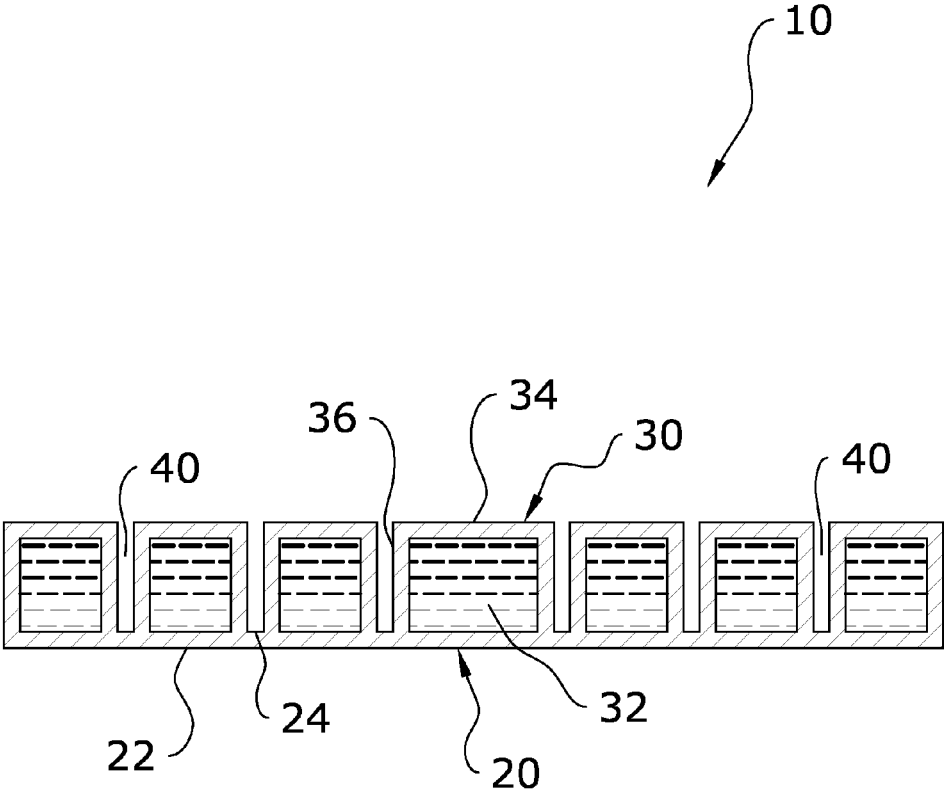

FIG. 6b

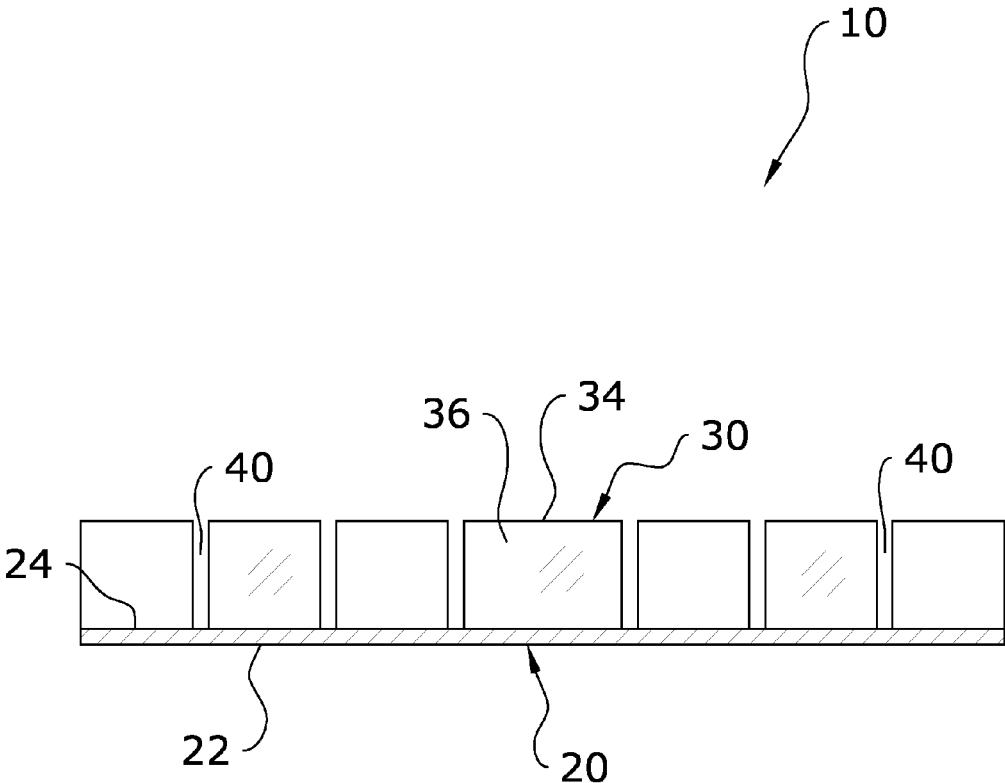

FIG. 7

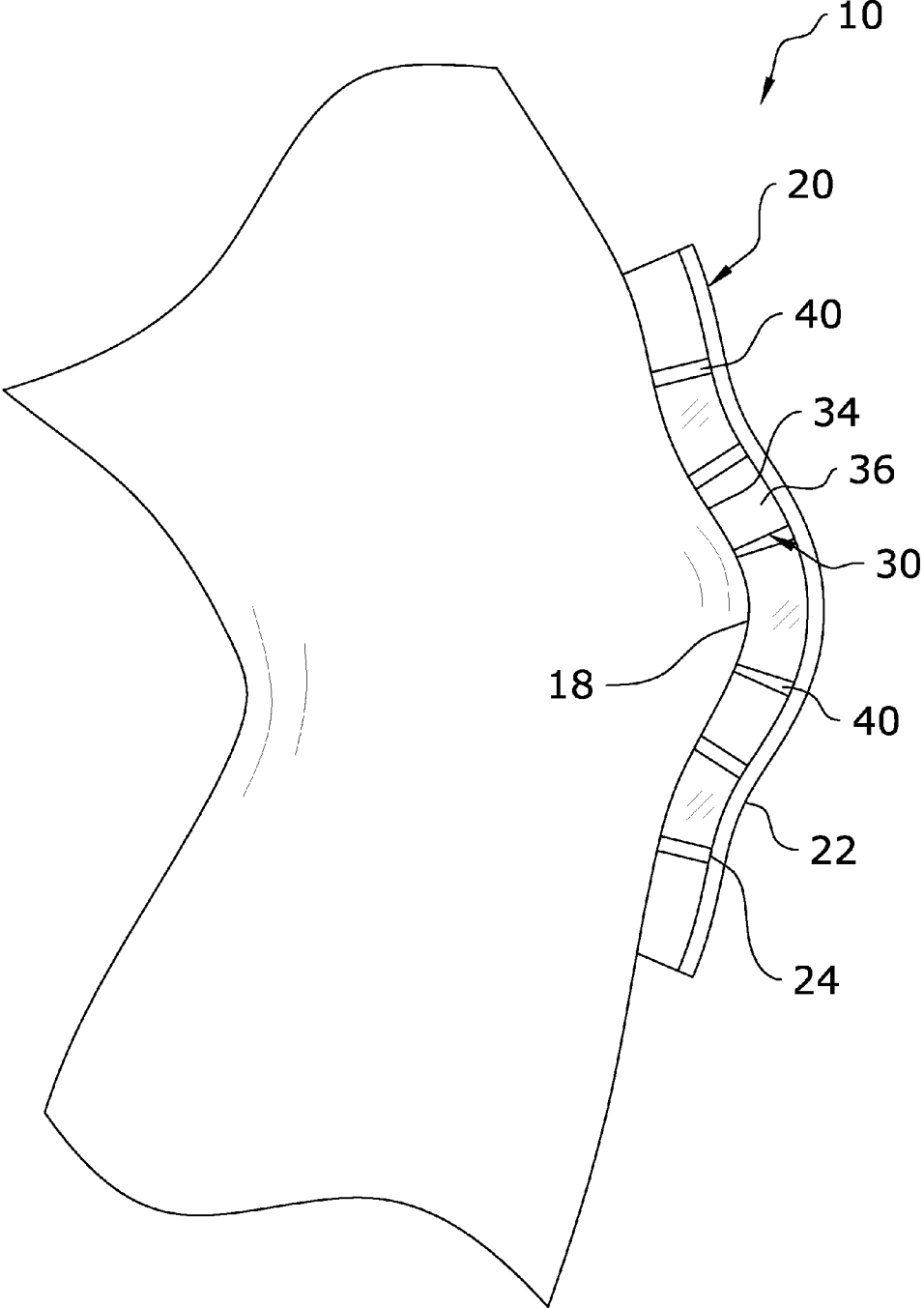

FIG. 8a

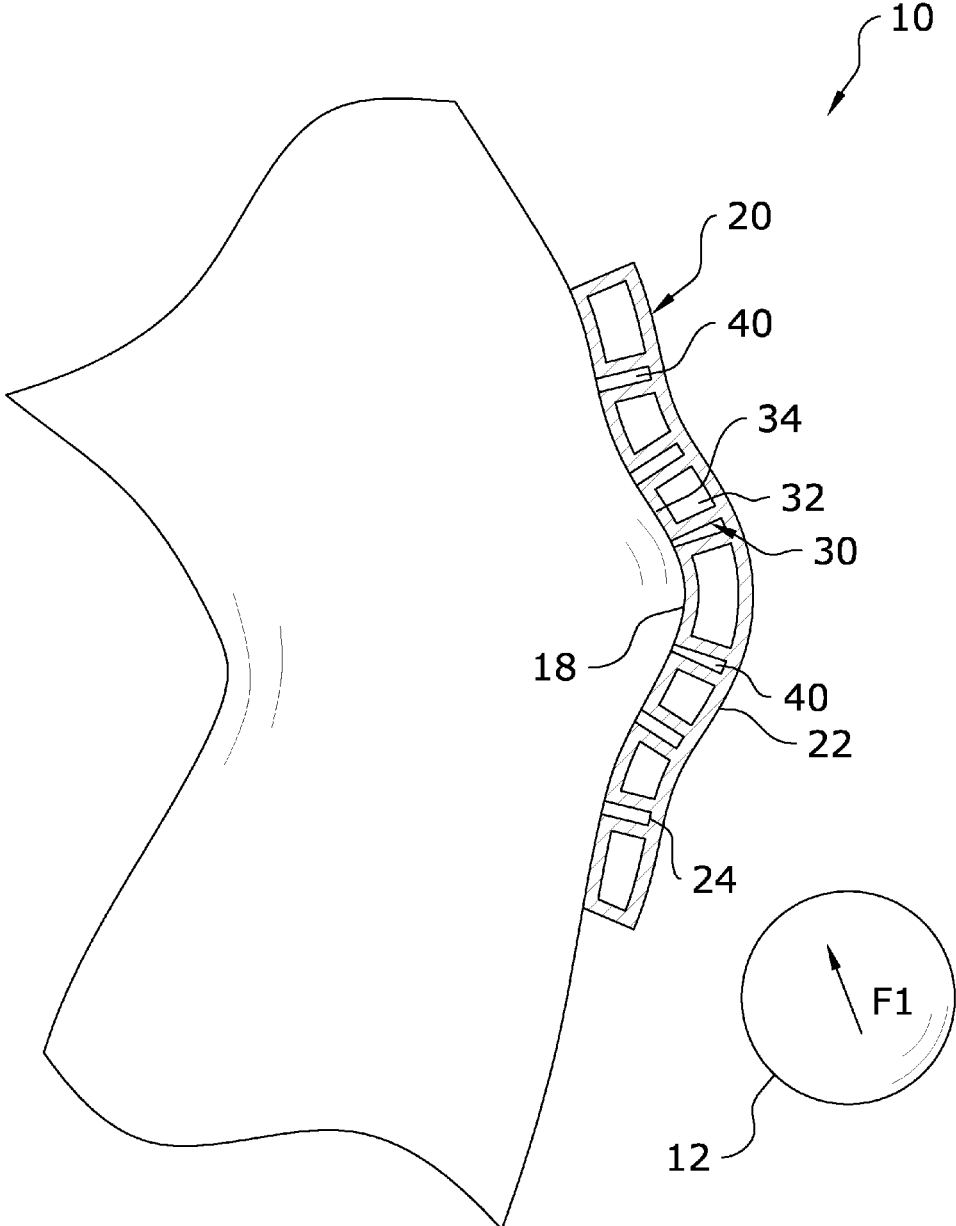

FIG. 8b

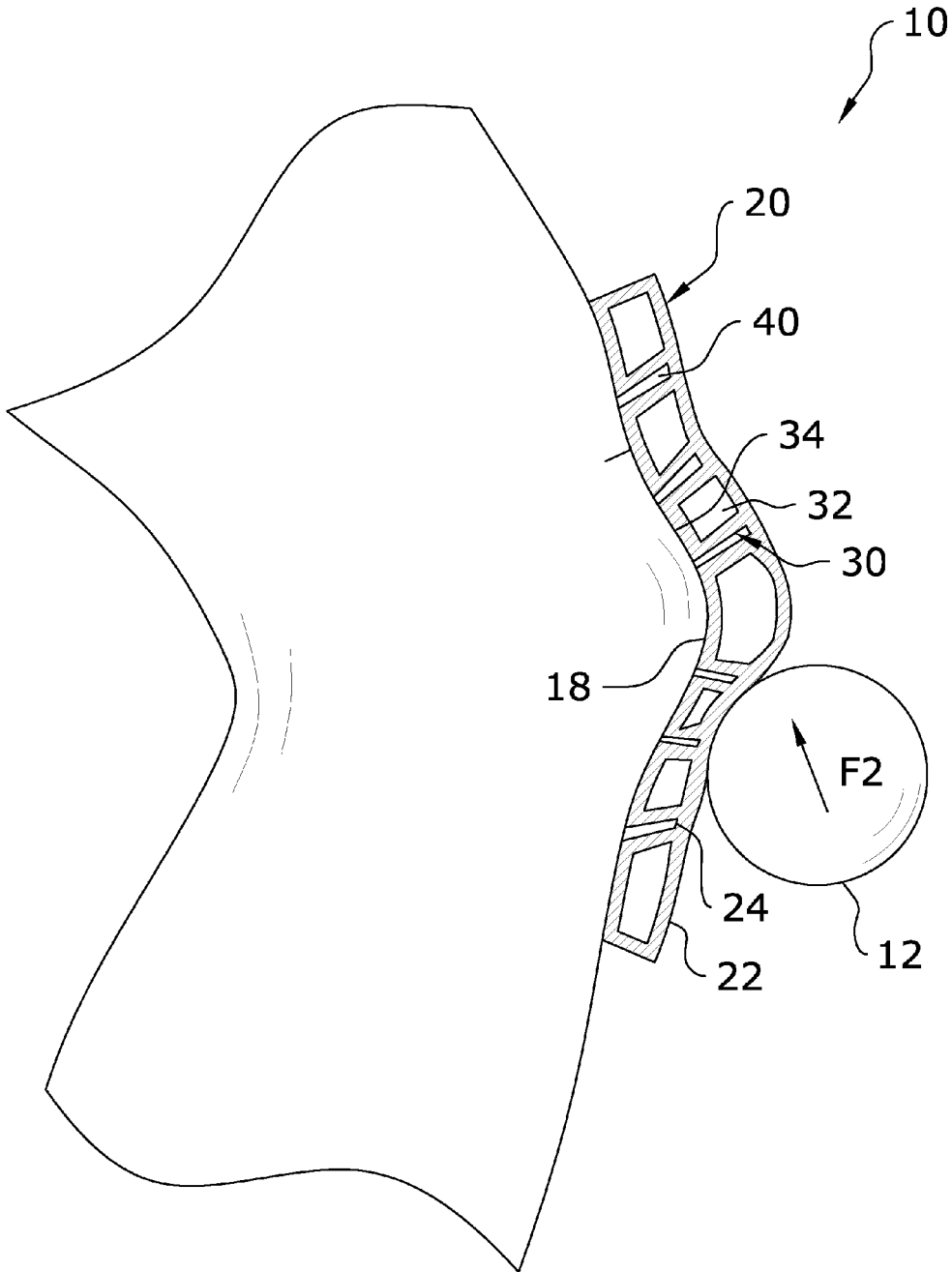

FIG. 8c

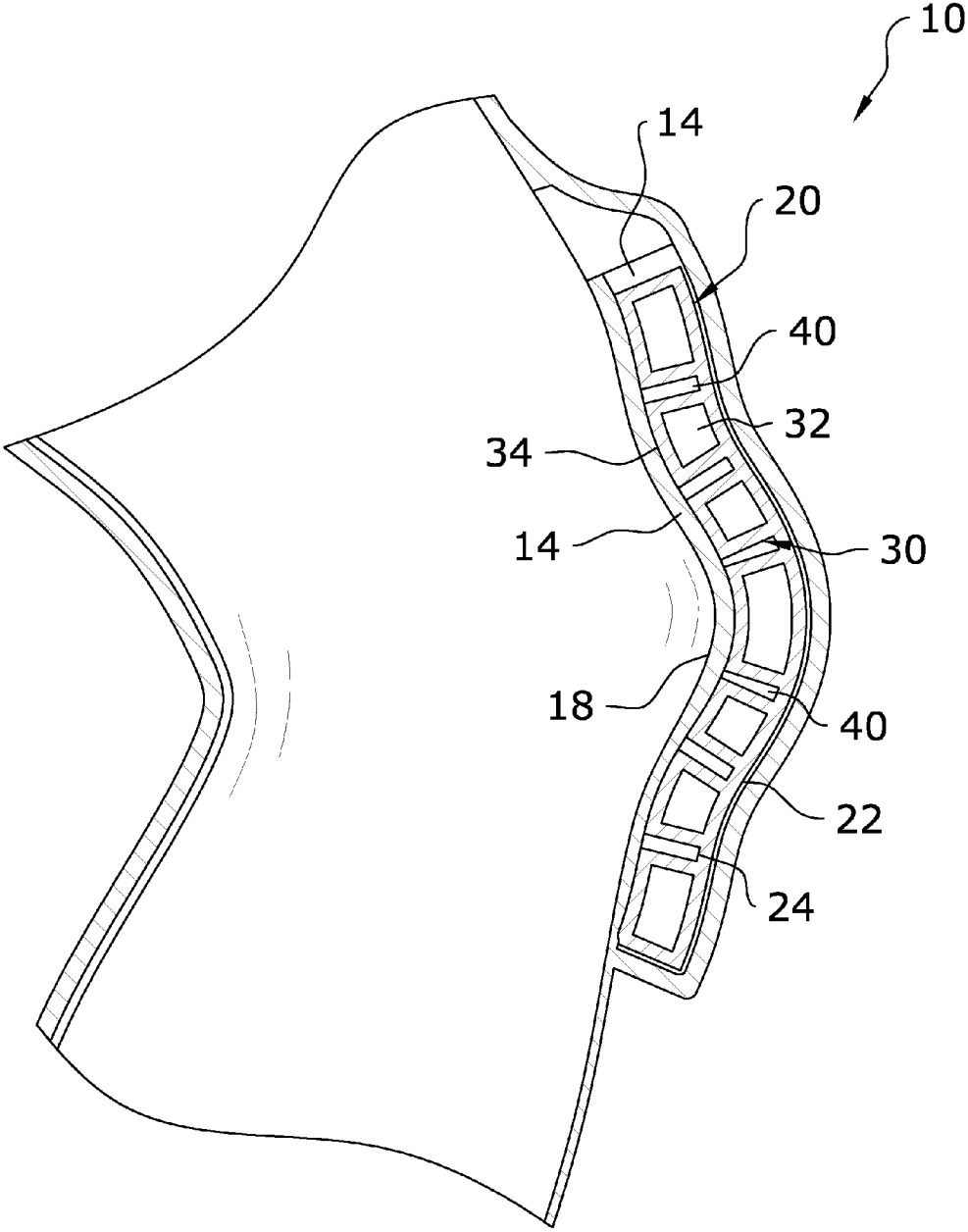
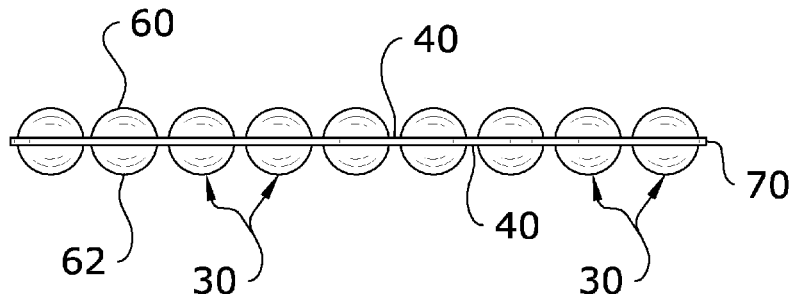
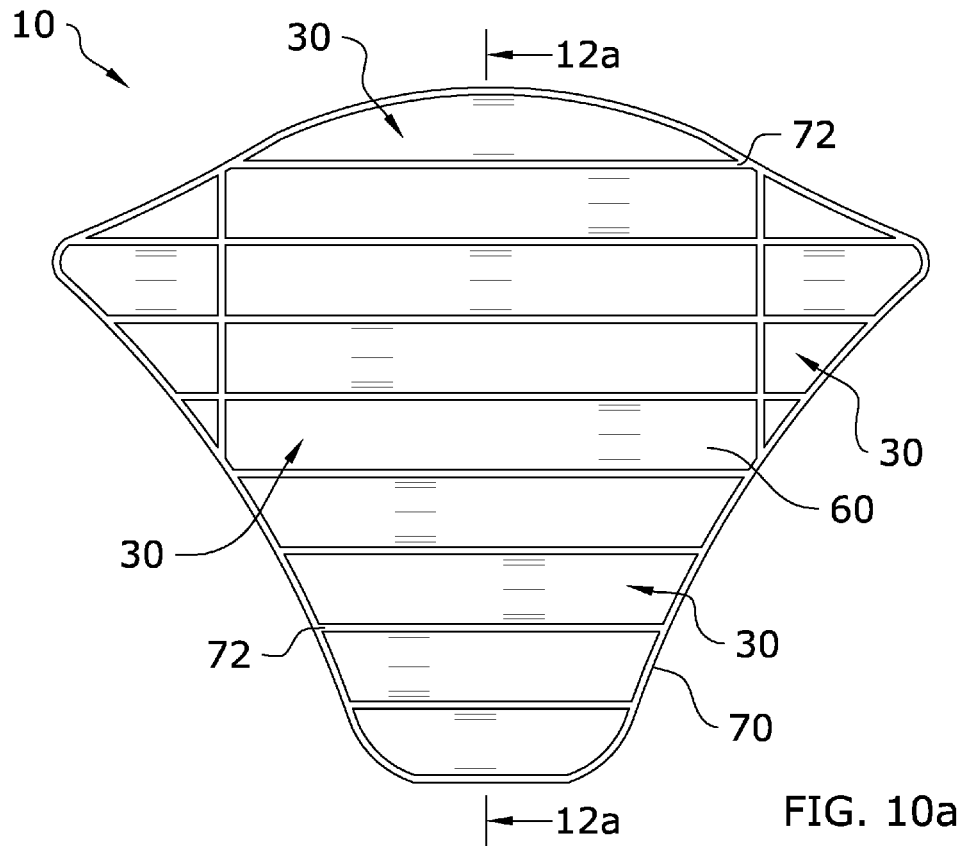
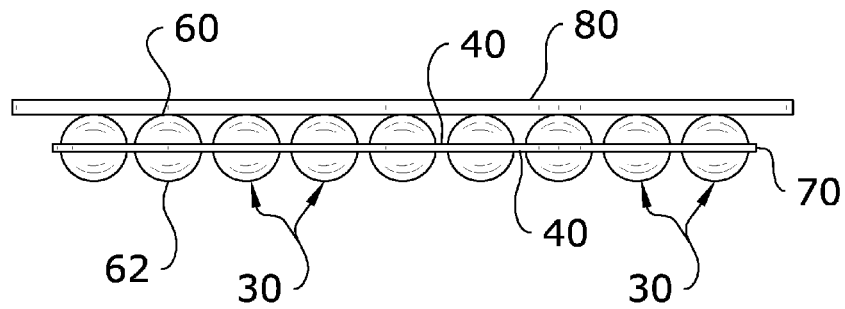
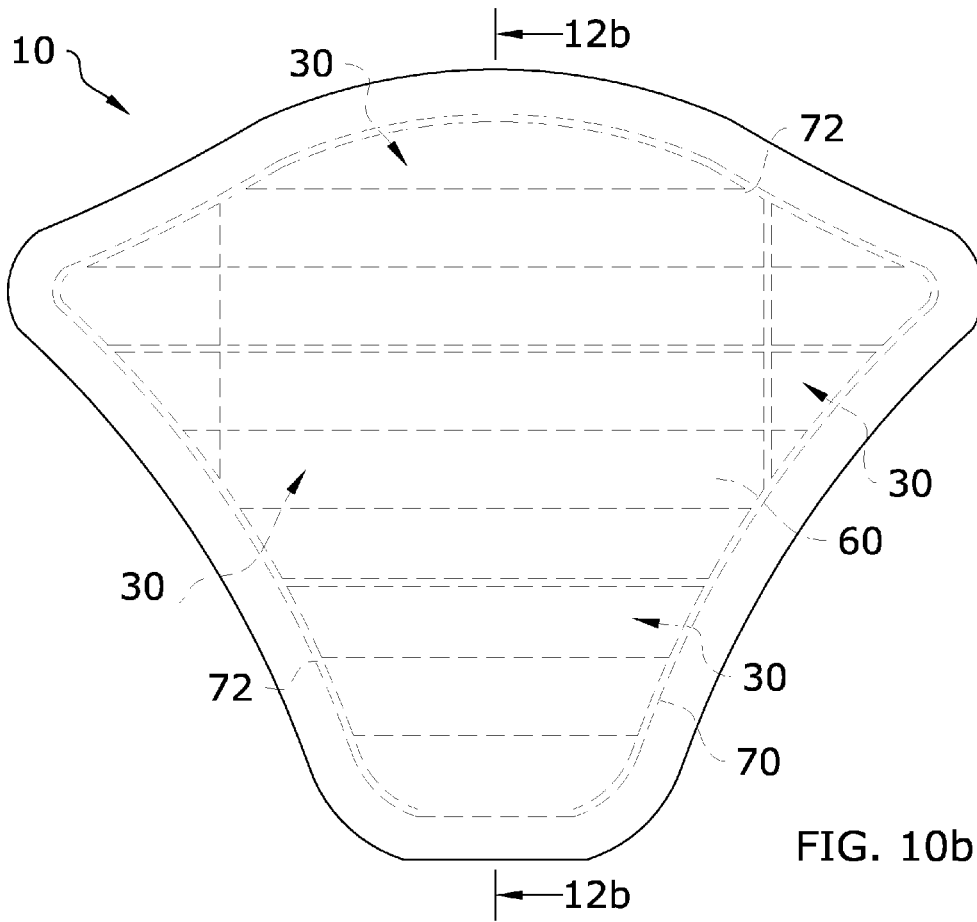

FIG. 9





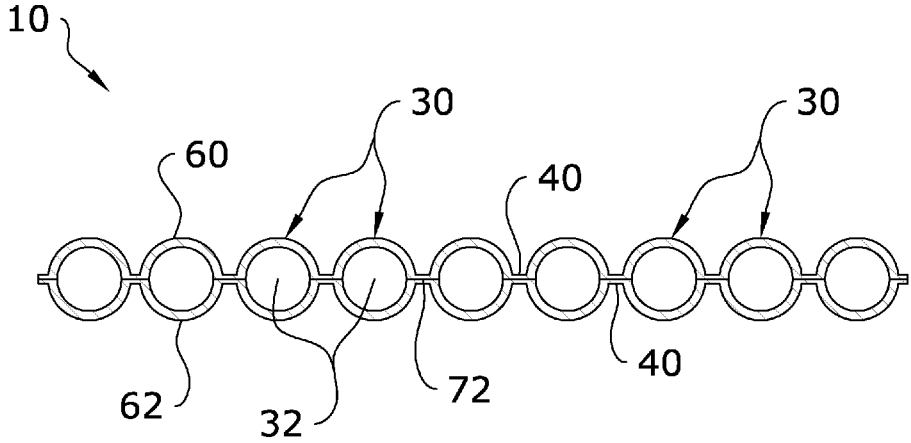

FIG. 12a

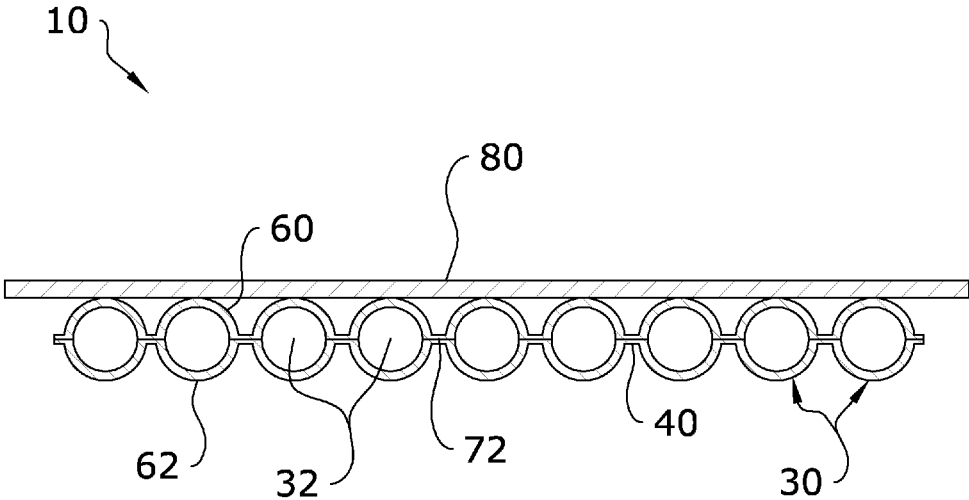

FIG. 12b

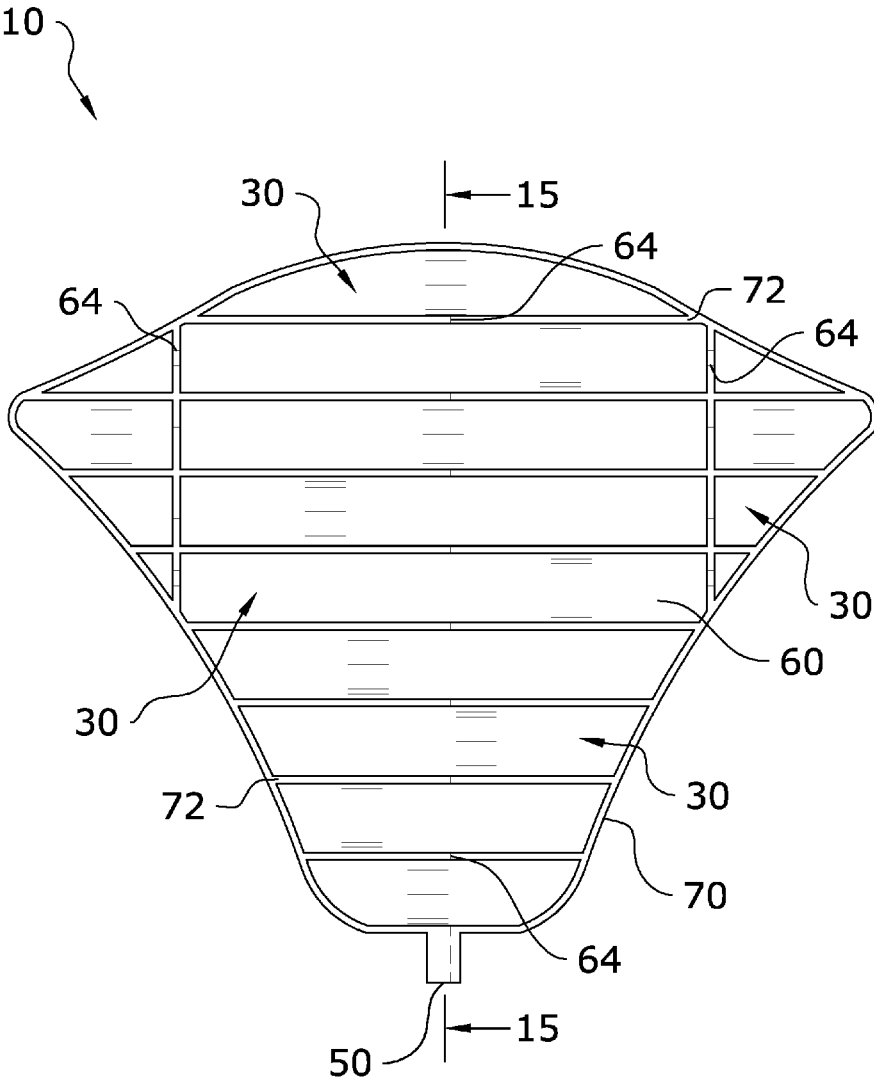

FIG. 13

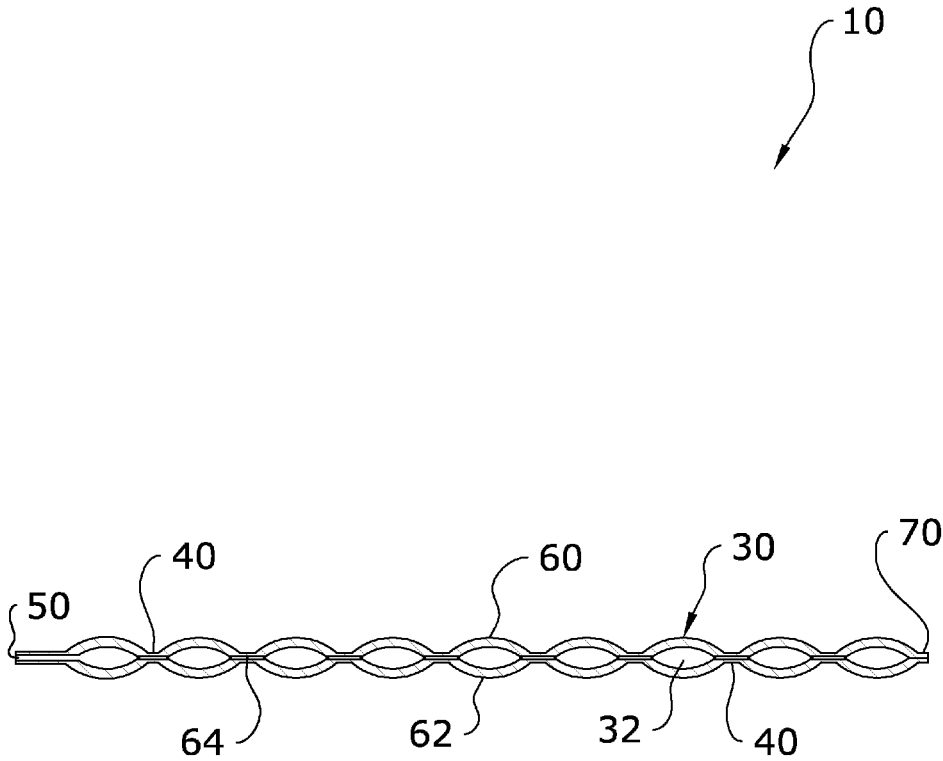

FIG. 14

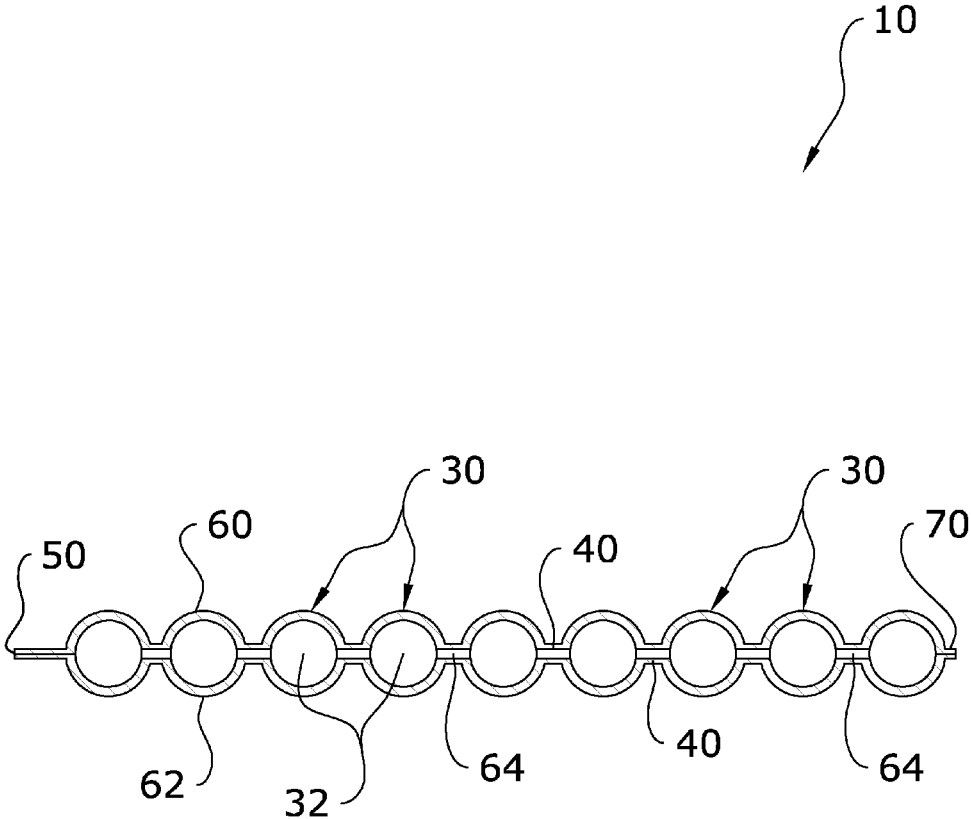

FIG. 15

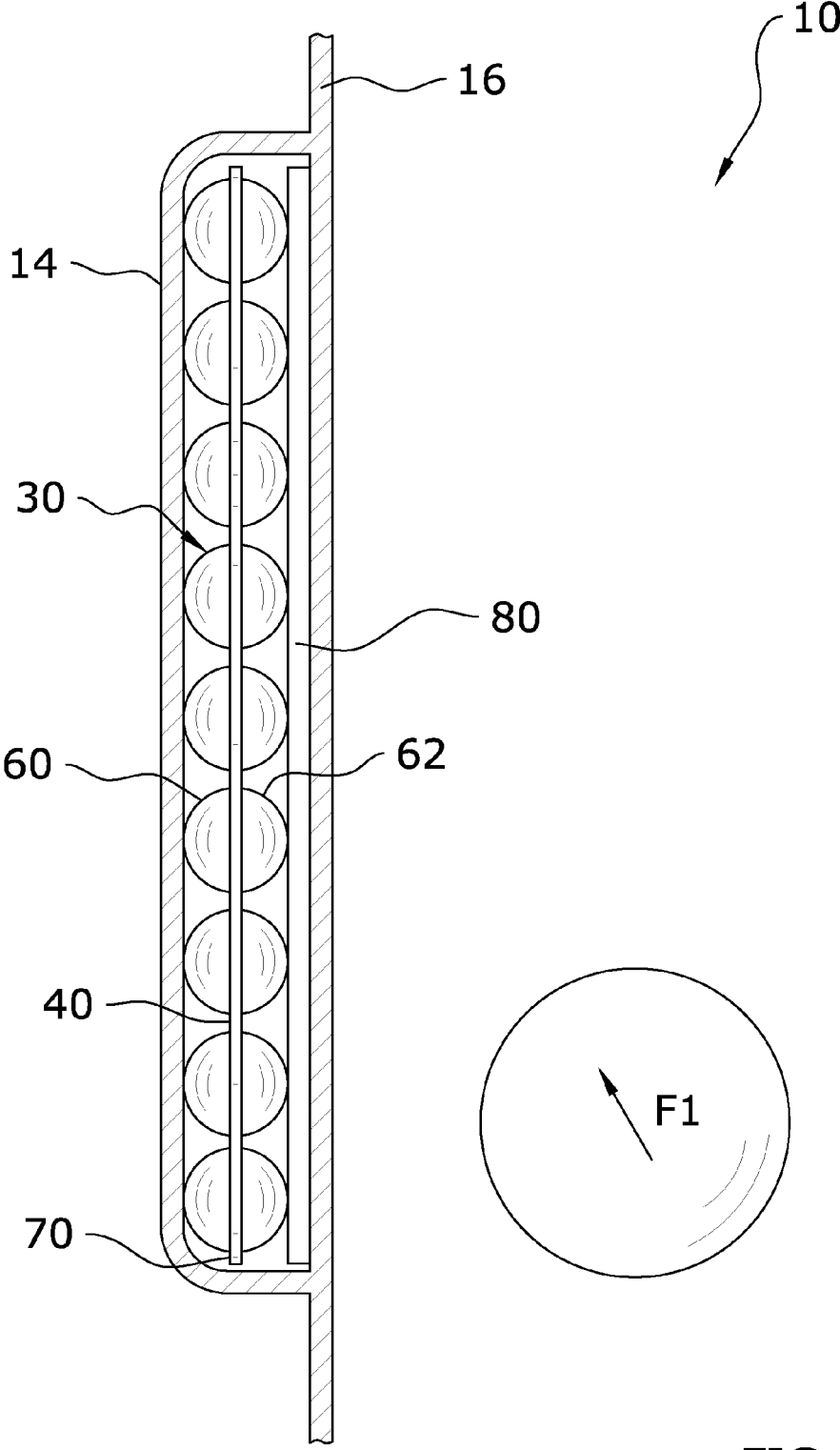

FIG. 16

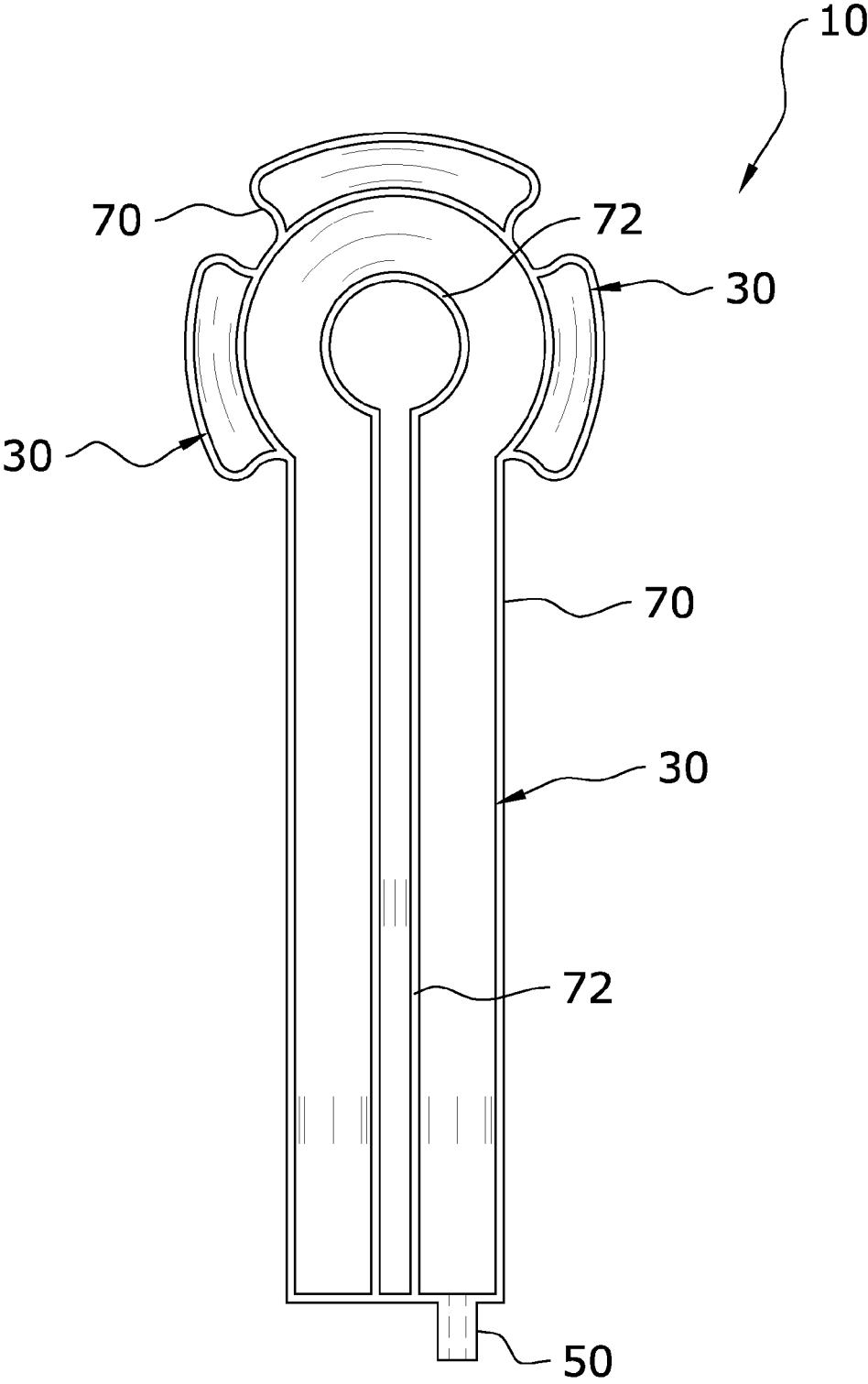

FIG. 17

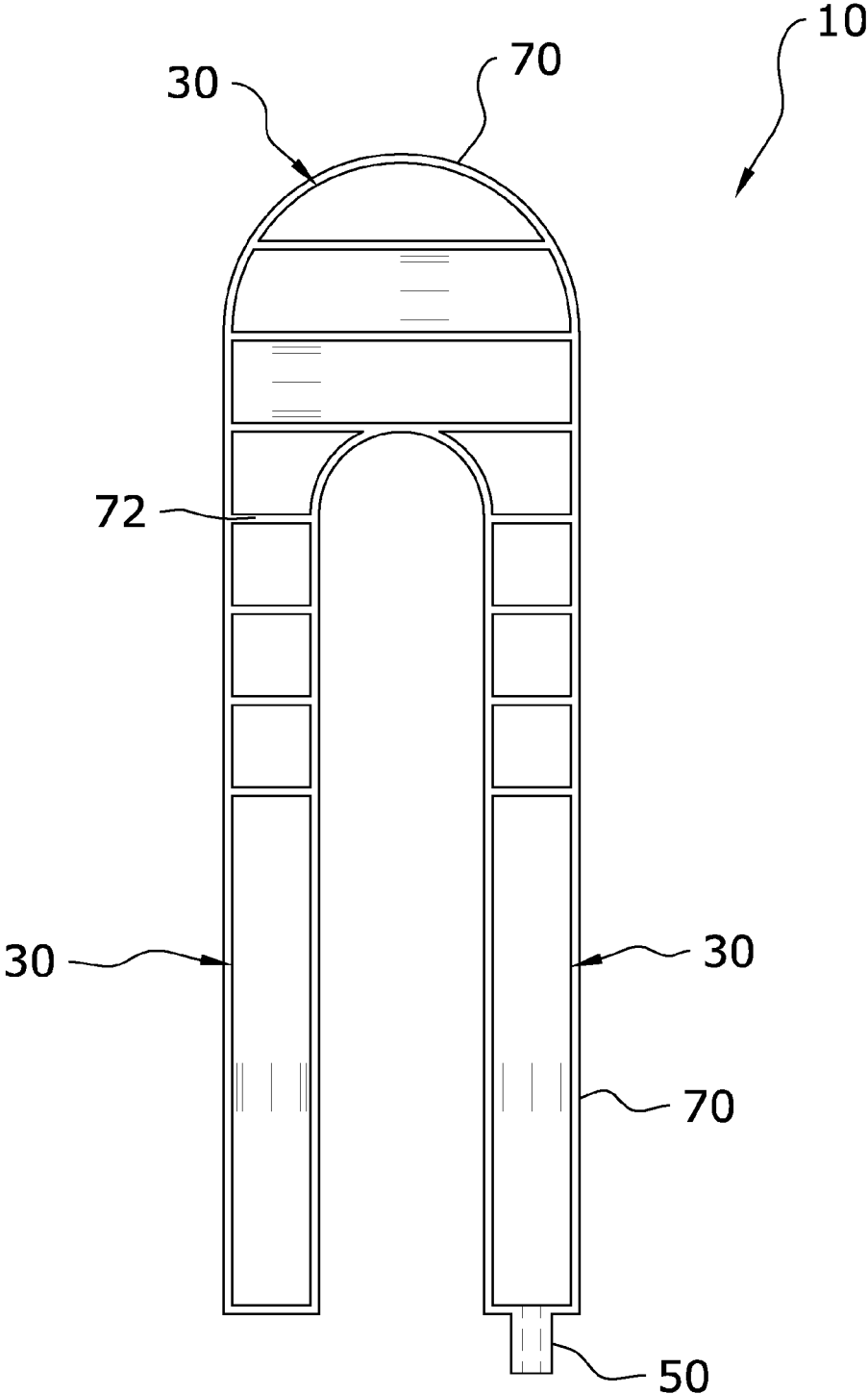

FIG. 18

LIGHTWEIGHT AND FLEXIBLE PROTECTIVE EQUIPMENT SYSTEM

CROSS REFERENCE TO RELATED APPLICATIONS

[0001] I hereby claim benefit under Title 35, United States Code, Section 119(e) of U.S. provisional patent application Ser. No. 61/630,969 filed Dec. 20, 2011. The 61/630,969 application is currently pending. The 61/630,969 application is hereby incorporated by reference into this application.

STATEMENT REGARDING FEDERALLY SPONSORED RESEARCH OR DEVELOPMENT

[0002] Not applicable to this application.

BACKGROUND OF THE INVENTION

[0003] 1. Field of the Invention

[0004] The present invention relates generally to personal protective equipment and more specifically it relates to a lightweight and flexible protective equipment system for effectively protecting a person from injury without significantly limiting their body movement or causing fatigue.

[0005] 2. Description of the Related Art

[0006] Any discussion of the related art throughout the specification should in no way be considered as an admission that such related art is widely known or forms part of common general knowledge in the field.

[0007] Personal protective equipment is utilized to protect individuals from bodily injury in various applications such as but not limited to sports, work, law enforcement and military events. Protective equipment is used by various individuals such as but not limited to athletes, workers, law enforcement personnel, emergency personnel and military personnel. Examples of protective equipment include helmets, shoulder pads, gloves, shoes, thigh pads, knee pads, neck rolls, elbow pads, hip pads, tailbone pads, rib pads, shin pads, forearm guard, wrist guard, abdomen guard, protective vest, bomb suits, motorcycle armor and other protective equipment to be worn by an individual. The purpose of personal protective equipment is to protect the body of the individual from blunt impacts incurred from objects (e.g. hockey puck, baseball, projectile, etc.) or the individual engaging an object (e.g. falling to a ground surface, hitting a wall, etc.).

[0008] Conventional protective equipment is constructed of synthetic materials such as foam rubbers and shock-resistant, molded plastic. The protective equipment is formed into a desired shape to protect the appropriate body region. The protective equipment may be worn externally, internally or within of the clothing (e.g. uniform, jersey, pants, shirt) of an individual. For example, the protective equipment may be worn externally or internally of the clothing utilizing straps or fasteners. The protective equipment may also be inserted into compartments or related structures within the clothing. The protective equipment may also be directly manufactured within the clothing.

[0009] One of the problems with conventional protective equipment is that they are bulky and relatively inflexible. Another problem with conventional protective equipment is that they provide a substantial amount of additional weight to a person which can be fatiguing over time. Another problem with conventional protective equipment is that the foam rub-

ber material can collect fluids over time as they breakdown thereby increasing the weight of the protective padding over time.

[0010] Because of the inherent problems with the related art, there is a need for a new and improved lightweight and flexible protective equipment system for effectively protecting a person from injury without significantly limiting their body movement or causing fatigue.

BRIEF SUMMARY OF THE INVENTION

[0011] The invention generally relates to personal protective equipment which includes protective padding comprised of a plurality of compartments filled with a gas. The compartments are formed utilizing a first membrane attached to a second membrane at selected sealed portions along with a sealed perimeter. The first membrane and the second membrane are comprised of a plastic material capable of incurring significant impacts without rupturing. The protective padding may be covered by a shield to protect the exterior portion of the protective padding. The protective padding may be worn externally, internally or within the clothing of an individual to protect specific portions of the individual's body.

[0012] There has thus been outlined, rather broadly, some of the features of the invention in order that the detailed description thereof may be better understood, and in order that the present contribution to the art may be better appreciated. There are additional features of the invention that will be described hereinafter and that will form the subject matter of the claims appended hereto. In this respect, before explaining at least one embodiment of the invention in detail, it is to be understood that the invention is not limited in its application to the details of construction or to the arrangements of the components set forth in the following description or illustrated in the drawings. The invention is capable of other embodiments and of being practiced and carried out in various ways. Also, it is to be understood that the phraseology and terminology employed herein are for the purpose of the description and should not be regarded as limiting.

BRIEF DESCRIPTION OF THE DRAWINGS

[0013] Various other objects, features and attendant advantages of the present invention will become fully appreciated as the same becomes better understood when considered in conjunction with the accompanying drawings, in which like reference characters designate the same or similar parts throughout the several views, and wherein:

[0014] FIG. 1a is a front upper perspective view illustrating various representative locations for the protective padding.

[0015] FIG. 1b is a rear upper perspective view illustrating various representative locations for the protective padding.

[0016] FIG. 1c is a side view illustrating various representative locations for the protective padding.

[0017] FIG. 2a is a front upper perspective view illustrating various representative locations for the protective padding within clothing.

[0018] FIG. 2b is a rear upper perspective view illustrating various representative locations for the protective padding within clothing.

[0019] FIG. 2c is a side view illustrating various representative locations for the protective padding within clothing.

[0020] FIG. 3a is a top view of the protective padding showing a plurality of rectangular shaped compartments.

[0021] FIG. 3*b* is a top view of the protective padding showing a plurality of triangular shaped compartments.

[0022] FIG. 3*c* is a top view of the protective padding showing a plurality of circular shaped compartments.

[0023] FIG. 4 is a bottom view of the protective padding.

[0024] FIG. 5 is a side view of the protective padding with rectangular shaped compartments.

[0025] FIG. 6*a* is a cross sectional view taken along line 6-6 of FIG. 3*a* illustrating the interior cavity of the compartments filled with a gas.

[0026] FIG. 6*b* is a cross sectional view taken along line 6-6 of FIG. 3*a* illustrating the interior cavity of the compartments filled with a liquid or gel.

[0027] FIG. 7 is a cross sectional view taken along line 7-7 of FIG. 3*a*.

[0028] FIG. 8*a* is a side view of the protective padding positioned adjacent the knee of a user.

[0029] FIG. 8*b* is a side view of the protective padding positioned adjacent the knee of a user with an object approaching with a force F1.

[0030] FIG. 8*c* is a side view of the protective padding positioned adjacent the knee of a user with the object impacting the protective padding with a force F2.

[0031] FIG. 9 is a side cutaway view of the protective padding positioned adjacent the knee of the user and positioned within a receiver structure within clothing.

[0032] FIG. 10*a* is a top view of an alternative embodiment of the present invention wherein the protective padding formed into a shape for protecting the tailbone of a user and wherein the protective padding is formed from a pair of membranes.

[0033] FIG. 10*b* is a top view of a shield positioned above the protective padding.

[0034] FIG. 11*a* is a side view of the alternative embodiment for the protective padding.

[0035] FIG. 11*b* is a side view of the alternative embodiment with the shield positioned above and adjacent to the protective padding.

[0036] FIG. 12*a* is a cross sectional view taken along line 12*a*-12*a* of FIG. 10*a*.

[0037] FIG. 12*b* is a cross sectional view taken along line 12*b*-12*b* of FIG. 10*b*.

[0038] FIG. 13 is a top view of another alternative embodiment with connecting passages between the compartments.

[0039] FIG. 14 is a side cutaway view along line 15-15 of FIG. 13 with the protective padding in a deflated state.

[0040] FIG. 15 is a side cutaway view along line 15-15 of FIG. 13 with the protective padding in an inflated state.

[0041] FIG. 16 is a side cutaway view of the protective padding positioned within a receiver structure of clothing with a shield positioned on the outside portion of the protective padding and an object proceeding towards it.

[0042] FIG. 17 is a top view of an alternative embodiment of the protective padding for usage in a shin guard.

[0043] FIG. 18 is a top view of another alternative embodiment of the protective padding for usage in a shin guard.

DETAILED DESCRIPTION OF THE INVENTION

A. Overview

[0044] Turning now descriptively to the drawings, in which similar reference characters denote similar elements throughout the several views, FIGS. 1 through 18 illustrate a lightweight and flexible protective equipment system, which com-

prises a plurality of compartments 30 filled with a gas. The compartments 30 are formed utilizing a first membrane 60 attached to a second membrane 62 at selected sealed portions 72 along with a sealed perimeter 70. The first membrane 60 and the second membrane 62 are comprised of a plastic material capable of incurring significant impacts without rupturing. The protective padding 10 may be covered by a shield 80 to protect the exterior portion of the protective padding 10. The protective padding 10 may be worn externally, internally or within the clothing 16 of an individual to protect specific portions of the individual's body. The protective padding 10 may be attached to an individual in any manner utilized for conventional padding for individuals. The protective padding 10 is comprised of a material impermeable to gas (e.g. air, helium, etc.). The protective padding 10 may be coated or covered fully or partially with a cut resistant material such as para-aramid synthetic fiber (e.g. KEVLAR®). The protective padding 10 is flexible to allow for conforming to various shapes of the human body and to absorb the impact forces from an object 12.

B. Protective Padding

i. Overview

[0045] FIGS. 1*a* through 2*c* illustrate some exemplary shapes and locations for the protective padding 10 to be utilized upon a human. For example, the protective padding 10 may be utilized to protect the chest, elbows, shins, head and the like of the individual. It can be appreciated that the shape of the protective padding 10 may be similar to or different to the shapes illustrated in FIGS. 1*a* through 2*c* which are for illustration purposes.

ii. First Embodiment

[0046] FIGS. 3*a* through 9 illustrate a first embodiment of the protective padding 10 comprised of a support panel 20 with a plurality of compartments 30 attached to the support panel 20. The support panel 20 is comprised of a flexible material (e.g. plastic, rubber, etc.) and may have various shapes (e.g. rectangular, circular, oval, etc.). The support panel 20 provides for an interconnection of the plurality of compartments 30.

[0047] The plurality of compartments 30 are attached to the interior surface 24 of the support panel 20 in a sealed manner and extend outwardly therefrom as illustrated in FIGS. 5 through 9 of the drawings. The exterior surface 22 of the support panel 20 preferably is positioned outside of the body part to be protected and to be engaged by an object 12 as illustrated in FIGS. 8*a* through 9 of the drawings. As illustrated in FIG. 8*c*, the support panel 20 assists in distributing the force of the object 12 over the plurality of compartments 30. The support panel 20 is preferably elastic thereby allow the stretching and compression of the various locations of the support panel 20 to provide for additional absorption of the forces from the object 12. The surface area of the combined engaging surfaces 34 of the compartments 30 is preferably less than the surface area of the interior surface 24 of the support panel 20 to provide increased ventilation for heat dissipation from the body of the individual.

[0048] Each of the compartments 30 includes an interior cavity 32 that includes one or more sidewalls 36 and an engaging surface 34 as illustrated in FIGS. 3*a* through 9 of the drawings. The compartments 30 are formed from a flexible

and resilient material capable of receiving impacts without rupturing such as plastic, rubber and the like. The compartments 30 and the support panel 20 are preferably comprised of a material that is impermeable to gas to prevent the gas within the interior cavity 32 from escaping and ensuring proper compression of the gas within the compartment 30 when struck by the object 12.

[0049] The compartments 30 may have various shapes such as rectangular (FIG. 3a), triangular (FIG. 3b), circular (3c) and the like. Various combinations of shapes may be utilized for the compartments 30. The compartments 30 may be comprised of the same size or different sizes. The compartments 30 may be aligned in rows and columns as illustrated in FIGS. 3a through 3c of the drawings. The compartments 30 may also be positioned in an unaligned manner upon the support panel 20. FIG. 3a illustrated the usage of compartments 30 having a longer structure for the center rows forming a cross-pattern with the remaining compartments 30 having a shorter structure.

[0050] A plurality of channels 40 extend between the compartments 30 to provide for flexibility of the protective padding 10 and ventilation for the user as illustrated in FIGS. 3a through 9 of the drawings. The channels 40 may be comprised of a grid-pattern or other configuration. The channels 40 preferably exit out the perimeter portion of the support panel 20 to provide for adequate ventilation during usage. The spacing of the channels 40 also is sufficient to allow for flexing of the support panel 20 without the compartments 30 significantly engaging one another as illustrated in FIGS. 8a through 8c of the drawings. The channels 40 may be interconnected or separate from one another. The channels 40 preferably extend to the interior surface 24 of the support panel 20 as illustrated in FIG. 7 of the drawings. The channels 40 are substantially narrower than the width of the compartments 30.

[0051] The compartments 30 are preferably filled with a gas to provide protective padding 10 that is lightweight and flexible. One or all of the compartments 30 are sealed to prevent the escape of the gas from the compartments 30. The gas allows for the absorption of the forces from the object 12 striking the protective padding 10. As illustrated in FIG. 6b, a gel or liquid may alternatively fill the interior cavity 32 of the compartments 30.

iii. Second Embodiment

[0052] FIGS. 10a through 16 illustrate a second embodiment of the present invention wherein the protective padding 10 is comprised of a first membrane 60 connected to a second membrane 62 forming a plurality of compartments 30. U.S. Pat. No. 8,277,910 illustrates an exemplary manufacturing process suitable for producing the protective padding 10 with a plurality of membranes and is hereby incorporated by reference herein.

[0053] The membranes 60, 62 are comprised of a plastic material that is lightweight and flexible. The membranes are further comprised of a material that is thin, such as the material disclosed in U.S. Pat. No. 8,277,910 which is incorporated by reference herein. At least one of the first membrane 60 and the second membrane 62 is comprised of multiple layer coextruded low-density polyethylene film with nylon. It is preferable that the membranes 60, 62 are both comprised of a 7-9 layer coextruded low-density polyethylene film with nylon. The nylon strands are incorporated within the membranes 60, 62 to provide increased strength.

[0054] The protective padding 10 preferably includes a sealed perimeter 70 as illustrated in FIGS. 10a and 13 of the drawings. However, the compartments 30 may be individually sealed without a sealed perimeter 70. The compartments 30 themselves may form a sealed perimeter 70 for the protective padding 10.

[0055] The plurality of compartments 30 formed between the membranes 60, 62 may be separate from one another as illustrated in FIG. 10a of the drawings. Alternatively, two or more of the plurality of compartments 30 may be fluidly connected to one another thereby providing a consistent pressure for the gas within the fluidly connected compartments 30. It is preferable that all of the compartments 30 are fluidly connected to one another to allow for the filling of the compartments 30 with a pressurized gas via the inlet port 50 as illustrated in FIGS. 13 through 15 of the drawings. In addition, the compartments 30 may be fluidly connected in groups or zones within the protective padding 10 (e.g. 3 central compartments 30 connected together, 4 outer compartments 30 connected together).

[0056] One or more sealed portions 72 between the compartments 30 forms the compartments 30 as illustrated in FIGS. 10a through 18 of the drawings. The sealed portions 72 (and the sealed perimeter 70) are comprised of the opposing surfaces of the membranes 60, 62 being attached to one another via a heat sealing method, adhesive or other attachment system. The sealed portions 72 are preferably narrow and form the channels 40 for ventilation and movement of the compartments 30. The sealed portions 72 provide increased flexibility for the protective padding 10 and provide a location for significant pivoting of the protective padding 10 when struck by an object 12. The sealed portions 72 may have various widths but are preferably wide enough to provide sufficient spacing between compartments 30 for ventilation and movement of the compartments 30 with respect to one another.

[0057] The inlet port 50 is fluidly connected to one or more of the plurality of compartments 30 thereby allowing filling of the compartments 30 with the pressurized gas (e.g. air, helium, air plus helium). After the protective padding 10 is filled with the gas so the compartments 30 are at a desired level of firmness, the inlet port 50 is sealed to prevent the escape of the gas. The gas may be inserted into the compartments 30 via the inlet port 50 via various well-known pressurized gas sources (e.g. an air compressor, pressurized helium tank).

[0058] One or more connecting passages 64 fluidly connect at least two of the plurality of compartments 30 as illustrated in FIGS. 13 through 15 of the drawings. The connecting passages 64 are preferably significantly smaller in size than the compartments 30 to prevent the rapid transfer of a gas from one compartment 30 to another when struck by an object 12.

[0059] One or more of the plurality of compartments 30 is preferably comprised of an elongated tubular structure as illustrated in FIGS. 10 through 18 of the drawings. The plurality of compartments 30 may have various cross sectional shapes such as a circular cross sectional shape shown in FIGS. 12a and 12b of the drawings. Each of the compartments 30 may be the same size or different sizes may be utilized as illustrated in FIG. 10a of the drawings. FIGS. 10a, 17 and 18 illustrates exemplary shapes and structures for the protective padding 10 utilizing the membranes 60, 62.

C. Gas

[0060] One or more of the plurality of compartments 30 are filled with a gas. It is preferable that the compartments 30 are all filled with the same type of gas, however, different compartments 30 may utilize different types of gas depending upon the desired compression characteristics. The compression characteristics determine the damping properties created by the increased/decreased hydraulic pressure within the interior cavity 32 of the compartments 30.

[0061] The interior compartment 32 for each of the compartments 30 is filled with a gas to provide a lightweight protective padding 10 for the user. Gas also is compressible providing a desirable level of absorption of force from the impact of an object 12 (e.g. hockey puck, baseball, weapon, floor, wall, etc.). The usage of gas within the compartments 30 also ensures a consistent absorption of the force from an object 12 over time without becoming hardened or compressed over time like foam rubber can.

[0062] The compartments 30 are preferably filled with air, a combination of air and helium, or helium. Various other gases may be inserted into the interior cavity 32 for each of the compartments 30. In addition, the gas is preferably comprised of a pressurized gas having a pressure greater than external atmospheric pressure, however, the gas may have the same or substantially the same pressure as the external atmosphere.

D. Shield

[0063] The protective padding 10 may be utilized by itself for protecting an individual or in combination with a shield 80 positioned adjacent to an exterior surface 22 of the protective padding 10. FIGS. 10b and 11b illustrate an exemplary shield 80 that is shaped similar to the shape of the protective padding 10. The exemplary shield 80 preferably is slightly larger than the protective padding 10 and provides a structure that distributes the forces throughout the plurality of compartments 30 to prevent damage to one or more of the compartments 30.

[0064] The shield 80 is comprised of a material having a rigidity substantially greater than the protective padding 10. The shield 80 may be resilient and flexible, or the shield 80 may be rigid in structure. The shield 80 is preferably comprised of a flat structure as illustrated in FIG. 11 of the drawings, however, the shield 80 may be comprised of a configuration having openings, support ribs and the like. The shield 80 may also be formed to various shapes (e.g. shin guards, curved, planar, etc.) to conform to the shape of the human body part to be protected. The shield 80 may be comprised of various materials such as but not limited to plastic (e.g. ABS plastic, polypropylene, polyethylene, etc.), composite materials, metal and the like.

[0065] The shield 80 may be attached to the protective padding 10 utilizing various types of connection devices such as but not limited to fasteners, straps, adhesive, welding and the like. The shield 80 may also be positioned adjacent to the protective padding 10 without direct attachment such as within the receiver structure 14 (e.g. a pocket) within the clothing 16 worn by the individual as illustrated in FIG. 16 of the drawings. The shield 80 is preferably positioned on the side of the protective padding 10 opposite of the individual as illustrated in FIG. 16, however, the shield 80 may alternatively be positioned between the individual and the protective padding 10. More than one shield 80 may also be utilized wherein the shields 80 may be positioned near one another and/or attached to one another. Utilizing a plurality of shields

80 connected together provides for articulation of the shield 80 along with the articulation of the protective padding 10.

E. Usage of Invention

[0066] The compartments 30 may be initially pressurized with gas (FIG. 15) or deflated (FIG. 14). If the compartments 30 are initially deflated, the user may ship the protective padding 10 in a compact manner thereby reducing shipping costs. In addition, when the protective padding 10 is deflated, the protective padding 10 is easier to insert into a receiver structure 14 (e.g. pocket, vest, etc.) during the manufacturing process. After the deflated protective padding 10 is inserted into the receiver structure 14 of the clothing 16, pressurized gas is input into the inlet port 50 thereby filling the fluidly connected compartments 30. More than one inlet port 50 may be utilized if a plurality of zones for the compartments 30 are used (i.e. one inlet port 50 for each zone of compartments 30). After the compartments 30 are filled with the pressurized gas to a desired pressure level, the user then removes the pressurized gas source and immediately seals the inlet port 50 to prevent the escape of the gas. A shield 80 may be positioned within the receiver structure 14 adjacent to the protective padding 10 as illustrated in FIG. 16 of the drawings. The receiver structure 14 may be closed or otherwise secured to prevent the accidental removal or movement of the protective padding 10 within. The individual then wears the protective padding 10 (e.g. on their knee 18) similar to conventional padding used today.

[0067] When an object 12 strikes the shield 80 or the protective padding 10 directly, one or more of the compartments 30 are compressed by the force F1 of the object 12 with the remaining force F2 which is the energy not absorbed by the protective padding 10 as illustrated in FIG. 8c of the drawings. The gas within the compartments 30 is compressed based upon the location of the force from the object 12. The greater the force F2 of the object 12, the more the gas will be compressed within the respective compartments 30 until the force applied outwardly by the protective padding 10 equals the force of the object 12 thereby stopping the movement of the object 12 towards the user. The force is distributed through the area of the protective padding 10 thereby preventing injury to the user. In addition, when the user moves their body the channels 40 between the compartments 30 allows for the free movement of the body part without obstruction.

[0068] Unless otherwise defined, all technical and scientific terms used herein have the same meaning as commonly understood by one of ordinary skill in the art to which this invention belongs. Although methods and materials similar to or equivalent to those described herein can be used in the practice or testing of the present invention, suitable methods and materials are described above. All publications, patent applications, patents, and other references mentioned herein are incorporated by reference in their entirety to the extent allowed by applicable law and regulations. In case of conflict, the present specification, including definitions, will control. The present invention may be embodied in other specific forms without departing from the spirit or essential attributes thereof, and it is therefore desired that the present embodiment be considered in all respects as illustrative and not restrictive. Any headings utilized within the description are for convenience only and have no legal or limiting effect.

The invention claimed is:

1. A personal protective padding for protecting an individual from injury, comprising:

- a protective padding including a plurality of compartments;
wherein said plurality of compartments are filled with a gas;
wherein said protective padding is comprised of a material impermeable to gas.
2. The personal protective padding of claim 1, wherein said gas is comprised of air.
3. The personal protective padding of claim 1, wherein said gas includes helium.
4. The personal protective padding of claim 1, wherein said gas is comprised of a pressurized gas.
5. The personal protective padding of claim 1, wherein said protective padding includes a sealed perimeter.
6. The personal protective padding of claim 1, wherein said plurality of compartments are comprised of at least two different sizes.
7. The personal protective padding of claim 1, wherein said protective padding is comprised of a first membrane connected to a second membrane forming said plurality of compartments.
8. The personal protective padding of claim 7, wherein said protective padding includes an inlet port fluidly connected to one of said plurality of compartments.
9. The personal protective padding of claim 8, wherein two or more of said plurality of compartments are fluidly connected to one another.
10. The personal protective padding of claim 8, including a connecting passage fluidly connecting at least two of said plurality of compartments.
11. The personal protective padding of claim 8, wherein all of said plurality of compartments are fluidly connected to one another.
12. The personal protective padding of claim 1, wherein at least one of said plurality of compartments is comprised of an elongated tubular structure.
13. The personal protective padding of claim 12, wherein more than one of said plurality of compartments is comprised of an elongated tubular structure.
14. The personal protective padding of claim 12, wherein all of said plurality of compartments is comprised of an elongated tubular structure.
15. The personal protective padding of claim 1, wherein said plurality of compartments have a circular cross sectional shape.
16. The personal protective padding of claim 1, wherein said plurality of compartments have a rectangular cross sectional shape.
17. A personal protective padding for protecting an individual from injury, comprising:
a protective padding comprised of a first membrane connected to a second membrane forming a plurality of compartments;
wherein said plurality of compartments are filled with a gas;
wherein said protective padding is comprised of a material impermeable to gas.
18. The personal protective padding of claim 17, wherein at least one of said first membrane and said second membrane is comprised of low-density polyethylene.
19. The personal protective padding of claim 17, wherein at least one of said first membrane and said second membrane is comprised of multiple layer coextruded low-density polyethylene film with nylon.
20. A personal protective padding for protecting an individual from injury, comprising:
a protective padding comprised of a first membrane connected to a second membrane forming a plurality of compartments;
wherein said plurality of compartments are filled with a gas;
wherein said protective padding is comprised of a material impermeable to gas;
wherein at least one of said first membrane and said second membrane is comprised of multiple layer coextruded low-density polyethylene film with nylon;
wherein two or more of said plurality of compartments are fluidly connected to one another;
wherein at least one of said plurality of compartments is comprised of an elongated tubular structure; and
a shield positioned adjacent to an exterior surface of said protective padding, wherein said shield is comprised of a material having a rigidity substantially greater than said protective padding.

* * * * *