



(19) **United States**

(12) **Patent Application Publication**
Schuck et al.

(10) **Pub. No.: US 2013/0169935 A1**

(43) **Pub. Date: Jul. 4, 2013**

(54) **POLARIZATION CONVERSION SYSTEMS FOR STEREOSCOPIC PROJECTION**

Publication Classification

(75) Inventors: **Miller H. Schuck**, Erie, CO (US);
Michael G. Robinson, Boulder, CO (US);
Gary D. Sharp, Boulder, CO (US)

(51) **Int. Cl.**
G02B 27/26 (2006.01)
G02B 27/28 (2006.01)
(52) **U.S. Cl.**
CPC **G02B 27/26** (2013.01); **G02B 27/283** (2013.01)
USPC **353/8**; 359/489.08; 353/20

(73) Assignee: **REALD INC.**, Beverly Hillds, CA (US)

(57) **ABSTRACT**

(21) Appl. No.: **13/550,182**

A polarization conversion system (PCS) is located in the output light path of a projector. The PCS may include a polarizing beam splitter, a polarization rotating element, a reflecting element, and a polarization switch. Typically, a projector outputs randomly-polarized light. This light is input to the PCS, in which the PCS separates p-polarized light and s-polarized light at the polarizing beam splitter. P-polarized light is directed toward the polarization switch on a first path. The s-polarized light is passed on a second path through the polarization rotating element (e.g., a half-wave plate), thereby transforming it to p-polarized light. A reflecting element directs the transformed polarized light (now p-polarized) along the second path toward the polarization switch. The first and second light paths are ultimately directed toward a projection screen to collectively form a brighter screen image in cinematic applications utilizing polarized light for three-dimensional viewing.

(22) Filed: **Jul. 16, 2012**

Related U.S. Application Data

- (63) Continuation of application No. 13/047,763, filed on Mar. 14, 2011, now Pat. No. 8,220,934, which is a continuation of application No. 11/864,198, filed on Sep. 28, 2007, now Pat. No. 7,905,602.
- (60) Provisional application No. 60/950,652, filed on Jul. 19, 2007, provisional application No. 60/911,043, filed on Apr. 10, 2007, provisional application No. 60/827,657, filed on Sep. 29, 2006.

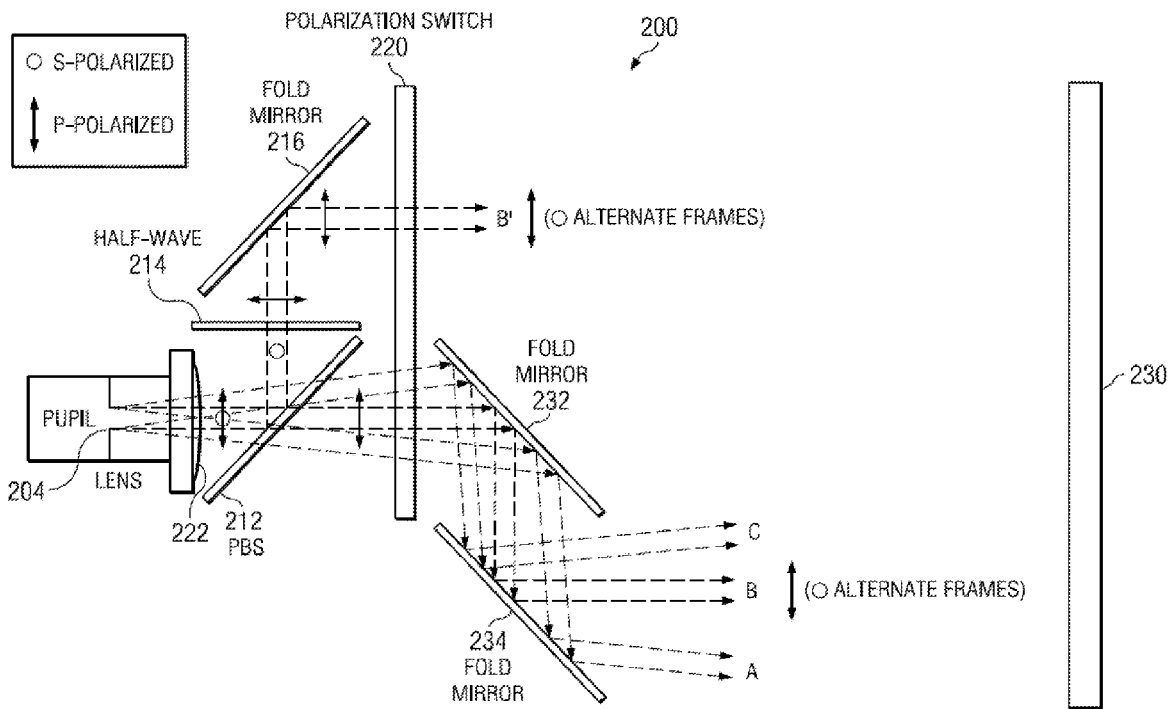

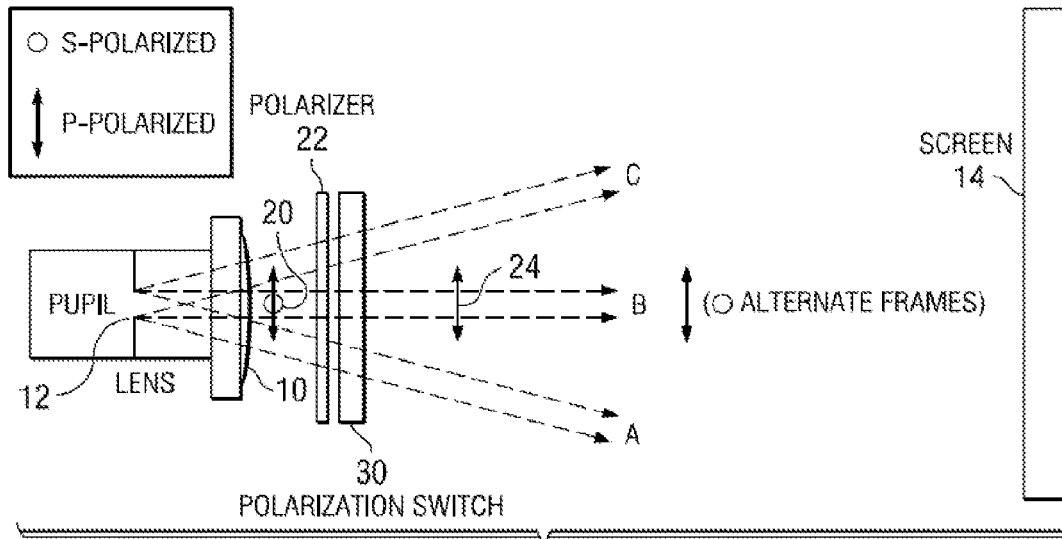

FIG. 1
 (PRIOR ART)

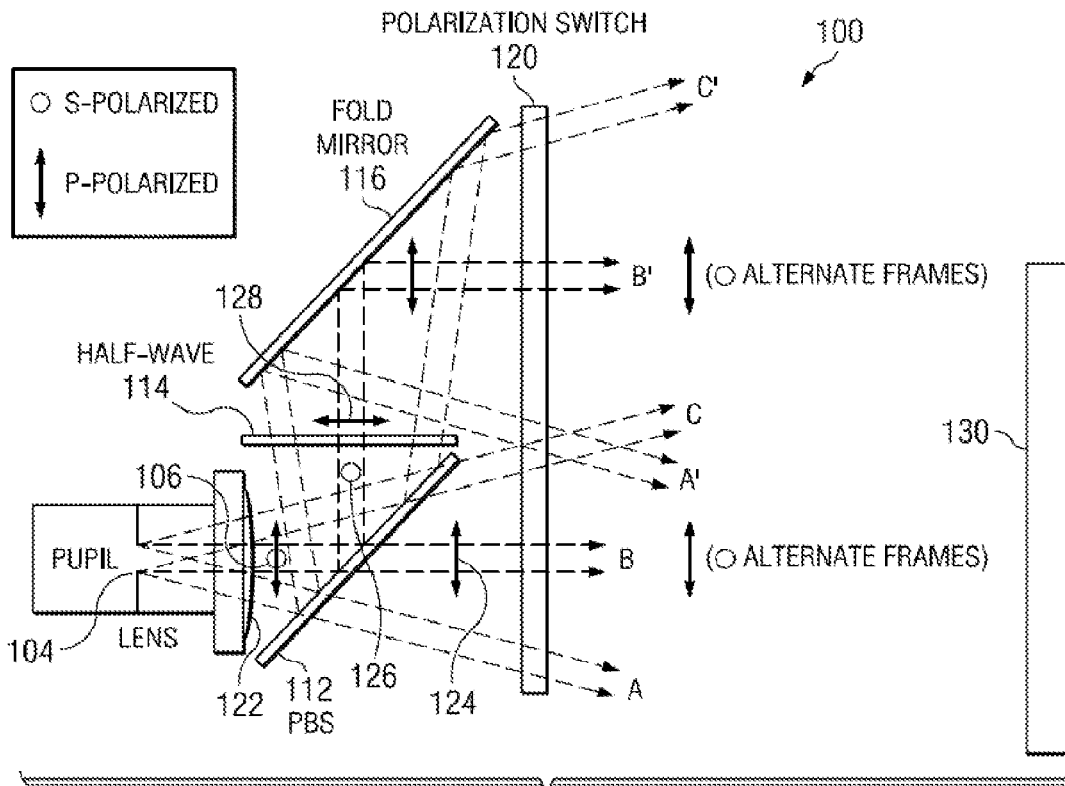

FIG. 2

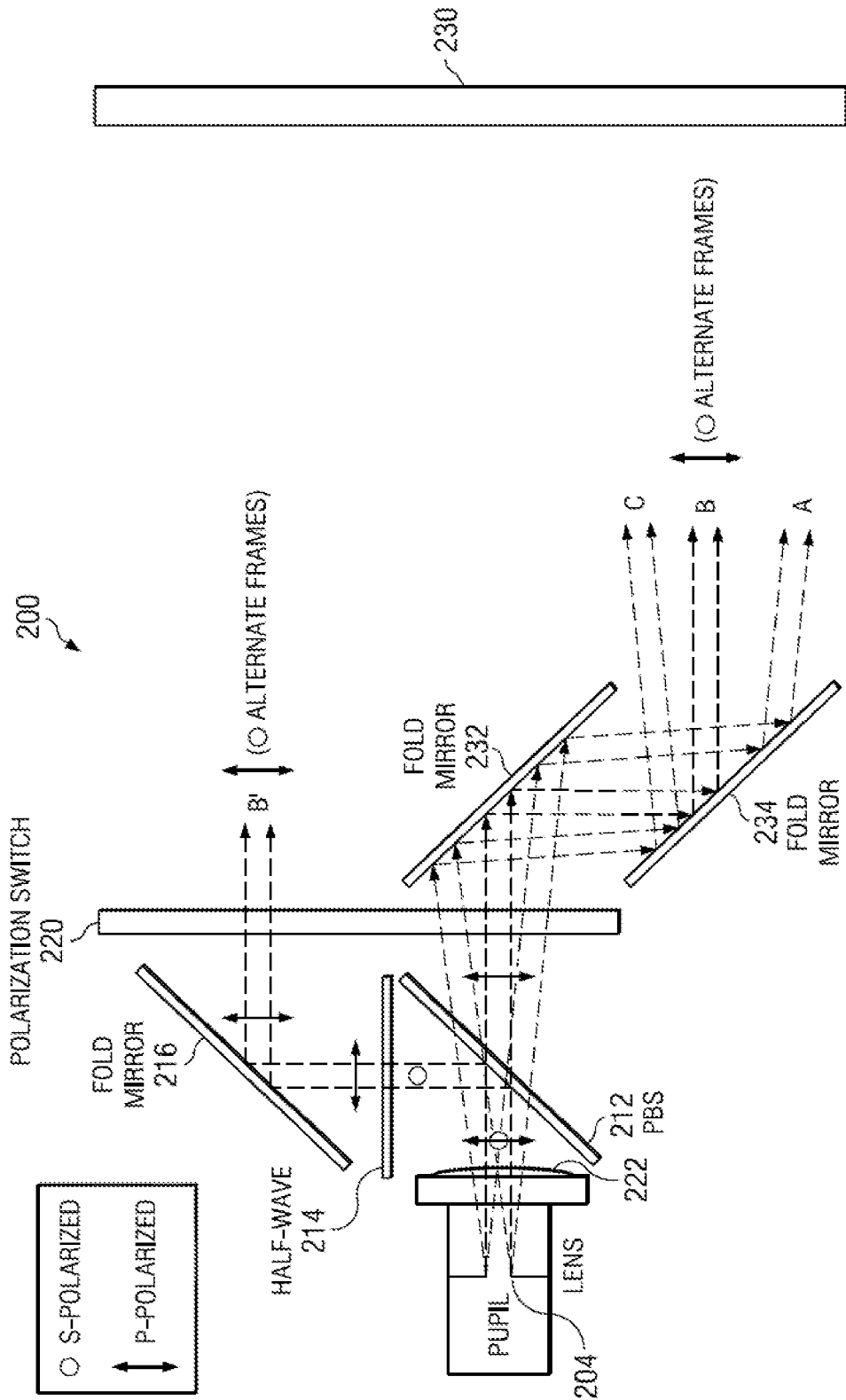

FIG. 3

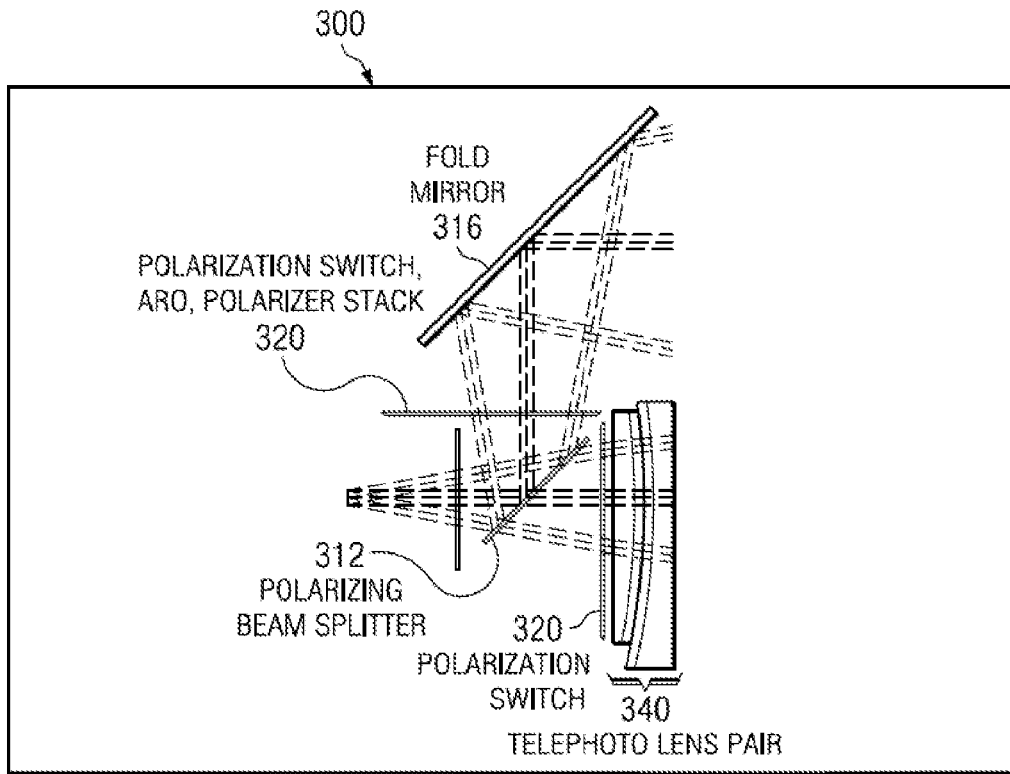

FIG. 4

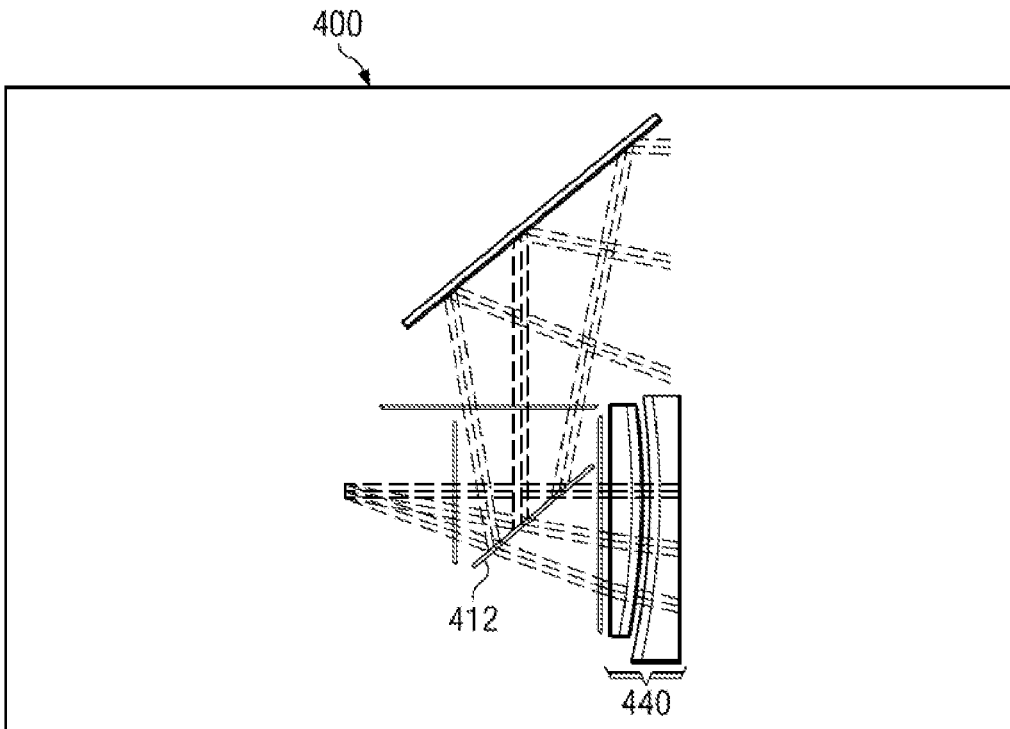

FIG. 5

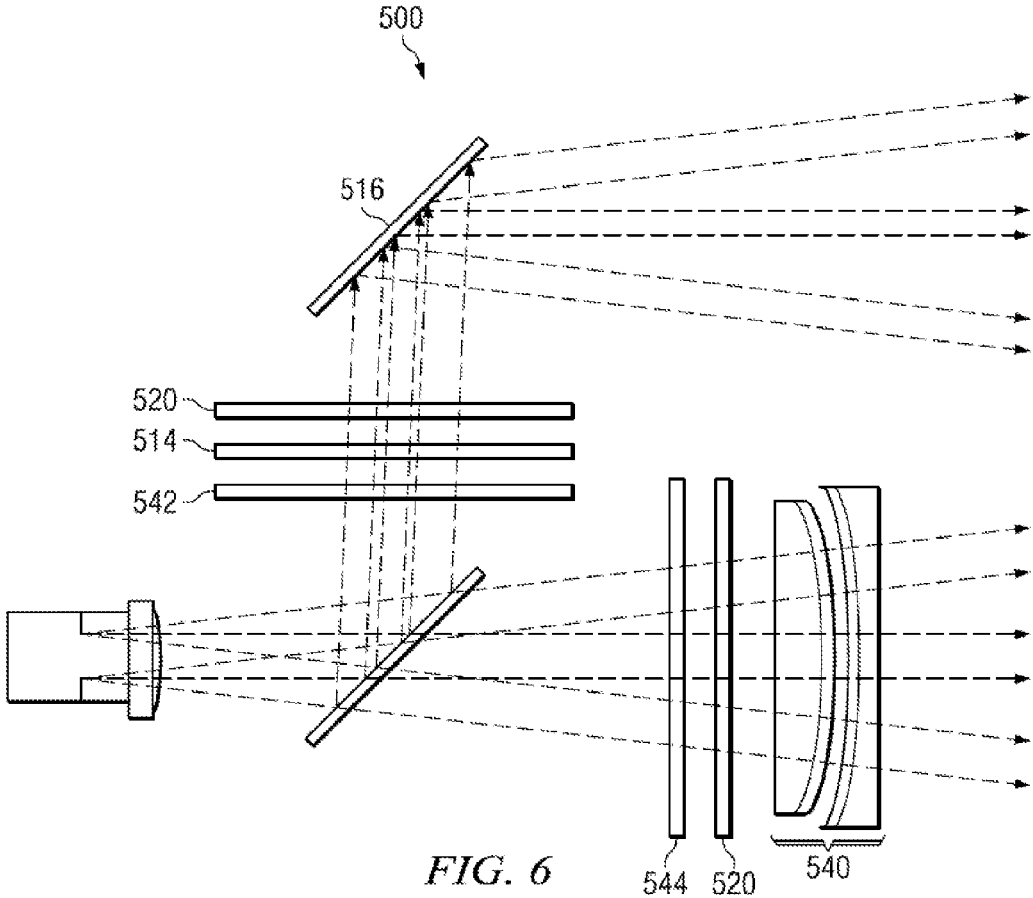

FIG. 6

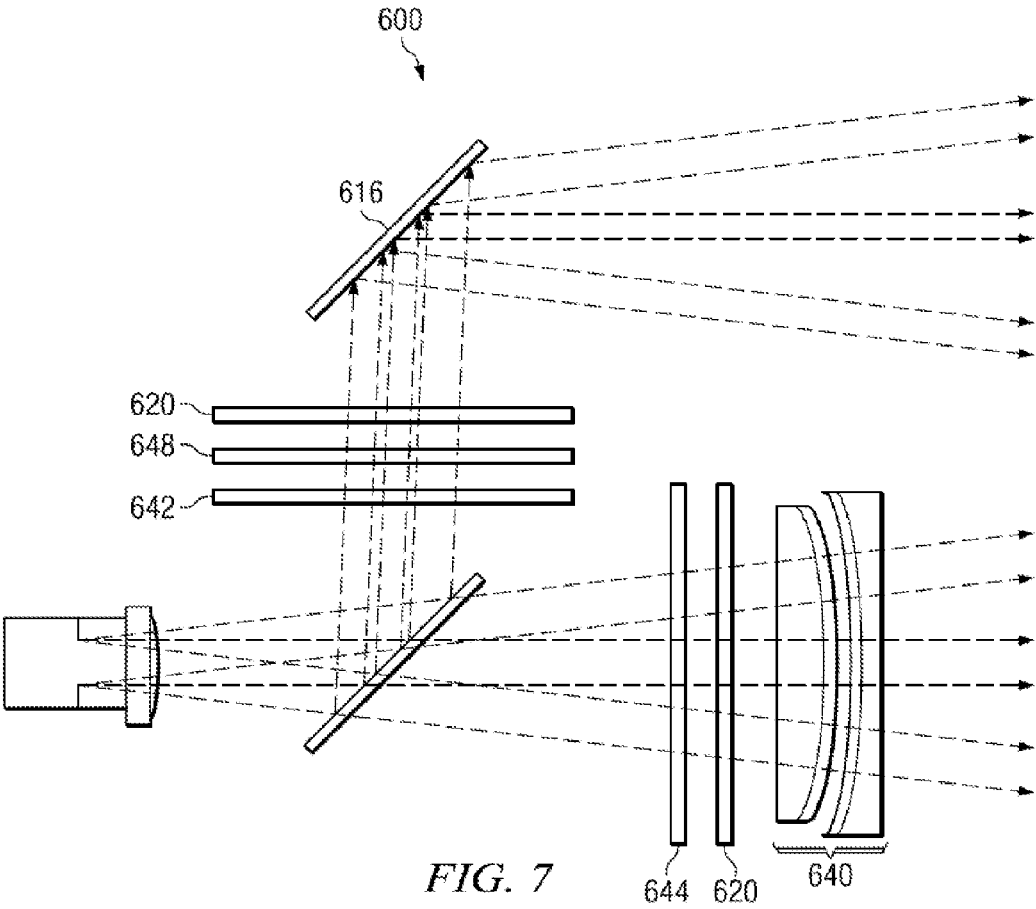

FIG. 7

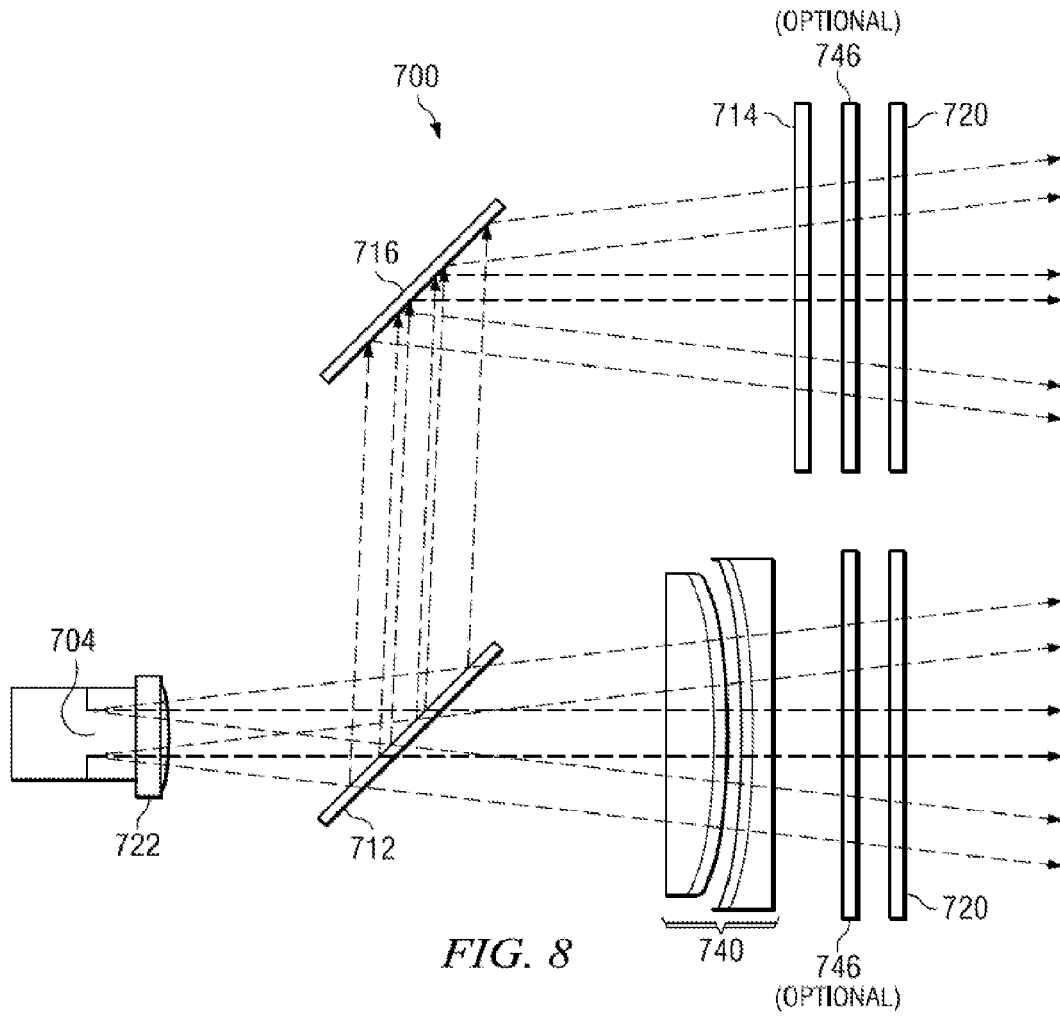

FIG. 8

POLARIZATION CONVERSION SYSTEMS FOR STEREOSCOPIC PROJECTION

CROSS-REFERENCE TO RELATED APPLICATIONS

[0001] This patent application is a continuation application of and claims priority to U.S. patent application Ser. No. 13/047,763, entitled “Polarization conversion systems for stereoscopic projection,” filed Mar. 14, 2011 that is a continuation application of U.S. patent application Ser. No. 11/864,198 entitled “Polarization conversion systems for stereoscopic projection,” filed Sep. 28, 2007, now U.S. Pat. No. 7,905,602 which relates and claims benefit of: (a) U.S. provisional patent application No. 60/827,657, entitled “Polarization Conversion System for Cinematic Projection,” filed Sep. 29, 2006; (b) U.S. provisional patent application No. 60/911,043, entitled “Polarization conversion system for 3-D projection,” filed Apr. 10, 2007; and (c) provisional patent application No. 60/950,652, entitled “Polarization conversion system for 3-D projection,” filed Jul. 19, 2007. All applications referenced above are incorporated by reference.

TECHNICAL FIELD

[0002] This disclosure relates to a projection system for projecting images for a three-dimensional viewing experience, and more in particular to a polarization conversion system utilizing polarized light for encoding stereoscopic images.

BACKGROUND

[0003] Three-dimensional (3D) imagery can be synthesized using polarization control following the projector and polarization controlling eyewear (see, e.g., U.S. Pat. No. 4,792,850 to Lipton, which is hereby incorporated by reference herein).

[0004] A conventional implementation of polarization control at the projector is shown in FIG. 1. In this implementation, nearly parallel rays emerge from the output of the lens 10, appearing to originate from a pupil 12 inside of the lens 10, and converge to form spots on a screen 14. Ray bundles A, B, and C in FIG. 1 are bundles forming spots at the bottom, center, and top of a screen 14, respectively. The light 20 emerging from the projection lens is randomly polarized, depicted in FIG. 1 as both s- and p-polarized light [s-polarized light is conventionally represented as ‘o’; p-polarized light is represented with a double arrow-ended line]. The light 20 passes through a linear polarizer 22, resulting in a single polarization state after the polarizer 22. The orthogonal polarization state is absorbed (or reflected), and the light flux after the polarizer 22 is typically less than half of the original flux, thus resulting in a dimmer final image. The polarization switch 30 is synchronized with the image frame, and the polarization state 24 emerging from the polarization switch is alternated, producing images of alternately orthogonal polarization at the screen. Polarization-selective eyewear allows images of one polarization to pass to the left eye, and images of the orthogonal polarization to pass to the right eye. By presenting different images to each eye, 3D imagery can be synthesized.

[0005] This conventional system has been used in theatres. However, the conventional system requires that greater than 50% of the light is absorbed by the polarizer, and the resulting image is greater than 50% dimmer than that of a typical 2D

theatre. The dimmer image can limit the size of theatre used for 3D applications and/or provides a less desirable viewing experience for the audience.

SUMMARY

[0006] Addressing the aforementioned problems, various embodiments of polarization conversion systems that receive light from a projector are described. The polarization conversion systems present a brighter screen image in cinematic applications utilizing polarized light for three-dimensional viewing.

[0007] In an embodiment, a polarization conversion system includes a polarization beam splitter (PBS), a polarization rotator, and a polarization switch. The PBS is operable to receive randomly-polarized light bundles from a projector lens, and direct first light bundles having a first state of polarization (SOP) along a first light path. The PBS is also operable to direct second light bundles having a second SOP along a second light path. The polarization rotator is located on the second light path, and is operable to translate the second SOP to the first SOP. The polarization switch is operable to receive first and second light bundles from the first and second light paths respectively, and to selectively translate the polarization states of the first and second light bundles to one of a first output SOP and a second output SOP. First light bundles are transmitted toward a projection screen. A reflecting element may be located in the second light path to direct second light bundles toward a projection screen such that the first and second light bundles substantially overlap to form a brighter screen image.

[0008] In accordance with another aspect of the disclosure, a method for stereoscopic image projection includes receiving randomly-polarized light from a projector, directing first state of polarization (SOP) light on a first light path, and directing second SOP light on a second light path. The method also includes transforming the second SOP light on the second light path to first SOP light, and selectively translating the first SOP light on both light paths to one of a first output SOP and a second output SOP.

[0009] Other aspects and embodiments are described below in the detailed description.

BRIEF DESCRIPTION OF THE DRAWINGS

[0010] FIG. 1 is a schematic diagram of a conventional polarization switch for stereoscopic projection;

[0011] FIG. 2 is a schematic diagram of a polarization conversion system (PCS) for cinematic projection in accordance with the present disclosure;

[0012] FIG. 3 is a schematic diagram of another embodiment of a PCS for cinematic projection in accordance with the present disclosure;

[0013] FIG. 4 is a schematic diagram of another embodiment of a PCS for cinematic projection, including a telephoto lens along an optical path and with the field of view centered on the optical axis, in accordance with the present disclosure;

[0014] FIG. 5 is a schematic diagram of another embodiment of a PCS for cinematic projection, including a telephoto lens along an optical path and with the field of view not centered on the optical axis, in accordance with the present disclosure;

[0015] FIG. 6 is a schematic diagram of another embodiment of a PCS for cinematic projection to provide a circularly-polarized output, including a telephoto lens along an

optical path and with field of view centered on an optical axis, in accordance with the present disclosure;

[0016] FIG. 7 is a schematic diagram of another embodiment of a PCS for cinematic projection to provide a linearly-polarized output, including a telephoto lens along an optical path and with field of view centered on an optical axis, in accordance with the present disclosure; and

[0017] FIG. 8 is a schematic diagram of another embodiment of a PCS for cinematic projection in accordance with the present disclosure.

DESCRIPTION

[0018] Various embodiments of polarization conversion systems that receive light from a projector are described. The polarization conversion systems present a brighter screen image in cinematic applications utilizing polarized light for three-dimensional viewing.

[0019] FIG. 2 is a schematic diagram showing a polarization conversion system (PCS) 100 for cinematic projection. An embodiment of the polarization conversion system 100 includes a polarizing beam splitter (PBS) 112, a polarization rotator 114 (e.g., a half-wave plate), a reflecting element 116 (e.g., a fold mirror), and a polarization switch 120, arranged as shown. The polarization conversion system 100 may receive images from a conventional projector with a projection lens 122.

[0020] In operation, ray bundles A, B, and C emerge randomly polarized from the lens 122 and are projected toward a screen 130 to form an image. In this embodiment, a PBS 112 is inserted in place of the polarizer 22 shown in FIG. 1. The PBS 112 transmits P-polarized light 124, and reflects S-polarized light 126. The P-polarized light 124 passes through the polarization switch (bundles A, B, and C) and is rotated by the polarization switch in alternating frames, same as bundles A, B, and C in FIG. 1.

[0021] The S-polarized light 126 reflected by the PBS 112 passes through a polarization rotator 114 (e.g., a half-wave plate, preferably achromatic in some embodiments) and is rotated to p-polarized light 128. The new p-polarized light 128 passes to a fold mirror 116. The fold mirror 116 reflects the new p-polarized light 128 and passes it to polarization switch 120. The polarization switch 120, acting on p-polarized ray bundles A', B', and C', rotates the polarization of the ray bundles in alternating frames, in synchronization with the rotation of bundles A, B, and C. The position of bundles A', B', and C' at the screen may be adjusted (e.g., by adjusting the tilt of the fold mirror 116) to closely or exactly coincide with the positions of bundles A, B, and C at the screen. Since nearly all of the randomly polarized light 106 from the projection lens 122 is imaged at the screen 130 with a single polarization state, the resulting image of the system in FIG. 2 is approximately two times brighter than the image at the screen for the system in FIG. 1.

[0022] In this exemplary embodiment, the PBS 112 in FIG. 2 is depicted as a plate. However, various types of PBSS may be used. For example, the PBS plate may be constructed using a wire grid layer on glass (e.g., Proflux polarizer from Moxtek in Orem, Utah), polarization recycling film (e.g., Double Brightness Enhancing Film from 3M in St. Paul, Minn.), polarization recycling film on glass (for flatness), or a multi-dielectric layer on glass. The PBS 112 in FIG. 2 could alternatively be implemented as a glass cube (with wire grid, polarization recycling film, or dielectric layers along the diagonal) to reduce astigmatism in the final image associated

with light passing through a tilted plate. Alternatively, the tilted plate PBS 112 in FIG. 2 may, in various embodiments, be implemented with spherical, aspheric, cylindrical or toroidal surfaces to reduce astigmatism in the final image at the screen 130. De-centered spherical, aspheric, cylindrical or toroidal surfaces on the plate, and/or additional de-centered spherical, aspheric, cylindrical or toroidal elements in the optical path after the plate can be implemented to reduce astigmatism in the final image. See, e.g., "Simple method of correcting the aberrations of a beamsplitter in converging light," V. Doherty and D. Shafer, Proc. SPIE, Vol. 0237, pp. 195-200, 1980, which is hereby incorporated by reference. It should also be noted that a second flat plate may be inserted into the system after the tilted PBS plate 112 and its tilt adjusted to reduce or correct astigmatism in the final image.

[0023] In some embodiments, the polarization rotator 114 in FIG. 2 may be an achromatic half-wave plate. The half-wave plate may be implemented with polymer films (e.g., Achromatic Retardation Plate from ColorLink, Inc., Boulder, Colo.), quartz plates, or a static liquid crystal device optionally patterned to account for geometric polarization alteration. The half-wave plate 114 may be positioned as shown in FIG. 2, or in other embodiments, it may be positioned between the fold mirror 116 and polarization switch 120, intersecting ray bundles A', B', and C'. This implementation may be desirable, as bundles A', B', and C' reflect from the fold mirror 116 in s-polarization state and mirrors often have a higher reflection for s-polarized light. However, with such an implementation, the half-wave plate 114 should be located such that bundles A' and C' do not overlap at the plate. Although in most described embodiments herein, the polarization rotator 114 is located in the second light path, it may alternatively be placed in the first light path instead, and the polarization conversion system will operate in a similar manner in accordance with the principles of the present disclosure.

[0024] In some embodiments, the fold mirror 116 may be replaced with a PBS element (e.g., wire grid plate). In this case, a purer polarization may be maintained after the PBS element.

[0025] Polarization switch 120 may be a switch as taught by U.S. Pat. No. 4,792,850; a switch as taught by any of the switches of commonly-assigned U.S. patent application Ser. No. 11/424,087 entitled "Achromatic Polarization Switches", filed Jun. 14, 2006; both of which are incorporated by reference in their entirety for all purposes, or any other polarization switch known in the art that selectively transforms an incoming state of polarization. In some embodiments, the polarization switch 120 can be split (i.e., to increase yield of the device). If the polarization switch 120 is split, it is desirable that the two devices are located such that there is no overlap of bundles A' and C' in FIG. 2. Splitting the polarization switch 120 allows one portion to be relocated in the A', B', C' optical path between the half-wave plate 114 and fold mirror 116. Placing the polarization switch 120 here may call for the fold mirror 116 to have better polarization preserving properties (e.g., a Silflex coating from Oerlikon in Golden, Colo.) as this may be the last element in the A', B', C' optical path prior to the screen.

[0026] In the polarization conversion system 100 of FIG. 2, the optical path of ray bundle A' is longer than that of ray bundle A (similarly B'–B and C'–C) resulting in a magnification difference between the images produced by A', B', C' and A, B, C. This magnification difference may be unacceptable

to an audience, especially for wide angle and short-throw projection systems. Some techniques for correcting this magnification difference may include (1) providing a curved surface on the fold mirror **116** with optical power that compensates for the magnification difference; this solution is achromatic, which is desirable; (2) adding a fresnel or diffractive surface with optical power to the fold mirror **116** to compensate for the magnification difference (which may or may not be achromatic); (3) adding a refractive element (lens) between the fold mirror **116** and polarization switch **120**, or between the PBS **112** and fold mirror **116**; a singlet lens is unlikely to be achromatic, but a doublet solution can be achromatic; (4) addition of a telephoto lens as illustrated in FIGS. **3** and **4**; or (5) a combination of at least two of the above four techniques.

[0027] Although as described, p-polarized light is transmitted toward the polarization switch **120**, while s-polarized light is directed toward half-wave plate **114**, it should be apparent to a person of ordinary skill in the art that an alternative configuration may be employed in which s-polarized light is transmitted toward the polarization switch **120**, while p-polarized light is directed toward the half-wave plate **114**.

[0028] FIG. **3** is a schematic diagram showing another embodiment of a PCS for cinematic projection **200**. The elements of PCS **200** may be of similar type and function for those shown with respect to PCS **100** of FIG. **2**. For instance, elements **2xx** are similar to elements **1xx**, where **xx** are the last two digits of the respective elements. In this embodiment, ray bundles **A**, **B**, and **C** may be directed through an additional set of fold mirrors **232**, **234** operable to equalize the optical path lengths of bundles **A** and **A'**, **B** and **B'**, **C** and **C'** as shown in FIG. **3**. [Note: bundles **A'** and **C'** are present, but not illustrated. They follow a similar path to the **A'**, **B'**, **C'** bundles shown in FIG. **2**]. Note that although the PBS and fold mirrors are shown here to be orientated at 45 degrees to the optical axis, the PBS **212** and fold mirrors **216**, **232**, **236** may have other orientations in accordance with the present teachings. Additionally, glass may be inserted into the optical path of **A'**, **B'**, and **C'** (e.g., by replacing the fold mirror **216** with a right angle prism and/or using a glass cube PBS in place of a plate PBS) to reduce or eliminate the optical path difference between the **A**, **B**, **C** and **A'**, **B'**, **C'** bundles, respectively.

[0029] With reference to FIGS. **2** and **3**, the image from bundles **A'**, **B'**, and **C'** should substantially overlap the image from bundles **A**, **B**, and **C** for viewing comfort (although perfect overlap is not necessarily required). Some techniques of adjusting one image location relative to the other include (1) using thumb screws or a similar mechanical techniques to tilt the fold mirror, PBS plate, or PBS cube; (2) mechanically de-centering a lens or element with optical power (e.g. curved mirror); (3) utilizing a feedback system to automatically adjust image position via one of the aforementioned image adjustment techniques; or (4) a combination of at least two of the above three techniques.

[0030] Optical transmission and stray light control may be optimized on optically transmissive elements by providing an anti-reflection coat thereon for high transmission and low reflection. Reflections from transmissive elements can cause stray light in the system which degrades contrast and/or produces disturbing artifacts in the final image. In some embodiments, additional absorptive polarizers may be placed after the half-wave plate **114** in the **A'**, **B'**, **C'** path and/or after the PBS **112** in either path to control polarization leakage and improve the final image contrast.

[0031] FIG. **4** is a schematic diagram showing another embodiment of a PCS for cinematic projection **300**. The elements of PCS **300** may be of similar type and function for those shown with respect to PCS **100** of FIG. **2**. For instance, elements **3xx** are similar to elements **1xx**, where **xx** are the last two digits of the respective elements.

[0032] In this exemplary embodiment, a telephoto lens pair **340** may be implemented in the optical path where light transmits through the PBS **312**. Here, telephoto lens pair **340** is located along an optical path and with the field of view centered on the optical axis. Typically, telephoto lens **340** allows control of magnification, distortion, and imaging properties with two elements such that the two images overlay relatively close, i.e., within 1-4 pixels of each other, while maintaining spots sizes on the order of a fraction of a pixel and lateral color on the order of a pixel. Alternatively, a reverse telephoto lens (not shown) may be implemented in the optical path where light reflects from the PBS **312** (located between the polarization switch **320** and fold mirror **316**, or after the fold mirror **316**). If a telephoto or reverse telephoto lens is used for controlling magnification in one optical path, the radial distortion and keystone distortion of the final image can be tuned by laterally displacing the individual elements or pair of elements from the optical axis.

[0033] FIG. **5** is a schematic diagram showing another embodiment of a PCS for cinematic projection **400**. The elements of PCS **400** may be of similar type and function for those shown with respect to PCS **100** of FIG. **2**. For instance, elements **4xx** are similar to elements **1xx**, where **xx** are the last two digits of the respective elements. In this exemplary embodiment, a telephoto lens pair **440** may be implemented in the optical path where light transmits through the PBS **412**. Here, telephoto lens pair **440** is located along an optical path and with the field of view decentralized from the optical axis. Just as described above, the radial distortion and keystone distortion of the final image can be tuned by laterally displacing the individual elements or pair of elements **440** from the optical axis.

[0034] FIG. **6** is a schematic diagram of another embodiment of a PCS for cinematic projection **500** that provides a circularly polarized output. PCS **500** includes a telephoto lens pair **540** along an optical path, with field of view centered on an optical axis. In this case, each polarization switch **520** is a circular polarization switch (or Z-screen), e.g., as described in U.S. Pat. No. 4,792,850. The cleanup polarizers **542**, **544** in each path are optional, depending on the level of contrast desired from the system. For example, including one or both cleanup polarizers may enhance the system contrast.

[0035] FIG. **7** is a schematic diagram of another embodiment of a PCS for cinematic projection **600** that provides a linearly polarized output. Here, each polarization switch **620** is an achromatic linear polarization switch, as described in U.S. patent application Ser. No. 11/424,087 entitled "Achromatic Polarization Switches", filed Jun. 14, 2006; also manufactured by ColorLink, Inc., of Boulder, Colo. Similar to the example in FIG. **6**, cleanup polarizers **642**, **644** in each path are optional, depending on the level of contrast desired from the system. For example, including one or both cleanup polarizers may enhance the system contrast. Additionally, the achromatic rotator **648** is optional, depending on the achromatic properties of the polarization switch **620**.

[0036] FIG. **8** is a schematic diagram of another embodiment of a PCS for cinematic projection **700**, showing an alternative configuration in which the polarizers **746**, achro-

matic rotator **714**, and polarization switches **720** are located after other optical components. The elements of PCS **700** may be of similar type and function for those shown with respect to PCS **100** of FIG. 2. For instance, elements 7_{xx} are similar to elements 1_{xx} , where xx are the last two digits of the respective elements.

[0037] In operation, light exits projection lens **722** toward PBS **712**. P-polarized light passes through PBS **712** toward telephoto lens pair **740**, then toward polarization switch **720**. An optional cleanup polarizer **746** may be located between telephoto lens pair **740** and polarization switch **720** to further enhance contrast. The s-polarized light reflected by PBS **712** is directed toward fold mirror **716**, where it reflects toward an achromatic rotator **714** that transforms the s-polarized light into p-polarized light, then it passes through an optional cleanup polarizer **746**. Next, the p-polarized light from achromatic rotator **714** passes through polarization switch **720**. In this configuration, the s-polarized light reflected by the PBS **716** is efficiently reflected, with polarization maintained by the fold mirror **716**. This relaxes any want for polarization preservation from the fold path and maximizes brightness. An achromatic 90° rotator **714** (probably retarder stack based) can be used to convert light from the fold mirror to the orthogonal state. In order to eliminate P-reflection from the PBS **712**, a clean up polarizer **746** is likely desirable. This preferably follows the achromatic rotator **714**, thereby reducing polarization conversion efficiency as a factor in system level contrast.

[0038] PCS **700** provides a high contrast image on the screen. In this exemplary embodiment, the final screen image has a center located on the optical axis of the projection lens. In some other embodiments, the final screen image may be located off-center from the optical axis—for example, a half screen height below the optical axis of the projection lens. In such embodiments, the polarizing beamsplitter **712** may be relocated to intercept the full illumination from the projection lens **722**, and the fold mirror **716** may be tilted to properly overlay the two images on the screen. The polarization switch **720** in this embodiment has been split into two elements (one for each path) to increase fabrication yield; although, as previously discussed, it could alternatively be a single unit.

[0039] As used herein, the term “cinematic projection” refers to the projection of images using front and/or rear projection techniques, and includes, but is not limited to, applications for cinema, home theatre, simulators, instrumentation, head-up displays, and other projection environments where stereoscopic images are displayed.

[0040] While several embodiments and variations of polarization conversion systems for stereoscopic projection have been described above, it should be understood that they have been presented by way of example only, and not limitation. Thus, the breadth and scope of the invention(s) should not be limited by any of the above-described exemplary embodiments, but should be defined only in accordance with any claims and their equivalents issuing from this disclosure. Furthermore, the above advantages and features are provided in described embodiments, but shall not limit the application of such issued claims to processes and structures accomplishing any or all of the above advantages.

[0041] Additionally, the section headings herein are provided for consistency with the suggestions under 37 CFR 1.77 or otherwise to provide organizational cues. These headings shall not limit or characterize the invention(s) set out in any claims that may issue from this disclosure. Specifically and

by way of example, although the headings refer to a “Technical Field,” such claims should not be limited by the language chosen under this heading to describe the so-called technical field. Further, a description of a technology in the “Background” is not to be construed as an admission that technology is prior art to any invention(s) in this disclosure. Neither is the “Brief Summary” to be considered as a characterization of the invention(s) set forth in issued claims. Furthermore, any reference in this disclosure to “invention” in the singular should not be used to argue that there is only a single point of novelty in this disclosure. Multiple inventions may be set forth according to the limitations of the multiple claims issuing from this disclosure, and such claims accordingly define the invention(s), and their equivalents, that are protected thereby. In all instances, the scope of such claims shall be considered on their own merits in light of this disclosure, but should not be constrained by the headings set forth herein.

What is claimed is:

1. A polarization conversion system comprising:
 - a polarization beam splitter (PBS) operable to receive randomly-polarized light bundles from a projector lens, and direct first light bundles having a first state of polarization (SOP) along a first light path, and direct second light bundles having a second SOP along a second light path;
 - a polarization rotator located on the second light path, the polarization rotator being operable to translate the second SOP to the first SOP; and
 - a polarization switch operable to receive first and second light bundles from the first and second light paths respectively, and to selectively translate the polarization states of the first and second light bundles to one of a first output SOP and a second output SOP.
2. The polarization conversion system of claim 1, further comprising a reflector located on the second light path, operable to direct second light bundles to substantially similar locations on a projection screen as the first light bundles.
3. The polarization conversion system of claim 1, wherein the polarization switch comprises a single panel that receives light from the first light path and the second light path.
4. The polarization conversion system of claim 1, wherein the polarization switch comprises first and second polarization switch panels, the first polarization switch panel receiving light from the first light path, and the second polarization switch panel receiving light from the second light path.
5. The polarization conversion system of claim 4, further comprising a telephoto lens pair located on the first light path, after the first polarization switch.
6. The polarization conversion system of claim 1, wherein the first output SOP is orthogonal to the second output SOP.
7. The polarization conversion system of claim 1, further comprising a pair of mirrors located on the first light path after the polarization switch, the pair of mirrors being operable to substantially equalize the optical path length between the first light path and the second light path.
8. The polarization conversion system of claim 1, wherein the polarization switch selects between the first and the second output SOP in synchronization with transmission of an image frame by a projector.
9. The polarization conversion system of claim 1, wherein the polarization rotator comprises a retarder stack.
10. A polarization conversion system, comprising:
 - a polarization beam splitter operable to direct light on first and second light paths;

a polarization rotation element located on the second light path;
 a reflector element located on the second light path; and
 a polarization switch located on the first light path and on the second light path after the reflector element, wherein the reflector element is operable to direct the second light path toward substantially similar locations on a projection screen as the first light path.

11. The polarization conversion system of claim **10**, wherein the polarization switch comprises a single panel that receives light from the first light path and the second light path.

12. The polarization conversion system of claim **10**, wherein the polarization switch comprises first and second polarization switch panels, the first polarization switch panel receiving light from the first light path, and the second polarization switch panel receiving light from the second light path.

13. The polarization conversion system of claim **12**, further comprising a telephoto lens pair located on the first light path, after the first polarization switch.

14. The polarization conversion system of claim **10**, wherein the polarization switch selects between a first and a second output state of polarization in synchronization with transmission of an image frame by a projector.

15. A projection system utilizing polarized light for encoding stereoscopic images, comprising:

a projector comprising a projection lens operable to output randomly-polarized light;
 a polarization conversion system optically coupled to the projection lens, comprising:

a polarization beam splitter operable to direct light on first and second light paths;
 a polarization rotation element located on the second light path;
 a reflector element located on the second light path; and
 a polarization switch located on the first light path and on the second light path, wherein the first light path forms an image on a projection screen, and wherein the reflector element directs light on the second light path toward the projection screen.

16. The projection system of claim **15**, wherein the polarization switch is located after the reflecting element on the second light path.

17. The projection system of claim **15**, wherein the polarization switch is located before the reflecting element on the second light path.

18. A method for stereoscopic image projection, comprising:

receiving randomly-polarized light from a projector;
 directing first state of polarization (SOP) light on a first light path;
 directing second SOP light on a second light path;
 transforming the second SOP light on the second light path to first SOP light;
 selectively translating the first SOP light on both light paths to one of a first output SOP and a second output SOP.

19. The method for stereoscopic image projection of claim **12**, further comprising the step of directing the first and second light paths toward a projection screen.

20. The method for stereoscopic image projection of claim **12**, further comprising synchronizing the first output SOP and second output SOP with transmission of an image frame from the projector.

* * * * *