

(19)
(12)

(KR)
(Y1)

(51) 。 Int. Cl.7
F28D 9/00

(45)
(11)
(24)

2003 09 02
20-0324980
2003 08 19

(21) 20-2003-0018788
(22) 2003 06 16

(73) 가
681-15

(72) 1037 102 1904

(74)

:

가 :

(54)

가 , (10) 가 (50) (10) (6)

0)(70) (11~14) (10) (10) (60)(70)

가 (W) (11~14) 가

3

1

2 1

3

4 2 - ,

5 2 - ,

6 7 2

* *

10.. 11~14..

20.. 30..

40.. 50..

60(600) 1 70(700).. 2

가 가

가 가

가

가

()가

가

가 ,

가 1 (4) 가 (1) (4) (3) (2a)(2b) (1) (3) (1) (2c)(2d)가 (2) (3) ()

(1) (4) (3) (5)가 (1) (4) (1a) 2 (1b) (1) (1c) 4 (1d) (4) 1 (1) (3) (2a) , 2 (1b) (2b) (2c) , 4 (1d) (2d) (1c) (2a) (2c) , 4 (1d) (2b) (2d) (1a ~ 1d) 가 (BRAZING) (1) (1e)가 1 4 (3) 가 (2c) 4 (1d) , 3 (1c) (2d) () ()가 (2a) , 1 (1a) (4) (2b) ()

).

, 2 (1b) (2) (4) (2b) (1) , 1 (1a) 3 (1c)
 (3) (4) 1 , 90
 가 , 1 4 (1a ~ 1d) , 1 4 (1) (1a ~ 1d)
 (1e)가 ,
 가 .
 , 1 4 (1a ~ 1d) , 90 (가
 ;1e) 가 , 가 1 4 (1a ~ 1d) (가
 가 (混流) 가 .

가 ;

;

가

가 (50)가 , .
 , 1 , 2 , 3 , 4
 ,

1 4 가 ,

.(1

, 2 . 가 가
 .)

1 , 2 3 ,
 (10) , (10) , (23)(24)가
 (20) , (21)(22) , (23)(24) (20)

0) "V" (10) (30) (40) 가 가 (5)
 , (10) (50) (30) (40)가 가 (10) .

(40) 3 5 , (10) (20) (21)
(40) 2 (11) (12) (20) (22) (10) (20) (23)
(30) (30) 3 (13) (20) (24)
(14)

(40) (10) (10) 3 (13) 4 (14) 1
(60)가 (10) 가 (40) (10) 1
(11) 2 (12) 2 (70)가 (10) 가 (30)

1 (60) 2 (70) (10)
1 4 (11~14) (30) (40)가

1 (60) 2 (70) (10) 가
1, (60) 2 (70) (50)
(10)

(10) 1 (60) 2 (70)

(10)

10) 3 (W)가 1 (60) 1 4 (11~14) (()
() (過水壓) (10) (70)

4 5

() 가 가 () (23)
4 (30) 3 4 (13) (30)
() (14) (24)

3 (13) (30) 90 3
(13) 4 (10) 가 (50)
(14) 가

(10) 3 (13) 4 (14) 1 (60) (10)
(3 W)

()가 (21) 5 1
(11) 2 (40) (40) () ()
(12) (22)

1 (11) 가 (40) 90 1
(11) 가 가 (50) () 2 (12)

1 (11) 2 (12) 2 (70) (W)

(10) (W)

가¹

6 7 2

(100) (230)(240)가 (200) (210)(220) (210)(220)

(230)(240) () ()

(100) 1 (110) 2

(120) 3 (130) 4 (140) 1 (110) (210)

2 (120) (220) 3 (130)

(230) 4 (140) (240)

1, 2 (110)(120) 3,4 (130)(140) (100) 1, 2

(100) 가 (100)

(600)(700)가 가 (100)

1, 2 (600)(700) (100)

(100) 1, 2 (600)(700)

(500) 1 4 (110~140)

(100) 1 4 (110~140)

가

가

가

(57)

1.

(21)(22) (50)가 (30) (40) 가 (10)

(10) (10) (23)(24)가 (10) (20) (20) 1 (21)

(10) 2 (22) (40) (11) (40)

(10) (12) (20) 3 (23) (10) (24)

(30) (30) (13) (20) 4 (14)

(10) 1 4 (11~14) (10)

(50) (60)(70)가 (10)

(60)(70) (10)

1

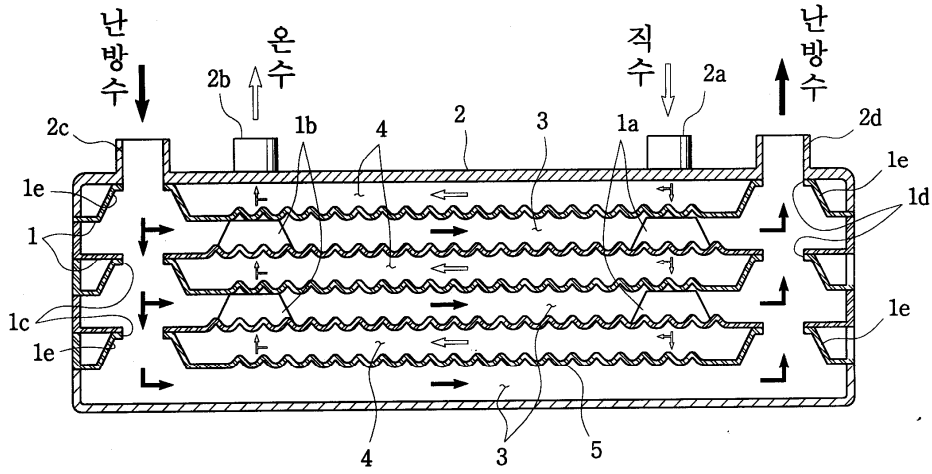

2

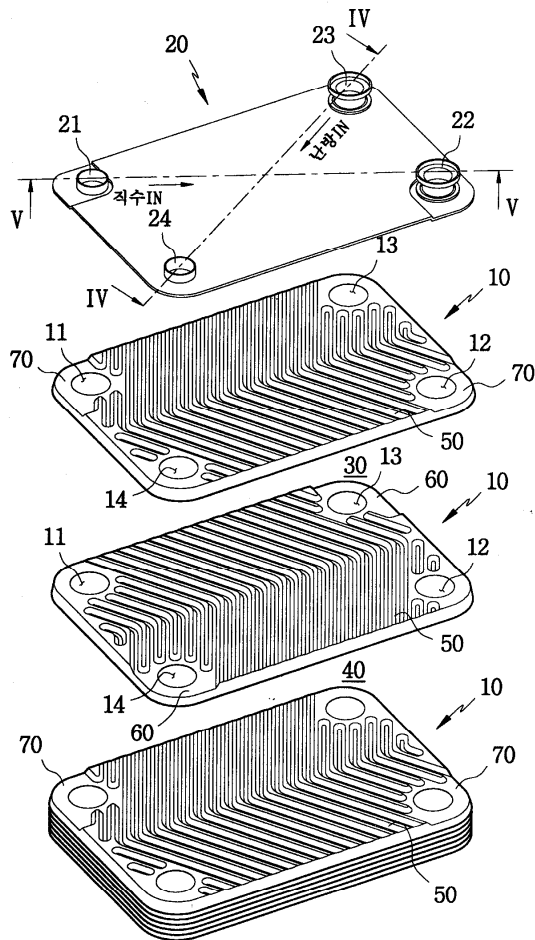

3

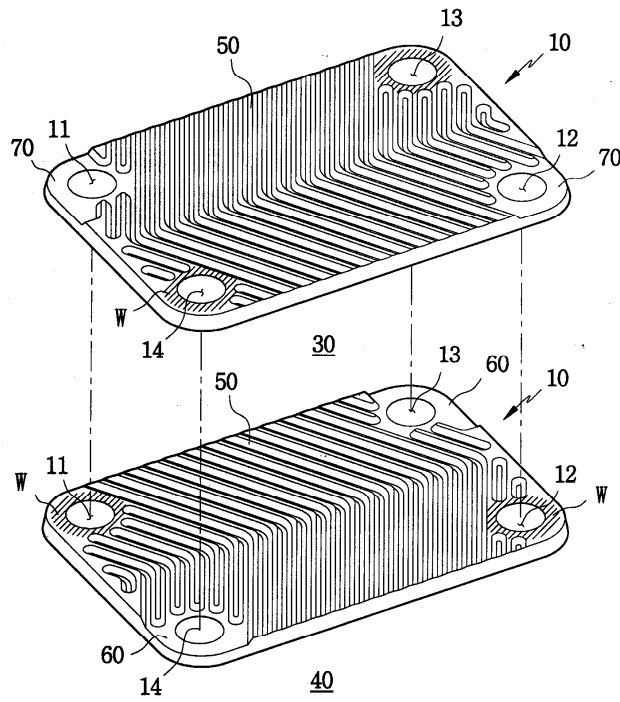

4

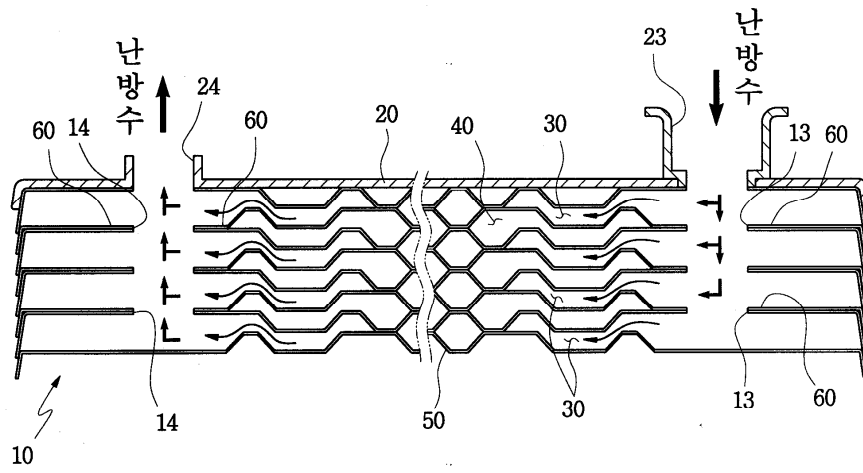

5

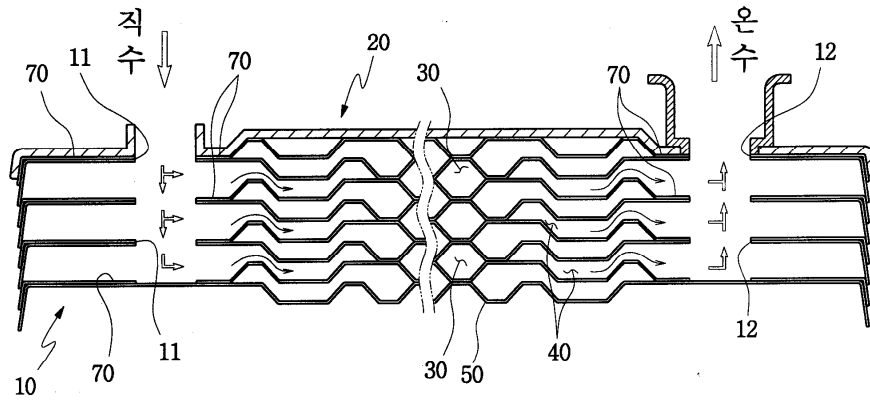

6

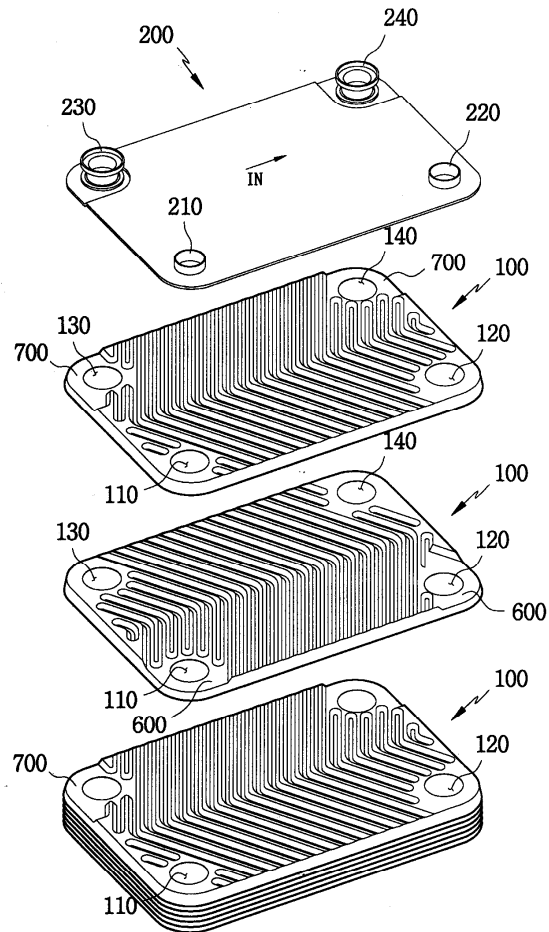

7

