

(19)
(12)

(KR)
(B1)

(51) 。 Int. Cl.⁷
B62D 1/04

(45)
(11)
(24)

2003 12 06
10-0408551
2003 11 25

(21) 10-2002-0018010
(22) 2002 04 02

(65) 2003-0079167
(43) 2003 10 10

(73) 1070-7

(72) 1344 503 501

(74)

:

(54)

가 가 가

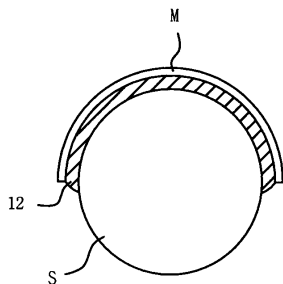

1
 2
 3a 3b
 4a 4b 1
 5a 5b 1
 6a 6b
 7
 8a 8b 2
 9a 9b 2
 ()
 1 : 2 :
 3 : 가 4 :
 5 : 6 :
 7 : 8 :
 9 : 10 :
 11 : 12 : 1
 13 : 2
 A : S :
 F : W :
 P : D :
 K : M :

1

2

가

가

(Hair line)

(Wood), (Metal), (Carbon), (Marble)

10-2000-19074

가

2

2

()

2

가

가 2

2

10-2000-19075

가

가

가

가

1 (S) 가 , 2

2 (W) (5) (2) (6) (11), (8) (F) 가 가 (F) (K) (8) (9) (10) (11) (8) (7) (F) 가 가

(2) (4) (2) 가 (F) (2) (W) (3) (3) 2 가 (3) (F) (1) (W) (S) 가 가 (F) (1) (S) (S)

3a (S) 3b 가 (S) PVA() (S) 가 (1) (12) (4a 4b), (12) 가 가 (12) (M)가 (5a 5b). (12) 가 (S) 6a 6b (2 1) 가 (2) 7 (8a 8b). (13) , 1 (12) 2 (13) 가 9a 9b

가 가

가

(57)

1.

가

2.

1

3.

1

4.

1

5.

1

6.

5

7.

1

6

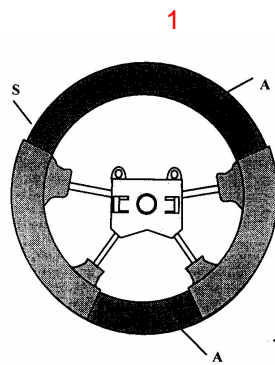

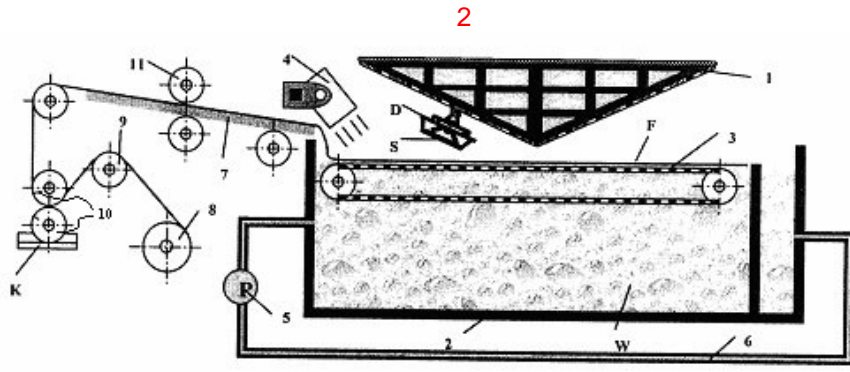

3a

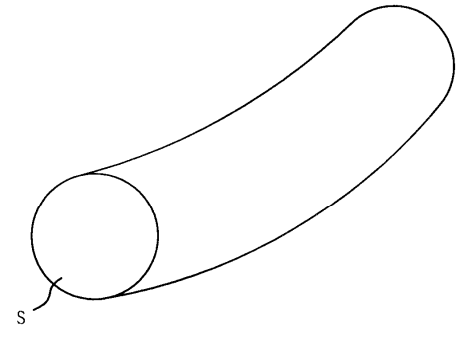

3b

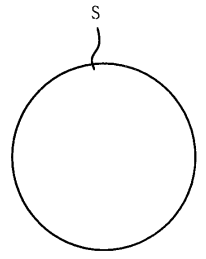

4a

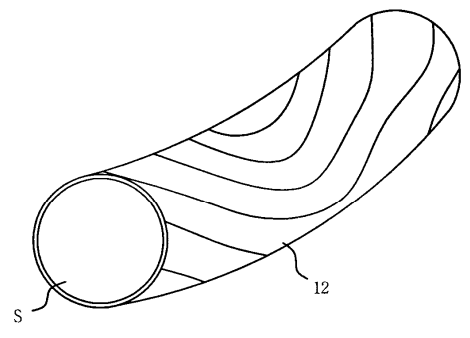

4b

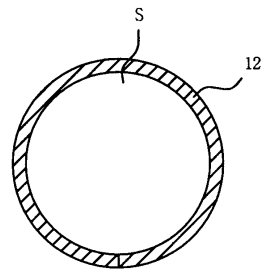

5a

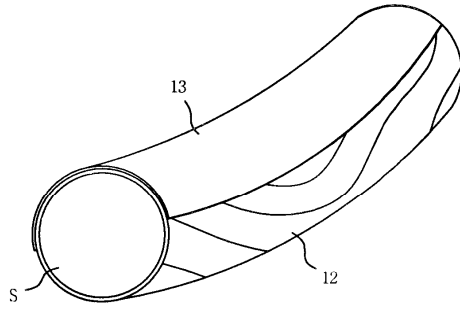

5b

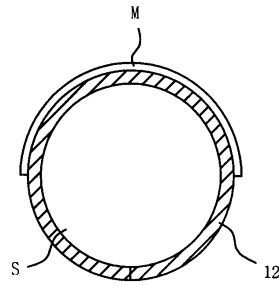

6a

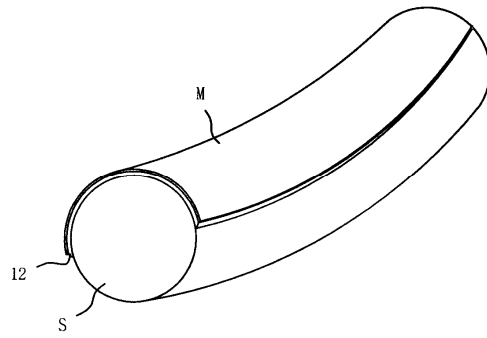

6b

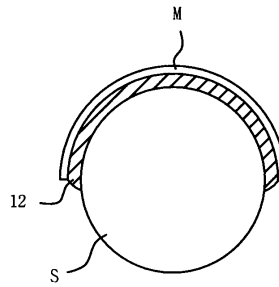

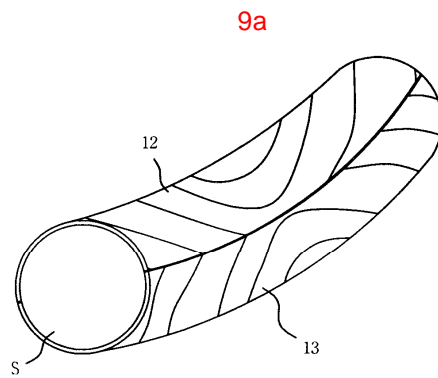
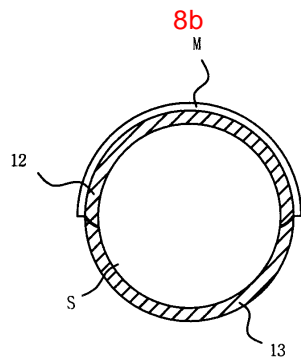
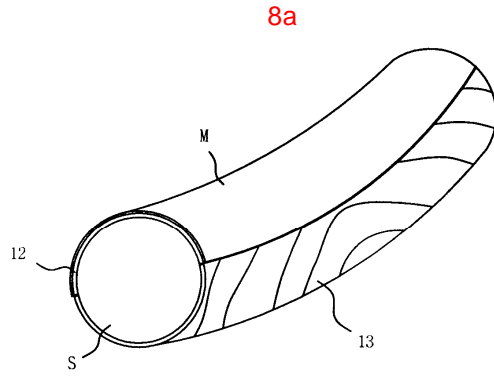
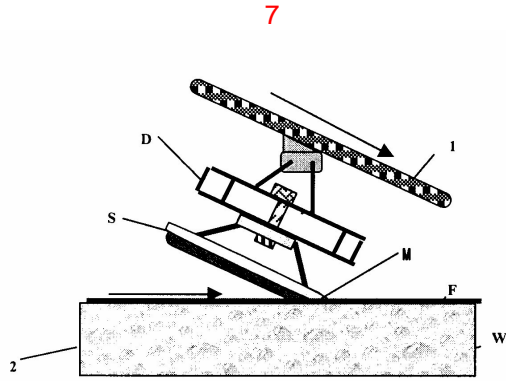

9b

