



US 20130199037A1

(19) **United States**

(12) **Patent Application Publication**
Okumura

(10) **Pub. No.: US 2013/0199037 A1**

(43) **Pub. Date: Aug. 8, 2013**

(54) **METHOD FOR PRODUCING GLOW PLUG TERMINALS, AND METHOD FOR PRODUCING GLOW PLUGS**

Publication Classification

(75) Inventor: **Yuki Okumura**, Nagoya-shi (JP)

(51) **Int. Cl.**
H01R 43/00 (2006.01)

(73) Assignee: **NGK SPARK PLUG CO., LTD.**,
Nagoya, Aichi (JP)

(52) **U.S. Cl.**
CPC **H01R 43/00** (2013.01)
USPC **29/874**

(21) Appl. No.: **13/876,191**

(22) PCT Filed: **Aug. 17, 2011**

(57) **ABSTRACT**

(86) PCT No.: **PCT/JP2011/068628**

§ 371 (c)(1),
(2), (4) Date: **Mar. 27, 2013**

A method of producing a glow plug, wherein a pin terminal is produced by applying a plastic working to a workpiece made of a conductive metal. The production method has: a first step of obtaining a first workpiece; a second step of setting the first workpiece to a second workpiece; a third step of setting the second workpiece to a third workpiece; and a fourth step of setting the third workpiece to a fourth workpiece.

(30) **Foreign Application Priority Data**

Oct. 5, 2010 (JP) 2010-225595
Oct. 5, 2010 (JP) 2010-225599

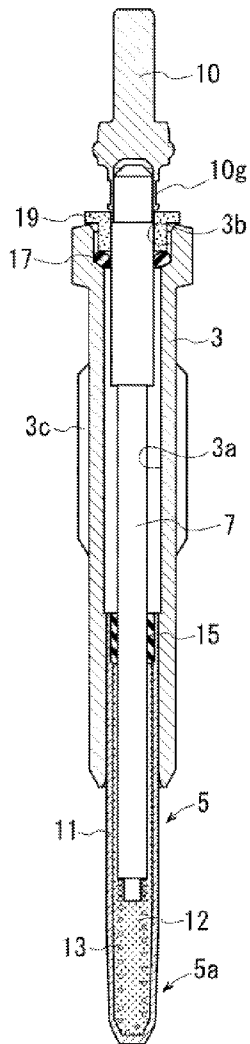
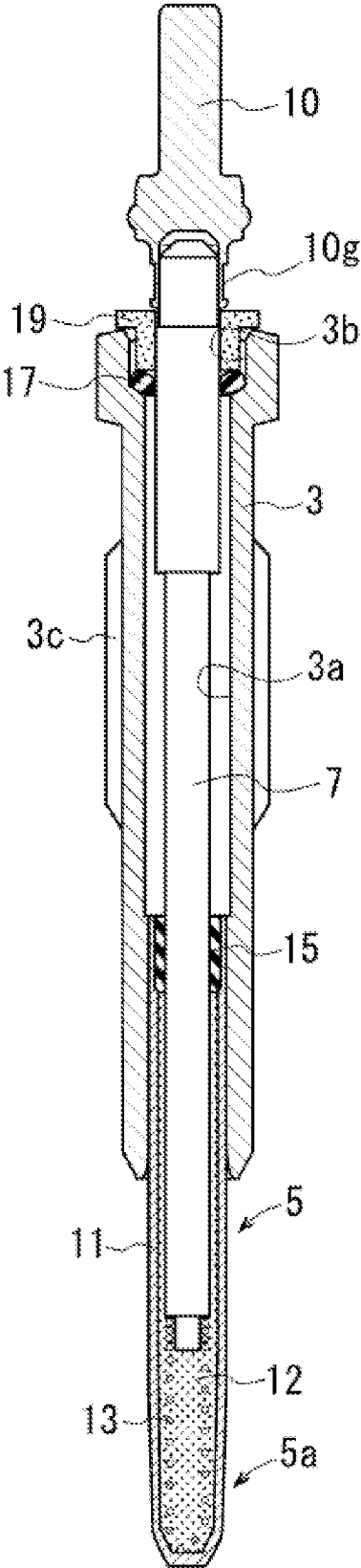
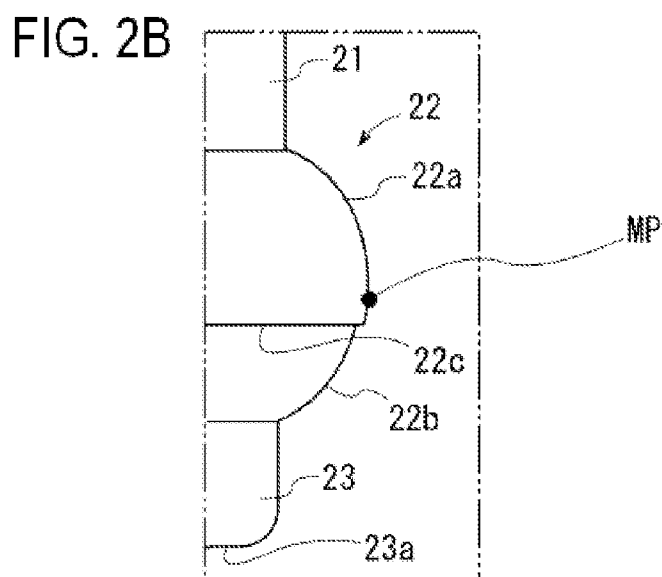
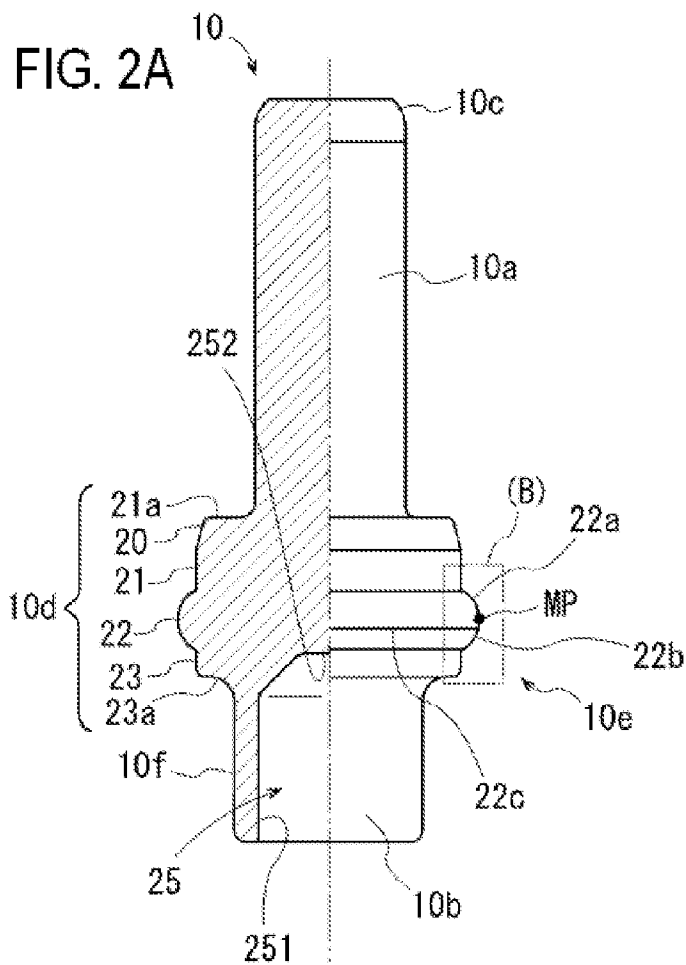

FIG. 1





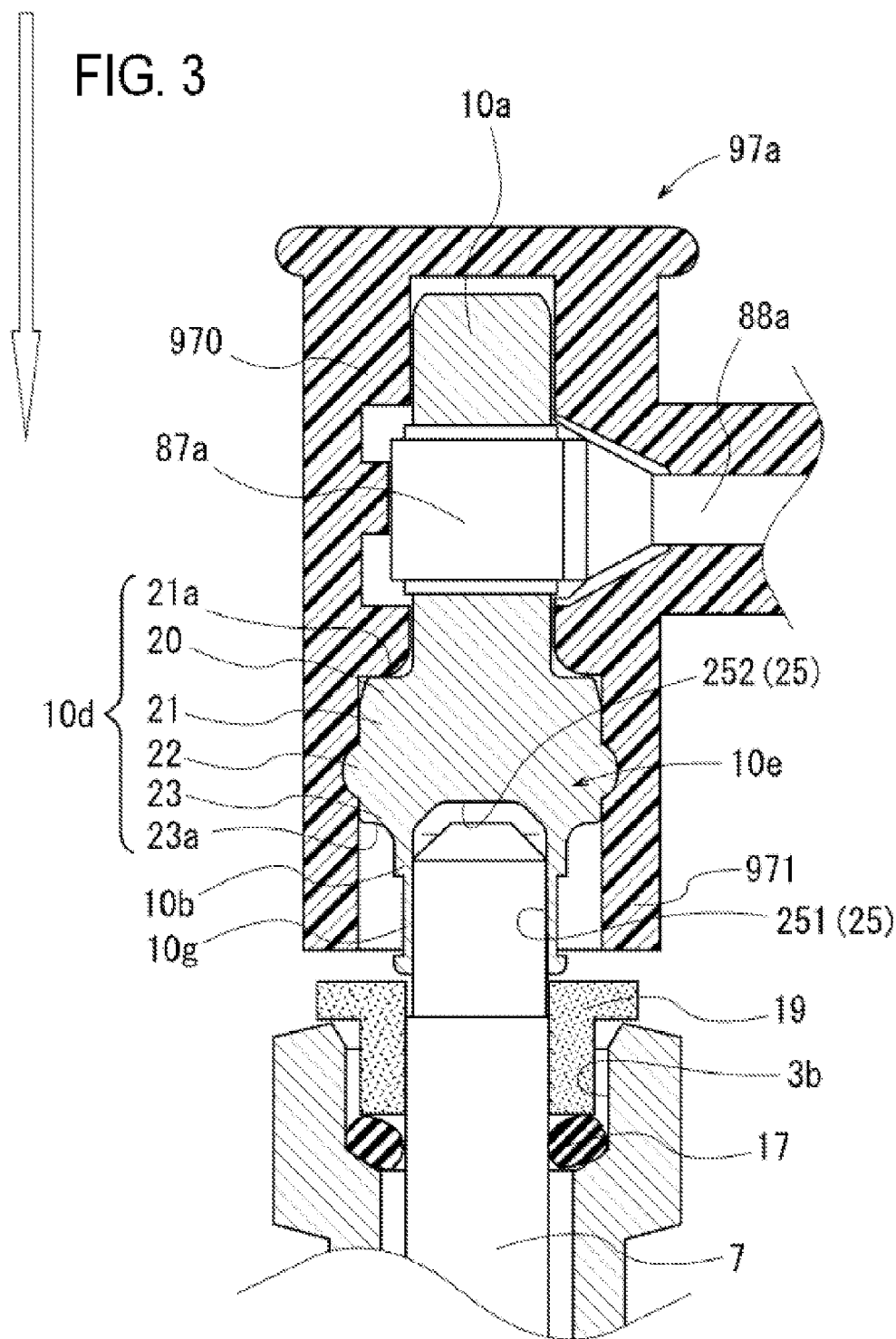

FIG. 4A

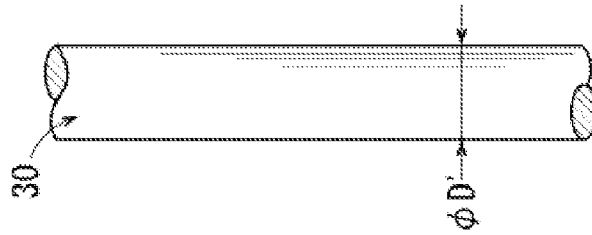

FIG. 4B

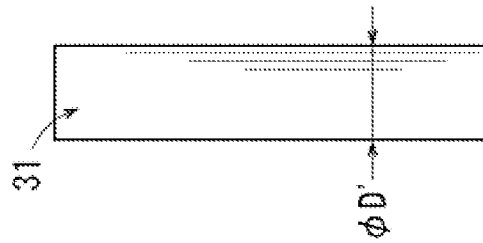

FIG. 4C

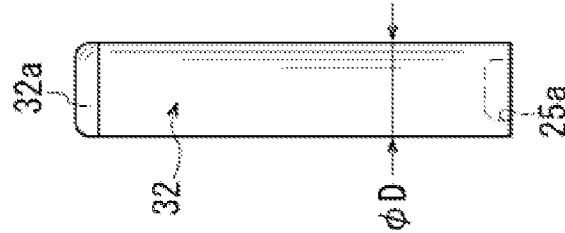

FIG. 4D

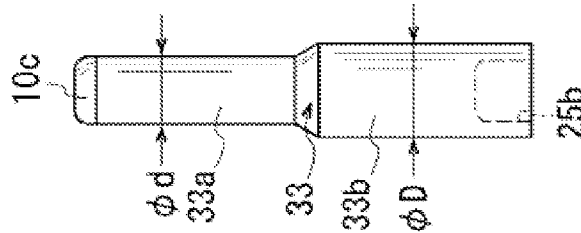

FIG. 4E

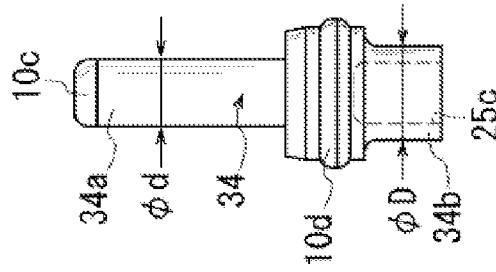

FIG. 5

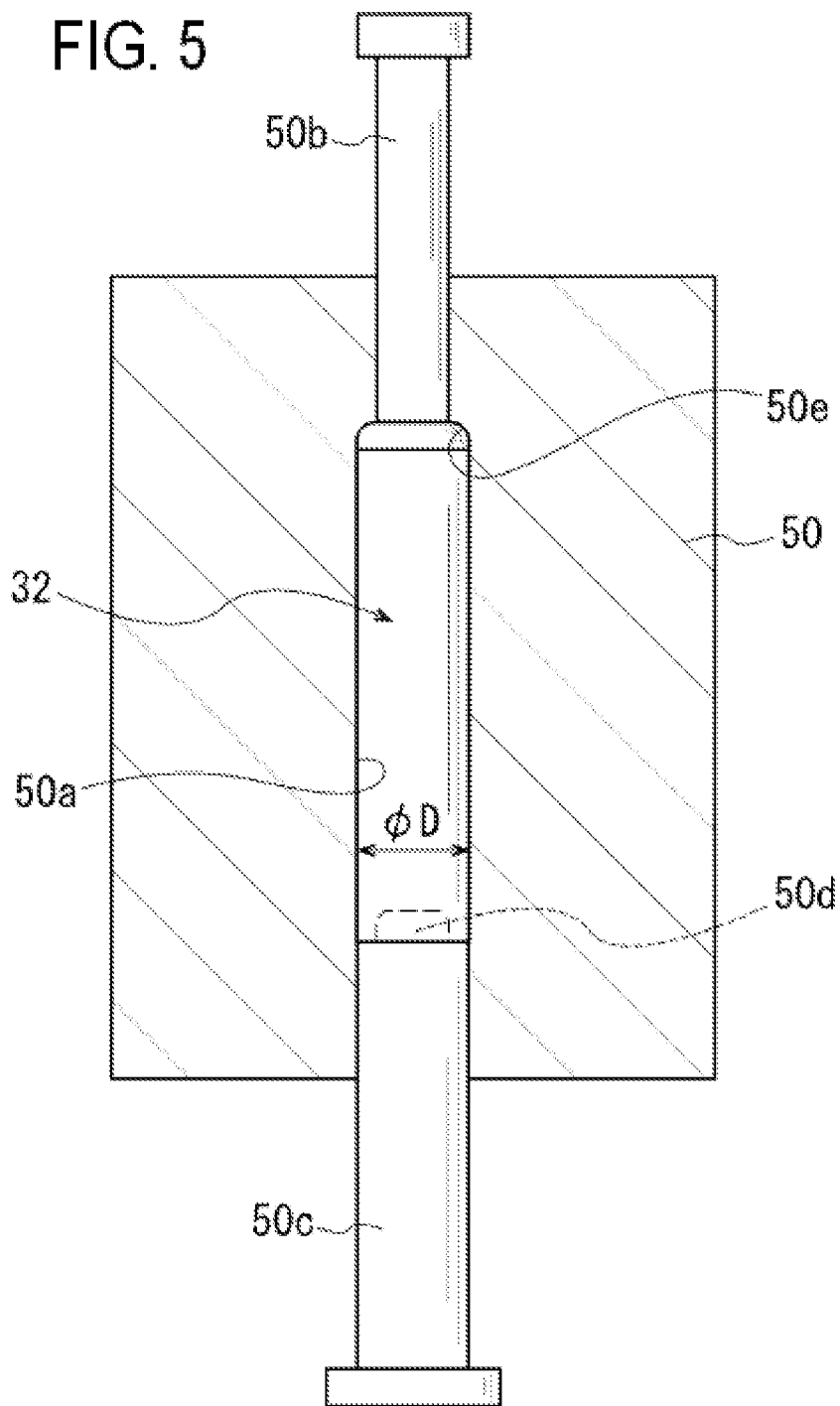
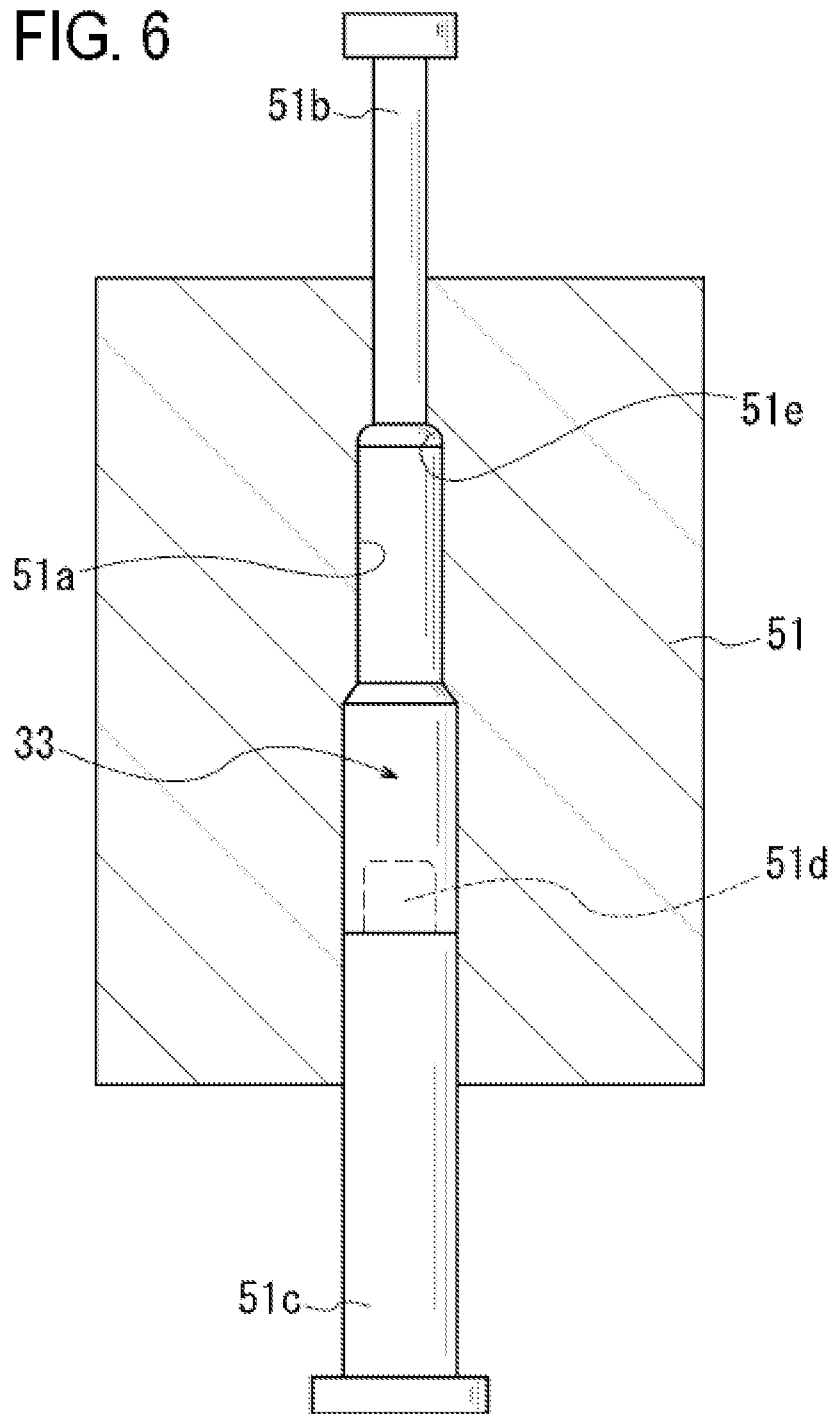

FIG. 6



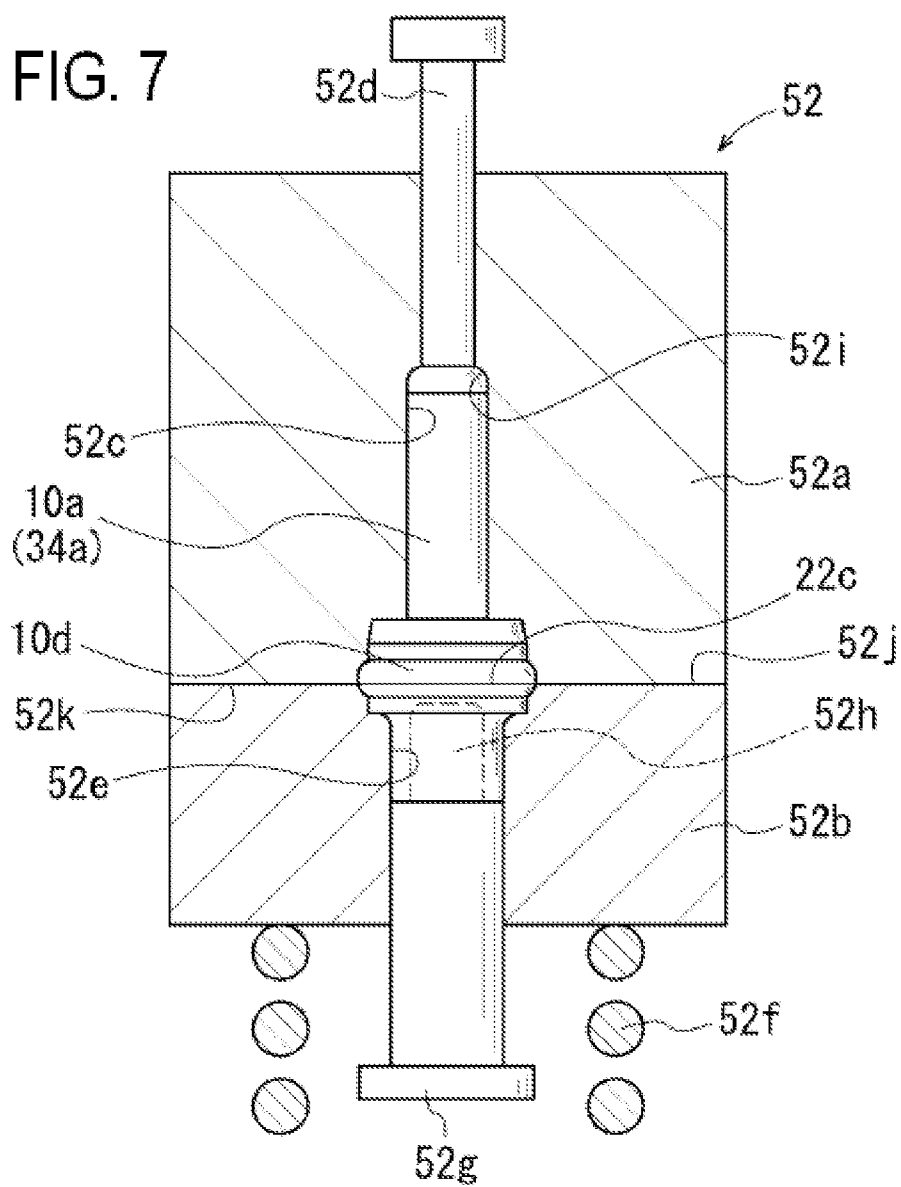

FIG. 8

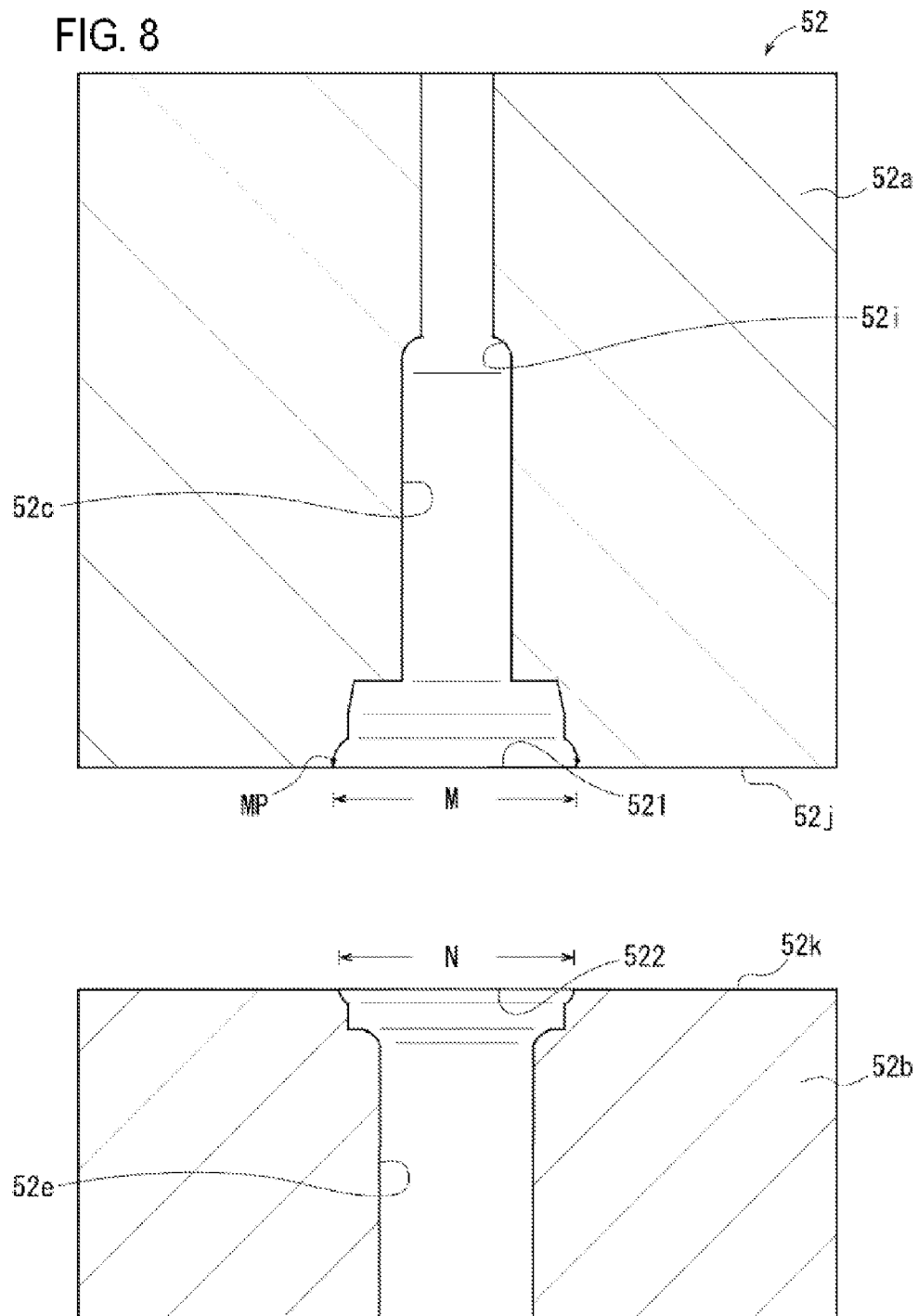
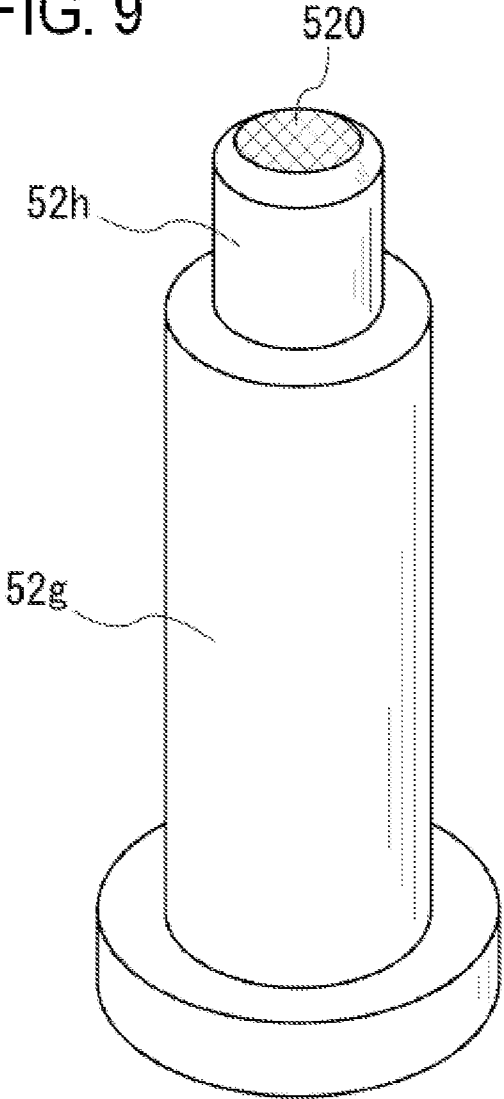

FIG. 9



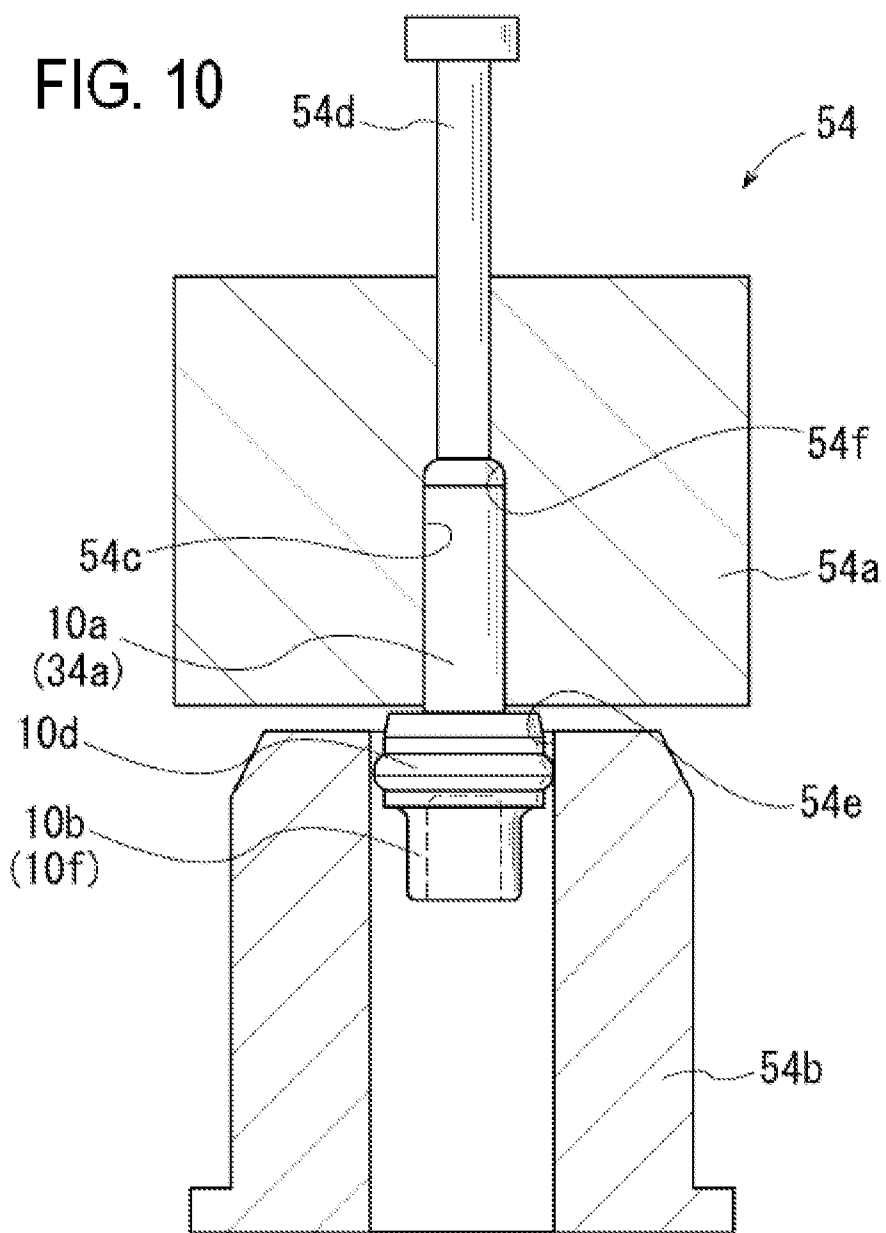
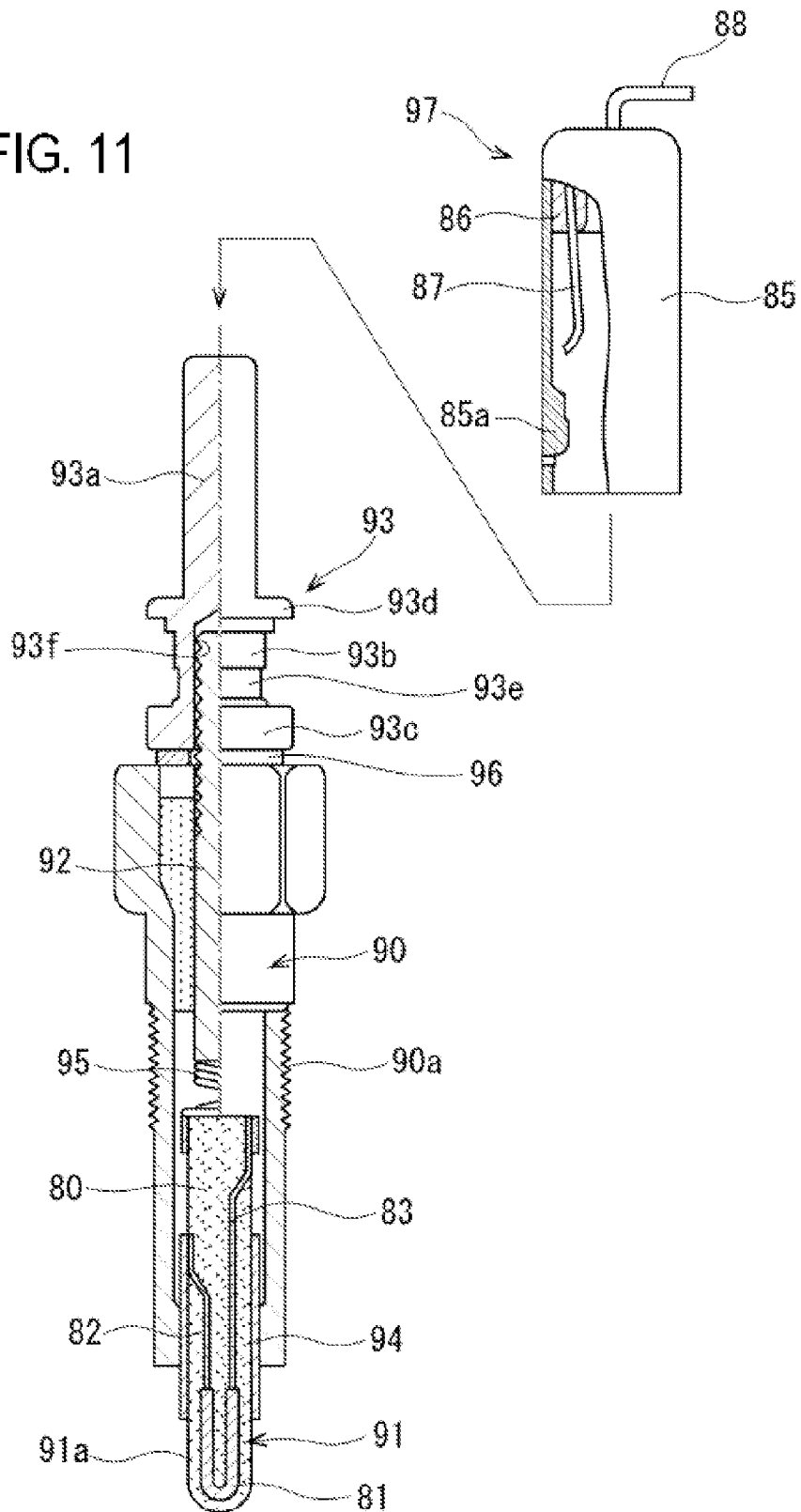

FIG. 11



**METHOD FOR PRODUCING GLOW PLUG
TERMINALS, AND METHOD FOR
PRODUCING GLOW PLUGS**

FIELD OF THE INVENTION

[0001] The present invention relates to a method of producing a pin terminal for a glow plug, and a method of producing a glow plug.

BACKGROUND OF THE INVENTION

[0002] JP-A-2002-260827 discloses a conventionally known glow plug. As shown in FIG. 11 of the aforementioned Japanese Patent document, the glow plug includes: a cylindrical housing 90; a heater 91 which is fixed into the housing 90, and which has a heating portion 91a projecting from the tip end of the housing 90; a rod-like inner shaft 92 which is placed in the housing 90, and in which a rear end portion projects from the rear end of the housing 90; and a pin terminal 93 which is fitted to the rear end portion of the inner shaft 92, and which is used for supplying electricity from the outside to the heating portion 91a through the inner shaft 92.

[0003] The heater 91 is a ceramic heater which is fitted into an outer sleeve 94 that is fitted to the tip end side of the housing 90, and that is made of a conductive metal, and which allows the heating portion 91a to project from the tip ends of the housing 90 and the outer sleeve 94.

[0004] The ceramic heater 91 is configured by a rod-like insulating member 80 containing Si_3N_4 as a major component. A U-shaped heating member 81 is embedded in the tip end side of the insulating member 80, and contains WC as a major component. A first lead wire 82 has one end connected to one end of the heating member 81, and the other end exposed from a part of the outer circumferential surface of the insulating member 80. A second lead wire 83 has one end connected to the other end of the heating member 81, and the other end exposed from another part of the outer circumferential surface of the insulating member 80. The other end of the first lead wire 82 is connected to the outer sleeve 94, that the other end of the second lead wire 83 is connected to an electric coil 95, and the electric coil 95 is connected to the inner shaft 92. The tip end side of the insulating member 80, in which the heating member 81 is embedded, functions as a heating portion 91a of the ceramic heater 91.

[0005] The pin terminal 93 has a small-diameter portion 93a in the rear end side, and a large-diameter portion 93b in the tip end side. The end surface on the rear end side of the small-diameter portion 93a has a curved surface shape. A first flange 93c, which abuts against an insulator 96 that is disposed on the rear end side of the housing 90 and that is made of an insulating material, is formed on the tip end side of the large-diameter portion 93b. A second flange 93d is formed on the rear end side of the large-diameter portion 93b. An engagement portion 93e, that engages an engagement convex portion 85a of a cap 97 to which electricity is supplied from the outside, is formed between the first flange 93c and the second flange 93d.

[0006] In the glow plug, the heating portion 91a of the ceramic heater 91 is located in a combustion chamber of a diesel engine by screwing a male thread 90a of the housing 90 to a cylinder head of the diesel engine. Then, the housing 90 is grounded to the cylinder head, and the cap 97 which leads to a battery, is fitted to the pin terminal 93. The cap 97 is configured by a cup-shaped cap body 85, and an electric

conductive member 87 which is fixed, for example, in a state where the electric conductive member extends from the inner side toward the opening side, by a fixing member 86 that is disposed in the inner side of the cap body 85. An engagement convex portion 85a which inwardly projects is formed in the opening side of the cap body 85. The electric conductive member 87 is connected to a lead wire 88 which leads to the battery.

[0007] When the cap 97 is fitted to the pin terminal 93, the engagement convex portion 85a of the cap body 85 overrides the second flange 93d to be engaged with the engagement portion 93e. In the state, the electric conductive member 87 abuts against the surface of the small-diameter portion 93a.

[0008] In the ceramic heater 91, therefore, a voltage is applied between: the housing 90, the outer sleeve 94, and the first lead wire 82; and the pin terminal 93, the inner shaft 92, the electric coil 95, and the second lead wire 83, and heating portion 91a generates heat by means of the heating member 81. Therefore, starting of the diesel engine is initiated.

[0009] According to the publication, a glow plug of this kind is produced in the following manner. Namely, the housing 90, the ceramic heater 91, the inner shaft 92, and the like are first produced. Furthermore, the pin terminal 93 is produced by applying a cutting process to a workpiece made of steel. While required places of these components are electrically connected to one another, then, these components are assembled together, and a glow plug is completed.

[0010] In the method of producing a glow plug, however, the pin terminal is produced only by the cutting process performed on the workpiece. Therefore, swarf is excessively wasted, the time period required for production is long, and mass production is difficult. In the conventional production method, therefore, reduction of the production cost of a pin terminal is difficult. Accordingly, also reduction of the production cost of a glow plug is difficult.

[0011] The applicant of the present application has filed a patent application related to a method of producing a pin terminal for a glow plug, and method of producing a glow plug which can solve the problems, and obtained a patent on the production methods (Japanese Patent No. 4,241,489). In the production methods, small- and large-diameter portions, first and second flanges, and engagement portion of a pin terminal are formed by a plastic working on a workpiece.

[0012] According to the production methods, as compared with the case where a pin terminal is produced only by applying a cutting process to a workpiece, swarf is reduced, and the time period required for production can be shortened. Therefore, mass production is facilitated. According to the production methods, therefore, reduction of the production cost of a pin terminal is realized, and consequently reduction of the production cost of a glow plug is realized.

[0013] Also in the production methods, however, the first flange is formed in the tip end of the large-diameter portion, and the second flange is formed in the rear end side of the large-diameter portion in a similar manner as the pin terminal 93 of FIG. 11. In the pin terminal, therefore, a to-be-crimped portion which is formed to have the even outer diameter, and which is capable of being crimped is limited between the first flange and the second flange, and becomes short. In the short to-be-crimped portion, therefore, the inner shaft and the pin terminal are unlikely to be firmly coupled together. Therefore, the coupling strength between them must be ensured by employing a longish inner shaft. In the pin terminal, therefore, reduction of the material has not been sufficient, and also

reduction of the weight has not been sufficient. Also in a glow plug, since such a pin terminal is employed, and a longish inner shaft is employed, reduction of the material has not been sufficient, and also reduction of the weight has not been sufficient.

[0014] The invention has been conducted in view of the above-discussed circumstances. It is a problem to be solved to enable a high-quality and light-weight pin terminal for a glow plug, and consequently a high-quality and light-weight glow plug to be economically produced.

[0015] In accordance with the present invention, there is provided a method of producing a pin terminal for a glow plug, the method comprising:

[0016] obtaining a first workpiece which has a rod-like shape, and which is made of the conductive metal;

[0017] plastically deforming an end surface of a rear end side of the first workpiece into a curved surface shape to obtain a second workpiece;

[0018] plastically deforming a rear end side of the second workpiece into a small-diameter portion which is configured to be fitted to a cap for supplying electricity from an outside, and plastically deforming a tip end side of the second workpiece into a large-diameter portion which is larger in diameter than the small-diameter portion to obtain a third workpiece; and

[0019] plastically deforming a flange between the small-diameter portion and the large-diameter portion, the flange being larger in outer diameter than the large-diameter portion, and an engagement portion formed between a position where a diameter of the flange is maximum and the large-diameter portion, an outer diameter of the engagement portion being gradually reduced toward the large-diameter portion, and the engagement portion being configured to be engaged with the cap to obtain a fourth workpiece.

[0020] Also in the production method of the invention, the small-diameter portion, large-diameter portion, flange, and engagement portion of the pin terminal are formed by applying a plastic working to a workpiece in a similar manner as the above-described production method of Japanese Patent No. 4,241,489 issued to the applicant.

[0021] In the production method, moreover, the fourth workpiece which has the flange between the small-diameter portion and the large-diameter portion, and which does not have a flange in the tip end of the large-diameter portion is produced. When a pin terminal is produced by the production method, as compared with a conventional pin terminal which has the same total length, and in which the length from the tip end to the engagement portion is identical, therefore, the to-be-crimped portion which is formed to have the even outer diameter, and which is capable of being crimped is extended. Even when a shortish inner shaft is employed, therefore, the crimped portion which is actually crimped can be extended because of the to-be-crimped portion which is longer than a conventional one, and the inner shaft and the pin terminal are likely to be firmly coupled together.

[0022] In the pin terminal, moreover, reduction of the material can be sufficiently performed correspondingly with the configuration where a flange is not formed in the tip end of the large-diameter portion, and also reduction of the weight can be realized. A glow plug can employ such a pin terminal, and a shortish inner shaft can be employed. Also in a glow plug, therefore, reduction of the material can be sufficiently performed, and also reduction of the weight can be attained.

[0023] In the production method, moreover, a flange is not formed in the tip end of the large-diameter portion, and hence it is not necessary to employ a split die which is radially divided in the periphery of the large-diameter portion. According to the production method, therefore, the structure of the die is simplified, the production cost of the die can be lowered, and the durability of the die can be improved.

[0024] According to the production method of the invention, it is possible to economically produce a high-quality and light-weight pin terminal for a glow plug, and consequently a high-quality and light-weight glow plug.

[0025] In the production method of the invention, in at least one of the step of deforming the end surface, the step of deforming the rear end side and the step of deforming the third workpiece, a fitting recess to which a rear end portion of an inner shaft of the glow plug is fitted is formed in an end surface of the tip end side of the pin terminal. In this case, the steps which are performed until the processing of the fourth workpiece, including molding of the fitting recess are performed by a plastic working. Also during the molding of the fitting recess, therefore, swarf is not produced.

[0026] In this regard, in the case where the pin terminal is produced only by applying a cutting process to a workpiece, or where the formation of the fitting recess is produced by a cutting process, swarf is produced. Since there is a possibility that swarf may cause the inner shaft to be hardly fitted to the fitting recess, and that a short circuit may occur, swarf has to be removed away. However, this work for removing the swarf requires great labor. In a pin terminal which is obtained by employing a split die, furthermore, the large-diameter portion is liable to have radial buns, and the work of surely removing the burrs in order to prevent a situation where the burrs are peeled off to cause a short circuit, from occurring similarly requires great labor. In the production method, by contrast, the amount of swarf can be made minimum, and burrs are hardly produced. Even when labor of removing swarf and buns is not so much provided, therefore, the assembling property of the glow plug can be improved, and the short circuit caused by the pin terminal can be avoided.

[0027] When the steps of processing from the workpiece to the fourth workpiece through the second and third workpieces are performed by a plastic working, moreover, the process time in the process from the first workpiece to the fourth workpiece can be shortened. When the plastic working is performed as described above, for example, a large number of second workpieces can be simultaneously processed to third workpieces, and then to fourth workpieces. Therefore, pin terminals are easily mass produced. Because of these, when a pin terminal is produced as described above, reduction of the production cost thereof can be further realized, and consequently reduction of the production cost of a glow plug can be further realized.

[0028] In the production method, as described above, swarf is not produced during the molding of the fitting recess. Since, in the steps of processing from the first workpiece to the fourth workpiece, swarf due to the respective workpieces is not produced, the method can contribute to realization of further resource saving.

[0029] In the step of deforming the end surface, a first fitting recess having a first depth may be formed in an end surface on a tip end side of the first workpiece. In the step of deforming the rear end side, a second fitting recess having a second depth which is deeper than the first depth may be formed in an end surface on a tip end side of the second

workpiece. In the step of deforming the third workpiece, the fitting recess having a third depth which is deeper than the second depth may be formed in an end surface on a tip end side of the third workpiece.

[0030] In this case, in the first to third workpieces, the fitting recess is formed respectively in a plurality of steps so that its depth becomes deeper in the sequence from the first fitting recess to the fitting recess. Therefore, even when the shape of the first fitting recess formed in the first workpiece is deformed in the other subsequent steps, the shape can be corrected when the second fitting recess is formed in the second workpiece. According to the production method, therefore, the shapes of fitting recesses of produced pin terminals are easily homogenized.

[0031] The fitting recess may be configured by a cylindrical inner circumferential surface which extends from a tip end of the large-diameter portion toward a rear end, and an upper bottom surface which is continuous to a rear end of the inner circumferential surface. The upper bottom surface may have a tapered shape in which a diameter becomes smaller toward a rear end side.

[0032] According to the inventor's confirmation, because of an affection of plastic deformation of the third workpiece in the formation of the flange, strain or the like easily occurs in the upper bottom surface of the fitting recess, and wrinkles or the like caused by the strain are easily formed in the upper bottom surface. On the other hand, a plating process is applied to a pin terminal of a glow plug for the purpose of protection of the surface thereof. In the case where strain occurs in the upper bottom surface, therefore, a washing solution or the like which is used in the plating process remains in the wrinkles or the like in the upper bottom surface, and therefore the quality of plating in the fitting recess is liable to be lowered. Because of the affection of the remaining washing solution or the like, rust or the like is easily formed on the upper bottom surface. Because of these, the quality of a pin terminal is liable to be lowered.

[0033] Therefore, according to one aspect of the present invention, the upper bottom surface of the fitting recess is formed into a tapered shape in which the diameter becomes smaller toward the rear end side, whereby, in the third workpiece in which the fitting recess is formed, the thickness of the circumference of the upper bottom surface is made large. Therefore, the upper bottom surface is hardly (barely) deformed even by plastic deformation in the formation of the flange, and strain or the like hardly occurs in the upper bottom surface. Therefore, a washing solution or the like hardly remains on the upper bottom surface, and plating is satisfactorily applied to the fitting recess. Moreover, also rust or the like is hardly formed on the upper bottom surface. Because of these, the quality of a pin terminal is high.

[0034] Furthermore, it is preferable that the upper bottom surface is positioned on a tip end side of the fourth workpiece with respect to the maximum diameter position of the flange. The plastic deformation of the third workpiece in the formation of the flange is largest at the maximum diameter position of the flange. When the upper bottom surface of the fitting recess is positioned on the tip end side of the fourth workpiece with respect to the maximum diameter position of the flange, the influence of the plastic deformation on the upper bottom surface can be further reduced. Therefore, deformation of the upper bottom surface due to plastic deformation hardly occurs, and the pin terminal has a higher quality.

[0035] Preferably, the flange has: a first cylindrical surface which is positioned on a side of the small-diameter portion, which is larger in diameter than the small-diameter portion, and which is cylindrical; a convexly curved surface which is connected to the first cylindrical surface, and in which an axial section is arcuate, and a section in a direction perpendicular to an axis is circular; and a second cylindrical surface which is connected to the convexly curved surface, which is equal in diameter to the first cylindrical surface, and which is cylindrical. Preferably, the flange has: a first disk surface which is connected to the small-diameter portion, and which extends in the direction perpendicular to the axis; a tapered surface which is connected to the first disk surface, in which a rear end side has a smaller diameter, and which is connected to the first cylindrical surface; and a second disk surface which connects the second cylindrical surface to the large-diameter portion, and which extends in the direction perpendicular to the axis.

[0036] In these cases, the convexly curved surface or the tapered surface causes the cap to be easily fitted to the pin terminal. Moreover, the second cylindrical surface causes the cap engaged with the engagement portion to hardly slip off from the pin terminal.

[0037] In the production method of the invention, a first die having a first cavity which can mold a rear end side of the convexly curved surface, and a second die having a second cavity which can mold a tip end side of the convexly curved surface may be used. In the first die and the second die, preferably, a parting surface between the first cavity and the second cavity is on a tip end side with respect to the maximum diameter position, and a maximum diameter of the second cavity is smaller than a maximum diameter of the first cavity.

[0038] Because of the difference between the maximum diameter of the first cavity and that of the second cavity, in the convexly curved surface formed by the first die and the second die, the side having an arc directed from the parting surface to the first cylindrical surface, and that the side having an arc directed from the parting surface to the second cylindrical surface are different in diameter from each other, with the parting surface as the boundary. Because of the difference between the diameters, in the outer circumferential surface of the convexly curved surface, a step is formed on the tip end side with respect to the maximum diameter position. Therefore, the cap can be engaged with the step. In a pin terminal which is produced by the above-described production method, therefore, the cap can be satisfactorily fitted.

[0039] In the case of a pin terminal, in which another engagement portion is disposed on the tip end side of the pin terminal with respect to the step and the cap is to be engaged with the engagement portion, even when the cap is caused to be disengaged from the engagement portion by vibrations or the like, and the cap is moved in the direction along which the cap slips off from the pin terminal, the cap is caused to be engaged with the step. In such a pin terminal, namely, a state is attained where the cap is doubly engaged by the engagement portion and the step, the cap can be further satisfactorily fitted.

[0040] In the production method of the invention, the step is formed by using a diameter difference between the maximum diameter of the first cavity and the maximum diameter of the second cavity. Therefore, as compared with the case where a step is formed by a cutting process on the whole outer cir-

cumferential surface of the convexly curved surface, for example, production of swarf from the workpiece can be suppressed.

[0041] Preferably, the production method of the invention further has an outer diameter finishing step of finishing the outer diameter of the fourth workpiece by performing cutting or polishing in which a cutting depth is 1 mm or less, to form the pin terminal. In this case, the fourth workpiece can be produced in a relatively rough manner, and the production of the fourth workpiece is facilitated. Then, a pin terminal with higher accuracy can be produced by performing cutting or polishing on the fourth workpiece. When the cutting depth is 1 mm or less in this case, cutting swarf or polishing swarf caused by cutting or polishing can be reduced. Therefore, resource saving and reduction of the production cost can be realized without impairing the effects of the invention.

[0042] The method of producing a glow plug according to the invention is a method of producing a glow plug including: a cylindrical housing; a heater which is fixed into the housing, and which has a heating portion projecting from a tip end of the housing; a rod-like inner shaft which is placed in the housing, and in which a rear end portion projects from a rear end of the housing; and a pin terminal which is fitted to the rear end portion of the inner shaft, which is used for supplying electricity from an outside to the heating portion through the inner shaft, the method comprising:

[0043] obtaining a first workpiece which has a rod-like shape, and which is made of the conductive metal;

[0044] plastically deforming an end surface of a rear end side of the first workpiece into a curved surface shape, and setting to a second workpiece;

[0045] plastically deforming a rear end side of the second workpiece into a small-diameter portion which is configured to be fitted to a cap for supplying electricity from an outside, and plastically deforming a tip end side of the second workpiece into a large-diameter portion which is larger in diameter than the small-diameter portion to obtain a third workpiece; and

[0046] plastically deforming the third workpiece to form a flange between the small-diameter portion and the large-diameter portion, the flange being larger in outer diameter than the large-diameter portion, and an engagement portion formed between a position where a diameter of the flange is maximum and the large-diameter portion, an outer diameter of the engagement portion being gradually reduced toward the large-diameter portion, and the engagement portion being configured to be engaged with to obtain a fourth workpiece.

[0047] The glow plug which is obtained by the production method of the invention includes a pin terminal including the features of claim 1 above. The glow plug which is obtained by the production method is light weight and economical, and its durability is enhanced because the inner shaft and the pin terminal are fastened to each other with a crimping area which is larger than a conventional one owing to the extended crimped portion. Therefore, its durability is enhanced.

[0048] In the glow plug, as compared with a conventional glow plug, a portion of the inner shaft which projects from the rear end of the housing can be shortened, and the whole inner shaft can be shortened. Therefore, reduction of the weight of the glow plug can be realized.

[0049] According to the production method of the invention, therefore, a high-quality and light-weight glow plug can be economically produced.

[0050] According to the production method of the invention, a high-quality and light-weight pin terminal for a glow plug or glow plug can be economically produced.

BRIEF DESCRIPTION OF THE DRAWINGS

[0051] FIG. 1 is a sectional view of a glow plug of an embodiment.

[0052] FIGS. 2A and 2B relate to the glow plug of the embodiment, and is a partial cutaway sectional view and partial enlarged view showing a pin terminal which has not been assembled, FIG. 2A is a partial cutaway sectional view showing the entire pin terminal, and FIG. 2B is a partial enlarged view showing a convexly curved surface.

[0053] FIG. 3 relates to the glow plug of the embodiment, and is an enlarged sectional view showing a state of fitting of the pin terminal and a cap.

[0054] FIGS. 4A to 4E relate a production method of the embodiment, and are side views of a workpiece when each step is ended.

[0055] FIG. 5 relates the production method of the embodiment, and is a sectional view showing a second step.

[0056] FIG. 6 relates the production method of the embodiment, and is a sectional view showing a third step.

[0057] FIG. 7 relates the production method of the embodiment, and is a sectional view showing a fourth step.

[0058] FIG. 8 relates the production method of the embodiment, and is a sectional view showing a first die and a second die.

[0059] FIG. 9 relates the production method of the embodiment, and is a perspective view showing a punch.

[0060] FIG. 10 relates the production method of the embodiment, and is a sectional view showing an outer diameter finishing step.

[0061] FIG. 11 is a partial cutaway sectional view of a conventional glow plug, etc.

DETAILED DESCRIPTION OF PREFERRED EMBODIMENTS

[0062] Hereinafter, an embodiment in which the invention is embodied will be described with reference to the drawings.

[0063] As shown in FIG. 1, a glow plug of the embodiment includes: a metal shell 3 which is a cylindrical housing; a heater 5 which is fixed into the metal shell 3, and which has a heating portion 5a projecting from the tip end of the metal shell 3; a rod-like inner shaft 7 which is placed in the metal shell 3, and in which a rear end portion projects from the rear end of the metal shell 3; and a pin terminal 10 which is fitted to the rear end portion of the inner shaft 7, and which is used for supplying electricity from the outside to the heating portion 5a through the inner shaft 7.

[0064] The heater 5 has a heating tube 11 in which the tip end is closed, which has a tubular shape extending in the axial direction, and which is fixed in an electricity supplyable manner to the interior of the metal shell 3 in a state where a tip end portion of the heater 5 projects from the tip end side of the metal shell 3. The tip end of inner shaft 7 is positioned in the heating tube 11, and the rear end of inner shaft 7 projects from the rear end of the metal shell 3. Insulating powder 12 containing MgO as a major component, and a heating coil 13 are accommodated in the heating tube 11. In the heating coil 13, a tip end portion is joined to the tip end side of the heating tube 11, and a rear end portion is joined to a tip end portion of the inner shaft 7. The heater 5 is configured by the heating tube

11, the insulating powder **12**, and the heating coil **13**. The tip end side of the heating tube **11** in which the heating coil **13** is accommodated together with the insulating powder **12** is the heating portion **5a** of the heater **5**.

[0065] An insulating member **15** in the form of a rubber packing is fixed to a middle portion of the outer circumferential surface of the inner shaft **7**. The heating tube **11** is fixed in an insulating state to the inner shaft **7** by crimping the opening end of the heating tube **11** in the periphery of the insulating member **15**.

[0066] A large-diameter hole **3b** which has the largest diameter in a shaft hole **3a** is formed in the rear end side of the metal shell **3**. An O-ring **17** and an annular insulator **19** made of an insulating material are placed on a rear-end-directed step between the shaft hole **3a** and the large-diameter hole **3b**. The inner shaft **7** is passed through the inner circumferences of the O-ring **17** and the annular insulator **19**.

[0067] As shown in FIG. 2A, the pin terminal **10** has a small-diameter portion **10a** in the rear end side, and a large-diameter portion **10b** in the tip end side. The small-diameter portion **10a** has a shaft-like shape which extends in the axial direction. A curved surface **10c** is formed on the outer circumference of the end surface of the rear end side of the small-diameter portion **10a**. A flange **10d** is formed between the small-diameter portion **10a** and the large-diameter portion **10b**. The small-diameter portion **10a** and the large-diameter portion **10b** are separated from each other by the flange **10d**.

[0068] The flange **10d** has a first cylindrical surface **21**, a convexly curved surface **22**, and a second cylindrical surface **23**. The first cylindrical surface **21** is positioned on the side of the small-diameter portion **10a**, and has a cylindrical shape which is larger in diameter than the small-diameter portion **10a**. The convexly curved surface **22** is connected to the first cylindrical surface **21**, the axial section is arcuate, and a section in a direction perpendicular to the axis is circular. The second cylindrical surface **23** is connected to the convexly curved surface **22**, and has a cylindrical shape which is equal in diameter to the first cylindrical surface **21**.

[0069] The flange **10d** further has a first disk surface **21a**, a tapered surface **20**, and a second disk surface **23a**. The first disk surface **21a** is connected to the small-diameter portion **10a**, and extends in the direction perpendicular to the axis. The tapered surface **20** is connected in the tip end side to the first cylindrical surface **21**, and in the rear end side to the first disk surface **21a**. The tapered surface **20** is formed so that the rear end side has a smaller diameter. The second disk surface **23a** connects the second cylindrical surface **23** to the large-diameter portion **10b**, and extends in the direction perpendicular to the axis. The connecting portion between the second disk surface **23a** and the large-diameter portion **10b** has an arcuate shape. Therefore, the second disk surface **23a** and the large-diameter portion **10b** are smoothly connected to each other.

[0070] As shown in FIG. 2B, the convexly curved surface **22** is configured, with a place which is slightly on the tip end side with respect to the maximum diameter position MP of the flange **10d** as the boundary, by: a first arc **22a** that is directed from the place which is slightly on the tip end side with respect to the maximum diameter position MP, toward the first cylindrical surface **21**; and a second arc **22b** that is directed from the place which is slightly on the tip end side with respect to the maximum diameter position MP, toward the second cylindrical surface **23**. In other words, the side

having the first arc **22a** is the rear end side of the convexly curved surface **22**, and that the side having the second arc **22b** is the tip end side of the convexly curved surface **22**. A step **22c** is formed in the boundary between the first arc **22a** and the second arc **22b**, namely, in the outer circumferential surface of the convexly curved surface **22** in the place which is slightly on the tip end side with respect to the maximum diameter position MP. The formation of the step **22c** will be described later in detail.

[0071] As shown in FIG. 2A, the large-diameter portion **10b** is disposed integrally with the tip end of the small-diameter portion **10a**, and formed so that it is larger in outer diameter than the small-diameter portion **10a**, and smaller in outer diameter than the flange **10d**. In the large-diameter portion **10b**, an engagement portion **10e** is formed so that the outer diameter is gradually reduced toward the large-diameter portion **10b**, between the second cylindrical surface **23** of the flange **10d** and the large-diameter portion **10b**. The above-described step **22c** is positioned in the engagement portion **10e**. In the large-diameter portion **10b** of the pin terminal **10** before assembly, the outer circumferential surface excluding the engagement portion **10e**, i.e., the straight portion functions as a to-be-crimped portion **10f**. The engagement portion **10e** is requested to be between the maximum diameter position MP of the flange **10d** and the large-diameter portion **10b**, and not limited between the second cylindrical surface **23** and the large-diameter portion **10b**, and may be one portion of the convexly curved surface **22** which is on the tip end side with respect to the maximum diameter position MP, or in the second cylindrical surface **23** or the second disk surface **23a**.

[0072] Furthermore, a fitting recess **25** to which the inner shaft **7** is fitted is formed in the end surface of the tip end side of the large-diameter portion **10b**. The fitting recess **25** is configured in the pin terminal **10** by an inner circumferential surface **251** which extends from the tip end of the large-diameter portion **10b** toward the rear end, and an upper bottom surface **252** which is continuous to the rear end of the inner circumferential surface **251**, and which is positioned radially inside the flange **10d**. The upper bottom surface **252** has a tapered shape in which the diameter becomes smaller as advancing from the front end side of the pin terminal **10** toward the rear end side. The upper bottom surface **252** is positioned inside the pin terminal **10**, and on the side of the front end with respect to the maximum diameter position MP of the flange **10d**, more specifically in a place in the pin terminal **10** and corresponding to the second cylindrical surface **23**.

[0073] As shown in FIG. 3, a cap **97a** to which an electric current is to be supplied from the outside is attached to the pin terminal **10**. The cap **97a** has a cup-shaped cap body **970**, and an electric conductive member **87a** which is fixed to the inner side of the cap body **970**. The cap body **970** is made of a resin. An engaged portion **971** is formed inside the opening side of the cap body **970**. By contrast, the electric conductive member **87a** is connected to a lead wire **88a** which leads to a battery that is not shown.

[0074] In relation to production of the glow plug, the pin terminal **10** is produced by the following steps.

[0075] First Step

[0076] As shown in FIG. 4A, first, a rod member **30** in which $\phi D'$, which has a circular section, and which is made of a steel material that is an electric conductive metal is prepared. The rod member **30** is cut in the axis-perpendicular

direction to obtain a first workpiece 31 having a predetermined length, as shown in FIG. 4B.

[0077] Second Step

[0078] As shown in FIG. 5, an end-surface adjustment die 50 having a cavity 50a is prepared. The inner diameter of the cavity 50a is ϕD , and slightly larger than $\phi D'$. The inner diameter ϕD is substantially equal to the outer diameter of the large-diameter portion 10b of the pin terminal 10 shown in FIG. 2A.

[0079] As shown in FIG. 5, a curved surface 50e is formed in the upper end of the cavity 50a. A kickout pin 50b is disposed in the upper end of the cavity 50a, and a punch 50c is disposed in the lower end of the cavity 50a so as to be pressable in the cavity 50a. A convex portion 50d having a first height is disposed in the upper end surface of the punch 50c. The first height is a height corresponding to a first depth.

[0080] Then, the first workpiece 31 is conveyed into the cavity 50a of the end-surface adjustment die 50, and the first workpiece 31 is pressed by the punch 50c. In the first workpiece 31, therefore, the end surface on the rear end side is pressingly contacted with the kickout pin 50b and the curved surface 50e to be adjusted, and plastic worked.

[0081] As shown in FIG. 4C, in this way, the first workpiece 31 is formed into a second workpiece 32 which has a curved surface 32a in the end surface on the rear end side. Even when, in preparation of the first workpiece 31, convex-concave portions are formed in the end surface on the rear end side or the end surface is inclined, therefore, the convex-concave portions are not expanded by an extruding process or the like, and the obtained second workpiece 32 is not unintentionally deformed. In the end surface on the tip end side of the second workpiece 32, a first fitting recess 25a having the first depth is formed by the above-described convex portion 50d.

[0082] Thereafter, the punch 50c is lowered, and the second workpiece 32 is taken out from the end-surface adjustment die 50 by the kickout pin 50b.

[0083] Third Step

[0084] As shown in FIG. 6, then, an extrusion die 51 having a cavity 51a in which the upper side has a smaller diameter is prepared.

[0085] A curved surface 51e is formed in the upper end of the cavity 51a. A kickout pin 51b is disposed in the upper end of the cavity 51a, and a punch 51c is disposed in the lower end of the cavity 51a so as to be pressable in the cavity 51a. A convex portion 51d having a second height which is larger than the first height is disposed in the upper end surface of the punch 51c. The second height is a height corresponding to a second depth.

[0086] Then, the second workpiece 32 is conveyed into the cavity 51a of the extrusion die 51 so that the curved surface 32a is in the upper side, and the second workpiece 32 is pressed by the punch 51c. In the second workpiece 32, therefore, the end surface on the rear end side is again pressingly contacted with the kickout pin 51b and the curved surface 51e to be adjusted, and plastic worked.

[0087] As shown in FIG. 4D, in this way, the second workpiece 32 is formed into a third workpiece 33 in which the rear end side is reduced in diameter. In the third workpiece 33, the rear end side is formed into a small-diameter portion 33a of 4d, and the tip end side is formed into a large-diameter portion 33b which remains to have ϕD that is larger than 4d. The end surface of the small-diameter portion 33a is formed into the curved surface 10c which is the shape of a product, by causing

the curved surface 32a to have a smaller diameter. In the end surface of the tip end side of the third workpiece 33, a second fitting recess 25b having the second depth which is larger than the first depth is formed by the above-described convex portion 51d. Thereafter, the punch 51c is lowered, and the third workpiece 33 is taken out from the extrusion die 51 by the kickout pin 51b.

[0088] Fourth Step

[0089] In the fourth step, as shown in FIG. 7, a flange molding die 52 including a first die 52a and a second die 52b is prepared. The second die 52b is urged toward the first die 52a by a press spring 52f.

[0090] As shown in FIG. 8, a first cavity 52c matching with the small-diameter portion 10a shown in FIG. 2A, and the tapered surface 20, first cylindrical surface 21, and first arc 22a of the convexly curved surface 22 in the flange 10d is formed in the first die 52a. Namely, the rear end side starting from the first arc 22a of the flange 10d can be molded by the first cavity 52c. The first cavity 52c is formed so that, when the third workpiece 33 shown FIG. 4D is placed, the upper end of the small-diameter portion 33a is placed in the first die 52a. A curved surface 52i is formed in the upper end of the first cavity 52c.

[0091] On the other hand, a second cavity 52e matching with the second cylindrical surface 23 of the flange 10d shown in FIG. 2A, the second arc 22b in the convexly curved surface 22, and the large-diameter portion 10b is formed in the second die 52b. Namely, the tip end side starting from the second arc 22b of the flange 10d can be molded by the second cavity 52e.

[0092] As described above, in the pin terminal 10, here, the first arc 22a and the second arc 22b are formed on both sides, respectively, with a place which is slightly on the tip end side with respect to the maximum diameter position MP of the flange 10d, as the boundary (see FIG. 2B). In the first die 52a and the second die 52b, as shown in FIG. 8, namely, die divided surfaces 52j, 52k for the first cavity 52c and the second cavity 52e are positioned on the tip end side with respect to the maximum diameter position MP.

[0093] A first circular hole 521 matching with the side of the first arc 22a is formed in the die divided surface 52j in the first die 52a. Similarly, a second circular hole 522 matching with the side of the second arc 22b is formed in the die divided surface 52k in the second die 52b. The maximum diameter N of the second circular hole 522 is smaller than the maximum diameter M of the first circular hole 521.

[0094] As shown in FIG. 7, a kickout pin 52d is disposed in the upper end of the first cavity 52c. On the other hand, a punch 52g is disposed in the lower end of the second cavity 52e so as to be pressable in the second cavity 52e. As shown in FIG. 9, a convex portion 52h having a third height which is larger than the second height is disposed in the upper end surface of the punch 52g. The third height is a height corresponding to a third depth, and more specifically a height from the tip end side of the third workpiece 33 to a position corresponding to the second cylindrical surface 23 of the flange 10d. The convex portion 52h has a tapered shape in which the diameter is reduced toward its upper end surface 520. A knurling process is performed on the upper end surface 520 of the convex portion 52h.

[0095] As shown in FIG. 7, the third workpiece 33 is conveyed into the first and second cavities 52c, 52e of the first die 52a and the second die 52b so that the small-diameter portion 33a is in the upper side, namely on the side of the first die 52a, and the third workpiece 33 is pressed by the punch 52g. In the

third workpiece 33, therefore, the end surface on the rear end side is pressingly contacted with the kickout pin 52*d* and the curved surface 52*i* to be adjusted, and plastically worked. As shown in FIG. 4E, in this way, the third workpiece 33 is formed into a fourth workpiece 34.

[0096] In the fourth workpiece 34, the rear end side is a small-diameter portion 34*a* which is identical with the small-diameter portion 33*a* of the third workpiece 33. Moreover, the flange 10*d* is formed between a large-diameter portion 34*b* which is identical with the large-diameter portion 33*b* of the third workpiece 33, and the small-diameter portion 34*a*. At this time, because of the difference between the maximum diameter M of the first circular hole 521 in the first cavity 52*c* and the maximum diameter N of the second circular hole 522 in the second cavity 52*e*, the step 22*c* is formed in the outer circumferential surface which is slightly on the tip end side with respect to the maximum diameter position MP of the flange 10*d*. The step 22*c* has a shape declining toward the tip end side of the convexly curved surface 22 (the tip end side of the fourth workpiece 34). On the other hand, the end surface of the small-diameter portion 34*a* remains to be the curved surface 10*c*. In the end surface of the tip end side of the fourth workpiece 34, a third fitting recess 25*c* having the third depth which is larger than the second depth is formed by the above-described convex portion 52*h*.

[0097] Thereafter, the punch 52*g* and the second die 52*b* are lowered, and the fourth workpiece 34 is taken out from the flange molding die 52 by the kickout pin 52*d*. The small-diameter portion 34*a* formed in the fourth workpiece 34 corresponds to the small-diameter portion 10*a* shown in FIG. 2A. Similarly, the large-diameter portion 34*b* formed in the fourth workpiece 34 corresponds to the large-diameter portion 10*b* shown in FIG. 2A, and the third fitting recess 25*c* corresponds to the fitting recess 25 shown in FIG. 2A.

[0098] Outer Diameter Finishing Step

[0099] In the outer diameter finishing step, an outer diameter finishing apparatus 54 including a stationary die 54*a* and a cutter 54*b* as shown in FIG. 10 is prepared.

[0100] A cavity 54*c* for accommodating the small-diameter portion 34*a* of the fourth workpiece 34 is formed in the stationary die 54*a*. A curved surface 54*f* is formed in the upper end of the cavity 54*c*. A kickout pin 54*d* is disposed in the upper end of the cavity 54*c*. The cutter 54*b* is formed into a cylindrical shape, and disposed so as to be vertically movable. The cutter 54*b* has a blade portion 54*e* in the outer circumference of the tip end, so that the outer circumferential side of the flange 10*d* of the fourth workpiece 34 is cut by the blade portion 54*e*.

[0101] Then, the fourth workpiece 34 is conveyed into the cavity 54*c* of the stationary die 54*a* so that the small-diameter portion 34*a* is in the upper side, and the cutter 54*b* cuts away the outer circumferential side of the flange 10*d* of the fourth workpiece 34. At this time, the cutting degree with respect to the outer circumferential side of the flange 10*d* is $\phi 1$ mm or less. Therefore, the outer diameter of the flange 10*d* can be made constant, and its roundness can be enhanced. After the cutting process on the outer circumferential side of the flange 10*d* of the fourth workpiece 34 is ended, the fourth workpiece 34 is taken out from the stationary die 54*a* by the kickout pin 52*d*. Finally, a plating process is applied to the fourth workpiece 34 by a known method. In this way, the pin terminal 10 shown in FIG. 2A is obtained.

[0102] On the other hand, as shown in FIG. 1, the metal shell 3, the heating tube 11, the insulating member 15, the

heating coil 13, the inner shaft 7, the O-ring 17, the insulator 19, and the like are prepared. While electrically connecting required places of these components to one another, these components and the pin terminal 10 are assembled together by a known method. In this case, in the rear end side of the insulator 19, the to-be-crimped portion 10*f* (see FIG. 2A) of the pin terminal 10 is actually crimped in a state where the rear end portion of the inner shaft 7 is fitted to the fitting recess 25. As shown in FIG. 1, therefore, the inner shaft 7 and the pin terminal 10 are joined together. Furthermore, a crimped portion 10*g* is formed on the outer circumferential surface of the large-diameter portion 10*b*. In this way, the glow plug is completed.

[0103] In the thus obtained glow plug, the heating portion 5*a* of the heater 5 is located in a combustion chamber of a diesel engine by screwing a male thread 3*c* of the metal shell 3 to a cylinder head of the diesel engine. Then, the metal shell 3 is grounded to the cylinder head, and the cap 97*a* shown in FIG. 3 is fitted to the pin terminal 10.

[0104] When the cap 97*a* is pressingly put on the pin terminal 10 from the direction of the arrow shown in the figure, a state is attained where the engaged portion 971 is engaged with the engagement portion 10*e* and the cap 97*a* is fitted to the pin terminal 10. In this state, the electric conductive member 87*a* is connected to the small-diameter portion 10*a*, thereby allowing electricity to be supplied to the pin terminal 10 through the electric conductive member 87*a*, and consequently to the glow plug.

[0105] Therefore, a voltage is applied between the metal shell 3, and the pin terminal 10 and the inner shaft 7, and the heating portion 5*a* in the heater 5 is heated by the heating coil 13. Therefore, starting of the diesel engine is initiated.

[0106] In the method of producing a glow plug of the embodiment, when the pin terminal 10 is to be produced, as described above, the fourth workpiece which has the flange 10*d* between the small-diameter portion 10*a* and the large-diameter portion 10*b*, and in which a flange is not formed in the tip end of the large-diameter portion 10*b* is produced. In the pin terminal 10 which is obtained by the production method, as compared with a conventional pin terminal which has the same total length, and in which the length from the tip end to the engagement portion 10*e* is identical, therefore, the to-be-crimped portion 10*f* (the above-described straight portion) which is formed to have the even outer diameter, and which is capable of being crimped is extended. In a glow plug which is obtained by the production method, therefore, the shortish inner shaft 7 can be employed as compared with a conventional glow plug. Even in such a case, the crimped portion 10*g* which is actually crimped is extended because of the to-be-crimped portion 10*f* which is longer than a conventional one, and the inner shaft 7 and the pin terminal 10 are easily firmly coupled together. Moreover, the extended crimped portion 10*g* enables the inner shaft 7 and the pin terminal 10 to be fastened to each other with a crimping area which is larger than a conventional one. Therefore, the durability of the glow plug is enhanced.

[0107] In the pin terminal 10 disposed in the glow plug, the material can be sufficiently reduced by an amount corresponding to the non-formation of a flange in the tip end of the large-diameter portion 10*b*, and also reduction of the weight is attained. Since the shortish inner shaft 7 can be employed as described above, reduction of the material can be sufficiently performed, and also reduction of the weight can be attained.

[0108] In the pin terminal 10 which is obtained by the production method, a flange is not formed in the tip end of the large-diameter portion 10b, and hence it is not necessary to employ a split die which is radially divided in the periphery of the large-diameter portion 10b, in the production of the pin terminal 10. According to the production method, therefore, the structure of the die is simplified, the production cost of the die can be lowered, and the durability of the die can be improved.

[0109] According to the production method of the embodiment, therefore, it is possible to economically produce the high-quality and light-weight pin terminal 10 for a glow plug, and consequently a high-quality and light-weight glow plug.

[0110] In the production method for the pin terminal 10, particularly, all the steps of processing the workpiece 30 made of a conductive metal from the first workpiece 31 to the fourth workpiece 34, including the formation of the fitting recess 25 are performed by a plastic working. In the production method, in the production of the pin terminal 10, therefore, swarf is not produced in the first to fourth workpieces 31 to 34. In the production method, therefore, the amount of swarf in the production of the pin terminal 10 can be made minimum. Furthermore, a split die is not used as described above, and hence burrs are hardly produced in the first to fourth workpieces 31 to 34. Because of these, even when countermeasures for removing swarf and burrs are not so taken in the pin terminal 10, the assemblability of the glow plug is improved, and it is possible to avoid occurrence of a short circuit caused by the pin terminal 10.

[0111] When the process steps from the first workpiece to the fourth workpiece through the second and third workpieces are performed by a plastic working as described above, also the process time in the process from the first workpiece 31 to the fourth workpiece 34 can be shortened. When a plastic working is performed as described above, it is possible that many second workpieces 32 can be simultaneously processed to respective third workpieces 33 and consequently fourth workpieces 34. Therefore, pin terminals 10 are easily mass produced. Because of these, when the pin terminal 10 is produced as described above, reduction of the production cost thereof can be further realized, and consequently reduction of the production cost of a glow plug can be further realized.

[0112] In this case, in the steps of processing from the first workpiece 31 to the fourth workpiece 34, swarf due to the respective workpieces 32 to 34 is not produced, and hence the method can contribute to realization of further resource saving.

[0113] In the production method, when the pin terminal 10 is to be produced, the first fitting recess 25a having the first depth is formed in the end surface on the tip end side of the first workpiece 31 in the second step. The second fitting recess 25b having the second depth which is deeper than the first depth is formed in the end surface on the tip end side of the second workpiece 32 in the third step. In the fourth step, then, the fitting recess 25 (the third fitting recess 25c) having the third depth which is deeper than the second depth is formed in the end surface on the tip end side of the third workpiece 33.

[0114] In the production method, as described above, the fitting recess 25 is formed in the second to fourth workpieces 32 to 34 in the plurality of steps so that its depth becomes deeper in the sequence from the first fitting recess 25a to the fitting recess 25 (the third fitting recess 25c). In the production method, therefore, even when the shape of the first fitting recess 25a formed in the first workpiece 31 is changed in the

other subsequent steps, for example, the shape can be corrected when the second fitting recess 25b is formed in the second workpiece 32. According to the production method, therefore, the shapes of the fitting recesses 25 of produced pin terminals 10 are easily homogenized. The qualities of glow plugs are easily homogenized.

[0115] When the molding of the fitting recess 25 is divided into the plurality of steps as described above, the convex portions 50d, 51d, 52h which are disposed respectively in the punches 50c, 51c, 52g can have the first to third heights corresponding to the first to third depths, respectively. In the respective pressings of the second to fourth workpieces 32 to 34 by the punches 50c, 51c, 52g, therefore, the burdens on the convex portions 50d, 51d, 52h can be reduced. Therefore, the durabilities of the punches 50c, 51c, 52g can be enhanced.

[0116] As shown in FIG. 2A, here, the fitting recess 25 in the pin terminal 10 is configured by the cylindrical inner circumferential surface 251 which extends from the tip end of the large-diameter portion 10b toward the rear end, and the upper bottom surface 252 which is continuous to the rear end of the inner circumferential surface 251. As shown in FIG. 9, the convex portion 52h of the punch 52g has the tapered shape in which the diameter becomes smaller toward the upper end surface 520. Therefore, the upper bottom surface 252 of the formed fitting recess 25 has the tapered shape in which the diameter becomes smaller toward the rear end side of the pin terminal 10. The fitting recess 25 has the third depth. Therefore, the upper bottom surface 252 is positioned in the place in the pin terminal 10 and corresponding to the second cylindrical surface 23.

[0117] In the fourth step for obtaining the pin terminal 10, in the third workpiece 33 in which the third fitting recess 25c is formed, namely, the thickness of the circumference of the upper bottom surface 252 is made large. Therefore, the upper bottom surface (corresponding to the upper bottom surface 252 of the fitting recess 25) of the third fitting recess 25c is hardly deformed even by plastic deformation in the formation of the flange 10d, and strain or the like hardly occurs in the upper bottom surface 252. Although the plastic deformation of the third workpiece 33 is largest at the maximum diameter position MP of the flange 10d, the upper bottom surface 252 is positioned at the place which is on the tip end side with respect to the maximum diameter position MP of the flange 10d, and, in the obtained fourth workpiece 34, deformation of the upper bottom surface 252 due to plastic deformation therefore hardly occurs. In the fourth workpiece 34, because of these, strain or wrinkles or the like caused by the strain hardly occur in the upper bottom surface 252, and a washing solution or the like which is used in the plating process hardly remains in the upper bottom surface 252. In the pin terminal 10, therefore, a state where plating is satisfactorily applied to the fitting recess 25 is attained. In the pin terminal 10, moreover, also rust or the like is hardly formed on the upper bottom surface 252.

[0118] Furthermore, a knurling process is performed on the upper end surface 520 of the convex portion 52h of the punch 52g. During the pressurization on the third workpiece 33 by the punch 52g, therefore, the convex portion 52h hardly slips in the second fitting recess 25b, and the third fitting recess 25c can be satisfactorily formed. Because of these, the quality of the pin terminal 10 is high.

[0119] The flange 10d has the first cylindrical surface 21, the convexly curved surface 22, and the second cylindrical surface 23. The flange 10d further has the first disk surface

21a, the tapered surface 20 which is connected to the first disk surface 21 a and the first cylindrical surface 21, and the second disk surface 23a which connects the second cylindrical surface 23 to the large-diameter portion 10b. In the outer circumferential surface of the convexly curved surface 22 of the flange 10d, moreover, the step 22c is formed in the place which is slightly on the tip end side with respect to the maximum diameter position MP.

[0120] Because of these, the cap 97a is easily fitted to the pin terminal 10, and the cap 97a engaged with the engagement portion 10e hardly slips off from the pin terminal 10. Specifically, the cap 97a is attached to the pin terminal 10 while the cap 97a is pressed in the direction of the arrow shown in FIG. 3, whereby the engaged portion 971 of the cap body 970 is elastically deformed so as to expand along the first disk surface 21a and the tapered surface 20, and reaches the convexly curved surface 22. Then, the engaged portion 971 is elastically deformed so as to further expand along the first arc 22a, and reaches the maximum diameter position MP. After passing through the maximum diameter position MP, the engaged portion 971 moves along the step 22c and the second arc 22b, so that, while elastically deformed so as to be narrowed, the engaged portion reaches the engagement portion 10e through the second cylindrical surface 23. Then, the engaged portion 971 is engaged with the engagement portion 10e. In this way, the direction of attaching the cap 97a to the pin terminal 10, and the tapered surface 20 and the first arc 22a extend along each. Therefore, the cap 97a can be easily fitted to the pin terminal 10.

[0121] On the other hand, even when the engaged portion 971 is disengaged from the engagement portion by vibrations of the diesel engine or the like, and the cap 97a is moved in the direction along which it slips off from the pin terminal 10, i.e., the direction opposite to the arrow in the figure, the engaged portion 971 is caught by the above-described step 22c, and caused in situ to be engaged with the step 22c. Even when the engaged portion 971 is elastically expandingly deformed by the movement along the second arc 22b, namely, the engaged portion 971 abuts against the step 22c to be disabled to expand larger than the second arc 22b, and cannot override the step 22c to reach toward the first arc 22a. As a result, the engaged portion 971 is engaged with the step 22c as described above. In the pin terminal 10, as described above, the state where the cap 97a is doubly engaged with the engagement portion 10e and the step 22c is attained, and hence the cap 97a can be fitted to the pin terminal 10 more satisfactorily.

[0122] In the fourth step, moreover, the step 22c is formed by using the diameter difference between the maximum diameter M of the first circular hole 521 in the first cavity 52c and the maximum diameter N of the second circular hole 522 in the second cavity 52e. Therefore, as compared with the case where the step 22c is formed by performing a cutting process on the whole outer circumferential surface of the convexly curved surface 22, for example, production of swarf from the fourth workpiece 34 can be suppressed.

[0123] In the production method, when the pin terminal 10 is to be produced, the outer diameter finishing step of finishing the outer diameter of the fourth workpiece by cutting with 1 mm or less in depth to form the pin terminal 10 is performed. Therefore, the fourth workpiece 34 can be produced in a relatively rough manner, so that the production of the fourth workpiece 34 is facilitated. The pin terminal 10 with higher accuracy can be produced by performing cutting on the fourth

workpiece 34. In this case, when the cutting depth is 1 mm or less, the amount of swarf caused by cutting can be reduced.

[0124] Therefore, resource saving and reduction of the production cost can be realized without impairing the effects of the invention.

[0125] Although in the above the invention has been described with reference to the embodiment, the invention is not limited to the above-described embodiment. It is a matter of course that the invention can be applied while being adequately modified without departing from the spirit of the invention.

[0126] In the glow plug, for example, a housing made of a resin may be employed in place of the metal shell 3.

[0127] In the embodiment, the heating tube 11, the insulating powder 12, and the heating coil 13 constitute the heater 5. However, a ceramic heater may be used as the heater.

[0128] In the outer diameter finishing step, the pin terminal 10 may be finished by polishing in place of cutting. Also in this case, the polishing extent in polishing with respect to the outer circumferential side of the flange 10d is set to ϕ 1 mm or less. Similarly with the case of cutting, therefore, the amount of swarf caused by polishing can be reduced. In the outer diameter finishing step, a portion of the fourth workpiece 34 other than the outer circumferential side of the flange 10d may be cut or polished.

[0129] The punches 50c, 51c may have the same configuration as the punch 52g except the lengths of the convex portions 50d, 51d. In this case, even in the case where the first fitting recess 25a or the second fitting recess 25b is to be formed, the convex portions 50d, 51d are caused to hardly slide with respect to the first and second workpieces 31, 32 by the knurling process performed on the upper end surfaces of the convex portions 50d, 51d, and the first fitting recess 25a or the second fitting recess 25b can be satisfactorily formed.

DESCRIPTION OF REFERENCE NUMERALS AND SIGNS

- [0130] 3 . . . metal shell (housing)
- [0131] 5a . . . heating portion
- [0132] 5 . . . heater
- [0133] 7 . . . inner shaft
- [0134] 10 . . . pin terminal
- [0135] 31 . . . first workpiece
- [0136] 32 . . . second workpiece
- [0137] 97 . . . cap
- [0138] 10a, 33a, 34a . . . small-diameter portion
- [0139] 10b, 33b, 34b . . . large-diameter portion
- [0140] 33 . . . third workpiece
- [0141] 10d . . . flange
- [0142] MP . . . maximum diameter position
- [0143] 10e . . . engagement portion
- [0144] 34 . . . fourth workpiece
- [0145] 25, 25a to 25c . . . fitting recess (25a . . . first fitting recess, 25b . . . second fitting recess, 25c . . . third fitting recess)
- [0146] 21 . . . first cylindrical surface
- [0147] 22 . . . convexly curved surface
- [0148] 23 . . . second cylindrical surface
- [0149] 21a . . . first disk surface
- [0150] 20 . . . tapered surface
- [0151] 23a . . . second disk surface
- [0152] 52c . . . first cavity

1. A method of producing a pin terminal for a glow plug the method comprising:

obtaining a first workpiece which has a rod-like shape, and which is made of the conductive metal;
 plastically deforming an end surface of a rear end side of the first workpiece into a curved surface shape to obtain a second workpiece;
 plastically deforming a rear end side of the second workpiece into a small-diameter portion which is configured to be fitted to a cap for supplying electricity from an outside, and plastically deforming a tip end side of the second workpiece into a large-diameter portion which is larger in diameter than the small-diameter portion, to obtain a third workpiece; and
 plastically deforming a flange between the small-diameter portion and the large-diameter portion, the flange being larger in outer diameter than the large-diameter portion, and an engagement portion formed between a position where a diameter of the flange is maximum and the large-diameter portion, an outer diameter of the engagement portion being gradually reduced toward the large-diameter portion, and the engagement portion being configured to be engaged with the cap to obtain a fourth workpiece.

2. The method according to claim 1, wherein, in at least one of the step of deforming the end surface, the step of deforming the rear end side and the step of deforming the third workpiece, a fitting recess to which a rear end portion of an inner shaft of the glow plug is fitted is formed in an end surface of the tip end side of the pin terminal.

3. The method according to claim 2, wherein,
 in the step of deforming the end surface, a first fitting recess having a first depth is formed in an end surface on a tip end side of the first workpiece,
 in the step of deforming the rear end side, a second fitting recess having a second depth which is deeper than the first depth is formed in an end surface on a tip end side of the second workpiece, and,
 in the step of deforming the third workpiece, the fitting recess having a third depth which is deeper than the second depth is formed in an end surface on a tip end side of the third workpiece.

4. The method according to claim 2 or 3, wherein the fitting recess is configured by a cylindrical inner circumferential surface which extends from a tip end of the large-diameter portion toward a rear end, and an upper bottom surface which is continuous to a rear end of the inner circumferential surface, and

the upper bottom surface has a tapered shape in which a diameter becomes smaller toward a rear end side.

5. The method according to claim 4, wherein the upper bottom surface is positioned on a tip end side of the fourth workpiece with respect to the maximum diameter position of the flange.

6. The method according to claim 1, wherein the flange has: a first cylindrical surface which is positioned on a side of the small-diameter portion, which is larger in diameter than the small-diameter portion; a convexly curved surface which is connected to the first cylindrical surface, and in which an axial section is arcuate, and a section in a direction perpendicular to an axis is circular; and a second cylindrical surface

which is connected to the convexly curved surface, which is equal in diameter to the first cylindrical surface.

7. The method according to claim 6, wherein the flange has: a first disk surface which is connected to the small-diameter portion, and which extends in the direction perpendicular to the axis; a tapered surface which is connected to the first disk surface, in which a rear end side has a smaller diameter, and which is connected to the first cylindrical surface; and a second disk surface which connects the second cylindrical surface to the large-diameter portion, and which extends in the direction perpendicular to the axis.

8. The method according to claim 5, wherein a first die having a first cavity which can mold a rear end side of the convexly curved surface, and a second die having a second cavity which can mold a tip end side of the convexly curved surface are used, and,

in the first die and the second die, a parting surface between the first cavity and the second cavity is on a tip end side of the pin terminal with respect to the maximum diameter position, and a maximum diameter of the second cavity is smaller than a maximum diameter of the first cavity.

9. The method according to claim 1, further comprising finishing the fourth workpiece by performing cutting or polishing the outer diameter of the fourth workpiece by 1 mm or less, to form the pin terminal.

10. A method of producing a glow plug including: a cylindrical housing; a heater which is fixed into the housing, and which has a heating portion projecting from a tip end of the housing; a rod-like inner shaft which is placed in the housing, and in which a rear end portion projects from a rear end of the housing; and a pin terminal which is fitted to the rear end portion of the inner shaft, which is used for supplying electricity from an outside to the heating portion through the inner shaft, the method comprising:

obtaining a first workpiece which has a rod-like shape, and which is made of the conductive metal;

plastically deforming an end surface of a rear end side of the first workpiece into a curved surface shape, and setting to a second workpiece;

plastically deforming a rear end side of the second workpiece into a small-diameter portion which is configured to be fitted to a cap for supplying electricity from an outside, and plastically deforming a tip end side of the second workpiece into a large-diameter portion which is larger in diameter than the small-diameter portion, to obtain a third workpiece; and

plastically deforming the third workpiece to form a flange between the small-diameter portion and the large-diameter portion, the flange being larger in outer diameter than the large-diameter portion, and an engagement portion formed between a position where a diameter of the flange is maximum and the large-diameter portion, an outer diameter of the engagement portion being gradually reduced toward the large-diameter portion, and the engagement portion being configured to be engaged with to obtain a fourth workpiece.

* * * * *