



US00991281B2

(12) **United States Patent**
Yun et al.

(10) **Patent No.:** **US 9,991,281 B2**
(45) **Date of Patent:** **Jun. 5, 2018**

(54) **SEMICONDUCTOR DEVICES AND METHODS OF MANUFACTURING THE SAME**

(51) **Int. Cl.**
H01L 29/788 (2006.01)
H01L 27/11582 (2017.01)
(Continued)

(71) Applicant: **SAMSUNG ELECTRONICS CO., LTD.**, Suwon-si, Gyeonggi-do (KR)

(52) **U.S. Cl.**
CPC .. H01L 27/11582 (2013.01); **H01L 21/28273** (2013.01); **H01L 21/28282** (2013.01);
(Continued)

(72) Inventors: **Ju-Mi Yun**, Pocheon-si (KR);
Young-Jin Noh, Suwon-si (KR);
Kwang-Min Park, Seoul (KR);
Jae-Young Ahn, Seongnam-si (KR);
Guk-Hyon Yon, Hwaseong-si (KR);
Dong-Chul Yoo, Seongnam-si (KR);
Joong-Yun Ra, Seoul (KR);
Young-Seon Son, Hwaseong-si (KR);
Jeon-Il Lee, Suwon-si (KR);
Hun-Hyeong Lim, Hwaseong-si (KR)

(58) **Field of Classification Search**
USPC 257/314-326, E27.078, E29.3-E29.309,
257/255-266, E21.179-E21.182,
(Continued)

(73) Assignee: **SAMSUNG ELECTRONICS CO., LTD.**, Suwon-si, Gyeonggi-Do (KR)

(56) **References Cited**
U.S. PATENT DOCUMENTS
7,977,735 B2 7/2011 Lai et al.
8,426,302 B2 4/2013 Matsushita et al.
(Continued)

(*) Notice: Subject to any disclaimer, the term of this patent is extended or adjusted under 35 U.S.C. 154(b) by 0 days. days.

FOREIGN PATENT DOCUMENTS

KR 1020030084110 11/2003
KR 100652433 11/2006

(21) Appl. No.: **15/671,370**

Primary Examiner — Tram H Nguyen

(22) Filed: **Aug. 8, 2017**

(74) *Attorney, Agent, or Firm* — F. Chau & Associates, LLC

(65) **Prior Publication Data**
US 2017/0358596 A1 Dec. 14, 2017

(57) **ABSTRACT**

Related U.S. Application Data

A semiconductor device is provided as follows. A tunnel insulation layer is disposed on a substrate. The tunnel insulation layer includes a first silicon oxide layer, a second silicon oxide layer, and a silicon layer interposed between the first silicon oxide layer and the second silicon oxide layer. The silicon layer has a thickness smaller than a thickness of each of the first silicon oxide layer and the second silicon oxide layer. A gate pattern is disposed on the tunnel insulation layer.

(62) Division of application No. 14/963,987, filed on Dec. 9, 2015, now Pat. No. 9,754,959.

(30) **Foreign Application Priority Data**

Dec. 10, 2014 (KR) 10-2014-0177547

13 Claims, 31 Drawing Sheets

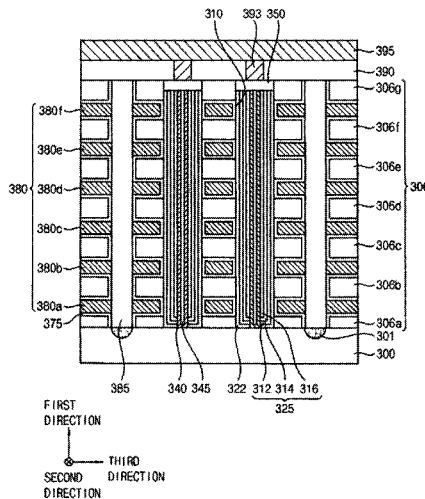

- (51) **Int. Cl.**
H01L 21/28 (2006.01)
H01L 29/51 (2006.01)
H01L 27/11556 (2017.01)
- (52) **U.S. Cl.**
CPC *H01L 27/11556* (2013.01); *H01L 29/513*
(2013.01); *H01L 29/518* (2013.01); *H01L*
29/7883 (2013.01)
- (58) **Field of Classification Search**
USPC 257/E21.209–21.21, E21.422, E21.423,
257/E21.679–E21.694, 68–71, 296–309,
257/905–908, E27.084–E27.097, E27.075,
257/E21.645–E21.694
See application file for complete search history.

(56) **References Cited**

U.S. PATENT DOCUMENTS

9,406,574	B1 *	8/2016	Byun	H01L 22/26
2003/0203113	A1	10/2003	Cho et al.		
2003/0203572	A1	10/2003	Yoshino		
2006/0033146	A1	2/2006	Wang		
2007/0054448	A1	3/2007	Choi et al.		
2007/0247923	A1	10/2007	Ding et al.		
2008/0173930	A1	7/2008	Watanabe et al.		
2009/0101967	A1	4/2009	Lai et al.		
2009/0179252	A1	7/2009	Baek et al.		
2010/0155821	A1	6/2010	Lai et al.		
2011/0001183	A1 *	1/2011	Yoo	H01L 21/02145 257/324
2012/0319172	A1	12/2012	Ramaswamy et al.		
2013/0087849	A1	4/2013	Meotto et al.		
2014/0167133	A1	6/2014	Hirano et al.		
2016/0172372	A1	6/2016	Yun et al.		

* cited by examiner

FIG. 1

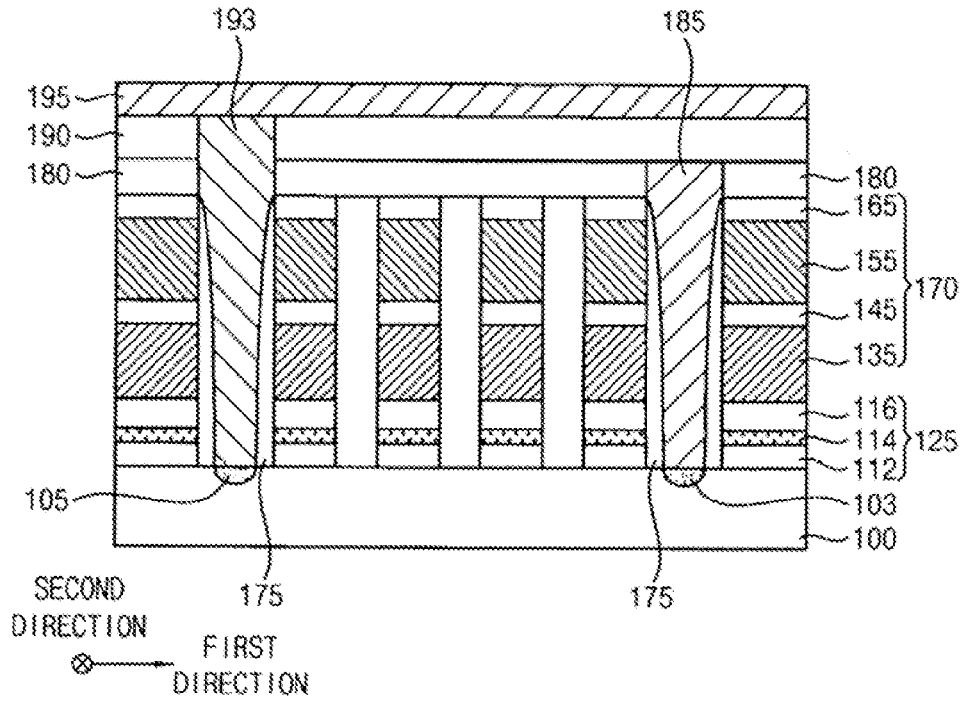

FIG. 2

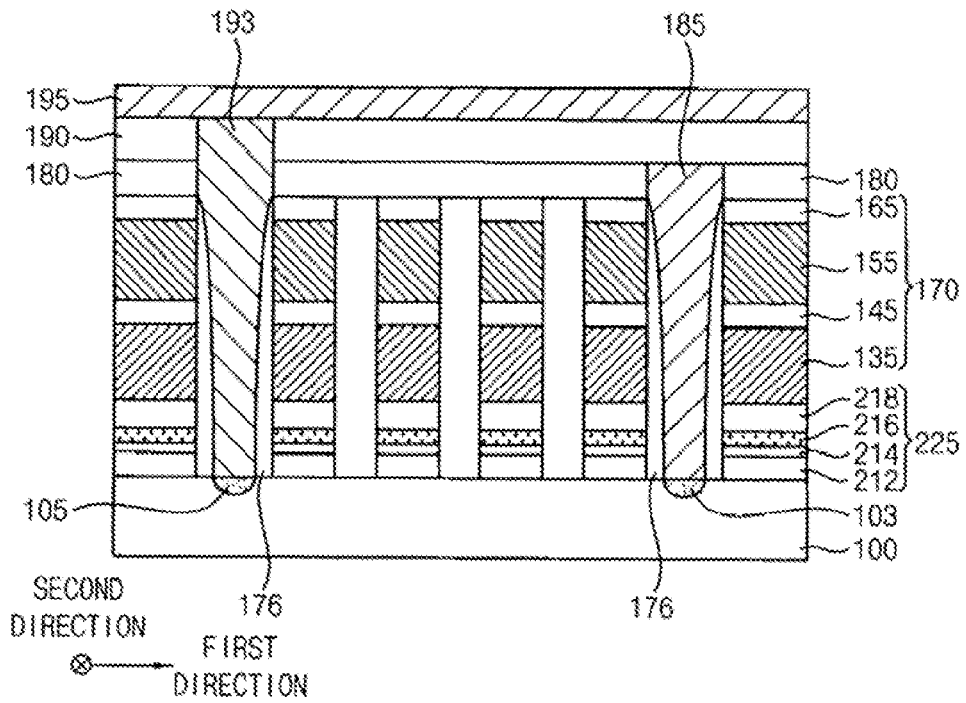

FIG. 3

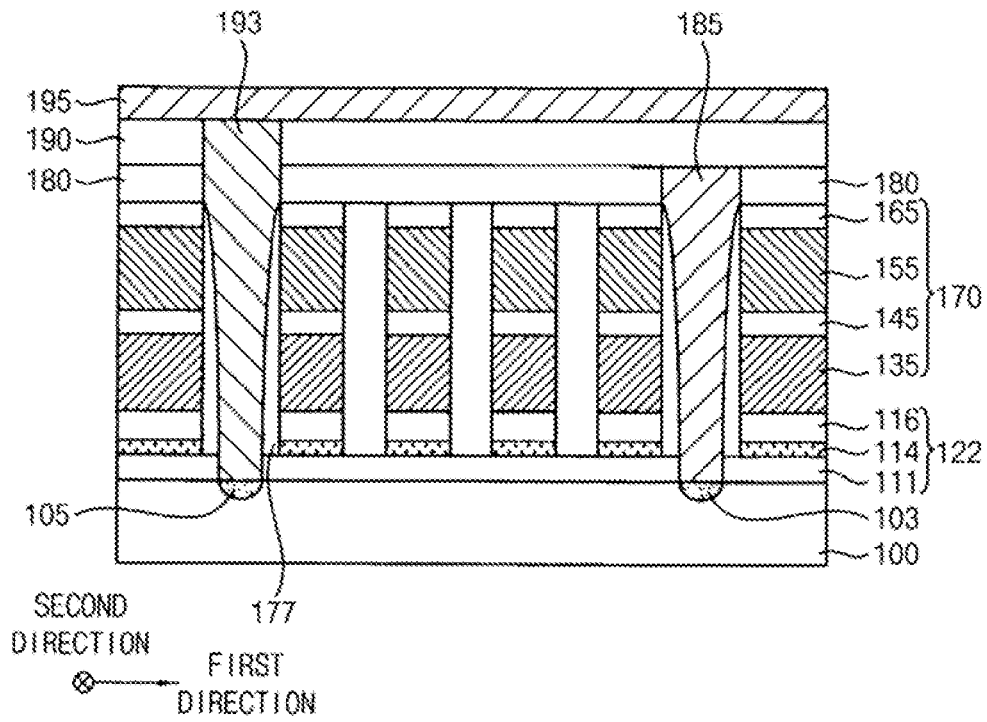

FIG. 4

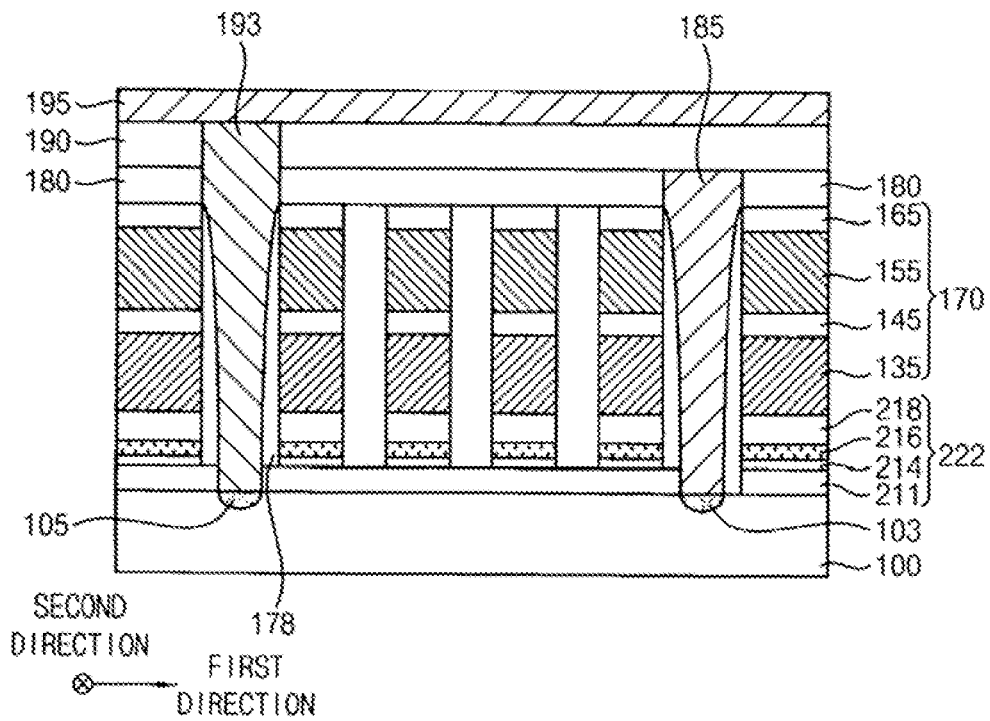

FIG. 5

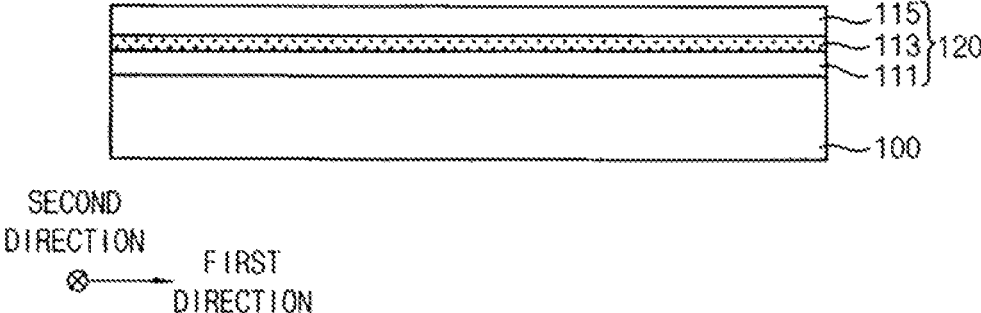

FIG. 6

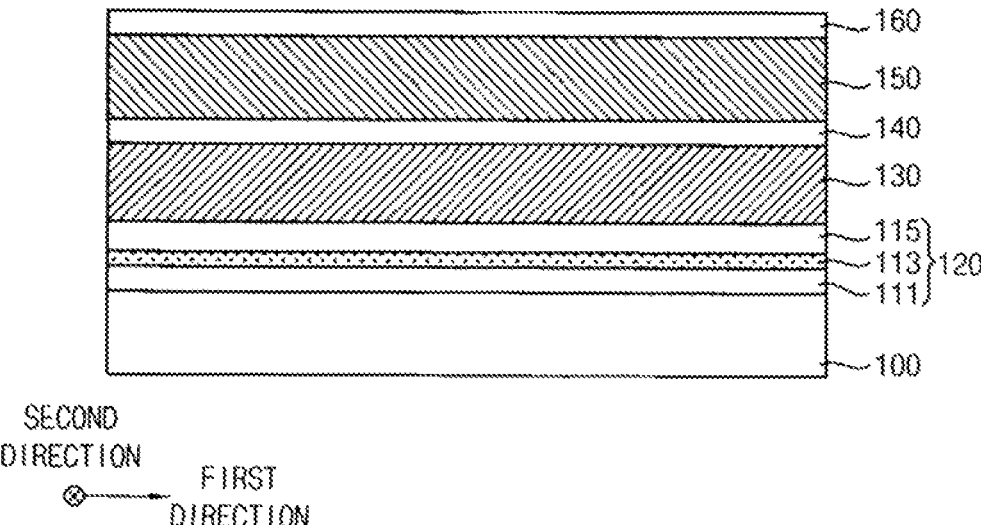

FIG. 7

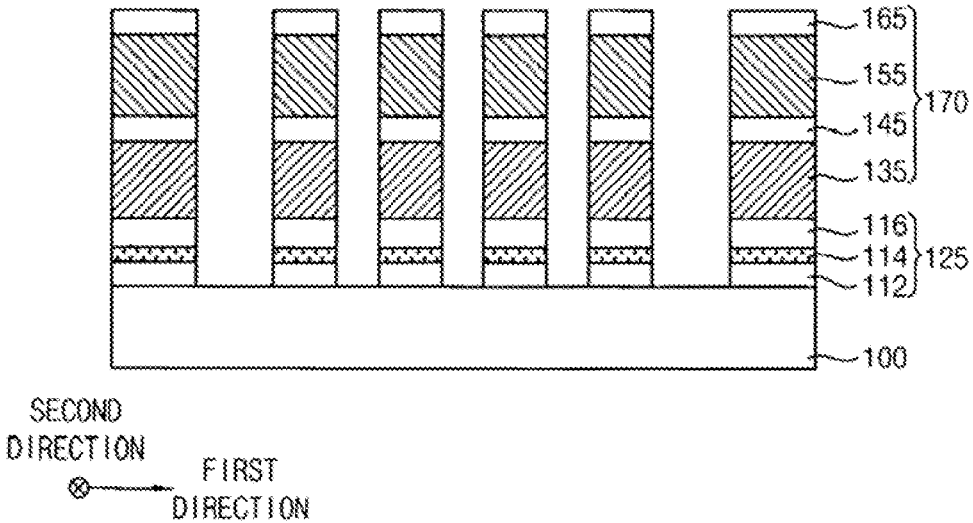

FIG. 8

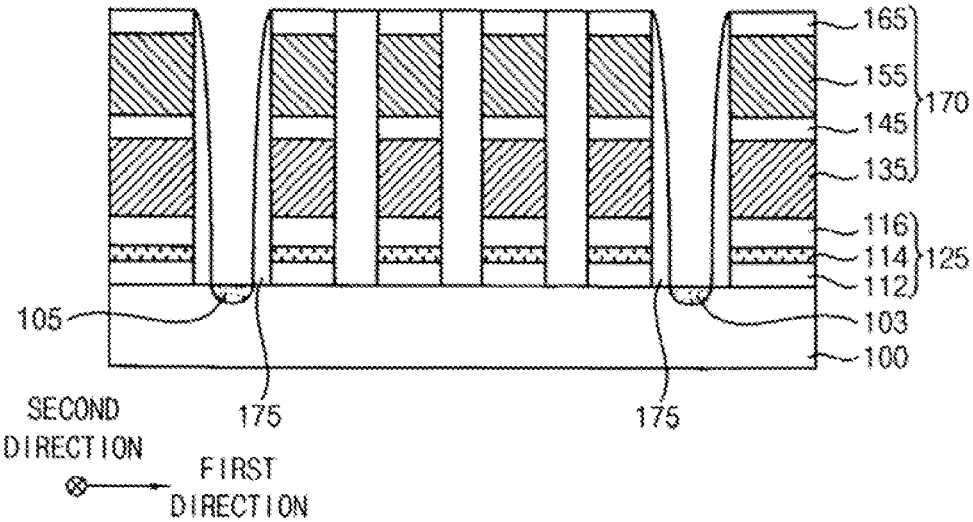

FIG. 9

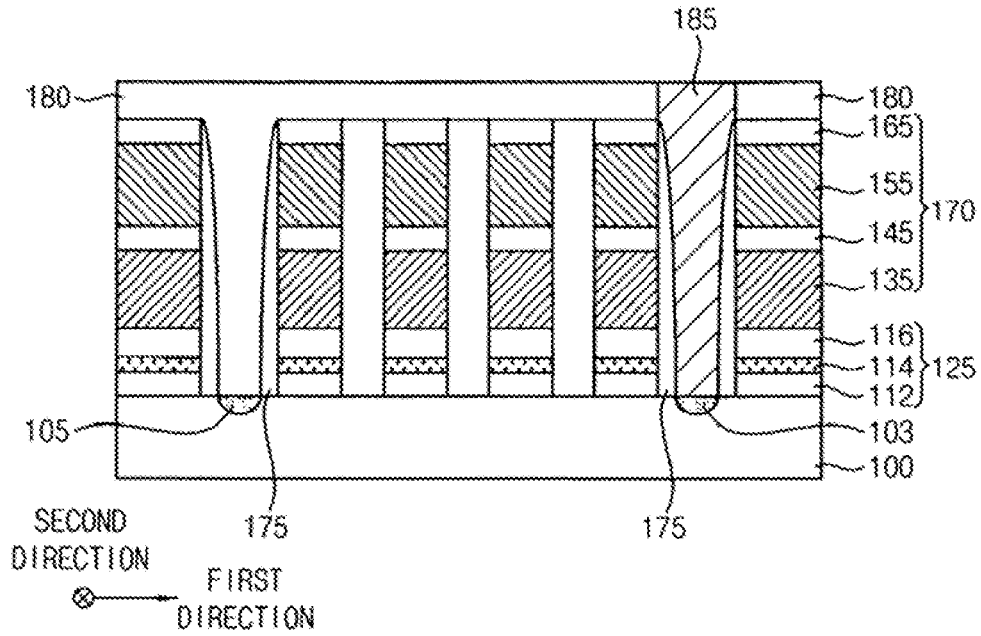

FIG. 10

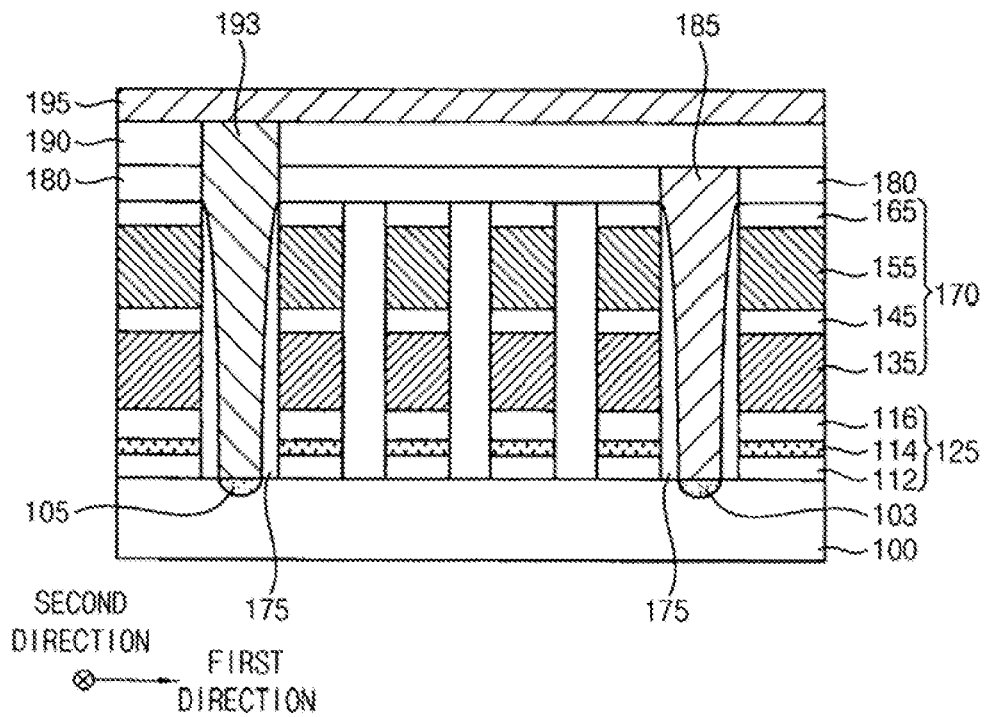

FIG. 11

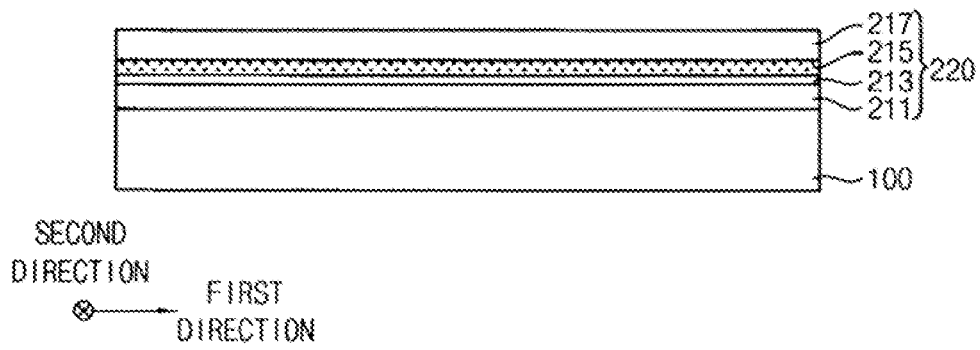

FIG. 12

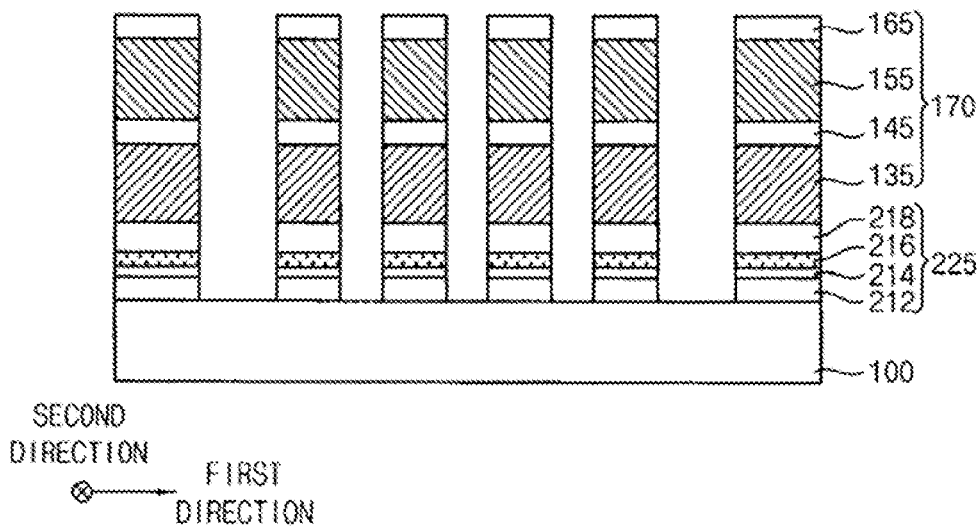

FIG. 13

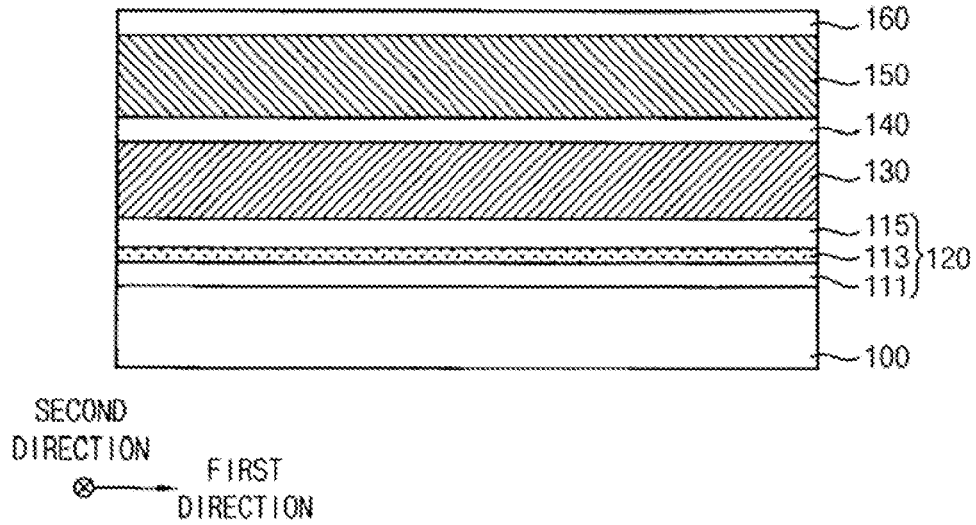

FIG. 14

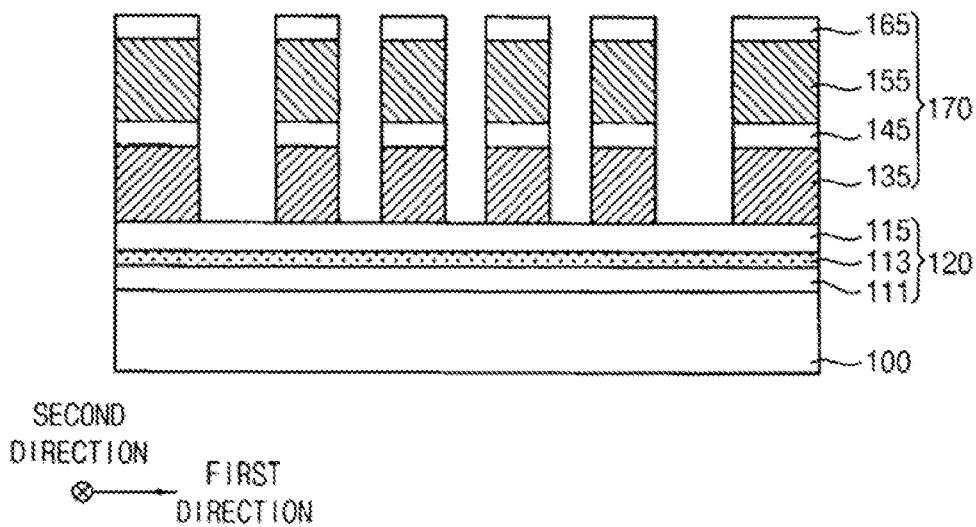

FIG. 15

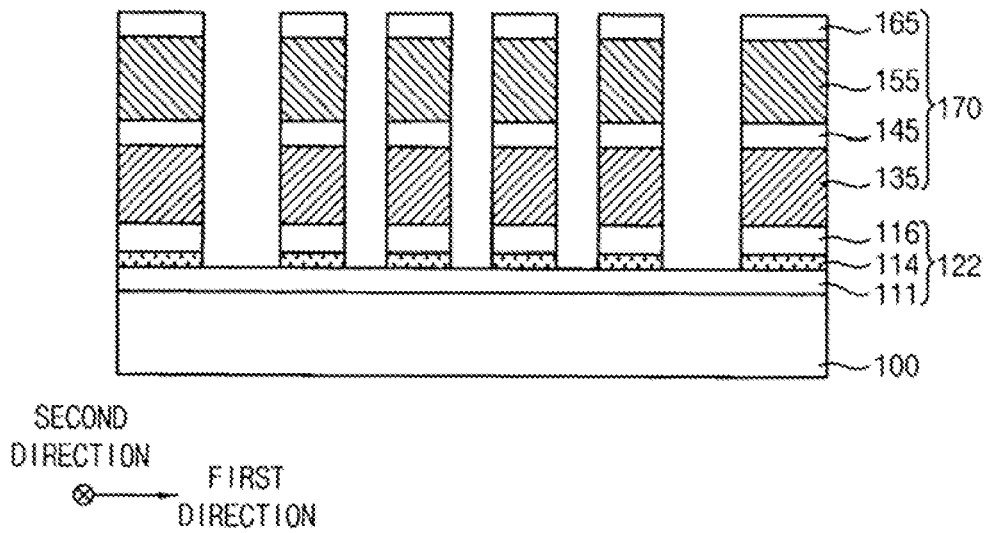

FIG. 16

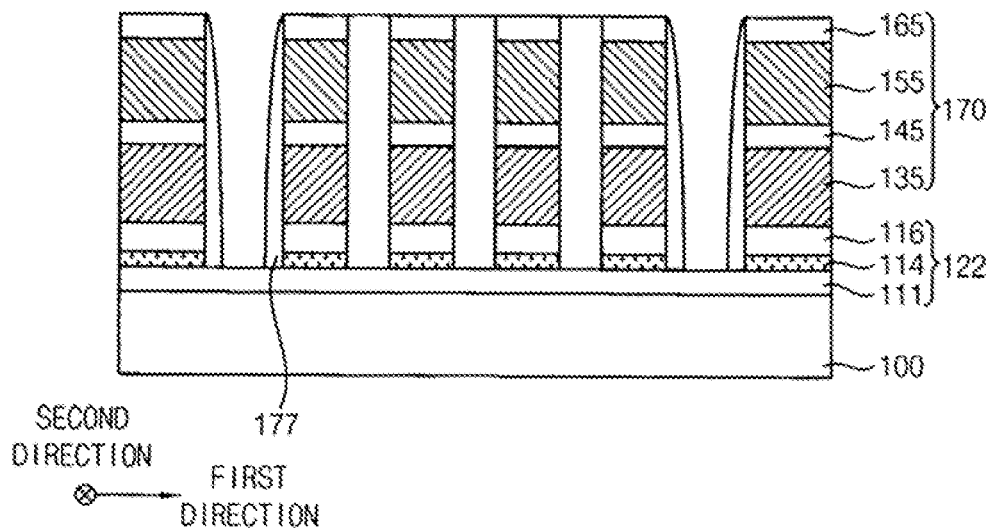

FIG. 19

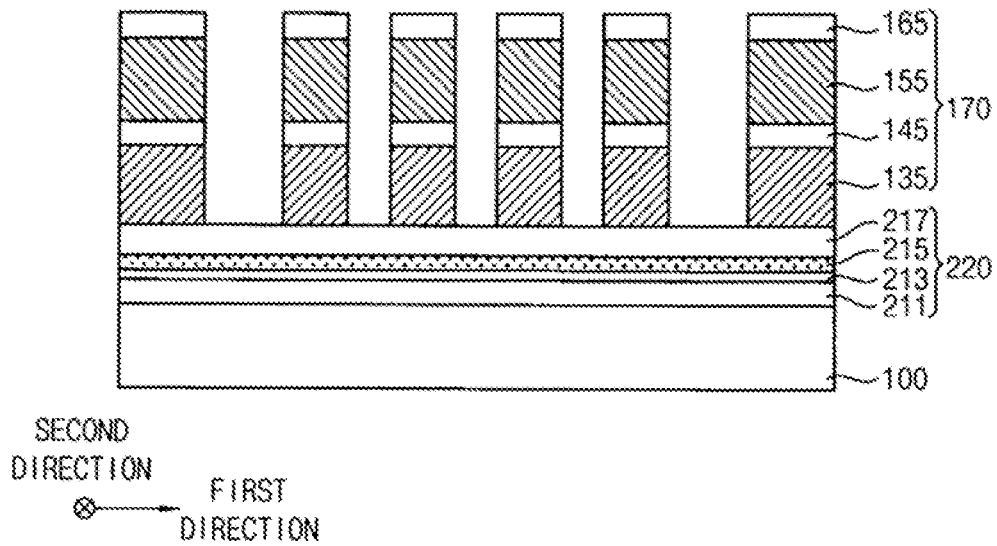

FIG. 20

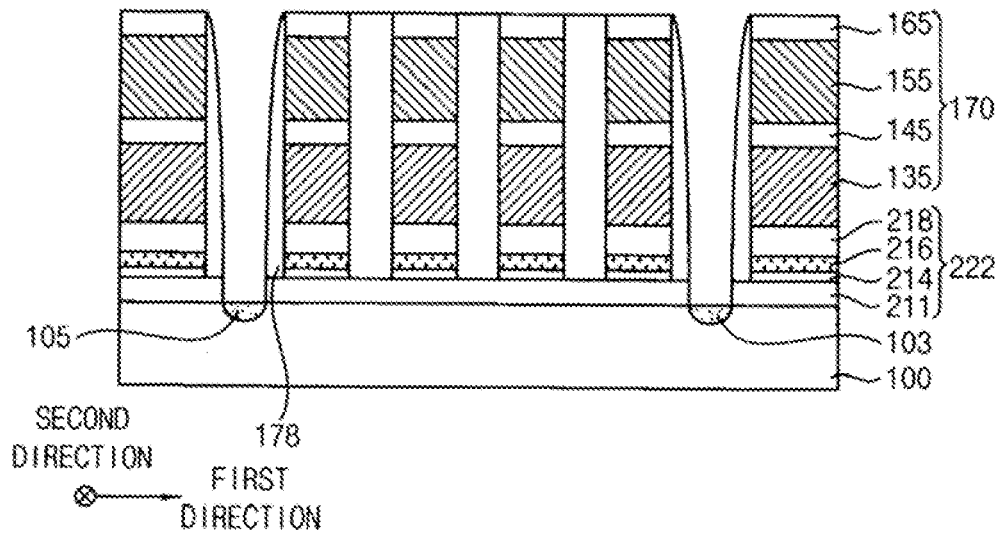

FIG. 21

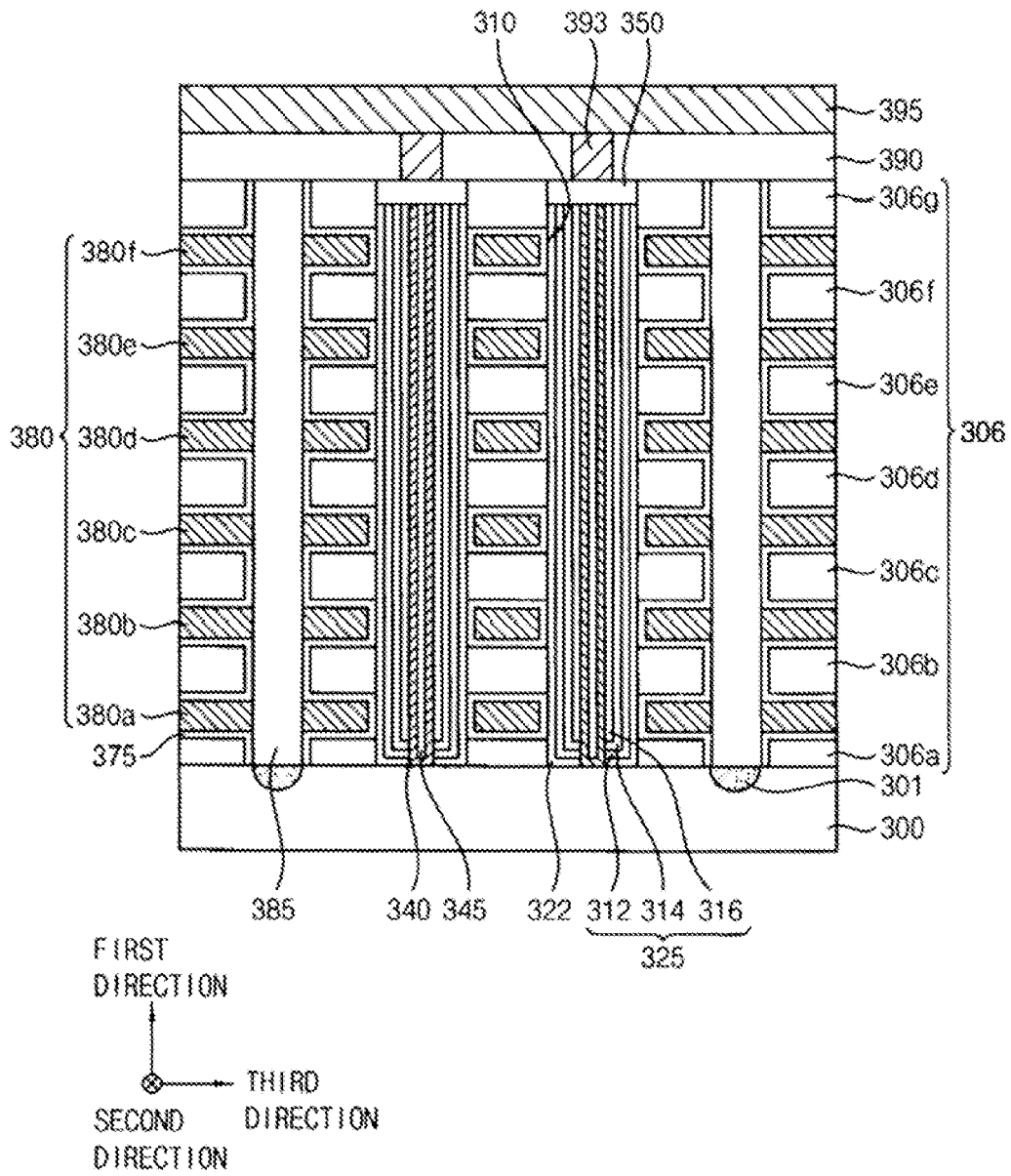

FIG. 22

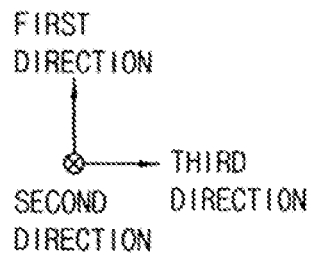
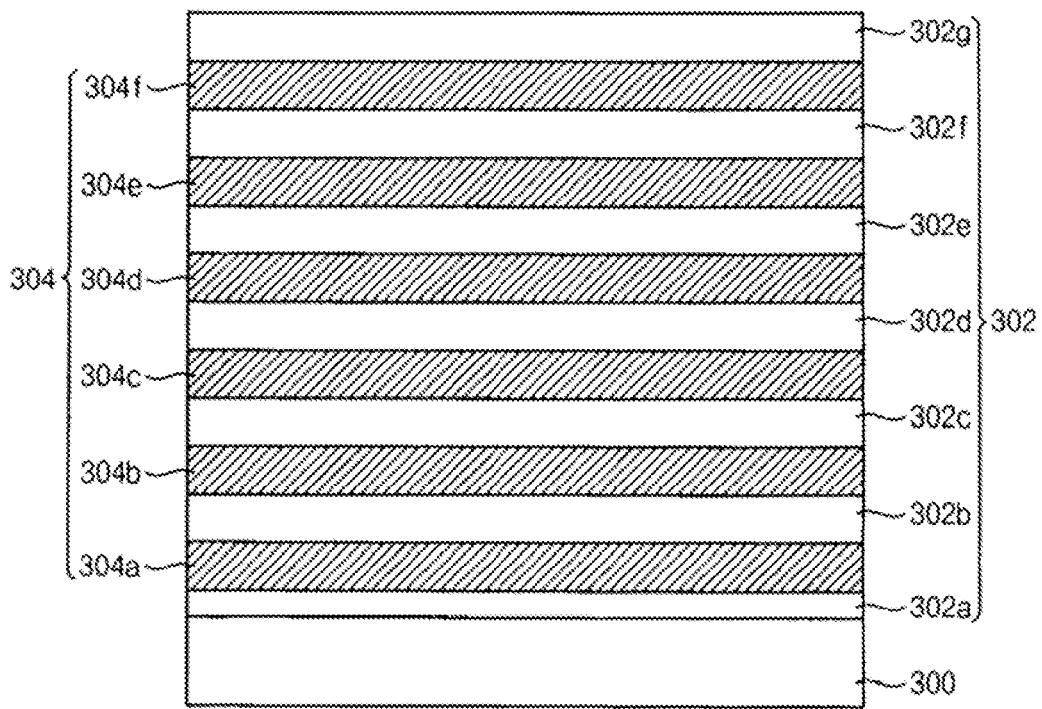

FIG. 23

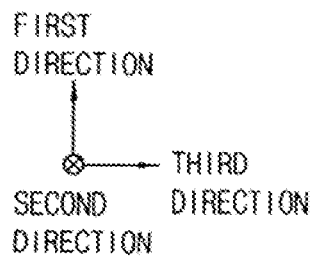
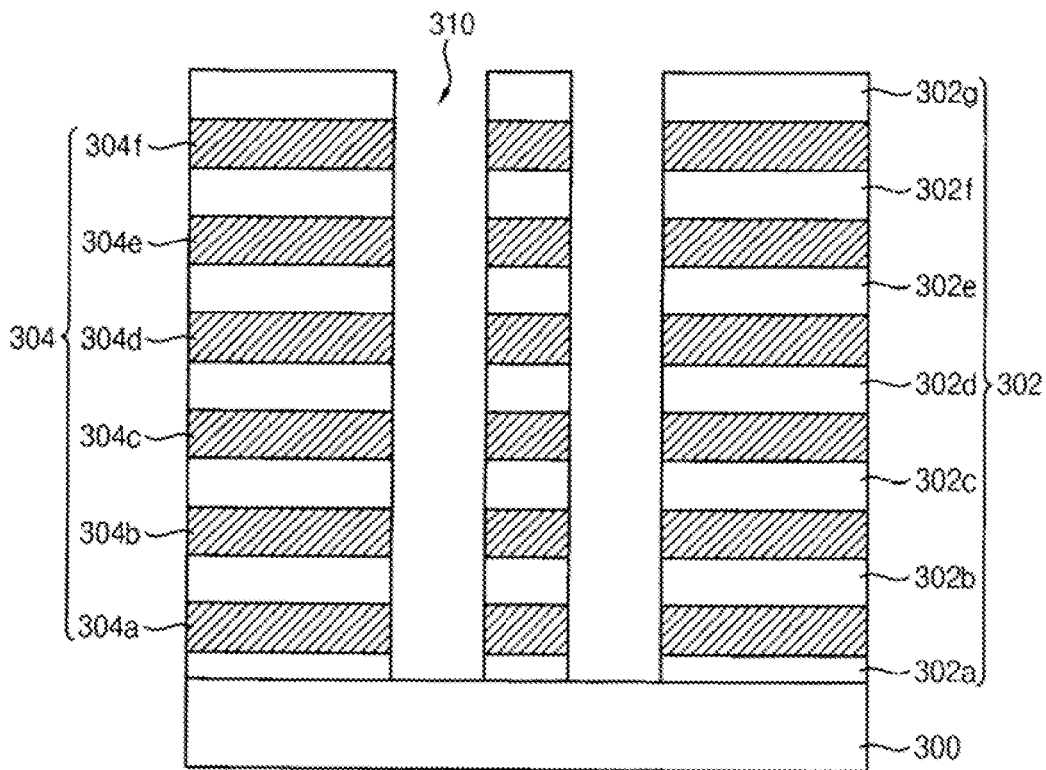

FIG. 24

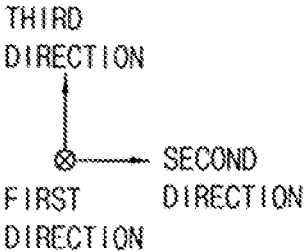
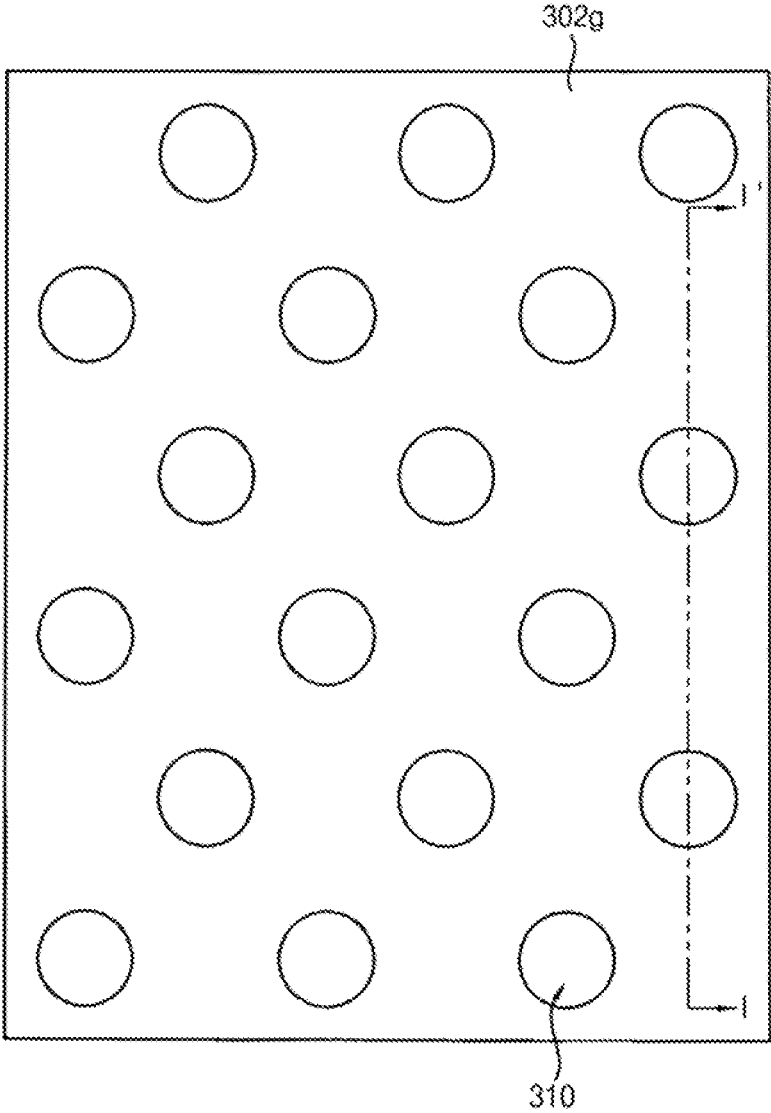

FIG. 25

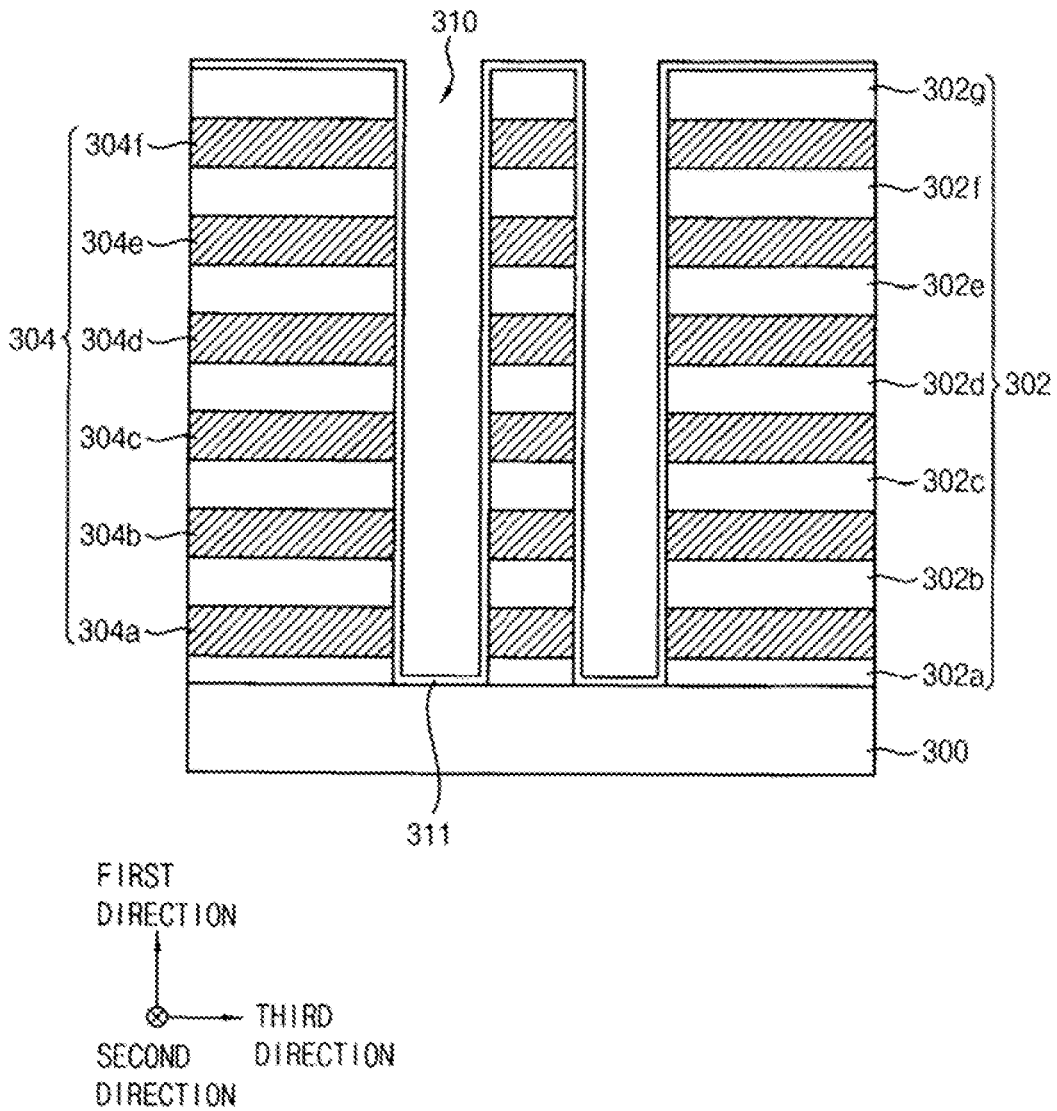

FIG. 26

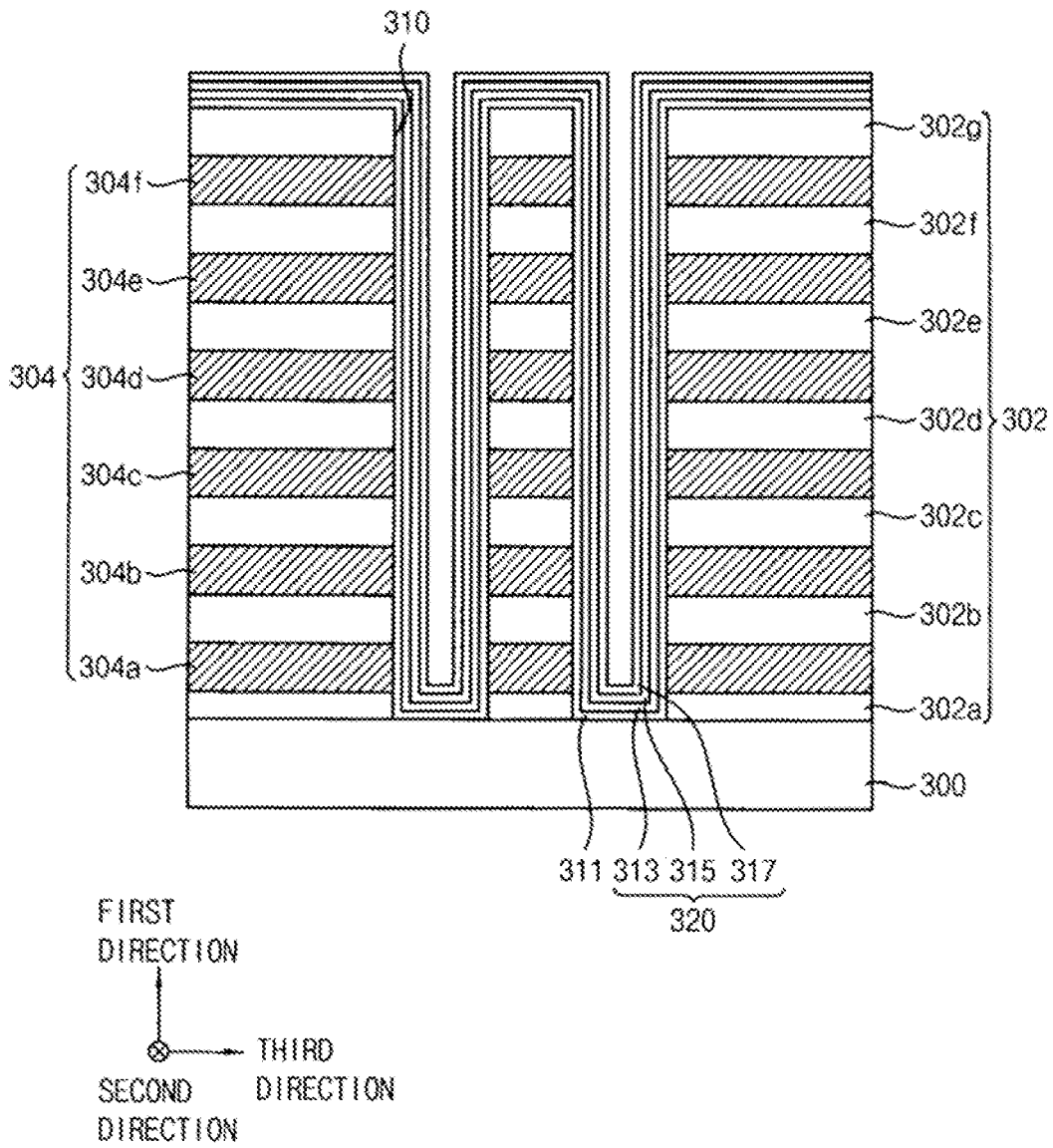

FIG. 27

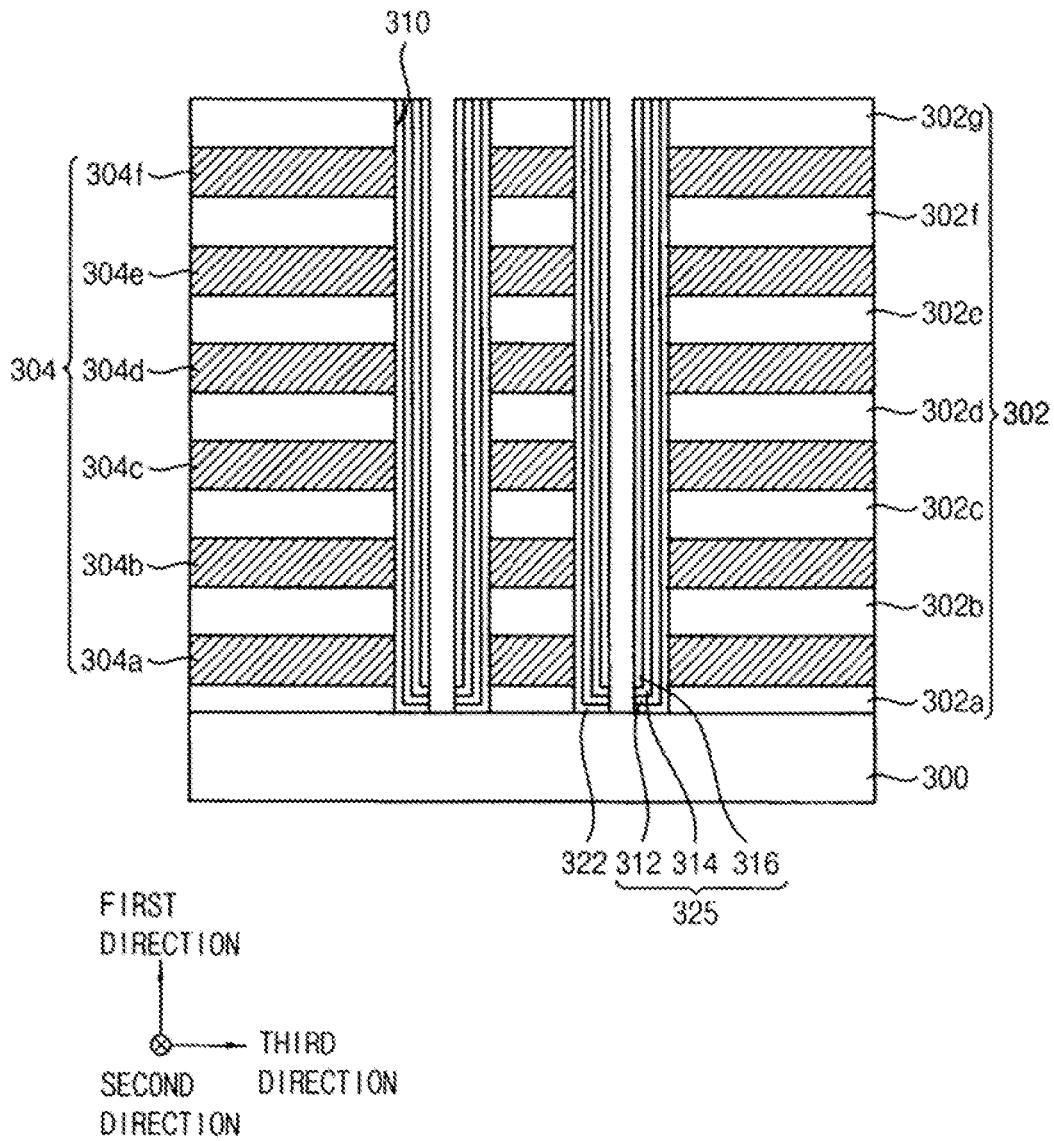

FIG. 28

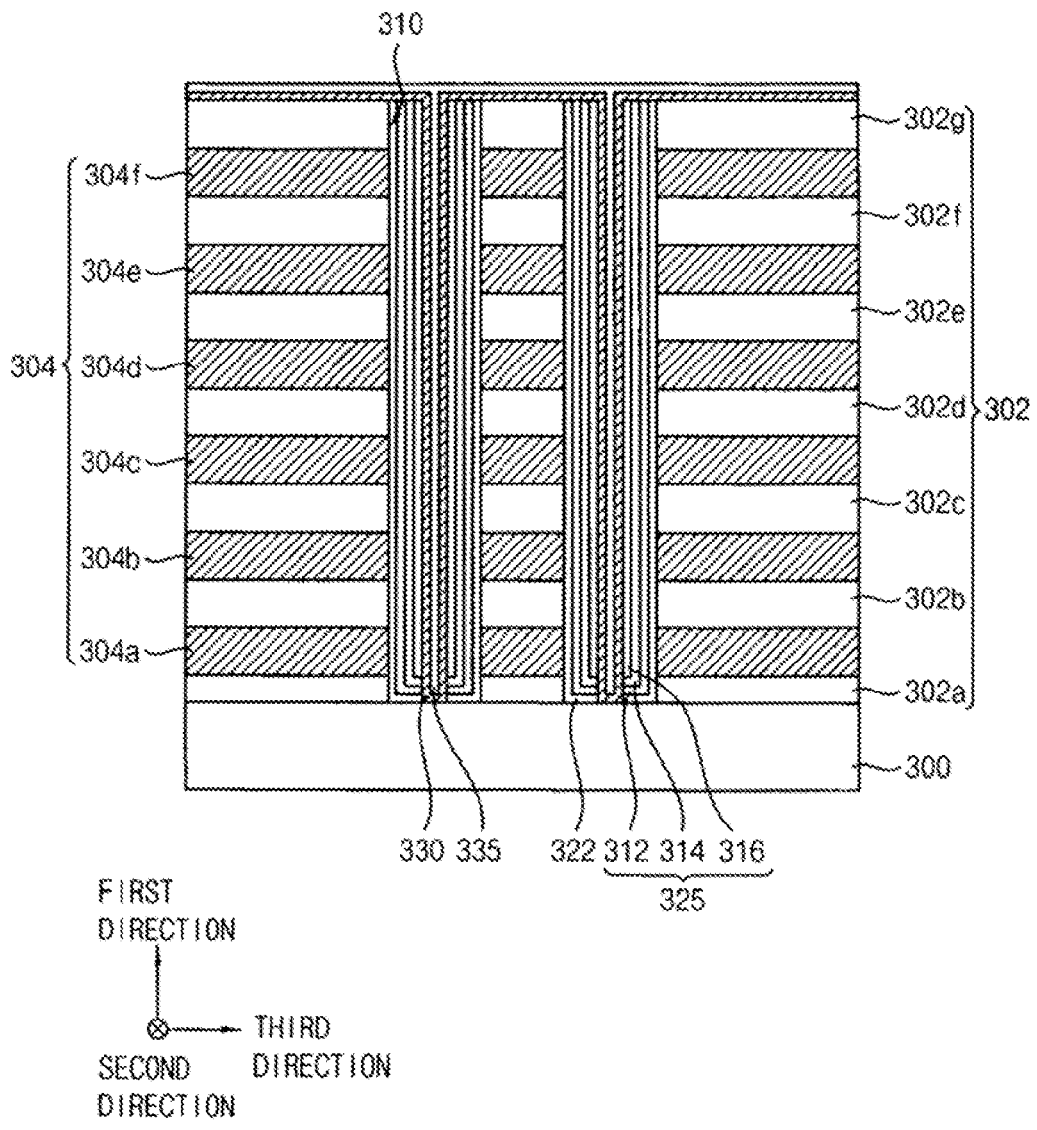

FIG. 29

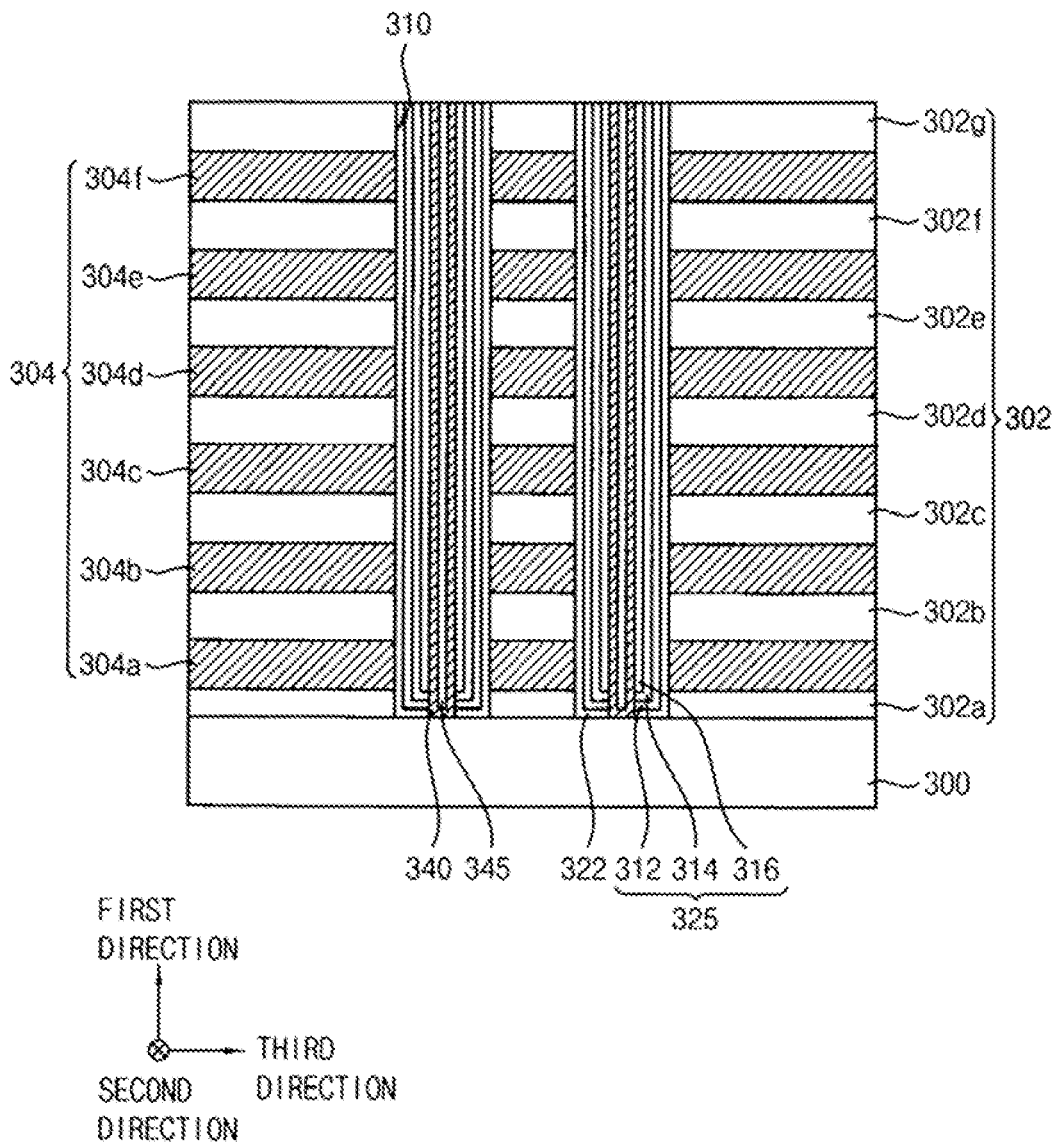

FIG. 30

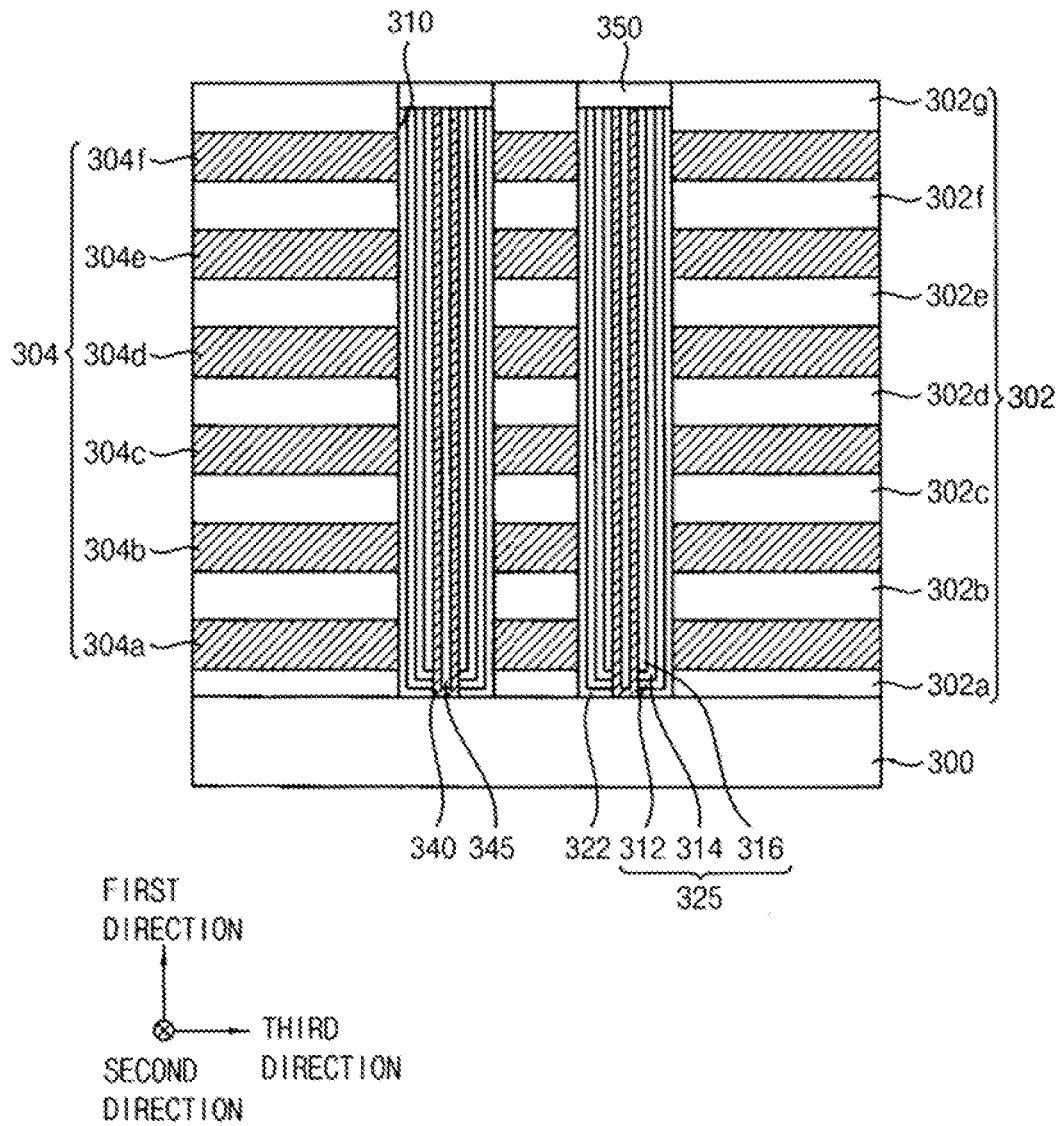

FIG. 31

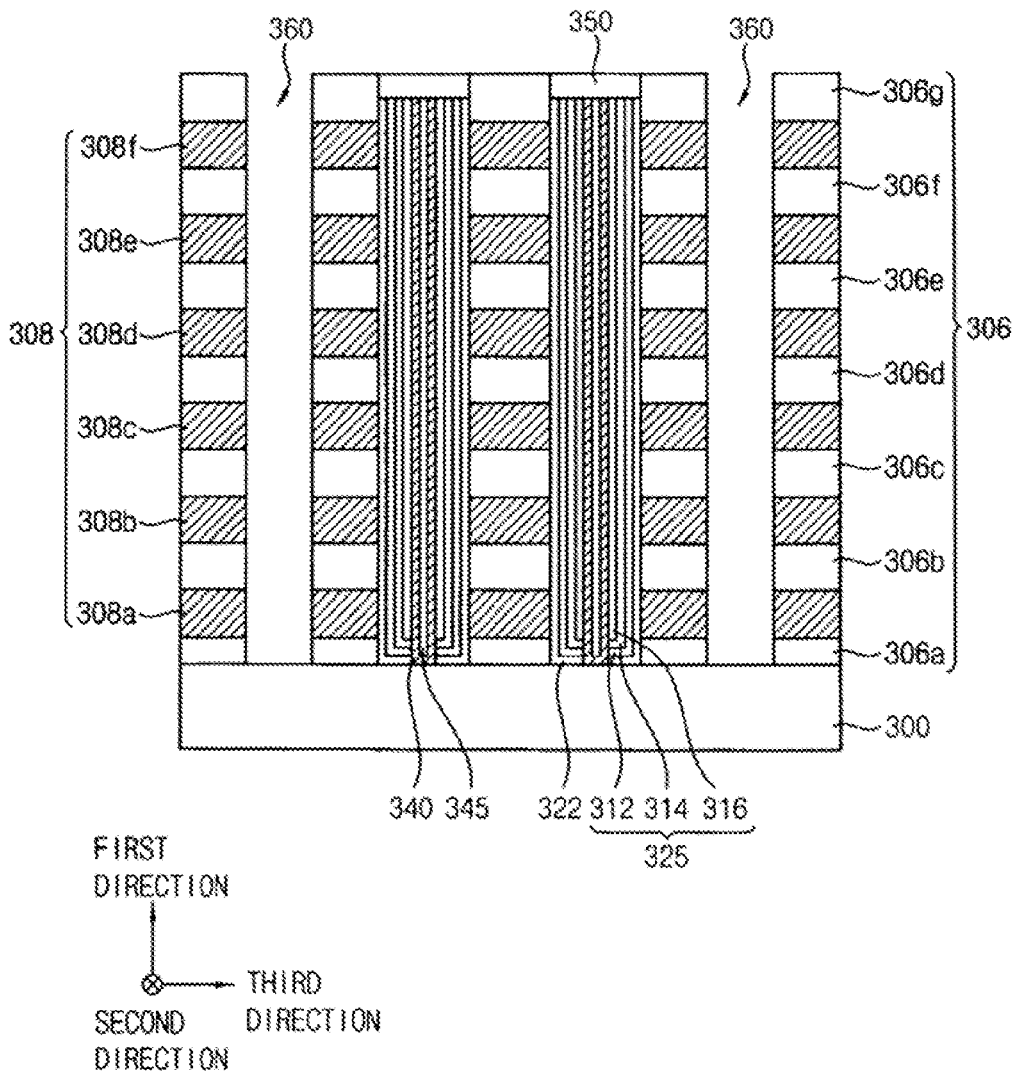

FIG. 32

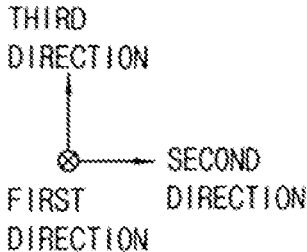
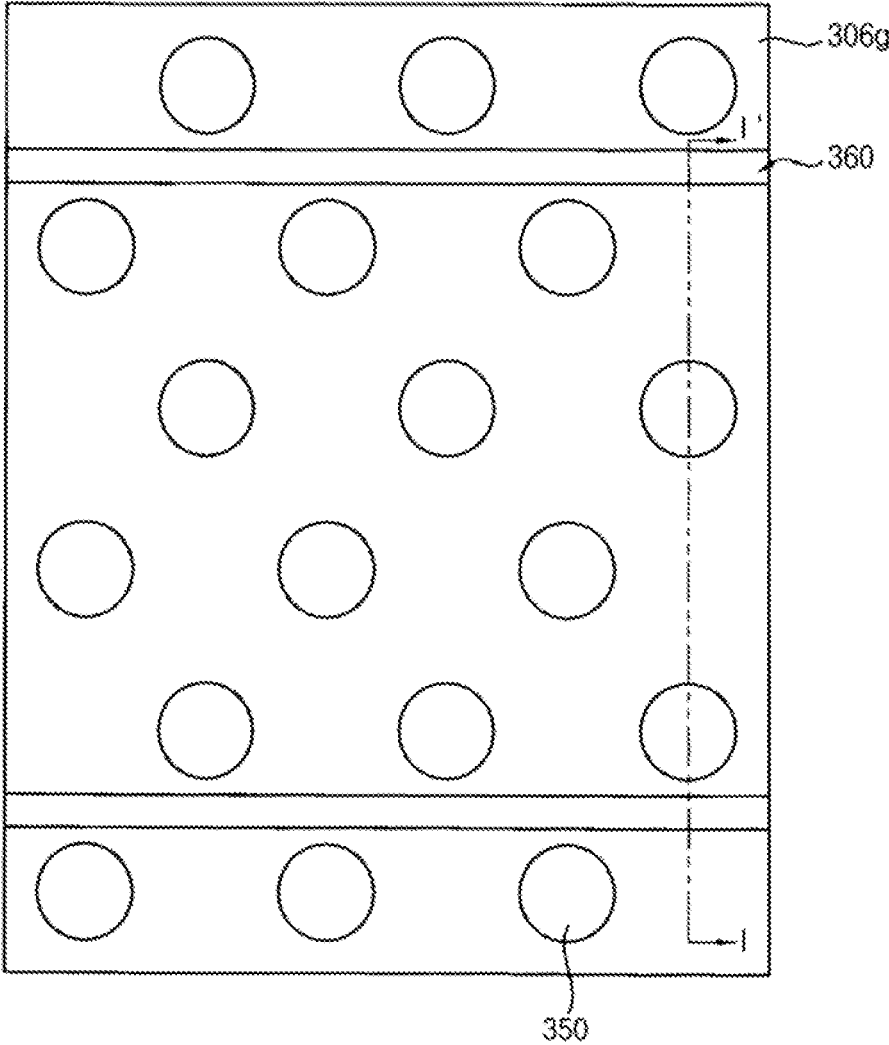

FIG. 33

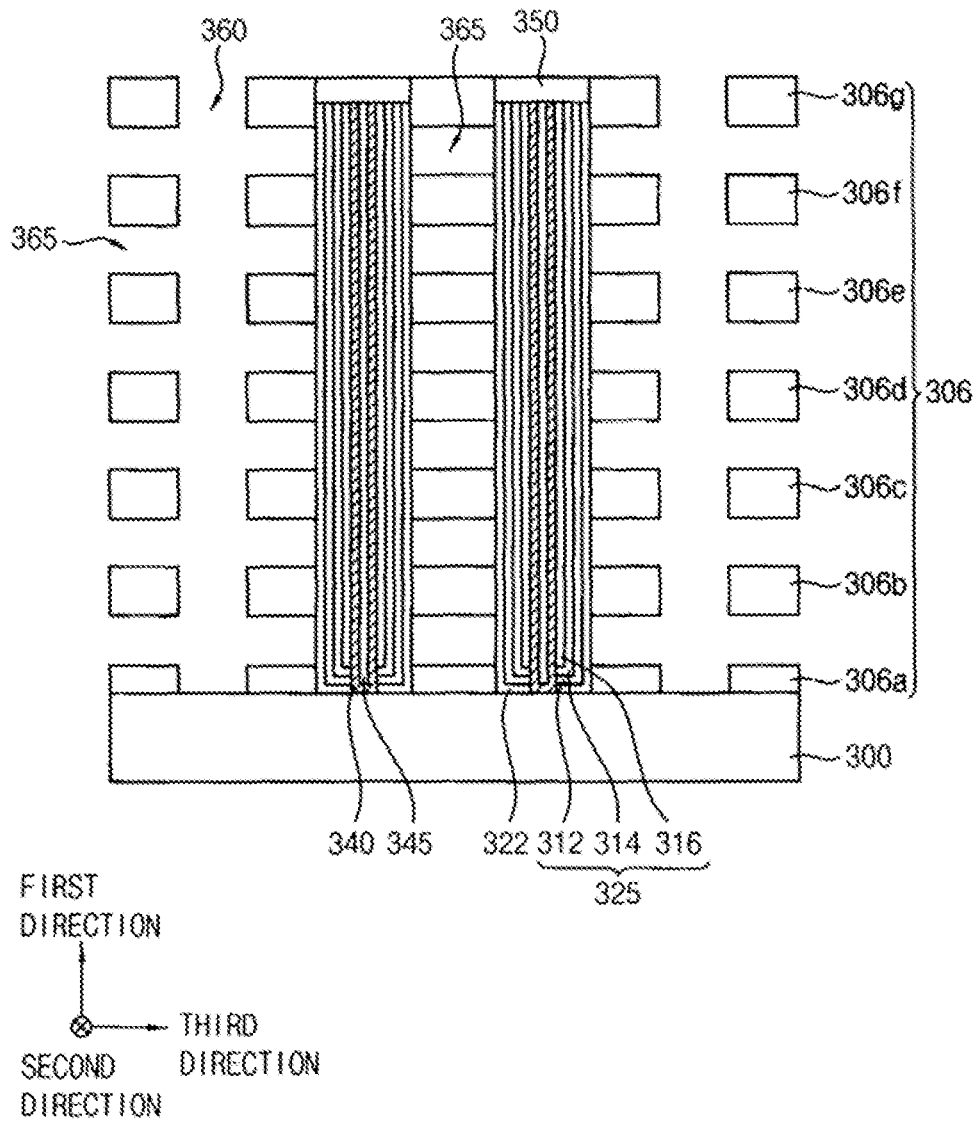

FIG. 34

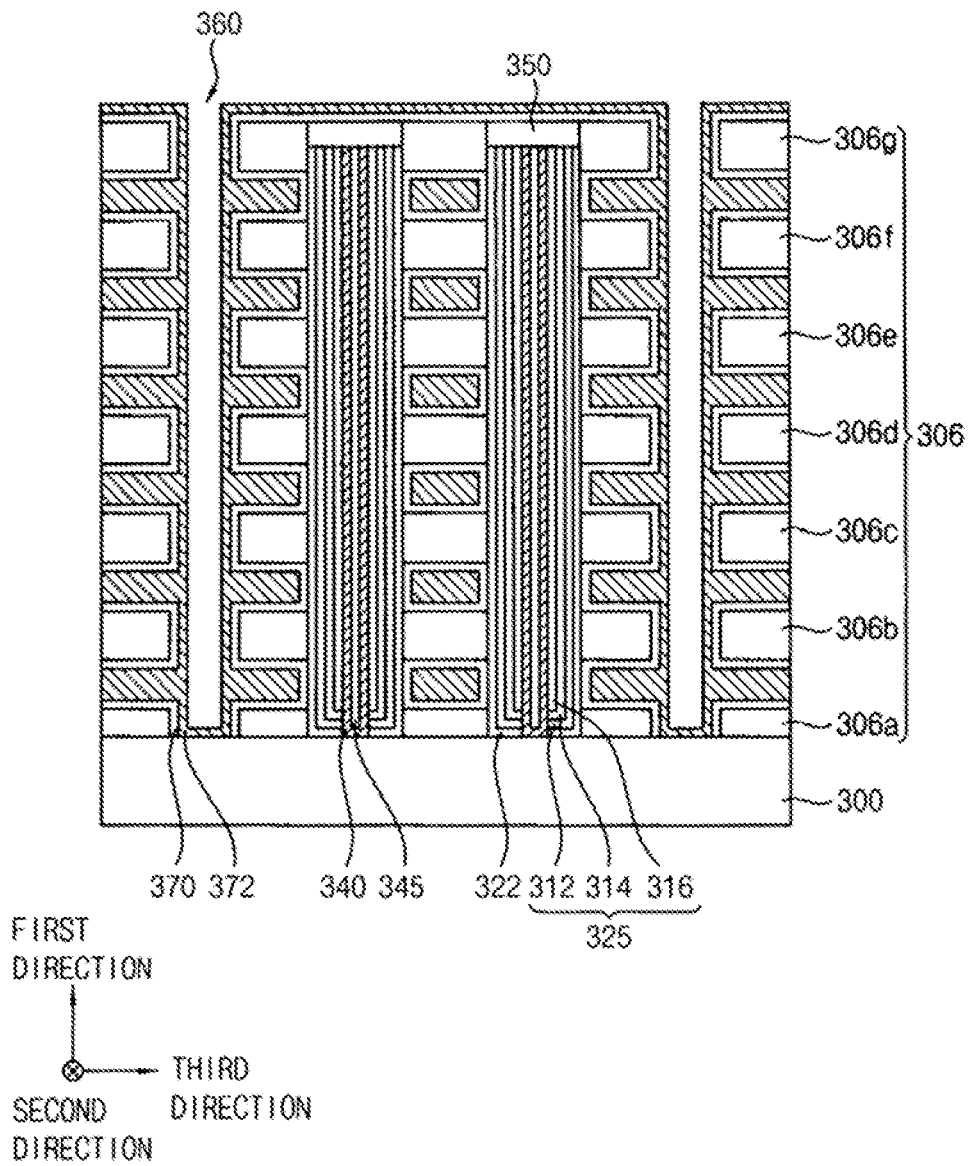

FIG. 35

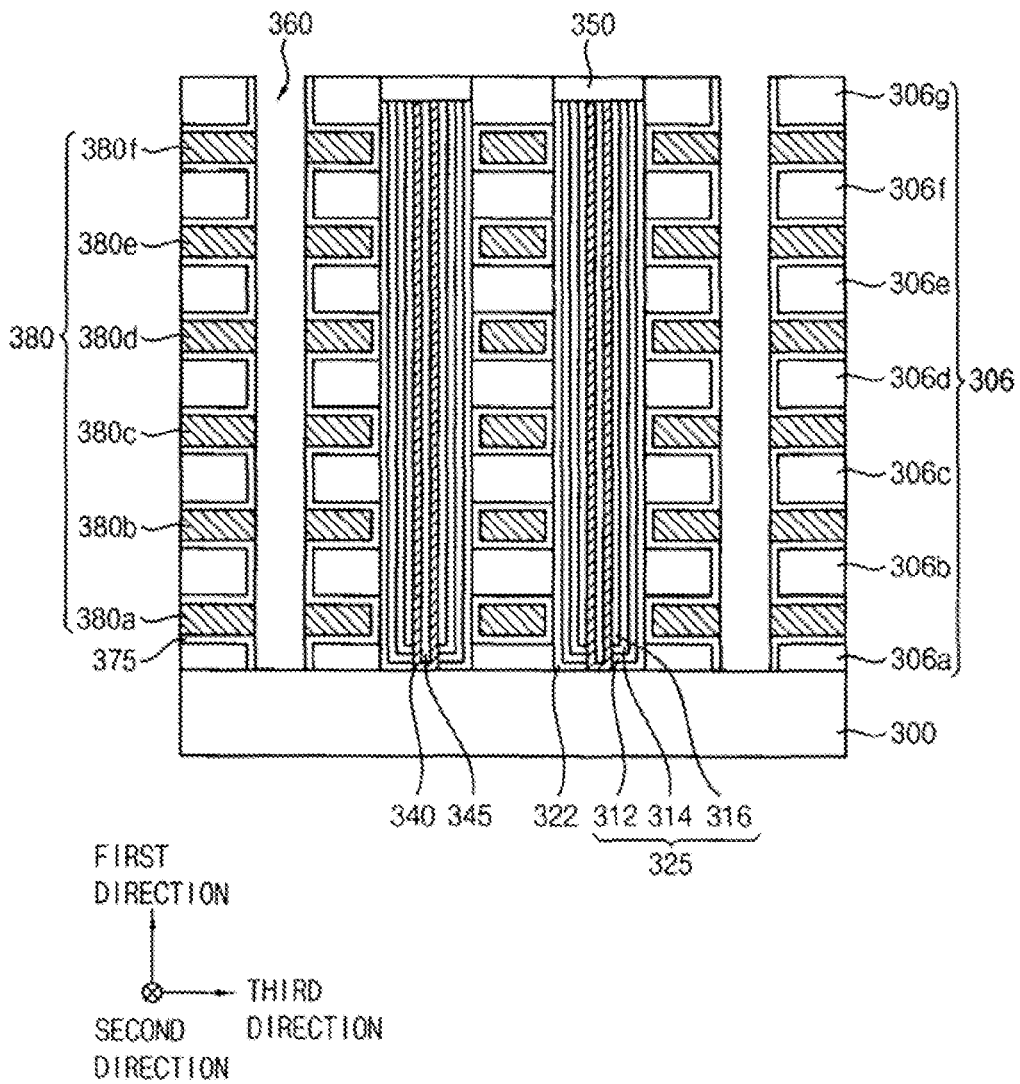

FIG. 36

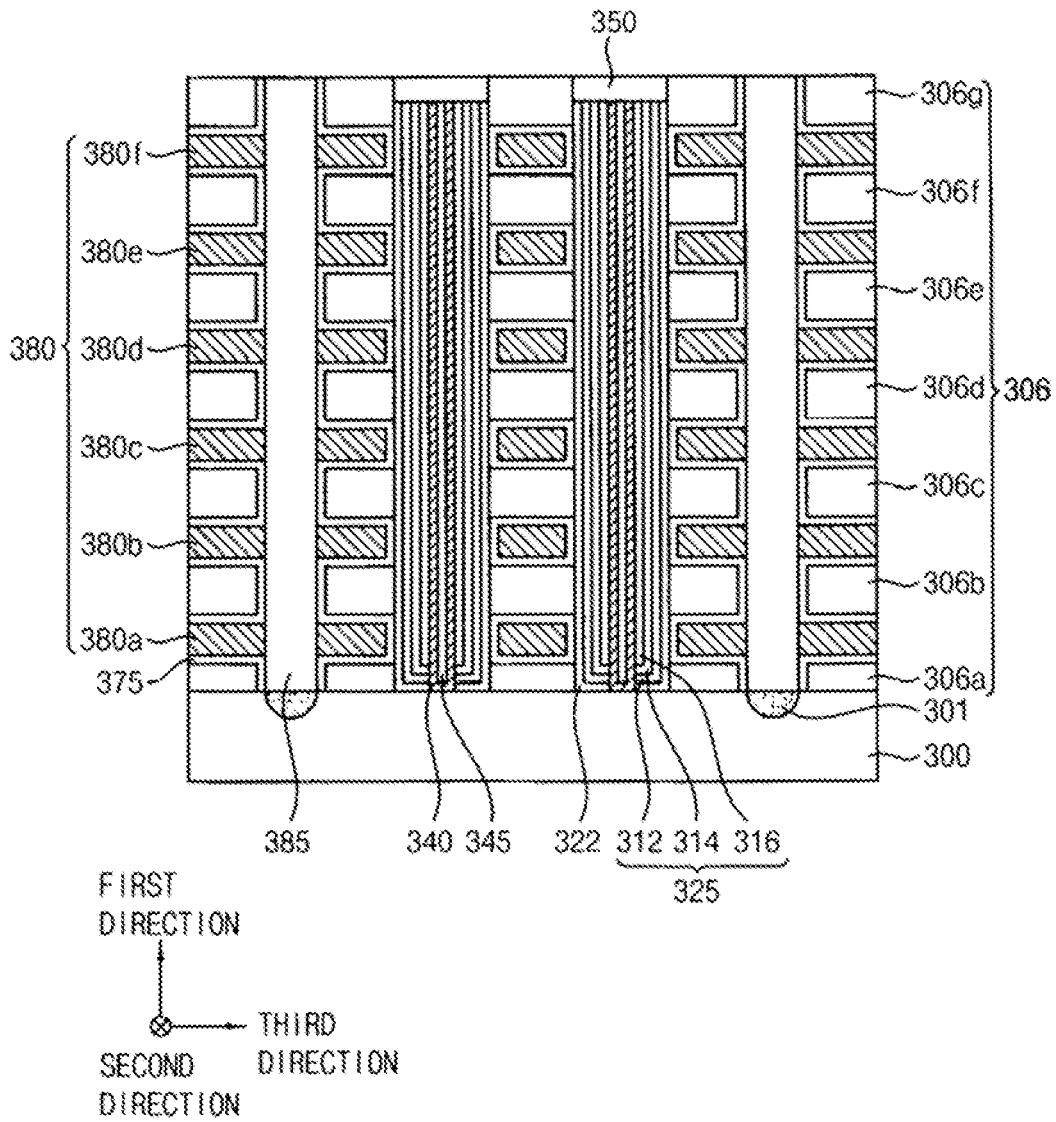

FIG. 37

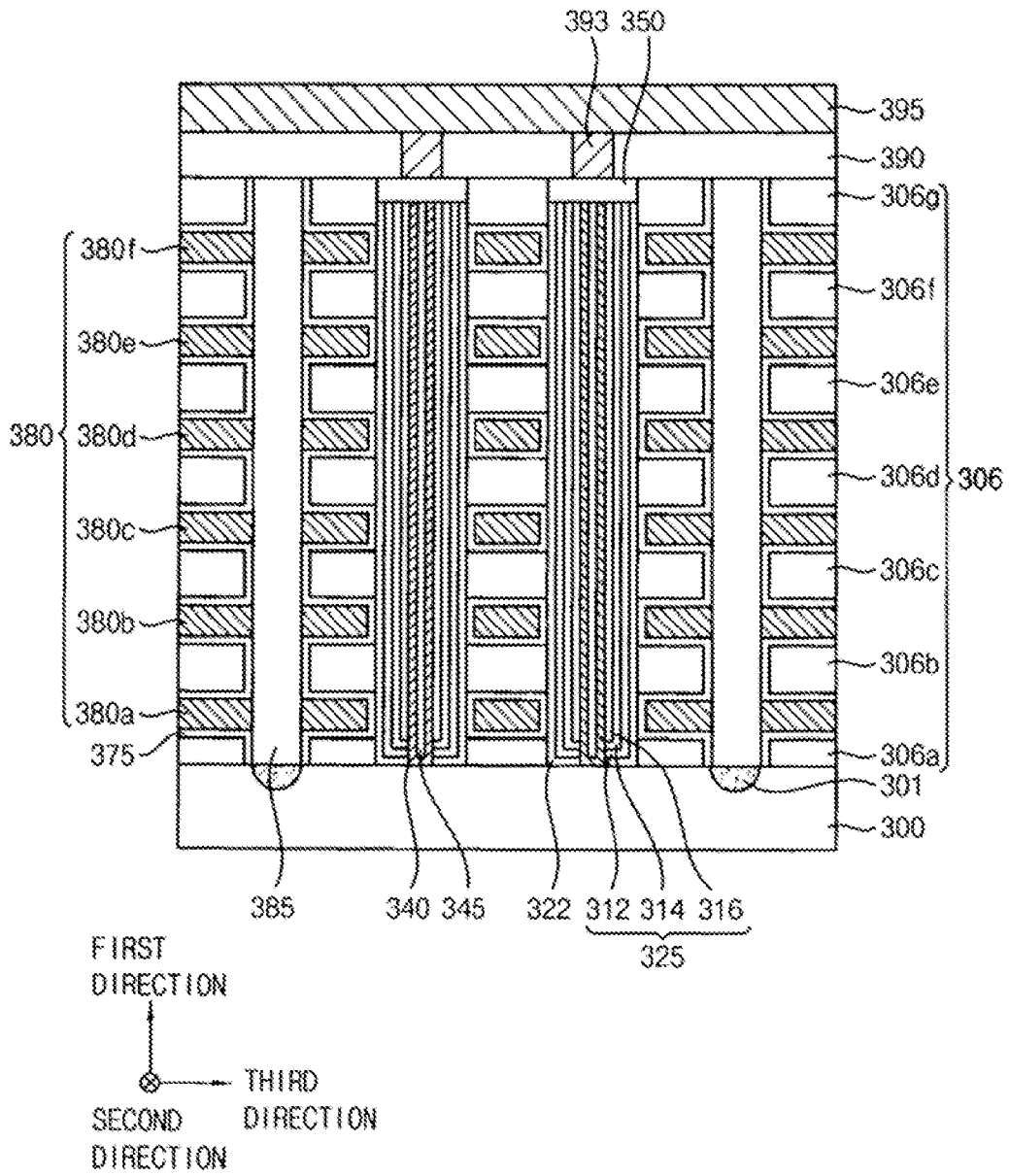

FIG. 38

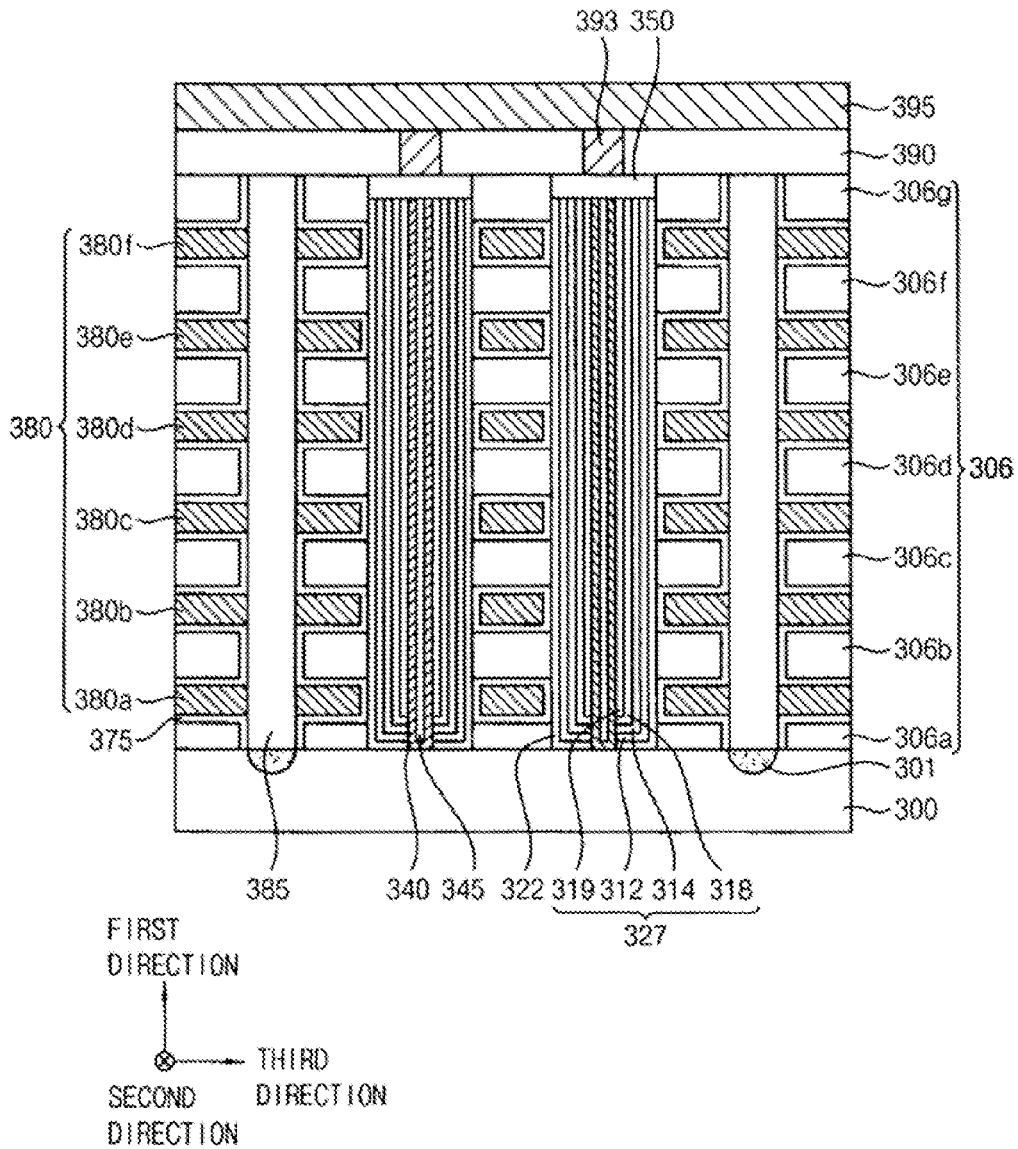

FIG. 39

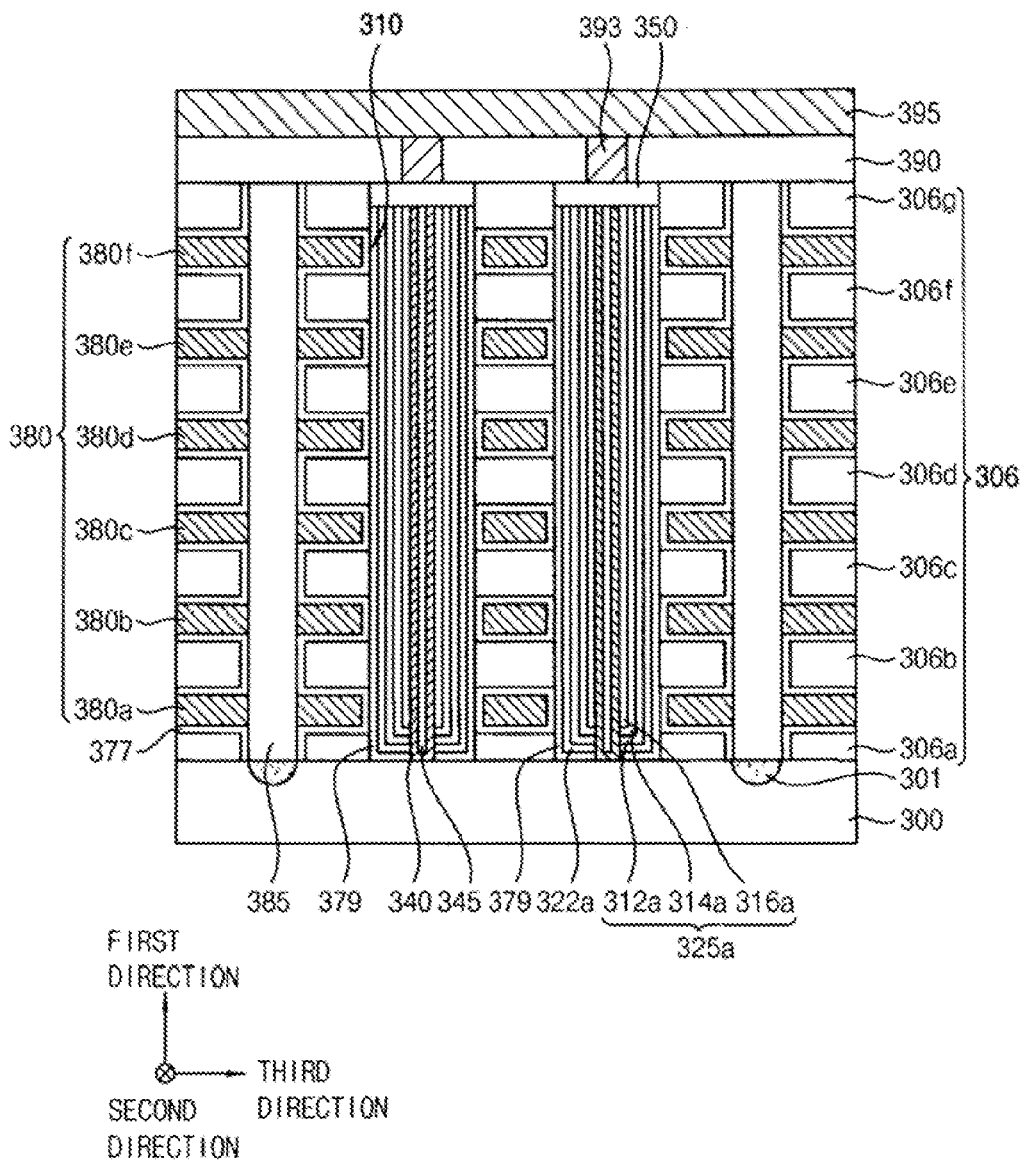

FIG. 40

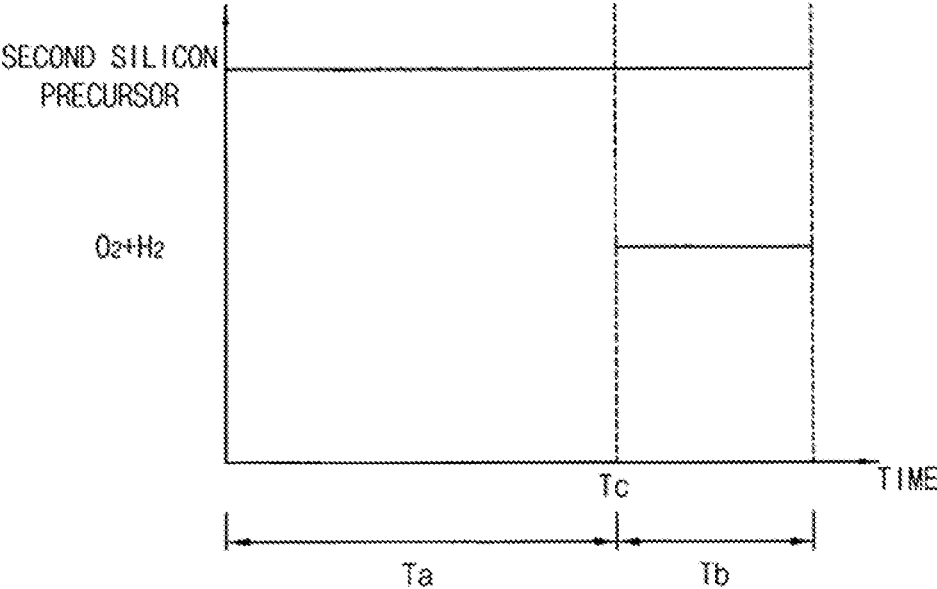

FIG. 41

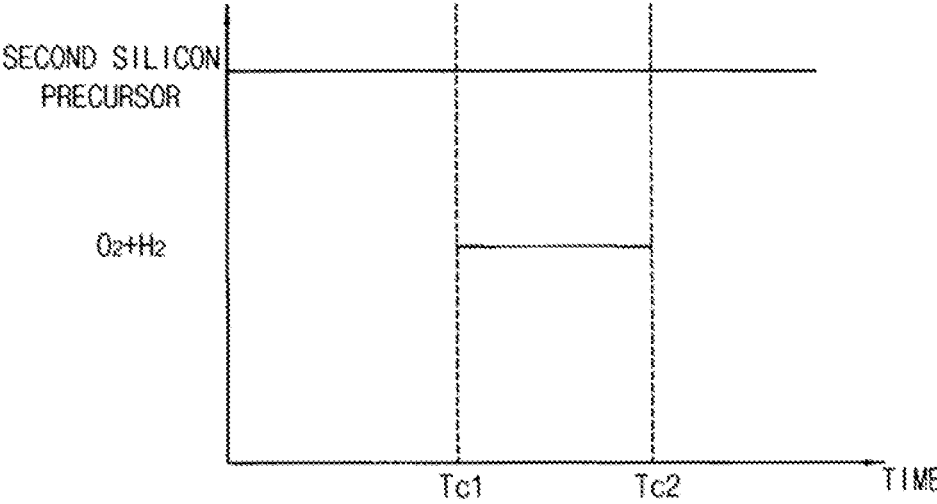

FIG. 42

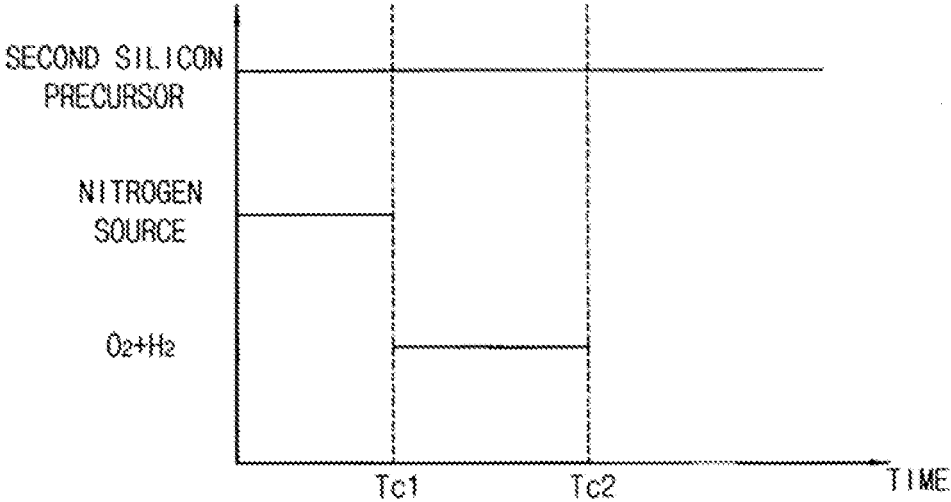
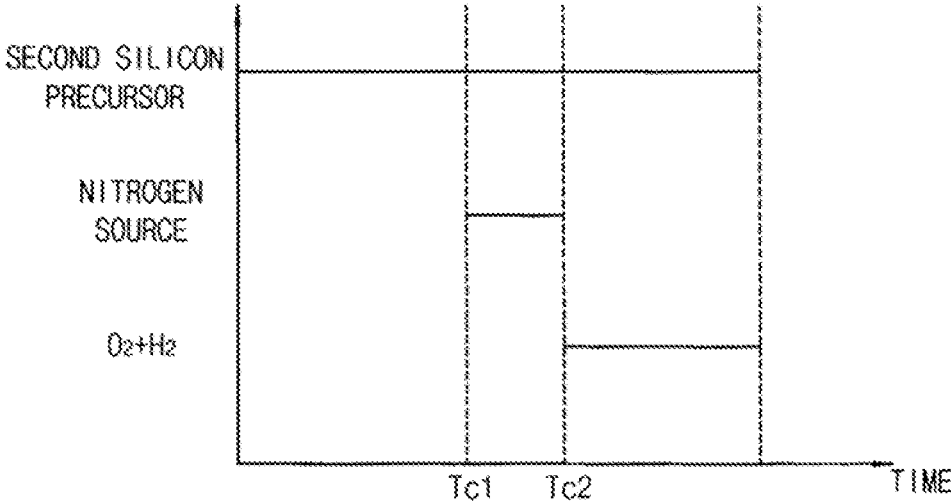

FIG. 43



1

**SEMICONDUCTOR DEVICES AND
METHODS OF MANUFACTURING THE
SAME**

CROSS-REFERENCE TO RELATED
APPLICATION

This application is a divisional of U.S. patent application Ser. No. 14/963,987, filed on Dec. 9, 2015, which claims priority under 35 U.S.C. § 119 to Korean Patent Application No. 10-2014-0177547, filed on Dec. 10, 2014 in the Korean Intellectual Property Office (KIPO), the disclosure of which is incorporated by reference herein in its entirety.

TECHNICAL FIELD

The present inventive concept relates to semiconductor devices and manufacturing the same.

DISCUSSION OF RELATED ART

Non-volatile semiconductor devices may include a floating gate-type flash memory device or a charge trap-type flash memory device. In the flash memory device, a tunnel insulation layer may be interposed between a channel and a gate to control an electron movement. To achieve a reliable operation of the semiconductor device, operational and mechanical stability in the tunnel insulation layer may be needed.

SUMMARY

According to an exemplary embodiment of the present inventive concept, a semiconductor device is provided as follows. A tunnel insulation layer is disposed on a substrate. The tunnel insulation layer includes a first silicon oxide layer, a second silicon oxide layer, and a silicon layer interposed between the first silicon oxide layer and the second silicon oxide layer. The silicon layer has a thickness smaller than a thickness of each of the first silicon oxide layer and the second silicon oxide layer. A gate pattern is disposed on the tunnel insulation layer.

According to an exemplary embodiment of the present inventive concept, a semiconductor device is provided as follows. A plurality of insulating interlayers and a plurality of gate lines are disposed on a substrate. Each insulating interlayer and each gate line are alternately and repeatedly stacked on the substrate. A channel hole penetrates through the insulating interlayers and the gate lines. A charge trap layer is disposed on a sidewall of the channel hole. A tunnel insulation layer is disposed on the charge trap layer. The tunnel insulation layer includes a first silicon oxide layer, a second silicon oxide layer, and a silicon layer interposed between the first silicon oxide layer and the second silicon oxide layer. The silicon layer has a thickness smaller than a thickness of each of the first silicon oxide layer and the second silicon oxide layer. A channel is disposed on the tunnel insulation layer and in the channel hole.

According to an exemplary embodiment of the present inventive concept, a method of manufacturing a semiconductor device is provided as follows. A first silicon oxide layer is formed on a substrate. A first silicon precursor and a first hydrogen flow are provided to form a silicon layer on the first silicon oxide layer. A second silicon precursor, an oxygen flow and a second hydrogen flow are provided to

2

form a second silicon oxide layer on the silicon layer. A plurality of gate patterns is formed on the second silicon oxide layer.

According to an exemplary embodiment of the present inventive concept, a method of manufacturing a semiconductor device is provided as follows. A plurality of insulating interlayers and a plurality of sacrificial layers are formed on a substrate to form a mold structure. Each insulating interlayer and each sacrificial layer are alternately and repeatedly stacked on the substrate. A channel hole is formed, penetrating through the mold structure. A charge trap layer is formed on a sidewall of the channel hole. A first silicon oxide layer is formed on the charge trap layer. A first silicon precursor and a first hydrogen flow are provided to form a silicon layer on the first silicon oxide layer. A second silicon precursor, an oxygen flow and a second hydrogen flow are provided to form a second silicon oxide layer on the silicon layer. A channel is formed on the second silicon oxide layer. The channel is disposed in the channel hole. A plurality of gate lines is formed by replacing each sacrificial layer with each gate line.

According to an exemplary embodiment of the present inventive concept, a semiconductor device is provided as follows. A tunneling insulation layer is disposed on a substrate having hole carriers, and the tunneling insulation layer includes a first silicon oxide layer, a second silicon oxide layer, and a silicon layer interposed between the first silicon oxide layer and the second silicon oxide layer. A charge storage layer pattern is disposed on the tunneling insulation layer. A gate electrode is disposed on the charge storage layer pattern. The hole carriers pass through the tunneling insulating layer to the charge storage layer at an erase voltage.

BRIEF DESCRIPTION OF THE DRAWINGS

These and other features of the inventive concept will become more apparent by describing in detail exemplary embodiments thereof with reference to the accompanying drawings of which:

FIGS. 1 and 2 are cross-sectional views of semiconductor devices in accordance with exemplary embodiments of the present inventive concept;

FIGS. 3 and 4 are cross-sectional views of semiconductor devices in accordance with exemplary embodiments of the present inventive concept;

FIGS. 5 to 10 are cross-sectional views of a method of manufacturing a semiconductor device in accordance with exemplary embodiments of the present inventive concept;

FIGS. 11 and 12 are cross-sectional views of a method of manufacturing a semiconductor device in accordance with exemplary embodiments of the present inventive concept;

FIGS. 13 to 18 are cross-sectional views of a method of manufacturing a semiconductor device in accordance with exemplary embodiments of the present inventive concept;

FIGS. 19 and 20 are cross-sectional views of a method of manufacturing a semiconductor device in accordance with exemplary embodiments of the present inventive concept;

FIG. 21 is a cross-sectional view of a semiconductor device in accordance with exemplary embodiments of the present inventive concept;

FIGS. 22 to 37 are cross-sectional views and top plan views of a method of manufacturing a semiconductor device in accordance with exemplary embodiments of the present inventive concept;

FIG. 38 is a cross-sectional view of a semiconductor device in accordance with exemplary embodiments of the present inventive concept;

FIG. 39 is a cross-sectional view of a semiconductor device in accordance with exemplary embodiments of the present inventive concept;

FIGS. 40 and 41 show deposition source gas profiles to form a second silicon oxide layer in accordance with exemplary embodiment of the present inventive concept; and

FIGS. 42 and 43 show deposition source gas profiles to form a silicon oxynitride layer and a second silicon oxide layer in accordance with exemplary embodiment of the present inventive concept.

Although corresponding plan views and/or perspective views of some cross-sectional view(s) may not be shown, the cross-sectional view(s) of device structures illustrated herein provide support for a plurality of device structures that extend along two different directions as would be illustrated in a plan view, and/or in three different directions as would be illustrated in a perspective view. The two different directions may or may not be orthogonal to each other. The three different directions may include a third direction that may be orthogonal to the two different directions. The plurality of device structures may be integrated in a same electronic device. For example, when a device structure (e.g., a memory cell structure or a transistor structure) is illustrated in a cross-sectional view, an electronic device may include a plurality of the device structures (e.g., memory cell structures or transistor structures), as would be illustrated by a plan view of the electronic device. The plurality of device structures may be arranged in an array and/or in a two-dimensional pattern.

DETAILED DESCRIPTION OF EXEMPLARY EMBODIMENTS

Exemplary embodiments of the inventive concept will be described below in detail with reference to the accompanying drawings. However, the inventive concept may be embodied in different forms and should not be construed as limited to the embodiments set forth herein. In the drawings, the thickness of layers and regions may be exaggerated for clarity. It will also be understood that when an element is referred to as being "on" another element or substrate, it may be directly on the other element or substrate, or intervening layers may also be present. It will also be understood that when an element is referred to as being "coupled to" or "connected to" another element, it may be directly coupled to or connected to the other element, or intervening elements may also be present. Like reference numerals may refer to the like elements throughout the specification and drawings.

FIGS. 1 and 2 are cross-sectional views illustrating semiconductor devices in accordance with exemplary embodiments.

Two directions parallel to a top surface of a substrate and crossing each other are defined as a first direction and a second direction. For example, the first direction and the second direction are perpendicular to each other. The definitions of the first and second directions are substantially the same throughout FIGS. 3 to 20.

Referring to FIG. 1, the semiconductor device may include a tunnel insulation layer pattern 125, and a gate pattern 170 disposed on the tunnel insulation layer pattern 125. A gate structure may include the tunnel insulation layer pattern 125 and the gate pattern 170.

In exemplary embodiments, a plurality of the gate structures may be arranged along the first direction. Each of the gate structures may extend in the second direction.

A substrate 100 may include a semiconductor substrate such as a silicon substrate, a germanium substrate, a silicon-germanium substrate, a silicon-on-insulator (SOI) substrate or a germanium-on-insulator (GOI) substrate. In some exemplary embodiments, the substrate 100 may include a group III-V compound such as GaP, GaAs or GaSb. The substrate 100 may further include a well doped with p-type or n-type impurities.

The substrate 100 may be divided into an active region and a field region by a plurality of isolation layers (not illustrated) arranged along the second direction, each of which may extend in the first direction. FIGS. 1 to 20 are cross-sectional views of structures formed on the active region.

The substrate 100 may be also divided into a cell region on which memory cells may be arranged, and a peripheral circuit region. For example, in FIGS. 1 to 4, a central region of the substrate 100 on which four gate structures having a first width are arranged may correspond to the cell region. Both peripheral regions on which the gate structures having a second width are formed may correspond to the peripheral circuit region. The first width may be smaller than the second width.

FIGS. 1 to 4 illustrate that the four gate structures or the four memory cells are arranged on the cell region. The present inventive concept is not limited thereto. For example, $2n$ (n is a positive integer), e.g., 8 or 16 gate structures may be arranged on the cell region.

The tunnel insulation layer pattern 125 may include a first silicon oxide layer pattern 112, a silicon layer pattern 114 and a second silicon oxide layer pattern 116 sequentially stacked on a top surface of the substrate 100. Thus, the tunnel insulation layer pattern 125 may have an oxide-silicon-oxide (OSO) layered structure.

In exemplary embodiments, the silicon layer pattern 114 may have a thickness smaller than each thickness of the first and second silicon oxide layer patterns 112 and 116. In some exemplary embodiments, the second silicon oxide layer pattern 116 may have a thickness greater than that of the first silicon oxide layer pattern 112.

The gate pattern 170 may include a floating gate 135, a dielectric layer pattern 145, a control gate 155 and a gate mask 165. Accordingly, the semiconductor device may be provided as a non-volatile floating gate-type flash memory device.

The floating gate 135 may include doped polysilicon, for example. A charge for determining a logic state may be stored in the floating gate 135.

The dielectric layer pattern 145 may have a single layered structure or a multi-layered structure including an oxide layer and/or a nitride layer. For example, the dielectric layer pattern 145 may have an oxide-nitride-oxide (ONO) layered structure. In some exemplary embodiments, the dielectric layer pattern 145 may include a high dielectric constant (high-k) metal oxide such as hafnium oxide, zirconium oxide, aluminum oxide, tantalum oxide, titanium oxide, or the like.

The control gate 155 may include a conductive material such as doped polysilicon, metal, metal nitride or metal silicide. In some exemplary embodiments, the control gate 155 may include doped polysilicon at a lower portion thereof, and may include the metal silicide at an upper portion thereof. The control gate 155 may serve as a word line of the semiconductor device, for example.

The gate mask **165** may include silicon nitride or silicon oxynitride, for example.

FIGS. **1** to **4** illustrate that the gate structure of the cell region and the gate structure of the peripheral circuit region have the same stack structure. However, in an exemplary embodiment, the control gate **155** and the floating gate **135** included in the gate structure on the peripheral circuit region may be partially in contact with each other, or may be electrically connected to each other.

A gate spacer **175** may be formed on a sidewall of the gate structure. The gate spacer **175** may include silicon nitride, for example.

A first impurity region **103** and a second impurity region **105** may be formed in upper portions of the substrate **100** and be adjacent to the gate structures. For example, the first and second impurity regions **103** and **105** may be formed in upper portions of the substrate **100** and be between the cell region and the peripheral circuit region.

A first insulating interlayer **180** may be formed on the substrate **100** to cover the gate structures. A first plug **185** may penetrate through the first insulating interlayer **180**, and may be in contact with or electrically connected to the first impurity region **103**. In exemplary embodiments, the first plug **185** may serve as a common source line (CSL) or a CSL contact.

A second insulating interlayer **190** may be formed on the first insulating interlayer **180** to cover the first plug **185**. A second plug **193** may penetrate through the second and first insulating interlayers **190** and **180**, and may be in contact with or electrically connected to the second impurity region **105**. In exemplary embodiments, the second plug **193** may serve as a bit line contact.

The first and second insulating interlayers **180** and **190** may include a silicon oxide-based material such as plasma enhanced oxide (PEOX), tetraethyl orthosilicate (TEOS), boro tetraethyl orthosilicate (BTEOS), phosphorous tetraethyl orthosilicate (PTEOS), boro phospho tetraethyl orthosilicate (BPTEOS), boro silicate glass (BSG), phospho silicate glass (PSG), boro phospho silicate glass (BPSG), or the like.

The first and second plugs **185** and **193** may include a conductive material such as a metal, a metal nitride or a metal silicide. The first and second plugs **185** and **193** may be self-aligned with the gate spacer **175**.

For example, a bit line **195** electrically connected to the second plug **193** may be disposed on the second insulating interlayer **190**. The bit line **195** may extend in the second direction. The bit line **195** may include a conductive material such as a metal, a metal nitride or a metal silicide.

FIG. **1** illustrates that the semiconductor device has a floating gate-type structure. The present inventive concept is not limited thereto. For example, the semiconductor device may have a charge trap-type structure. In this case, the floating gate **135**, the dielectric layer pattern **145** and the control gate **155** included in the gate pattern **170** may be replaced with a charge trap layer pattern, a blocking layer pattern and a gate electrode, respectively.

The charge trap layer pattern may include nitride such as silicon nitride. The blocking layer pattern may include silicon oxide, or a high-k metal oxide such as hafnium oxide, titanium oxide, tantalum oxide, zirconium oxide, aluminum oxide, etc. The gate electrode may include a conductive material such as metal, metal nitride or metal silicide.

Hereinafter, detailed descriptions are provided based on implementations that the gate pattern includes the floating gate **135**, the dielectric layer pattern **145** and the control gate **155**.

As described above, the tunnel insulation layer pattern **125** included in a floating gate-type or a charge trap-type memory device may have the OSO layered structure. The tunnel insulation layer pattern **125** may include the silicon layer **112** as an intermediate layer which is interposed between the first silicon oxide layer pattern **112** and a second silicon oxide layer pattern **116**. The silicon layer **112** as the intermediate layer of the tunnel insulation layer pattern **125** may have a small valence band offset at the junction between the silicon layer **112** and the oxide layers **112** and **116** such that an erase voltage required to erase an electron stored in the floating gate or the charge trap layer pattern using a hole injection may be reduced.

In a comparative example, an ONO (oxide-nitride (or oxynitride)-oxide) layered structure may be used as the tunnel insulation layer pattern **125** to decrease an erase voltage. In this case, greater a nitrogen content in the nitride layer (or oxynitride layer), smaller the valence band offset and the erase voltage. However, the nitride layer may have a charge trap property, and thus a charge that may be designated to be stored in the floating gate or the charge trap layer pattern may be lost. Further, such charge trap in the nitride layer may bend the valence band at the junction between the oxide layer and the nitride layer, and thus the erase voltage may be increased.

However, according to exemplary embodiments, the silicon layer having a low charge trap property may be employed as the intermediate layer of the tunnel insulation layer pattern **125** instead of the nitride layer or the oxynitride layer. Thus, the valence band offset may be reduced without causing a charge loss. Therefore, an erase operation may be performed using a small erase voltage in the gate structure.

Additionally, according to exemplary embodiments, the thickness of the silicon layer pattern **114** may be smaller than the each thickness of the first and second silicon oxide layer patterns **112** and **116**. Thus, the thicknesses of the silicon oxide layer patterns **112** and **116** that may be substantially charge trap-free or may have the least charge trap property may be increased within a predetermined thickness of the tunnel insulation layer pattern **125** while the band-gap may be controlled by the thin-layered silicon layer pattern **114**.

Referring to FIG. **2**, a tunnel insulation layer pattern **225** may further include a silicon oxynitride layer pattern in the tunnel insulation layer pattern **125** of FIG. **1**. In exemplary embodiments, the tunnel insulation layer pattern **225** may include a first silicon oxide layer pattern **212**, a silicon oxynitride layer pattern **214**, a silicon layer pattern **216** and a second silicon oxide layer pattern **218** sequentially stacked on the top surface of the substrate **100**.

In this case, a gate spacer **176** may be formed on sidewalls of the gate pattern **170** and the tunnel insulation layer pattern **225** additionally including the silicon oxynitride layer pattern **214**.

In exemplary embodiments, a thickness of the silicon oxynitride layer pattern **214** may be smaller than that of the silicon layer pattern **216**. In some exemplary embodiments, the thickness of the silicon oxynitride layer pattern **214** may be smaller than each thickness of the first silicon oxide layer pattern **212**, the silicon layer pattern **216** and the second silicon oxide layer pattern **218**.

Accordingly, the valence band offset and the erase voltage may be further reduced by an addition of nitrogen ingredients, while minimizing a charge trap possibly caused by the silicon oxynitride layer pattern **214**.

In some exemplary embodiments, a silicon oxynitride layer pattern may be interposed between the second silicon oxide layer pattern **218** and the silicon layer pattern **216**. In

some exemplary embodiments, a silicon oxynitride layer pattern may be interposed between the first silicon oxide layer pattern **212** and the silicon layer pattern **216**, and/or between the second silicon oxide layer pattern **218** and the silicon layer pattern **216**.

FIGS. **3** and **4** are cross-sectional views illustrating semiconductor devices in accordance with exemplary embodiments.

The semiconductor devices of FIGS. **3** and **4** may have elements and/or structures substantially the same as or similar to those of the semiconductor devices of FIGS. **1** and **2** except for a structure of a tunnel insulation layer pattern. Thus, detailed descriptions on the repeated elements and structures are omitted herein.

Referring to FIG. **3**, a tunnel insulation layer pattern **122** may not be completely separated under a plurality of gate patterns **170** disposed on a cell region, and may continuously extend on the cell region.

For example, a portion of the tunnel insulation layer pattern **122** between the gate patterns **170** included in gate structures serving as memory cells may have a thickness smaller than a thickness of a portion of the tunnel insulation layer pattern **122** under the gate pattern **170**.

In some exemplary embodiments, a second silicon layer pattern **116** and a silicon layer pattern **114** may be patterned per each cell as the gate pattern **170** and as shown in FIG. **1**. However, a first silicon oxide layer **111** may be continuous, without being patterned per each cell, under the gate patterns **170** in the cell region. For example, the first silicon oxide layer **111** may be provided commonly for the plurality of the gate patterns **170** in the cell region.

In this case, a gate spacer **177** may be formed on sidewalls of the gate pattern **170**, the second silicon oxide layer pattern **116** and the silicon layer pattern **114**, and may be formed on a top surface of the first silicon oxide layer **111**.

A first plug **185** and a second plug **193** may penetrate through insulating interlayers **180** and **190**, and the first silicon oxide layer **111** to be in contact with or electrically connected to a first impurity region **103** and a second impurity region **105**, respectively.

As described above, the second silicon oxide layer pattern **116** and the silicon layer pattern **114** may be patterned in a similar manner to the gate pattern **170** in the cell region so that an operational property of each cell may be achieved. The first silicon oxide layer **111** may be provided commonly on the cell region so that an etching amount for the formation of the gate structures may be reduced, and an etching damage of the substrate **100** serving as a channel may be prevented.

Referring to FIG. **4** and FIG. **2**, a tunnel insulation layer pattern **222** may further include a silicon oxynitride layer pattern **214**. For example, the silicon oxynitride layer pattern **214** may be interposed between a first silicon oxide layer **211** and a silicon layer pattern **216**.

In some exemplary embodiments, the silicon oxynitride layer pattern **214** may be separated per each cell together with a second silicon oxide layer pattern **218** and the silicon layer pattern **216**. The first silicon oxide layer **211** may be continuous under the gate patterns in the cell region, and may be provided commonly for a plurality of cells in the cell region.

In some exemplary embodiments, the silicon oxynitride layer pattern may be interposed between the second silicon oxide layer pattern **218** and the silicon layer pattern **216**.

A gate spacer **178** may be formed on sidewalls of the gate pattern **170**, the second silicon oxide layer pattern **218**, the

silicon layer pattern **216**, the silicon oxynitride layer pattern **214**, and the first silicon oxide layer **211**.

FIGS. **5** to **10** are cross-sectional views showing a method of manufacturing a semiconductor device in accordance with exemplary embodiments of the present inventive concept. For example, FIGS. **5** to **10** illustrate a method of manufacturing the semiconductor device of FIG. **1**.

Referring to FIG. **5**, a first silicon oxide layer **111**, a silicon layer **113** and a second silicon oxide layer **115** may be sequentially formed on a substrate **100** to form a tunnel insulation layer **120**.

In exemplary embodiments, the first silicon oxide layer **111**, the silicon layer **113** and the second silicon oxide layer **115** may be formed by an in-situ deposition process in the same chamber. In some exemplary embodiments, the first silicon oxide layer **111**, the silicon layer **113** and the second silicon oxide layer **115** may be formed by an atomic layer deposition (ALD) process.

For example, a silicon precursor and an oxygen source may be provided on the substrate **100** in the ALD process to form the first silicon oxide layer **111**.

Subsequently, a first silicon precursor and a first hydrogen flow may be provided on the first silicon oxide layer **111** so that the silicon layer **113** may be grown from the first silicon oxide layer **111**.

In some exemplary embodiments, a chlorosilane-based material may be used as the first silicon precursor. For example, the first silicon precursor may include hexachlorodisilane (HCD: Si_2Cl_6), trichlorosilane (SiCl_3H), trimethylchlorosilane ($\text{Si}(\text{CH}_3)_3\text{Cl}$) or dimethylchlorosilane ($\text{Si}(\text{CH}_3)_2\text{Cl}_2$). These may be used alone or in a combination thereof.

In exemplary embodiments, HCD may be solely used as the first silicon precursor for the formation of the silicon layer **113** having uniform layer properties and uniform thickness.

The first silicon oxide layer **111** may provide an adsorption site to which the first silicon precursor may be fixed. Thus, the first silicon oxide layer **111** may substantially serve as a seed layer for the silicon layer **113**.

For example, a dangling bond formed on the first silicon oxide layer **111** may serve as the adsorption site for the first silicon precursor. Accordingly, when HCD is provided in a process chamber, HCD may be chemically adsorbed on the first silicon oxide layer **111** so that a preliminary silicon layer having an atomic layer-leveled thin layer structure may be formed.

When a temperature in the process chamber may be increased to a range of about 500°C . to about 700°C ., a bond between silicon atoms of HCD may be dissociated. Subsequently, as the first hydrogen flow may be introduced in the process chamber, a Si—Cl bond may be dissociated. Accordingly, the silicon layer **113** having a thin atomic layer structure may be formed.

A growth rate and a thickness of the silicon layer **113** may be controlled by adjusting a flow rate of the first silicon precursor and/or the first hydrogen flow. In exemplary embodiments, the silicon layer **113** may be formed to be thinner than the first silicon oxide layer **111**.

Subsequently, a second silicon precursor, an oxygen flow and a second hydrogen flow may be provided on the silicon layer **113** to form the second silicon oxide layer **115**. For example, the chlorosilane-based material substantially the same as or similar to the first silicon precursor may be used as the second silicon precursor.

In exemplary embodiments, the second silicon oxide layer **115** may be formed in a process condition for minimizing oxidation of the silicon layer **113**.

For example, a supply time of the second silicon precursor may be controlled to be greater than a supply time of the oxygen flow and the second hydrogen flow so that the silicon layer **113** may be prevented from being oxidized. In some exemplary embodiments, the supply time of the second silicon precursor may be at least twice the supply time of the oxygen flow and the second hydrogen flow.

In some exemplary embodiments, the supply time and a flow rate of the second silicon precursor may be controlled so that the second silicon oxide layer **115** may be thicker than each of the silicon layer **113** and the first silicon oxide layer **111**.

The tunnel insulation layer **120** having an OSO-layered structure may be formed on the substrate **100** by performing the above-described processes.

Referring to FIG. **6**, a floating gate layer **130**, a dielectric layer **140**, a control gate layer **150** and a gate mask layer **160** may be sequentially formed on the tunnel insulation layer **120**.

The floating gate layer **130** may be formed of doped polysilicon, for example. The dielectric layer **140** may be formed as a single layered structure including an oxide layer or a nitride layer, or a multi-layered structure such as an ONO-layered structure. The dielectric layer **140** may be formed of a metal oxide having a high dielectric constant (high-k). The control gate layer **150** may be formed of a conductive material such as doped polysilicon, metal, metal nitride, metal silicide, or the like. The gate mask layer **160** may be formed of silicon nitride or silicon oxynitride.

The floating gate layer **130**, the dielectric layer **140**, the control gate layer **150** and the gate mask layer **160** may be formed by at least one of a chemical vapor deposition (CVD) process, a plasma enhanced chemical vapor deposition (PECVD) process, a sputtering process, a physical vapor deposition (PVD) process and an ALD process.

In some exemplary embodiments, a charge trap layer, a blocking layer and a gate electrode layer may be sequentially formed on the tunnel insulation layer **120** instead of the floating gate layer **130**, the dielectric layer **140** and the control gate layer **150**.

The charge trap layer may be formed of silicon nitride. The blocking layer may be formed of silicon oxide, or a high-k metal oxide such as hafnium oxide, zirconium oxide, aluminum oxide, tantalum oxide, titanium oxide, or the like. The gate electrode layer may be formed of doped polysilicon, metal, metal nitride or metal silicide, for example.

Hereinafter, detailed descriptions are provided based on implementations that the floating gate layer **130**, the dielectric layer **140** and the control gate layer **150** are sequentially formed on the tunnel insulation layer **120**.

In some exemplary embodiments, after forming the floating gate layer **130** and before the formation of the dielectric layer **140**, the floating gate layer **130**, the tunnel insulation layer **120** and an upper portion of the substrate **100** may be sequentially etched along the first direction. Accordingly, trenches (not illustrated) extending in the first direction, and spaced apart from each other along the second direction may be formed in the upper portion of the substrate **100**.

Subsequently, isolation layers (not illustrated) filling the trenches may be formed of silicon oxide, for example. The substrate **100** may be divided into active regions and field regions by the isolation layers. The tunnel insulation layer

120 and the floating gate layer **130** may be converted into line patterns extending in the first direction on the active region.

Referring to FIG. **7**, the gate mask layer **160**, the control gate layer **150**, the dielectric layer **140**, the floating gate layer **130** and the tunnel insulation layer **120** may be sequentially and partially etched to form a gate pattern **170** and a tunnel insulation layer pattern **125**.

For example, the gate mask layer **160** may be partially etched by a photolithography process to form a gate mask **165**. The control gate layer **150**, the dielectric layer **140**, the floating gate layer **130** and the tunnel insulation layer **120** may be sequentially and partially etched using the gate mask **165** as an etching mask to form a control gate **155**, a dielectric layer pattern **145**, a floating gate **135** and the tunnel insulation layer pattern **125**.

Accordingly, the gate pattern **170** including the floating gate **135**, the dielectric layer pattern **145**, the control gate **155** and the gate mask **165** sequentially stacked on the tunnel insulation layer pattern **125** may be formed. A gate structure including the tunnel insulation layer pattern **125** and the gate pattern **170** may be formed.

In exemplary embodiments, a plurality of the gate structures may be formed along the first direction. For example, a central portion of the substrate **100** may correspond to a cell region, and the gate structures having a first width may be formed in the cell region. In the cell region, the gate structures may be spaced apart from each other at a first distance. The gate structures on the cell region may serve as memory cells. FIG. **7** illustrates four gate structures in the cell region. The present inventive concept is not limited thereto. For example, the number of the gate structures in the cell region may be greater than or smaller than four.

Peripheral portions of the substrate **100** may correspond to a peripheral region. The gate structures formed in the peripheral circuit region may have a second width. In the peripheral circuit region, a gate structures in the cell region and a gate structure in the peripheral region may have a second distance which is greater than the first distance between the gate structures in the cell region.

In some exemplary embodiments, the floating gate **135** and the control gate **155** included in the gate structure in the peripheral circuit region may be in contact with or electrically connected to each other. In this case, in the step of FIG. **6**, the floating gate layer **130** and the control gate layer **150** may be connected to each other in the peripheral circuit region using a butting process.

The tunnel insulation layer pattern **125** and the floating gate **135** may each have an island shape on the active region of the substrate **100**. The dielectric layer patterns **145**, the control gates **155** and the gate mask **165** may extend in the second direction, and may be spaced apart from each other along the first direction.

Referring to FIG. **8**, a gate spacer **175** may be formed on sidewalls of the gate structures, and an impurity region may be formed in an upper portion of the substrate **100**.

For example, a spacer layer covering the gate structures may be formed using silicon nitride, and the spacer layer may be anisotropically etched to form the gate spacer **175**.

In some exemplary embodiments, the upper portion of the substrate **100** may be exposed between the gate spacers **175** in the cell region and the peripheral circuit region, because the distance between the gate structures on the cell region and the peripheral circuit region may be relatively large. An ion-implantation process may be performed on the exposed upper portion of the substrate **100** to form a first impurity region **103** and a second impurity region **105**. The first and

11

second impurity regions **103** and **105** may each have a linear shape extending in the second direction or an island shape formed in the upper portion of the substrate **100**.

Referring to FIG. **9**, a first insulating interlayer **180** covering the gate spacer and the gate structures may be formed on the substrate **100**. The first insulating interlayer **180** may be formed of PEOX-based, TEOS-based or silicate glass-based silicon oxide by a CVD process, for example.

A first plug **185** in contact with or electrically connected to the first impurity region **103** may be formed through the first insulating interlayer **180**. For example, the first insulating interlayer **180** may be partially removed to form a first contact hole through which the first impurity region **103** may be exposed. A first conductive layer filling the first contact hole may be formed on the first insulating interlayer **180**, and an upper portion of the first conductive layer may be planarized by a chemical mechanical polish (CMP) process to form the first plug **185**. The first plug **185** may serve as a CSL or a CSL contact of the semiconductor device.

Referring to FIG. **10**, a second insulating interlayer **190** covering the first plug **185** may be formed on the first insulating interlayer **180**. A second contact hole may be formed through the second and first insulating interlayers **190** and **180** to expose the second impurity region **105**. A second conductive layer filling the second contact hole may be formed on the second insulating interlayer **190**, and an upper portion of the second conductive layer may be planarized by a CMP process to form a second plug **193**.

A third conductive layer may be formed on the second insulating interlayer **190** and the second plug **193**, and may be patterned to form a bit line **195**. For example, the bit line **195** may extend in the first direction. The second plug **193** may be electrically connected to the bit line **195** to serve as a bit line contact.

The second insulating interlayer **190** may be formed of silicon oxide which may be substantially the same as or similar to that of the first insulating interlayer **180**. The first to third conductive layers may be formed of metal, metal nitride or metal silicide by a sputtering process or an ALD process. The first and second contact holes may be self-aligned with the gate spacer **175**.

FIGS. **11** and **12** are cross-sectional views of a method of manufacturing a semiconductor device in accordance with some exemplary embodiments of the present inventive concept.

For example, FIGS. **11** and **12** are cross-sectional views of a method of manufacturing the semiconductor device of FIG. **2**. Detailed descriptions on processes and/or materials which are substantially the same as or similar to those described with reference to FIGS. **5** to **10** are omitted herein.

Referring to FIG. **11**, a tunnel insulation layer **220** including a first silicon oxide layer **211**, a silicon oxynitride layer **213**, a silicon layer **215** and a second silicon oxide layer **217** sequentially stacked on a substrate **100** may be formed.

The first silicon oxide layer **211**, the silicon layer **215** and the second silicon oxide layer **217** may be formed using processes and materials which are substantially the same as or similar to those described with reference to FIG. **5**.

In some exemplary embodiments, a nitrogen containing flow may be introduced for a predetermined time before providing a first hydrogen flow for the formation of the silicon layer **215**. In some exemplary embodiments, the nitrogen containing flow may include a mixture of ammonia (NH_3) and nitrous oxide (N_2O). In this case, a first silicon precursor adsorbed on the first silicon oxide layer **211** may be oxy-nitridated to form the silicon oxynitride layer **213**. Subsequently, the first silicon precursor may be successively

12

provided, and the first hydrogen flow may be provided to form the silicon layer **215** on the silicon oxynitride layer **213**.

In exemplary embodiments, the silicon oxynitride layer **213** may be formed to be thinner than the silicon layer **215** so that a charge trap of the silicon oxynitride layer **213** may be avoided. For example, a supply time or a flow rate of the nitrogen containing flow may be smaller than that of the first hydrogen flow to control a thickness of the silicon oxynitride layer **213**.

As described above, a second silicon precursor, an oxygen flow and a second hydrogen flow may be provided on the silicon layer **215** to form the second silicon oxide layer **217**.

In some exemplary embodiments, a silicon oxynitride layer may be formed between the second silicon oxide layer **217** and the silicon layer **215**. In this case, the nitrogen containing flow may be introduced to form the silicon oxynitride layer for a predetermined time before providing the oxygen flow and the second hydrogen flow.

Referring to FIG. **12**, processes substantially the same as or similar to those illustrated with reference to FIGS. **6** to **7** may be performed.

For example, a floating gate layer, a dielectric layer, a control gate layer and a gate mask layer may be sequentially formed on the tunnel insulation layer **220**. The gate mask layer, the control gate layer, the dielectric layer, the floating gate layer and the tunnel insulation layer **220** may be sequentially etched to form a gate structure including a gate pattern **170** and a tunnel insulation layer pattern **225**.

The tunnel insulation layer pattern **225** may include a first silicon oxide layer pattern **212**, a silicon oxynitride layer pattern **214**, a silicon layer pattern **216** and a second silicon oxide layer pattern **218** sequentially stacked on the substrate **100**. The gate pattern **170** may include a floating gate **135**, a dielectric layer pattern **145**, a control gate **155** and a gate mask **165** sequentially stacked on the tunnel insulation layer pattern **225**.

Processes substantially the same as or similar to those described with reference to FIGS. **8** to **10** may be further performed to obtain the semiconductor device of FIG. **2**.

FIGS. **13** to **18** are cross-sectional views showing a method of manufacturing a semiconductor device in accordance with exemplary embodiments of the present inventive concept.

For example, FIGS. **13** to **18** are cross-sectional views showing a method of manufacturing the semiconductor device of FIG. **3**. Detailed descriptions on processes and/or materials which are substantially the same as or similar to those described with reference to FIGS. **5** to **10** are omitted herein.

Referring to FIG. **13**, processes substantially the same as or similar to those described with reference to FIGS. **5** and **6** may be performed. In exemplary embodiments, a first silicon oxide layer **111**, a silicon layer **113** and a second silicon oxide layer **115** may be sequentially formed on a substrate **100** to form a tunnel insulation layer **120**. A floating gate layer **130**, a dielectric layer **140**, a control gate layer **150** and a gate mask layer **160** may be sequentially formed on the tunnel insulation layer **120**.

Referring to FIG. **14**, the gate mask layer **160** may be partially etched to form a gate mask **165**, and the control gate layer **150**, the dielectric layer **140** and the floating gate layer **130** may be sequentially and partially etched using the gate mask **165** as an etching mask. Accordingly, a gate pattern **170** including a floating gate **135**, a dielectric layer pattern **145**, a control gate **155** and a gate mask **165** sequentially stacked on the tunnel insulation layer **120** may be formed.

13

Referring to FIG. 15, a portion of the tunnel insulation layer 120 exposed between the gate patterns 170 neighboring in the first direction may be partially etched to form a tunnel insulation layer pattern 122.

In exemplary embodiments, the tunnel insulation layer 120 may be partially etch, while the tunnel insulation layer 120 of FIG. 7 may be completely etched between the neighboring gate patterns 170. Thus, the tunnel insulation layer pattern 122 may continuously extend in the first direction on the substrate 100. A portion of the tunnel insulation layer pattern 122 under the gate pattern 170 may have a thickness greater than that of a portion of the tunnel insulation layer pattern 122 between the neighboring gate patterns 170.

In some exemplary embodiments, the second silicon oxide layer 116 and the silicon layer 114 may be etched between the neighboring gate patterns 170 so that a second silicon oxide layer pattern 116 and a silicon layer pattern 114 substantially the same as those shown in FIG. 7 may be formed. However, the first silicon oxide layer 111 need not be substantially etched, and may be provided commonly for a plurality of the gate patterns 170. For example, the first silicon oxide layer 111 may remain continuous without being patterned.

The first silicon oxide layer 111 need not be completely etched between the neighboring gate patterns 170 so that an etching amount for forming gate structures may be reduced. The gate structures having the tunnel insulation layer pattern 122 and the gate pattern 170 may have an operational property per each memory cell. Further, an etching damage of the substrate 100 serving as a channel may be prevented.

Referring to FIG. 16, a gate spacer 177 may be formed on sidewalls of the gate pattern 170, the second silicon oxide layer pattern 116 and the silicon layer pattern 114. For example, a spacer layer covering the gate patterns 170 may be formed on a top surface of the first silicon oxide layer 111, and the spacer layer may be anisotropically etched to form the gate spacer 177. The gate spacer 177 may partially cover the top surface of the first silicon oxide layer 111 exposed between the gate patterns 170 formed in a cell region and a peripheral circuit region.

Referring to FIG. 17, the first silicon oxide layer 111 may be partially etched using the gate spacer 177 as an etching mask. Accordingly, a top surface of the substrate 100 may be partially exposed between the neighboring gate spacers 177.

Impurities may be implanted through the exposed top surface of the substrate 100 to form first and second impurity regions 103 and 105.

Referring to FIG. 18, processes substantially the same as or similar to those illustrated with reference to FIGS. 9 and 10 may be performed.

In exemplary embodiments, a first insulating interlayer 180 covering the impurity regions 103 and 105, the gate spacer 177 and the gate patterns 170 may be formed. A first plug 185 electrically connected to the first impurity region 103 may be formed through the first insulating interlayer 180.

A second insulating interlayer 190 may be formed on the first insulating interlayer 180 and the first plug 185. A second plug 193 electrically connected to the second impurity region 105 may be formed through the second and first insulating interlayers 190 and 180. A bit line 195 electrically connected to the second plug 193 may be formed on the second insulating interlayer 190.

14

FIGS. 19 and 20 are cross-sectional views showing a method of manufacturing a semiconductor device in accordance with some exemplary embodiments of the present inventive concept.

For example, FIGS. 19 and 20 are cross-sectional views showing a method of manufacturing the semiconductor device of FIG. 4. Detailed descriptions on processes and/or materials which are substantially the same as or similar to those illustrated with reference to FIGS. 5 to 10, FIGS. 11 and 12, or FIGS. 13 to 18 are omitted herein.

Referring to FIG. 19, a process substantially the same as or similar to that illustrated with reference to FIG. 11 may be performed to form a tunnel insulation layer 220 including a first silicon oxide layer 211, a silicon oxynitride layer 213, a silicon layer 215 and a second silicon oxide layer 217 sequentially stacked on a substrate 100.

Subsequently, a process substantially the same as or similar to that described with reference to FIG. 14 may be performed to form gate patterns 170, each of which may include a floating gate 135, a dielectric layer pattern 145, a control gate 155 and a gate mask 165 sequentially stacked on the tunnel insulation layer 220.

Referring to FIG. 20, processes substantially the same as or similar to those described with reference to FIGS. 15 to 17 may be performed.

In exemplary embodiments, portions of the tunnel insulation layer 220 exposed between the gate patterns 170 neighboring in the first direction may be partially etched to form a tunnel insulation layer pattern 222.

In some exemplary embodiments, the second silicon oxide layer 217, the silicon layer 215, the silicon oxynitride layer 213 may be partially removed by the etching process to form a second silicon oxide layer pattern 218, a silicon layer pattern 216 and a silicon oxynitride layer pattern 214 which may be patterned per each gate pattern 170.

The first silicon oxide layer 211 need not be substantially etched to be provided commonly for a plurality of the gate patterns 170.

A gate spacer 178 may be formed on sidewalls of the gate pattern 170, the second silicon oxide layer pattern 218, the silicon layer pattern 216 and the silicon oxynitride layer pattern 214. A portion of the first silicon oxide layer 211 between the neighboring gate spacers 178 may be etched such that a top surface of the substrate 100 may be exposed. Impurities may be implanted through the exposed top surface of the substrate 100 to form first and second impurity regions 103 and 105.

Processes substantially the same as or similar to those described with reference to FIGS. 9 and 10 may be performed to obtain the semiconductor device of FIG. 4.

According to exemplary embodiments as described above, the first silicon oxide layer, the silicon layer and the second silicon oxide layer may be formed successively by an in-situ ALD process, for example. The silicon layer may be formed as a thin layer using the first silicon oxide layer as a seed layer and using a silicon precursor such as HCD. Thus, a valence band gap offset of a band-gap may be controlled without causing a charge trap or a charge loss so that an erase voltage may be decreased. Additionally, the silicon oxynitride layer may be formed between the silicon oxide layer and the silicon layer so that the valence band gap offset of the band-gap may be further decreased.

FIG. 21 is a cross-sectional view showing a semiconductor device in accordance with exemplary embodiments. For example, FIG. 21 shows a vertical memory device including a channel vertically protruding from a substrate.

15

In FIG. 21, a direction substantially vertical to a top surface of the substrate is referred to as a first direction, and two directions substantially parallel to the top surface of the substrate and substantially crossing each other are referred to as a second direction and a third direction. For example, the second direction and the third direction are substantially perpendicular to each other. Additionally, a direction indicated by an arrow and a reverse direction thereof are considered as the same direction. The above mentioned definitions of the directions are the same throughout FIGS. 22 to 39.

Illustrations of dimensions of layers, structures, holes, openings, etc., may be different from those of actual structures, or may be modified for convenience of descriptions.

Referring to FIG. 21, the semiconductor device may include a channel 340 extending from a top surface of a substrate 100 in the first direction, a charge trap layer pattern 322 and a tunnel insulation layer pattern 325 surrounding an outer sidewall of the channel 340, a first filling layer pattern 345 in the channel 340, and insulating interlayer patterns 306 and gate lines 380 surrounding the charge trap layer pattern 322 and extending in the second direction.

The substrate 300 may include a semiconductor material silicon and/or germanium, for example. In an exemplary embodiment, the substrate 300 may serve as a p-type well of the vertical memory device.

The insulating interlayer patterns 306 (e.g., 306a to 306g) and the gate lines 380 (e.g., 380a to 380f) may be stacked alternately and repeatedly along the first direction from the top surface of the substrate 300. The insulating interlayer pattern 306 and the gate line 380 at each level may surround a plurality of channels 340, and may extend in the second direction.

The insulating interlayer pattern 306 may include silicon oxide-based material. The gate lines 380 neighboring in the first direction may be insulated from each other by the insulating interlayer pattern 306.

The gate line 380 may include metal or metal nitride. For example, the gate line 380 may include metal having a low electrical resistance and nitride thereof. In an exemplary embodiment, the gate line 380 may include tungsten, tungsten nitride, titanium, titanium nitride, tantalum, tantalum nitride, or platinum. In some exemplary embodiments, the gate line 380 may have a multi-layered structure including a barrier layer formed of a metal nitride and a metal layer.

For example, a lowermost gate line 380a may serve as a ground selection line (GSL). An uppermost gate line 380f may serve as a string selection lines (SSL). Gate lines 380b to 380e between the GSL and the SSL may serve as word lines.

In this case, the GSL, the word lines, and the SSL may be formed at a single level, 4 levels and a single level, respectively. However, the number of levels at which the GSL, the word line and the SSL are formed are not limited thereto. In some exemplary embodiments, the word lines may be formed using 8 levels or at least 16 levels (e.g., "2xn" levels, n is an integer equal to or more than 8). The stacked number of the gate lines 380 may be determined in consideration of a circuit design and a degree of integration of the vertical memory device.

A channel hole 310 may be formed, penetrating through the insulating interlayer patterns 306 and the gate lines 380. The charge trap layer pattern 322, the tunnel insulation layer pattern 325, the channel 340 and the first filling layer pattern 345 may be sequentially formed from a sidewall of the channel hole 310.

16

The channel 340 may be in contact with the top surface of the substrate 300, and have a cup shape. In an exemplary embodiment, the channel 340 may have a hollow cylindrical shape. The channel 340 may include polysilicon or single crystalline silicon, and at least a portion of the channel 340 may further include p-type impurities such as boron (B).

In exemplary embodiments, a plurality of the channels 340 may be arranged along the second direction to form a channel row. A plurality of the channel rows may be arranged along the third direction. The plurality of channels 340 may be individually separated from each other, and each channel 340 may extend in the first direction from the top surface of the substrate 300.

The first filling layer pattern 345 may fill an inner space of the channel 340, and may include an insulating material such as silicon oxide. The first filling layer pattern 345 may a pillar shape extending in the first direction.

A dielectric layer structure may include the charge trap layer pattern 322 and the tunnel insulation layer pattern 325. The dielectric layer structure may have a straw shape surrounding the outer sidewall of the channel 340.

The charge trap layer pattern 322 may include nitride such as silicon nitride, or high-k metal oxide. The charge trap layer pattern 322 may be formed on the sidewall of the channel 340, and may be also formed partially on the top surface of the substrate 300 exposed through the channel hole 310. In an exemplary embodiment, an end part of the charge trap layer pattern 322 may be in contact with the sidewall of the channel 340.

The tunnel insulation layer pattern 325 may be formed on the charge trap layer pattern 322. The tunnel insulation layer pattern 325 may include a first silicon oxide layer pattern 312, a silicon layer pattern 314 and a second silicon oxide layer pattern 316 sequentially stacked from an inner sidewall of the charge trap layer pattern 322. Accordingly, the tunnel insulation layer pattern 325 may have a substantially OSO-layered structure.

In exemplary embodiments, a thickness of the silicon layer pattern 314 may be smaller than a thickness of the first silicon oxide layer pattern 312 and a thickness of the second silicon oxide layer pattern 316. In some exemplary embodiments, the thickness of the first silicon oxide layer pattern 312 may be greater than the thickness of the second silicon oxide layer pattern 316.

For example, the thickness of the first silicon oxide layer pattern 312 may range from about 20 Å to about 30 Å. The thickness of the second silicon oxide layer pattern 316 may range from about 15 Å to about 25 Å. The thickness of the silicon layer pattern 314 may be less than about 20 Å. For example, the thickness of the silicon layer pattern 314 may range from about 10 Å to about 15 Å.

In some exemplary embodiments, a blocking layer pattern 375 may be formed along surfaces of each of the insulating interlayer patterns 306a to 306g, and an outer sidewall of the charge trap layer pattern 322. Accordingly, the gate line 380 at each level may be partially surrounded by the blocking layer pattern 375. The blocking layer pattern 375 may include silicon oxide or a high-k metal oxide, for example.

As described above, each channel hole 310 may be filled with the charge trap layer pattern 322, the tunnel insulation layer pattern 325, the channel 340 and the first filling layer pattern 345. In some exemplary embodiments, a pad 350 capping an upper portion of the channel hole 310 may be formed on the charge trap layer pattern 322, the tunnel insulation layer pattern 325, the channel 340 and the first filling layer pattern 345.

In some exemplary embodiments, a semiconductor pattern (not illustrated) filling a lower portion of the channel hole may be further formed on the substrate **300**. In this case, the charge trap layer pattern **322** and the channel **340** may be in contact with the semiconductor pattern. For example, the lowermost gate line **380a** serving as the GSL may surround a lateral portion of the semiconductor pattern. The semiconductor pattern may include single crystalline silicon or polysilicon, for example.

The second filling layer pattern **385** may extend in the second direction, and may have a fence shape intersecting the gate lines **380** and the insulating interlayer patterns **306** in the first direction. A plurality of the second filling layer patterns **385** may be arranged in the third direction. The predetermined number of the channel rows, and the gate lines **380** surrounding the channel rows may be included between the neighboring second filling layer patterns **385** to form a gate line structure. In some exemplary embodiments, four of the channel rows may be included in one gate line structure. The present inventive concept is not limited thereto, and the gate line structure may include two or more channel rows.

An impurity region **301** may be formed in an upper portion of the substrate **300** under the second filling layer pattern **385**. For example, the impurity region **301** may extend in the second direction, and may serve as a CSL of the vertical memory device.

An upper insulation layer **390** may be formed on an uppermost insulating interlayer pattern **306g**, the pad **350** and the second filling layer pattern **385**. The upper insulation layer **390** and the second filling layer pattern **385** may include an insulating material such as silicon oxide.

A bit line contact **393** may penetrate through the upper insulation layer **390**, and may be in contact with or electrically connected to the pad **350**. A bit line **395** may be disposed on the upper insulation layer **390** to be electrically connected to a plurality of bit line contacts **393**. The bit line **395** may extend in, e.g., the third direction.

According to exemplary embodiments as described above, a tunnel insulation layer included in a charge trap-type vertical memory device may include an OSO-layered structure. A silicon layer may be interposed between oxide layers so that a valence band offset between the silicon layer and the oxide layer may be decreased to reduce an erase voltage while minimizing a charge loss or a charge trap in the tunnel insulation layer. Thus, an erase voltage required for an erase operation in a cell string formed along one channel **340** may be reduced. Therefore, operational and structural reliability of the vertical memory device in which a plurality of memory cells are 3-dimensionally stacked may increase.

FIGS. **22** to **37** are cross-sectional views and top plan views of a method of manufacturing a semiconductor device in accordance with exemplary embodiments of the present inventive concept. For example, FIGS. **22** to **37** illustrate a method of manufacturing the vertical memory device of FIG. **21**.

FIGS. **24** and **32** are top plan views showing the method. FIGS. **22**, **23**, **25** to **31**, and **33** to **37** are cross-sectional views taken along line I-I' indicated in FIGS. **24** and **32**.

Referring to FIG. **22**, insulating interlayers **302** (e.g., **302a** to **302g**) and sacrificial layers **304** (e.g., **304a** to **304f**) may be alternately and repeatedly formed on a substrate **300** to form a mold structure.

In exemplary embodiments, the insulating interlayer **302** may be formed using an oxide-based material, e.g., silicon dioxide, silicon carboxide and/or silicon fluorooxide. The

sacrificial layer **304** may be formed using a material that may have etching selectivity with respect to the insulating interlayer **302** and may be removed by a wet etching process. For example, the sacrificial layer **304** may be formed using a nitride-based material, e.g., silicon nitride and/or silicon boronitride.

The insulating interlayer **302** and the sacrificial layer **304** may be formed by a CVD process, a PECVD process, a spin coating process, etc. A lowermost insulating interlayer **302a** may be formed by a thermal oxidation process on the top surface of the substrate **300**. In this case, the lowermost insulating interlayer **302a** may be thinner than other insulating interlayers **302b** through **302g**.

The sacrificial layers **304** may be removed in a subsequent process to provide spaces for a GSL, a word line and an SSL. Thus, the number of the insulating interlayers **302** and the sacrificial layers **304** may be adjusted in consideration of the number of the GSL, the word line and the SSL. For example, as illustrated with reference to FIG. **21**, each of the GSL and the SSL may be formed at a single level, and the word line may be formed at 4 levels. Accordingly, the sacrificial layers **304** may be formed at 6 levels, and the insulating interlayers **302** may be formed at 7 levels as illustrated in FIG. **22**. However, the numbers of the GSL, the SSL and the word line are not limited to the examples provided herein, and may be adjusted in consideration of a degree of integration and a circuit design of the semiconductor device.

Referring to FIGS. **23** and **24**, a plurality of channel holes **310** may be formed through the mold structure.

In exemplary embodiments, a hard mask (not illustrated) may be formed on an uppermost insulating interlayer **302g**. The insulating interlayers **302** and the sacrificial layers **304** may be partially etched by a dry etching process, for example. The hard mask may be used as an etching mask to form the channel hole **310**. A top surface of the substrate **300** may be partially exposed by the channel hole **310**.

The hard mask may be formed of silicon-based or carbon-based spin-on hardmask (SOH) materials, and/or a photo-resist material. After the formation of the channel hole **310**, the hard mask may be removed by an ashing process and/or strip process.

As illustrated in FIG. **24**, a plurality of the channel holes **310** may be formed in the second direction to form a channel hole row. A plurality of the channel hole rows may be formed in the third direction. The channel holes **310** included in the neighboring channel hole rows may face each other in a zigzag arrangement.

Referring to FIG. **25**, a charge trap layer **311** may be formed conformally on an uppermost insulating interlayer **302g**, and sidewalls and bottoms of the channel holes **310**.

For example, the charge trap layer **311** may be formed of silicon nitride by an ALD process.

Referring to FIG. **26**, a tunnel insulation layer **320** may be formed on the charge trap layer **311**.

In exemplary embodiments, a first silicon oxide layer **313**, a silicon layer **315** and a second silicon oxide layer **317** may be sequentially formed on the charge trap layer **311** to form the tunnel insulation layer **320** having an OSO-layered structure.

The first silicon oxide layer **313**, the silicon layer **315** and the second silicon oxide layer **317** may be formed by a process substantially the same as or similar to that described with reference to FIG. **5**.

In some exemplary embodiments, the first silicon oxide layer **313**, the silicon layer **315** and the second silicon oxide layer **317** may be formed by an in-situ ALD process.

The first silicon oxide layer **313** including silicon oxide and having a thickness ranging from about 20 Å to about 30 Å may be formed on the charge trap layer **311** by an ALD process. A first silicon precursor such as HCD and a first hydrogen flow may be introduced in an ALD process chamber, and the silicon layer **315** may be grown from the first silicon oxide layer **313** that may serve as a seed layer or an adsorption layer. The silicon layer **315** may be formed by a chemisorption mechanism, and the formation of the silicon layer **315** may be self-limiting to have a thickness of a substantially atomic layer. Further, pressures and/or flow rates of the first silicon precursor and the first hydrogen flow may be adjusted so that a growth rate of the silicon layer **315** may be controlled.

In some exemplary embodiments, the silicon layer **315** may have a thickness less than about 20 Å. For example, the silicon layer **315** may have a thickness ranging from about 10 Å to about 15 Å.

A second silicon precursor such as HCD, an oxygen flow and a second hydrogen flow may be introduced on the silicon layer **315** to form the second silicon oxide layer **317**.

The second silicon oxide layer **317** may be formed under a condition where oxidation of the silicon layer **315** may be prevented. For example, a supply time of the second silicon precursor may be controlled to be greater than a supply time of a combination of the oxygen flow and the second hydrogen flow. In some exemplary embodiments, the supply time of the second silicon precursor may be at least twice the supply time of the combination of the oxygen flow and the second hydrogen flow.

For example, the supply time of the second silicon precursor may be at least 20 seconds, and the supply time of the combination of the oxygen flow and the second hydrogen flow may be less than about 10 seconds. Further, a flow rate of the second hydrogen flow may be controlled to be less than about 200 standard cubic centimeters per minute (scm). For example, the flow rate of the second hydrogen flow may range from about 100 scm to about 200 scm for preventing the oxidation of the silicon layer **315**.

In some exemplary embodiments, a thickness of the second silicon oxide layer **317** may be greater than that of the silicon layer **315**, and may be smaller than that of the first silicon oxide layer **313** by controlling the supply time and a flow rate of the second silicon precursor. In exemplary embodiments, the thickness of the second silicon oxide layer **317** may range from about 15 Å to about 25 Å.

Referring to FIG. 27, portions of the charge trap layer **311** and the tunnel insulation layer **320** formed on the bottom of the channel hole **310** may be partially removed by an etch-back process. First portions of the charge-trap layer **311** and the tunnel insulation layer **320** formed on the uppermost insulating interlayer **302g** may be removed by the etch-back process. Second portions of the charge-trap layer **311** and the tunnel insulation layer **320** formed on the substrate **300** may be removed in the etch-back process. The first portions and the second portions may be removed at substantially the same time in the etch-back process.

After the etch-back process, the top surface of the substrate **300** may be exposed through the channel hole **310**, and a dielectric layer structure including a charge trap layer pattern **322** and a tunnel insulation layer pattern **325** may be formed on the sidewall of the channel hole **310**. The dielectric layer structure may have a straw shape partially filling the channel hole **310**.

The tunnel insulation layer pattern **325** may include a first silicon oxide layer pattern **312**, a silicon layer pattern **314**

and a second silicon oxide layer pattern **316** sequentially stacked from the charge trap layer pattern **322** to form an OSO-layered structure.

As described above, the thickness of each layer included in the OSO-layered structure may be controlled in the in-situ ALD process so that an operational property of the semiconductor device may increase. For example, the silicon layer pattern **314** formed as an intermediate layer of the OSO-layered structure may have a silicon layer having the smallest thickness so that a valence band offset of a band-gap may decrease and less charges may be trapped in the silicon layer pattern **314** compared to an intermediate layer which would be formed of a material trapping electrons therein, for example, nitride. The first and second silicon oxide layer patterns **312** and **316** may be substantially charge trap-free and may have thicknesses greater than the silicon layer pattern **314**. Such combination of material and thickness between the silicon layer pattern **314** and the silicon oxide layer patterns **312** and **316** may increase reliability of the semiconductor device.

For example, the first silicon oxide layer pattern **312** may have the greatest thickness in the OSO-layered structure to serve as a charge barrier. For example, discharge or diffusion of an electron stored in the charge trap layer pattern **322** may be blocked by the first silicon oxide layer pattern **312**. The second silicon oxide layer pattern **316** may serve as a barrier for preventing the silicon layer pattern **314** from being damaged by native oxidation, a subsequent thermal process, etc, for example. The thickness of the first silicon oxide layer **312** and/or the second silicon oxide layer pattern **316** may be properly adjusted so that the silicon layer **315** may be prevented from being concurrently oxidized.

Referring to FIG. 28, a channel layer **330** may be formed on the uppermost insulating interlayer **302g**, the charge trap layer pattern **322** and the tunnel insulation layer pattern **325**, and then a first filling layer **335** may be formed on the channel layer **330** to completely fill a remaining portion of the channel hole **310**.

The channel layer **330** may be formed using polysilicon or amorphous silicon which is optionally doped with impurities. In exemplary embodiments, a heat treatment or a laser beam irradiation may be further performed on the channel layer **330**. In this case, the channel layer **330** may include single crystalline silicon. The first filling layer **335** may be formed using an insulating material, e.g., silicon oxide or silicon nitride.

The channel layer **330** and the first filling layer **335** may be formed by a CVD process, a PECVD process, an ALD process, a PVD process, etc.

Referring to FIG. 29, upper portions of the first filling layer **335** and the channel layer **330** may be planarized by, e.g., a CMP process until the uppermost insulating interlayer **302g** is exposed. Accordingly, a channel **340** and a first filling layer pattern **345** filling the channel hole **310** may be formed.

The channel **340** may have a cup shape, for example, and the first filling layer pattern **345** may have a pillar shape accommodated in the channel **340**.

The channel **340** may be formed in each of the channel holes **310** such that a plurality of the channels **340** may be arranged to be physically spaced apart from each other on the substrate **300**. A channel row may be formed along the channel hole row, and thus a plurality of the channel rows may be arranged along the third direction.

In some exemplary embodiments, after the formation of the channel hole **310** as illustrated in FIGS. 23 and 24, a semiconductor pattern may be further formed at a lower

21

portion of the channel hole **310** before forming the charge trap layer **311** as illustrated in FIG. **25**. The semiconductor pattern may be formed by a selective epitaxial growth (SEG) process using the top surface of the substrate **300** as a seed. In this case, the semiconductor pattern may fill the lower portion of the channel hole **310**, and the charge trap layer pattern **322**, the tunnel insulation layer pattern **325** and the channel **340** may be formed on a top surface of the semiconductor pattern.

Referring to FIG. **30**, a pad **350** filling an upper portion of the channel hole **310** may be formed.

For example, upper portions of the charge trap layer pattern **322**, the tunnel insulation layer pattern **325**, the channel **340** and the first filling layer pattern **345** may be partially removed by an etch-back process to form a recess, for example. A pad layer may be formed on the uppermost insulating interlayer **302g** to completely fill the recess. An upper portion of the pad layer may be planarized until a top surface of the uppermost insulating interlayer **302g** is exposed to form the pad **350** from a remaining portion of the pad layer. In exemplary embodiments, the pad layer may be formed using polysilicon optionally doped with n-type impurities. In exemplary embodiments, a preliminary pad layer including amorphous silicon may be formed, and then a crystallization process may be performed thereon to form the pad layer.

Referring to FIGS. **31** and **32**, the insulating interlayers **302** and the sacrificial layers **304** may be partially etched to form openings **360**.

In exemplary embodiments, a hard mask (not illustrated) covering the pads **350** and partially exposing the uppermost insulating interlayer **302g** between some of the channel rows may be formed. The insulating interlayers **302** and the sacrificial layers **304** may be partially etched by a dry etching process using the hard mask as an etching mask to form the opening **360**. The hard mask may be formed using a photoresist material or an SOH material. The hard mask may be removed by an ashing process and/or a strip process after the formation of the opening **360**.

The opening **360** may extend in the second direction, and a plurality of the openings **360** may be formed along the third direction by a predetermined distance. For example, four channel rows may be included between the openings **360** neighboring in the third direction.

After the formation of the opening **360**, the insulating interlayers **302** and the sacrificial layers **304** may be changed into insulating interlayer patterns **306** (e.g., **306a** to **306g**) and sacrificial layer patterns **308** (e.g., **308a** through **308f**). The insulating interlayer pattern **306** and the sacrificial layer pattern **308** at each level may be intersected by the opening **360**, and may extend in the second direction. The top surface of the substrate **300**, and sidewalls of the insulating interlayer patterns **306** and the sacrificial layer patterns **308** may be exposed through the opening **360**.

Referring to FIG. **33**, the sacrificial layer patterns **308**, the sidewalls of which are exposed by the opening **360** may be removed. In exemplary embodiments, the sacrificial layer patterns **308** may be removed by a wet etching process using, e.g., phosphoric acid and/or sulfuric acid that may have etching selectivity for silicon nitride as an etchant solution.

A gap **365** may be formed as a space from which the sacrificial layer pattern **308** is removed. A plurality of the gaps **365** may be formed along the first direction. An outer sidewall of the charge trap layer pattern **322** may be at least partially exposed by the gap **365**.

22

Referring to FIG. **34**, a blocking layer **370** may be formed conformally on surfaces of the insulating interlayer patterns **306**, and top surfaces of the pads **350**. A gate electrode layer **372** filling the gaps **365** and partially filling the opening **360** may be formed on the blocking layer **370**.

The blocking layer **370** may be formed of silicon oxide or a high-k metal oxide. The gate electrode layer **372** may be formed using metal or metal nitride having low electrical resistance and work function. For example, the gate electrode layer **372** may be formed using tungsten, tungsten nitride, titanium, titanium nitride, tantalum, tantalum nitride, platinum, etc. In exemplary embodiments, the gate electrode layer **372** may be formed as a multi-layered structure including a barrier layer formed of a metal nitride and a metal layer. The blocking layer **370** and the gate electrode layer **372** may be formed by a CVD process, a PECVD process, an ALD process, a PVD process, a sputtering process, etc.

Referring to FIG. **35**, the blocking layer **370** and the gate electrode layer **372** may be partially etched to form a blocking layer pattern **375** and a gate line **380**.

In exemplary embodiments, upper portions of the blocking layer **370** and the gate electrode layer **372** may be planarized by a CMP process until an uppermost insulating interlayer pattern **306g** is exposed. Portions of the gate electrode layer **372** formed in the opening **360** and on the top surface of the substrate **300** may be etched to obtain the blocking layer pattern **375** and the gate lines **380** (e.g., **380a** to **380f**).

The gate electrode layer **372** may be partially etched by a wet etching process using a hydrogen peroxide-containing solution, for example.

The gate lines **380** may include the GSL, the word line and the SSL sequentially stacked and spaced apart from one another in the first direction. For example, a lowermost gate line **380a** may serve as the GSL. Four gate lines **380b** to **380e** on the GSL may serve as the word lines. An uppermost gate line **380f** on the word line may serve as the SSL.

The gate line **380** at each level may surround the charge trap layer pattern **322**, the tunnel insulation layer pattern **325** and the channel **340**, and may extend in the second direction. The gate line **380** at each level may surround the predetermined number of the channel rows, e.g., four channel rows. Accordingly, a gate line structure may be formed by the gate lines **380** that are stacked in the first direction, surround the predetermined number of the channel rows and extend in the second direction.

Referring to FIG. **36**, an impurity region **301** may be formed in an upper portion of the substrate **300** exposed through the opening **360**, and a second filling layer pattern **385** filling the opening **360** may be formed.

In exemplary embodiments, n-type impurities such as P or As may be implanted through the opening **360** to form the impurity region **301**. The impurity region **301** may serve as a CSL extending in the second direction. In some embodiments, a metal silicide pattern (not illustrated) including, e.g., nickel silicide or cobalt silicide may be further formed on the impurity region **301** to reduce a resistance of the CSL.

A second filling layer sufficiently filling the opening **360** may be formed on the impurity region **301**, the uppermost insulating interlayer pattern **306g** and the pad **350**. An upper portion of the second filling layer may be planarized by a CMP process or an etch-back process until the uppermost insulating interlayer pattern **306g** is exposed to form a second filling layer pattern **385**. The second filling layer may be formed of an insulating material silicon oxide, for example.

23

Referring to FIG. 37, an upper insulation layer 390 may be formed on the uppermost insulating interlayer pattern 306g, the second filling layer pattern 385 and the pad 350. The upper insulation layer 390 may be formed of an insulating material such as silicon oxide by a deposition process such as a CVD process.

A bit line contact 393 may be formed through the upper insulation layer 390 to be electrically connected to the pad 350. A bit line 395 electrically connected to the bit line contact 393 may be formed on the upper insulation layer 390.

A plurality of the bit line contacts 393 may be formed according to the arrangement of the channels 340 or the pads 350. The bit line 395 may extend in the third direction, and may be electrically connected to a plurality of the bit line contacts 393. A plurality of the bit lines 395 may be formed along the second direction.

The bit line contact 393 and the bit line 395 may be formed of metal or metal nitride by a sputtering process or an ALD process, for example.

According to exemplary embodiments as described above, a tunnel insulation layer included in a charge trap-type vertical memory device may be formed using an OSO-layered structure wherein a valence band offset of a band-gap is reduced so that an erase voltage of an erase operation is lowered, and a charge trap in the tunnel insulation layer may be minimized by using a silicon layer as an intermediate layer of the OSO-layered structure. In some exemplary embodiments, an oxide layer, a silicon layer and an oxide layer may be sequentially and successively formed by an in-situ ALD process. Supply times and flow rates of source gases may be controlled so that a thickness of each layer in the tunnel insulation layer may be finely adjusted.

FIG. 38 is a cross-sectional view illustrating a semiconductor device in accordance with some exemplary embodiments of the present inventive concept.

Detailed descriptions on structures and processes substantially the same as or similar to those illustrated with reference to FIG. 21 and FIGS. 22 to 37 are omitted herein. Like reference numerals are used to designate like elements.

Referring to FIG. 38, a tunnel insulation layer pattern 327 may include a first silicon oxide layer pattern 312, a silicon layer pattern 314, a silicon oxynitride layer pattern 318 and a second silicon oxide layer pattern 319 sequentially stacked from an inner sidewall of a charge trap layer pattern 322.

The oxynitride layer pattern 318 may have a thickness smaller than that of the silicon layer pattern 314, and may be interposed between the silicon layer pattern 314 and the second silicon oxide layer pattern 319. Therefore, a band-gap or an erase voltage may be further reduced by an addition of a nitrogen ingredient while preventing a charge trap in the tunnel insulation layer pattern 327.

For example, in a process for the formation of the tunnel insulation layer illustrated with reference to FIG. 26, a nitrogen containing flow including NH_3 and N_2O may be introduced before providing the oxygen flow and the second hydrogen flow for the formation of the second silicon oxide layer 317. A supply time of the nitrogen containing flow may be shorter than that of the oxygen flow and the second hydrogen flow to form a silicon oxynitride layer on the silicon layer 315.

FIG. 39 is a cross-sectional view illustrating a semiconductor device in accordance with some exemplary embodiments.

Detailed descriptions on structures and processes substantially the same as or similar to those illustrated with refer-

24

ence to FIG. 21 and FIGS. 22 to 37 are omitted herein. Like reference numerals are used to designate like elements.

Referring to FIG. 39, a first blocking layer pattern 379 may be disposed on a sidewall of a channel hole 310, and a charge trap layer pattern 322a may be disposed on the first blocking layer pattern 379. A tunnel insulation layer pattern 325a including a first silicon oxide layer pattern 312a, a silicon layer pattern 314a and a second silicon oxide layer pattern 316a may be disposed on the charge trap layer pattern 322a.

A second blocking layer pattern 377 may be formed between a gate line 380 and the first blocking layer pattern 379, and on surfaces of insulating interlayer patterns 306. The second blocking layer pattern 377 may have a shape and a structure substantially the same as the blocking layer pattern 375 illustrated in FIG. 21.

For example, in a process illustrated with reference to FIG. 25, a first blocking layer including silicon oxide or a metal oxide may be formed along a top surface of the mold structure, and the sidewall and a bottom of the channel hole 310 before forming the charge trap layer 311. Accordingly, as illustrated in FIG. 39, the first blocking layer pattern 379 may be formed on the sidewall of the channel hole 310, and the charge trap layer pattern 322a may be formed on the first blocking layer pattern 379.

In some exemplary embodiments, if the first blocking layer 379 is formed, the formation of the second blocking layer pattern 377 may be omitted. In this case, the gate line 380 at each level may be in contact with the insulating interlayer pattern 306 and the first blocking layer pattern 379.

FIGS. 40 and 41 show deposition source gas flow profiles to form a second silicon oxide layer in accordance with some exemplary embodiments of the present inventive concept. For example, FIGS. 40 and 41 show deposition source gas profiles for the formation of the second silicon oxide layer 317 in a process illustrated with reference to FIG. 26.

Referring to FIG. 40, after the formation of the silicon layer 315 in FIG. 26, an introduction of the oxygen flow and the second hydrogen flow (denoted as " O_2+H_2 " in FIG. 40) may be initiated from a specific critical time T_c while providing the second silicon precursor such as HCD continuously in an ALD process chamber. After the critical time T_c , the second silicon precursor may be continuously provided together with the oxygen flow and the second hydrogen flow.

As shown in FIG. 40, the introduction of the oxygen flow and the second hydrogen flow may be delayed for a time denoted as " T_a ", so that the second silicon oxide layer 317 may be formed while preventing oxidation of the silicon layer 315.

In some exemplary embodiments, the supply time of the second silicon precursor (e.g., a sum of T_a and T_b) may be at least twice the supply time of the oxygen flow and the second hydrogen flow (e.g., T_b).

Referring to FIG. 41, the introduction of the oxygen flow and the second hydrogen flow may be initiated from a first time T_{c1} to a second time T_{c2} after the introduction of the second silicon precursor. The second silicon precursor may be continuously provided even after the second time T_{c2} . The introduction of the oxygen flow and the second hydrogen flow may intervene within a limited time so that the second silicon oxide layer 317 having a desired thickness may be formed while suppressing oxidation of the silicon layer 315.

FIGS. 42 and 43 show deposition source gas profiles for forming a silicon oxynitride layer and a second silicon oxide

layer. For example, FIGS. 42 and 43 show deposition source gas profiles for the formation of the silicon oxynitride layer 318 in a process illustrated with reference to FIG. 38.

Referring to FIG. 42, in a process illustrated with reference to FIG. 26, a nitrogen source including NH₃ and N₂O may be provided until a first time Tc1 together with the second silicon precursor for the formation of the second silicon oxide layer 317. Accordingly, a thin silicon oxynitride layer may be additionally formed on the silicon layer 315.

The oxygen flow and the second hydrogen flow may be provided from the first time Tc1 to a second time Tc2 to form the second silicon oxide layer 317. A length until the first time Tc1 may be shorter than a length between the first time Tc1 to the second time Tc2. Thus, the silicon oxynitride layer may be thinner than each of the silicon layer 315 and the second silicon oxide layer 317.

The second silicon precursor may be provided continuously for a predetermined time even after the second time Tc2.

Referring to FIG. 43, the nitrogen source may be provided for a period between a first time Tc1 and a second time Tc2 after the introduction of the second silicon precursor. Accordingly, a thin silicon oxynitride layer may be formed on the silicon layer 315. After the second time Tc2, the oxygen flow and the second hydrogen flow may be introduced together with the second silicon precursor to form the second silicon oxide layer 317 on the silicon oxynitride layer.

A length between the first time Tc1 and the second time Tc2 may be shorter than a length after the second time Tc2. Thus, the silicon oxynitride layer may be thinner than each of the silicon layer 315 and the second silicon oxide layer 317.

According to exemplary embodiments of the present inventive concept, an OSO-layered structure including an oxide layer-a silicon layer-an oxide layer may be employed as a tunnel insulation layer of planar-type or vertical-type non-volatile memory devices. The silicon layer may be thinner than the oxide layer, and may have small valence band offset of a band-gap at the interface between the silicon layer and the oxide layer, and may have a low charge trap property compared to nitride. Therefore, a charge loss and an erase voltage of the memory device may be reduced, and operational and mechanical reliability of the memory device may increase.

In an exemplary embodiment, the floating gate electrode of FIGS. 1 and 2 and the charge trap layer pattern 322 of FIGS. 21, 34-38 and the charge trap layer pattern 322a of FIG. 39 may serve to store charges in a write operation, and in a read operation, an amount of such charges may be read out. The floating gate electrode of FIGS. 1 and 2 and the charge trap layer pattern 322 of FIGS. 21, 34-38 and the charge trap layer pattern 322a of FIG. 39 may be referred to as a charge storage layer pattern.

In an exemplary embodiment,

While the present inventive concept has been shown and described with reference to exemplary embodiments thereof, it will be apparent to those of ordinary skill in the art that various changes in form and detail may be made therein without departing from the spirit and scope of the inventive concept as defined by the following claims.

What is claimed is:

1. A method of manufacturing a semiconductor device, comprising:
 - forming a first silicon oxide layer on a substrate;
 - providing a first silicon precursor and a first hydrogen flow to form a silicon layer on the first silicon oxide layer;
 - providing a second silicon precursor, an oxygen flow and a second hydrogen flow to form a second silicon oxide layer on the silicon layer; and
 - forming a plurality of gate patterns on the second silicon oxide layer.
2. The method of claim 1, wherein each of the first silicon precursor and the second silicon precursor include a chlorosilane-based material.
3. The method of claim 1, wherein the forming of the gate patterns includes:
 - sequentially forming a floating gate layer, a dielectric layer and a control gate layer on the second silicon oxide layer; and
 - partially etching the control gate layer, the dielectric layer and the floating gate layer to form the gate patterns.
4. The method of claim 3, wherein a tunnel insulation layer includes the first silicon oxide layer, the silicon layer and the second silicon oxide layer, and further comprising partially etching a portion of the tunnel insulation layer between two adjacent gate patterns of the plurality of gate patterns.
5. The method of claim 1, further comprising:
 - providing a nitrogen containing source before providing the first hydrogen flow; and
 - forming a silicon oxynitride layer interposed between the first silicon oxide layer and the silicon layer using the nitrogen containing source.
6. A method of manufacturing a semiconductor device, comprising:
 - forming a plurality of insulating interlayers and a plurality of sacrificial layers on a substrate to form a mold structure, wherein each insulating interlayer and each sacrificial layer are alternately and repeatedly stacked on the substrate;
 - forming a channel hole penetrating through the mold structure;
 - forming a charge trap layer on a sidewall of the channel hole;
 - forming a first silicon oxide layer on the charge trap layer;
 - providing a first silicon precursor and a first hydrogen flow to form a silicon layer on the first silicon oxide layer;
 - providing a second silicon precursor, an oxygen flow and a second hydrogen flow to form a second silicon oxide layer on the silicon layer;
 - forming a channel on the second silicon oxide layer, wherein the channel is disposed in the channel hole; and
 - forming a plurality of gate lines by replacing each sacrificial layer with each gate line.
7. The method of claim 6, wherein each of the first silicon precursor and the second silicon precursor include hexachlorodisilane (HCD).
8. The method of claim 6, wherein a supply time of the second silicon precursor is greater than a supply time of the oxygen flow and the second hydrogen flow.
9. The method of claim 8, wherein the supply time of the second silicon precursor is at least twice the supply time of the oxygen flow and the second hydrogen flow.

10. The method of claim 6, wherein the first silicon oxide layer, the silicon layer and the second silicon oxide layer are formed by an in-situ atomic layer deposition (ALD) process.

11. The method of claim 6, further comprising:
providing a nitrogen containing flow before providing the 5
oxygen flow and the second hydrogen flow; and
forming a silicon oxynitride layer interposed between the
silicon layer and the second silicon oxide layer using
the nitrogen containing flow.

12. The method of claim 11, wherein a supply time of the 10
nitrogen containing flow is shorter than a supply time of the
oxygen flow and the second hydrogen flow.

13. The method of claim 6, wherein the second silicon
oxide layer, the silicon layer and the first silicon oxide layer
are provided as a tunnel insulation layer, and 15
further comprising partially removing a portion of the
charge trap layer or the tunnel insulation layer formed
on a bottom of the channel hole before forming the
channel.

* * * * *