

(12) **United States Patent**  
**Bailly et al.**

(10) **Patent No.:** **US 9,980,802 B2**  
(45) **Date of Patent:** **May 29, 2018**

(54) **UMBILICAL HERNIA PROSTHESIS**

(56) **References Cited**

(75) Inventors: **Pierre Bailly**, Caluire-et-Cuire (FR);  
**Gaëtan Romuald**, Bron (FR)

U.S. PATENT DOCUMENTS

(73) Assignee: **SOFRADIM PRODUCTION**, Trevoux (FR)

1,187,158 A 6/1916 Mcginley  
2,153,889 A \* 4/1939 Hames ..... A61B 17/06166  
424/423

(Continued)

(\* ) Notice: Subject to any disclaimer, the term of this patent is extended or adjusted under 35 U.S.C. 154(b) by 260 days.

FOREIGN PATENT DOCUMENTS

(21) Appl. No.: **14/232,378**

CA 1317836 C 5/1993  
CN 101489502 A 7/2009

(Continued)

(22) PCT Filed: **Jun. 29, 2012**

OTHER PUBLICATIONS

(86) PCT No.: **PCT/EP2012/062672**

International Search Report issued in corresponding application No. PCT/EP2012/062672, dated Sep. 4, 2012.

§ 371 (c)(1),  
(2), (4) Date: **Mar. 24, 2014**

(Continued)

(87) PCT Pub. No.: **WO2013/007535**

PCT Pub. Date: **Jan. 17, 2013**

*Primary Examiner* — Gregory Anderson

(65) **Prior Publication Data**

US 2015/0157436 A1 Jun. 11, 2015

(57) **ABSTRACT**

(30) **Foreign Application Priority Data**

Jul. 13, 2011 (FR) ..... 11 56425

The present disclosure relates to a prosthesis comprising: one mesh delimited by a peripheral exterior edge, a frame fastened to said mesh and adopting the shape of said peripheral exterior edge of the mesh, said frame being set back from said peripheral exterior edge and being provided with two hinge points, the line passing through said two hinge points also passing through the center of the mesh and thus forming a line for folding the mesh in two, characterized in that said prosthesis further comprises at least two anchor pieces made of suturable material and located on a single face of the mesh on either side of said folding line, each piece having a fixed part linked to said mesh and a free part, said free part being linked to at least one thread-shaped element.

(51) **Int. Cl.**

**A61F 2/02** (2006.01)  
**A61F 2/00** (2006.01)

(Continued)

(52) **U.S. Cl.**

CPC ..... **A61F 2/0063** (2013.01); **A61B 17/0057** (2013.01); **A61B 17/04** (2013.01);

(Continued)

(58) **Field of Classification Search**

CPC ..... A61F 2/0063; A61B 2017/00597  
See application file for complete search history.

**22 Claims, 10 Drawing Sheets**

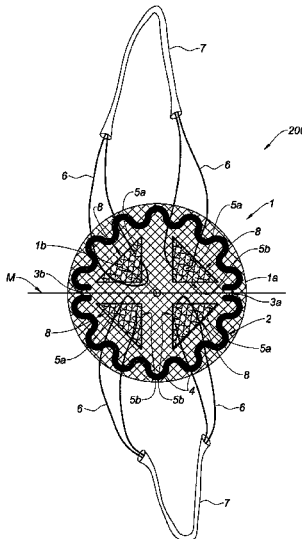

(51)	<b>Int. Cl.</b>		5,304,595 A	4/1994	Rhee et al.
	<i>A61B 17/00</i>	(2006.01)	5,306,500 A	4/1994	Rhee et al.
	<i>A61B 17/04</i>	(2006.01)	5,324,775 A	6/1994	Rhee et al.
	<i>A61B 17/06</i>	(2006.01)	5,328,955 A	7/1994	Rhee et al.
(52)	<b>U.S. Cl.</b>		5,334,527 A	8/1994	Brysk
	CPC .....	<i>A61B 17/06</i> (2013.01); <i>A61B 2017/00597</i>	5,339,657 A	8/1994	McMurray
		(2013.01); <i>A61B 2017/00623</i> (2013.01); <i>A61B</i>	5,350,583 A	9/1994	Yoshizato et al.
		<i>2017/0496</i> (2013.01); <i>A61F 2210/0014</i>	5,356,432 A	10/1994	Rutkow et al.
		(2013.01); <i>A61F 2210/0076</i> (2013.01); <i>A61F</i>	5,368,549 A	11/1994	McVicker
		<i>2220/0008</i> (2013.01); <i>A61F 2250/0031</i>	5,368,602 A	11/1994	de la Torre
		(2013.01); <i>F04C 2270/041</i> (2013.01)	5,370,650 A	12/1994	Tovey et al.
			5,376,375 A	12/1994	Rhee et al.
			5,376,376 A	12/1994	Li
			5,397,331 A	3/1995	Himpens et al.
(56)	<b>References Cited</b>		5,399,361 A	3/1995	Song et al.
	<b>U.S. PATENT DOCUMENTS</b>		5,413,791 A	5/1995	Rhee et al.
			5,425,740 A	6/1995	Hutchinson, Jr.
			5,428,022 A	6/1995	Palefsky et al.
			5,433,996 A	7/1995	Kranzler et al.
			5,441,491 A	8/1995	Verschuur et al.
			5,441,508 A	8/1995	Gazielly et al.
			5,456,693 A	10/1995	Conston et al.
			5,456,711 A	10/1995	Hudson
			5,466,462 A	11/1995	Rosenthal et al.
			5,480,644 A	1/1996	Freed
			5,487,895 A	1/1996	Dapper et al.
			5,490,984 A	2/1996	Freed
			5,512,291 A	4/1996	Li
			5,512,301 A	4/1996	Song et al.
			5,514,181 A	5/1996	Light et al.
			5,522,840 A	6/1996	Krajicek
			5,523,348 A	6/1996	Rhee et al.
			5,536,656 A	7/1996	Kemp et al.
			5,543,441 A	8/1996	Rhee et al.
			5,565,210 A	10/1996	Rosenthal et al.
			5,567,806 A	10/1996	Abdul-Malak et al.
			5,569,273 A	10/1996	Titone et al.
			RE35,399 E	12/1996	Eisenberg
			5,593,441 A	1/1997	Lichtenstein et al.
			5,595,621 A	1/1997	Light et al.
			5,601,571 A	2/1997	Moss
			5,607,474 A	3/1997	Athanasiou et al.
			5,607,590 A	3/1997	Shimizu
			5,614,587 A	3/1997	Rhee et al.
			5,618,551 A	4/1997	Tardy et al.
			5,634,931 A	6/1997	Kugel
			5,639,796 A	6/1997	Lee
			5,665,391 A	9/1997	Lea
			5,667,839 A	9/1997	Berg
			5,676,967 A	10/1997	Williams et al.
			5,681,568 A	10/1997	Goldin et al.
			5,686,090 A	11/1997	Schilder et al.
			5,686,115 A	11/1997	Vournakis et al.
			5,690,675 A	11/1997	Sawyer et al.
			5,695,525 A	12/1997	Mulhauser et al.
			5,697,978 A	12/1997	Sgro
			5,700,476 A	12/1997	Rosenthal et al.
			5,700,477 A	12/1997	Rosenthal et al.
			5,702,416 A	12/1997	Kieturakis et al.
			5,709,934 A	1/1998	Bell et al.
			5,711,960 A	1/1998	Shikinami
			5,716,409 A	2/1998	Debbas
			5,720,981 A	2/1998	Eisinger
			5,732,572 A	3/1998	Litton
			5,743,917 A	4/1998	Saxon
			5,749,895 A	5/1998	Sawyer et al.
			5,752,974 A	5/1998	Rhee et al.
			5,766,246 A	6/1998	Mulhauser et al.
			5,766,631 A	6/1998	Arnold
			5,769,864 A	6/1998	Kugel
			5,771,716 A	6/1998	Schlussel
			5,785,983 A	7/1998	Furlan et al.
			5,800,541 A	9/1998	Rhee et al.
			5,814,328 A	9/1998	Gunasekaran
			5,833,705 A	11/1998	Ken et al.
			5,840,011 A	11/1998	Landgrebe et al.
			5,861,034 A	1/1999	Taira et al.
			5,863,984 A	1/1999	Doillon et al.
			5,869,080 A	2/1999	McGregor et al.

5,116,357 A \* 5/1992 Eberbach ..... A61B 17/0057  
602/76

5,147,374 A 9/1992 Fernandez  
5,162,430 A 11/1992 Rhee et al.  
5,171,273 A 12/1992 Silver et al.  
5,176,692 A 1/1993 Wilk et al.  
5,192,301 A 3/1993 Kamiya et al.  
5,195,542 A 3/1993 Gazielly et al.  
5,196,185 A 3/1993 Silver et al.  
5,201,745 A 4/1993 Tayot et al.  
5,201,764 A 4/1993 Kelman et al.  
5,206,028 A 4/1993 Li  
5,217,493 A 6/1993 Raad et al.  
5,254,133 A 10/1993 Seid  
5,256,418 A 10/1993 Kemp et al.  
5,258,000 A 11/1993 Gianturco  
5,263,983 A 11/1993 Yoshizato et al.

(56)

## References Cited

## U.S. PATENT DOCUMENTS

5,871,767	A	2/1999	Dionne et al.	6,391,060	B1	5/2002	Ory et al.
5,876,444	A	3/1999	Lai	6,391,333	B1	5/2002	Li et al.
5,891,558	A	4/1999	Bell et al.	6,391,939	B2	5/2002	Tayot et al.
5,899,909	A	5/1999	Claren et al.	6,408,656	B1	6/2002	Ory et al.
5,906,937	A	5/1999	Sugiyama et al.	6,410,044	B1	6/2002	Chudzik et al.
5,910,149	A	6/1999	Kuzmak	6,413,742	B1	7/2002	Olsen et al.
5,911,731	A	6/1999	Pham et al.	6,425,924	B1	7/2002	Rousseau
5,916,225	A	6/1999	Kugel	6,428,978	B1	8/2002	Olsen et al.
5,919,232	A	7/1999	Chaffringeon et al.	6,436,030	B2	8/2002	Rehil
5,919,233	A	7/1999	Knopf et al.	6,440,167	B2	8/2002	Shimizu
5,922,026	A	7/1999	Chin	6,443,964	B1	9/2002	Ory et al.
5,931,165	A	8/1999	Reich et al.	6,447,551	B1	9/2002	Goldmann
5,942,278	A	8/1999	Hagedorn et al.	6,447,802	B2	9/2002	Sessions et al.
5,962,136	A	10/1999	Dewez et al.	6,448,378	B2	9/2002	DeVore et al.
5,972,022	A	10/1999	Huxel	6,451,032	B1	9/2002	Ory et al.
RE36,370	E	11/1999	Li	6,451,301	B1	9/2002	Sessions et al.
5,993,844	A	11/1999	Abraham et al.	6,454,787	B1	9/2002	Maddalo et al.
5,994,325	A	11/1999	Roufa et al.	6,458,889	B1	10/2002	Trollsas et al.
5,997,895	A	12/1999	Narotam et al.	6,477,865	B1	11/2002	Matsumoto
6,001,895	A	12/1999	Harvey et al.	6,479,072	B1	11/2002	Morgan et al.
6,008,292	A	12/1999	Lee et al.	6,485,503	B2	11/2002	Jacobs et al.
6,015,844	A	1/2000	Harvey et al.	6,500,464	B2	12/2002	Ceres et al.
6,039,686	A	3/2000	Kovac	6,500,777	B1	12/2002	Wiseman et al.
6,042,534	A	3/2000	Gellman et al.	6,509,031	B1	1/2003	Miller et al.
6,042,592	A	3/2000	Schmitt	6,511,958	B1	1/2003	Atkinson et al.
6,043,089	A	3/2000	Sugiyama et al.	6,514,286	B1	2/2003	Leatherbury et al.
6,051,425	A	4/2000	Morota et al.	6,514,514	B1	2/2003	Atkinson et al.
6,056,688	A	5/2000	Benderev et al.	6,540,773	B2	4/2003	Dong
6,056,970	A	5/2000	Greenawalt et al.	6,541,023	B1	4/2003	Andre et al.
6,057,148	A	5/2000	Sugiyama et al.	6,548,077	B1	4/2003	Gunasekaran
6,063,396	A	5/2000	Kelleher	6,554,855	B1	4/2003	Dong
6,066,776	A	5/2000	Goodwin et al.	6,559,119	B1	5/2003	Burgess et al.
6,066,777	A	5/2000	Benchetrit	6,566,345	B2	5/2003	Miller et al.
6,071,292	A	6/2000	Makower et al.	6,575,988	B2	6/2003	Rousseau
6,077,281	A	6/2000	Das	6,576,019	B1	6/2003	Atala
6,080,194	A	6/2000	Pachence et al.	6,596,002	B2	7/2003	Therin et al.
6,083,522	A	7/2000	Chu et al.	6,596,304	B1	7/2003	Bayon et al.
6,090,116	A	7/2000	D'Aversa et al.	6,599,323	B2	7/2003	Melican et al.
6,113,623	A	9/2000	Sgro	6,599,524	B2	7/2003	Li et al.
6,120,539	A	9/2000	Eldridge et al.	6,599,690	B1	7/2003	Abraham et al.
6,132,765	A	10/2000	DiCosmo et al.	6,610,006	B1	8/2003	Amid et al.
6,143,037	A	11/2000	Goldstein et al.	6,613,348	B1	9/2003	Jain
6,153,292	A	11/2000	Bell et al.	6,616,685	B2	9/2003	Rousseau
6,162,962	A	12/2000	Hinsch et al.	6,623,963	B1	9/2003	Muller et al.
6,165,488	A	12/2000	Tardy et al.	6,630,414	B1	10/2003	Matsumoto
6,171,318	B1	1/2001	Kugel et al.	6,637,437	B1	10/2003	Hungerford et al.
6,174,320	B1	1/2001	Kugel et al.	6,638,284	B1	10/2003	Rousseau et al.
6,176,863	B1	1/2001	Kugel et al.	6,645,226	B1	11/2003	Jacobs et al.
6,179,872	B1	1/2001	Bell et al.	6,652,594	B2	11/2003	Francis et al.
6,180,848	B1	1/2001	Flament et al.	6,652,595	B1	11/2003	Nicolo
6,197,325	B1	3/2001	MacPhee et al.	6,653,450	B1	11/2003	Berg et al.
6,197,934	B1	3/2001	DeVore et al.	6,656,206	B2	12/2003	Corcoran et al.
6,197,935	B1	3/2001	Doillon et al.	6,660,280	B1	12/2003	Allard et al.
6,210,439	B1	4/2001	Firmin et al.	6,669,735	B1	12/2003	Pelissier
6,214,020	B1	4/2001	Mulhauser et al.	6,670,018	B2	12/2003	Fujita et al.
6,221,109	B1	4/2001	Geistlich et al.	6,682,760	B2	1/2004	Noff et al.
6,224,616	B1	5/2001	Kugel	6,685,714	B2	2/2004	Rousseau
6,241,768	B1	6/2001	Agarwal et al.	6,706,684	B1	3/2004	Bayon et al.
6,258,124	B1	7/2001	Darois et al.	6,706,690	B2	3/2004	Reich et al.
6,262,332	B1	7/2001	Ketharanathan	6,712,859	B2	3/2004	Rousseau et al.
6,264,702	B1	7/2001	Ory et al.	6,719,795	B1	4/2004	Cornwall et al.
6,267,772	B1	7/2001	Mulhauser et al.	6,723,335	B1	4/2004	Moehlenbruck et al.
6,270,530	B1	8/2001	Eldridge et al.	6,726,660	B2	4/2004	Hessel et al.
6,277,397	B1	8/2001	Shimizu	6,730,299	B1	5/2004	Tayot et al.
6,280,453	B1	8/2001	Kugel et al.	6,736,823	B2	5/2004	Darois et al.
6,287,316	B1	9/2001	Agarwal et al.	6,736,854	B2	5/2004	Vadurro et al.
6,290,708	B1	9/2001	Kugel et al.	6,737,371	B1	5/2004	Planck et al.
6,306,079	B1	10/2001	Trabucco	6,743,435	B2	6/2004	DeVore et al.
6,306,424	B1	10/2001	Vyakarnam et al.	6,746,458	B1	6/2004	Cloud
6,312,474	B1	11/2001	Francis et al.	6,752,834	B2	6/2004	Geistlich et al.
6,319,264	B1	11/2001	Tormala et al.	6,755,868	B2	6/2004	Rousseau
6,328,686	B1	12/2001	Kovac	6,773,723	B1	8/2004	Spiro et al.
6,334,872	B1	1/2002	Termin et al.	6,783,554	B2	8/2004	Amara et al.
6,371,975	B2	4/2002	Cruise et al.	6,790,213	B2	9/2004	Cherok et al.
6,383,201	B1	5/2002	Dong	6,790,454	B1	9/2004	Abdul Malak et al.
				6,800,082	B2	10/2004	Rousseau
				6,833,408	B2	12/2004	Sehl et al.
				6,835,336	B2	12/2004	Watt
				6,852,330	B2	2/2005	Bowman et al.

(56)

References Cited

U.S. PATENT DOCUMENTS

6,869,938 B1	3/2005	Schwartz et al.	8,470,355 B2	6/2013	Skalla et al.
6,872,227 B2	3/2005	Sump et al.	8,562,633 B2	10/2013	Cully et al.
6,893,653 B2	5/2005	Abraham et al.	8,574,627 B2	11/2013	Martakos et al.
6,896,904 B2	5/2005	Spiro et al.	8,709,094 B2	4/2014	Stad et al.
6,926,723 B1	8/2005	Mulhauser et al.	8,734,471 B2	5/2014	Deitch
6,936,276 B2	8/2005	Spiro et al.	8,753,360 B2	6/2014	Gleiman et al.
6,939,562 B2	9/2005	Spiro et al.	8,758,800 B2	6/2014	Stopek et al.
6,949,625 B2	9/2005	Tayot	8,784,294 B2	7/2014	Goddard
6,966,918 B1	11/2005	Schuldt-Hempe et al.	8,814,887 B2	8/2014	Walther et al.
6,971,252 B2	12/2005	Therin et al.	8,828,092 B2	9/2014	Toso et al.
6,974,679 B2	12/2005	Andre et al.	8,834,864 B2	9/2014	Odar et al.
6,974,862 B2	12/2005	Ringeisen et al.	8,846,060 B2	9/2014	Archibald et al.
6,977,231 B1	12/2005	Matsuda	8,865,215 B2	10/2014	Ladet et al.
6,984,392 B2	1/2006	Bechert et al.	8,877,233 B2	11/2014	Obermiller et al.
6,988,386 B1	1/2006	Okawa et al.	8,911,504 B2	12/2014	Mathisen et al.
7,011,688 B2	3/2006	Gryska et al.	8,920,370 B2	12/2014	Sholev et al.
7,021,086 B2	4/2006	Ory et al.	8,945,663 B2	2/2015	Pacetti
7,022,358 B2	4/2006	Eckmayer et al.	8,956,373 B2	2/2015	Ford et al.
7,025,063 B2	4/2006	Snitkin et al.	8,962,006 B2	2/2015	Bayon et al.
7,041,868 B2	5/2006	Greene et al.	8,968,762 B2	3/2015	Ladet et al.
7,060,103 B2	6/2006	Carr, Jr. et al.	8,979,935 B2	3/2015	Lozier et al.
RE39,172 E	7/2006	Bayon et al.	9,034,357 B2	5/2015	Stopek
7,070,558 B2	7/2006	Gellman et al.	9,113,993 B2	8/2015	Lee
7,087,065 B2	8/2006	Ulmsten et al.	9,211,175 B2	12/2015	Stopek et al.
7,094,261 B2	8/2006	Zotti et al.	9,216,075 B2	12/2015	Bailly et al.
7,098,315 B2	8/2006	Schauffler	2002/0077661 A1	6/2002	Saadat
7,101,381 B2	9/2006	Ford et al.	2002/0087174 A1	7/2002	Capello
7,115,220 B2	10/2006	Dubson et al.	2002/0095218 A1	7/2002	Carr et al.
7,156,804 B2	1/2007	Nicolo	2003/0086975 A1	5/2003	Ringeisen
7,156,858 B2	1/2007	Schuldt-Hempe et al.	2003/0114937 A1	6/2003	Leatherbury et al.
7,175,852 B2	2/2007	Simmoteit et al.	2003/0133967 A1	7/2003	Ruszczak et al.
7,192,604 B2	3/2007	Brown et al.	2003/0225355 A1	12/2003	Butler
7,207,962 B2	4/2007	Anand et al.	2004/0019360 A1*	1/2004	Farnsworth ..... A61F 2/0063 606/151
7,214,765 B2	5/2007	Ringeisen et al.	2004/0034373 A1	2/2004	Schuldt-Hempe et al.
7,226,611 B2	6/2007	Yura et al.	2004/0054376 A1	3/2004	Ory et al.
7,229,453 B2	6/2007	Anderson et al.	2004/0059356 A1	3/2004	Gingras
7,252,837 B2	8/2007	Guo et al.	2004/0101546 A1	5/2004	Gorman et al.
7,279,177 B2	10/2007	Looney et al.	2005/0002893 A1	1/2005	Goldmann
7,331,199 B2	2/2008	Ory et al.	2005/0021058 A1	1/2005	Negro
7,393,319 B2	7/2008	Merade et al.	2005/0085924 A1	4/2005	Darois et al.
7,556,598 B2	7/2009	Rao	2005/0113849 A1	5/2005	Popadiuk et al.
7,594,921 B2	9/2009	Browning	2005/0137512 A1	6/2005	Campbell et al.
7,614,258 B2	11/2009	Cherok et al.	2005/0142161 A1	6/2005	Freeman et al.
7,615,065 B2	11/2009	Priewe et al.	2005/0148963 A1	7/2005	Brennan
7,662,169 B2	2/2010	Wittmann	2005/0175659 A1	8/2005	Macomber et al.
7,670,380 B2	3/2010	Cauthen, III	2005/0232979 A1	10/2005	Shoshan
7,682,381 B2	3/2010	Rakos et al.	2005/0267521 A1	12/2005	Forsberg
7,709,017 B2	5/2010	Tayot	2005/0288691 A1	12/2005	Leiboff
7,718,556 B2	5/2010	Matsuda et al.	2006/0116696 A1	6/2006	Odermatt et al.
7,732,354 B2	6/2010	Fricke et al.	2006/0135921 A1	6/2006	Wieroinski et al.
7,785,334 B2	8/2010	Ford et al.	2006/0147501 A1	7/2006	Hillas et al.
7,789,888 B2	9/2010	Bartee et al.	2006/0195010 A1	8/2006	Arnal et al.
7,799,767 B2	9/2010	Lamberti et al.	2006/0216320 A1	9/2006	Kitazono et al.
7,806,905 B2	10/2010	Ford et al.	2006/0252981 A1	11/2006	Matsuda et al.
7,824,420 B2	11/2010	Eldridge et al.	2006/0253203 A1	11/2006	Alvarado
7,828,854 B2	11/2010	Rousseau et al.	2006/0282103 A1	12/2006	Fricke et al.
7,900,484 B2	3/2011	Cherok et al.	2007/0088391 A1	4/2007	McAlexander et al.
7,931,695 B2	4/2011	Ringeisen	2007/0129736 A1	6/2007	Solecki
8,048,441 B2	11/2011	Craig et al.	2007/0198040 A1	8/2007	Buevich et al.
8,052,759 B2	11/2011	Dupic et al.	2007/0299538 A1	12/2007	Roerber
8,079,023 B2	12/2011	Chen	2008/0091276 A1	4/2008	Deusch et al.
8,100,924 B2	1/2012	Browning	2008/0109017 A1	5/2008	Herweck et al.
8,123,817 B2	2/2012	Intoccia et al.	2008/0113001 A1	5/2008	Herweck et al.
8,142,515 B2	3/2012	Therin et al.	2008/0147099 A1*	6/2008	Uen ..... A61F 2/0063 606/151
8,157,821 B2	4/2012	Browning	2008/0147200 A1	6/2008	Rousseau et al.
8,157,822 B2	4/2012	Browning	2008/0172071 A1	7/2008	Barker
8,182,545 B2	5/2012	Cherok et al.	2008/0255593 A1	10/2008	St-Germain
8,197,837 B2	6/2012	Jamiolkowski et al.	2009/0035341 A1	2/2009	Wegener et al.
8,206,632 B2	6/2012	Rousseau et al.	2009/0036996 A1	2/2009	Roerber
8,215,310 B2	7/2012	Browning	2009/0068250 A1	3/2009	Gravagna et al.
8,317,872 B2	11/2012	Adams	2009/0105526 A1	4/2009	Piroli Torelli et al.
8,323,675 B2	12/2012	Greenawalt	2009/0163936 A1	6/2009	Yang et al.
8,343,232 B2	1/2013	Adzich et al.	2009/0187197 A1	7/2009	Roerber et al.
8,366,787 B2	2/2013	Brown et al.	2009/0192530 A1	7/2009	Adzich et al.
8,435,307 B2	5/2013	Paul	2009/0204129 A1	8/2009	Fronio
			2009/0216338 A1	8/2009	Gingras et al.
			2009/0270999 A1	10/2009	Brown

(56)

References Cited

U.S. PATENT DOCUMENTS

2009/0281558	A1	11/2009	Li	
2009/0318752	A1	12/2009	Evans et al.	
2010/0104608	A1	4/2010	Abuzaina et al.	
2010/0318108	A1	12/2010	Datta et al.	
2011/0015760	A1	1/2011	Kullas	
2011/0144667	A1*	6/2011	Horton	A61F 2/0063 606/151
2011/0190795	A1	8/2011	Hotter et al.	
2011/0236460	A1	9/2011	Stopek et al.	
2011/0238094	A1	9/2011	Thomas et al.	
2011/0251699	A1	10/2011	Ladet	
2011/0257666	A1	10/2011	Ladet et al.	
2012/0016388	A1	1/2012	Houard et al.	
2012/0029537	A1	2/2012	Mortarino	
2012/0065727	A1	3/2012	Reneker et al.	
2012/0082712	A1	4/2012	Stopek et al.	
2012/0116425	A1	5/2012	Intoccia et al.	
2012/0150204	A1	6/2012	Mortarino et al.	
2012/0165937	A1	6/2012	Montanari et al.	
2012/0179175	A1	7/2012	Hammell	
2012/0179176	A1	7/2012	Wilson et al.	
2012/0197415	A1	8/2012	Montanari et al.	
2014/0044861	A1	2/2014	Boey et al.	
2014/0364684	A1	12/2014	Lecuire	

FOREIGN PATENT DOCUMENTS

CN	201879864	U	6/2011	EP	1561480	A2	8/2005
DE	19544162	C1	4/1997	EP	1645232	A1	4/2006
DE	19718903	A1	12/1997	EP	1674048	A1	6/2006
DE	19636961	A1	3/1998	EP	1691606	A1	8/2006
DE	19751733	A1	12/1998	EP	1782848	A2	5/2007
DE	19832634	A1	1/2000	EP	2229918	A1	9/2010
DE	101 20 942	A1	10/2001	FR	2244853	A1	4/1975
DE	10019604	A1	10/2001	FR	2257262	A1	8/1975
DE	10120942	A1	10/2001	FR	2 308 349	A1	11/1976
DE	10043396	C1	6/2002	FR	2453231	A1	10/1980
EP	0248544	A1	12/1987	FR	2612392	A1	9/1988
EP	0263360	A2	4/1988	FR	2715309	A1	7/1995
EP	0276890	A2	8/1988	FR	2715405	A1	7/1995
EP	0372969	A1	6/1990	FR	2 724 563	A1	3/1996
EP	0531742	A1	3/1993	FR	2730406	A1	8/1996
EP	544485	A1	6/1993	FR	2744906	A1	8/1997
EP	0552576	A1	7/1993	FR	2766698	A1	2/1999
EP	0611561	A1	8/1994	FR	2771622	A1	6/1999
EP	614650	A2	9/1994	FR	2773057	A1	7/1999
EP	0621014	A1	10/1994	FR	2774277	A1	8/1999
EP	0625891	A1	11/1994	FR	2779937	A1	12/1999
EP	0637452	A1	2/1995	FR	2859624	A1	3/2005
EP	0664132	A1	7/1995	FR	2863277	A1	6/2005
EP	0705878	A2	4/1996	FR	2876020	A1	4/2006
EP	0719527	A1	7/1996	FR	2884706	A1	10/2006
EP	0774240	A1	5/1997	FR	2929834	A1	10/2009
EP	0797962	A2	10/1997	FR	2 951 069	A1	4/2011
EP	0800791	A1	10/1997	FR	2 953 709	A1	6/2011
EP	827724	A2	3/1998	GB	1174814	A	12/1969
EP	0836838	A1	4/1998	GB	2 051 153	A	1/1981
EP	0847727	A1	6/1998	GB	2306110	A	4/1997
EP	0876808	A1	11/1998	JP	H0332677	A	2/1991
EP	0895762	A2	2/1999	JP	H05237128	A	9/1993
EP	898944	A2	3/1999	JP	H09137380	A	5/1997
EP	1017415	A1	7/2000	JP	H11146888	A	6/1999
EP	1036545	A2	9/2000	JP	2008538300	A	10/2008
EP	1052319	A1	11/2000	JP	2010-508121	A	3/2010
EP	1055757	A1	11/2000	JP	2011078767	A	4/2011
EP	1090590	A2	4/2001	WO	89/02445	A1	3/1989
EP	1 216 717	A1	6/2002	WO	89/08467	A1	9/1989
EP	1 216 718	A1	6/2002	WO	90/12551	A1	11/1990
EP	0194192	A1	6/2002	WO	92/06639	A2	4/1992
EP	0693523	B1	11/2002	WO	92/20349	A1	11/1992
EP	1273312	A2	1/2003	WO	93/11805	A1	6/1993
EP	1315468	A2	6/2003	WO	93/10731	A1	6/1993
EP	1382728	A1	1/2004	WO	93/18174	A1	9/1993
EP	1484070	A1	12/2004	WO	94/17747	A1	8/1994
				WO	95/07666	A1	3/1995
				WO	95/18638	A1	7/1995
				WO	95/32687	A1	12/1995
				WO	96/03091	A1	2/1996
				WO	96/08277	A1	3/1996
				WO	96/09795	A1	4/1996
				WO	96/14805	A1	5/1996
				WO	96/41588	A1	12/1996
				WO	97/35533	A1	10/1997
				WO	9831345	A1	7/1998
				WO	98/35632	A1	8/1998
				WO	98/49967	A1	11/1998
				WO	99/05990	A1	2/1999
				WO	99/06079	A1	2/1999
				WO	99/06080	A1	2/1999
				WO	99/51163	A1	10/1999
				WO	00/16821	A1	3/2000
				WO	00/67663	A1	11/2000
				WO	01/15625	A1	3/2001
				WO	01/80773	A1	11/2001
				WO	01/81667	A1	11/2001
				WO	02/007648	A1	1/2002
				WO	0217853	A2	3/2002
				WO	02/078568	A1	10/2002
				WO	03/002168	A1	1/2003
				WO	2004004600	A1	1/2004
				WO	2004071349	A2	8/2004
				WO	2004078120	A2	9/2004
				WO	2004103212	A1	12/2004
				WO	200511280	A1	2/2005
				WO	2005013863	A2	2/2005
				WO	2005018698	A1	3/2005

(56)

## References Cited

## FOREIGN PATENT DOCUMENTS

WO	2005048708	A1	6/2005
WO	2005105172	A1	11/2005
WO	2006018552	A1	2/2006
WO	2006023444	A2	3/2006
WO	2006/040760	A2	4/2006
WO	2007048099	A2	4/2007
WO	2009031035	A2	3/2009
WO	2009071998	A2	6/2009
WO	2010043978	A2	4/2010
WO	2010043980	A2	4/2010
WO	2011007062	A1	1/2011
WO	2011026987	A1	3/2011
WO	2011038740	A1	4/2011

## OTHER PUBLICATIONS

Japanese Office Action dated May 2, 2016 in corresponding Japanese Patent Application No. 2014-519494, together with English translation, 9 pages.

Malette, W. G. et al., "Chitosan, A New Hemostatic," *Ann Th. Surg.*, Jul. 1983, pp. 55-58, 36.

Langenbech, M. R. et al., "Comparison of biomaterials in the early postoperative period," *Surg Endosc.*, May 2003, pp. 1105-1109, 17 (7).

Bracco, P. et al., "Comparison of polypropylene and polyethylene terephthalate (Dacron) meshes for abdominal wall hernia repair: A chemical and morphological study," *Hernia*, 2005, pp. 51-55, 9 (1), published online Sep. 2004.

Klinge, U. et al., "Foreign Body Reaction to Meshes Used for the Repair of Abdominal Wall Hernias," *Eur J. Surg*, Sep. 1999, pp. 665-673, 165.

Logeart, D. et al., "Fucans, sulfated polysaccharides extracted from brown seaweeds, inhibit vascular smooth muscle cell proliferation. II. Degradation and molecular weight effect," *Eur. J. Cell. Biol.*, Dec. 1997, pp. 385-390, 74(4).

Haneji, K. et al., "Fucoidan extracted from *Cladosiphon Okamuraanus Tokida* Induces Apoptosis of Human T-cell Leukemia Virus Type 1-Infected T-Cell Lines and Primary Adult T-Cell Leukemia Cells," *Nutrition and Cancer*, 2005, pp. 189-201, 52(2), published online Nov. 2009.

Junge, K. et al., "Functional and Morphologic Properties of a Modified Mesh for Inguinal Hernia Repair," *World J. Surg.*, Sep. 2002, pp. 1472-1480, 26.

Klinge, U. et al., "Functional and Morphological Evaluation of a Low-Weight, Monofilament Polypropylene Mesh for Hernia Repair," *J. Biomed. Mater. Res.*, Jan. 2002, pp. 129-136, 63.

Welty, G. et al., "Functional impairment and complaints following incisional hernia repair with different polypropylene meshes," *Hernia*, Aug. 2001; pp. 142-147, 5.

Varum, K. et al., "In vitro degradation rates of partially N-acetylated chitosans in human serum," *Carbohydrate Research*, Mar. 1997, pp. 99-101, 299.

Haroun-Bouhedja, F. et al., "In Vitro Effects of Fucans on MDA-MB231 Tumor Cell Adhesion and Invasion," *Anticancer Res.*, Jul.-Aug. 2002, pp. 2285-2292, 22(4).

Scheidbach, H. et al., "In vivo studies comparing the biocompatibility of various polypropylene meshes and their handling properties during endoscopic total extraperitoneal (TEP) patchplasty: An experimental study in pigs," *Surg. Endosc.*, Feb. 2004, pp. 211-220, 18(2).

Blondin, C. et al., "Inhibition of Complement Activation by Natural Sulfated Polysaccharides (Fucans) from Brown Seaweed," *Molecular Immuol.*, Mar. 1994, pp. 247-253, 31(4).

Zvyagintseva, T. et al., "Inhibition of complement activation by water-soluble polysaccharides of some far-eastern brown seaweeds," *Comparative Biochem and Physiol*, Jul. 2000, pp. 209-215, 126(3).

Rosen, M. et al., "Laparoscopic component separation in the single-stage treatment of infected abdominal wall prosthetic removal," *Hernia*, 2007, pp. 435-440, 11, published online Jul. 2007.

Amid, P., "Lichtenstein tension-free hernioplasty: Its inception, evolution, and principles," *Hernia*, 2004; pp. 1-7, 8, published online Sep. 2003.

Boisson-Vidal, C. et al., "Neoangiogenesis Induced by Progenitor Endothelial Cells: Effect of Fucoidan From Marine Algae," *Cardiovascular & Hematological Agents in Medicinal Chem.*, Jan. 2007, pp. 67-77, 5(1).

O'Dwyer, P. et al., "Randomized clinical trial assessing impact of a lightweight or heavyweight mesh on chronic pain after inguinal hernia repair," *Br. J. Surg.*, Feb. 2005, pp. 166-170, 92(2).

Muzzarelli, R. et al., "Reconstruction of parodontal tissue with chitosan," *Biomaterials*, Nov. 1989, pp. 598-604, 10.

Haroun-Bouhedja, F. et al., "Relationship between sulfate groups and biological activities of fucans," *Thrombosis Res.*, Dec. 2000, pp. 453-459, 100(5).

Blondin, C. et al., "Relationships between chemical characteristics and anticomplementary activity of fucans," *Biomaterials*, Mar. 1996, pp. 597-603, 17(6).

Strand, S. et al., "Screening of Chitosans and Conditions for Bacterial Flocculation," *Biomacromolecules*, Mar. 2001, 126-133, 2.

Kanabar, V. et al., "Some structural determinants of the antiproliferative effect of heparin-like molecules on human airway smooth muscle," *Br. J. Pharmacol.*, Oct. 2005, pp. 370-377, 146(3).

Hirano, S. et al., "The blood biocompatibility of chitosan and N-acylchitosans," *J. Biomed. Mater. Res.*, Apr. 1985, 413-417, 19.

Rao, B. et al., "Use of chitosan as a biomaterial: Studies on its safety and hemostatic potential," *J. Biomed. Mater. Res.*, Jan. 1997, pp. 21-28, 34.

Prokop, A. et al., "Water Soluble Polymers for Immunoisolation I: Complex Coacervation and Cytotoxicity," *Advances in Polymer Science*, Jul. 1998, pp. 1-51, 136.

Collins, R. et al., "Use of collagen film as a dural substitute: Preliminary animal studies," *Journal of Biomedical Materials Research*, Feb. 1991, pp. 267-276, vol. 25.

Dr. S. Raz, "The Karl Mayer Guide to Technical Textiles," Jan. 2000, pp. 1-36, Obertshausen, Germany.

Chen, G. et al., "A Hybrid Network of Synthetic Polymer Mesh and Collagen Sponge," *The Royal Society of Chemistry 2000, Chem. Commun.*, Jul. 2000, pp. 1505-1506.

\* cited by examiner

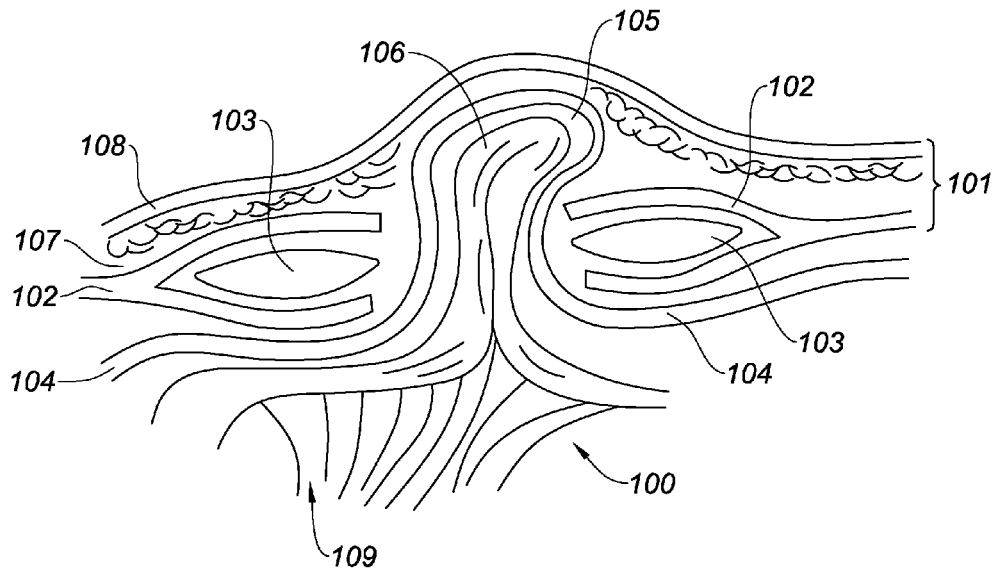

Fig. 1

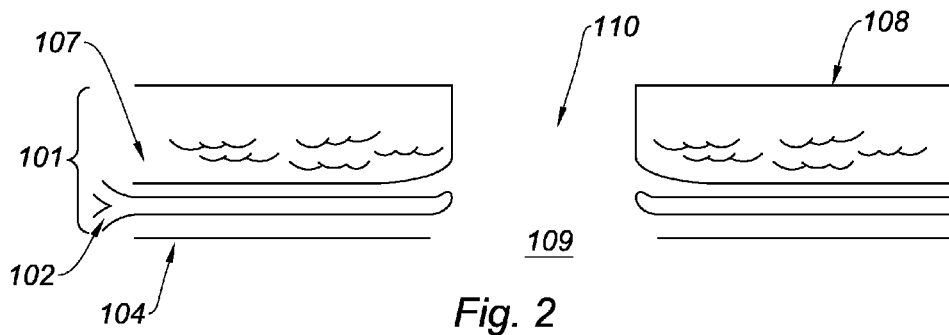

Fig. 2

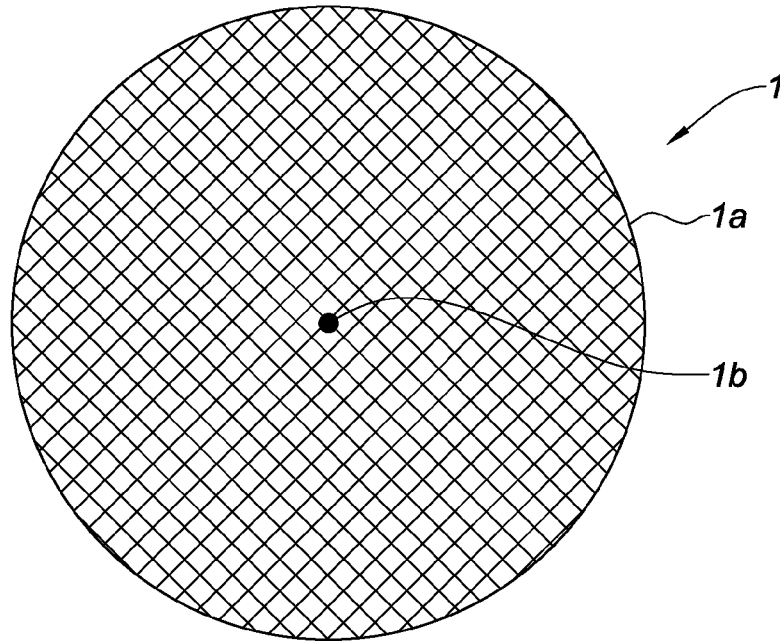

Fig. 3

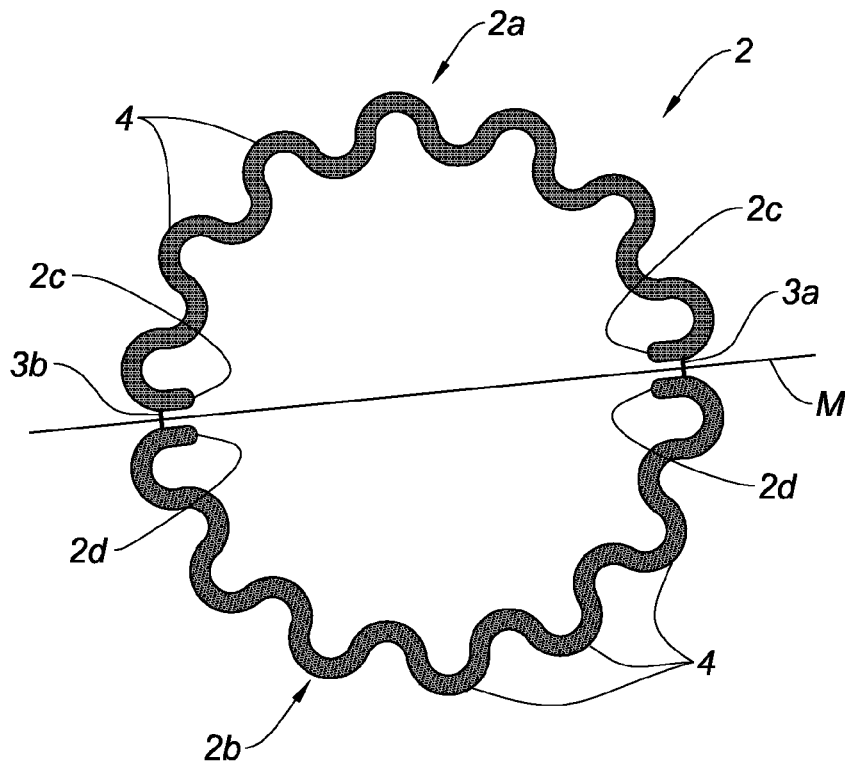
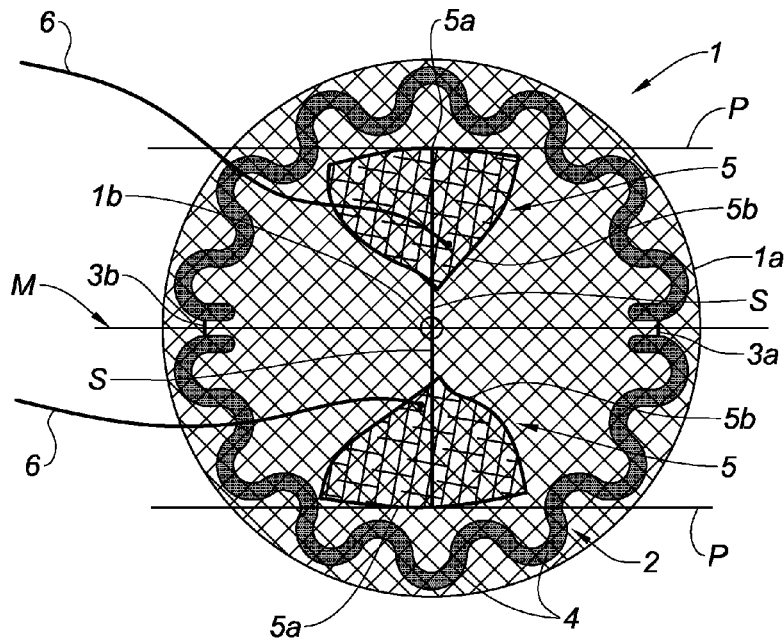
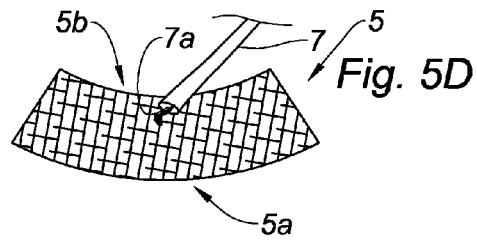
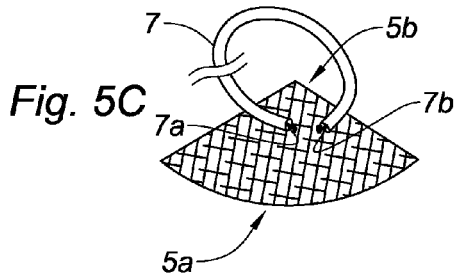
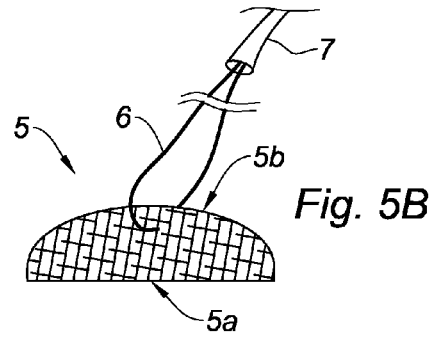
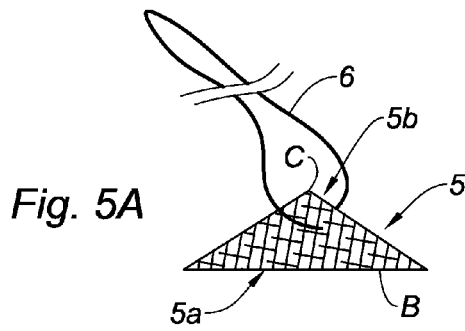

Fig. 4





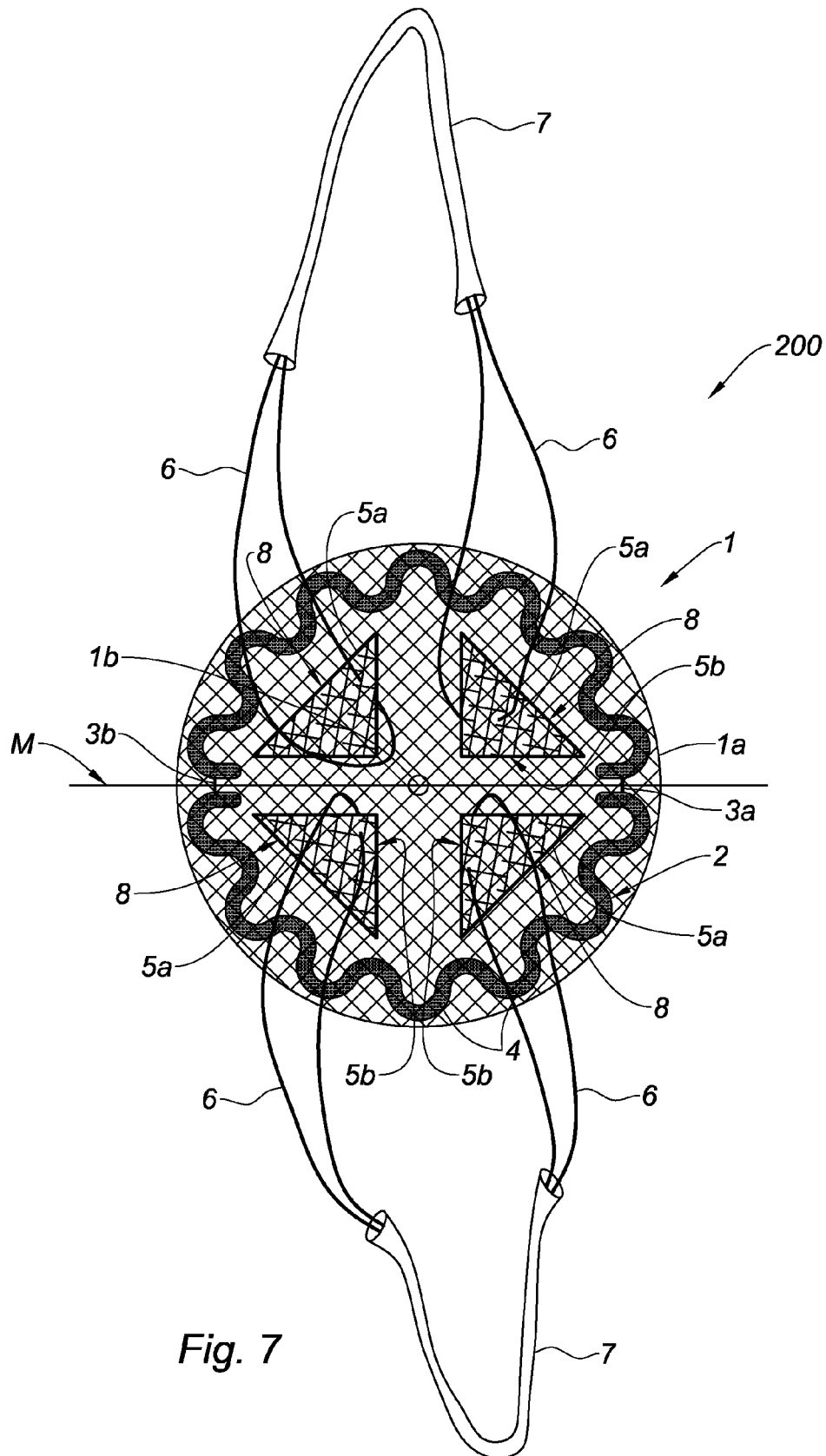

Fig. 7

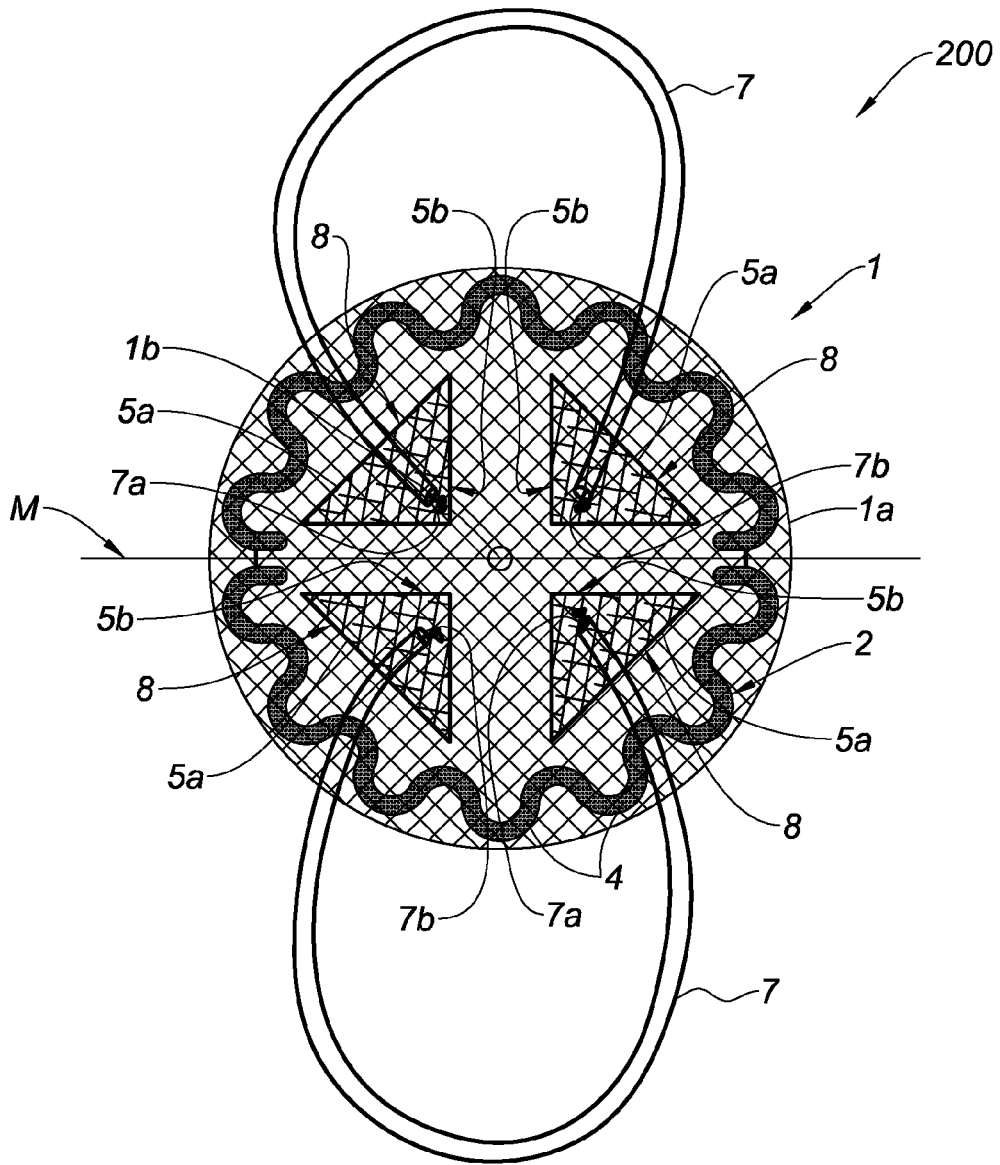

Fig. 8

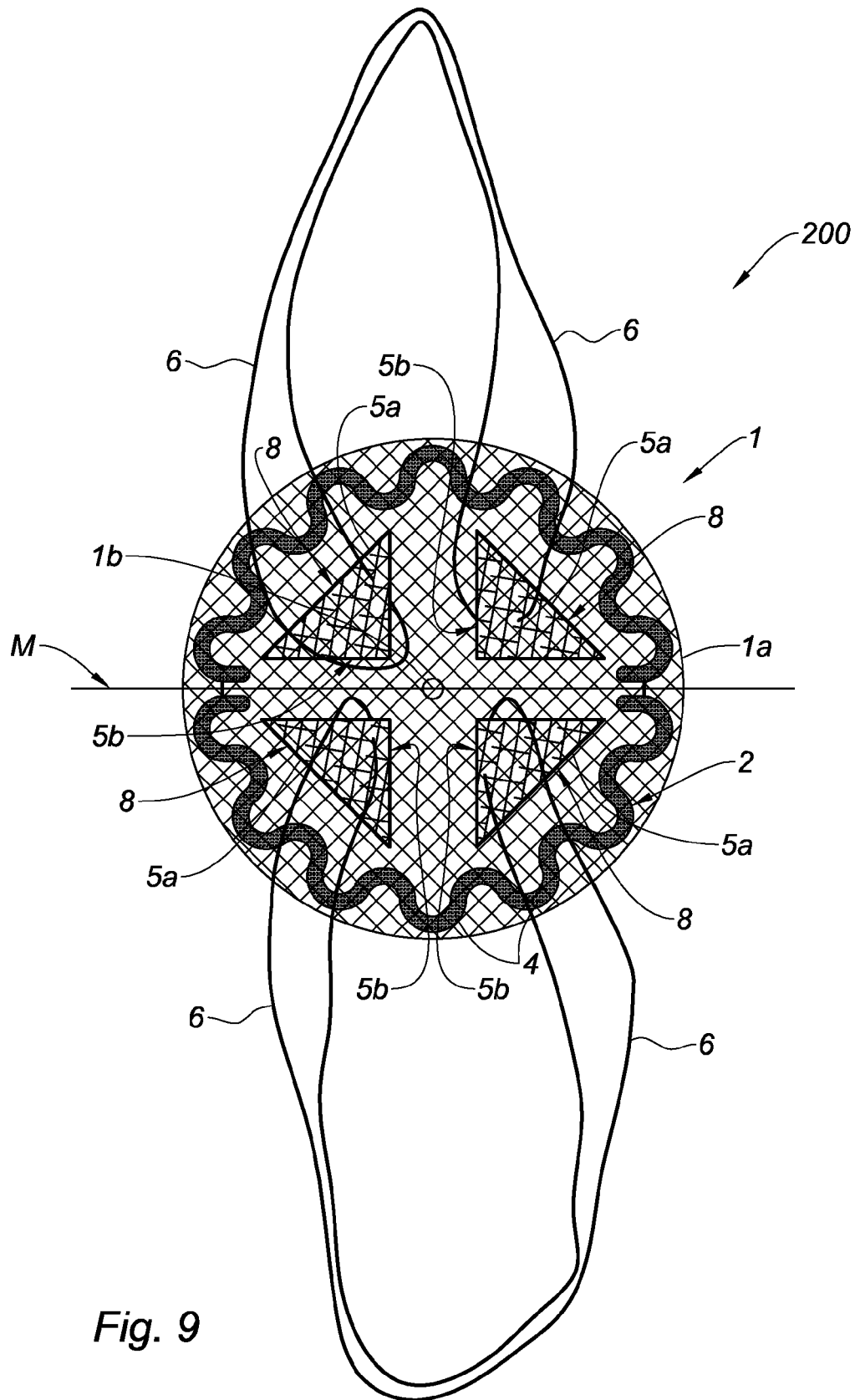

Fig. 9

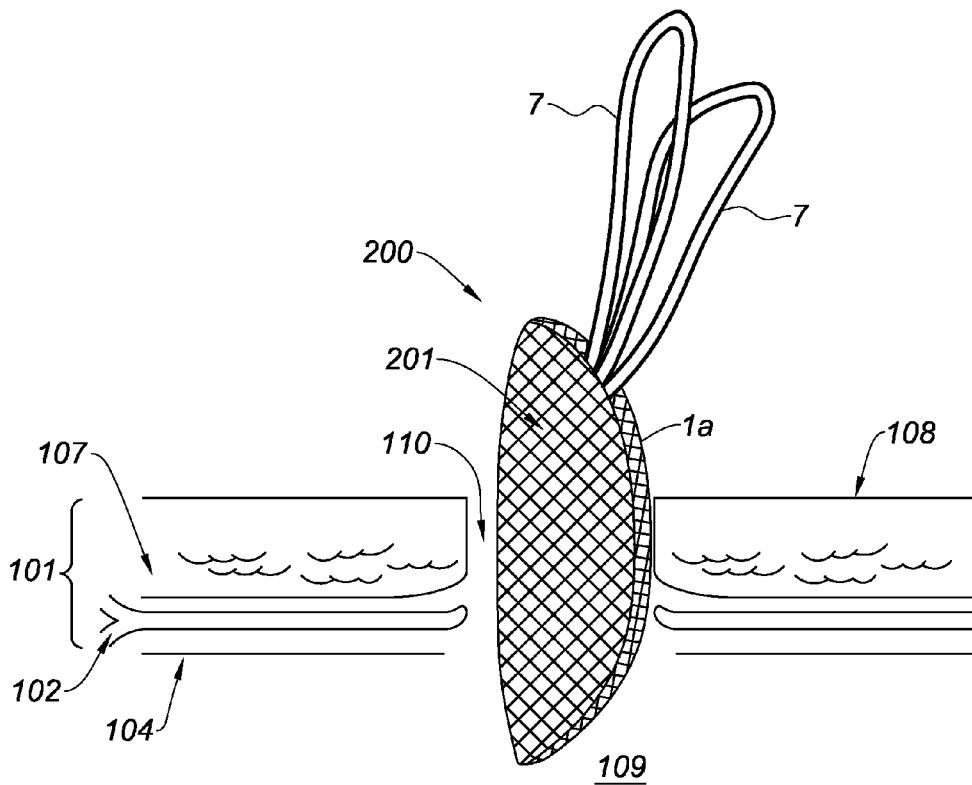

Fig. 10

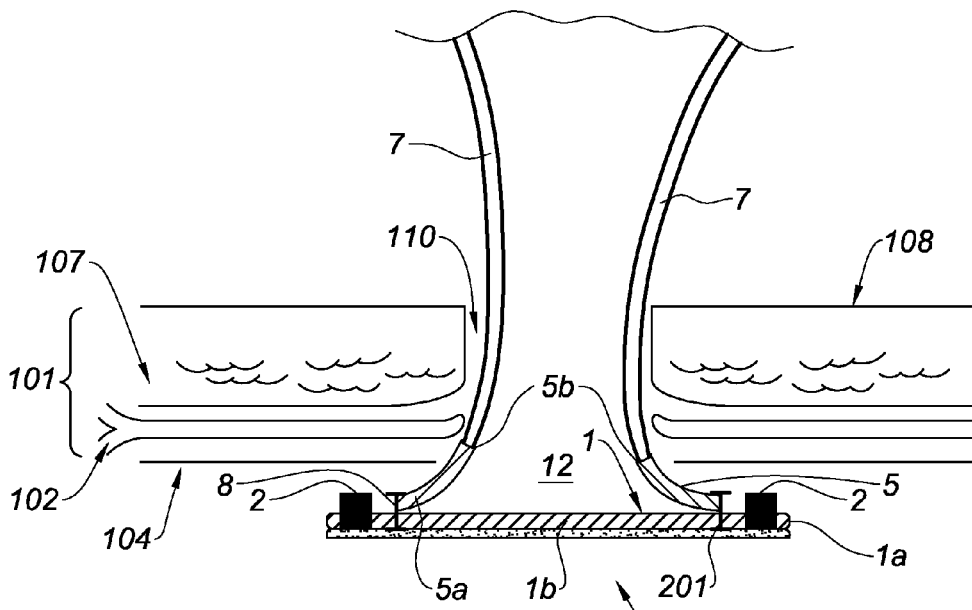

Fig. 11



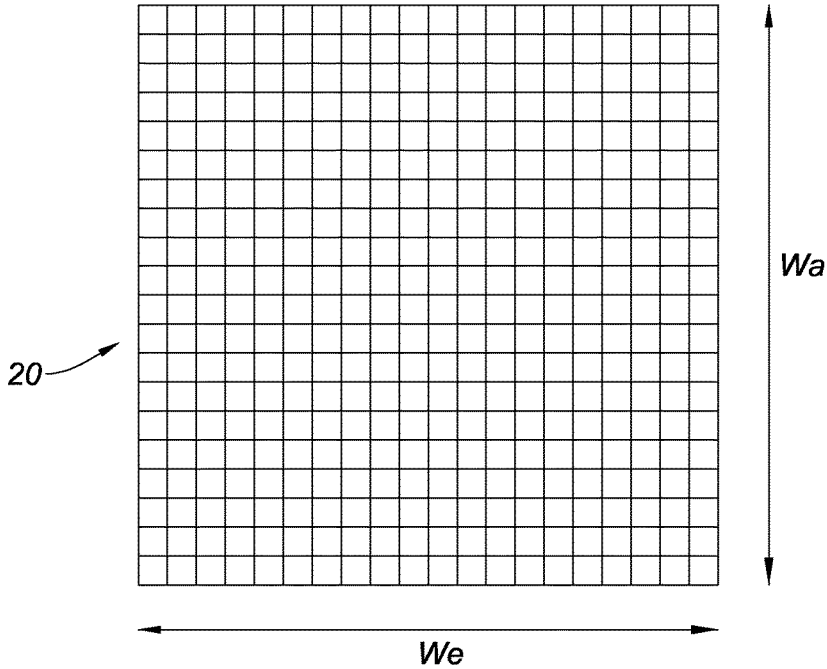

Fig. 14

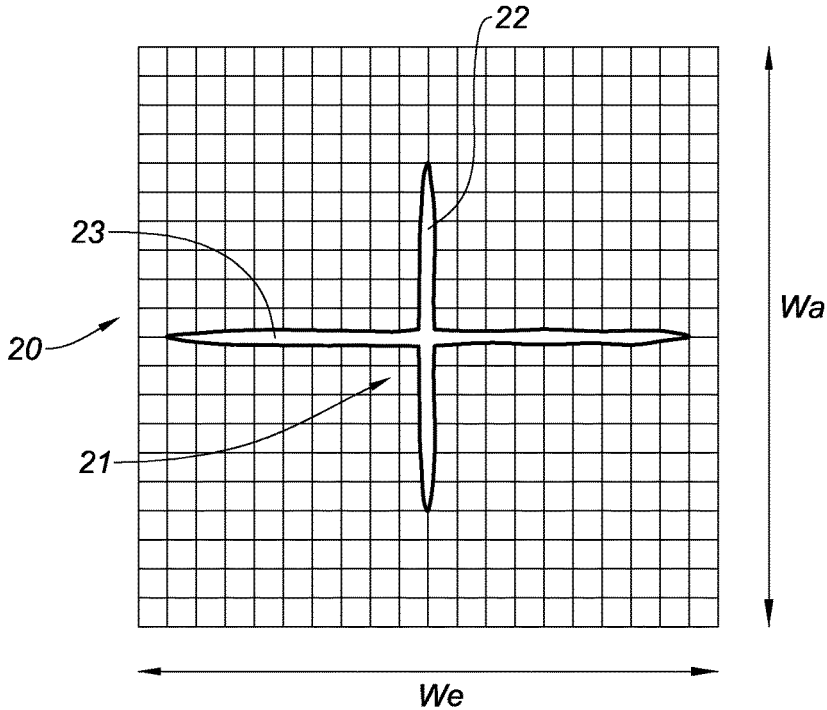

Fig. 15

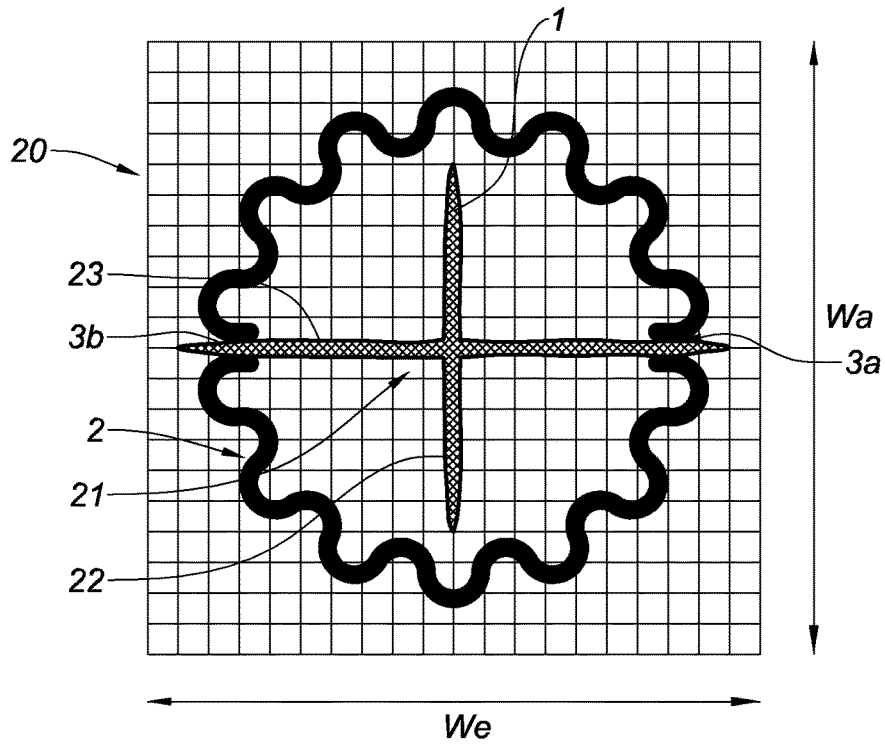

Fig. 16

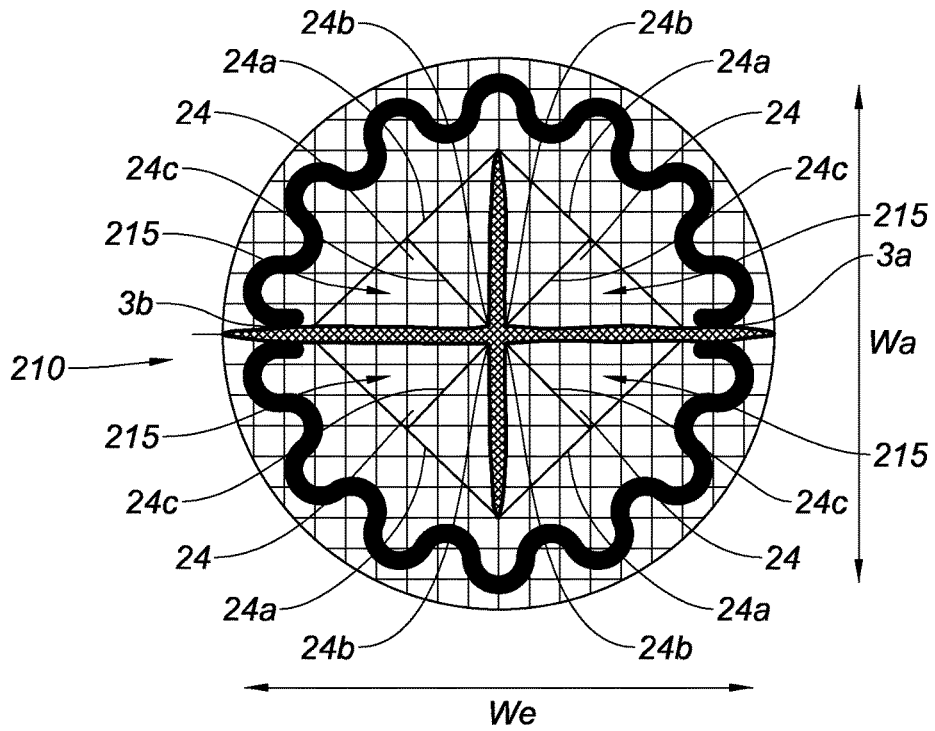

Fig. 17



**UMBILICAL HERNIA PROSTHESIS**

The present invention provides a prosthesis, for repairing hernias, for example, comprising a mesh and a member for reinforcing the mesh.

In humans the abdominal wall consists of fat and muscles interconnected by aponeuroses. A break in continuity may occur at the level of the aponeuroses, allowing part of the peritoneum to pass through and form a sac, known as a hernia, containing either fat or a portion of the intestine. Hernias or ventral ruptures (hernias occurring on a parietal surgical scar) are manifested by a protrusion on the surface of the skin and are called umbilical or inguinal hernias or ventral ruptures, for example, as a function of their location.

To repair a hernia, surgeons often fit a synthetic mesh prosthesis that replaces or reinforces the weakened anatomical tissue.

However, the efficacy of the prosthesis, and thus minimizing the risk of relapse, depend to a great degree on the proper fixing of the prosthesis. In particular, before being fixed, the prosthesis must be correctly spread over the abdominal wall that it is intended to reinforce. Prostheses of mesh type, i.e. based on an arrangement of threads forming a textile, are generally flexible, and to introduce them into the hernia they are often folded to reduce their volume. They therefore tend to form creases on the abdominal wall when they are introduced onto the implantation site. In this respect spreading them out is of primary importance but may prove difficult, in particular in the case of treating an umbilical hernia, which, being smaller than an inguinal hernia, offers little working space and little visibility for manipulation of the prosthesis by the surgeon.

In the case of umbilical hernias, for example, or when the aim of treatment is to repair trocar holes or preventive, the size of the defect to be treated is small, for example from 1 to 4 cm diameter, and open surgery may be envisaged without widening the defect. However, in this type of surgery, the surgeon has little working space and little visibility. It would thus be preferable to have a prosthesis that is easy to position, to spread out and to fix, if possible avoiding the necessity for sutures at the periphery of the prosthesis, which is complicated and laborious under such working conditions.

Failure to spread the prosthesis out perfectly against the abdominal wall leads to the risk of trapping the peritoneal sac and the risk of insertion of a soft organ between the prosthesis and the abdominal wall, which can lead to the risk of adhesions, pain and intestinal blockage and increase the possibility of relapse. It is therefore essential for the surgeon to be sure that no part of the prosthesis remains folded and that no viscera or any part of the intestines lie between the prosthesis and the abdominal wall. Moreover, incorrect positioning of the sutures or incorrect fixing of the prosthesis risks distortion of the prosthesis and the creation of tensions.

Thus in the case of an umbilical hernia in particular, having a small orifice for introducing the prosthesis, it would be beneficial to have a prosthesis adapted to occupy a small volume in a first configuration in order to facilitate its introduction into the abdominal cavity via said orifice and then to be deployed, spread out and pressed easily against the abdominal wall so that the surgeon is sure of the optimal positioning of the prosthesis and can moreover fix the prosthesis efficaciously without sutures at its periphery, and this, despite the little intrinsic visibility of small size hernias.

Various prostheses that may be folded up and then deployed are available.

The present invention concerns a prosthesis that is adapted to be folded up in order to reduce the volume that it occupies at the time of its introduction into a small incision and on the other hand to be spread out and fixed easily so that the surgeon is sure of the perfect spreading of the prosthesis and that it may be fixed efficaciously at a certain distance between the centre of the prosthesis and its periphery without sutures at the periphery of the prosthesis and this, despite the little intrinsic visibility of small size hernias.

The prosthesis of the invention is beneficial for treating hernias of the abdominal wall, in particular for treating umbilical hernias where the defect is small.

A first aspect of the present invention provides a prosthesis comprising:

at least one flexible mesh delimited by a peripheral exterior edge,

at least one member for reinforcing said mesh, said reinforcing member taking the form of a frame fastened to said mesh and substantially adopting the shape of said peripheral exterior edge of the mesh, said frame being set back from said peripheral exterior edge and being provided with two hinge points, the line passing through said two hinge points also passing through the centre of the mesh and thus forming a line M for folding the mesh in two,

characterized in that said prosthesis further comprises at least two anchor pieces made of suturable material and located on a single face of the mesh on either side of said folding line, each piece having a fixed part linked to said mesh and a free part, said free part being linked to at least one thread-shaped element.

The reinforcing member or frame may be rigid or have some flexibility. According to the present invention, the mesh and thus the prosthesis can be folded in two because of the presence of the two hinge points of the frame, regardless of the presence or not of intrinsic elastic properties of the frame.

In the context of the present application the term "mesh" refers to an arrangement of biocompatible threads, for example a knitted, woven or non-woven material, preferably of the openwork kind, i.e. having pores encouraging tissue recolonization. Such a mesh may be bioresorbable, partly bioresorbable or permanent. It is sufficiently flexible to be folded up at the time of its introduction into the abdominal cavity. The mesh may be produced from one layer of textile or from a plurality of layers of textiles. Such meshes are well known to the person skilled in the art. The mesh usable for the invention may be supplied in any shape (rectangular, square, circular, oval, etc.) and then cut to match the shape of the hernia defect. For example, the mesh may have the overall shape of a disc or an oval: in this case the frame also has a circular or oval shape and is preferably in the form of a ring. Alternatively, the mesh may have a globally square or rectangular shape: in this case the frame also has a square or rectangular shape. The frame is set back from the exterior peripheral edge of the mesh: thus, whilst adopting the shape of the contour of the mesh, the frame has an exterior perimeter smaller than that of the exterior peripheral edge of the mesh: in other words, the exterior peripheral edge of the mesh extends a certain distance beyond the frame. This distance may be greater than or equal to 1 mm, for example. In other words also, the frame and the exterior peripheral edge of the mesh are of similar geometric shape but the frame shows dimensions which are less than that of the exterior peripheral edge of the mesh.

As will become apparent from the following description, the shape of the frame and its location, set back slightly from

3

the exterior peripheral edge of the mesh, enable the surgeon, when implanting the prosthesis, to fix it to the peritoneum efficaciously without requiring sutures at the periphery of the mesh: the surgeon is able to fix the prosthesis along the interior contour of the frame only, said interior contour 5 defining a stitches fixing line: this avoids the surgeon having to apply stitches to the prosthesis at the exterior peripheral edge of the mesh, which is difficult to reach and hardly visible because of the small size of the incision. The interior contour of the frame of the prosthesis of the invention defines a fixing line, or stitching line, located approximately 10 half way between the centre of the mesh and its exterior peripheral edge, along which the surgeon may locate the stitches when he fixes the prosthesis to the abdominal wall. Nevertheless, perfect spreading out of the prosthesis is 15 assured by the presence of the frame which, by adopting the shape of the contour of the exterior peripheral edge, ensures deployment of the prosthesis and pressing thereof onto the abdominal wall.

In the context of the present application, by “anchor piece made of suturable material” is meant that the anchor piece is capable of being linked to, or passed through by, a thread-shaped element as defined in the present application, without being torn off when a user, such as a surgeon for example, exerts a moderate tension on said thread-shaped 20 element, such as the necessary tension for orientating and/or positioning the prosthesis in the implantation site, as described hereinafter. Thus the anchor piece may be under the form of a textile, either knitted, woven or nonwoven, open worked or not; alternatively or in addition, the anchor 25 piece may be under the form of a film or a sheet of material, as long as this textile, film and/or sheet of material is not torn off under the effect of the moderate tension as described above exerted on a thread-shaped element linked to, or passing through, said textile, film and/or sheet.

The anchor pieces may be made of bioresorbable material or not. The bioresorbable material may be chosen, for example, from polylactic acid (PLA), polycaprolactone (PCL), polydioxanone (PDO), trimethylene carbonate (TMC), polyvinyl alcohol (PVA), polyhydroxyalkanoate 30 (PHA), oxidized cellulose, polyglycol acid (PGA), copolymers of these materials and mixtures thereof.

As will be apparent from the following description, the anchor pieces are useful to the surgeon for facilitating the positioning of the prosthesis in the centre of the defect to be 35 treated, and for attaching the prosthesis to the biological tissues. The anchor pieces also form the parts of the prosthesis by which said prosthesis is sutured to the abdominal wall.

The anchor pieces of the prosthesis of the invention are located on one single face of the mesh: as will be apparent from the following description, the anchor pieces are located on the face of the mesh intended to face the abdominal wall once the prosthesis is implanted: indeed, said anchor pieces are intended to be reached by the surgeon through the 40 incision made for the implantation, in particular by means of thread-shaped elements, in view of assisting the surgeon to orientate and position the prosthesis as well as to raise the edges of the hernia defect for visualising the area to be stitched, when the prosthesis is put in place. The prosthesis of the invention thus comprises at least two anchor pieces 45 located on either side of the folding line, preferably at two places which are symmetrical to each other with respect to this folding line: such a location of the anchor pieces enables the surgeon to expand the prosthesis optimally when it is put in place. According to the invention, the number of anchor 50 pieces is not limited and the prosthesis may comprise 3 or 4

4

anchor pieces, even more. Each anchor piece shows a fixed part linked to the mesh of the prosthesis, and a free part, not attached to the mesh, and forming a type of shutter, flap or flying part. The fixed part of the anchor piece may be linked 5 to the mesh by gluing, welding, sewing or by any biocompatible fixing means. In one embodiment, the anchor pieces are linked to the mesh via their fixed part by means of the reinforcing member.

The anchor pieces may show any geometrical shape. They may be identical or different.

In one embodiment, each anchor piece having a geometrical shape with at least one side having a length equal or greater than that of the other sides, each anchor piece is linked to the mesh by its longest side, along a direction 10 perpendicular to the segment linking the centre of the mesh and the point of fixation of said piece in the plane of the mesh. In such an embodiment, each anchor piece being linked to the mesh by its longest side, the free part, or shutter or flap of each piece occupies only little space in the surroundings of the mesh: this enables maintaining a clear and non obstructed space around the hernia defect when the prosthesis is put in place and therefore allows the surgeon having a good visibility of the implantation site and not 15 being impeded by the presence of useless extra elements. Such an embodiment also enables a more secure fixation of the anchor pieces to the mesh. Moreover, the positioning of the anchor pieces, i.e. along a direction perpendicular to the segment linking the centre of the mesh and the point of fixation of said piece in the plane of the mesh, allows the 20 surgeon to position the prosthesis optimally by pulling on the thread-shaped elements linked to the anchor pieces in a centrifugal direction with respect to the hernia defect, as will be apparent in the following description.

In one embodiment, the suturable material is a textile and the anchor pieces are textile pieces. This textile may be identical to that of the mesh, or different. For example, the anchor pieces may be sewn to the mesh.

In the context of the present application, by “thread-shaped element”, is meant a flexible and elongated element, the length of which is much more greater than its thickness and its width, the contour of the cross section of which is globally circular: examples of thread-shaped elements of the invention may be a thread on its own, composite or not, or several threads, for example arranged together to make a braid, a tube, and combinations thereof. In embodiments, the 35 thread-shaped elements are selected from threads, flexible tubes and combinations thereof.

In the prosthesis of the invention, the free part of each anchor piece is linked to at least one thread-shaped element. As will be apparent from the detailed description below, the thread-shaped element is intended to allow the surgeon to pull on the anchor piece linked thereto in order to expand, orientate and position the prosthesis when said prosthesis is put in place: preferably, the surgeon will pull simultaneously 40 on the thread-shaped elements of the at least two anchor pieces which are present in order to counterbalance the prosthesis with respect to the defect to be treated. In addition, due to its structure, the thread-shaped element does not unnecessarily encumber the working area for the surgeon, said area being already naturally particularly limited regarding small size hernias.

In embodiments, the thread-shaped elements are flexible tubes: because of their hollow structure, necessitating a certain outer diameter, for example equal or greater than 3 45 mm, the tubes show a quite important outer surface capable of being in contact with the margins of the defect, this allowing decreasing dramatically the potential traumatic

5

effect due to the contact of the tubes with the margins of the defect. The flexibility of the tubes allows their easy handling with no risk of damaging the tissues. Preferably, the tubes are flexible and semi-rigid. As will appear from the following description, such a semi-rigidity of the tubes allows maintaining the anchor pieces to which they are linked under slight tension, without having to apply any particular tension on these tubes. The flexible tubes may be in plastic material, silicone, or a combination of these materials.

In one embodiment of the invention, the mesh of the prosthesis of the invention is a knitted fabric: because of the stitches that form it, a knitted fabric makes it possible to obtain openwork faces encouraging cellular recolonization after implantation. The knitted fabric may be a two-dimensional knitted fabric or a three-dimensional knitted fabric.

In the context of the present application, the expression "two-dimensional knitted fabric" means a knitted fabric having two opposite faces linked together by stitches but having no spacers imparting a certain thickness to it: such a knitted fabric may be obtained, for example, by knitting threads on a warp or Raschel knitting machine using two guide bars. Examples of two-dimensional knitted fabrics suitable for the present invention are given in the document WO2009/071998.

In the present application, the expression "three-dimensional knitted fabric" means a knitted fabric having two opposite faces linked together by spacers imparting a significant thickness to the knitted fabric, said spacers consisting of connecting threads additional to the threads forming the two faces of the knitted fabric. Such a knitted fabric may be obtained, for example, using a double-bed Raschel knitting machine or warp knitting machine with a plurality of guide bars. Examples of knitting three-dimensional knitted fabrics suitable for the present invention are given in the documents WO99/05990, WO2009/031035, WO2009/071998.

In one embodiment, said frame is set back from the exterior peripheral edge of the mesh and is of serpentine shape, forming undulations. For example, said frame is in the form of a flat ribbon forming undulations substantially in the plane of said mesh. As will become apparent from the description given hereinafter, this configuration of the frame makes it possible, when fixing the prosthesis to the biological tissue, to execute a suture in the prosthesis at a given location without deforming the prosthesis as a whole during this operation; deformation of the prosthesis caused by the suture at the given location is smoothed out by the undulating frame. Thus the frame and therefore the rest of the prosthesis remain correctly positioned, and in particular remain pressed against the abdominal wall, during the fixing of the prosthesis.

In one embodiment, said reinforcing member is produced in bioresorbable material. Thus the reinforcing member fulfils its role of stiffening the prosthesis during positioning and implantation of the prosthesis and is then degraded progressively once the mesh is recolonized by the surrounding cells.

The bioresorbable material may be chosen, for example, from polylactic acid (PLA), polycaprolactone (PCL), polydioxanone (PDO), trimethylene carbonate (TMC), polyvinyl alcohol (PVA), polyhydroxyalkanoate (PHA), oxidized cellulose, polyglycol acid (PGA), copolymers of these materials and mixtures thereof.

Alternatively, the reinforcing member is produced in a non-bioresorbable material chosen from polypropylene, a polyester such as polyethylene terephthalate, polyamide,

6

silicone, polyetheretherketone (PEEK), polyaryletheretherketone (PAEK) and mixtures thereof.

In another embodiment, said reinforcing member is produced from a combination of bioresorbable material and non-bioresorbable material.

In one embodiment of the invention said mesh has the shape of a disc, said frame being substantially in the form of a circular ring. In such an embodiment, said anchor pieces may be fixed to two diametrically opposed places of an inner perimeter of said ring, said two places being spaced by 90° from each of said two hinge points. Such an embodiment enables an optimal deployment of the prosthesis by pulling in opposite directions on the respective thread-shaped elements of the two anchor pieces after the folded prosthesis has been introduced in the implantation site.

Alternatively, the prosthesis comprises four said anchor pieces distributed substantially regularly along an inner perimeter of said ring so that two anchor pieces are located on one side of the folding line and the other two anchor pieces are located on the other side of said folding line. In such an embodiment, for example, a single thread-shaped element links together the free parts of two anchor pieces located on the same side of the folding line. The total number of thread-shaped elements thus remains low and the surgeon is not impeded by the presence of extra thread-shaped elements. Moreover, the deployment and orientation step of the prosthesis is rendered easier: indeed, each thread-shaped element, because it links together the free parts of two anchor pieces located on the same side of the folding line, forms a sort of loop that the surgeon may very easily grasp and handle, in particular in view of exerting a tension on this loop: in addition, such a tension enables pulling on two anchor pieces simultaneously, at two different places of the mesh, thereby allowing optimised deployment and spreading out of the mesh and of the prosthesis.

Alternatively, a single thread-shaped element may link together the free parts of two adjacent anchor pieces located on each side of the folding line.

In embodiments, the anchor pieces have a colour different than that of the mesh. Alternatively or in addition, the thread-shaped elements have a colour different than that of the mesh and than that of the anchor pieces. Thanks to the present invention, the surgeon works in a relative non obstructed implantation site where he can see the area of the prosthesis to be attached to the abdominal wall, this area being located more or less in the middle between the centre of the mesh and the edge of the mesh: such embodiments of the prosthesis of the invention allow the surgeon to easily and rapidly make the necessary stitches by enabling him, thanks to the different colours, to quickly identify whether he handles the mesh, the anchor pieces or the thread-shaped elements.

In one embodiment of the invention, the face of the mesh opposite that including said anchor pieces is covered with a non-adherent coating.

Such a coating makes it possible in particular to avoid the formation of unwanted severe post-operative fibrous adhesions.

In the context of the present application the expression "non-adherent" refers to a non-porous, smooth, biocompatible coating or material offering no space for cellular recolonization and preferably encouraging the birth of a peritoneum.

In embodiments, where the prosthesis comprises four said anchor pieces distributed substantially regularly along an inner perimeter of said ring so that two anchor pieces are located on one side of the folding line and the other two

anchor pieces are located on the other side of said folding line, all four anchor pieces are under the form of isosceles triangles of textile, each triangle being fixed to said mesh via its base, all four triangles showing identical elongation and tensile strength properties in the centripetal direction.

For example, each isosceles triangle is fixed to the mesh via its base by means of the ring, the thread-shaped element being attached to the vertex angle of the isosceles triangle. Because of the four isosceles triangles of textile having the same mechanical properties in the centripetal direction, when the surgeon pulls on the thread-shaped elements at the time he puts the prosthesis in place and fixes it to the abdominal wall, all anchor pieces react similarly and the traction exerted by the surgeon on the whole prosthesis via the thread-shaped elements is regularly distributed. The prosthesis is therefore properly positioned. In addition, in embodiments where the four isosceles triangles of textile have a colour different from that of the mesh, the surgeon readily identifies the stitching line as defined above and the step of fixing the prosthesis to the abdominal wall is facilitated. As will appear from the description below, the method of manufacturing a prosthesis with four anchor pieces under the form of four isosceles triangle of textile having identical mechanical properties is simple and easy.

The present invention will emerge more clearly from the description given hereinafter and from the appended drawings, in which:

FIG. 1 is a representation in section of a median abdominal hernia or ventral rupture,

FIG. 2 is a simplified view of the hernia from FIG. 1 after the surgeon has made an abdominal incision and removed the hernia sac,

FIG. 3 is a top view of one embodiment of a mesh for a prosthesis of the invention,

FIG. 4 is a top view of a reinforcing member for the prosthesis of the invention,

FIGS. 5A to 5D are views of anchor pieces of the prosthesis of the invention,

FIG. 6 is a top view of a first embodiment of the prosthesis of the invention,

FIG. 7 is a top view of another embodiment of the prosthesis of the invention,

FIG. 8 is a top view of another embodiment of the prosthesis of the invention,

FIG. 9 is a top view of another embodiment of the prosthesis of the invention,

FIG. 10 is a simplified sectional view of the introduction of the prosthesis from FIG. 8 into the hernia defect,

FIG. 11 is a simplified sectional view of the positioning of the prosthesis from FIG. 8 after deployment thereof at the implantation site,

FIG. 12 is a simplified sectional view of the fixing of the prosthesis from FIG. 8 to the abdominal wall,

FIG. 13 is a view in section of the prosthesis from FIG. 8 when fixed to the biological tissues just before closure of the abdominal incision by the surgeon,

FIG. 14-17 are top views showing the successive steps of the manufacturing process of a prosthesis of the invention comprising four anchor pieces of textile of identical mechanical properties.

FIG. 1 represents a hernia defect 100 of the abdominal wall 101 that is characterized by a break in the continuity of the aponeurosis 102 surrounding the straight muscles 103 and a passage through the peritoneum 104 forming a sac, the hernia sac 105, that contains either fat (epiploon) or part of the viscera 106, and which then presses on the fatty tissues

107 and is flush with the skin 108. One treatment of a hernia defect 100 entails replacing and retaining the viscera 106 in the abdominal cavity 109.

FIG. 2 shows the hernia defect 100 from FIG. 1 after the surgeon has made an incision in the skin 108, the abdominal wall 101 and the peritoneum 104 and has reduced the hernia sac. The viscera are not shown in FIG. 2: they have been pushed back into the abdominal cavity 109. The surgeon must now introduce into the abdominal cavity 109, via the incision 110 that has been made, a prosthesis for reinforcing the abdominal wall, before closing the incision 110 by means of sutures, for example. In the case of an umbilical hernia, the size of the incision 110 is particularly small, for example of the order of 1 to 4 cm diameter.

FIG. 3 represents a mesh 1 in the form of a disc usable with the reinforcing member from FIG. 4 and anchor pieces such as that from FIGS. 5A to 5D to produce a prosthesis of the invention.

The mesh 1 is made from a knitted, woven or non-woven arrangement of biocompatible threads. It may be bioresorbable, partly bioresorbable or permanent. The mesh is generally openwork, incorporating pores for better tissue integration. This mesh 1 is sufficiently flexible to be folded when the prosthesis is introduced into the abdominal cavity 109 via the incision 110. However, the mesh is generally a textile having no elasticity enabling it to return to a spread out configuration of its own accord after it has been folded up. The mesh 1 may be produced from a textile layer or a plurality of textile layers. The textile may be a two-dimensional or three-dimensional knitted fabric. Such meshes are well known to the person skilled in the art and are not described in more detail here. The mesh may be supplied in the form of a strip that is cut to the dimensions of the defect to be treated. In the example represented, the mesh 1 has the shape of a disc adapted to the shape of the incision 110 at the hernia defect 100 and delimited by an exterior peripheral edge 1a. In other embodiments, the mesh may be of oval shape. Alternatively, the mesh may be of rectangular or square shape.

FIG. 4 represents a reinforcing member of a prosthesis of the invention, suitable for the shape of the mesh 1 from FIG. 3: as is apparent from FIG. 4 and FIG. 6, the reinforcing member takes the form of a frame 2 substantially adopting the shape of the exterior peripheral edge 1a of the mesh 1. Thus the overall shape of the frame 2 is a circular ring. The frame 2 is provided with two hinge points 3a and 3b that are diametrically opposite in the example shown. The two hinge points (3a, 3b) make it possible to fold the frame 2, for example when force is applied by the surgeon, resulting in two globally identical parts. The hinge points (3a, 3b) preferably do not have any elasticity of their own: thus, once folded in two, the frame 2 can be unfolded only by the action of an external force, for example exerted by the surgeon.

The frame 2 thus consists of two parts, namely two semicircles 2a and 2b, connected together by two hinge points (3a, 3b). As seen in FIG. 4, the respective ends (2c; 2d) of the semicircles 2a and 2b are blunted or rounded to prevent trauma when implanting the prosthesis. In the example shown, the two semicircles 2a and 2b are symmetrical: the two hinge points (3a; 3b) define a median line M passing through the centre of the circle delimited by the frame and also through the centre of the mesh 1 when the frame 2 is fixed to the mesh 1, as shown in FIG. 6. Thus the mesh 1 may be folded in two even when fitted with the frame 2: consequently, as will become apparent in the remainder of the description, the prosthesis may be folded. Similarly, given the configuration of the frame 2 in two parts and the

absence of any elasticity of the frame **2** and its hinge points (**3a**, **3b**), the prosthesis is able to adopt only two configurations: either a flat and spread out configuration or a folded in two configuration. As explained later, the fact that the prosthesis can adopt only two configurations facilitates the task of the surgeon, who can immediately determine if the prosthesis is in its spread out configuration or not.

As seen in FIGS. **4** and **6**, the frame **2** is an undulating ring set back from the exterior peripheral edge **1a**, consisting of undulations **4**. Referring to FIG. **6** in particular, the exterior peripheral edge **1a** of the mesh extends some distance beyond the exterior contour of the frame **2**: this distance may be greater than or equal to 1 mm, for example. As will become apparent from the description given hereinafter, the location of the frame **2**, slightly set back from the exterior peripheral edge **1a**, facilitates efficacious fixing of the prosthesis to the abdominal wall, in particular in an area located more or less half way between the centre and the edge of the mesh, this area being adjacent to the interior contour of the frame **2**.

The undulations **4** of the frame **2** may be regular or not. In particular, in the example shown, the frame **2** is in the form of a flat ribbon of material forming undulations **4** in the plane of the frame **2**, which is substantially the plane of the prosthesis. As will become apparent in the remainder of the description, such a shape imparts to the frame **2** great flexibility in the plane of the frame **2** and thus in the plane of the prosthesis: it is thus possible to suture part of the prosthesis at a given place, without rocking or deforming the prosthesis as a whole: the deformation created at the location of the suture is smoothed out by the undulations **4** of the frame **2** over the whole of the periphery of the prosthesis. In addition, the frame **2** shows a rigidity along its section, so that it neither deforms radially in the outward nor in the inward directions.

Materials suitable for producing the reinforcing member of the prosthesis of the invention may be any biocompatible materials having some rigidity so as to respond to the expectations disclosed above.

The frame **2** can thus be produced in any biocompatible material, bioresorbable or not. In a preferred embodiment, it is made in bioresorbable material. In the present application, the term "bioresorbable" refers to the characteristic whereby a material is absorbed by biological tissues and disappears in vivo after a given period, which may vary from one day to several months, for example, depending on the chemical nature of the material.

Bioresorbable materials suitable for the fabrication of the reinforcing member of the prosthesis of the present invention include polylactic acid (PLA), polycaprolactone (PCL), polydioxanone (PDO), trimethylene carbonate (TMC), polyvinyl alcohol (PVA), polyhydroxyalkanoate (PHA), oxidized cellulose, polyglycolic acid (PGA), copolymers of these materials and mixtures thereof. Bioresorbable materials suitable for the fabrication of the reinforcing member of the prosthesis of the invention include polyester (glycolid, dioxanone, trimethylene carbonate) available from the company Covidien under the trade name "BIOSYN®" and polyester (glycolid, caprolactone, trimethylene carbonate, lactid) available commercially from the company Covidien under the trade name "CAPROSYN®".

Non-bioresorbable materials suitable for the fabrication of the reinforcing member of the prosthesis of the present invention include polypropylene, polyesters such as polyethylene terephthalate, polyamide, silicone, polyetheretherketone (PEEK), polyaryletheretherketone (PAEK) and mixtures thereof.

Each part of the reinforcing member of the prosthesis of the invention may be made in one piece, for example, by injection moulding one or more biocompatible thermoplastic or thermosetting materials. The hinge points (**3a**, **3b**) of the frame **2** may be produced in the same material as the rest of the frame: these hinge points (**3a**, **3b**) take the form for example of very thin bridges of material in order to enable folding of the frame **2** without causing separation of the two parts joined together by these bridges.

With reference to FIGS. **5A** to **5D** are shown, on their own, examples of anchor pieces **5** suitable for the prosthesis of the invention, each provided with a thread-shaped element (**6**, **7**). The anchor pieces may show any geometrical shape, for example triangular, squared, semicircular. They may be identical or different for a single prosthesis.

In embodiments, such as those shown on FIGS. **5A** to **5B**, the anchor pieces **5** show a geometrical shape where at least one side has a length greater than or equal to that of the other sides. Thus, with reference to FIG. **5A**, the anchor piece **5** has the shape of a triangle. In this example, the triangle is isosceles and the basis **B** of the triangle is the side having the greatest length. As will appear hereinafter, the longest side of the anchor piece **5** will form the fixed part **5a** of the anchor piece **5** while the area located around the summit **C** opposed to that basis **B** will form the free part **5b** of the anchor piece **5**. In the same way, with reference to FIG. **5B**, the anchor piece **5** having globally the shape of a semi-disc, the diameter **D** forms the side of greater length of the anchor piece and will therefore form the fixed part **5a** of the anchor piece, while the rounded part forms the free part **5b** of the anchor piece **5**. With reference to FIG. **5C**, the anchor piece has globally the shape of an isosceles triangle the basis of which is an arc of circle: this basis will form the fixed part **5a** of the anchor piece, while the area located around the summit opposed to that arc of circle will form the free part **5b** of the anchor piece **5**.

On FIG. **5D** is shown an anchor piece **5** of trapezoid shape, the parallel sides of which show an arc of circle shape: the longest arc of circle forms the fixed part **5a** of the anchor piece, while the area located around the shortest arc of circle forms the free part **5b** of the anchor piece.

On FIGS. **5A** to **5B**, the free part **5b** of each anchor piece is linked to a thread-shaped element. In the context of the present application, by "thread-shaped element", is meant a flexible and elongated element, the length of which is much more greater than its thickness and its width, the contour of the cross section of which is globally circular: examples of thread-shaped elements of the invention may be a thread on its own, composite or not, or several threads, for example arranged together to make a braid, a tube, and combinations thereof. In embodiments, the thread-shaped elements are selected from threads, tubes and combinations thereof.

As will be apparent from the following detailed description, the thread-shaped element is intended to allow the surgeon to pull on the anchor piece linked thereto in order to expand, orientate and position the prosthesis when said prosthesis is put in place: preferably, the surgeon will pull simultaneously on the thread-shaped elements of the at least two anchor pieces which are present in order to centre and counterbalance the prosthesis with respect to the defect to be treated.

With reference to FIG. **5A**, the free part **5b** of the anchor piece is linked to a thread **6** passing through said free part **5b**. On the example shown, the thread **6** forms a loop. Alternatively, the thread **6** may be attached by one of its ends to the free part **5b** of the anchor piece **5**. With reference to FIG. **5B**, the free part **5b** of the anchor piece is also linked to a thread

6 passing through said free part **5b**, said thread **6** forming a loop at the location of said free part **5b**, the two strands of the loop being further brought together within a tube **7**.

With reference to FIG. **5C**, the free part **5b** of the anchor piece **5** is linked to a tube **7**: on the example shown, the two ends **7a** and **7b** of tube **7** are attached to the free part **5b** and the tube **7** forms a loop. With reference to FIG. **5D**, the free part **5b** of the anchor piece **5** is linked to one end **7a** of a tube **7**.

The tube **7** is flexible and, because of its hollow structure, necessitating a certain outer diameter, for example equal to or greater than 3 mm, it shows a quite important outer surface capable of being in contact with the margins of the defect, this allowing decreasing dramatically the potential traumatic effect due to the contact of the tube **7** with the margins of the defect. The flexible tube **7** may be in plastic material, silicone, or in a combination of these materials.

The anchor pieces **5** of the prosthesis of the invention are made of a suturable material: in the context of the present application, it is hereby meant that the anchor piece **5** is capable of being linked to, or passed through by, a thread-shaped element, such as a thread **6** or a tube **7**, without being torn off when a user, such as a surgeon for example, exerts a moderate tension on said thread-shaped element, such as the necessary tension for orientating and/or positioning the prosthesis in the implantation site, as described hereinafter. The anchor pieces **5** may be made of any biocompatible suturable material giving them the necessary flexibility for being grasped by the surgeon when the prosthesis is put in place, as will be described hereinafter.

The anchor piece **5** may be under the form of a textile, either knitted, woven or nonwoven, open worked or not; alternatively or in addition, the anchor piece may be under the form of a film or a sheet of material, as long as this textile, film and/or sheet of material is not torn off under the effect of the moderate tension as described above exerted on a thread-shaped element linked to, or passing through, said textile, film and/or sheet.

As will be apparent from the following description, the anchor pieces are useful to the surgeon for facilitating the positioning of the prosthesis in the centre of the defect to be treated, and for attaching the prosthesis to the biological tissues. The anchor pieces also form the parts of the prosthesis by which said prosthesis is sutured to the abdominal wall.

With reference to FIG. **6** is shown a prosthesis **200** according to the invention, comprising the mesh **1** of FIG. **3**, the reinforcing member **2** of FIG. **4** and two anchor pieces **5** similar to the anchor piece of FIG. **5C**, each anchor piece **5** being on that FIG. **6** linked to a thread-shaped element under the form of a thread **6**.

As is apparent from this FIG. **6**, the anchor pieces **5** are each attached to the mesh **1** by their longer side forming the fixed part **5a** of the anchor piece: the fixing of each anchor piece **5** by its longer side allows a more reliable fixation. Moreover, the fixed part **5a** of each anchor piece **5** is attached along the direction of the line **P** which is perpendicular to the segment **S** linking the centre of the mesh and the point of fixation of each piece in the plane of the mesh. The fixed part **5a** or longer side of each anchor piece is fixed to the mesh for example by sewing. Alternatively, it may be fixed to the mesh **1** by gluing, welding or by means of the reinforcing member **2**.

The anchor pieces **5** being fixed to the mesh by their longest side, they do not impede the surgeon at the time of the prosthesis is implanted. On FIG. **6**, the two anchor pieces **5** are fixed to two diametrically opposed places of an inner

perimeter of the ring **2**, said two places being spaced by 90° from each of said two hinge points (**3a**, **3b**).

With reference to FIGS. **7** to **9** are shown prosthesis **200** of the invention made with the mesh **1** from FIG. **3**, the frame **2** from FIG. **4** and four anchor pieces **5** from FIG. **5A**, linked to various thread-shaped elements.

In these embodiments, the four anchor pieces **5** are arranged regularly along an inner perimeter of the ring formed by the frame **2** so that two anchor pieces **5** are located on one side of the folding line **M** and the two other anchor pieces are located on the other side of the folding line **M**: the four anchor pieces therefore counterbalance one another. Each anchor piece **5** is fixed to the mesh **1** by its fixed part **5a**, the free parts **5b** being left flying and forming flaps. For example, each fixed part **5a** is attached to the mesh **1** by a seaming **8**. Moreover, a single thread-shaped element (**6**, **7**) links together the free parts **5b** of two anchor pieces **5** located on the same side of the folding line **M**.

With reference to FIG. **7**, the thread-shaped element is under the form of a combination of a thread **6** and a tube **7**: the thread **6** forms a loop at the place of the free part **5b** of the anchor piece it is linked to, the two strands of the loop being brought together within a tube **7** at the place of grasping of the thread-shaped element by the surgeon. Such an embodiment allows an easier and more comfortable grasping of the thread-shaped element by the surgeon.

With reference to FIG. **8**, the thread-shaped element is under the form of a tube **7**: the single end **7a** of the tube **7** is attached to the free part of a first anchor piece **5** while the second end **7b** of the same tube **7** is attached to the free part **5b** of the adjacent anchor piece located on the same side of the folding line **M** as the first anchor piece **5**. Such an embodiment, in which the thread-shaped element is a tube **7**, allows an easier and more comfortable grasping of the thread-shaped element, while limiting the risk of trauma when the thread-shaped element contacts the margins of the defect to be treated at the time of positioning the prosthesis **200**. The tube **7** may itself contain one or several threads.

With reference to FIG. **9**, the thread-shaped element is under the form of a thread **6** forming a loop at the place of the free part **5b** of a first anchor piece **5** and at the place of the free part **5b** of an adjacent anchor piece located on the same side of the folding line **M** as the first anchor piece **5**.

The presence of the four anchor pieces **5**, regularly distributed as described above in FIGS. **7** to **10**, and of the thread-shaped elements linking anchor pieces **5** by pairs enables the surgeon to optimally spread out the prosthesis **200** on the implantation site and to balance the tension between the various anchor pieces **5** at the time of positioning the prosthesis **200** and to centre the latter prosthesis better relative to the defect to be closed.

In one embodiment of the prosthesis **200** not shown, the reinforcing member, namely the frame **2**, is welded directly to the mesh **1** and to the fixed parts **5a** of anchor pieces **5**. Thus the frame **2** is fastened both to the mesh **1** and to the anchor pieces **5**.

In the FIG. **8** embodiment, the face of the mesh **1** opposite that including the anchor pieces **5** is covered by a non-adherent coating **201**. Such a non-adherent coating makes it possible to avoid in particular the formation of unwanted severe post-operative fibrous adhesions; once the prosthesis **200** has been implanted, the face of the prosthesis **200** covered by the non-adherent coating **201** faces the abdominal cavity **109**.

The non-adherent coating or material is chosen from bioresorbable materials, non-bioresorbable materials and mixtures thereof. The non-bioresorbable non-adherent mate-

rials may be chosen from polytetrafluoroethylene, polyethylene glycol, polysiloxane, polyurethane, and mixtures thereof.

Said non-adherent coating or material is preferably bioresorbable: bioresorbable materials suitable for said non-adherent coating may be chosen from collagen, oxidized cellulose, polyacrylate, trimethylene carbonate, caprolactone, dioxanone, glycolic acid, lactic acid, glycolide, lactide, polysaccharide, for example chitosan, polyglucuronic acid, hyaluronic acid, dextran and mixtures thereof.

The non-adherent coating makes it possible to protect the mesh **1** of the prosthesis **200** at least during the initial scar formation phase, i.e. the mesh **1** is not exposed to inflammatory cells, such as granulocytes, monocytes, macrophages or the giant multinucleated cells generally activated by surgery. At least during the initial scar formation phase, the duration of which may vary from about 5 days to about 10 days, only the non-adherent coating is accessible to the various factors such as proteins, enzymes, cytokines or inflammatory cells.

If the non-adherent coating consists of non-resorbable materials, it thus protects the mesh **1** before and after implantation and throughout the duration of implantation of the prosthesis **200**.

Moreover, thanks to the non-adherent coating, surrounding fragile tissues, such as the hollow viscera, for example, are protected, in particular from unwanted severe post-operative fibrous adhesion.

If the non-adherent material includes a bioresorbable material, it is preferable to choose a bioresorbable material that is not resorbed in less than a few days in order for the non-adherent coating to be able to fulfil its function of protecting the intestine and hollow organs during the days following surgery until cellular rehabilitation of the prosthesis takes over protecting these fragile organs.

Because of its two-part reinforcing member, namely the frame **2** consisting of the two semicircles **2a** and **2b** in the example shown, connected together by hinge points **3a**, **3b**, the prosthesis **200** of the invention may adopt a folded configuration after the surgeon folds it along the folding line **M**. Thus to implant the prosthesis **200** the surgeon folds it in two so that it occupies a smaller volume, which facilitates introduction of the prosthesis into the hernia defect **100** (see FIG. **2**) by the surgeon.

The mesh **1** and the non-adherent coating **201** are sufficiently flexible to follow successive deformations of the prosthesis **200** as the latter is introduced to the implantation site.

FIGS. **14-17** describe various steps of a method for manufacturing an embodiment of a prosthesis **210** of the invention made with the mesh **1** of FIG. **3**, the frame **2** of FIG. **4** and four anchor pieces **215**. For clarity's sake, the thread-shaped elements are not shown on FIGS. **14-17**: these thread-shaped elements may be any one of FIGS. **6-9** and may be attached to said anchor pieces **215** as described above.

As will appear from the description below, the four anchor pieces **215** of prosthesis **210** are arranged symmetrically along the interior contour of the ring formed by the frame **2**, and they all have the same mechanical properties.

The manufacturing process of such embodiments will now be described with reference to FIGS. **14-17**.

With reference to FIG. **14**, is shown a textile **20** for forming the anchor pieces **215** of the prosthesis **210** (see FIG. **17**). On the example shown, the textile **20** has the shape of a square, the length of one side of the square being greater than the greater diameter of the intended resulting prosthesis

**210**. This textile **20** may be identical to that forming the mesh **1** or different. The textile **20** is for example produced on a knitting machine and has a warp direction **Wa** and a weft direction **We**, as shown on this FIG. **14**. The textile **20** may have different mechanical properties, such as elongation and tensile strength, along its warp direction **Wa** and along its weft direction **We**.

Preferably, the textile **20** has a colour different from that of the mesh **1**.

In order to proceed with the manufacturing of the four anchor pieces **215**, a cutting **21** having the shape of a cross with two perpendicular branches (**22**, **23**) is completed on textile **20**, with one branch **22** of the cross parallel to the warp direction **Wa** and the other branch **23** of the cross parallel to the weft direction **We**, as shown on FIG. **15**. The branches of the cross may be of identical lengths or not. On the example shown on FIG. **15**, the length of the branch **22** parallel to the warp direction **Wa** is smaller than the length of the branch **23** parallel to the weft direction. In addition, on this example and as will appear from FIG. **16**, the length of the branch **22** parallel to the warp direction **Wa** is smaller than the diameter of the internal perimeter of the frame **2**, whereas the length of the branch **23** parallel to the weft direction is greater than the diameter of the outer perimeter of the frame **2**.

In a further step, the textile **20** is laid upon a piece of mesh **1**, for example of similar square shape and dimensions as the textile **20**, and the frame **2** of FIG. **4** is then welded to both the mesh **1** and the textile **20**.

As shown on FIG. **16**, the frame **2** is welded on mesh **1** and textile **20** so that the greater branch **23** of the cutting **21** is applied on the folding line **M** defined by the frame **2** (see FIG. **4**) and extends beyond the hinge points (**3a**, **3b**) of the frame **2**, whereas the smaller branch **22** of the cutting **21** does not reach the frame **2**. Such an embodiment allows a better efficiency of the frame **2**, which may not be damaged by residual filaments coming from the cutting of branch **22** when said frame **2** is welded on both the mesh **1** and the textile **20**.

Once the frame **2** is welded, the disc-shape prosthesis **210** may be manufactured by cutting the mesh **1** and textile **20** in excess beyond the outer peripheral border of the frame **2**, as shown on FIG. **17**. As appears from this Figure, the frame **2** forms together with the cross-shaped cutting **21** four isosceles triangles **24**, more or less fixed to the frame **2** by their respective base **24a** and free at their vertex angle **24b**. These four isosceles triangles **24** of textile **20** form the anchor pieces **215** of the prosthesis **210**.

As mentioned above, a thread-shaped element (not shown) may then be attached to the free vertex angle **24b** of each triangle **24** by any fixation means such as those described above at FIGS. **6-9**, in line with the direction defined by the altitude **24c** drawn from the vertex angle **24b** of each triangle **24**.

Because of the specific cross-shaped cutting **21**, with one branch parallel to the warp direction **Wa** and the other branch parallel to the weft direction **We**, all four isosceles triangles **24** of textile **20** are identical and they all show the same mechanical properties, such as elongation properties and tensile strength properties, each in the direction of its altitude **24c** corresponding to the centripetal direction of the disc-shape prosthesis **210**, regardless from the fact that the initial elongation and tensile strength properties of the textile **20** in its warp direction **Wa** were identical or not to its initial elongation and tensile strength properties in the weft direction **We**.

15

Indeed, because of the location of the cutting **21** with respect to the frame **2** during the welding step, the altitude direction or centripetal direction for each triangle **24** forms an angle of 45° with respect to both warp and weft directions of the initial textile **20**.

As a consequence, all four anchor pieces **215** show the same mechanical properties, in particular elongation properties and tensile strength properties, in the direction corresponding to the direction of the altitude **24c** of each triangle **24**, in other words in the direction corresponding to the direction of the traction exerted by the surgeon when he pulls on the thread-shaped element (not shown) in order to put the prosthesis in place and to fix it to the abdominal wall.

As a consequence, when the surgeon pulls on the thread-shaped element at the time he puts the prosthesis **210** in place and fixes it to the abdominal wall, all anchor pieces **215** react similarly and the traction exerted by the surgeon on the whole prosthesis **210** via the four anchor pieces is equally distributed. The prosthesis **210** is therefore properly positioned. In addition, because the four isosceles triangles **24** of textile **20** have a colour different from that of the mesh **1**, the surgeon readily identifies the stitching line as defined above. The step of fixing the prosthesis **210** to the abdominal wall is therefore facilitated.

The method of manufacturing the prosthesis **210** described above is very simple and allows starting from a single piece of textile **20** for manufacturing the four anchor pieces **215**.

Alternatively, the prosthesis **210** may be manufactured by preparing initially four separate triangles **24** of textile **20** and welding each triangle **24** to the mesh **1** via the frame **2**, or alternatively by preparing two pieces of semi-discs of textile **20**, completing a perpendicular cutting on each semi-disc and welding the two cut semi-discs to the mesh via the frame **2**.

Like the prosthesis **200** of FIGS. 1-13, the prosthesis **210** of FIG. 17 may be coated on the face of the mesh **1** opposite that including the anchor pieces **215** with a non-adherent coating **201**.

The fitting of a prosthesis of the invention, for example the prosthesis **200** from FIG. 8, is described next with reference to FIGS. 10 to 13. Although not described, the fitting of the prosthesis **210** of FIG. 17 may be completed in the same manner as that described hereinafter for prosthesis **200** of FIG. 8.

After making the incision **110** described with reference to FIG. 2, the surgeon grasps the prosthesis **200** from FIG. 8, covered with a non-adherent coating **201** on the face of the mesh **1** opposite that including the anchor pieces **5**, and applies force to the prosthesis **200** with his fingers to fold it along the folding line **M**. Because of the presence of the two hinge points **3a** and **3b**, this operation is without difficulty and totally independent of the elastic or non-elastic nature of the frame **2**. In the embodiment shown, the prosthesis **200** being a disc, it is folded along one of its diameters, resulting in two identical parts. In this folded configuration, the prosthesis **200** occupies a small volume and the surgeon may easily introduce it into the abdominal cavity **109**, as shown in FIG. 10, while holding the thread-shaped elements, in other words the tubes **7** in the example shown, outside the body of the patient. Because of their structure, the thread-shaped elements allow limiting the volume of the various elements which need to be passed through the hernia defect. For clarity, the fingers of the surgeon are not represented in FIGS. 10 to 13.

Once the prosthesis **200** is in the abdominal cavity **109**, the surgeon releases the pressure on it. It is the surgeon who

16

manually deploys the prosthesis **200** in a perfectly tensioned and spread out configuration. Thus, the prosthesis **200** being able to adopt only two positions, namely folded in two or spread out, the surgeon is certain that the prosthesis is perfectly spread out from the moment of unfolding the prosthesis **200**.

In the next step, as shown in FIG. 11, the surgeon uses the thread-shaped elements, i.e. the tubes **7**, both to centre the prosthesis **200** relative to the incision **110** and to press the prosthesis **200** against the abdominal wall (**101**, **104**). To this end, the surgeon pulls the tubes **7** toward the exterior of the body of the patient and in opposite directions. The surface of the tubes **7** capable of being in contact with the margins of the defect being quite important, the risk of trauma is low. Moreover, the distribution of the anchor pieces **5** as explained above allows balancing and centering the prosthesis **200** on the defect to be treated while pressing said prosthesis on the abdominal wall. Thus the prosthesis **200** is spread perfectly and there is no risk of the viscera being disposed between the anchor pieces **5** and the abdominal wall (**101**, **104**).

Once the prosthesis **200** is correctly positioned relative to the hernia defect, the surgeon raises a part of the edge of the hernia with the help of the tubes **7** and thus uncovers a central area **12** in the vicinity of the prosthesis **200**, delimited overall by the anchor pieces **5**, which area the surgeon may easily view and in which the surgeon is able to work easily.

In an embodiment, the tubes **7** are flexible and semi-rigid. Such a semi-rigidity of the tubes **7** allows maintaining the anchor pieces **5** to which they are linked under slight tension, without having to apply any particular tension on these tubes: as such, once the surgeon has raised the edges of the hernia defect by pulling on the flexible and semi-rigid tubes **7** in order to uncover a working area, he can release the tension on the tubes **7**: the anchor pieces **5** remain under slight tension and maintain the edges of the defect in a raised position.

In embodiments, the anchor pieces **5** are of a colour different than that of the mesh **1**: indeed, because the fixation area of the prosthesis **200** to the abdominal wall (**101**, **104**) is located more or less in the middle between the centre **1b** of the mesh **1** and the edge of the mesh, the surgeon can differentiate the different colours between the various elements forming the prosthesis **200** and thus easily identify the anchor pieces **5** he has to suture: such a thing is not possible with the prosthesis of the prior art intended to be fixed to the abdominal wall at their periphery. In particular, the colour difference between the anchor pieces **5** and the mesh **1** defines a line, said line pointing out to the surgeon where to complete the stitches for fixing the prosthesis **200** to the abdominal wall. This fixing line, or stitching line, globally corresponds to the interior contour of the frame **2**. Also, for the same reasons, the thread-shaped elements, like the tubes **7**, may be of a colour different from that of the mesh and from that of the anchor pieces **5**.

In a following step, as shown in FIG. 12, the surgeon proceeds to fix the prosthesis **200** to the biological tissues by using a needle **9** and a suture **10** to suture the free part **5b** of each anchor piece **5** to the abdominal wall **101**, **104** within the central working area **12**. During this step, the whole of the prosthesis **200** remains perfectly spread out and perfectly pressed onto the abdominal wall **104**, notably by virtue of the presence of the undulations **4** of the frame **2**, which smooth out deformations caused by the surgeon in the area of the prosthesis **200** that is in the process of being sutured.



17

The surgeon may execute one or more stitches **11** (see FIG. **13**) for each free part **5b** of the four anchor pieces **5**.

As may be seen in FIG. **13**, the structure of the prosthesis **200** of the invention enables the surgeon to place the stitches **11** in an area situated more or less in the middle between the centre of the mesh **1** and the exterior peripheral edge **1a** thereof; thus the surgeon does not have to execute stitches at the exterior peripheral edge **1a** of the mesh **1**, which can be viewed only with difficulty because of the small size of the incision **110**. The mesh **1** nevertheless remains perfectly pressed against the abdominal wall **104** along this peripheral edge **1a** because of the presence of the frame **2**. Nevertheless, because of the structure of the prosthesis **200** of the invention, the stitches **11** are advantageously situated at some distance from the defect, in particular in an area more or less in the middle between the centre **1b** of the mesh (which is the location of the hernia defect) and the edge **1a** of the mesh, at a location where the biological tissues are often healthier and less fragile than at the margin of the defect. The stitches **11** may for example be U-shaped, i.e. obtained with a thread provided with a needle at each of its ends.

Once the surgeon has executed the necessary stitches **11** over all the anchor pieces **5**, he cuts each thread-shaped element, here each tube **7**, at its junction with the free part **5b** of the anchor piece **5** in order to retain at the implantation site only the anchor pieces **5**, as shown in FIG. **13**. This figure shows the stitches **11** that fix the free parts **5b** of the anchor pieces **5** to the abdominal wall **104**. As may be seen in FIG. **13**, the prosthesis **200** is thus perfectly deployed, spread out and pressed against the abdominal wall (**101**, **104**) with no risk of trapping viscera between the prosthesis **200** and the abdominal wall (**101**, **104**).

The surgeon then has only to close the incision **110** in the conventional way for small size hernias, i.e. by stitches.

The prosthesis of the invention is particularly simple to install, the surgeon being easily able to uncover a comfortable and non obstructed working area, despite the restricted size of the implantation site. The fitting of the prosthesis of the invention is also particularly reliable, all risk of trapping the viscera being avoided. A prosthesis of the invention is particularly suitable for treating umbilical hernias where the abdominal incision made is of small size. The prosthesis of the invention is adapted to adopt a configuration in which it occupies a particularly small volume facilitating its introduction into the abdominal cavity via a small incision without necessitating the use of any dedicated ancillary device. Thanks to its particular structure, the prosthesis of the invention may be spread out and pressed onto the abdominal wall efficaciously, also without necessitating the use of a dedicated tool to assist spreading it and it may be attached securely to the abdominal wall at an area located more or less in the middle between the centre of the prosthesis and its periphery: the surgeon is therefore prevented from having to make stitches at far distance places, such as the periphery of the prosthesis, that he cannot see. The prosthesis of the invention thus makes it possible to treat a hernia, in particular an umbilical hernia, efficaciously, simply and rapidly, minimizing the risk of relapse.

The invention claimed is:

1. A prosthesis comprising:

at least one flexible mesh delimited by a peripheral exterior edge,

at least one member for reinforcing said mesh, said reinforcing member taking the form of a frame fixed to said mesh and substantially adopting a shape of said peripheral exterior edge of the mesh, said frame being

18

set back from said peripheral exterior edge and defining an inner perimeter, the frame being provided with two hinge points, a folding line passing through said two hinge points also passing through a center of the mesh for folding the mesh in two

wherein said prosthesis further comprises at least two anchor pieces located on a single face of the mesh on either side of said folding line, each anchor piece is a triangular textile having a fixed part linked to said mesh via a base of the triangular textile, the base located along the inner perimeter of the frame and a free part, said free part being linked to at least one thread-shaped element.

2. A prosthesis according to claim 1, wherein each anchor piece is linked to the mesh by its longest side, along a direction perpendicular to a segment linking the center of the mesh and a point of fixation of said piece in a plane of the mesh.

3. A prosthesis according to claim 1, wherein the at least one thread-shaped elements are selected from threads, flexible tubes and combinations thereof.

4. A prosthesis according to claim 3, wherein the thread-shaped elements are flexible tubes.

5. A prosthesis according to claim 4, wherein the tubes are flexible and semi-rigid.

6. A prosthesis according to claim 1, wherein the frame set back from the peripheral external edge is of serpentine shape forming undulations.

7. A prosthesis according to claim 6, wherein said frame takes the form of a flat ribbon forming undulations substantially in a plane of said mesh.

8. A prosthesis according to claim 1, wherein said reinforcing member is produced in bioresorbable material.

9. A prosthesis according to claim 1, wherein said mesh is disc-shaped, said frame being substantially in a form of a circular ring.

10. A prosthesis according to claim 9, wherein said at least two anchor pieces are fixed to diametrically opposed places of an inner perimeter of said ring, said two places being spaced by 90° from each of said two hinge points.

11. A prosthesis according to claim 9, wherein the prosthesis comprises four said anchor pieces distributed substantially regularly along an inner perimeter of said ring so that two anchor pieces are located on one side of the folding line and the other two anchor pieces are located on the other side of said folding line.

12. A prosthesis according to claim 11, wherein a single thread-shaped element links together the free parts of two anchor pieces located on the same side of the folding line.

13. A prosthesis according to claim 11, wherein all four anchor pieces are under the form of isosceles triangles of textile, all four triangles showing identical elongation and tensile strength properties in a centripetal direction.

14. A prosthesis according to claim 1, wherein the anchor pieces have a color different than that of the mesh.

15. A prosthesis according to claim 1, wherein the thread-shaped elements have a color different than that of the mesh and than that of the anchor pieces.

16. A prosthesis according to claim 1, wherein the face of the mesh opposite that including said anchor pieces is covered by a non-adherent coating.

17. A prosthesis according to claim 1, wherein the at least two anchor pieces are separate individual pieces.

18. A prosthesis according to claim 1, wherein the at least one thread-shaped element comprises at least one thread linked to said free part of the at least two anchor pieces,

wherein the at least one thread passes through at least one flexible tube between said free part of the at least two anchor pieces.

19. A prosthesis according to claim 1, wherein the frame is fixed to an outer surface of said mesh. 5

20. A prosthesis according to claim 1, wherein the frame is rigid and the hinge points do not have any elasticity.

21. A prosthesis according to claim 20, wherein the prosthesis is configured to adopt only two configurations including a flat and spread out first configuration and a fold 10 evenly in two configuration.

22. A prosthesis comprising:

at least one flexible mesh delimited by a peripheral exterior edge,

at least one member for reinforcing said mesh, said 15 reinforcing member taking the form of a frame fastened to said mesh and substantially adopting a shape of said peripheral exterior edge of the mesh, said frame being set back from said peripheral exterior edge and defining an inner perimeter, the frame being provided with two 20 hinge points, a folding line passing through said two hinge points also passing through a center of the mesh for folding the mesh in two

wherein said prosthesis further comprises at least two anchor pieces located on a single face of the mesh on 25 either side of said line, each anchor piece is in a form of a triangular textile having a fixed part linked to said mesh via a base of the triangular textile located along the inner perimeter of the frame and a free part, said free part being linked to at least one thread-shaped 30 element.

\* \* \* \* \*