



(51) International Patent Classification:

A61B 8/08 (2006.01) G01N 29/24 (2006.01)
G01N 29/04 (2006.01) G02F 1/225 (2006.01)
G01N 29/06 (2006.01)

(US). **THORNTON, Michael, M.**; 100 Collip Circle, Suite 235, London, Ontario N6G 4X8 (CA). **STEINBERG, Idan**; 3600 Green Court, Suite 350, Ann Arbor, MI 48105 (US).

(21) International Application Number:

PCT/US2024/021952

(74) **Agent: JELIC, Stanley, E**; 3600 Green Court, Suite 350, Ann Arbor, MI 48105 (US).

(22) International Filing Date:

28 March 2024 (28.03.2024)

(81) **Designated States** (unless otherwise indicated, for every kind of national protection available): AE, AG, AL, AM, AO, AT, AU, AZ, BA, BB, BG, BH, BN, BR, BW, BY, BZ, CA, CH, CL, CN, CO, CR, CU, CV, CZ, DE, DJ, DK, DM, DO, DZ, EC, EE, EG, ES, FI, GB, GD, GE, GH, GM, GT, HN, HR, HU, ID, IL, IN, IQ, IR, IS, IT, JM, JO, JP, KE, KG, KH, KN, KP, KR, KW, KZ, LA, LC, LK, LR, LS, LU, LY, MA, MD, MG, MK, MN, MU, MW, MX, MY, MZ, NA, NG, NI, NO, NZ, OM, PA, PE, PG, PH, PL, PT, QA, RO, RS, RU, RW, SA, SC, SD, SE, SG, SK, SL, ST, SV, SY, TH, TJ, TM, TN, TR, TT, TZ, UA, UG, US, UZ, VC, VN, WS, ZA, ZM, ZW.

(25) Filing Language:

English

(26) Publication Language:

English

(30) Priority Data:

18/130,192 03 April 2023 (03.04.2023) US

(71) **Applicants: ENDRA LIFE SCIENCES INC.** [US/US]; 3600 Green Court, Suite 350, Ann Arbor, MI 48105 (US). **DUKE UNIVERSITY** [US/US]; 101 Science Drive, Durham, NC 27708 (US).

(72) **Inventors: DAVIS, Christopher, Nelson**; 3600 Green Court, Suite 350, ANN ARBOR, MI 48105 (US). **MAC-CARINI, Paolo**; 101 Science Drive, Durham, NC 27708

(84) **Designated States** (unless otherwise indicated, for every kind of regional protection available): ARIPO (BW, CV, GH, GM, KE, LR, LS, MW, MZ, NA, RW, SC, SD, SL, ST,

(54) Title: THERMOACOUSTIC MEASUREMENT PROBE

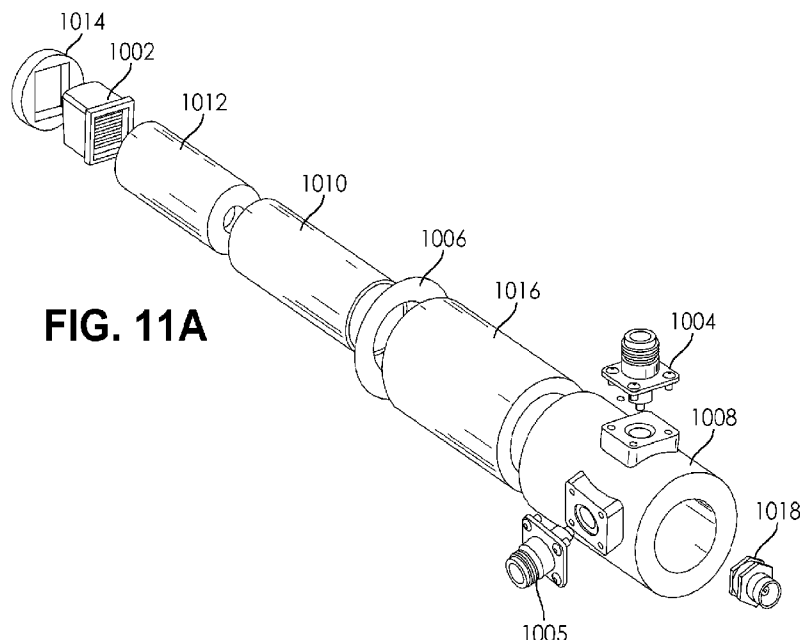

FIG. 11A

(57) **Abstract:** A thermoacoustic measurement probe includes an open-ended hollow radio-frequency (RF) waveguide; at least two RF feeds positioned within the open-ended hollow RF waveguide, wherein each RF feed is configured to provide RF energy; and a thermoacoustic transducer, wherein the open-ended hollow RF waveguide, in the form of a sleeve, surrounds and is mechanically joined to the thermoacoustic transducer.



SZ, TZ, UG, ZM, ZW), Eurasian (AM, AZ, BY, KG, KZ, RU, TJ, TM), European (AL, AT, BE, BG, CH, CY, CZ, DE, DK, EE, ES, FI, FR, GB, GR, HR, HU, IE, IS, IT, LT, LU, LV, MC, ME, MK, MT, NL, NO, PL, PT, RO, RS, SE, SI, SK, SM, TR), OAPI (BF, BJ, CF, CG, CI, CM, GA, GN, GQ, GW, KM, ML, MR, NE, SN, TD, TG).

Declarations under Rule 4.17:

— *of inventorship (Rule 4.17(iv))*

Published:

— *with international search report (Art. 21(3))*

THERMOACOUSTIC MEASUREMENT PROBE

TECHNICAL FIELD

[0001] The present disclosure enables a thermoacoustic measurement probe. In particular, the disclosure discussed structural configurations that enable a radio-frequency (RF) waveguide portion of a probe to surround a thermoacoustic transducer portion in a sleeve configuration and enable polarization of RF energy configured to emanate from the RF energy waveguide portion.

BACKGROUND

[0002] In high frequency systems, it is common to employ waveguides to guide electromagnetic waves or sound with minimal loss of energy by restricting expansion of the electromagnetic waves propagating within the waveguides to one or two dimensions. Depending on the nature of the electromagnetic waves to be propagated, the waveguides may take different forms. Also, in many instances, filters are employed to allow electromagnetic waves at some frequencies to pass and travel along the waveguides, while rejecting electromagnetic waves at other frequencies. One example is hollow, open-ended conductive waveguides, which are often employed for directing radio frequency (RF) waves. In some instances, to provide the desired filtering these hollow metal waveguides are fitted with a solid insert formed of high dielectric constant material.

[0003] Waveguides such as those described above have been employed in thermoacoustic imaging systems. Thermoacoustic imaging is an imaging modality that provides information relating to the thermoelastic properties of tissue. Thermoacoustic imaging uses short pulses of electromagnetic energy, such as RF pulses, directed into a medium to heat absorbing features within the medium rapidly, which in turn induces acoustic pressure waves that are detected using acoustic receivers such as one or more thermoacoustic or ultrasound transducer arrays. The detected acoustic pressure waves are analyzed through signal processing, and processed for presentation as thermoacoustic images that an operator can interpret.

[0004] In order to direct RF pulses into the medium during thermoacoustic imaging, an RF applicator employing a waveguide is coupled to tissue adjacent to a region of interest (ROI) within the medium to be imaged. Sub-optimal coupling of the RF applicator to the tissue may cause issues such as inefficient energy transfer, reduced heating rates, reduced signal intensity, non-uniform energy deposition, tissue hotspots, tissue overheating, RF power supply damage, and poor image quality. Factors that lead to sub-optimal coupling of the RF applicator to the tissue include variability in the medium's size, the size of tissue within the medium, the geometry of tissue within the medium, the composition of tissue within the medium, etc.

[0005] In a thermoacoustic probe, an RF applicator or RF antenna are used for transmitting RF energy into the medium of interest, and an acoustic receiver is used to pick

up the resulting thermoacoustic waves. It is common to configure the RF applicator and acoustic receiver side-by-side, integrated into a single handheld probe.

[0006] The side-by-side configuration may result in lower thermoacoustic signal strength, thereby reducing the effectiveness of thermoacoustic measurements. This is because the signal strength and extent of the imageable region are dependent on the extent of overlap between the RF applicator beam and the acoustic receiver's directivity pattern.

[0007] Another disadvantage of a side-by-side configuration for a thermoacoustic probe is that RF interference from the RF applicator may also adversely affect signal quality.

[0008] A third disadvantage of a side-by-side configuration for a thermoacoustic probe may be that spurious acoustic signals, such as an RF applicator plane wave, are stronger and are detrimental to acoustic signal fidelity.

[0009] In a side-by-side configuration, one proposed solution is to tilt the acoustic receiver in relation to RF applicator. This approach can allow for better overlap, but only a certain depth. Unfortunately, this will not improve RFI or reduce a large plane-wave artifact (unwanted signal noise) that occurs.

[0010] Another proposed solution is to separate the receiver and applicator into two different devices that can increase signal strength and reduce artifacts. Unfortunately, this approach introduces multiple complications and higher variability, as now an operator needs to manipulate two devices simultaneously, which represents a massive obstruction to the standard of care clinical workflow. In a thermoacoustic probe, an applicator or antenna are used for transmitting RF energy into the medium of interest and an acoustic receiver is used to pick up the resulting thermoacoustic waves.

[0011] The thermoacoustic signal response can be dependent on the polarization of the RF energy that is incident in the tissue of interest. For example, structures such as blood vessels will generate a stronger thermoacoustic response if the polarization is parallel to the vessel.

[0012] Physically changing the orientation of the RF Applicator can change the polarization in the tissue, but this can be imprecise and non-repeatable. Hence, this is not a good solution.

[0013] It is difficult and time-consuming to do a high resolution sweep of polarization. So, this is not a good solution either.

[0014] Hence, there is a need to develop a novel structural thermoacoustic probe configuration that overcomes the limitations inherent in a side-by-side thermoacoustic probe configuration and also enables RF energy polarization.

SUMMARY

[0015] In one embodiment, thermoacoustic measurement probe comprises an open-ended hollow radio-frequency (RF) waveguide; individual RF feeds positioned within the open-

ended hollow RF waveguide, wherein each individual RF feed is configured to provide RF energy at a different phase; and a thermoacoustic transducer; wherein the open-ended hollow RF waveguide, in the form of a sleeve, surrounds and is mechanically joined to the thermoacoustic transducer.

[0016] The open-ended hollow RF waveguide, in the form of a sleeve, may surround and be mechanically joined to the thermoacoustic transducer via insulation that protects the thermoacoustic transducer from acoustic and electrical interference emanating from the open-ended hollow RF waveguide.

[0017] The thermoacoustic transducer and open-ended hollow RF waveguide may form a circular cross-sectional shape.

[0018] The thermoacoustic transducer and open-ended hollow RF waveguide may form an elliptical cross-sectional shape.

[0019] A sensor of the thermoacoustic transducer may have a circular cross-sectional shape.

[0020] A sensor of the thermoacoustic transducer may have an elliptical cross-sectional shape.

[0021] A sensor of the thermoacoustic transducer may have a rectangular cross-sectional shape.

[0022] An end of a sensor of the thermoacoustic transducer may have a conical shape.

[0023] In another embodiment, a thermoacoustic measurement probe may comprise a radio-frequency (RF) waveguide having a cavity; individual RF feeds positioned within the RF waveguide, wherein each individual RF feed is configured to provide RF energy at a different phase; and a thermoacoustic transducer positioned in the cavity of the RF waveguide.

[0024] The cavity of the RF waveguide may have a circular cross-sectional shape.

[0025] The cavity of the RF waveguide may have an elliptical cross-sectional shape.

[0026] The cavity of the RF waveguide may have a rectangular cross-sectional shape.

[0027] A sensor of the thermoacoustic transducer may have a circular cross-sectional shape.

[0028] A sensor of the thermoacoustic transducer may have an elliptical cross-sectional shape.

[0029] A sensor of the thermoacoustic transducer may have a rectangular cross-sectional shape.

[0030] A sensor of the thermoacoustic transducer may have a conical shape.

[0031] A ceramic may be positioned in the cavity.

[0032] An acoustic isolation may be positioned in the ceramic.

[0033] The thermoacoustic measurement probe may comprise an RF feed coupled to the RF waveguide, and a connector coupled to the thermoacoustic transducer via an opening in the RF waveguide.

[0034] In yet another embodiment, a thermoacoustic measurement probe may comprise a cylindrical radio-frequency (RF) waveguide housing; individual RF feeds positioned within the RF waveguide housing, wherein each individual RF feed is configured to provide RF energy at a different phase; a cylindrical ceramic inside the cylindrical RF waveguide housing; a cylindrical acoustic isolation inside of the cylindrical ceramic; and a thermoacoustic sensor at an end of the cylindrical acoustic isolation.

[0035] In a separate embodiment, there are two individual RF feeds and they are located at 180 degrees relative to each other within the open-ended hollow RF waveguide.

[0036] In a separate embodiment, there are two individual RF feeds and they are located at 90 degrees relative to each other within the open-ended hollow RF waveguide.

[0037] In one embodiment, a thermoacoustic measurement probe may comprise an open-ended hollow radio-frequency (RF) waveguide; at least two RF feeds positioned within the open-ended hollow RF waveguide, wherein each RF feed is configured to provide RF energy; and a thermoacoustic transducer, wherein the open-ended hollow RF waveguide, in the form of a sleeve, surrounds and is mechanically joined to the thermoacoustic transducer.

[0038] The at least two RF feeds may be located at 180 degrees, 120 degrees, or 90 degrees relative to each other within the open-ended hollow RF waveguide.

[0039] The at least two RF feeds may comprise a first RF feed having a first phase and a second RF feed having a second phase different from the first phase.

[0040] The at least two RF feeds may comprise a first RF feed at a first power level and a second RF feed at a second power level different from the first power level. The at least two RF feeds may comprise a first RF feed and a second RF feed at the same power level.

[0041] In another embodiment, a thermoacoustic measurement probe may comprise a radio-frequency (RF) waveguide having a cavity; individual RF feeds positioned within the RF waveguide, wherein each individual RF feed is configured to provide RF energy at a different phase; and a thermoacoustic transducer positioned in the cavity of the RF waveguide.

[0042] The two individual RF feeds may be located at 180 degrees, 120 degrees, or 90 degrees relative to each other within the open-ended hollow RF waveguide.

[0043] The two individual RF feeds may comprise a first RF feed having a first phase and a second RF feed having a second phase completely out of phase from the first phase.

[0044] The two individual RF feeds may comprise a first RF feed at a first power level and a second RF feed at a second power level different from the first power level. The two individual RF feeds may comprise a first RF feed and a second RF feed at the same power level.

[0045] In yet another embodiment, a thermoacoustic measurement probe may comprise a cylindrical radio-frequency (RF) waveguide housing; a plurality of RF feeds positioned within the RF waveguide housing, wherein each RF feed is configured to provide RF energy; a cylindrical ceramic inside the cylindrical RF waveguide housing; a cylindrical acoustic isolation

inside of the cylindrical ceramic; and a thermoacoustic sensor at an end of the cylindrical acoustic isolation.

[0046] The plurality of RF feeds may be located at 180 degrees, 120 degrees, or 90 degrees relative to each other within the cylindrical RF waveguide housing.

[0047] The plurality of RF feeds are located at 90 degrees relative to each other within the cylindrical RF waveguide housing.

[0048] Each RF feed of the plurality of RF feeds may provide RF energy at a different phase.

[0049] The plurality of RF feeds may comprise a first RF feed at a first power level and a second RF feed at a second power level different from the first power level. The plurality of RF feeds may comprise a first RF feed and a second RF feed at the same power level.

[0050] In various embodiments, each said RF feed comprises an axis and said RF feeds have either parallel or non-parallel axes.

[0051] It should be appreciated that this summary is provided to introduce a selection of concepts in a simplified form that are further described below in the detailed description. This summary is not intended to be used to limit the scope of the claimed subject matter.

BRIEF DESCRIPTION OF THE DRAWINGS

[0052] Embodiments will now be described more fully with reference to the accompanying drawings in which:

[0053] FIG. 1 is a block diagram of a thermoacoustic system, according to an embodiment.

[0054] FIG. 2 is a cross-sectional side-view of an RF applicator and acoustic receiver side-by-side configuration, according to an embodiment.

[0055] FIG. 3 is a cross-sectional side-view of an RF applicator and acoustic receiver sleeve configuration, according to an embodiment.

[0056] FIG. 4 is a signal divergence comparison between a standard RF applicator used in the prior art and the sleeve RF applicator of the present application.

[0057] FIG. 5A is a front view of a first RF applicator and acoustic receiver sleeve configuration, according to an embodiment.

[0058] FIG. 5B is a perspective view of the first RF applicator and acoustic receiver sleeve configuration, according to an embodiment.

[0059] FIG. 5C is a side view of the first RF applicator and acoustic receiver sleeve configuration, according to an embodiment.

[0060] FIG. 5D is a top view of the first applicator and acoustic receiver sleeve configuration, according to an embodiment.

[0061] FIG. 6A is a front view of a second RF applicator and acoustic receiver sleeve configuration, according to an embodiment.

[0062] FIG. 6B is a perspective view of the second RF applicator and acoustic receiver sleeve configuration, according to an embodiment.

[0063] FIG. 6C is a side view of the second RF applicator and acoustic receiver sleeve configuration, according to an embodiment.

[0064] FIG. 6D is a top view of the second applicator and acoustic receiver sleeve configuration, according to an embodiment.

[0065] FIG. 7A is a front view of a third RF applicator and acoustic receiver sleeve configuration, according to an embodiment.

[0066] FIG. 7B is a perspective view of the third RF applicator and acoustic receiver sleeve configuration, according to an embodiment.

[0067] FIG. 7C is a side view of the third RF applicator and acoustic receiver sleeve configuration, according to an embodiment.

[0068] FIG. 7D is a top view of the third applicator and acoustic receiver sleeve configuration, according to an embodiment.

[0069] FIG. 8A is a front view of a fourth RF applicator and acoustic receiver sleeve configuration, according to an embodiment.

[0070] FIG. 8B is a perspective view of the fourth RF applicator and acoustic receiver sleeve configuration, according to an embodiment.

[0071] FIG. 8C is a side view of the fourth RF applicator and acoustic receiver sleeve configuration, according to an embodiment.

[0072] FIG. 8D is a top view of the fourth applicator and acoustic receiver sleeve configuration, according to an embodiment.

[0073] FIG. 9A is a front view of a fifth RF applicator and acoustic receiver sleeve configuration, according to an embodiment.

[0074] FIG. 9B is a perspective view of the fifth RF applicator and acoustic receiver sleeve configuration, according to an embodiment.

[0075] FIG. 9C is a side view of the fifth RF applicator and acoustic receiver sleeve configuration, according to an embodiment.

[0076] FIG. 9D is a top view of the fifth applicator and acoustic receiver sleeve configuration, according to an embodiment.

[0077] FIG. 10A is an exploded isometric view of a sixth RF applicator and acoustic receiver sleeve configuration, according to an embodiment.

[0078] FIG. 10B is an exploded side view of the sixth RF applicator and acoustic receiver sleeve configuration, according to an embodiment.

[0079] FIG. 10C is an exploded top view of the sixth RF applicator and acoustic receiver sleeve configuration, according to an embodiment.

[0080] FIG. 10D is an exploded side view of the sixth RF applicator and acoustic receiver sleeve configuration, according to an embodiment.

- [0081] FIG. 11A is an alternative exploded isometric view of the sixth RF applicator and acoustic receiver sleeve configuration, according to an embodiment.
- [0082] FIG. 11B is an alternative exploded side view of the sixth RF applicator and acoustic receiver sleeve configuration, according to an embodiment.
- [0083] FIG. 11C is an alternative exploded top view of the sixth RF applicator and acoustic receiver sleeve configuration, according to an embodiment.
- [0084] FIG. 11D is an alternative exploded side view of the sixth RF applicator and acoustic receiver sleeve configuration, according to an embodiment.
- [0085] FIG. 12A is an exploded isometric view of a seventh RF applicator and acoustic receiver sleeve configuration, according to an embodiment.
- [0086] FIG. 12B is an exploded side view of the seventh RF applicator and acoustic receiver sleeve configuration, according to an embodiment.
- [0087] FIG. 12C is an exploded top view of the seventh RF applicator and acoustic receiver sleeve configuration, according to an embodiment.
- [0088] FIG. 12D is an exploded side view of the seventh RF applicator and acoustic receiver sleeve configuration, according to an embodiment.
- [0089] FIG. 13A is an alternative exploded isometric view of the seventh RF applicator and acoustic receiver sleeve configuration, according to an embodiment.
- [0090] FIG. 13B is an alternative exploded side view of the seventh RF applicator and acoustic receiver sleeve configuration, according to an embodiment.
- [0091] FIG. 13C is an alternative exploded top view of the seventh RF applicator and acoustic receiver sleeve configuration, according to an embodiment.
- [0092] FIG. 13D is an alternative exploded side view of the seventh RF applicator and acoustic receiver sleeve configuration, according to an embodiment.
- [0093] FIG. 14 is a contour map showing electric field strength in decibels in different tissue types for the RF applicator, according to an embodiment.
- [0094] FIG. 15 shows electric field in the RF applicator in volts per meter, according to an embodiment.
- [0095] FIG. 16 shows reflected power in decibels at a target frequency for the RF applicator, according to an embodiment.
- [0096] FIG. 17 shows a side-view of electric field polarization with two feeds at 90 degrees relative to each other, according to an embodiment.
- [0097] FIG. 18 shows a side-view of electric field polarization with two feeds at 90 degrees relative to each other, according to an embodiment.
- [0098] FIG. 19 shows a side-view of electric field polarization with two feeds at 90 degrees relative to each other, according to an embodiment.
- [0099] FIG. 20 shows a side-view of electric field polarization with two feeds at 90 degrees relative to each other, according to an embodiment.

- [0100] FIG. 21 shows a side-view of electric field polarization with two feeds at 90 degrees relative to each other, according to an embodiment.
- [0101] FIG. 22 shows a side-view of electric field polarization with two feeds at 90 degrees relative to each other, according to an embodiment.
- [0102] FIG. 23 shows a side-view of electric field polarization with two feeds at 90 degrees relative to each other, according to an embodiment.
- [0103] FIG. 24 shows a side-view of electric field polarization with two feeds at 90 degrees relative to each other, according to an embodiment.
- [0104] FIG. 25 shows a side-view of electric field polarization with two feeds at 90 degrees relative to each other, according to an embodiment.
- [0105] FIG. 26 shows a side-view of electric field polarization with two feeds at 90 degrees relative to each other, according to an embodiment.
- [0106] FIG. 27 shows a side-view of electric field polarization with two feeds at 90 degrees relative to each other, according to an embodiment.
- [0107] FIG. 28 shows a side-view of electric field polarization with two feeds at 90 degrees relative to each other, according to an embodiment.
- [0108] FIG. 29A-29F show a side-view of electric field polarization with two feeds at 90 degrees relative to each other at six different points in a cycle, according to an embodiment.
- [0109] FIG. 30 shows an isometric view of electric field polarization with two feeds at 90 degrees relative to each other at a varying distance into tissue, according to an embodiment.
- [0110] FIG. 31 shows a side-view of electric field polarization with two feeds at 90 degrees relative to each other at a varying distance into tissue, according to an embodiment.
- [0111] FIG. 32 shows a side-view of electric field polarization with two feeds at 180 degrees relative to each other, according to an embodiment.
- [0112] FIG. 33 shows a side-view of electric field polarization with two feeds at 180 degrees relative to each other, according to an embodiment.
- [0113] FIG. 34 shows a side-view of electric field polarization with two feeds at 180 degrees relative to each other, according to an embodiment.
- [0114] FIG. 35 shows a side-view of electric field polarization with two feeds at 180 degrees relative to each other, according to an embodiment.
- [0115] FIG. 36 shows a side-view of electric field polarization with two feeds at 180 degrees relative to each other, according to an embodiment.
- [0116] FIG. 37 shows a side-view of electric field polarization with two feeds at 180 degrees relative to each other, according to an embodiment.
- [0117] FIG. 38 shows a side-view of electric field polarization with two feeds at 180 degrees relative to each other, according to an embodiment.
- [0118] FIG. 39 shows a side-view of electric field polarization with two feeds at 180 degrees relative to each other, according to an embodiment.

[0119] FIG. 40 shows a side-view of electric field polarization with two feeds at 180 degrees relative to each other, according to an embodiment.

[0120] FIG. 41 shows a side-view of electric field polarization with two feeds at 180 degrees relative to each other, according to an embodiment.

[0121] FIG. 42 shows a side-view of electric field polarization with two feeds at 180 degrees relative to each other, according to an embodiment.

[0122] FIG. 43 shows a side-view of electric field polarization with two feeds at 180 degrees relative to each other, according to an embodiment.

[0123] FIG. 44A-44F show a side-view of electric field polarization with two feeds at 180 degrees relative to each other at six different points in a cycle, according to an embodiment.

[0124] FIG. 45 shows an isometric view of electric field polarization with two feeds at 180 degrees relative to each other at a varying distance into tissue, according to an embodiment.

[0125] FIG. 46 shows a side-view of electric field polarization with two feeds at 180 degrees relative to each other at a varying distance into tissue, according to an embodiment.

[0126] FIG. 47 shows a side-view of electric field polarization with two feeds at 120 degrees relative to each other, according to an embodiment.

[0127] FIG. 48 shows a side-view of electric field polarization with two feeds at 120 degrees relative to each other, according to an embodiment.

[0128] FIG. 49 shows a side-view of electric field polarization with two feeds at 120 degrees relative to each other, according to an embodiment.

[0129] FIG. 50 shows a side-view of electric field polarization with two feeds at 120 degrees relative to each other, according to an embodiment.

[0130] FIG. 51 shows a side-view of electric field polarization with two feeds at 120 degrees relative to each other, according to an embodiment.

[0131] FIG. 52 shows a side-view of electric field polarization with two feeds at 120 degrees relative to each other, according to an embodiment.

[0132] FIG. 53 shows a side-view of electric field polarization with two feeds at 120 degrees relative to each other, according to an embodiment.

[0133] FIG. 54 shows a side-view of electric field polarization with two feeds at 120 degrees relative to each other, according to an embodiment.

[0134] FIG. 55 shows a side-view of electric field polarization with two feeds at 120 degrees relative to each other, according to an embodiment.

[0135] FIG. 56 shows a side-view of electric field polarization with two feeds at 120 degrees relative to each other, according to an embodiment.

[0136] FIG. 57 shows a side-view of electric field polarization with two feeds at 120 degrees relative to each other, according to an embodiment.

[0137] FIG. 58 shows a side-view of electric field polarization with two feeds at 120 degrees relative to each other, according to an embodiment.

[0138] FIG. 59A-59F show a side-view of electric field polarization with two feeds at 120 degrees relative to each other at six different points in a cycle, according to an embodiment.

[0139] FIG. 60 shows an isometric view of electric field polarization with two feeds at 120 degrees relative to each other at a varying distance into tissue, according to an embodiment.

[0140] FIG. 61 shows a side-view of electric field polarization with two feeds at 120 degrees relative to each other at a varying distance into tissue, according to an embodiment.

DETAILED DESCRIPTION

[0141] Embodiments herein describe a thermoacoustic measurement probe having an RF waveguide that surrounds a thermoacoustic transducer, and a housing of the thermoacoustic measurement probe contains both the RF waveguide and the thermoacoustic transducer.

[0142] Embodiments herein describe an improved method and system. Rather than utilizing an open-ended RF waveguide and a separate acoustic receiver, the embodiments discussed herein may utilize an open-ended hollow RF waveguide, wherein the hollow portion is a cavity configured for an acoustic receiver and any additional electronics to be mounted within that cavity. This configuration may allow the mechanical installation of the acoustic receiver (thermoacoustic transducer) and any additional electronics inside the hollow cavity. The open-ended RF waveguide may be configured in a form of a sleeve, which may partially or entirely surround the acoustic receiver. The RF waveguide may also be mechanically joined to the acoustic receiver.

[0143] For the purposes of this disclosure, the terms “feed” and “port” are used interchangeably.

[0144] The use of a hollow RF waveguide is not conventionally used with a component, such as a thermoacoustic transducer, in a hollow portion, because a component could affect the field and operation of the RF waveguide. In the embodiments described herein, the RF waveguide may be configured with a null region in the hollow portion.

[0145] An unexpected result of placing the acoustic receiver inside the hollow cavity of an open-ended hollow RF waveguide is that it allows for maximal overlap between the RF beam and the acoustic receiver’s directivity pattern.

[0146] Another unexpected result of utilizing an open-ended hollow RF waveguide is a very low electromagnetic field inside the hollow cavity. Placing the acoustic receiver inside the cavity (within the sleeve) reduces RF interferences significantly.

[0147] Another unexpected result is that the hollow RF waveguide has a highly divergent beam pattern near the RF waveguide. This, in turn, generates a diverging applicator plane wave which quickly disperses.

[0148] An unexpected result is that the hollow RF waveguide allows for smaller overall thermoacoustic measurement probe dimensions because the electronics and acoustic receiver can be placed inside the hollow cavity.

[0149] The cross-sectional shape of the hollow portion of the open-ended hollow RF waveguide can be any shape, including circular, elliptical, non-concentric tube, or tapered tube. The open-ended portion may contain a ceramic fill. In one embodiment, metal fins may be included in the ceramic fill or mounted on the RF waveguide to increase the frequency bandwidth over which the RF applicator can efficiently operate.

[0150] In one embodiment, the present disclosure enables an RF Applicator with electronic real-time adjustable polarization, including circular polarization. The RF applicator has adjustable polarization by electronically changing the relative phase between two or more RF energy feeds located within the RF Applicator.

[0151] The RF applicator can quickly sweep through polarizations at a measurement location and the resulting thermoacoustic response can be quantified versus polarization.

[0152] Polarization of the RF applicator can be precisely and repeatedly controlled by the relative phase between the RF energy feeds.

[0153] Turning now to FIG. 1, an imaging system is shown and is generally identified by reference numeral 100. As can be seen, the imaging system 100 comprises a programmed computing device 102 communicatively coupled to an ultrasound imaging system 104 and to a thermoacoustic imaging system 106. The ultrasound imaging system 104 and thermoacoustic imaging system 106 are configured to obtain ultrasound image data and thermoacoustic image data, respectively, of a region of interest (ROI) 116.

[0154] The programmed computing device 102 in this embodiment may be a personal computer, server, or other suitable processing device comprising, for example, a processing unit comprising one or more processors, computer-readable system memory (volatile and/or non-volatile memory), other non-removable or removable computer-readable memory (e.g., a hard disk drive, RAM, ROM, EEPROM, CD-ROM, DVD, flash memory, etc.) and a system bus coupling the various computer components to the processing unit. The computing device 102 may also comprise networking capabilities using Ethernet, Wi-Fi, and/or another suitable network format to enable connection to shared or remote drives, one or more networked computers, or other networked devices. One or more input devices, such as a mouse and a keyboard (not shown) are coupled to the computing device 102 for receiving operator input. A display device (not shown), such as one or more computer screens or monitors, may be coupled to the computing device 102 for displaying one or more generated images that are based on ultrasound image data received from the ultrasound imaging system 104 and/or the thermoacoustic image data received from the thermoacoustic imaging system 106. The programmed computing device 102 executes program code stored on the computer-readable system memory and/or other non-removable or removable computer-readable memory and performs methods according to the program code, as described further below.

[0155] The ultrasound imaging system 104 comprises an acoustic receiver in the form of an ultrasound transducer 108 that houses one or more ultrasound transducer arrays

configured to emit sound waves into the region of interest **116**. Sound waves directed into the region of interest **116** echo off materials within the region of interest, with different materials reflecting varying degrees of sound. Echoes that are received by the one or more ultrasound transducer arrays of the ultrasound transducer **108** are processed by the ultrasound imaging system **104**. The ultrasound imaging system **104** communicates ultrasound image data to the computing device **102** for further processing and for presentation on the display device as ultrasound images that an operator can interpret. In one embodiment, the ultrasound imaging system **104** utilizes B-mode ultrasound imaging techniques assuming a nominal speed of sound of 1,540 m/s. As ultrasound imaging systems are known in the art, further specifics of the ultrasound imaging system **104** will not be described further herein.

[0156] The thermoacoustic imaging system **106** comprises an acoustic receiver in the form of a thermoacoustic transducer **110**. The thermoacoustic transducer **110** houses one or more thermoacoustic transducer arrays. As described herein, although shown as separate components in the schematic **FIG. 1**, a radio-frequency (RF) applicator (or waveguide) **112** may be housed, combined, or integrated with the thermoacoustic transducer **110**. The RF applicator **112** is configured to emit short pulses of RF energy that are directed into the region of interest **116**. In one embodiment, the RF applicator **112** has a frequency between about 10MHz and 100GHz and has a pulse duration between about 0.1 nanoseconds and 10 microseconds. The RF applicator **112** emits RF energy pulses to materials or tissue within the region of interest **116** to induce acoustic pressure waves (thermoacoustic multi-polar signals) within the region of interest **116** that are detected by the thermoacoustic transducer **110**. Acoustic pressure waves detected by the thermoacoustic transducer **110** are processed and communicated as thermoacoustic image data to the computing device **102** for further processing and presentation on the display device as thermoacoustic images that the operator can interpret.

[0157] The coordinate system of the one or more ultrasound transducer arrays of the ultrasound transducer **108** and the coordinate system of the one or more thermoacoustic transducer arrays of the thermoacoustic transducer **110** are mapped by the computing device **102** so that acquired ultrasound and thermoacoustic images can be registered. Alternatively, the thermoacoustic imaging system **106** may make use of the one or more ultrasound transducer arrays of the ultrasound transducer **108** by disconnecting the one or more ultrasound transducer arrays from the ultrasound transducer **108** and connecting the one or more ultrasound transducer arrays to the thermoacoustic transducer **110**. As will be appreciated, by doing this coordinate mapping between the one or more ultrasound transducer arrays and the one or more thermoacoustic transducer arrays is not required.

[0158] In one embodiment (shown in **FIG. 1**), the region of interest **116** contains blood vessel **102** and is located within a liver **130** of a human or animal body (patient) **114**. Patient **114** comprises a subcutaneous fat layer **118** and muscle layer **120** adjacent to liver **130**.

Distances shown: d_f is the subcutaneous fat thickness of the patient **122**, d_m is the muscle thickness of the patient **124**, d_b is the distance from the boundary between the muscle and the liver to the center of the blood vessel **126**.

[0159] FIG. 2 is a cross-sectional side-view of an RF applicator and acoustic receiver side-by-side configuration embodiment. Shown are thermoacoustic transducer **210** including thermoacoustic sensor **202** and thermoacoustic electronics **204**, and RF applicator **212** including RF waveguide **206**, RF matching layer **208**, and RF applicator fill **214**. In the side-by-side configuration of FIG. 2, an area/volume of an electric field with sufficient magnitude to generate a thermoacoustic signal and the area/volume of receiver sensitivity to detect and utilize a thermoacoustic signal have a small region of overlap. Hence, a thermoacoustic analysis occurs within this small region of overlap.

[0160] The thermoacoustic transducer may be configured to be housed within a cavity **314** formed by the RF applicator. In one example, FIG. 3 is a cross-sectional side-view of an RF applicator and acoustic receiver configuration. Shown are open-ended hollow RF applicator **312**, open-ended hollow waveguide body **316**, open-ended hollow waveguide matching layer **306**, open-ended hollow waveguide fill **308**, thermoacoustic transducer **310**, thermoacoustic sensor **302**, thermoacoustic electronics **304**, and cavity **314** (which in one embodiment is filled with both acoustic and electromagnetic insulation). In this embodiment, the thermoacoustic transducer **310** is positioned within an interior region of the open-ended hollow RF applicator **312**. In this configuration of FIG. 3, an area/volume of an electric field with sufficient magnitude to generate a thermoacoustic signal and the area/volume of receiver sensitivity to detect and utilize a thermoacoustic signal have a larger region of overlap as compared to FIG. 2.

[0161] In one embodiment, open-ended hollow waveguide fill **308** comprises the volume between cavity outer wall **318** and open-ended hollow waveguide body outer wall **320**. Material used for the open-ended hollow waveguide fill **308** can be Strontium Titanate, Titanium Dioxide, Barium Strontium Titanate (BST). In one embodiment, the material used for the open-ended hollow waveguide fill **308** has a permittivity range of 10-250 relative real permittivity. In another embodiment, the material used for the open-ended hollow waveguide fill **308** has a Permittivity Loss Tangent from 0.00001 to 0.0050.

[0162] FIG. 4 illustrates a signal divergence comparison between a conventional RF applicator shown in FIG. 2 and the RF applicator configuration shown in FIG. 3. RF applicator **212** is shown as a solid RF applicator with a large aperture and a slow divergence of RF energy. Open-ended hollow RF applicator **312** is shown with a small aperture where the RF energy is emitted and rapid divergence of RF energy. The divergence of RF energy is inversely proportional to the antenna aperture: the smaller the aperture, the larger the divergence angle, and vice versa. As shown in FIG. 4, the open-ended hollow RF applicator **312** has a smaller

aperture, and this produces a larger divergence of the RF energy from the radiating surface of the applicator.

[0163] FIGS. 5A to 5D illustrate an RF applicator according to an embodiment. FIG. 5A is a front view of an RF applicator and acoustic receiver sleeve configuration embodiment. FIG. 5B is a perspective view of the RF applicator and acoustic receiver sleeve configuration embodiment. Shown are hollow cavity 502, open-ended hollow waveguide matching layer 506, open-ended hollow waveguide body 508, first RF energy feed 504, and second RF energy feed 505 rotated 180 degrees about the RF applicator from the first RF energy feed 504. FIG. 5C is a side view of the RF applicator and acoustic receiver sleeve configuration embodiment. FIG. 5D is a top view of the applicator and acoustic receiver sleeve configuration embodiment. In the illustrations of FIGS. 5A to 5D, the hollow cavity 502 is configured to receive an acoustic receiver (thermoacoustic transducer). The RF applicator may be considered an acoustic receiver sleeve because it is at least partially hollow and configured to house the acoustic receiver (not shown) in that opening. The acoustic receiver may fill all or a portion of the hollow cavity 502, and any portion of the hollow cavity 502 not filled by the acoustic receiver may be at least partially filled by another material, such as insulation.

[0164] As shown in examples of FIGS. 5A to 9D, an RF applicator and an acoustic receiver may have different shapes and configurations. The RF applicator may be circular, elliptical, or other configuration having an open-ended portion (e.g., cavity) for receiving the acoustic receiver. The acoustic receiver may have a rectangular, circular, elliptical, or other shape cross-section, and may have a rectangular, spherical, conical, or other shape end. FIGS. 5A to 9D are meant to be examples of configurations and the potential configurations are not limited to these particular examples. The shape may be selected based on the desired application or manufacturing processes.

[0165] In one configuration, the acoustic receiver may have a rectangular shape and be positioned in an RF applicator, as shown in FIGS. 6A to 6D. FIG. 6A is a front view of a second RF applicator and acoustic receiver sleeve configuration embodiment. FIG. 6B is a perspective view of a second RF applicator and acoustic receiver sleeve configuration embodiment. Shown are open-ended hollow waveguide matching layer 606, open-ended hollow waveguide body 608, first RF energy feed 604, second RF energy feed 605 rotated 90 degrees about RF applicator from the first RF energy feed 604, insulation 610, and rectangular acoustic receiver 602 (with rectangular cross-section). FIG. 6C is a side view of a second RF applicator and acoustic receiver sleeve configuration embodiment. FIG. 6D is a top view of a second applicator and acoustic receiver sleeve configuration embodiment.

[0166] In another configuration, an acoustic receiver may have a conical shape and be positioned in an RF applicator, as shown in FIGS. 7A to 7D. FIG. 7A is a front view of a third RF applicator and acoustic receiver sleeve configuration embodiment. FIG. 7B is a perspective view of a third RF applicator and acoustic receiver sleeve configuration

embodiment. Shown are open-ended hollow waveguide matching layer **706**, open-ended hollow waveguide body **708**, first RF energy feed **704**, second RF energy feed **705** rotated 180 degrees about the RF applicator from the first RF energy feed **704**, insulation **710**, and conical acoustic receiver **702** (with circular cross-section). **FIG. 7C** is a side view of a third RF applicator and acoustic receiver sleeve configuration embodiment. **FIG. 7D** is a top view of a third applicator and acoustic receiver sleeve configuration embodiment.

[0167] In another configuration, an acoustic receiver may have a rectangular shape and be positioned in an elliptical-shaped RF applicator, as shown in **FIGS. 8A to 8D**. **FIG. 8A** is a front view of a fourth RF applicator and acoustic receiver sleeve configuration embodiment. **FIG. 8B** is a perspective view of a fourth RF applicator and acoustic receiver sleeve configuration embodiment. Shown are open-ended hollow elliptical waveguide matching layer **806**, open-ended hollow elliptical waveguide body **808**, first RF energy feed **804**, second RF energy feed **805** rotated 180 degrees about the RF applicator from the first RF energy feed **804**, insulation **810**, and rectangular acoustic receiver **802** (with rectangular cross-section). **FIG. 8C** is a side view of a fourth RF applicator and acoustic receiver sleeve configuration embodiment. **FIG. 8D** is a top view of a fourth applicator and acoustic receiver sleeve configuration embodiment.

[0168] In another configuration, an acoustic receiver may have a conical shape and be positioned in an elliptical-shaped RF applicator, as shown in **FIGS. 9A to 9D**. **FIG. 9A** is a front view of a fifth RF applicator and acoustic receiver sleeve configuration embodiment. **FIG. 9B** is a perspective view of a fifth RF applicator and acoustic receiver sleeve configuration embodiment. Shown are open-ended hollow elliptical waveguide matching layer **906**, open-ended hollow elliptical waveguide body **908**, first RF energy feed **904**, second RF energy feed **905** rotated 180 degrees about the RF applicator from the first RF energy feed **904**, insulation **910**, and conical acoustic receiver **902** (with circular cross-section). **FIG. 9C** is a side view of a fifth RF applicator and acoustic receiver sleeve configuration embodiment. **FIG. 9D** is a top view of a fifth applicator and acoustic receiver sleeve configuration embodiment.

[0169] **FIGS. 10A to 11D** show a configuration having a circular acoustic receiver and a rectangular waveguide, as shown in **FIGS. 6A to 6D**. **FIG. 10A** is a perspective exploded view of a sixth RF applicator and acoustic receiver sleeve configuration, according to an embodiment. **FIG. 10B** is a side exploded view of the sixth RF applicator and acoustic receiver sleeve configuration, according to an embodiment. **FIG. 10C** is a top exploded view of the sixth RF applicator and acoustic receiver sleeve configuration, according to an embodiment. **FIG. 10D** is a side exploded view of the sixth RF applicator and acoustic receiver sleeve configuration, according to an embodiment.

[0170] A waveguide housing **1008** holds a ceramic **1016**. A waveguide matching layer **1006** abuts the ceramic **1016** at a first end of the waveguide housing **1008**. Acoustic isolation **1010** is positioned inside the waveguide housing **1008**. An inner Faraday cage **1012** is

positioned inside acoustic isolation **1010**. The acoustic isolation **1010** may comprise cork, foam, or the like, and it may be affixed to the ceramic **1016**. In some configurations (not shown), an air gap may be used. The inner Faraday cage **1012** is aligned with a thermoacoustic sensor **1002** having a seal **1014**. Although the sensor **1002** is shown as having a rectangular shape and a seal **1014** configured for a rectangular-shaped sensor **1002**, it is intended that this configuration may be adapted for other shapes of sensors. The waveguide housing **1008** is coupled to a first RF energy feed **1004** and second RF energy feed **1005**. A shielded connector **1018** for the inner Faraday cage **1012** is positioned at a second end of the waveguide housing **1008**.

[0171] FIGS. **11A** to **11D** show the components of FIGS. **10A** to **10D** from an alternative view. FIG. **11A** is an alternative perspective exploded view of the sixth RF applicator and acoustic receiver sleeve configuration, according to an embodiment. FIG. **11B** is an alternative side exploded view of the sixth RF applicator and acoustic receiver sleeve configuration, according to an embodiment. FIG. **11C** is an alternative top exploded view of the sixth RF applicator and acoustic receiver sleeve configuration, according to an embodiment. FIG. **11D** is an alternative side exploded view of the sixth RF applicator and acoustic receiver sleeve configuration, according to an embodiment.

[0172] FIGS. **12A** to **13D** show a configuration having a circular acoustic receiver and a rectangular waveguide, as shown in FIGS. **6A** to **6D**. FIG. **12A** is a perspective exploded view of a seventh RF applicator and acoustic receiver sleeve configuration, according to an embodiment. FIG. **12B** is a side exploded view of the seventh RF applicator and acoustic receiver sleeve configuration, according to an embodiment. FIG. **12C** is a top exploded view of the seventh RF applicator and acoustic receiver sleeve configuration, according to an embodiment. FIG. **12D** is a side exploded view of the seventh RF applicator and acoustic receiver sleeve configuration, according to an embodiment.

[0173] A waveguide housing **1208** holds a ceramic **1216**. Acoustic isolation **1210** is positioned inside the waveguide housing **1008**. At an end of the acoustic isolation **1210** is a thermoacoustic sensor (without a lens) **1202**. Although the sensor **1202** is shown as having a rectangular shape, it is intended that this configuration may be adapted for other shapes of sensors. Positioned on the sensor **1202** is a front, non-conductive seal **1214**, a thin conductive layer **1220**, an electromagnetic matching layer **1222**, and an acoustic lens **1224**. The waveguide housing **1208** is coupled to a first RF energy feed **1204** and second RF energy feed **1205**. A shielded connector **1218** and a back conductive seal **1226** are positioned at a second end of the waveguide housing **1208**.

[0174] FIGS. **13A** to **13D** show the components of FIGS. **12A** to **12D** from an alternative view. FIG. **13A** is an alternative perspective exploded view of the seventh RF applicator and acoustic receiver sleeve configuration, according to an embodiment. FIG. **13B** is an alternative side exploded view of the seventh RF applicator and acoustic receiver sleeve configuration,

according to an embodiment. **FIG. 13C** is an alternative top exploded view of the seventh RF applicator and acoustic receiver sleeve configuration, according to an embodiment. **FIG. 13D** is an alternative side exploded view of the seventh RF applicator and acoustic receiver sleeve configuration, according to an embodiment.

[0175] **FIG. 14** is a contour map showing electric field strength in decibels in different tissue types for the open-ended hollow RF applicator **312**. The electric field is shown exiting the open-ended hollow RF applicator **312** and traveling through a skin layer **1402**, fat layer **1404**, muscle layer **1406**, and liver layer **1408**. Contour line **1410** is 61 decibels, contour line **1412** is 53 decibels, contour line **1414** is 46 decibels, contour line **1416** is 23 decibels, contour line **1418** is 15 decibels, and contour line **1420** is 7 decibels. Peak electric field is shown near the open-ended hollow RF applicator **312** exit. As the electric field is dispersed through the tissue, the electric field becomes strongest near the thermoacoustic probe center axis **1422**. Both contour line **1418** and contour line **1420** are located in the liver layer **1408** and are strongest near the thermoacoustic probe center axis **1422**. This RF applicator configuration may be preferable to a side-by-side configuration of a RF applicator and acoustic receiver by having a field that converges along the center line and at the deeper end of the tissue rather than the skin layer **1402**.

[0176] **FIG. 15** shows electric field in the RF applicator in volts per meter. The hollow cavity **502** has a very low electric field of less than 400 volts per meter. In contrast, the open-ended hollow RF applicator **312** has an electric field that is greater than 1600 volts per meter. The electric field that is generated in the open-ended hollow RF applicator **312** cancels itself in the hollow cavity **502** due to the symmetrical nature (sleeve shape) of the open-ended hollow RF applicator **312** surrounding the hollow cavity **502**.

[0177] **FIG. 16** shows reflected power in decibels at a target frequency for the open-ended hollow RF applicator **312**. **FIG. 16** shows the reflection coefficient at a 50 ohm reference impedance versus frequency for the open-ended hollow RF applicator **312**. The reflection coefficient represents the amount of power that is transferred from a 50 ohm source into the open-ended hollow RF applicator **312** (i.e., reflected power). At 434 MHz, the design frequency of the open-ended hollow RF applicator **312**, the reflection coefficient is -26 dB, which corresponds to 99.75% of the power from a 50 ohm source being transferred to the open-ended hollow RF applicator **312**.

[0178] By controlling the relative phase and power between individual RF feeds positioned within the RF waveguide housing, the thermoacoustic measurement probe can generate any polarization state of the electromagnetic field: a linear polarization in any direction, a circular or an elliptic polarization.

[0179] The thermoacoustic signal response can depend on the polarization of the RF energy that is incident in the tissue of interest. For example, structures, such as blood vessels, may generate a stronger thermoacoustic response if the polarization is parallel to the vessel.

Thus, a highly organized tissue will have different electromagnetic properties in different directions. The degree of organization can be assessed by performing multiple measurements with different linear polarizations. In other cases, where the only property of interest is the bulk tissue absorption, a circular polarization may be advantageous as the results are independent of how the operator positions the thermoacoustic measurement probe.

[0180] Using multiple feed configurations for the RF applicator, the electric field can be varied at an organ (e.g., liver) or depth of tissue. Some structures, like blood vessels, may be more or less sensitive based on the electric field. The configurations allow for imaging a tumor having a random blood vessel orientation that may be insensitive to a direction of the electric field. The configurations may also be useful to directionally avoid structure, e.g., avoid ribs so that a liver can absorb more energy and provide a better signal back.

[0181] FIGS. 17 to 61 represent a an electric field through a layer or layers, such as liver layer 1408. FIGS. 17 to 61 show two feeds of an open-ended hollow RF applicator, where the two feeds may vary in position, amount of power, and may be in a same or different phase from each other. Although only two feeds are shown in these illustrative embodiments, it is intended that two or more feeds may be utilized. The feeds are also shown as being rotated along a circular-shaped RF applicator by 90 degrees, 120 degrees, and 180 degrees, but it is intended that the feeds may be positioned at any angles along the RF applicator. The feeds are also not limited to being positioned at the same depth of the RF applicator.

[0182] FIGS. 17 to 28 show a side-view of electric field polarization with two feeds at 90 degrees relative to each other. The side-view of electric field polarization is shown at the face of the open-ended hollow RF applicator 1703. The figures show directional electric field flow vectors at a variety of different phase and power levels for each feed. Smaller arrows 1701 have lower electric field magnitude while larger arrows 1702 have higher electric field magnitude.

[0183] FIG. 17 shows a side-view of electric field polarization with two feeds at 90 degrees relative to each other. Feed 1 is at 0 degrees phase and 0 percent power. Feed 2 is at 0 degrees phase and 100 percent power. Port 1 center axis 1704 runs along the center of port 1 and port 2 center axis 1705 runs along the center of port 2. Center axes 1704 and 1705 are shown as non-parallel.

[0184] FIG. 18 shows a side-view of electric field polarization with two feeds at 90 degrees relative to each other. Feed 1 is at 0 degrees phase and 50 percent power. Feed 2 is at 0 degrees phase and 50 percent power.

[0185] FIG. 19 shows a side-view of electric field polarization with two feeds at 90 degrees relative to each other. Feed 1 is at 0 degrees phase and 100 percent power. Feed 2 is at 0 degrees phase and 0 percent power.

[0186] FIG. 20 shows a side-view of electric field polarization with two feeds at 90 degrees relative to each other. Feed 1 is at 0 degrees phase and 100 percent power. Feed 2 is at 180 degrees phase and 0 percent power.

[0187] FIG. 21 shows a side-view of electric field polarization with two feeds at 90 degrees relative to each other. Feed 1 is at 0 degrees phase and 50 percent power. Feed 2 is at 180 degrees phase and 50 percent power.

[0188] FIG. 22 shows a side-view of electric field polarization with two feeds at 90 degrees relative to each other. Feed 1 is at 0 degrees phase and 0 percent power. Feed 2 is at 180 degrees phase and 100 percent power.

[0189] FIG. 23 shows a side-view of electric field polarization with two feeds at 90 degrees relative to each other. Feed 1 is at 180 degrees phase and 0 percent power. Feed 2 is at 180 degrees phase and 100 percent power.

[0190] FIG. 24 shows a side-view of electric field polarization with two feeds at 90 degrees relative to each other. Feed 1 is at 180 degrees phase and 50 percent power. Feed 2 is at 180 degrees phase and 50 percent power.

[0191] FIG. 25 shows a side-view of electric field polarization with two feeds at 90 degrees relative to each other. Feed 1 is at 180 degrees phase and 100 percent power. Feed 2 is at 180 degrees phase and 0 percent power.

[0192] FIG. 26 shows a side-view of electric field polarization with two feeds at 90 degrees relative to each other. Feed 1 is at 180 degrees phase and 100 percent power. Feed 2 is at 0 degrees phase and 0 percent power.

[0193] FIG. 27 shows a side-view of electric field polarization with two feeds at 90 degrees relative to each other. Feed 1 is at 180 degrees phase and 50 percent power. Feed 2 is at 0 degrees phase and 50 percent power.

[0194] FIG. 28 shows a side-view of electric field polarization with two feeds at 90 degrees relative to each other. Feed 1 is at 180 degrees phase and 0 percent power. Feed 2 is at 0 degrees phase and 100 percent power.

[0195] FIGS. 29A-29F show a side-view of electric field polarization with two feeds at 90 degrees relative to each other at six different points in a cycle, according to an embodiment. The electric field polarizations are shown at different phases of a cycle: 0 degrees, 72 degrees, 144 degrees, 216 degrees, 288 degrees, and 360 degrees (which is the same as 0 degrees).

[0196] FIG. 30 shows an isometric view of electric field polarization with two feeds at 90 degrees relative to each other at a varying distance into tissue, according to an embodiment. Feed 1 is at 0 degrees phase and 50 percent power. Feed 2 is at 90 degrees phase and 50 percent power. Directional energy vectors are shown rotating about an axis that is perpendicular to the center of the face of the RF applicator 312. These energy vectors rotate 360 degrees per cycle about the axis that is perpendicular to the center of the face of the RF applicator 312.

[0197] FIG. 31 shows a side-view of electric field polarization with two feeds at 90 degrees relative to each other at a varying distance into tissue. Feed 1 is at 0 degrees phase and 50 percent power. Feed 2 is at 90 degrees phase and 50 percent power. Directional energy vectors are shown rotating about an axis that is perpendicular to the center of the face of the RF applicator 312. These energy vectors rotate 360 degrees per cycle about the axis that is perpendicular to the center of the face of the RF applicator 312.

[0198] FIGS. 32 to 43 show a side-view of electric field polarization with two feeds at 180 degrees relative to each other. The side-view of electric field polarization is shown at the face of the open-ended hollow RF applicator 1703. The figures show directional electric field flow vectors at a variety of different phase and power levels for each feed. Smaller arrows 1701 have lower electric field magnitude while larger arrows 1702 have higher electric field magnitude.

[0199] FIG. 32 shows a side-view of electric field polarization with two feeds at 180 degrees relative to each other. Feed 1 is at 0 degrees phase and 0 percent power. Feed 2 is at 0 degrees phase and 100 percent power. Port 1 center axis 3204 runs along the center of port 1 and port 2 center axis 3205 runs along the center of port 2. Center axes 3204 and 3205 are shown as parallel.

[0200] FIG. 33 shows a side-view of electric field polarization with two feeds at 180 degrees relative to each other. Feed 1 is at 0 degrees phase and 50 percent power. Feed 2 is at 0 degrees phase and 50 percent power.

[0201] FIG. 34 shows a side-view of electric field polarization with two feeds at 180 degrees relative to each other. Feed 1 is at 0 degrees phase and 100 percent power. Feed 2 is at 0 degrees phase and 0 percent power.

[0202] FIG. 35 shows a side-view of electric field polarization with two feeds at 180 degrees relative to each other. Feed 1 is at 0 degrees phase and 100 percent power. Feed 2 is at 180 degrees phase and 0 percent power.

[0203] FIG. 36 shows a side-view of electric field polarization with two feeds at 180 degrees relative to each other. Feed 1 is at 0 degrees phase and 50 percent power. Feed 2 is at 180 degrees phase and 50 percent power.

[0204] FIG. 37 shows a side-view of electric field polarization with two feeds at 180 degrees relative to each other. Feed 1 is at 0 degrees phase and 0 percent power. Feed 2 is at 180 degrees phase and 100 percent power.

[0205] FIG. 38 shows a side-view of electric field polarization with two feeds at 180 degrees relative to each other. Feed 1 is at 180 degrees phase and 0 percent power. Feed 2 is at 180 degrees phase and 100 percent power.

[0206] FIG. 39 shows a side-view of electric field polarization with two feeds at 180 degrees relative to each other. Feed 1 is at 180 degrees phase and 50 percent power. Feed 2 is at 180 degrees phase and 50 percent power.

[0207] FIG. 40 shows a side-view of electric field polarization with two feeds at 180 degrees relative to each other. Feed 1 is at 180 degrees phase and 100 percent power. Feed 2 is at 180 degrees phase and 0 percent power.

[0208] FIG. 41 shows a side-view of electric field polarization with two feeds at 180 degrees relative to each other. Feed 1 is at 180 degrees phase and 100 percent power. Feed 2 is at 0 degrees phase and 0 percent power.

[0209] FIG. 42 shows a side-view of electric field polarization with two feeds at 180 degrees relative to each other. Feed 1 is at 180 degrees phase and 50 percent power. Feed 2 is at 0 degrees phase and 50 percent power.

[0210] FIG. 43 shows a side-view of electric field polarization with two feeds at 180 degrees relative to each other. Feed 1 is at 180 degrees phase and 0 percent power. Feed 2 is at 0 degrees phase and 100 percent power.

[0211] FIGS. 44A-44F show a side-view of electric field polarization with two feeds at 180 degrees relative to each other at six different points in a cycle, according to an embodiment. The electric field polarizations are shown at different phases of a cycle: 0 degrees, 72 degrees, 144 degrees, 216 degrees, 288 degrees, and 360 degrees (which is the same as 0 degrees).

[0212] FIG. 45 shows an isometric view of electric field polarization with two feeds at 180 degrees relative to each other at a varying distance into tissue, according to an embodiment. Feed 1 is at 0 degrees phase and 50 percent power. Feed 2 is at 90 degrees phase and 50 percent power. Directional energy vectors are shown rotating about an axis that is perpendicular to the center of the face of the RF applicator 312. These energy vectors rotate 360 degrees per cycle about the axis that is perpendicular to the center of the face of the RF applicator 312.

[0213] FIG. 46 shows a side-view of electric field polarization with two feeds at 180 degrees relative to each other at a varying distance into tissue. Feed 1 is at 0 degrees phase and 50 percent power. Feed 2 is at 90 degrees phase and 50 percent power. Directional energy vectors are shown rotating about an axis that is perpendicular to the center of the face of the RF applicator 312. These energy vectors rotate 360 degrees per cycle about the axis that is perpendicular to the center of the face of the RF applicator 312.

[0214] FIGS. 47 to 58 show a side-view of electric field polarization with two feeds at 120 degrees relative to each other. The side-view of electric field polarization is shown at the face of the open-ended hollow RF applicator 1703. The figures show directional electric field flow vectors at a variety of different phase and power levels for each feed. Smaller arrows 1701 have lower electric field magnitude while larger arrows 1702 have higher electric field magnitude.

[0215] FIG. 47 shows a side-view of electric field polarization with two feeds at 120 degrees relative to each other. Feed 1 is at 0 degrees phase and 0 percent power. Feed 2 is at 0 degrees phase and 100 percent power.

[0216] FIG. 48 shows a side-view of electric field polarization with two feeds at 120 degrees relative to each other. Feed 1 is at 0 degrees phase and 50 percent power. Feed 2 is at 0 degrees phase and 50 percent power.

[0217] FIG. 49 shows a side-view of electric field polarization with two feeds at 120 degrees relative to each other. Feed 1 is at 0 degrees phase and 100 percent power. Feed 2 is at 0 degrees phase and 0 percent power.

[0218] FIG. 50 shows a side-view of electric field polarization with two feeds at 120 degrees relative to each other. Feed 1 is at 0 degrees phase and 100 percent power. Feed 2 is at 180 degrees phase and 0 percent power.

[0219] FIG. 51 shows a side-view of electric field polarization with two feeds at 120 degrees relative to each other. Feed 1 is at 0 degrees phase and 50 percent power. Feed 2 is at 180 degrees phase and 50 percent power.

[0220] FIG. 52 shows a side-view of electric field polarization with two feeds at 120 degrees relative to each other. Feed 1 is at 0 degrees phase and 0 percent power. Feed 2 is at 180 degrees phase and 100 percent power.

[0221] FIG. 53 shows a side-view of electric field polarization with two feeds at 120 degrees relative to each other. Feed 1 is at 180 degrees phase and 0 percent power. Feed 2 is at 180 degrees phase and 100 percent power.

[0222] FIG. 54 shows a side-view of electric field polarization with two feeds at 120 degrees relative to each other. Feed 1 is at 180 degrees phase and 50 percent power. Feed 2 is at 180 degrees phase and 50 percent power.

[0223] FIG. 55 shows a side-view of electric field polarization with two feeds at 120 degrees relative to each other. Feed 1 is at 180 degrees phase and 100 percent power. Feed 2 is at 180 degrees phase and 0 percent power.

[0224] FIG. 56 shows a side-view of electric field polarization with two feeds at 120 degrees relative to each other. Feed 1 is at 180 degrees phase and 100 percent power. Feed 2 is at 0 degrees phase and 0 percent power.

[0225] FIG. 57 shows a side-view of electric field polarization with two feeds at 120 degrees relative to each other. Feed 1 is at 180 degrees phase and 50 percent power. Feed 2 is at 0 degrees phase and 50 percent power.

[0226] FIG. 58 shows a side-view of electric field polarization with two feeds at 120 degrees relative to each other. Feed 1 is at 180 degrees phase and 0 percent power. Feed 2 is at 0 degrees phase and 100 percent power.

[0227] FIGS. 59A-59F show a side-view of electric field polarization with two feeds at 120 degrees relative to each other at six different points in a cycle, according to an embodiment. The electric field polarizations are shown at different phases of a cycle: 0 degrees, 72 degrees, 144 degrees, 216 degrees, 288 degrees, and 360 degrees (which is the same as 0 degrees).

[0228] FIG. 60 shows an isometric view of electric field polarization with two feeds at 120 degrees relative to each other at a varying distance into tissue. Feed 1 is at 0 degrees phase and 50 percent power. Feed 2 is at 90 degrees phase and 50 percent power. Directional energy vectors are shown rotating about an axis that is perpendicular to the center of the face of the RF applicator 312. These energy vectors rotate 360 degrees per cycle about the axis that is perpendicular to the center of the face of the RF applicator 312.

[0229] FIG. 61 shows a side-view of electric field polarization with two feeds at 120 degrees relative to each other at a varying distance into tissue. Feed 1 is at 0 degrees phase and 50 percent power. Feed 2 is at 90 degrees phase and 50 percent power. Directional energy vectors are shown rotating about an axis that is perpendicular to the center of the face of the RF applicator 312. These energy vectors rotate 360 degrees per cycle about the axis that is perpendicular to the center of the face of the RF applicator 312.

[0230] Although embodiments have been described above with reference to the accompanying drawings, those of skill in the art will appreciate that variations and modifications may be made without departing from the scope thereof as defined by the appended claims.

CLAIMS

What is claimed is:

1. A thermoacoustic measurement probe comprising:
an open-ended hollow radio-frequency (RF) waveguide;
at least two RF feeds positioned within the open-ended hollow RF waveguide,
wherein each RF feed is configured to provide RF energy; and
a thermoacoustic transducer,
wherein the open-ended hollow RF waveguide, in the form of a sleeve, surrounds
and is mechanically joined to the thermoacoustic transducer.
2. The thermoacoustic measurement probe of claim 1, wherein each said RF feed
comprises an axis and said RF feeds have parallel axes.
3. The thermoacoustic measurement probe of claim 1, wherein each said RF feed
comprises an axis and said RF feeds have non-parallel axes.
4. The thermoacoustic measurement probe of claim 1, wherein the open-ended hollow
RF waveguide comprises an open-ended hollow waveguide fill and an interior region, further
wherein said at least two RF feeds are positioned within the open-ended hollow waveguide
fill.
5. The thermoacoustic measurement probe of claim 1, wherein the at least two RF
feeds comprise a first RF feed having a first phase and a second RF feed having a second
phase different from the first phase.
6. The thermoacoustic measurement probe of claim 1, wherein the at least two RF
feeds comprise a first RF feed at a first power level and a second RF feed at a second
power level different from the first power level.
7. The thermoacoustic measurement probe of claim 1, wherein the at least two RF
feeds comprise a first RF feed and a second RF feed at the same power level.
8. A thermoacoustic measurement probe comprising:
a radio-frequency (RF) waveguide having a cavity;
individual RF feeds positioned within the RF waveguide, wherein each individual RF
feed is configured to provide RF energy at a different phase; and
a thermoacoustic transducer positioned in the cavity of the RF waveguide.

9. The thermoacoustic measurement probe of claim 8, wherein each said RF feed comprises an axis and said RF feeds have parallel axes.
10. The thermoacoustic measurement probe of claim 8, wherein each said RF feed comprises an axis and said RF feeds have non-parallel axes.
11. The thermoacoustic measurement probe of claim 8, wherein the open-ended hollow RF waveguide comprises an open-ended hollow waveguide fill and an interior region, further wherein said at least two RF feeds are positioned within the open-ended hollow waveguide fill.
12. The thermoacoustic measurement probe of claim 8, wherein the two individual RF feeds comprise a first RF feed having a first phase and a second RF feed having a second phase completely out of phase from the first phase.
13. The thermoacoustic measurement probe of claim 8, wherein the two individual RF feeds comprise a first RF feed at a first power level and a second RF feed at a second power level different from the first power level.
14. The thermoacoustic measurement probe of claim 8, wherein the two individual RF feeds comprise a first RF feed and a second RF feed at the same power level.
15. A thermoacoustic measurement probe comprising:
 - a cylindrical radio-frequency (RF) waveguide housing;
 - a plurality of RF feeds positioned within the RF waveguide housing, wherein each RF feed is configured to provide RF energy;
 - a cylindrical ceramic inside the cylindrical RF waveguide housing;
 - a cylindrical acoustic isolation inside of the cylindrical ceramic; and
 - a thermoacoustic sensor at an end of the cylindrical acoustic isolation.
16. The thermoacoustic measurement probe of claim 15, wherein each said RF feed comprises an axis and said RF feeds have parallel axes.
17. The thermoacoustic measurement probe of claim 15, wherein the plurality of RF feeds are located at 90 degrees relative to each other within the cylindrical RF waveguide housing.

18. The thermoacoustic measurement probe of claim 15, wherein each said RF feed comprises an axis and said RF feeds have non-parallel axes.
19. The thermoacoustic measurement probe of claim 15, wherein the open-ended hollow RF waveguide comprises an open-ended hollow waveguide fill and an interior region, further wherein said at least two RF feeds are positioned within the open-ended hollow waveguide fill.
20. The thermoacoustic measurement probe of claim 15, wherein the plurality of RF feeds comprise a first RF feed and a second RF feed at the same power level.

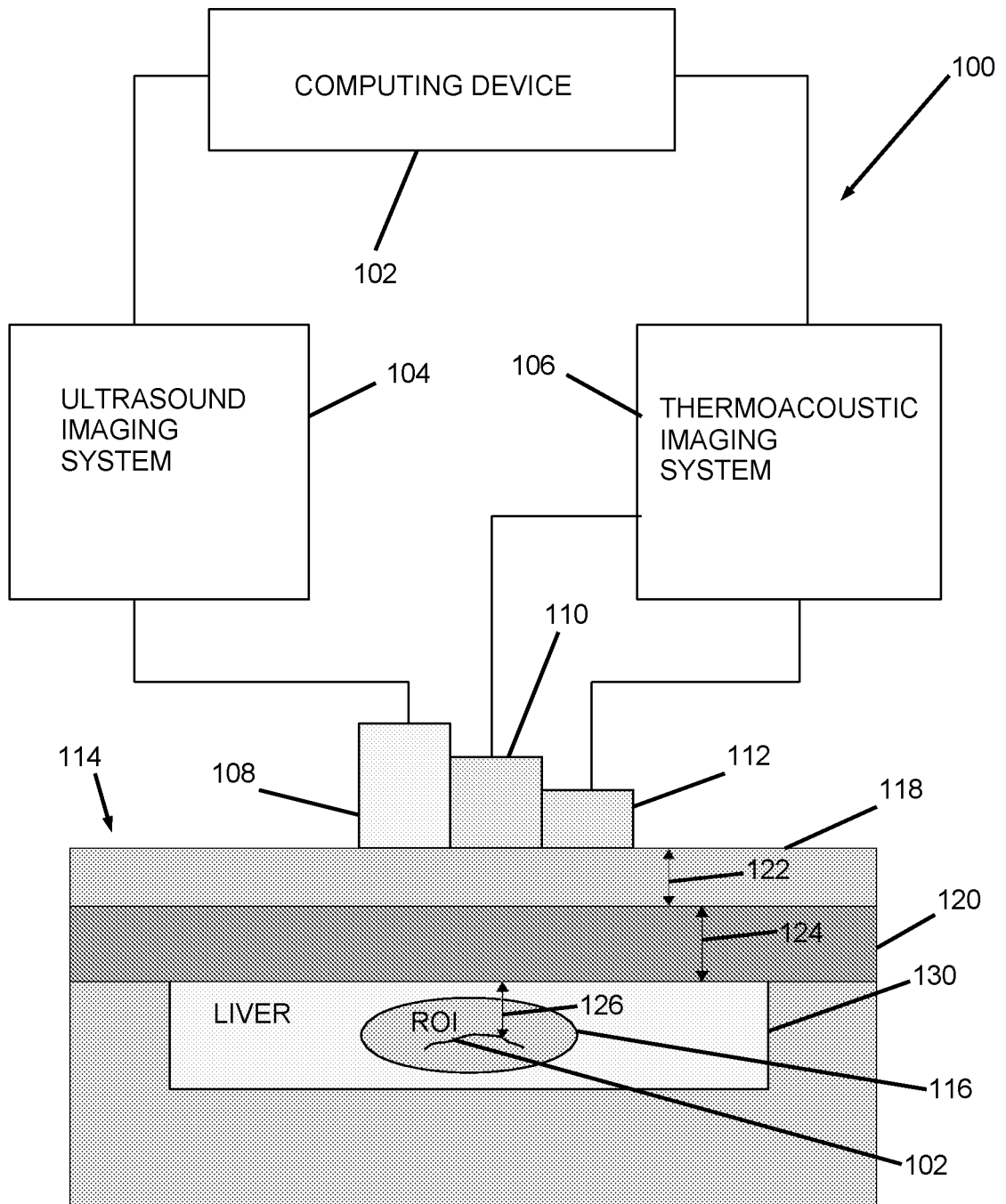

FIG. 1

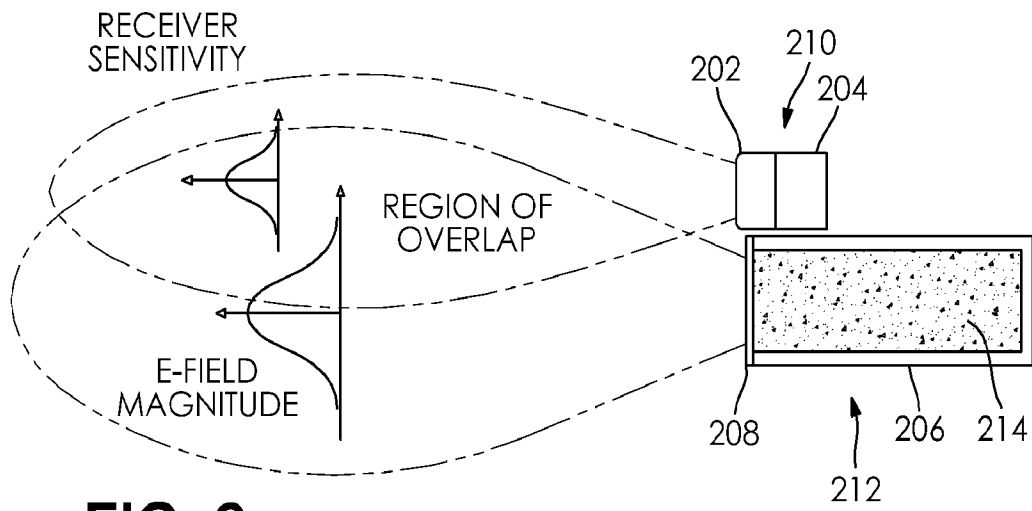

FIG. 2

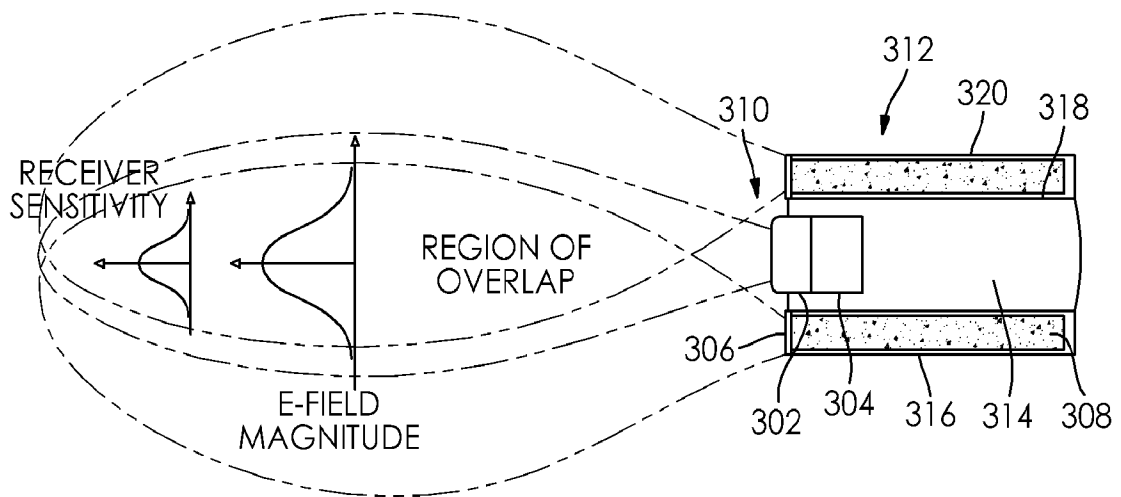

FIG. 3

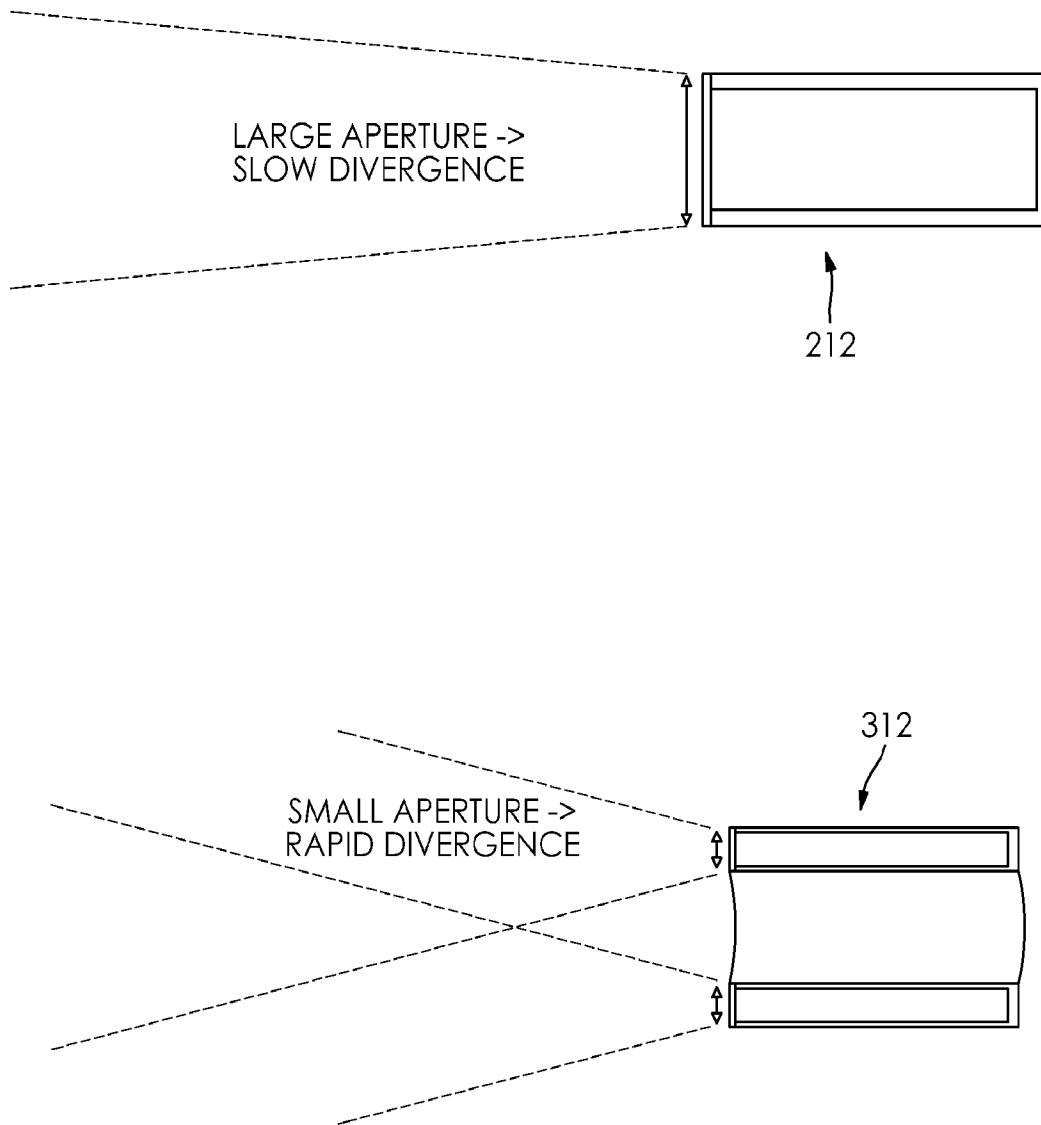

FIG. 4

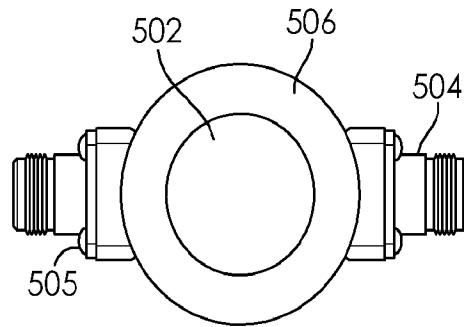

FIG. 5A

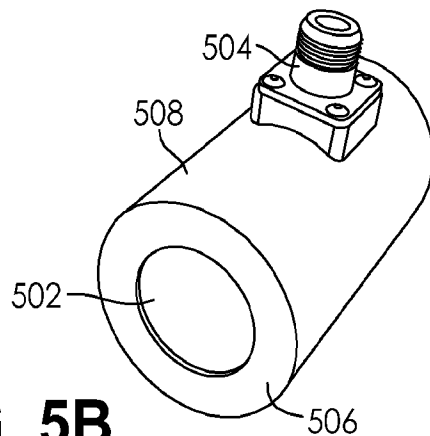

FIG. 5B

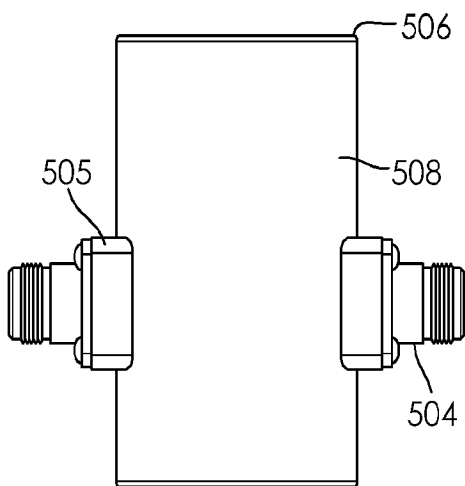

FIG. 5C

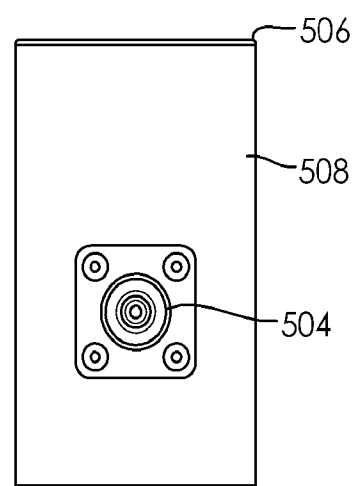

FIG. 5D

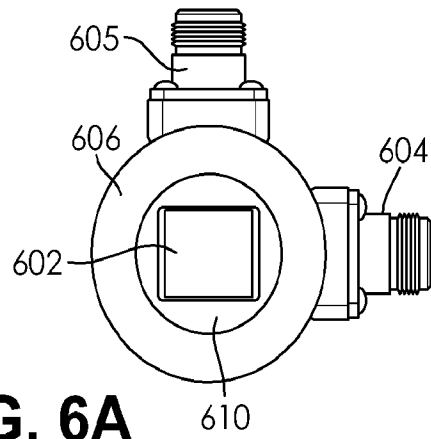

FIG. 6A

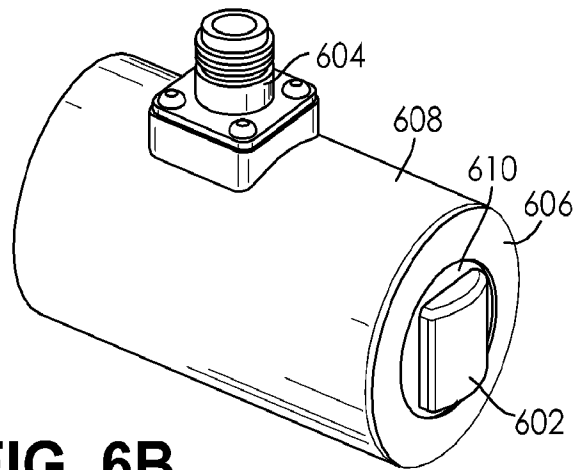

FIG. 6B

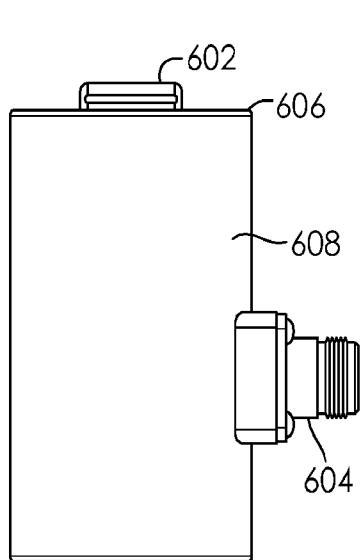

FIG. 6C

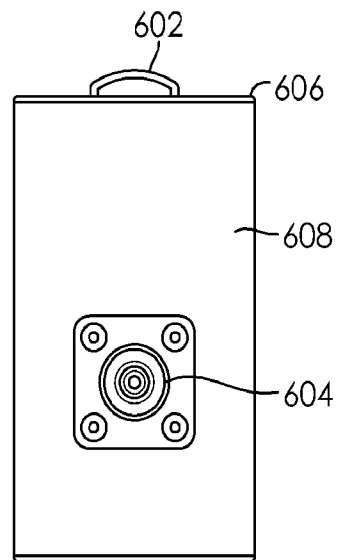

FIG. 6D

6/37

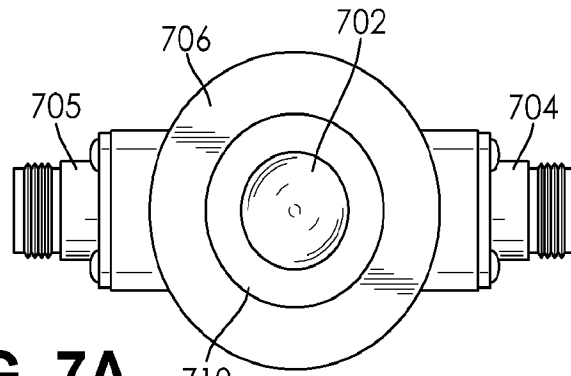

FIG. 7A

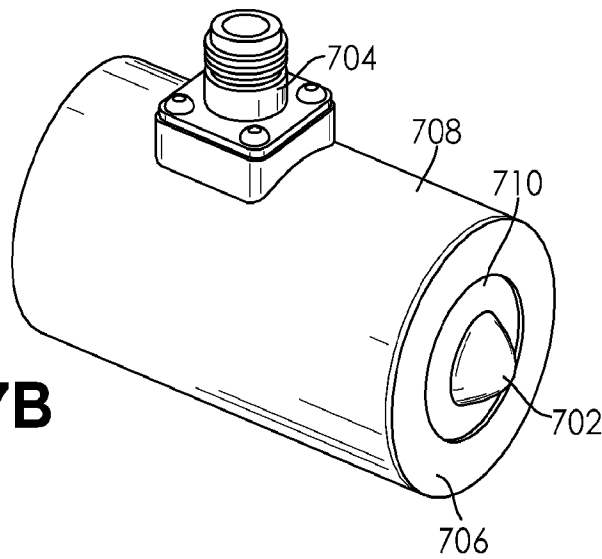

FIG. 7B

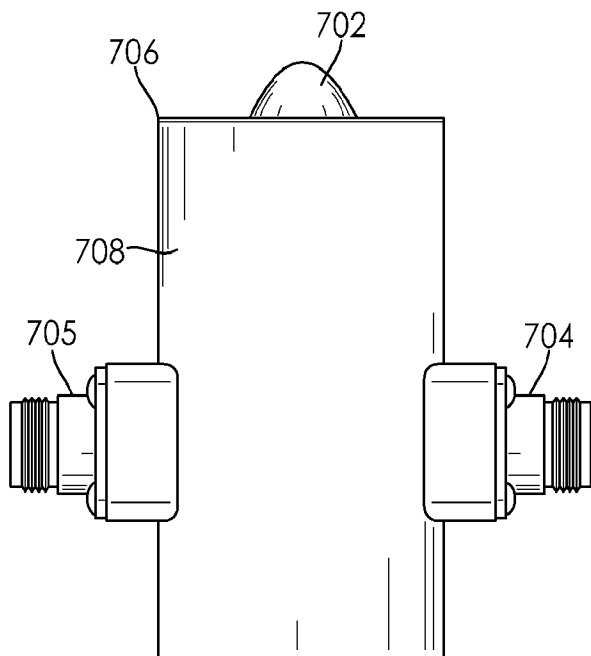

FIG. 7C

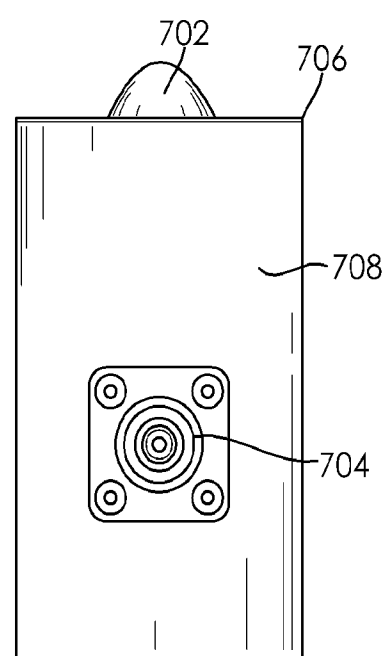

FIG. 7D

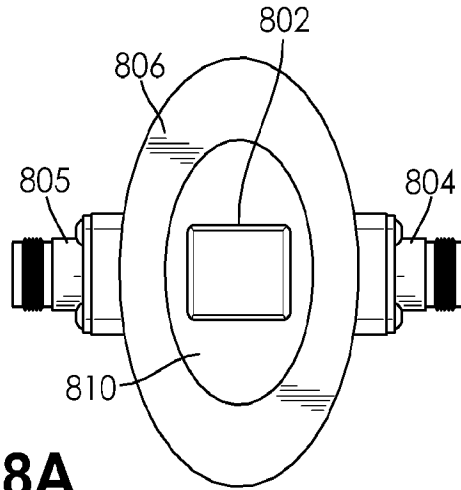

FIG. 8A

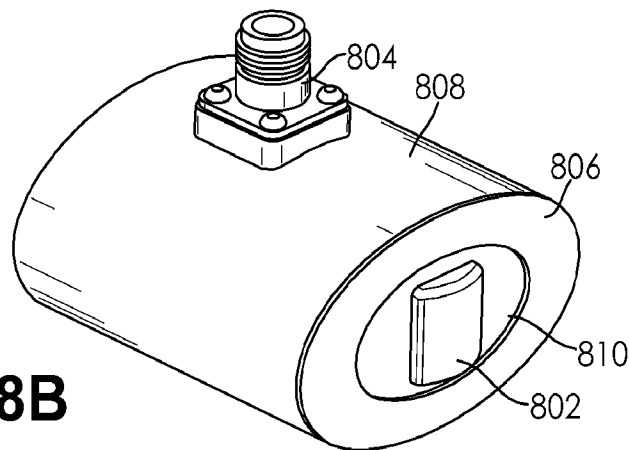

FIG. 8B

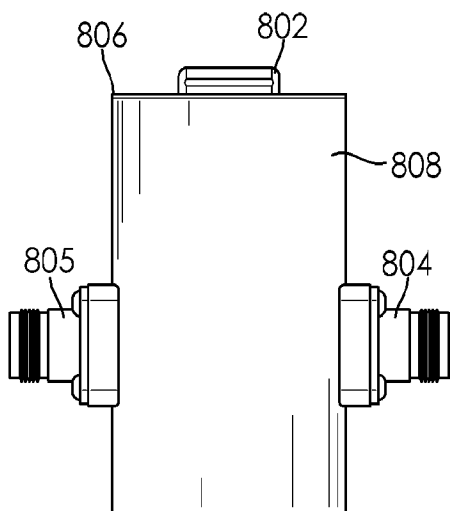

FIG. 8C

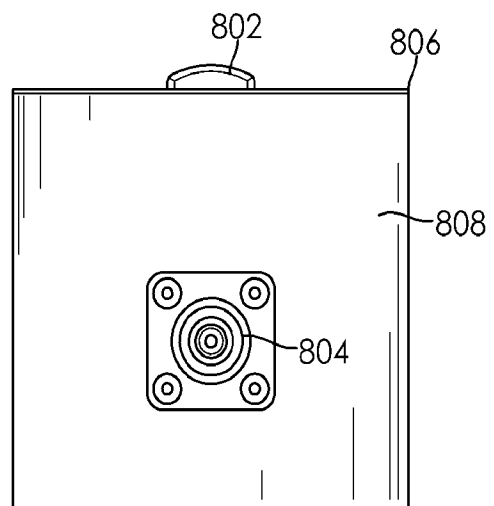

FIG. 8D

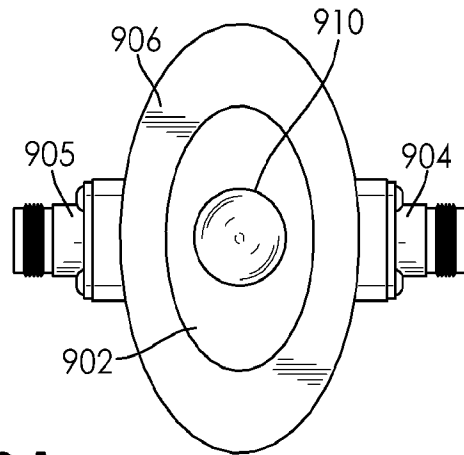

FIG. 9A

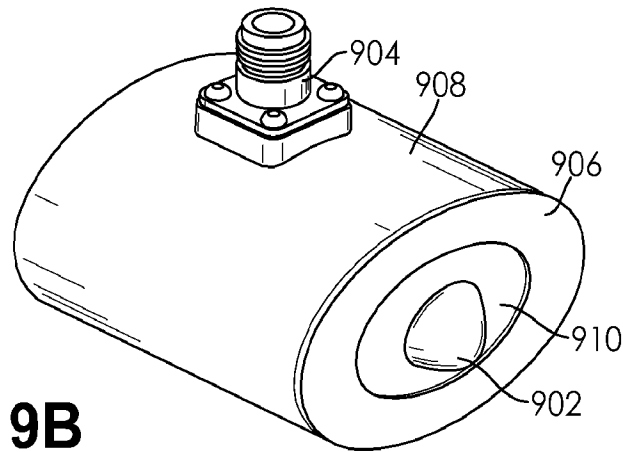

FIG. 9B

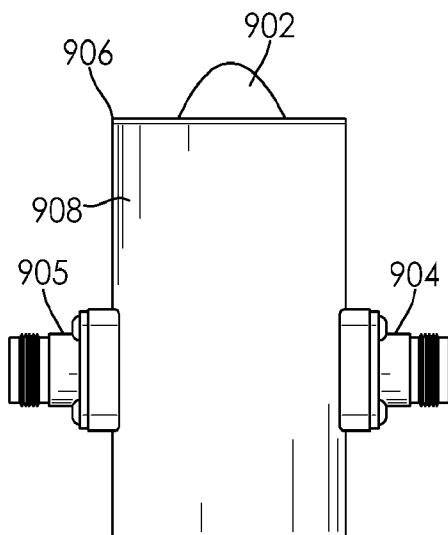

FIG. 9C

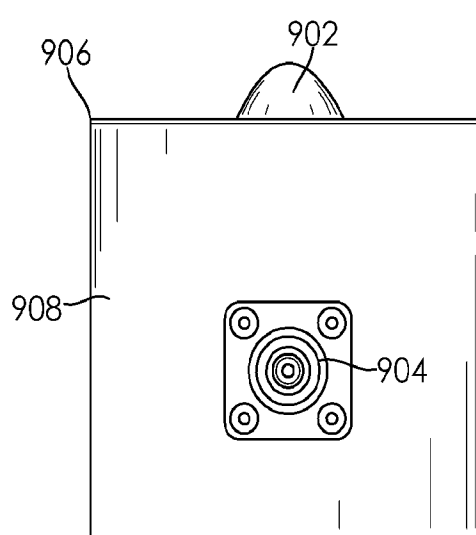

FIG. 9D

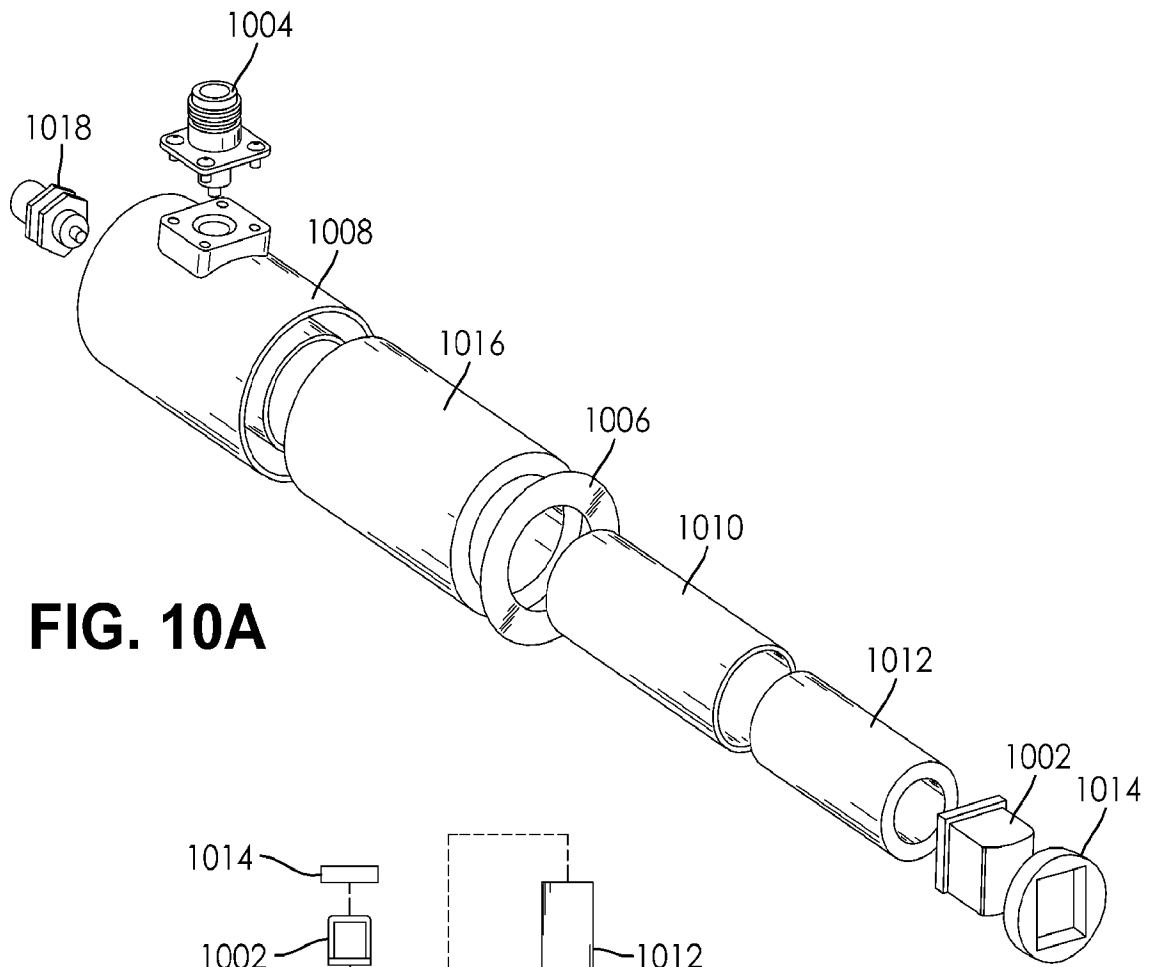

FIG. 10A

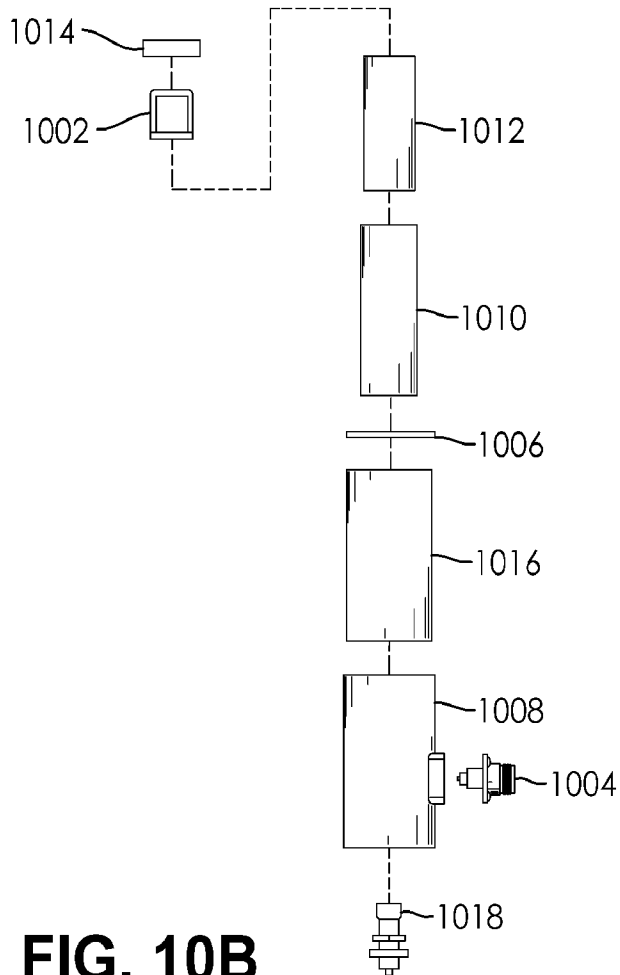

FIG. 10B

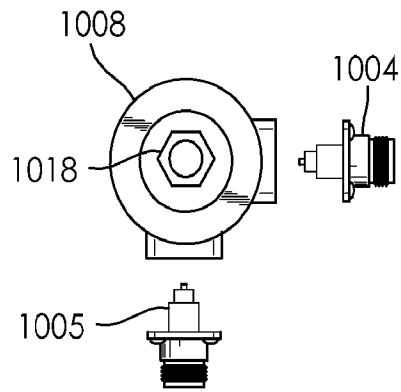
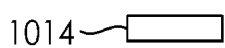
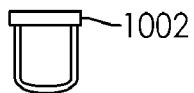
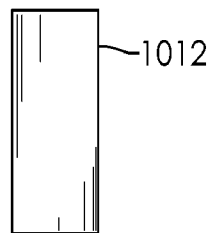
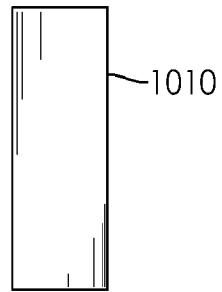
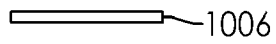
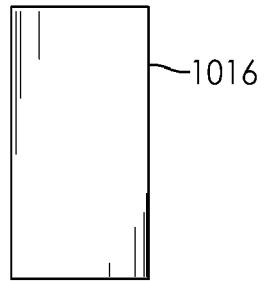
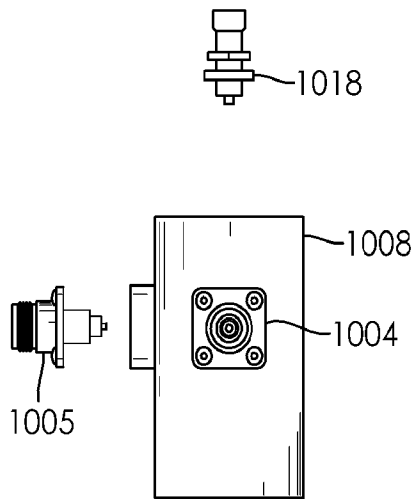

FIG. 10D

FIG. 10C

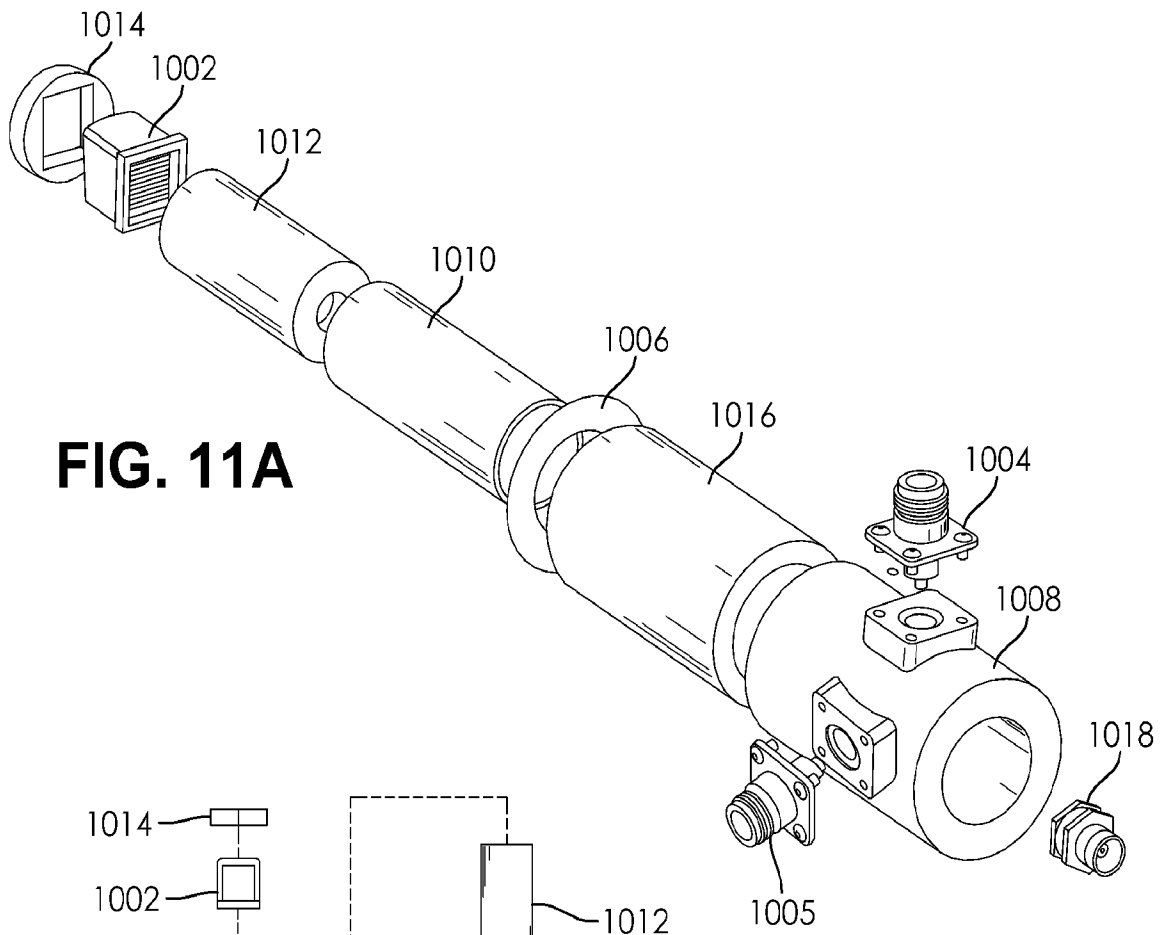

FIG. 11A

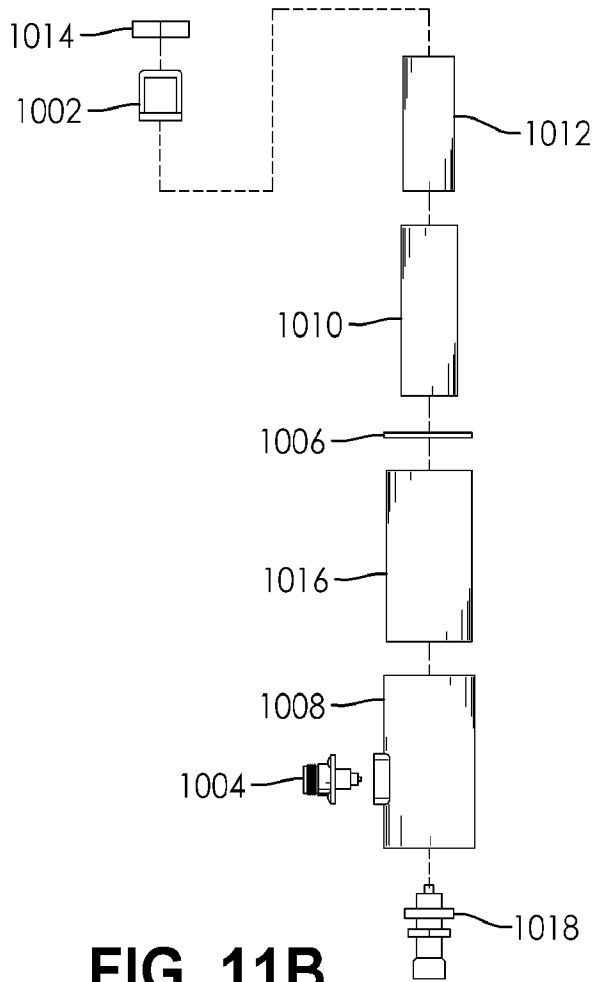

FIG. 11B

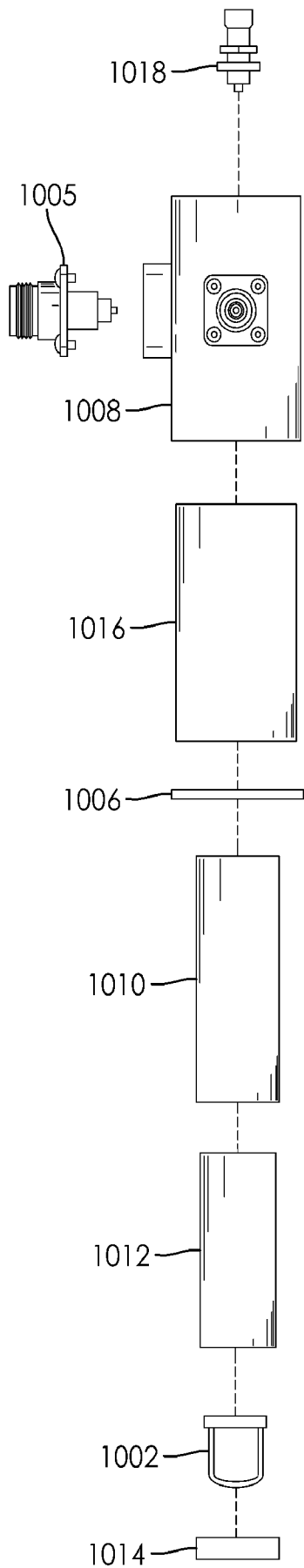

FIG. 11D

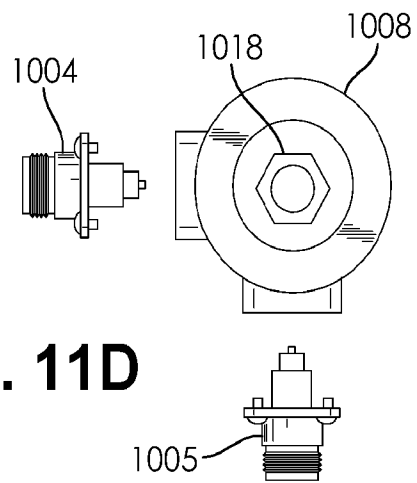

FIG. 11C

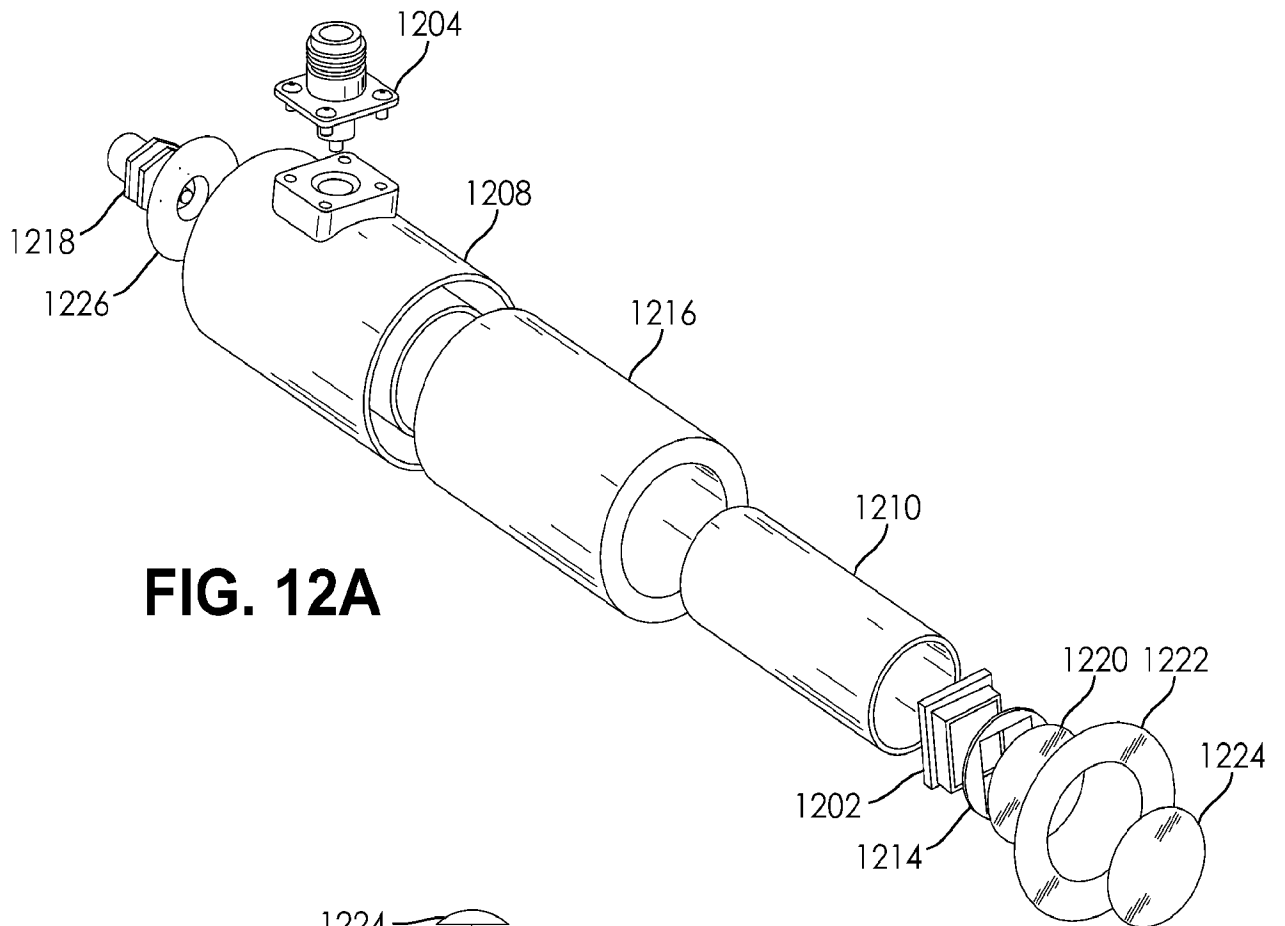

FIG. 12A

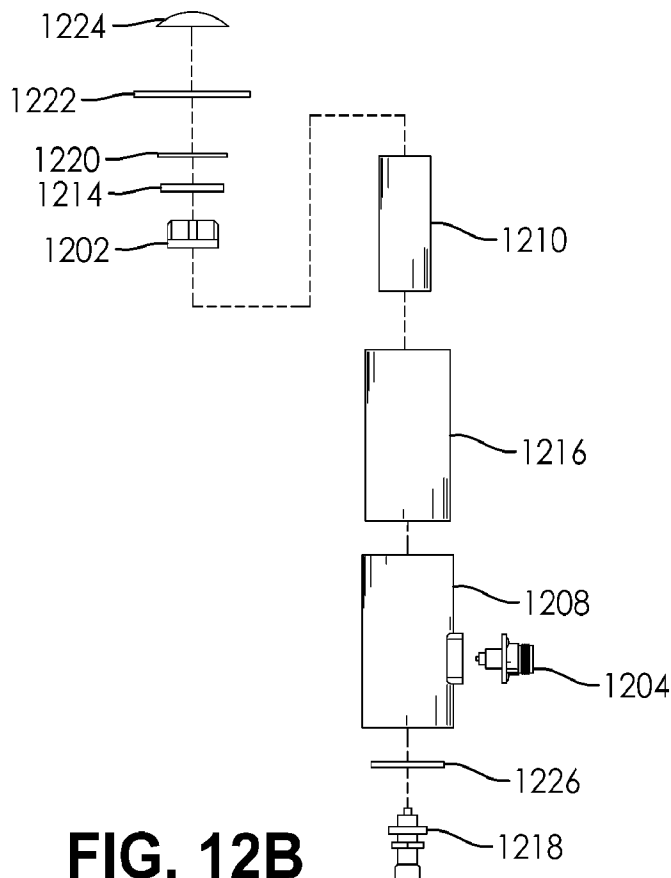

FIG. 12B

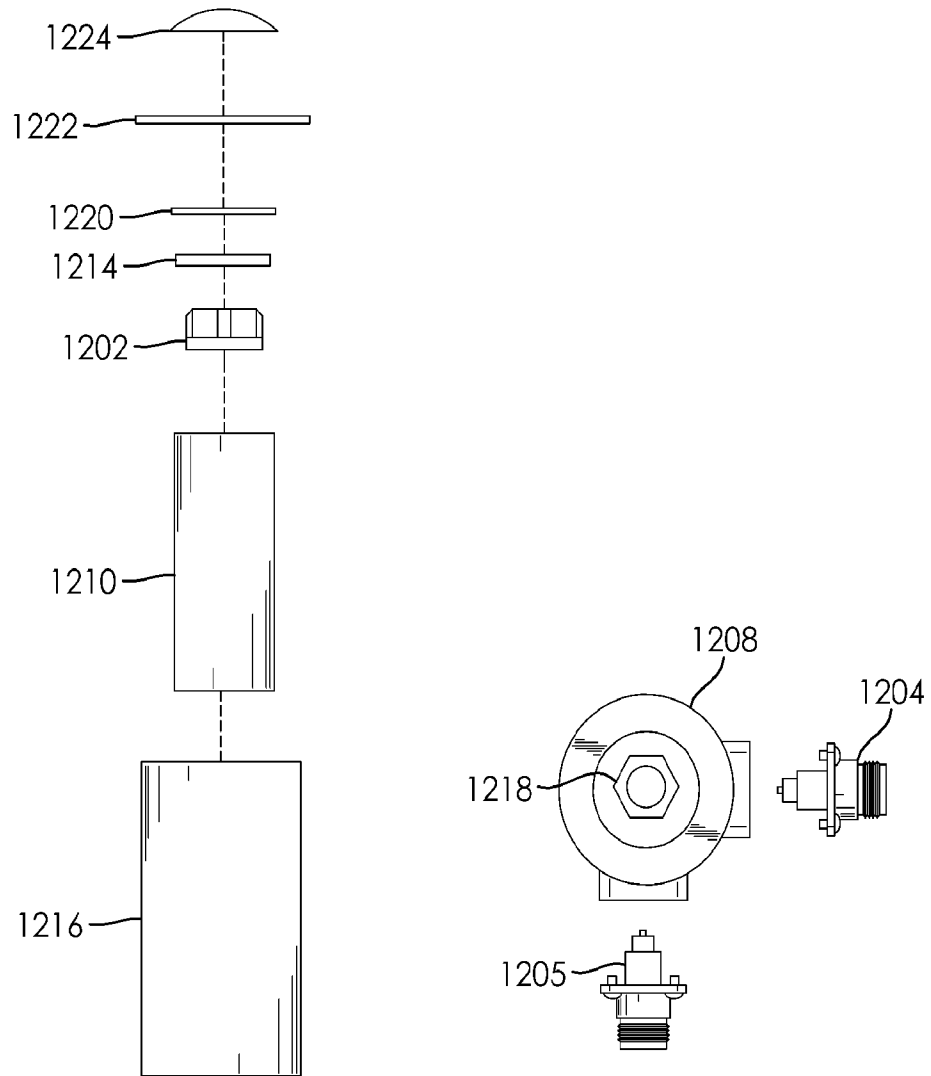

FIG. 12D

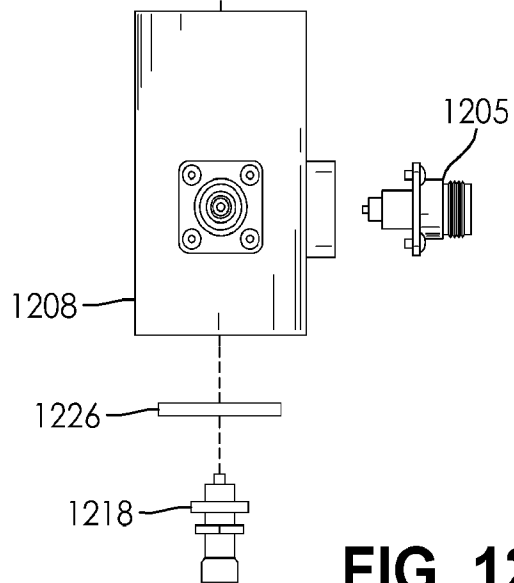

FIG. 12C

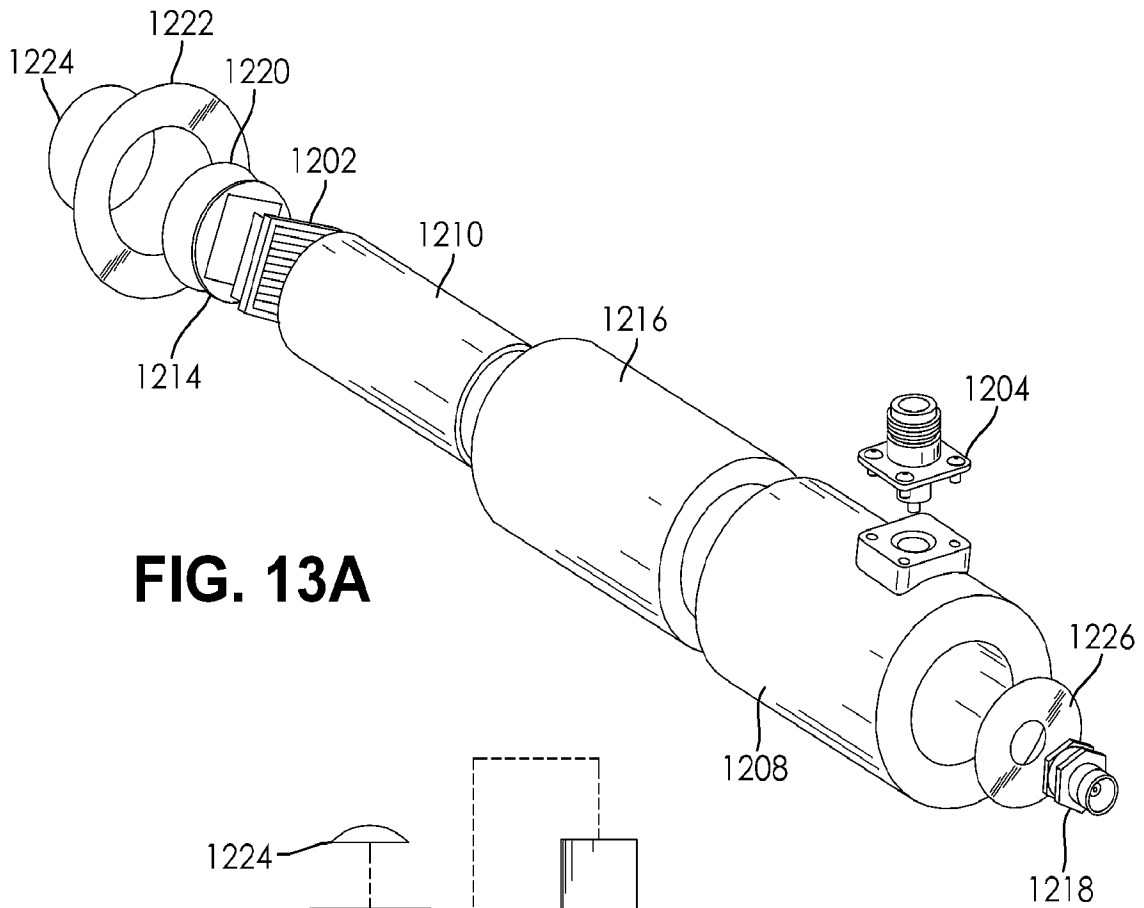

FIG. 13A

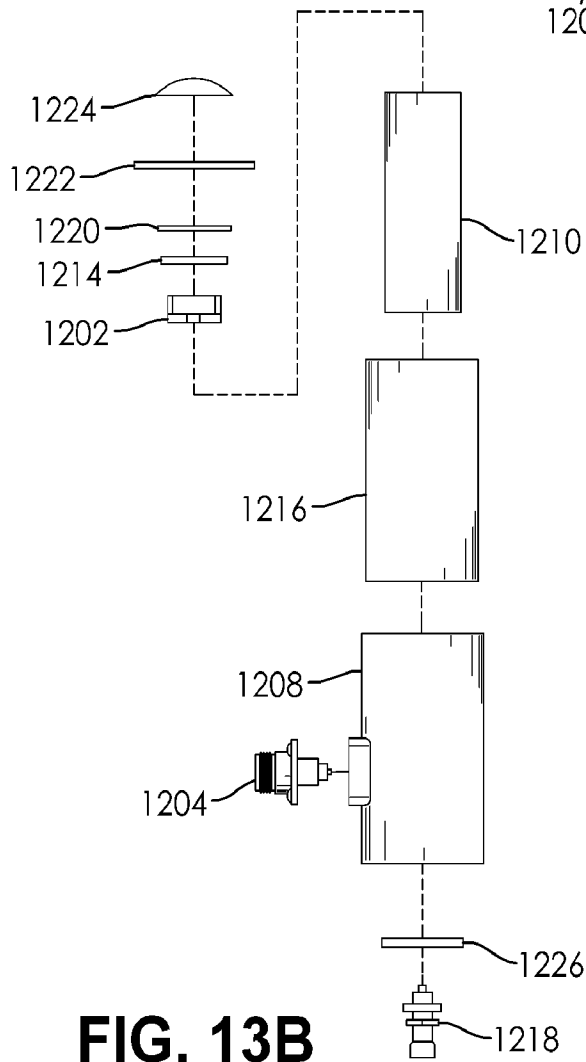

FIG. 13B

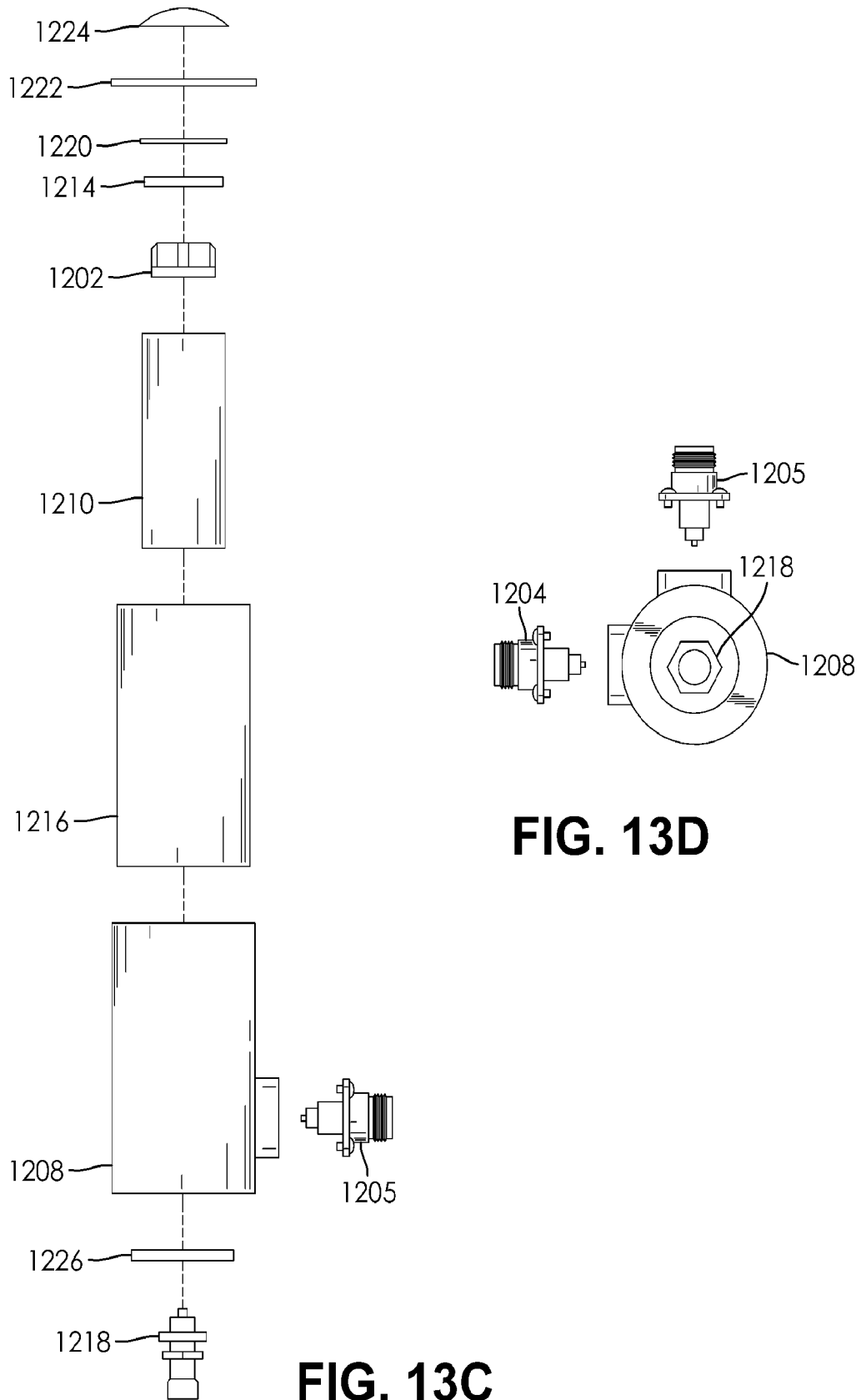

FIG. 13D

FIG. 13C

17/37

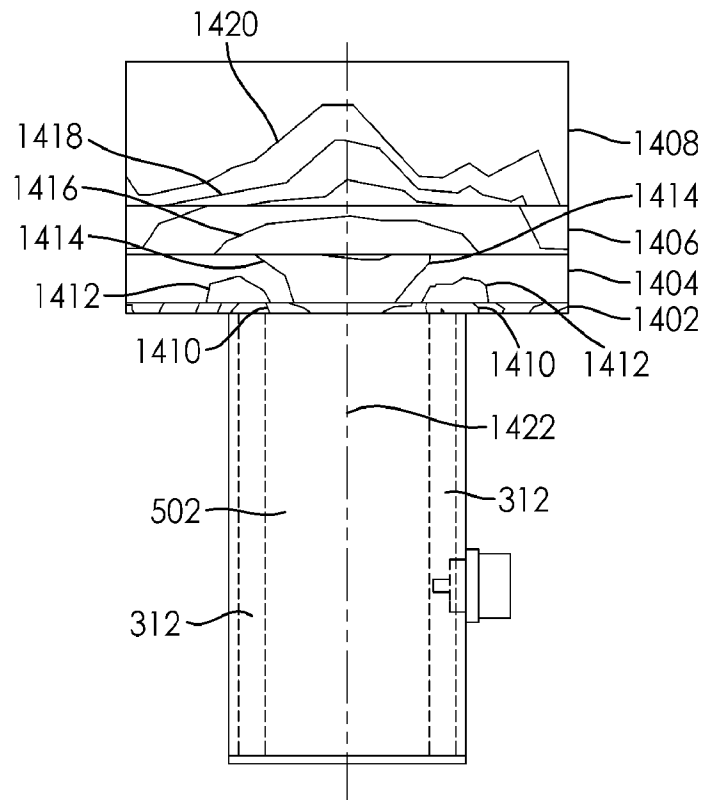

FIG. 14

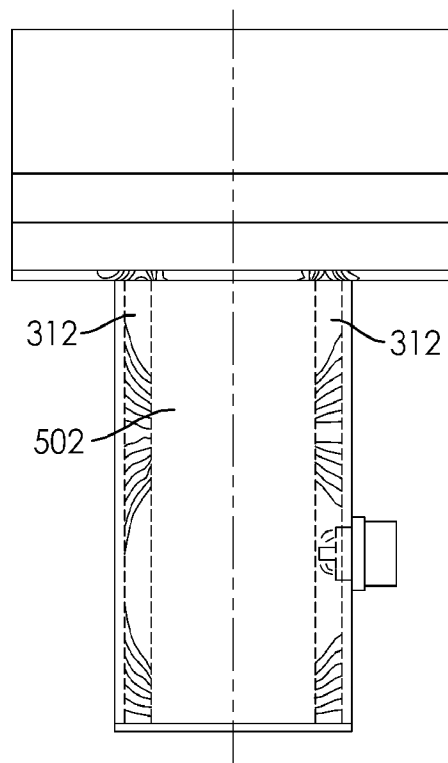

FIG. 15

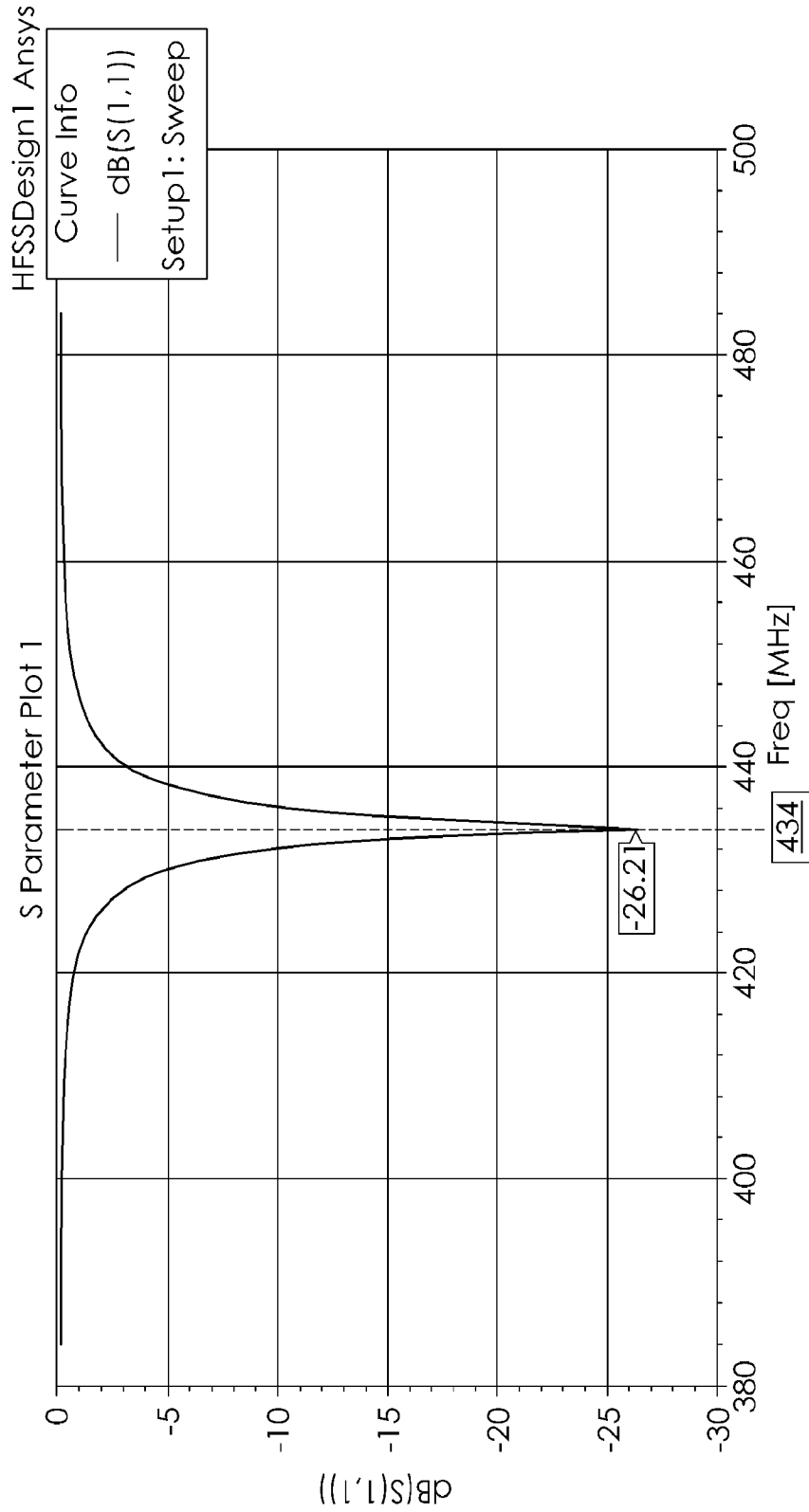

FIG. 16

0° phase port1, 0° phase port 2
0% power port 1, 100% power
port 2

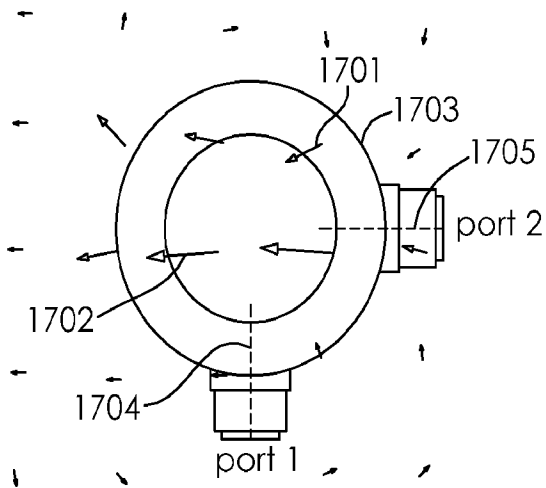

FIG. 17

0° phase port1, 0° phase port 2
50% power port 1, 50% power
port 2

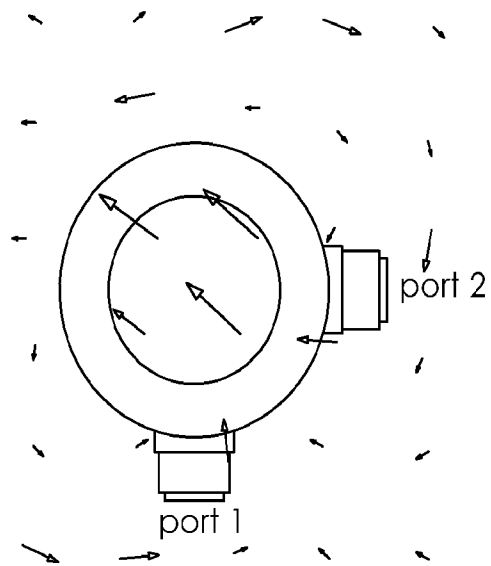

FIG. 18

0° phase port1, 0° phase port 2
100% power port 1, 0% power
port 2

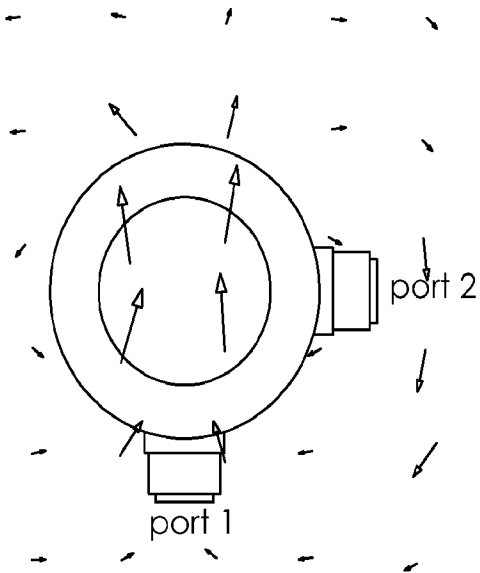

FIG. 19

0° phase port1, 180° phase port 2
100% power port 1, 0% power
port 2

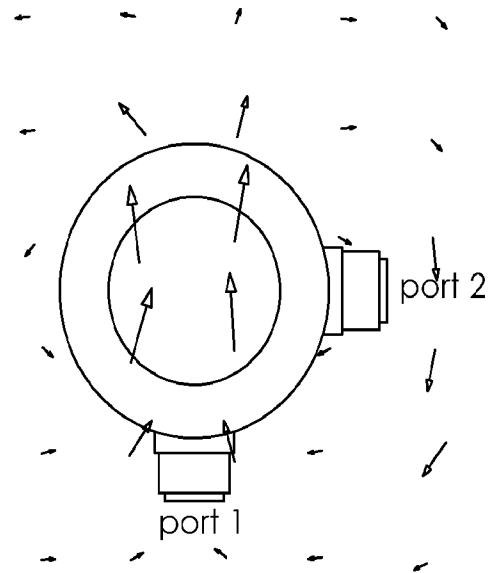

FIG. 20

0° phase port1, 180° phase port 2
50% power port 1, 50% power
port 2

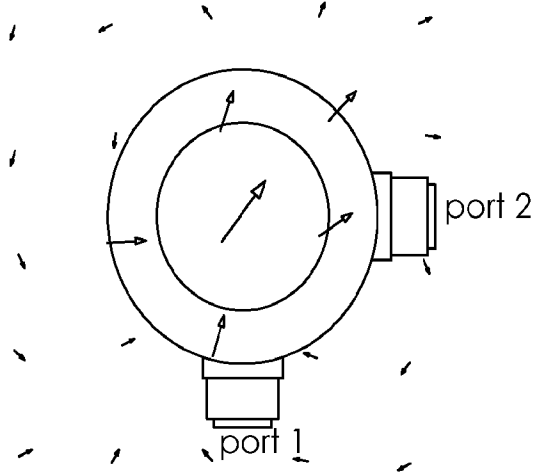

FIG. 21

0° phase port1, 180° phase port 2
0% power port 1, 100% power
port 2

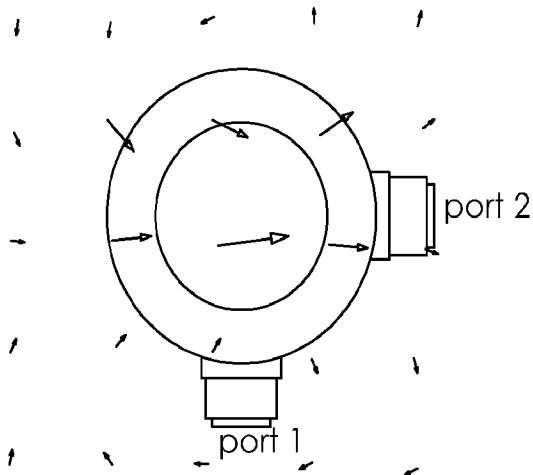

FIG. 22

180° phase port1, 180° phase port 2
0% power port 1, 100% power
port 2

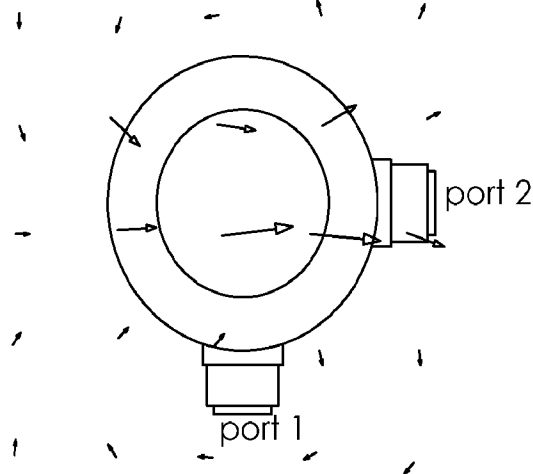

FIG. 23

180° phase port1, 180° phase port 2
50% power port 1, 50% power
port 2

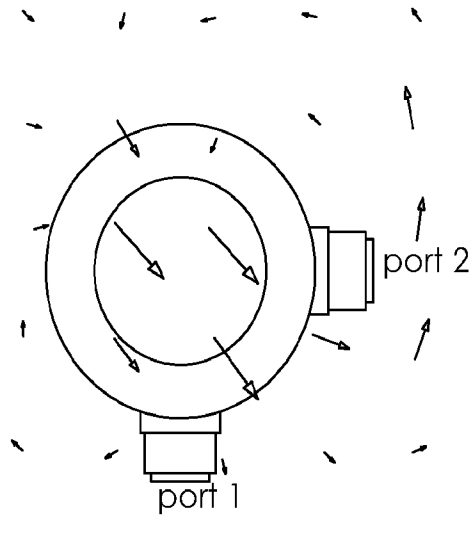

FIG. 24

180° phase port1, 180° phase port 2
100% power port 1, 0% power
port 2

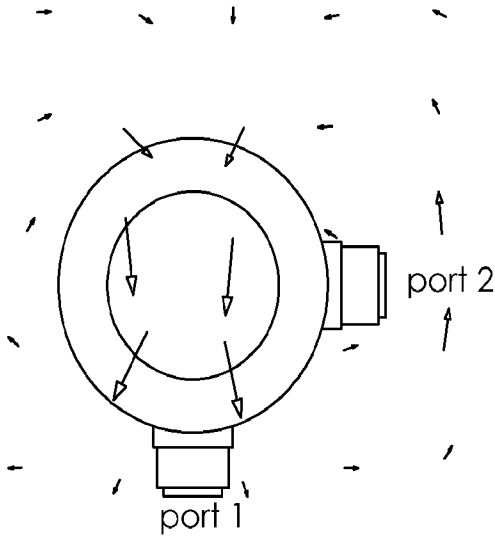

FIG. 25

180° phase port1, 0° phase port 2
100% power port 1, 0% power
port 2

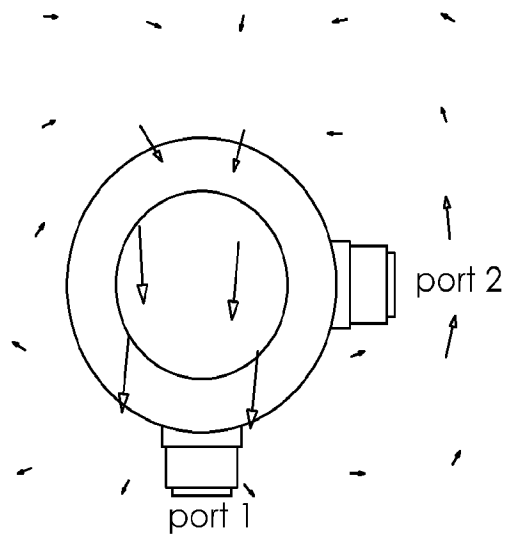

FIG. 26

180° phase port1, 0° phase port 2
50% power port 1, 50% power
port 2

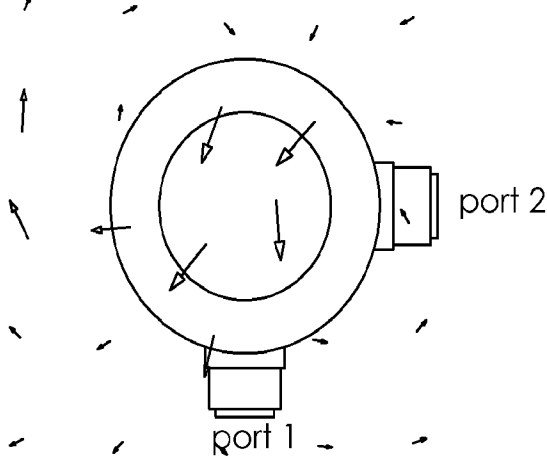

FIG. 27

180° phase port1, 0° phase port 2
0% power port 1, 100% power
port 2

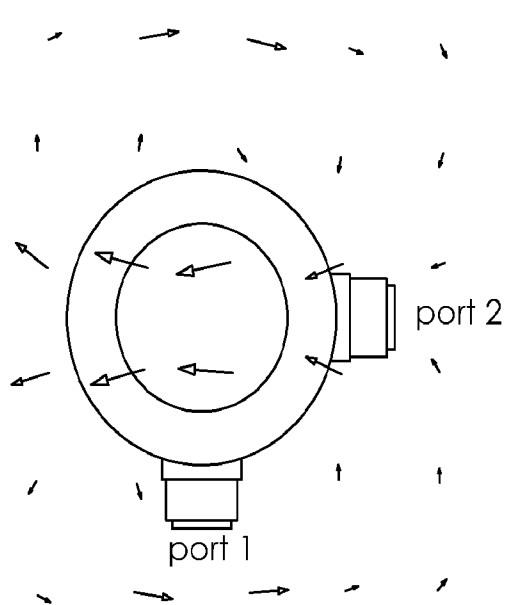

FIG. 28

0° phase port1, 90° phase port 2
50% power port 1, 50% power
port 2

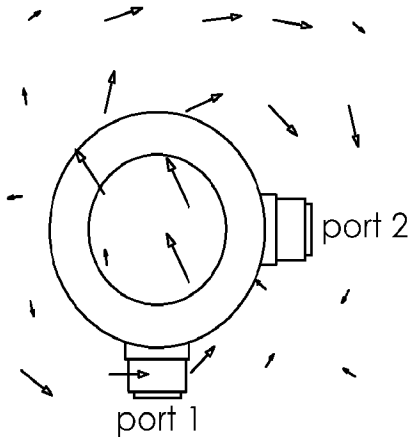

FIG. 29A

0° phase port1, 90° phase port 2
50% power port 1, 50% power
port 2

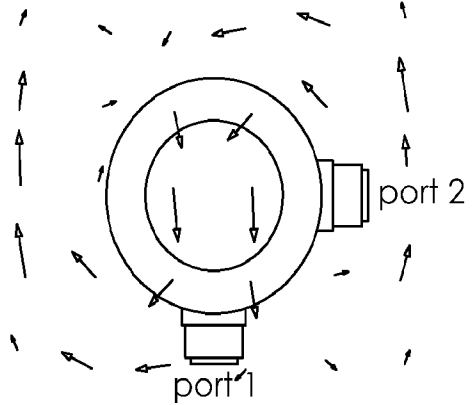

FIG. 29D

0° phase port1, 90° phase port 2
50% power port 1, 50% power
port 2 phase

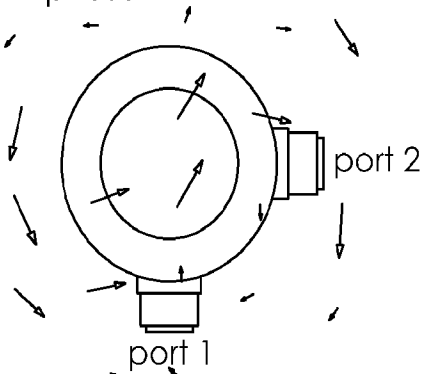

FIG. 29B

0° phase port1, 90° phase port 2
50% power port 1, 50% power
port 2

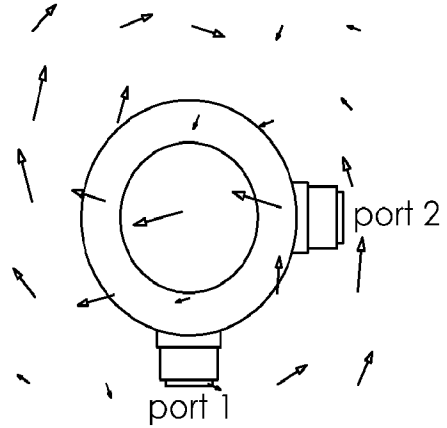

FIG. 29E

0° phase port1, 90° phase port 2
50% power port 1, 50% power
port 2

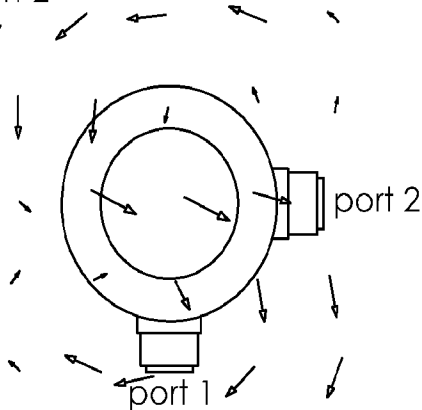

FIG. 29C

0° phase port1, 90° phase port 2
50% power port 1, 50% power
port 2

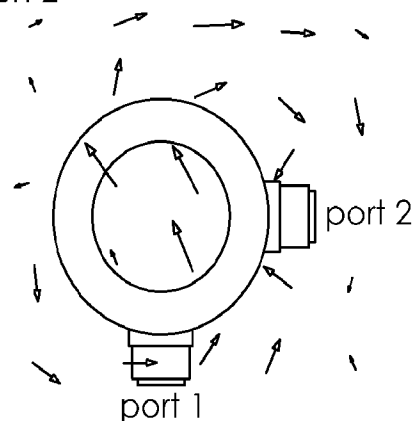

FIG. 29F

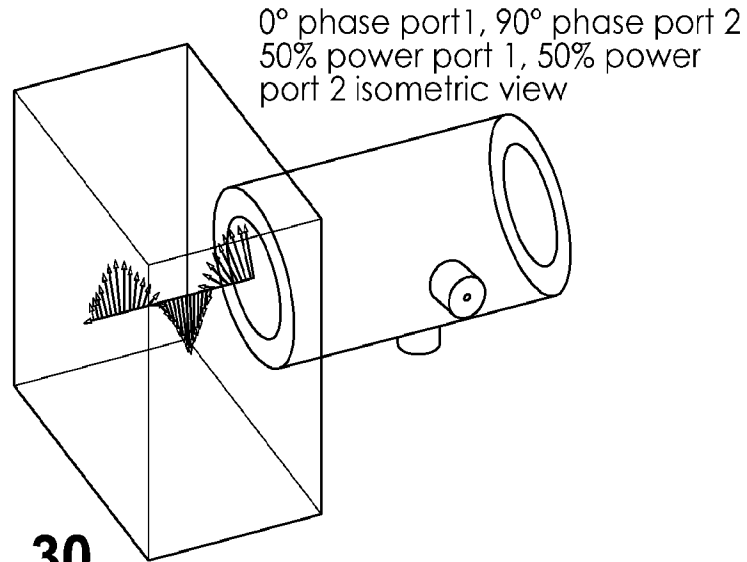

FIG. 30

0° phase port1, 90° phase port 2
50% power port 1, 50% power
port 2 side view

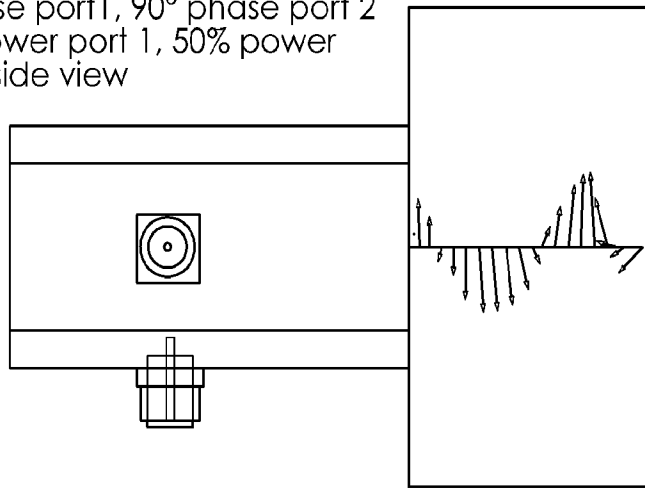

FIG. 31

0mm 20mm 40mm

0° phase port1, 0° phase port 2
0% power port 1, 100% power
port 2

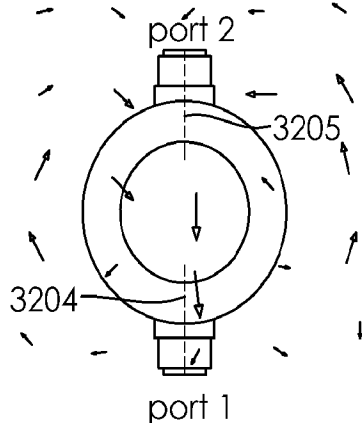

FIG. 32

0° phase port1, 0° phase port 2
50% power port 1, 50% power
port 2

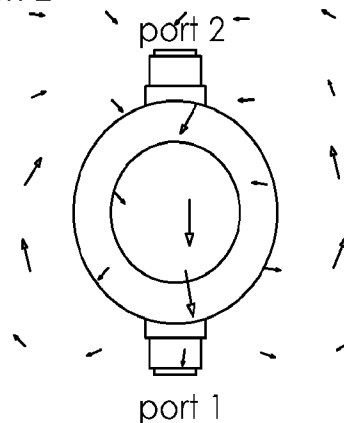

FIG. 33

0° phase port 1, 0° phase port 2
100% power port 1, 0% power port 2

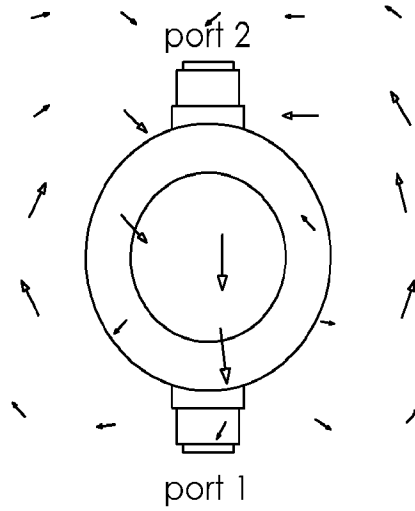

FIG. 34

0° phase port 1, 180° phase port 2
100% power port 1, 0% power port 2

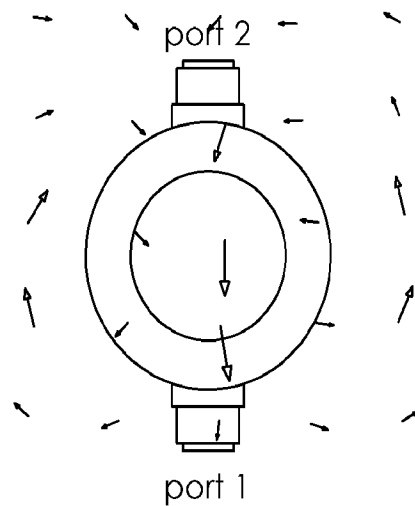

FIG. 35

0° phase port1, 180° phase port 2
50% power port 1, 50% power
port 2

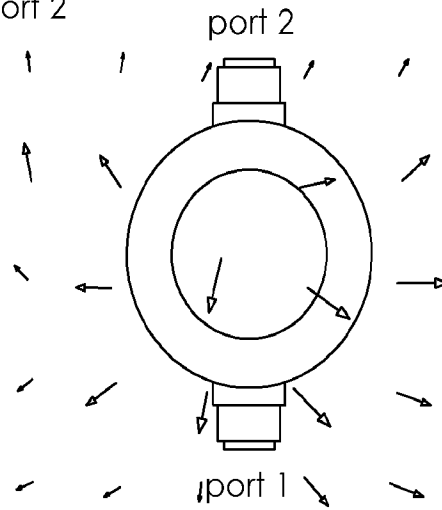

FIG. 36

0° phase port1, 180° phase port 2
100% power port 1, 100% power
port 2

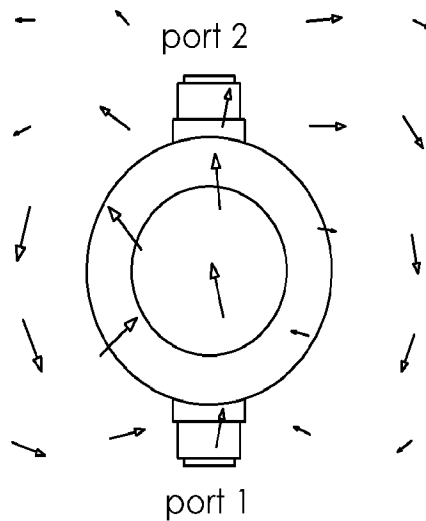

FIG. 37

180° phase port 1, 180° phase port 2
0% power port 1, 100% power port 2

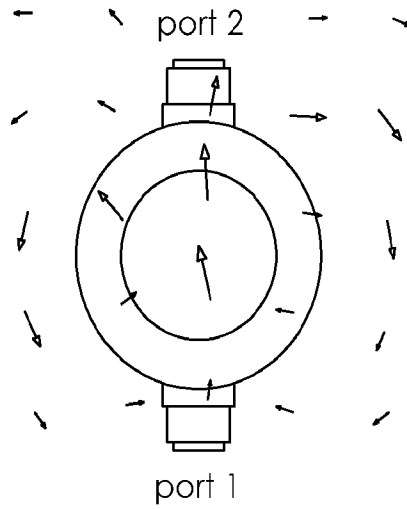

FIG. 38

180° phase port 1, 180° phase port 2
50% power port 1, 50% power port 2

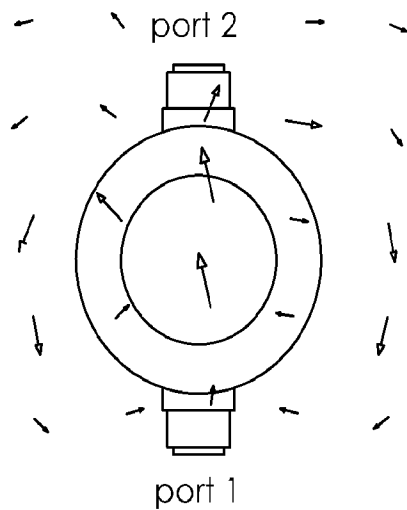

FIG. 39

180° phase port1, 180° phase port 2
100% power port 1, 0% power
port 2

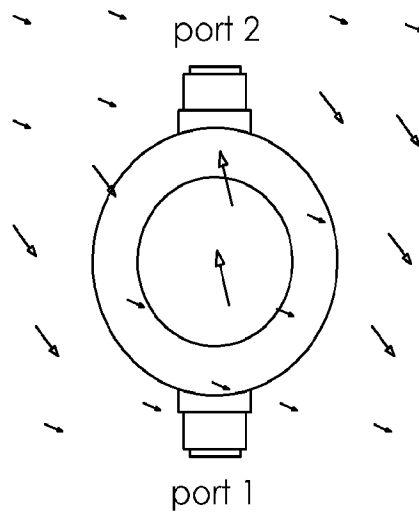

FIG. 40

180° phase port1, 0° phase port 2
100% power port 1, 0% power
port 2

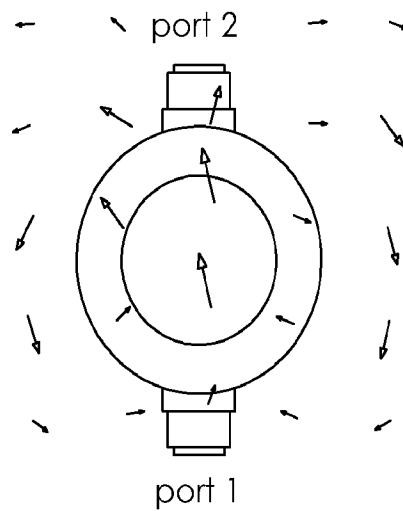

FIG. 41

180° phase port1, 0° phase port 2
 50% power port 1, 50% power
 port 2

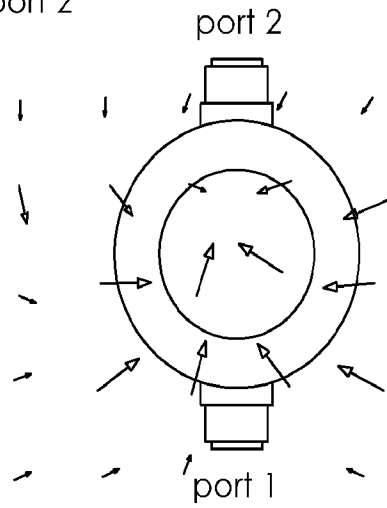

FIG. 42

180° phase port1, 0° phase port 2
 0% power port 1, 100% power
 port 2

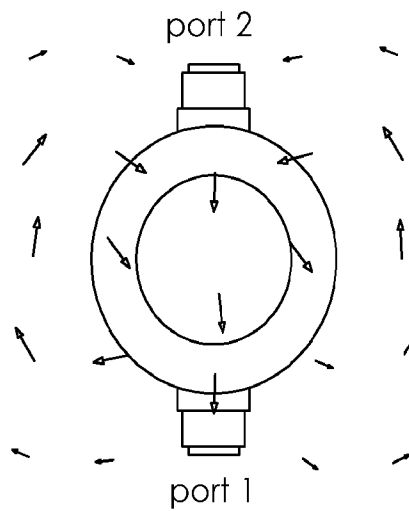

FIG. 43

0° phase port 1, 90° phase port 2
50% power port 1, 50% power
port 2

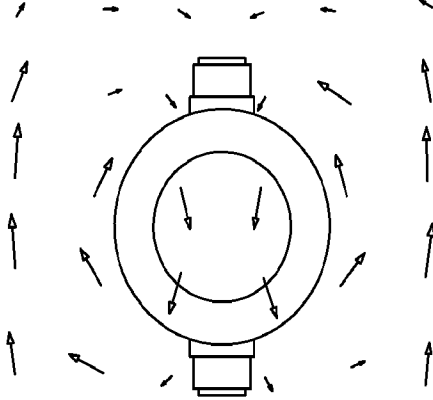

FIG. 44A

0° phase port 1, 90° phase port 2
50% power port 1, 50% power
port 2

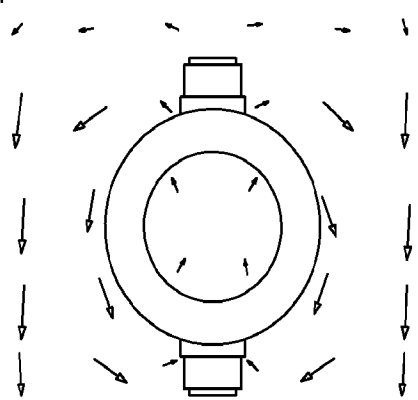

FIG. 44D

0° phase port 1, 90° phase port 2
50% power port 1, 50% power
port 2

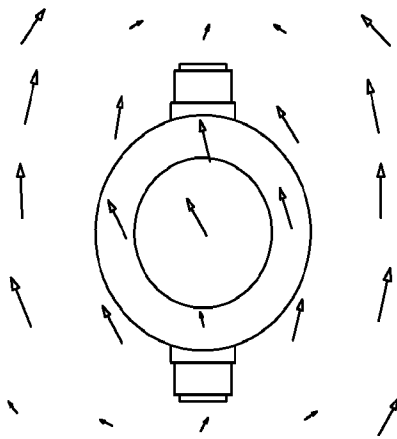

FIG. 44B

0° phase port 1, 90° phase port 2
50% power port 1, 50% power
port 2

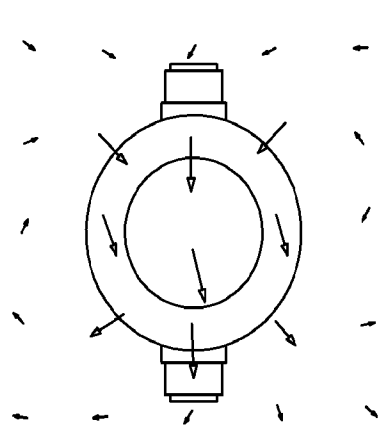

FIG. 44E

0° phase port 1, 90° phase port 2
50% power port 1, 50% power
port 2

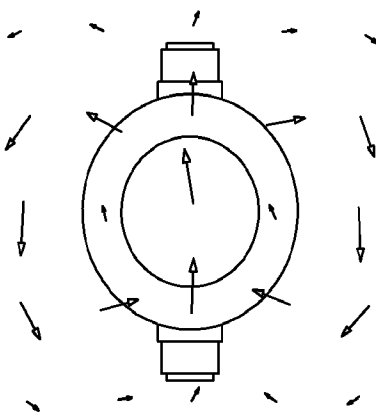

FIG. 44C

0° phase port 1, 90° phase port 2
50% power port 1, 50% power
port 2

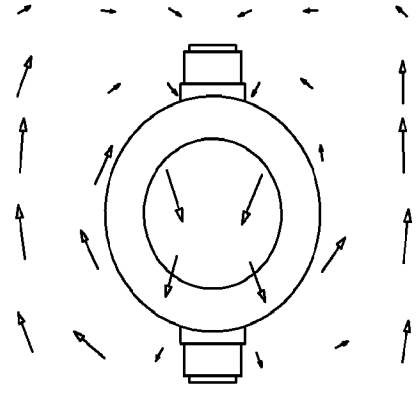

FIG. 44F

30/37

0° phase port 1, 90° phase port 2
50% power port 1, 50% power
port 2 isometric view

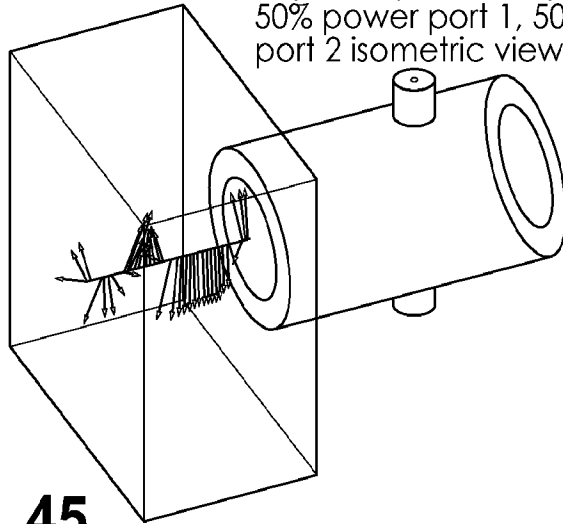
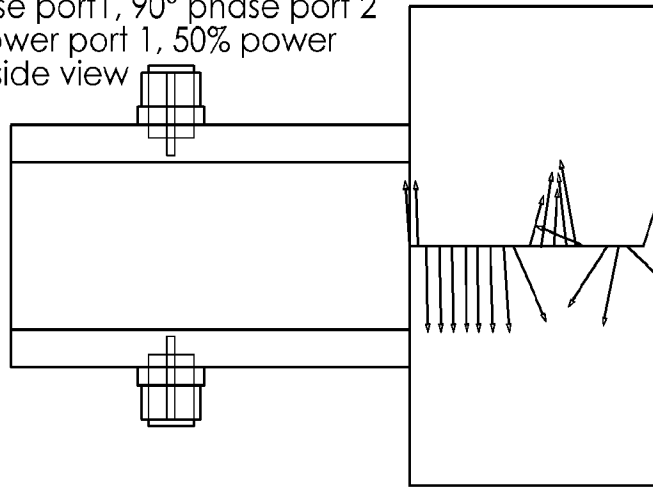

FIG. 45

0° phase port 1, 90° phase port 2
50% power port 1, 50% power
port 2 side view



0mm 20mm 40mm

FIG. 46

0° phase port 1, 90° phase port 2
0% power port 1, 100% power
port 2

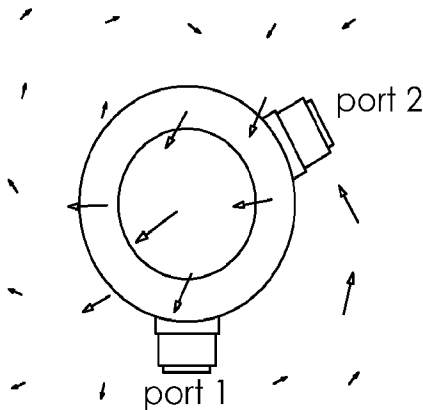

FIG. 47

0° phase port 1, 0° phase port 2
50% power port 1, 50% power
port 2

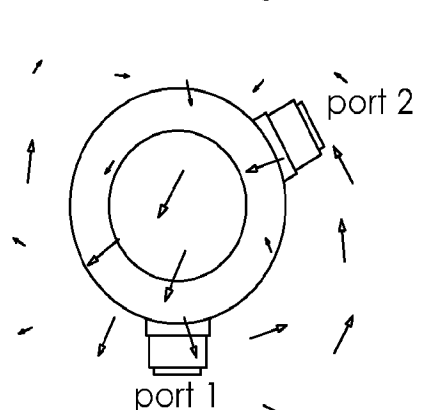

FIG. 48

0° phase port 1, 0° phase port 2
 100% power port 1, 0% power
 port 2

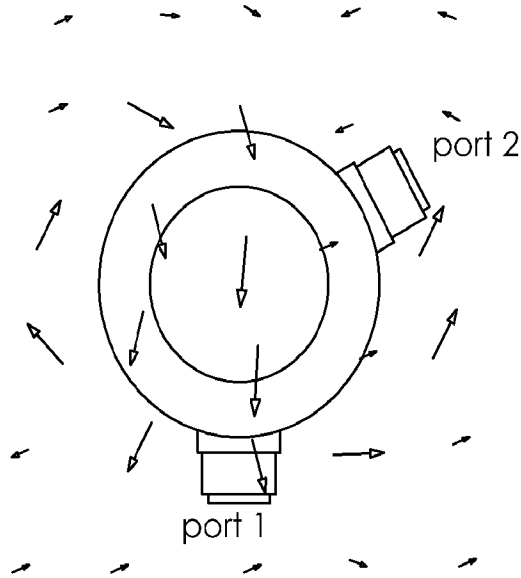

FIG. 49

0° phase port 1, 180° phase port 2
 100% power port 1, 0% power
 port 2

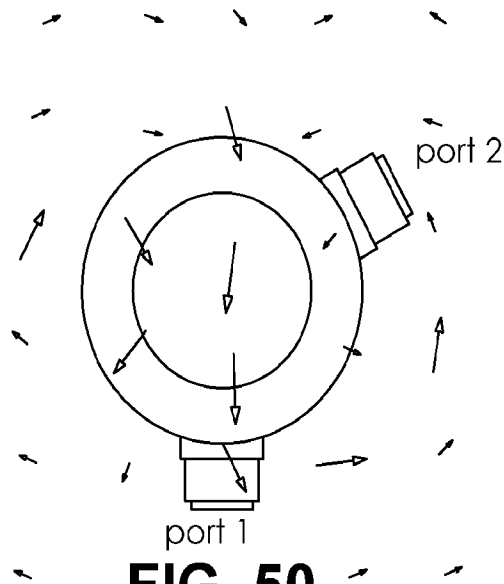

FIG. 50

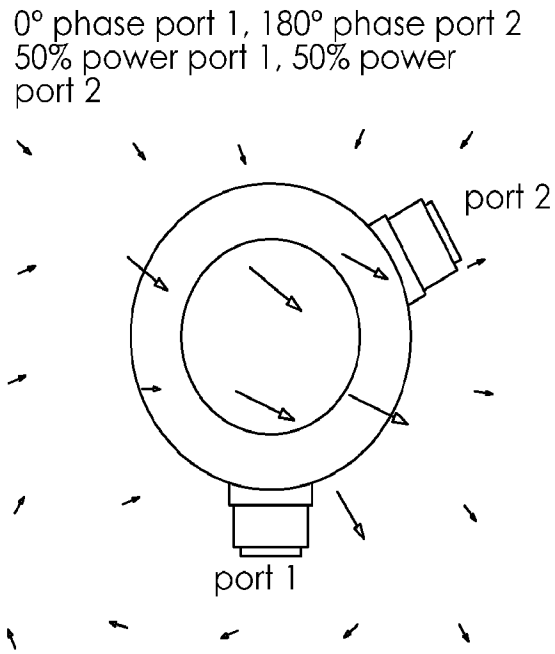

FIG. 51

0° phase port 1, 180° phase port 2
0% power port 1, 100% power port 2

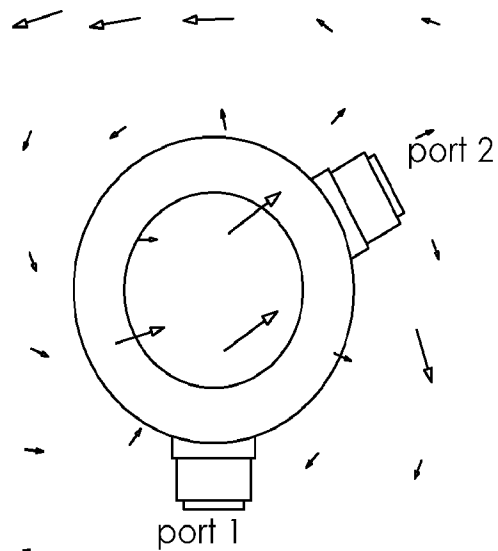

FIG. 52

180° phase port 1, 180° phase port 2
0% power port 1, 100% power port 2

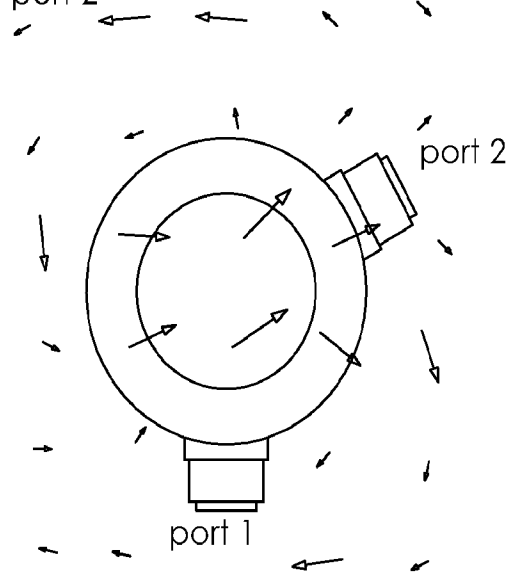

FIG. 53

180° phase port 1, 180° phase port 2
50% power port 1, 50% power port 2

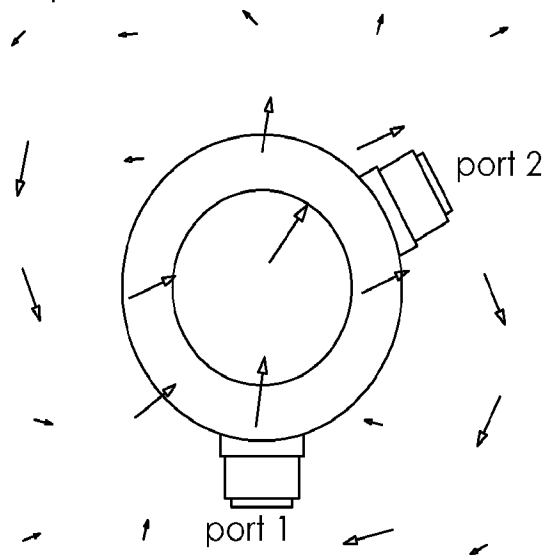

FIG. 54

180° phase port 1, 180° phase port 2
100% power port 1, 0% power
port 2

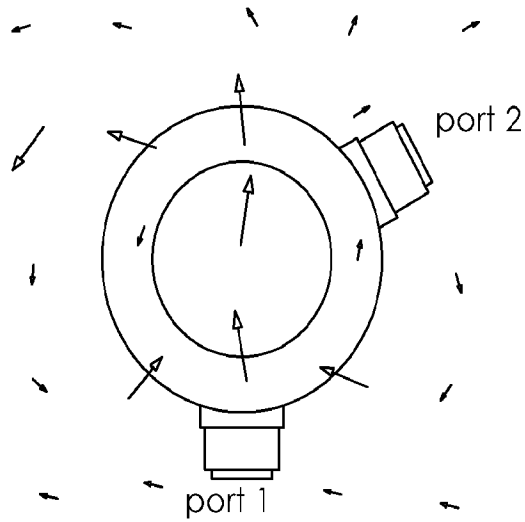

FIG. 55

180° phase port 1, 0° phase port 2
100% power port 1, 0% power
port 2

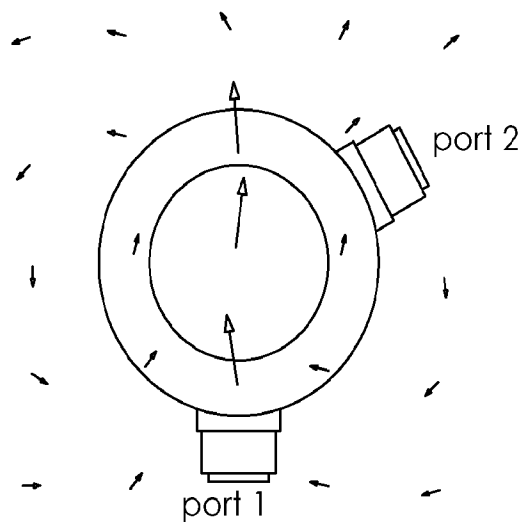

FIG. 56

180° phase port 1, 0° phase port 2
 50% power port 1, 50% power
 port 2

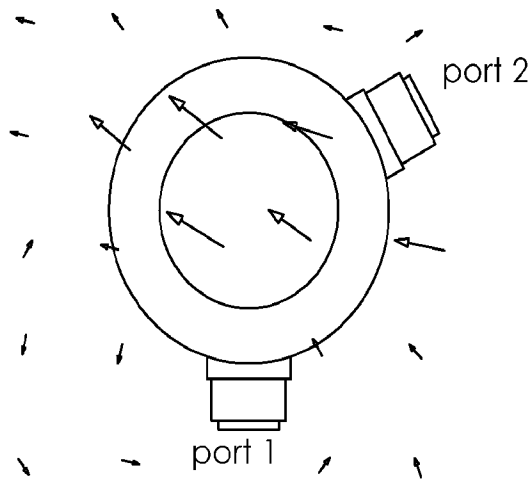

FIG. 57

180° phase port 1, 0° phase port 2
 0% power port 1, 100% power
 port 2

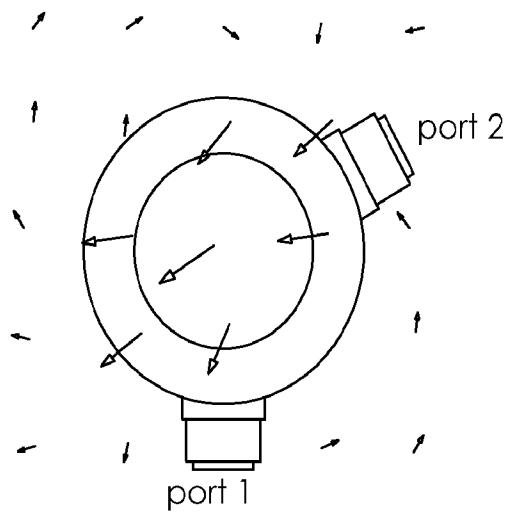

FIG. 58

0° phase port 1, 90° phase port 2
50% power port 1, 50% power
port 2

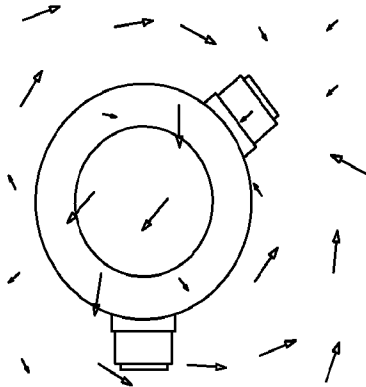

FIG. 59A

0° phase port 1, 90° phase port 2
50% power port 1, 50% power
port 2

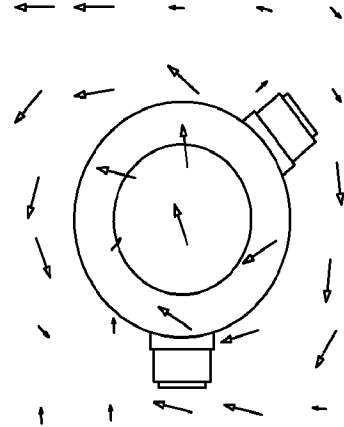

FIG. 59D

0° phase port 1, 90° phase port 2
50% power port 1, 50% power
port 2

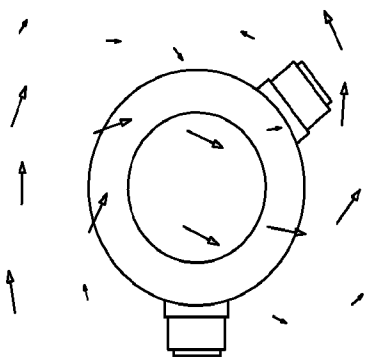

FIG. 59B

0° phase port 1, 90° phase port 2
50% power port 1, 50% power
port 2

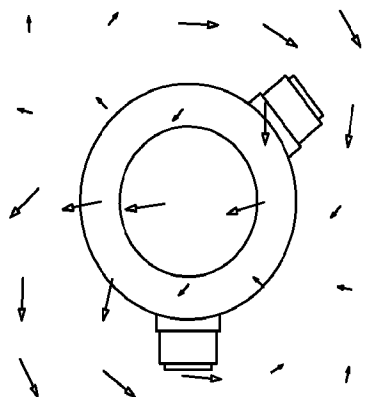

FIG. 59E

0° phase port 1, 90° phase port 2
50% power port 1, 50% power
port 2

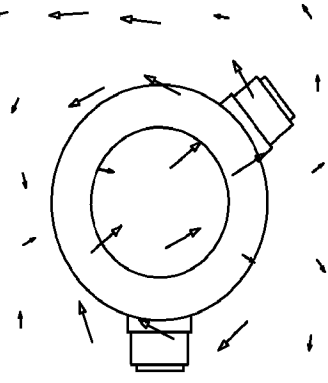

FIG. 59C

0° phase port 1, 90° phase port 2
50% power port 1, 50% power
port 2

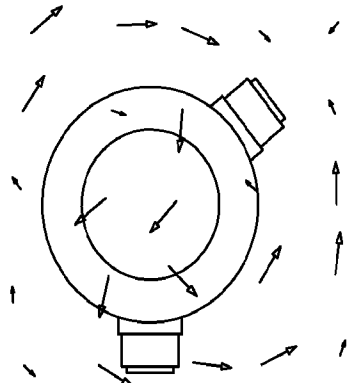

FIG. 59F

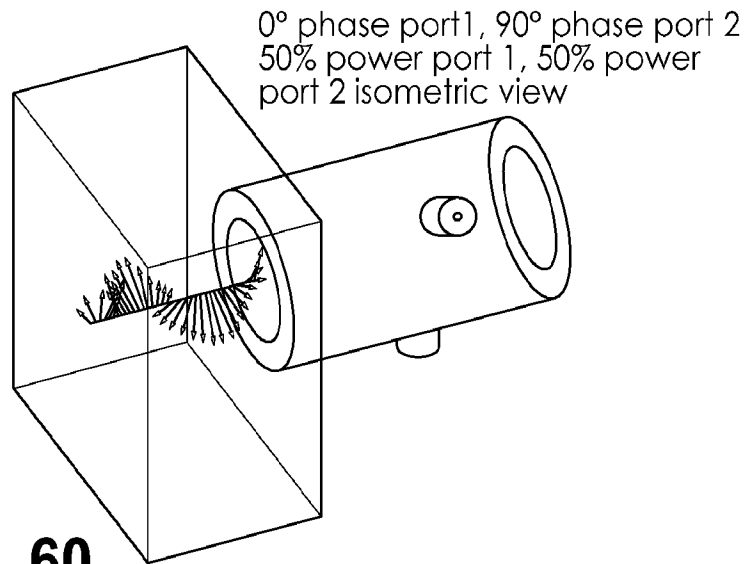

FIG. 60

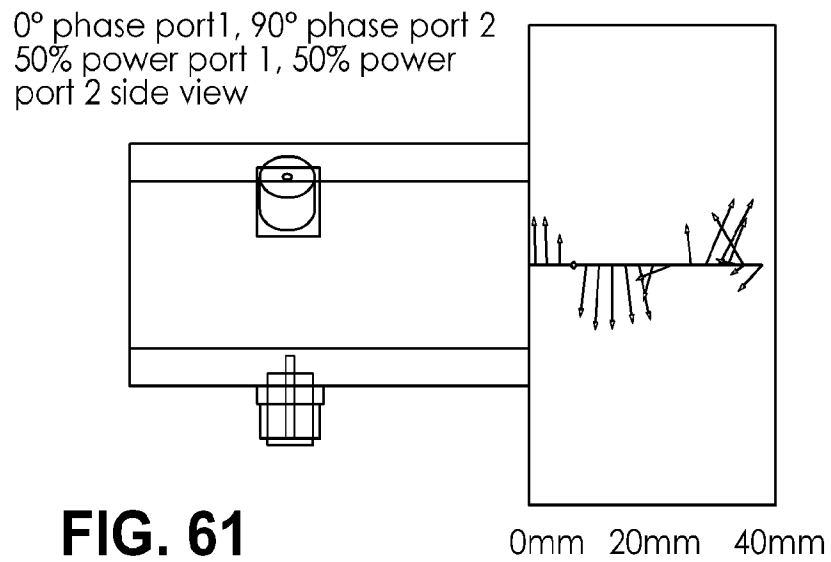

FIG. 61

INTERNATIONAL SEARCH REPORT

International application No.

PCT/US2024/021952

A. CLASSIFICATION OF SUBJECT MATTER		
IPC: A61B 8/08 (2023.01); G01N 29/04 (2023.01); G01N 29/06 (2023.01); G01N 29/24 (2023.01); G02F 1/225 (2023.01) CPC: A61B 8/08 ; G01N 29/04 ; G01N 29/06 ; G01N 29/24 ; G02F 1/225 ; A61B 8/08 ; G01N 29/04 ; G01N 29/06 ; G01N 29/24 ; G02F 1/225		
According to International Patent Classification (IPC) or to both national classification and IPC		
B. FIELDS SEARCHED		
Minimum documentation searched (classification system followed by classification symbols) A61B 8/08; G01N 29/04, 29/06, 29/24; G02F 1/225/IPC: A61B 8/08; G01N 29/04, 29/06, 29/24; G02F 1/225		
Documentation searched other than minimum documentation to the extent that such documents are included in the fields searched		
Electronic data base consulted during the international search (name of data base and, where practicable, search terms used) US-PGPUB; USPAT; USOCR; FIT; AU, AP, AT, BE, BG, BR, BY, CA, CH, CN, CS, CU, CZ, DD, DE, DK, EA, EE, EP, ES, FI, FR, GB, HR, HU, ID, IE, IL, IS, IT, JP, KR, LT, LU, LV, MA, OA, RU, SU, WO: Intelligence, with, Similar, Text, doc, and, Artificial, Selections, CPC, near, ENDRA, did, LIFE, INC, SCIENCES, OR, DUKE, detecting, gauge, UNIVERSITY, AS, DAVIS, AANM, Christopher, MACCARINI, Paolo, STEINBERG, Idan, THORNTON, Michael, INV, thermoacoustic, acoustic, implant, set, nano, SAME, photo, thermo, probe, electro, photon, ADJ, absorption, Golay, cell, photoacoustic, opto, electroacoustic, thermoelectric, electric, radio, SWG, neurophotonic, neuro, photonic, sensor, thermal, microsensor, transducer, sensing, detector, gage, nanosensor, frequency, RF, WITH, guide, in, AWG, position, interject, waveguide, feed, annular, passage, wave, cavity, hole, trench, groove, hollow, concavity, opening, recess, channel, passage, dispose, insert, embed, inject, encapsulate, inward, core, enter, inside, surround, clm, within, interior, nest, inner, sleeve, encircle, absorption, probe, transducer, PZT, subassembly, concavity, detector, cylindrical, neck, tube, profile, band, tubelike, jacket, ring, wedge, ringlet, tubular, muffler, damper, piezoceramic, ceramic, piezoelectric, noise, sound, reduce, sonic, PE, PVF, stop, cancel, attenuate, isolate, suppress, damping, denois, dampening, pn, meter, nanosensor, pickup, device, system, pick, assembly, up, cylinder, tubular, cpc, probe, detector, micro, transponder, sensing, encircle, SWG, AWG, tube, remove, recess		
C. DOCUMENTS CONSIDERED TO BE RELEVANT		
Category*	Citation of document, with indication, where appropriate, of the relevant passages	Relevant to claim No.
A	US 11,619,613 B1 (Davis et al.) 04 April 2013 (04.04.2013) See entire documents	1-20
A	US 11,304,606 B2 (Davis et al.) 19 April 2022 (19.04.2022) See entire documents	1-20
<input checked="" type="checkbox"/> Further documents are listed in the continuation of Box C. <input type="checkbox"/> See patent family annex.		
* Special categories of cited documents: "A" document defining the general state of the art which is not considered to be of particular relevance "D" document cited by the applicant in the international application "E" earlier application or patent but published on or after the international filing date "L" document which may throw doubts on priority claim(s) or which is cited to establish the publication date of another citation or other special reason (as specified) "O" document referring to an oral disclosure, use, exhibition or other means "P" document published prior to the international filing date but later than the priority date claimed "T" later document published after the international filing date or priority date and not in conflict with the application but cited to understand the principle or theory underlying the invention "X" document of particular relevance; the claimed invention cannot be considered novel or cannot be considered to involve an inventive step when the document is taken alone "Y" document of particular relevance; the claimed invention cannot be considered to involve an inventive step when the document is combined with one or more other such documents, such combination being obvious to a person skilled in the art "&" document member of the same patent family		
Date of the actual completion of the international search 06 May 2024 (06.05.2024)		Date of mailing of the international search report 09 May 2024 (09.05.2024)
Name and mailing address of the ISA/US Commissioner for Patents Mail Stop PCT, Attn: ISA/US P.O. Box 1450 Alexandria, VA 22313-1450, United States of America Facsimile No. (571)273-8300		Authorized officer KIM HARRY C. Telephone No. 571-272-4300

INTERNATIONAL SEARCH REPORT

International application No.

PCT/US2024/021952

C. DOCUMENTS CONSIDERED TO BE RELEVANT		
Category*	Citation of document, with indication, where appropriate, of the relevant passages	Relevant to claim No.
A	US 2013/0296683 A1 (Herzog et al.) 07 November 2013 (07.11.2013) See entire documents	1-20
<hr style="border-top: 1px dashed black;"/>		