



US009961397B2

(12) **United States Patent**
Ansari

(10) **Patent No.:** **US 9,961,397 B2**

(45) **Date of Patent:** ***May 1, 2018**

(54) **CENTRALIZED BROADBAND GATEWAY FOR A WIRELESS COMMUNICATION SYSTEM**

(71) Applicant: **AT&T INTELLECTUAL PROPERTY I, L.P.**, Atlanta, GA (US)

(72) Inventor: **Ahmad Ansari**, Austin, TX (US)

(73) Assignee: **AT&T Intellectual Property I, L.P.**, Atlanta, GA (US)

(*) Notice: Subject to any disclaimer, the term of this patent is extended or adjusted under 35 U.S.C. 154(b) by 0 days. days.

This patent is subject to a terminal disclaimer.

(21) Appl. No.: **15/254,632**

(22) Filed: **Sep. 1, 2016**

(65) **Prior Publication Data**
US 2016/0373810 A1 Dec. 22, 2016

Related U.S. Application Data

(63) Continuation of application No. 14/641,977, filed on Mar. 9, 2015, now Pat. No. 9,462,299, which is a (Continued)

(51) **Int. Cl.**
H04N 21/4363 (2011.01)
H04N 21/258 (2011.01)
(Continued)

(52) **U.S. Cl.**
CPC **H04N 21/43637** (2013.01); **H04N 19/90** (2014.11); **H04N 21/258** (2013.01);
(Continued)

(58) **Field of Classification Search**
CPC H04N 21/4367; H04N 21/258; H04N 21/4122; H04N 21/43635; H04N 21/440218; H04N 19/90; H04W 88/16
See application file for complete search history.

(56) **References Cited**
U.S. PATENT DOCUMENTS

8,406,241 B2 3/2013 Ansari et al.
9,001,838 B2 4/2015 Ansari
(Continued)

OTHER PUBLICATIONS

Smith, "Belkin Prices Up Delayed Wireless HDMI Box", Register Hardware, Jul. 10, 2008, http://www.reghardware.co.uk/2008/07/10/belkin_prices_flywire.

Primary Examiner — Habte Mered
(74) *Attorney, Agent, or Firm* — Guntin & Gust, PLC; Joseph Hrutka

(57) **ABSTRACT**

A system that incorporates teachings of the present disclosure may include, for example, a centralized broadband gateway for a wireless communication system, including a router/gateway module which receives encoded compressed audio/video (A/V) streams and distributes the encoded compressed audio/video A/V streams; multiple audio/video decoders which receive the encoded compressed A/V streams from the a router/gateway module, decode the encoded compressed A/V streams, and output uncompressed A/V streams; and an integrated Wireless High Definition Multimedia Interface (WHDMI) which receives the uncompressed A/V streams from the multiple audio/video decoders and transmits the uncompressed A/V streams wirelessly to media devices, without deploying individual media processors at each media device. Other embodiments are disclosed.

20 Claims, 7 Drawing Sheets

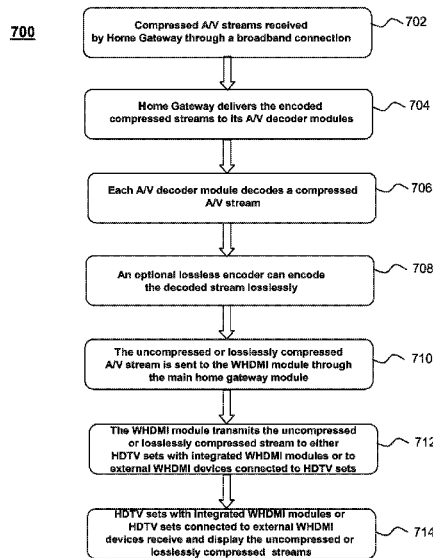

Related U.S. Application Data

continuation of application No. 13/771,189, filed on Feb. 20, 2013, now Pat. No. 9,001,838, which is a continuation of application No. 12/617,873, filed on Nov. 13, 2009, now Pat. No. 8,406,241.

(51) **Int. Cl.**

H04N 21/41 (2011.01)
H04N 21/4402 (2011.01)
H04N 19/90 (2014.01)
H04W 88/16 (2009.01)

(52) **U.S. Cl.**

CPC ... *H04N 21/4122* (2013.01); *H04N 21/43635* (2013.01); *H04N 21/440218* (2013.01); *H04W 88/16* (2013.01)

(56)

References Cited

U.S. PATENT DOCUMENTS

2006/0209890 A1 9/2006 MacMullan et al.
2008/0168312 A1 7/2008 Banks et al.
2011/0030025 A1 2/2011 Bertonis et al.
2011/0078721 A1 3/2011 Wang

100
FIG. 1

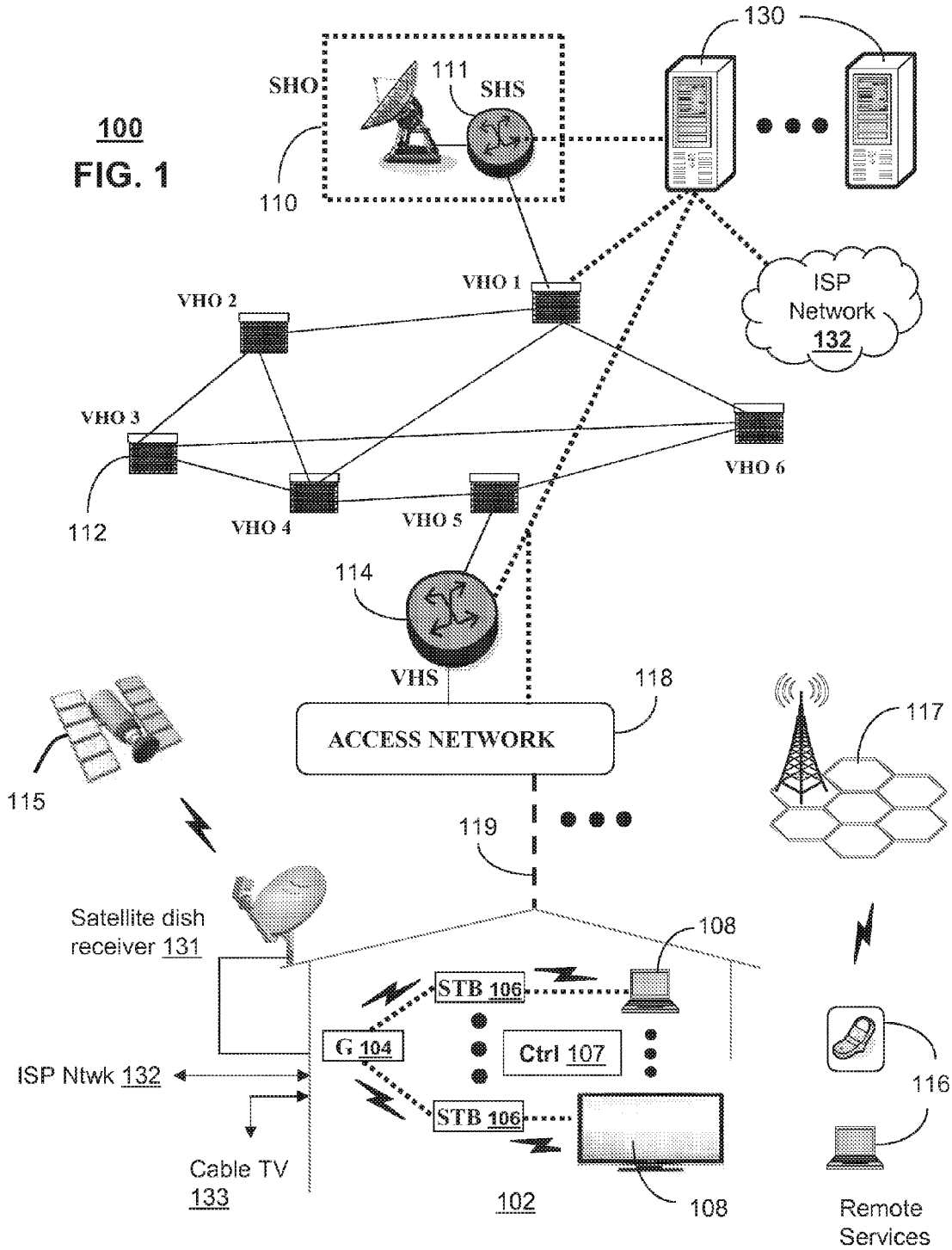

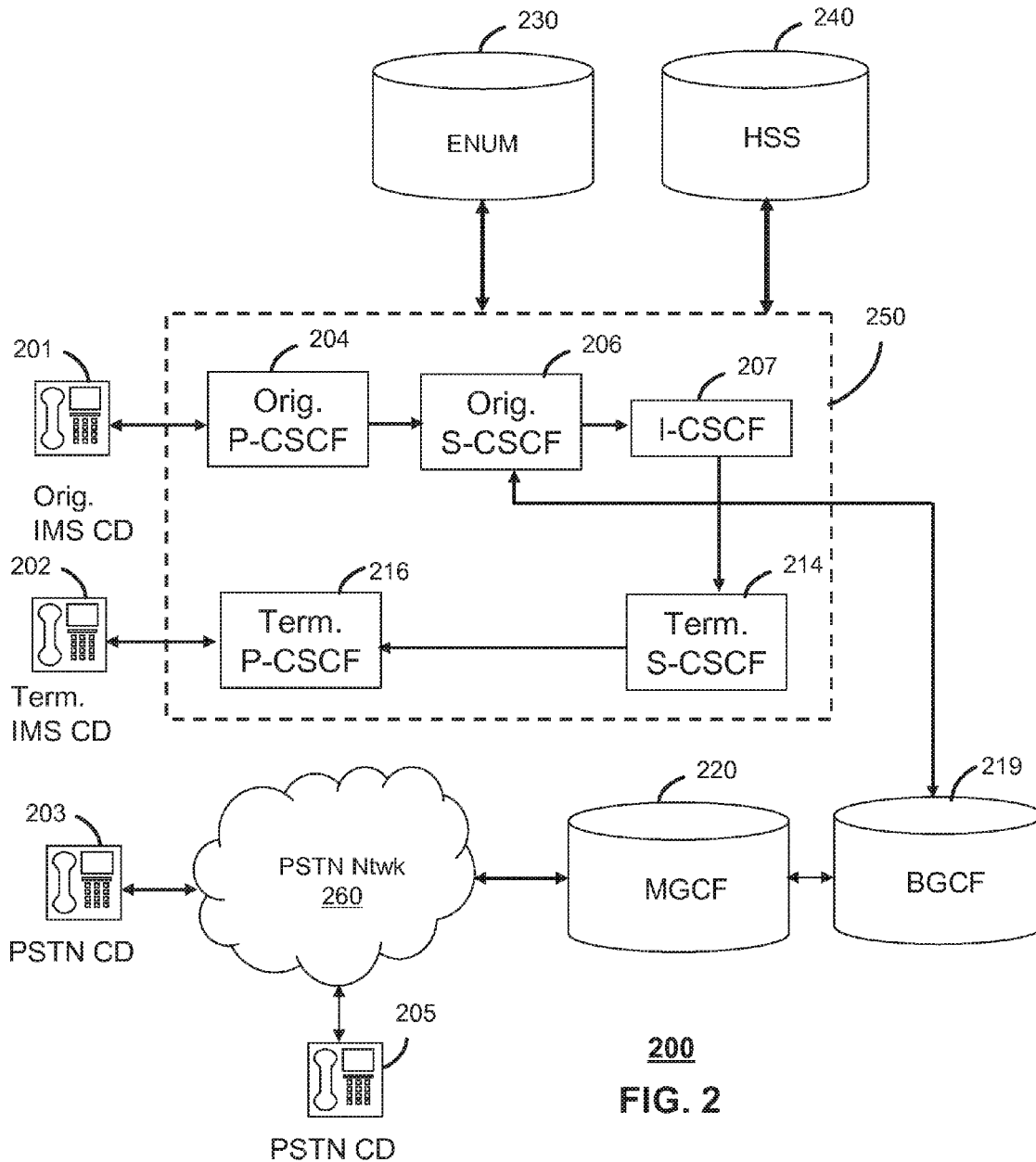

200
FIG. 2

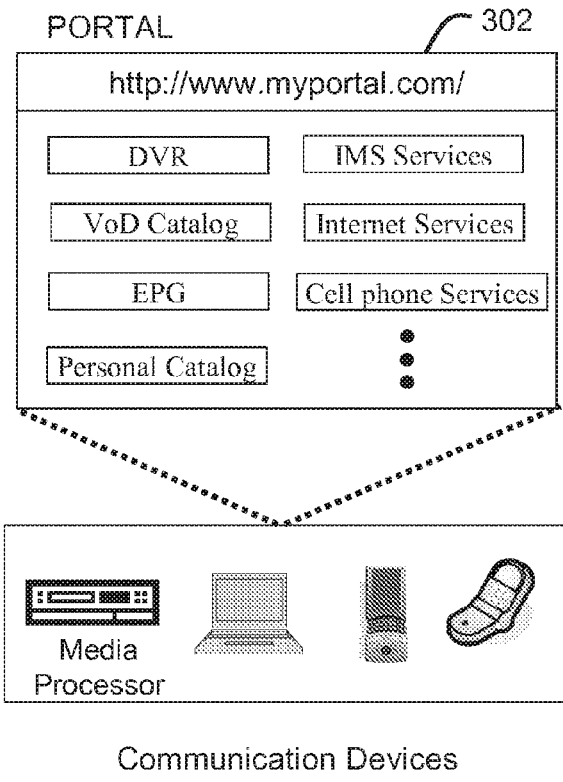

300
FIG. 3

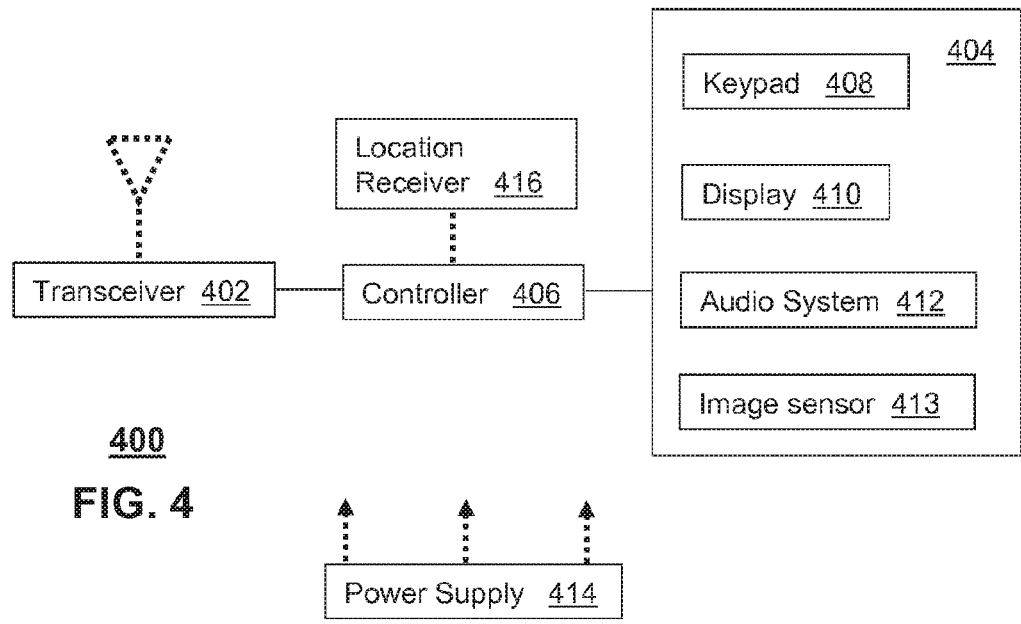

400
FIG. 4

FIG. 5
500

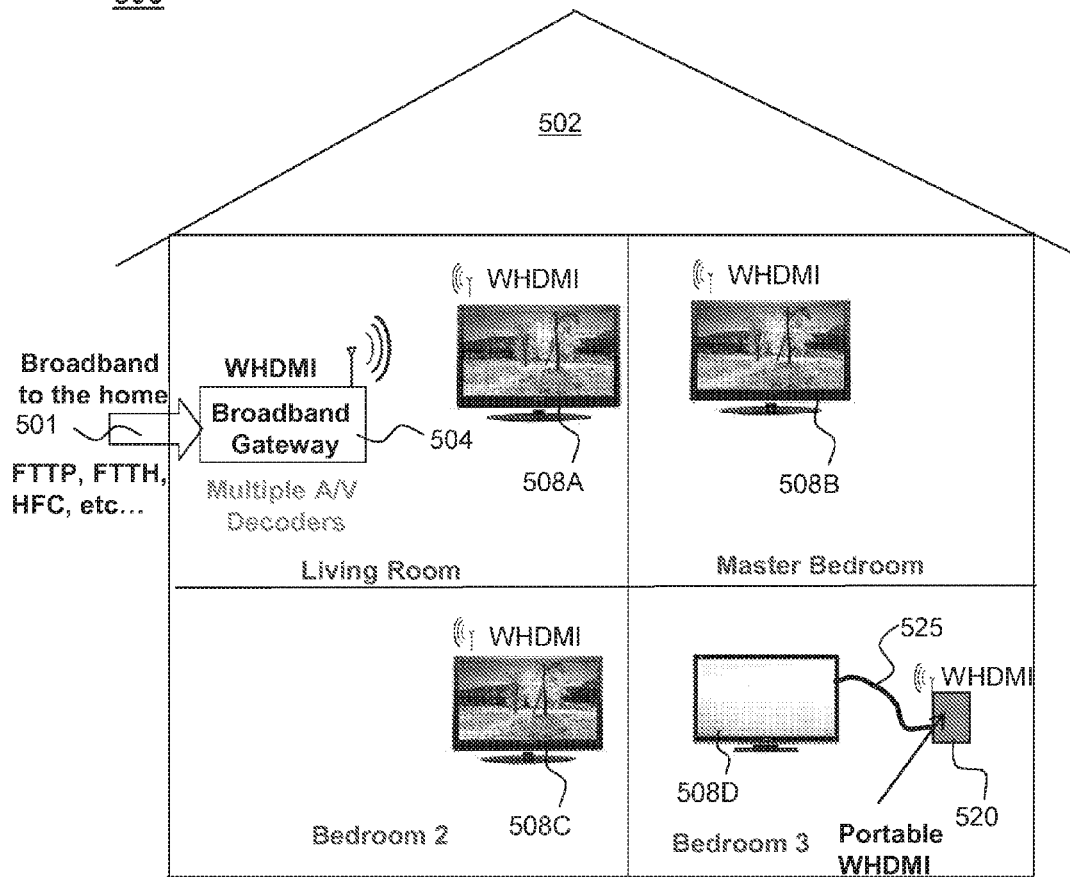

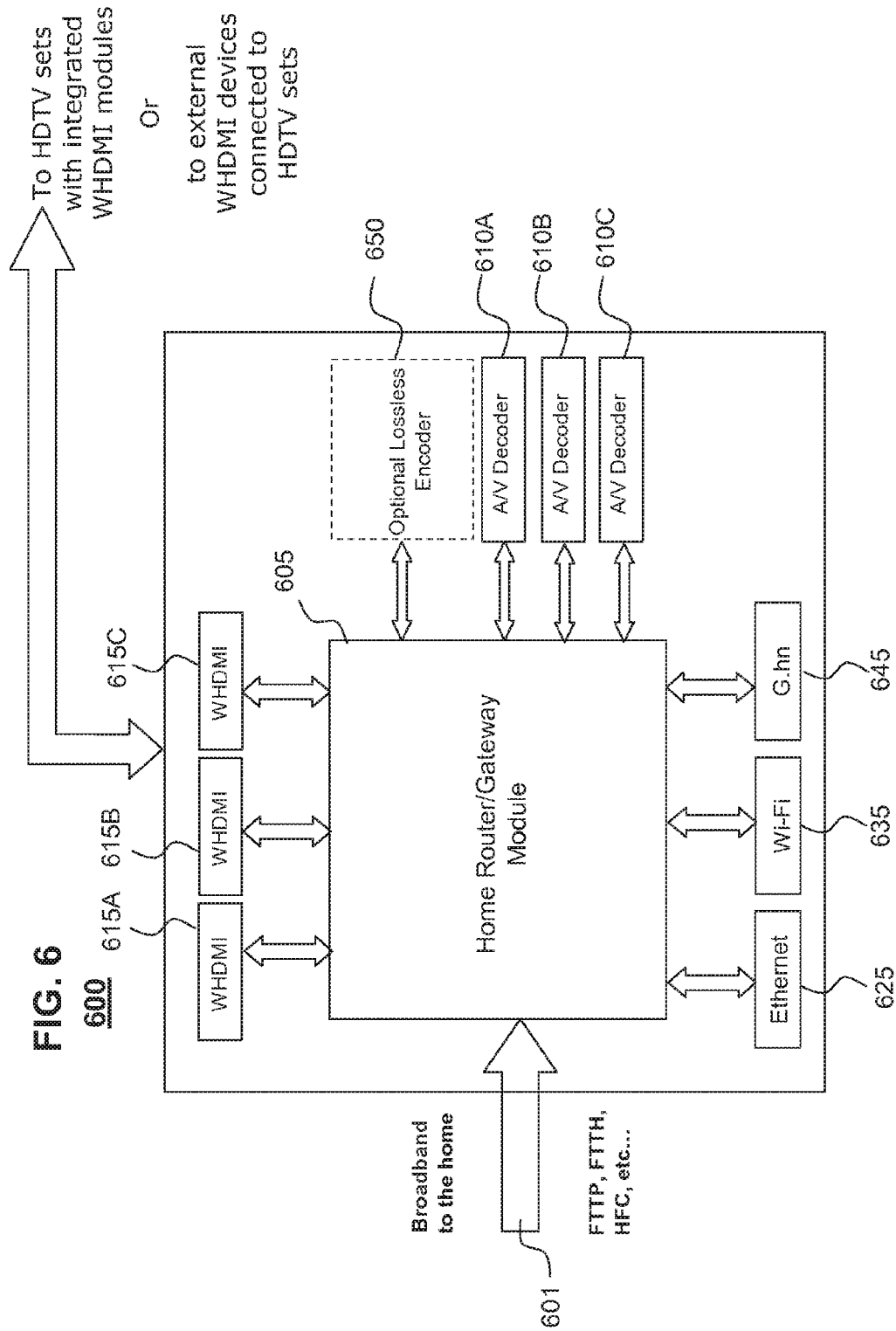
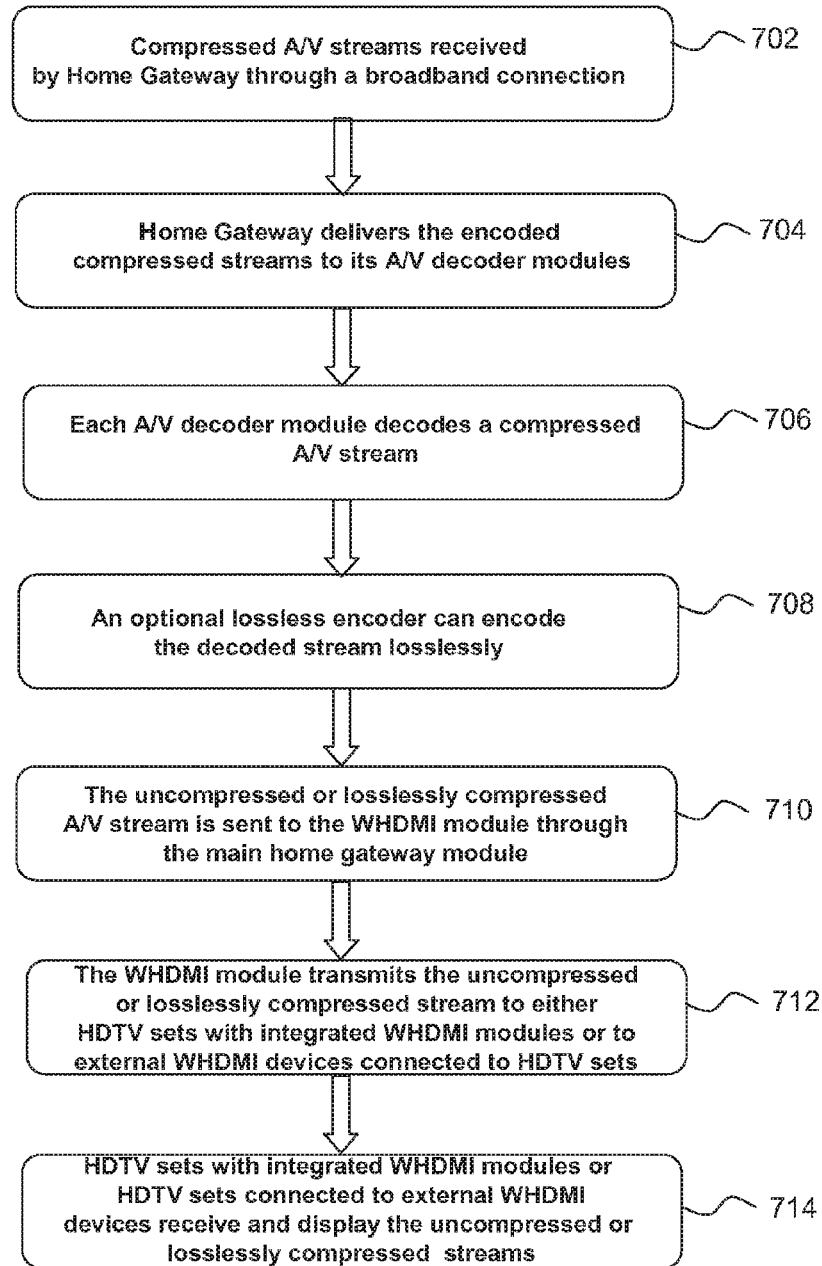
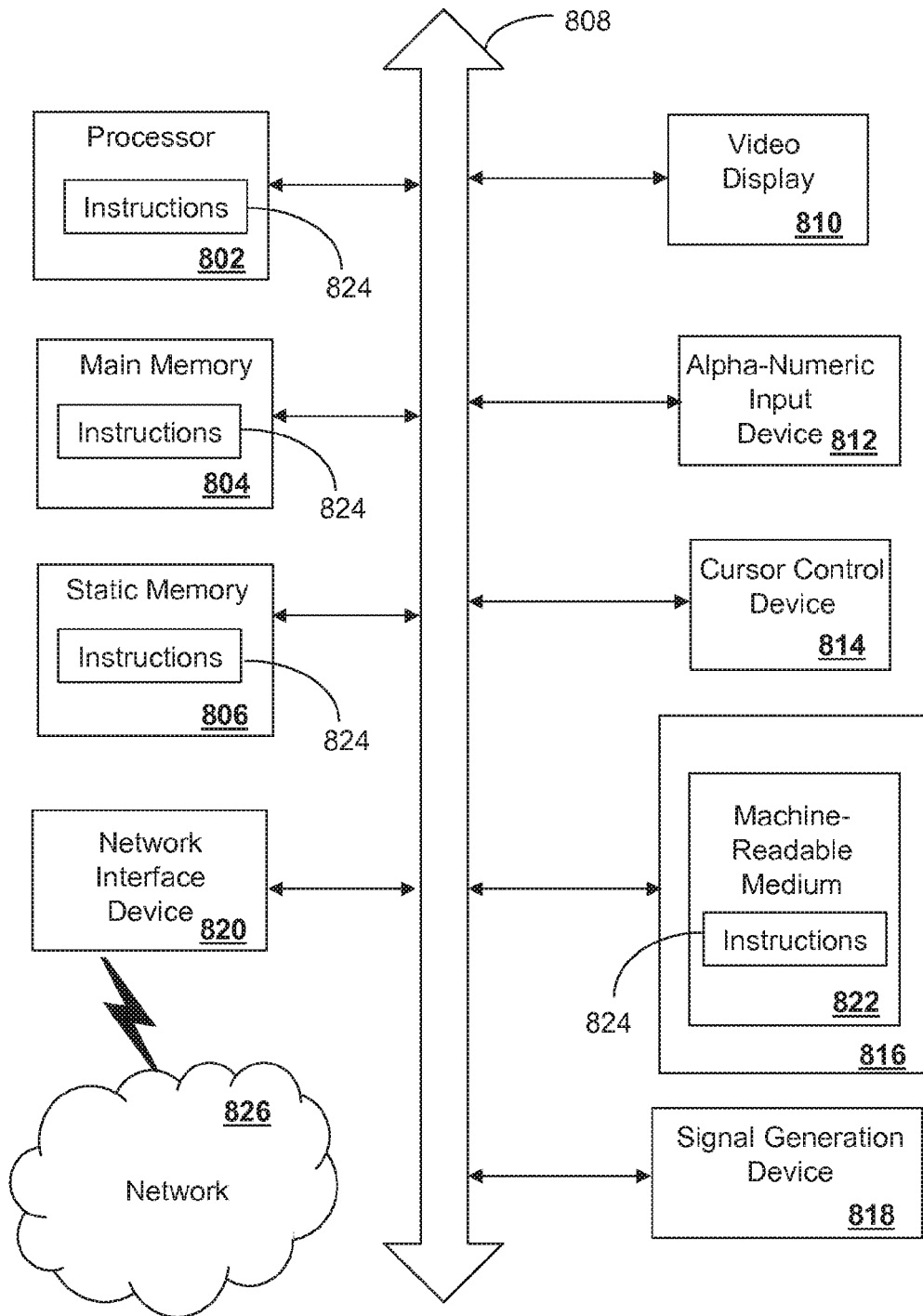

FIG. 7
700





800
FIG. 8

1

CENTRALIZED BROADBAND GATEWAY FOR A WIRELESS COMMUNICATION SYSTEM

CROSS-REFERENCE TO RELATED APPLICATIONS

This application is a Continuation of and claims priority to U.S. patent application Ser. No. 14/641,977, filed Mar. 9, 2015, now U.S. Patent Publication No. 2015/0181254, which is a Continuation of and claims priority to U.S. patent application Ser. No. 13/771,189, filed Feb. 20, 2013, now U.S. Pat. No. 9,001,838, which is a Continuation of and claims priority to U.S. patent application Ser. No. 12/617,873, filed Nov. 13, 2009, now U.S. Pat. No. 8,406,241. The contents of each of the foregoing are hereby incorporated by reference into this application as if set forth herein in full.

FIELD OF THE DISCLOSURE

The present disclosure relates generally to wireless communications and, more specifically, to a centralized broadband gateway for a wireless communication system.

BACKGROUND OF THE DISCLOSURE

Communication systems and electronic systems normally comprise a plurality of separate components that are coupled together by cabling. For example, cables are used for connecting television (TV) sets to cable set-top boxes (STBs), as well as for connecting various other devices utilized in a system. However, relying on cables can become cumbersome and unsightly when the number of cables increases to handle various components and peripheral devices. Also, popular wall mounted High Definition TV (HDTV) sets have the unsightly cable(s) hanging or extending from below the TV set and therefore are not aesthetically pleasing to the eye.

BRIEF DESCRIPTION OF THE DRAWINGS

FIGS. 1-2 depict illustrative embodiments of communication systems that provide media services;

FIG. 3 depicts an illustrative embodiment of a portal interacting with the communication systems of FIGS. 1-2;

FIG. 4 depicts an illustrative embodiment of a communication device utilized in the communication systems of FIGS. 1-2;

FIG. 5 depicts an illustrative embodiment of a centralized broadband gateway for a wireless communication system operating in portions of the communication systems of FIGS. 1 and 2;

FIG. 6 is a schematic view of an illustrative embodiment of a centralized broadband gateway operating in portions of the communication systems of FIGS. 1, 2 and 5;

FIG. 7 depicts an illustrative embodiment of a method operating in portions of the communication systems of FIGS. 1-2; and

FIG. 8 is a diagrammatic representation of a machine in the form of a computer system within which a set of instructions, when executed, may cause the machine to perform any one or more of the methodologies discussed herein.

DETAILED DESCRIPTION OF THE DRAWINGS

One embodiment of the present disclosure can entail a centralized broadband gateway for a wireless communica-

2

tion system, including: a router/gateway module which receives encoded compressed audio/video (A/V) streams and distributes the encoded compressed audio/video A/V streams; multiple audio/video decoders which receive the encoded compressed A/V streams from the a router/gateway module, decode the encoded compressed A/V streams, and output uncompressed A/V streams; and an integrated Wireless High Definition Multimedia Interface (WHDMI) which receives the uncompressed A/V streams from the multiple audio/video decoders and transmits the uncompressed A/V streams wirelessly to media devices, without deploying individual media processors at each media device.

Another embodiment of the present disclosure can entail a computer-readable storage medium, including computer instructions for instructing a communication system to: receive encoded compressed A/V streams from a broadband connection; distribute the encoded compressed A/V streams to multiple audio/video decoders which decode the encoded compressed A/V streams and which output uncompressed A/V streams; and transmit the uncompressed A/V streams wirelessly to multiple High Definition Television (HDTV) sets, without deploying individual media processors at each HDTV set.

Yet another embodiment of the present disclosure can entail a method of providing wireless communications from a centralized broadband gateway, including: receiving encoded compressed A/V streams from a broadband connection; distributing the encoded compressed audio/video A/V streams to multiple audio/video decoders which decode the encoded compressed A/V streams and which output uncompressed A/V streams; and transmitting the uncompressed A/V streams wirelessly to multiple HDTV sets, without deploying individual media processors at each HDTV set.

FIG. 1 depicts an illustrative embodiment of a first communication system **100** for delivering media content. The communication system **100** can represent an Internet Protocol Television (IPTV) broadcast media system. The IPTV media system can include a super head-end office (SHO) **110** with at least one super headend office server (SHS) **111** which receives media content from satellite and/or terrestrial communication systems. In the present context, media content can represent audio content, moving image content such as videos, still image content, or combinations thereof. The SHS server **111** can forward packets associated with the media content to video head-end servers (VHS) **114** via a network of video head-end offices (VHO) **112** according to a common multicast communication protocol.

The VHS **114** can distribute multimedia broadcast programs via an access network **118** to commercial and/or residential buildings **102** housing a gateway **104** (such as a common residential or commercial gateway). The access network **118** can represent a group of digital subscriber line access multiplexers (DSLAMs) located in a central office or a service area interface that provide broadband services over optical links or copper twisted pairs **119** to buildings **102**. The gateway **104** can use common communication technology to distribute broadcast signals to media processors **106** such as Set-Top Boxes (STBs) which in turn present broadcast channels to media devices **108** such as computers or television sets managed in some instances by a media controller **107** (such as an infrared or RF remote control).

The gateway **104**, the media processors **106**, and media devices **108** can utilize tethered interface technologies (such as coaxial or phone line wiring) or can operate over a common wireless access protocol. With these interfaces,

unicast communications can be invoked between the media processors **106** and subsystems of the IPTV media system for services such as video-on-demand (VoD), browsing an electronic programming guide (EPG), or other infrastructure services.

Some of the network elements of the IPTV media system can be coupled to one or more computing devices **130** a portion of which can operate as a web server for providing portal services over an Internet Service Provider (ISP) network **132** to wireline media devices **108** or wireless communication devices **116** by way of a wireless access base station **117** operating according to common wireless access protocols such as Wireless Fidelity (WiFi), or cellular communication technologies (such as GSM, CDMA, UMTS, WiMAX, Software Defined Radio or SDR, and so on).

It will be appreciated by an artisan of ordinary skill in the art that a satellite broadcast television system can be used in place of the IPTV media system. In this embodiment, signals transmitted by a satellite **115** supplying media content can be intercepted by a common satellite dish receiver **131** coupled to the building **102**. Modulated signals intercepted by the satellite dish receiver **131** can be submitted to the media processors **106** for generating broadcast channels which can be presented at the media devices **108**. The media processors **106** can be equipped with a broadband port to the ISP network **132** to enable infrastructure services such as VoD and EPG described above.

In yet another embodiment, an analog or digital broadcast distribution system such as cable TV system **133** can be used in place of the IPTV media system described above. In this embodiment the cable TV system **133** can provide Internet, telephony, and interactive media services.

It follows from the above illustrations that the present disclosure can apply to any present or future interactive over-the-air or landline media content services.

FIG. 2 depicts an illustrative embodiment of a communication system **200** employing an IP Multimedia Subsystem (IMS) network architecture to facilitate the combined services of circuit-switched and packet-switched systems. Communication system **200** can be overlaid or operably coupled with communication system **100** as another representative embodiment of communication system **100**.

Communication system **200** can comprise a Home Subscriber Server (HSS) **240**, a Telephone Number Mapping (ENUM) server **230**, and other common network elements of an IMS network **250**. The IMS network **250** can establish communications between IMS compliant communication devices (CD) **201**, **202**, Public Switched Telephone Network (PSTN) CDs **203**, **205**, and combinations thereof by way of a Media Gateway Control Function (MGCF) **220** coupled to a PSTN network **260**.

IMS CDs **201**, **202** can register with the IMS network **250** by contacting a Proxy Call Session Control Function (P-CSCF) which communicates with a corresponding Serving CSCF (S-CSCF) to register the CDs with at the HSS **240**. To initiate a communication session between CDs, an originating IMS CD **201** can submit a Session Initiation Protocol (SIP INVITE) message to an originating P-CSCF **204** which communicates with a corresponding originating S-CSCF **206**. The originating S-CSCF **206** can submit queries to the ENUM system **230** to translate an E.164 telephone number in the SIP INVITE to a SIP Uniform Resource Identifier (URI) if the terminating communication device is IMS compliant.

The SIP URI can be used by an Interrogating CSCF (I-CSCF) **207** to submit a query to the HSS **240** to identify

a terminating S-CSCF **214** associated with a terminating IMS CD such as reference **202**. Once identified, the I-CSCF **207** can submit the SIP INVITE to the terminating S-CSCF **214**. The terminating S-CSCF **214** can then identify a terminating P-CSCF **216** associated with the terminating CD **202**. The P-CSCF **216** then signals the CD **202** to establish communications.

If the terminating communication device is instead a PSTN CD such as references **203** or **205**, the ENUM system **230** can respond with an unsuccessful address resolution which can cause the originating S-CSCF **206** to forward the call to the MGCF **220** via a Breakout Gateway Control Function (BGCF) **219**. The MGCF **220** can then initiate the call to the terminating PSTN CD by common means over the PSTN network **260**.

The aforementioned communication process is symmetrical. Accordingly, the terms “originating” and “terminating” in FIG. 2 are interchangeable. It is further noted that communication system **200** can be adapted to support video conferencing by way of common protocols such as H.323. In addition, communication system **200** can be adapted to provide the IMS CDs **201**, **203** the multimedia and Internet services of communication system **100**.

FIG. 3 depicts an illustrative embodiment of a portal **302** which can operate from the computing devices **130** described earlier of communication **100** illustrated in FIG. 1. The portal **302** can be used for managing services of communication systems **100-200**. The portal **302** can be accessed by a Uniform Resource Locator (URL) with a common Internet browser such as Microsoft’s Internet Explorer™ using an Internet-capable communication device such as those described for FIGS. 1-2. The portal **302** can be configured, for example, to access a media processor **106** and services managed thereby such as a Digital Video Recorder (DVR), a VoD catalog, an EPG, a personal catalog (such as personal videos, pictures, audio recordings, etc.) stored in the media processor, provisioning IMS services described earlier, provisioning Internet services, provisioning cellular phone services, and so on.

FIG. 4 depicts an exemplary embodiment of a communication device **400**. Communication device **400** can serve in whole or in part as an illustrative embodiment of the communication devices of FIGS. 1-2. The communication device **400** can comprise a wireline and/or wireless transceiver **402** (herein transceiver **402**), a user interface (UI) **404**, a power supply **414**, a location receiver **416**, and a controller **406** for managing operations thereof. The transceiver **402** can support short-range or long-range wireless access technologies such as Bluetooth, WiFi, Digital Enhanced Cordless Telecommunications (DECT), or cellular communication technologies, just to mention a few. Cellular technologies can include, for example, CDMA-1X, UMTS/HSDPA, GSM/GPRS, TDMA/EDGE, EV/DO, WiMAX, SDR, and next generation cellular wireless communication technologies as they arise. The transceiver **402** can also be adapted to support circuit-switched wireline access technologies (such as PSTN), packet-switched wireline access technologies (such as TCP/IP, VoIP, etc.), and combinations thereof.

The UI **404** can include a depressible or touch-sensitive keypad **408** with a navigation mechanism such as a roller ball, joystick, mouse, or navigation disk for manipulating operations of the communication device **400**. The keypad **408** can be an integral part of a housing assembly of the communication device **400** or an independent device operably coupled thereto by a tethered wireline interface (such as a USB cable) or a wireless interface supporting for example

Bluetooth. The keypad **408** can represent a numeric dialing keypad commonly used by phones, and/or a Qwerty keypad with alphanumeric keys. The UI **404** can further include a display **410** such as monochrome or color LCD (Liquid Crystal Display), OLED (Organic Light Emitting Diode) or other suitable display technology for conveying images to an end user of the communication device **400**. In an embodiment where the display **410** is touch-sensitive, a portion or all of the keypad **408** can be presented by way of the display.

The UI **404** can also include an audio system **412** that utilizes common audio technology for conveying low volume audio (such as audio heard only in the proximity of a human ear) and high volume audio (such as speakerphone for hands free operation). The audio system **412** can further include a microphone for receiving audible signals of an end user. The audio system **412** can also be used for voice recognition applications. The UI **404** can further include an image sensor **413** such as a charged coupled device (CCD) camera for capturing still or moving images.

The power supply **414** can utilize common power management technologies such as replaceable and rechargeable batteries, supply regulation technologies, and charging system technologies for supplying energy to the components of the communication device **400** to facilitate long-range or short-range portable applications. The location receiver **416** can utilize common location technology such as a global positioning system (GPS) receiver for identifying a location of the communication device **400** based on signals generated by a constellation of GPS satellites, thereby facilitating common location services such as navigation.

The communication device **400** can use the transceiver **402** to also determine a proximity to a cellular, WiFi or Bluetooth access point by common power sensing techniques such as utilizing a received signal strength indicator (RSSI) and/or a signal time of arrival (TOA) or time of flight (TOF). The controller **406** can utilize computing technologies such as a microprocessor, a digital signal processor (DSP), and/or a video processor with associated storage memory such as a Flash, ROM, RAM, SRAM, DRAM or other storage technologies.

The communication device **400** can be adapted to perform the functions of the media processor **106**, the media devices **108**, or the portable communication devices **116** of FIG. 1, as well as the IMS CDs **201-202** and PSTN CDs **203-205** of FIG. 2. It will be appreciated that the communication device **400** can also represent other common devices that can operate in communication systems **100-200** of FIGS. 1-2 such as a gaming console and a media player.

FIG. 5 depicts an illustrative embodiment of a centralized broadband gateway **504** for a wireless communication system **500** operating in portions of the communication systems of FIGS. 1 and 2. More specifically, FIG. 5 shows a more detailed view of the commercial and/or residential buildings **102** shown in FIG. 1. Note that like references numerals denote like elements, except that a "5" precedes the numeral rather than a "1" (e.g., the commercial and/or residential building **102** is labeled as **502**). As will be discussed in more detail below, the centralized broadband gateway **504** comprises, for example, a multimedia home gateway with an integrated Wireless High Definition Multimedia Interface (WHDMI). The centralized broadband gateway **504** allows the transport of uncompressed high definition (HD) and standard definition (SD) video streams to, for example, one or more HDTV sets **508A**, **508B**, and **508C** that have an integrated Wireless High Definition Multimedia Interface (WHDMI) interface, or to an HDTV set **508D** without an integrated WHDMI and which thus includes an external

WHDMI device such as a portable WHDMI adapter **520** as a receiver. The external WHDMI adapter **520** may be connected to the HDTV **508D** by an HDMI cable **525**.

HDMI is a digital audio/video interface standard used for connecting audio/visual equipment such as HDTV sets to cable STBs, DBS satellite STBs, IPTV STBs and other devices such as home theater systems. With 19 wires wrapped in a single cable that resembles a USB wire, HDMI is able to carry a bandwidth of 5 gigabits per second (Gbps). HDMI is becoming the primary interface for connecting HDTV sets to HDMI compliant devices. The existing HDMI standard is designed for wired connections between devices. WHDMI enables the transmission of uncompressed high quality HDTV streams to be sent to devices that could support WHDMI. The present invention contemplates using, for example, Ultra-Wideband (UWB) and 802.11n extensions to transmit a significantly large amount of data to display devices with either built-in WHDMI interfaces or external WHDMI devices that are connected to television monitors. The UWB technology was designed initially to be used at very low energy levels for short-range high-bandwidth communications by using a large portion of the radio spectrum. However, UWB in WHDMI is capable of high data rate transmission of over 1 Gbps at distances of more than 60 feet through walls. Other wireless communications may be used such as, for example, a Wireless Local Area Network (WLAN) operating in accordance with existing standards or future standards or derivatives thereof.

Heretofore, existing systems have been unsuccessful at transmitting uncompressed Standard Definition (SD) or High Definition (HD) video over a home network. One reason for this is the lack of adequate bandwidth on a typical wired or wireless home network. In an embodiment consistent with the present invention, the centralized broadband gateway **504** may comprise multiple audio/video (A/V) decoders and can transmit uncompressed or losslessly compressed video over the WHDMI interface to multiple television sets in, for example, the home. By using a centralized home gateway architecture, television sets will no longer require dedicated digital decoder STBs. In an embodiment consistent with the present invention, HDTV sets with integrated WHDMI receive video through the integrated interface, and existing HDTV sets that do not have a WHDMI interface receive the uncompressed or losslessly compressed audio/video (A/V) stream through external WHDMI devices.

In FIG. 5, the high level block diagram shows the centralized broadband gateway **504** with multiple (for example, four) A/V decoders and an integrated WHDMI interface. As shown in FIG. 5, the centralized broadband gateway **504** may be used in any broadband access technology **501** (e.g., fiber-to-the-home (FTTH), fiber-to-the-premises (FTTP), and hybrid fiber-coaxial (HFC)). The centralized broadband gateway **504** receives multiple HD and SD compressed streams. Each compressed stream is decoded by the one of the multiple A/V decoders in the centralized broadband gateway **504** and the uncompressed or losslessly recompressed stream is transmitted to a corresponding television set **508A-C** with an integrated WHDMI interface (Living Room, Master Bedroom, Bedroom 2) or to the external WHDMI receiver **520** that is connected to the television set **508D** using the standard HDMI cable **525** (Bedroom 3). At each television location, only an RF remote control is needed to communicate with the centralized broadband gateway **504** for interacting (changing channel, browsing the GUIDE, etc. . . .). With the gateway architecture consistent with the present invention, there is no longer a need for

deploying individual STBs at the location of each of the television sets. High quality audio and video is received by WHDMI devices without the need to decode them, or, as discussed in more detail below, low-complexity, low-delay and very cost effective compression techniques can be used to transmit video wirelessly throughout the home. This approach eliminates expensive STBs that otherwise would be required. It will also enables the self-installation of IPTV services.

FIG. 6 is a schematic view of an illustrative embodiment of a centralized broadband gateway 600 (corresponding to centralized broadband gateway 504 shown in FIG. 5) operating in portions of the communication systems of FIGS. 1, 2 and 5. As noted above, encoded compressed A/V streams are delivered to the centralized broadband gateway 600 through a broadband connection 601 such as the FTTP, FTTH, HFC, or the like. The encoded compressed A/V streams are delivered to a home router/gateway module 605 of the centralized broadband gateway 600. The home router/gateway module 605 distributes the encoded compressed A/V streams to corresponding A/V decoder modules 610A, 610B, 610C. While three A/V decoder modules 610A-C are shown in FIG. 6, the centralized broadband gateway 600 is not limited to this configuration and can have more or less than three. For example, the centralized broadband gateway 504 shown in FIG. 5 has four A/V decoder modules, or one for each TV situated throughout the residential building 502. Moreover, the separate A/V decoder modules 610A-C can also be combined into a single unit that can distribute each of the streams to the respective wireless HDMI modules 615A, 615B, 615C. The A/V decoder modules 610A-C decode the encoded compressed A/V streams and send or output the uncompressed or losslessly compressed streams to the respective wireless HDMI modules 615A, 615B, 615C. The wireless HDMI modules 615A, 615B, 615C transmit the A/V streams wirelessly to either HDTV sets with integrated WHDMI modules (see, for example, TVs 508A-C in FIG. 5), or to external WHDMI devices connected to HDTV sets (see, for example, TV 508D using the portable WHDMI 520 in bedroom 3 as shown in FIG. 5). Each WHDMI module in the home router/gateway module 605 can be configured to transmit its corresponding A/V stream to a specific end device (e.g., HDTV set or external WHDMI devices). Moreover, like the A/V decoders, the wireless HDMI modules 615A, 615B, 615C can be combined into a single unit which transmits the corresponding A/V streams to each of the specific end devices (e.g., HDTV set or external WHDMI devices).

The home router/gateway module 605 can have other network interfaces such as Ethernet 625, Wi-Fi 635, G.hn ("next generation" home network) 645, for example, used for data networking within the home.

In order to make use of the WHDMI bandwidth more efficiently, an embodiment of the present invention may make use of low complexity and low delay lossless video compression schemes that allow the transport of multiple HD streams to devices with WHDMI interfaces in, for example, the home. In this way, optimal use is made of the bandwidth over the wireless link. There are a number of very low-complexity and low-delay video compression algorithms such as Bit Plane Encoding or lossless Predictive Coding that may be used to compress video without any loss. The low-delay, low-complexity lossless video compression techniques are also cost effective. Thus, an optional lossless encoder 650 can be included which encodes the decoded A/V streams losslessly resulting in losslessly compressed A/V streams.

FIG. 7 depicts an illustrative method 700 that operates in portions of the communication system/wireless communication system of FIGS. 1, 2 and 5. Method 700 can begin with step 702 in which compressed A/V streams are received by the centralized broadband gateway (504, 600) through a broadband connection (501, 601). In step 704, the home router/gateway module 605 delivers the encoded compressed streams to the various A/V decoder modules 610A-C. In step 706, each A/V decoder module 610A-C decodes an encoded compressed A/V stream. An optional lossless encoder 650 can encode the decoded stream losslessly, as at step 708. At step 710, the uncompressed or losslessly compressed A/V stream is sent to the corresponding WHDMI modules 615A-C through the main home router/gateway module 605. At step 712, each of the WHDMI modules 615A-C transmits its uncompressed or losslessly compressed stream to either HDTV sets with integrated WHDMI modules or to external WHDMI devices connected to HDTV sets. At step 714, the HDTV sets with integrated WHDMI modules, or the HDTV sets connected to corresponding external WHDMI devices, receive and display the uncompressed or losslessly compressed streams.

Based on the foregoing, some of the benefits of the centralized broadband gateway consistent with the present invention include: 1) wireless transmission of high quality either uncompressed or losslessly encoded HD/SD video with a low complexity, low delay and low cost encoder; 2) no HDMI wire/cable is required; 3) enables existing HDTV sets with wired HDMI interface to receive HDMI video wirelessly; 4) no need to deploy individual STBs at each television location; 5) enables self-installation of IPTV services; and 6) enables the transmission of an HDTV signal to HDTV sets from a centralized gateway without requiring to deploy dedicated STBs at each television location.

Upon reviewing the aforementioned embodiments, it would be evident to an artisan with ordinary skill in the art that said embodiments can be modified, reduced, or enhanced without departing from the scope and spirit of the claims described below. For example, the centralized broadband gateway consistent with the present invention can be deployed by various cable, direct broadcast satellite (DBS), IPTV, and other entertainment service providers.

Other suitable modifications can be applied to the present disclosure without departing from the scope of the claims below. Accordingly, the reader is directed to the claims section for a fuller understanding of the breadth and scope of the present disclosure.

FIG. 8 depicts an exemplary diagrammatic representation of a machine in the form of a computer system 800 within which a set of instructions, when executed, may cause the machine to perform any one or more of the methodologies discussed above. In some embodiments, the machine operates as a standalone device. In some embodiments, the machine may be connected (e.g., using a network) to other machines. In a networked deployment, the machine may operate in the capacity of a server or a client user machine in server-client user network environment, or as a peer machine in a peer-to-peer (or distributed) network environment.

The machine may comprise a server computer, a client user computer, a personal computer (PC), a tablet PC, a laptop computer, a desktop computer, a control system, a network router, switch or bridge, or any machine capable of executing a set of instructions (sequential or otherwise) that specify actions to be taken by that machine. It will be understood that a device of the present disclosure includes broadly any electronic device that provides voice, video or

data communication. Further, while a single machine is illustrated, the term “machine” shall also be taken to include any collection of machines that individually or jointly execute a set (or multiple sets) of instructions to perform any one or more of the methodologies discussed herein.

The computer system **800** may include a processor **802** (e.g., a central processing unit (CPU), a graphics processing unit (GPU, or both), a main memory **804** and a static memory **806**, which communicate with each other via a bus **808**. The computer system **800** may further include a video display unit **810** (e.g., a liquid crystal display (LCD), a flat panel, a solid state display, or a cathode ray tube (CRT)). The computer system **800** may include an input device **812** (e.g., a keyboard), a cursor control device **814** (e.g., a mouse), a disk drive unit **816**, a signal generation device **818** (e.g., a speaker or remote control) and a network interface device **820**.

The disk drive unit **816** may include a machine-readable medium **822** on which is stored one or more sets of instructions (e.g., software **824**) embodying any one or more of the methodologies or functions described herein, including those methods illustrated above. The instructions **824** may also reside, completely or at least partially, within the main memory **804**, the static memory **806**, and/or within the processor **802** during execution thereof by the computer system **800**. The main memory **804** and the processor **802** also may constitute machine-readable media.

Dedicated hardware implementations including, but not limited to, application specific integrated circuits, programmable logic arrays and other hardware devices can likewise be constructed to implement the methods described herein. Applications that may include the apparatus and systems of various embodiments broadly include a variety of electronic and computer systems. Some embodiments implement functions in two or more specific interconnected hardware modules or devices with related control and data signals communicated between and through the modules, or as portions of an application-specific integrated circuit. Thus, the example system is applicable to software, firmware, and hardware implementations.

In accordance with various embodiments of the present disclosure, the methods described herein are intended for operation as software programs running on a computer processor. Furthermore, software implementations can include, but not limited to, distributed processing or component/object distributed processing, parallel processing, or virtual machine processing can also be constructed to implement the methods described herein.

The present disclosure contemplates a machine readable medium containing instructions **824**, or that which receives and executes instructions **824** from a propagated signal so that a device connected to a network environment **826** can send or receive voice, video or data, and to communicate over the network **826** using the instructions **824**. The instructions **824** may further be transmitted or received over a network **826** via the network interface device **820**.

While the machine-readable medium **822** is shown in an example embodiment to be a single medium, the term “machine-readable medium” should be taken to include a single medium or multiple media (e.g., a centralized or distributed database, and/or associated caches and servers) that store the one or more sets of instructions. The term “machine-readable medium” shall also be taken to include any medium that is capable of storing, encoding or carrying a set of instructions for execution by the machine and that cause the machine to perform any one or more of the methodologies of the present disclosure.

The term “machine-readable medium” shall accordingly be taken to include, but not be limited to: solid-state memories such as a memory card or other package that houses one or more read-only (non-volatile) memories, random access memories, or other re-writable (volatile) memories; magneto-optical or optical medium such as a disk or tape; and/or a digital file attachment to e-mail or other self-contained information archive or set of archives is considered a distribution medium equivalent to a tangible storage medium. Accordingly, the disclosure is considered to include any one or more of a machine-readable medium or a distribution medium, as listed herein and including art-recognized equivalents and successor media, in which the software implementations herein are stored.

Although the present specification describes components and functions implemented in the embodiments with reference to particular standards and protocols, the disclosure is not limited to such standards and protocols. Each of the standards for Internet and other packet switched network transmission (e.g., TCP/IP, UDP/IP, HTML, and HTTP) represent examples of the state of the art. Such standards are periodically superseded by faster or more efficient equivalents having essentially the same functions. Accordingly, replacement standards and protocols having the same functions are considered equivalents.

The illustrations of embodiments described herein are intended to provide a general understanding of the structure of various embodiments, and they are not intended to serve as a complete description of all the elements and features of apparatus and systems that might make use of the structures described herein. Many other embodiments will be apparent to those of skill in the art upon reviewing the above description. Other embodiments may be utilized and derived therefrom, such that structural and logical substitutions and changes may be made without departing from the scope of this disclosure. Figures are also merely representational and may not be drawn to scale. Certain proportions thereof may be exaggerated, while others may be minimized. Accordingly, the specification and drawings are to be regarded in an illustrative rather than a restrictive sense.

Such embodiments of the inventive subject matter may be referred to herein, individually and/or collectively, by the term “invention” merely for convenience and without intending to voluntarily limit the scope of this application to any single invention or inventive concept if more than one is in fact disclosed. Thus, although specific embodiments have been illustrated and described herein, it should be appreciated that any arrangement calculated to achieve the same purpose may be substituted for the specific embodiments shown. This disclosure is intended to cover any and all adaptations or variations of various embodiments. Combinations of the above embodiments, and other embodiments not specifically described herein, will be apparent to those of skill in the art upon reviewing the above description.

What is claimed is:

1. A gateway, comprising:

- a processing system including a processor; and
- a memory that stores executable instructions that, when executed by the processing system, facilitate performance of operations, comprising:
 - receiving encoded compressed audio/video streams;
 - decoding the encoded compressed audio/video streams to generate uncompressed audio/video streams; and
 - providing the uncompressed audio/video streams to a plurality of media devices, wherein each media device of the plurality of media devices comprises a

11

wireless high definition multimedia interface to receive an uncompressed audio/video stream of the uncompressed audio/video streams, and wherein a respective uncompressed audio/video stream is displayed without accessing a media processor at a respective media device of the plurality of media devices.

2. The gateway of claim 1, further comprising: a wireless fidelity network interface that transmits data for data networking; and
- a plurality of audio/video decoders that provide the uncompressed audio/video streams to each media device of the plurality of media devices.
3. The gateway of claim 2, wherein the plurality of audio/video decoders each comprise a bit plane encoding encoder.
4. The gateway of claim 1, further comprising: an Ethernet network interface that transmits data for data networking; and an audio/video decoder that provides the uncompressed audio/video streams to the respective media device based on the encoded compressed audio/video streams.
5. The gateway of claim 4, wherein the audio/video decoder comprises a lossless predictive coding encoder.
6. The gateway of claim 5, wherein the lossless predictive coding encoder comprises a bit plane encoding encoder.
7. The gateway of claim 1, wherein the encoded compressed audio/video streams is received over a hybrid fiber-coaxial connection.
8. The gateway of claim 1, wherein the encoded compressed audio/video streams is received over a broadband connection.
9. The gateway of claim 1, wherein the encoded compressed audio/video streams includes high-definition content and standard-definition content.
10. The gateway of claim 1, wherein the encoded compressed audio/video streams are received from an interactive television network.
11. A non-transitory, machine-readable storage medium, comprising executable instructions that, when executed by a processing system including a processor of a gateway, facilitate performance of operations, comprising:
 - receiving, at the gateway, encoded compressed audio/video streams from a broadband connection;
 - distributing, by the gateway, the encoded compressed audio/video streams to multiple audio/video decoders of the gateway, wherein the multiple audio/video decoders generate a first set of uncompressed audio/video streams and a second set of uncompressed audio/video streams;
 - wirelessly transmitting, by a plurality of wireless high definition multimedia interfaces of the gateway, the first set of the uncompressed audio/video streams to a first media device; and
 - wirelessly transmitting, by the plurality of wireless high definition multimedia interfaces of the gateway, the second set of the uncompressed audio/video streams to a second media device.
12. The non-transitory, machine-readable storage medium of claim 11, wherein the multiple audio/video decoders and the plurality of wireless high definition multimedia interfaces of the gateway have a one-to-one correspondence.
13. The non-transitory, machine-readable storage medium of claim 11, wherein the first media device comprises a first wireless high definition multimedia interface to receive the

12

first set of the uncompressed audio/video streams, and wherein the first set of the uncompressed audio/video streams is displayed without accessing a media processor at the first media device.

14. The non-transitory, machine-readable storage medium of claim 11, wherein the second media device comprises a second wireless high definition multimedia interface to receive the second set of the uncompressed audio/video streams, and wherein the second set of the uncompressed audio/video streams is displayed without accessing a media processor at the second media device.

15. The non-transitory, machine-readable storage medium of claim 11, wherein the encoded compressed audio/video streams includes high-definition content and standard-definition content.

16. The non-transitory, machine-readable storage medium of claim 11, wherein the multiple audio/video decoders further generate a set of losslessly compressed audio/video streams,

wherein the gateway wirelessly transmits the set of losslessly compressed audio/video streams to a third media device, and

wherein the third media device comprises a third wireless high definition multimedia interface to receive the set of losslessly compressed audio/video streams, and wherein the set of losslessly compressed audio/video streams is displayed without accessing a media processor at the third media device.

17. A method, comprising: receiving, by a gateway through a broadband connection, audio/video streams;

distributing, by the gateway, the audio/video streams to multiple audio/video decoders of the gateway;

generating, by the multiple audio/video decoders of the gateway, uncompressed audio/video streams, wherein the uncompressed audio/video streams include a first set of signals and a second set of signals, wherein the first set of signals comprise an uncompressed video signal, and wherein the second set of signals comprise a losslessly compressed video signal; and

wirelessly transmitting, by a first wireless high definition multimedia interface of the gateway, the first set of signals to a first set of high definition television sets, wherein the first set of high definition television sets receive the first set of signals via a first wireless high definition multimedia interface; and

wirelessly transmitting, by a second wireless high definition multimedia interface of the gateway, the second set of signals to a second set of high definition television sets, wherein the second set of high definition television sets receive the second set of signals via a second wireless high definition multimedia interface.

18. The method of claim 17, wherein the first set of high definition television sets receive the first set of signals directly through the first wireless high definition multimedia interface without additional processing of the first set of signals to display content of the first set of signals.

19. The method of claim 17, wherein the multiple audio/video decoders comprise a lossless encoder and an uncompressed encoder.

20. The method of claim 19, wherein the lossless encoder uses low complexity and low delay lossless video compression protocols.