



US009938873B2

(12) **United States Patent**  
**Bartlett**

(10) **Patent No.:** **US 9,938,873 B2**  
(45) **Date of Patent:** **Apr. 10, 2018**

(54) **MUFFLER FOR AUTOMOBILE**  
(71) Applicant: **Black Widow Performance, Inc.**,  
Santa Ana, CA (US)  
(72) Inventor: **William Lee Bartlett**, San Bernardino,  
CA (US)  
(73) Assignee: **Black Widow Performance, Inc.**,  
Santa Ana, CA (US)

(58) **Field of Classification Search**  
CPC ..... F01N 1/083; F01N 1/026; F01N 1/006;  
F01N 1/088; F01N 13/1872; F01N  
13/1838; F01N 2470/02; F01N 2470/30;  
F01N 2470/04  
USPC ..... 181/281, 268, 269, 270, 272, 275  
See application file for complete search history.

(\* ) Notice: Subject to any disclaimer, the term of this  
patent is extended or adjusted under 35  
U.S.C. 154(b) by 0 days.

(21) Appl. No.: **15/280,698**

(22) Filed: **Sep. 29, 2016**

(65) **Prior Publication Data**  
US 2017/0044943 A1 Feb. 16, 2017

**Related U.S. Application Data**  
(63) Continuation of application No. 13/761,038, filed on  
Feb. 6, 2013, now Pat. No. 9,488,079.  
(60) Provisional application No. 61/596,088, filed on Feb.  
7, 2012.

(51) **Int. Cl.**  
**F01N 1/02** (2006.01)  
**F01N 13/08** (2010.01)  
**F01N 1/08** (2006.01)  
**F01N 13/18** (2010.01)  
**G10K 11/16** (2006.01)  
**F01N 1/00** (2006.01)  
**F01N 13/00** (2010.01)  
(52) **U.S. Cl.**  
CPC ..... **F01N 1/083** (2013.01); **F01N 1/026**  
(2013.01); **F01N 13/1872** (2013.01); **G10K**  
**11/161** (2013.01); **F01N 2470/02** (2013.01);  
**F01N 2470/30** (2013.01)

(56) **References Cited**  
**U.S. PATENT DOCUMENTS**  
199,512 A \* 1/1878 Buzzell ..... F01N 1/08  
181/239  
2,122,086 A 6/1938 Chase  
2,512,155 A 6/1950 Hill  
2,727,584 A \* 12/1955 Marx ..... F01N 1/083  
181/270  
2,896,743 A \* 7/1959 Bradshaw ..... B01D 45/08  
181/270

(Continued)  
**FOREIGN PATENT DOCUMENTS**  
JP 57102507 A 6/1982

*Primary Examiner* — Edgardo San Martin  
(74) *Attorney, Agent, or Firm* — Stetina Brunda Garred &  
Brucker

(57) **ABSTRACT**  
A muffler for an exhaust system of a gas combustion engine,  
which comprises a muffler body (14) connected to an  
exhaust pipe inlet (10a), an exhaust pipe outlet (11a) to the  
tailpipe connected to the muffler body (14), and adjacent  
baffles (23, 24) within the muffler body (14), characterized  
in that the exhaust pipe inlet (10a), the exhaust pipe outlet  
(11a) and the adjacent baffles (23, 24) are in line without  
significant restriction to gas exhaust flow and having baffle  
openings (21, 22) and baffle louver openings (18b, 19b) to  
the central muffler chamber (17), whereby the central muf-  
fler chamber route (17) is generally a straight line from the  
exhaust inlet pipe (10a) to the exhaust pipe outlet (11a).

**20 Claims, 5 Drawing Sheets**

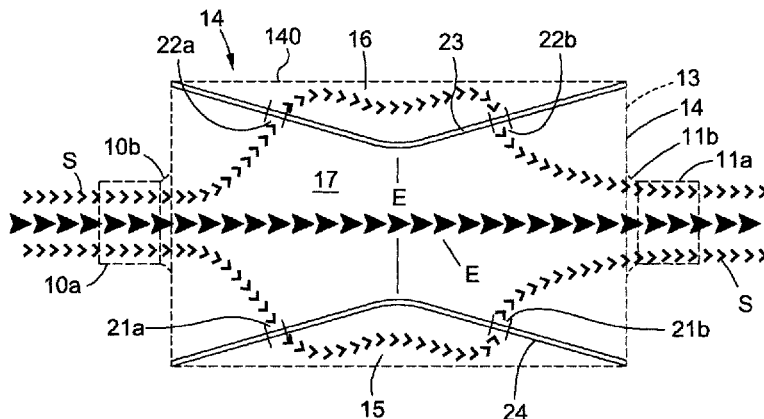

(56)

**References Cited**

U.S. PATENT DOCUMENTS

3,092,206	A *	6/1963	Moreau	.....	F01N 1/083	181/270	5,739,484	A	4/1998	Jones	
3,095,944	A *	7/1963	Buxton	.....	F01N 13/005	181/246	5,773,770	A	6/1998	Jones	
3,811,531	A *	5/1974	Forssman	.....	F01N 1/082	181/258	5,824,972	A *	10/1998	Butler	..... F01N 1/087
3,987,868	A	10/1976	Betts				5,892,186	A	4/1999	Flugger	181/265
4,287,962	A *	9/1981	Ingard	.....	F01N 1/003	181/224	5,949,035	A *	9/1999	Herold	..... F01N 1/08
4,371,053	A *	2/1983	Jones	.....	F01N 1/02	181/249	6,364,054	B1	4/2002	Bubulka et al.	181/282
4,790,409	A *	12/1988	Deaver	.....	F01N 1/084	181/265	6,609,590	B2 *	8/2003	Zelinski	..... F01N 1/083
4,890,691	A *	1/1990	Ching-ho	.....	F01N 1/083	181/264	7,549,512	B2	6/2009	Newberry	181/264
4,920,746	A *	5/1990	Gebelius	.....	F01N 1/083	181/231	7,793,758	B2 *	9/2010	Rimback	..... F01N 1/02
5,304,749	A *	4/1994	Crandell	.....	F01N 1/083	181/264	8,083,026	B1 *	12/2011	Butler	..... F01N 1/083
							8,640,822	B2 *	2/2014	Schooler	..... F01N 13/00
							8,746,401	B2 *	6/2014	Butler	..... F01N 1/085
							9,488,079	B2 *	11/2016	Bartlett	..... F01N 13/1872
							2011/0088968	A1	4/2011	Kempf et al.	

\* cited by examiner

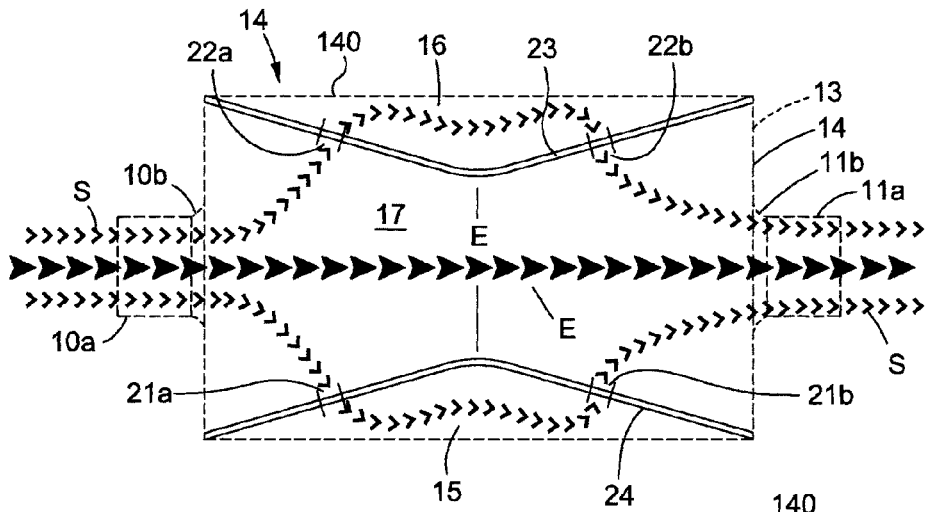

FIG. 1A

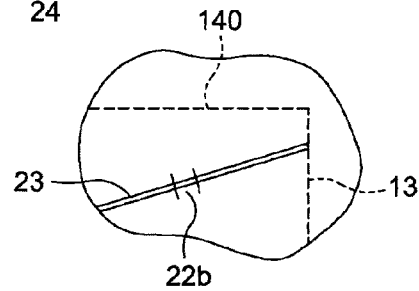

FIG. 1B

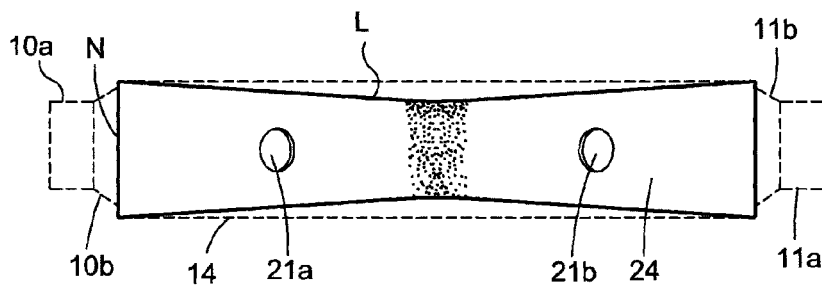

FIG. 1C

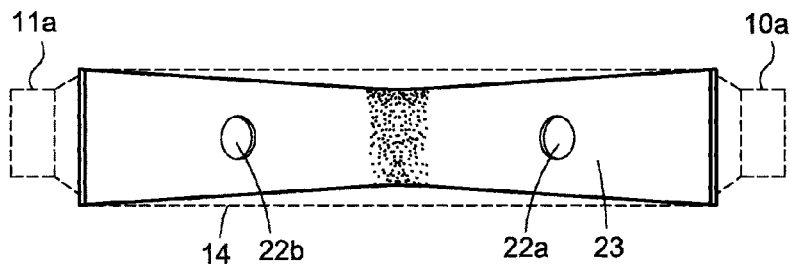

FIG. 1D

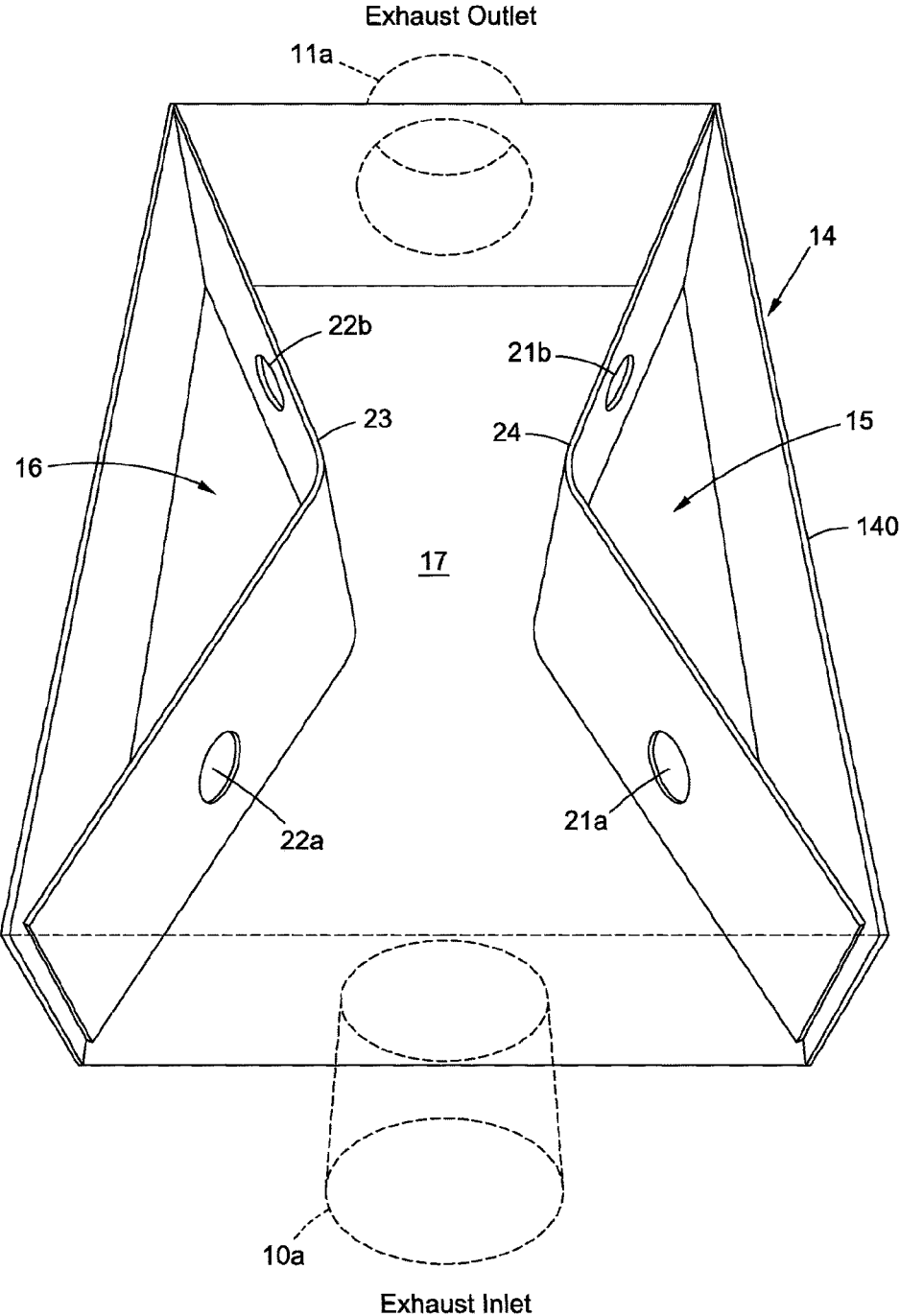

FIG. 2

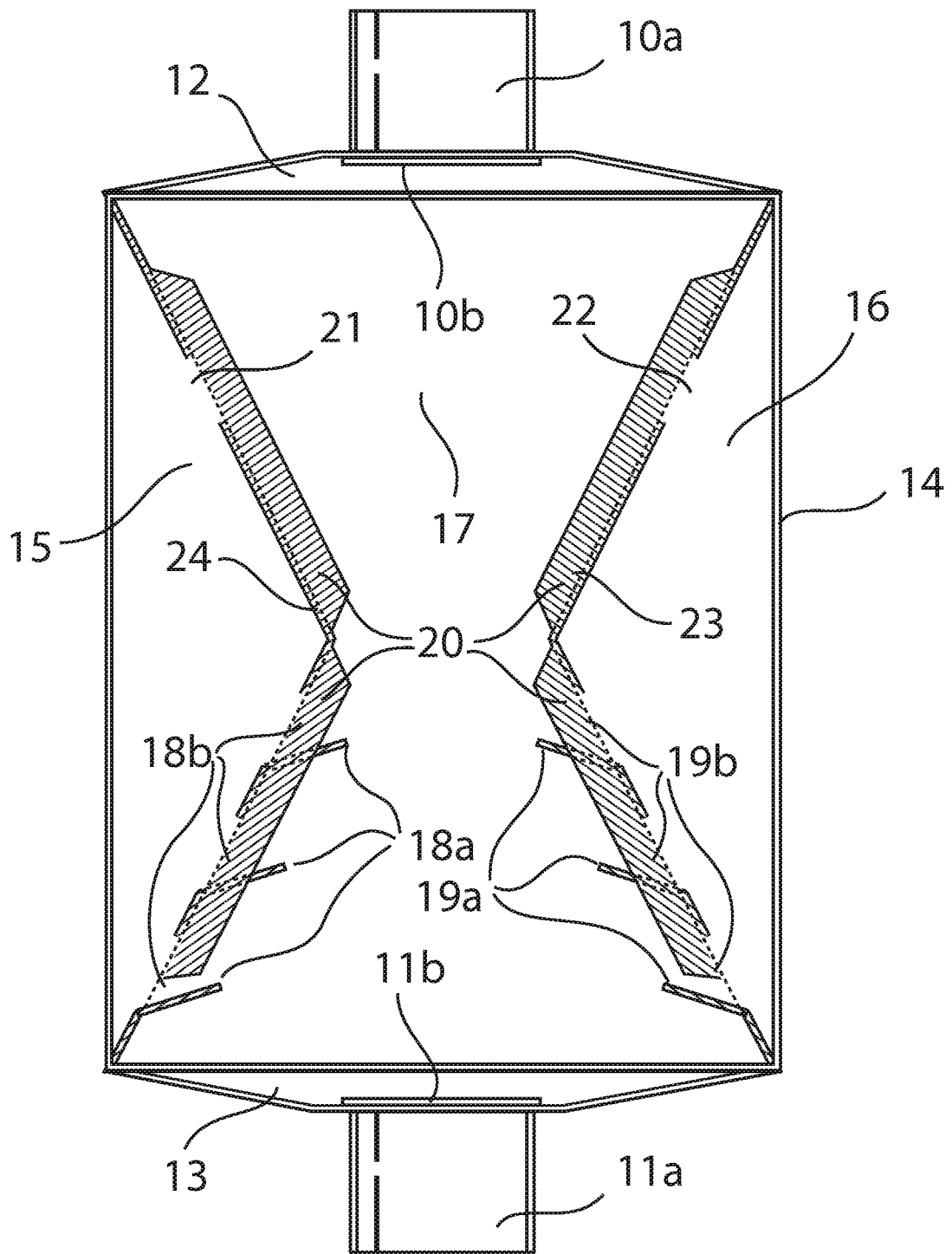

FIG. 3

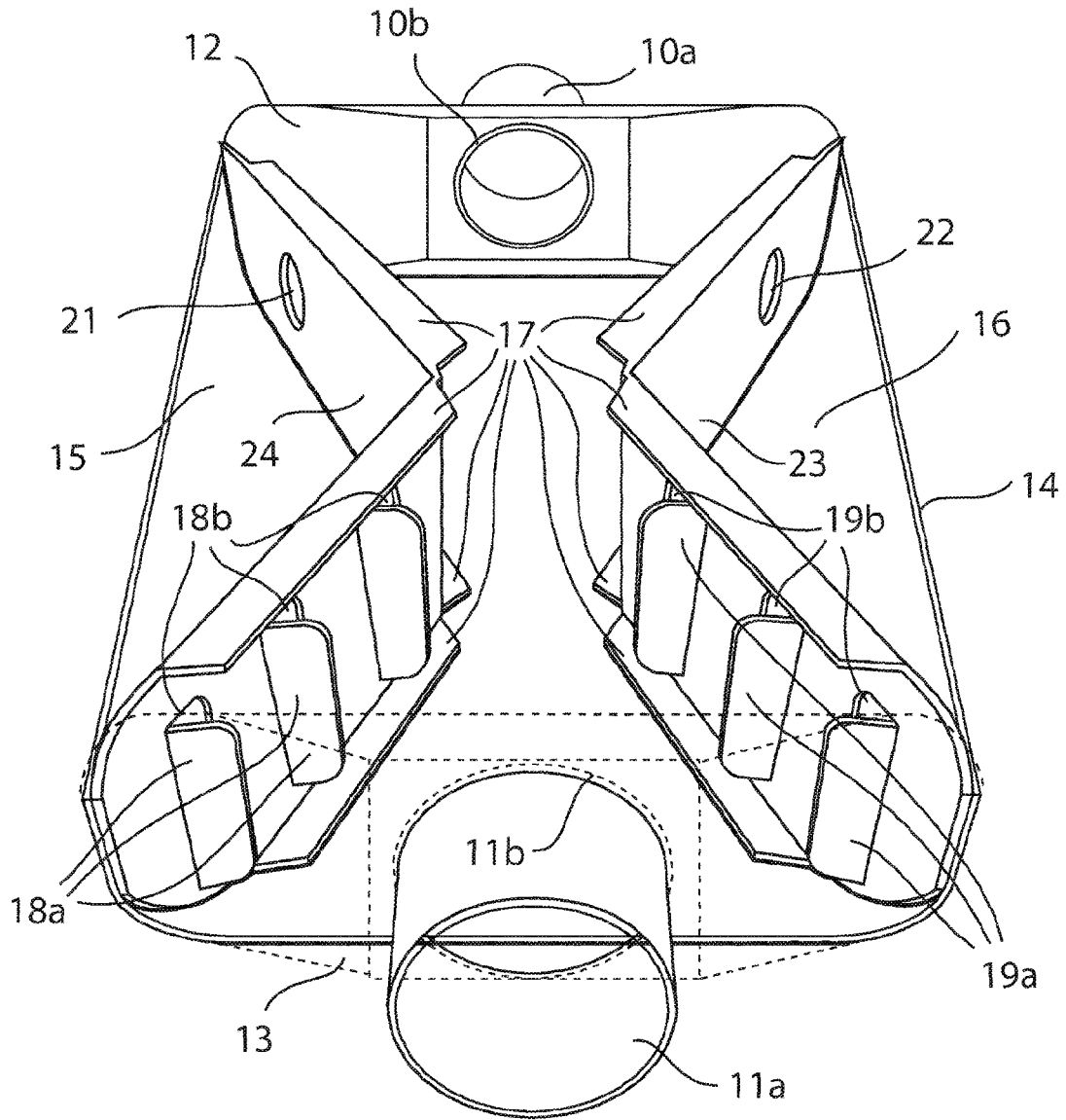

FIG. 4

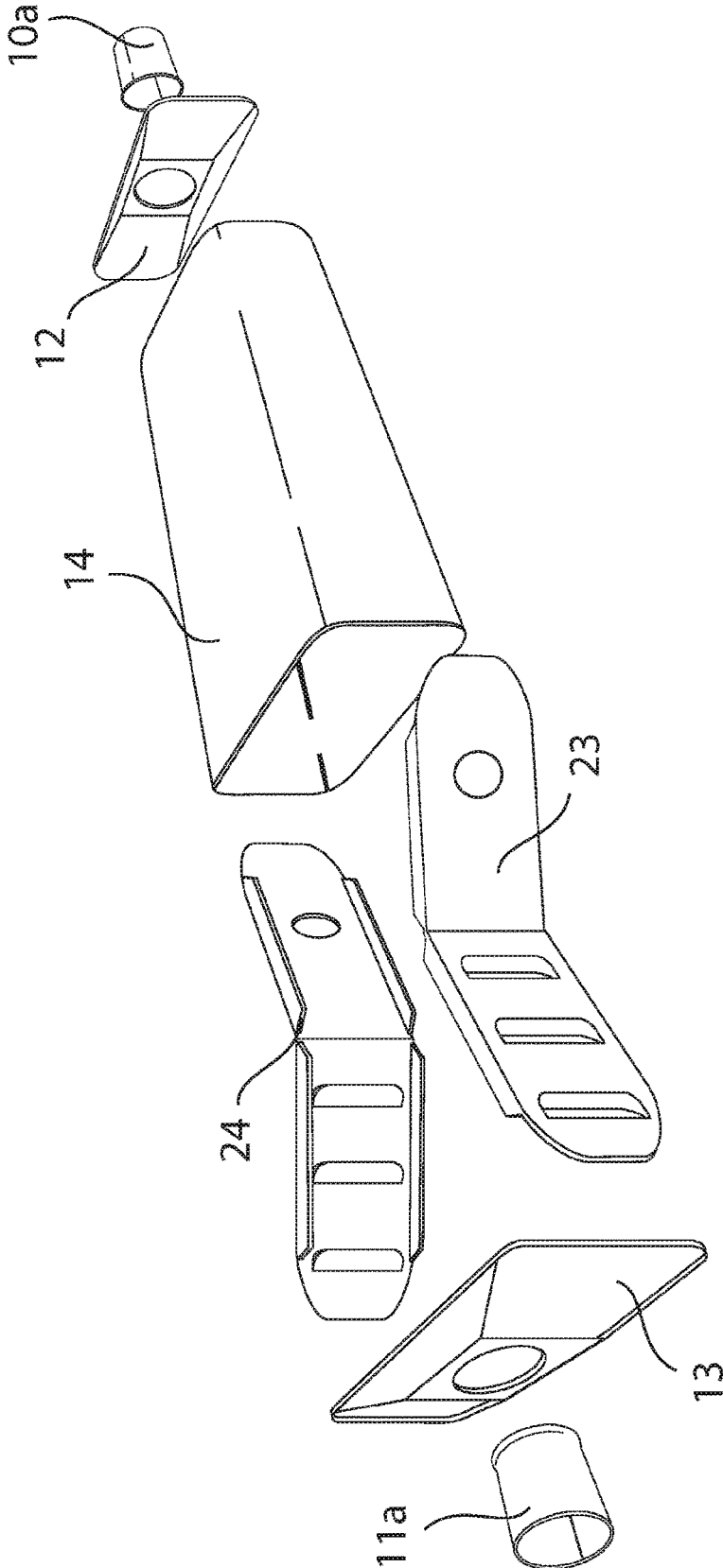

FIG. 5

1

**MUFFLER FOR AUTOMOBILE**CROSS-REFERENCE TO RELATED  
APPLICATIONS

This application is a continuation of U.S. patent application Ser. No. 13/761,038 filed Feb. 6, 2013 and entitled "Muffler for Automobile," which claims the benefit of U.S. Provisional Patent Application Ser. No. 61/956,088, filed Feb. 7, 2012 and entitled "Muffle for Automobile."

## BACKGROUND

The present application relates to the field of exhaust mufflers and, more particularly, to automotive mufflers. Automotive mufflers are created using different methods to channel gas exhaust through exhaust pipes in order to displace and muffle engine sound. Because of their complexity, many of these methods are over-thought and over-designed resulting in restricted performance and efficiency to the engine. Most engines perform at maximum capacity when exhaust airflow is not restricted. Mufflers that contain multiple and complex baffles to channel exhaust airflow create backflow pressure to the engine causing loss of performance and efficiency. Complex baffle designs can be expensive and complicated to manufacture. Other designs use packing, which typically consists of a fiberglass material placed within the muffler to displace sound. Due to extreme temperatures produced from the engine to the muffler, packing eventually hardens and breaks down, thus creating undesirable sound and ultimately the need for replacement.

## SUMMARY

In one aspect, the disclosure provides baffles permanently contained in a fixed location within the muffler body allowing for direct airflow through the muffler chamber resulting in increased performance and efficiency from the engine. Due to the simplicity of the design, the manufacturing process is simple to achieve and requires minimal labor effort to assemble.

## BRIEF DESCRIPTION OF THE DRAWINGS

FIG. 1A is a top partially cut away view showing an automotive muffler according to one embodiment.

FIG. 1B shows a portion of another embodiment of an automotive muffler.

FIG. 1C is a side view of the arrangement of FIG. 1A.

FIG. 1D is another side view of the arrangement of FIG. 1A.

FIG. 2 is an isometric view of internal components of the automotive muffler of FIG. 1A.

FIG. 3 is a top, partially-cut away view of another embodiment of an automotive muffler.

FIG. 4 is an assembled isometric view of the automotive muffler of FIG. 3.

FIG. 5 is an exploded isometric view of the automotive muffler of FIG. 3.

## DETAILED DESCRIPTION

FIGS. 1A, 1C, 1D and 2 illustrate one embodiment of an automotive muffler for the exhaust system of a gas combustion engine. FIG. 1A is a top view of the automotive muffler, which can be made of a metal, such as steel or stainless steel. In the illustrated embodiment, the automotive muffler has a

2

muffler casing or body 14 which includes an exhaust inlet end cap 12 and an opposing exhaust outlet end cap 13. An outer wall 140 extends between the end caps 12, 13. The end caps 12, 13 can be joined to opposite ends of the outer wall 140 such as by welding. In the illustrated embodiment, the muffler body 14 has an elongated, rectangular box-like structure and can have rounded longitudinal edges. A center muffler chamber 17 is formed within the muffler body 14.

An exhaust pipe inlet 10a can be joined to the inlet end cap 12 by inserting the exhaust pipe inlet 10a through a hole in the inlet end cap 12 and then welded to the inlet end cap 12 via an exhaust pipe inlet flange 10b. Similarly, an exhaust pipe outlet 11a is joined to the outlet end cap 13 by first inserting the exhaust pipe outlet 11a through a hole in the outlet end cap 13 and then welding an exhaust pipe outlet flange 11b to the outlet end cap 13. The exhaust pipe inlet 10a, the first end cap 12, the exhaust pipe outlet 10b, and the second end cap 13 can be made of metal. Gas exhaust can follow an exhaust flow path E entering the automotive muffler through the exhaust pipe inlet 10a and exiting through the exhaust pipe outlet 11a. The exhaust pipe inlet 10a and the exhaust pipe outlet 11a can be substantially aligned along the longitudinal axis of the muffler body 14. The exhaust flow path E can extend in a straight line from the exhaust pipe inlet 10a to the exhaust pipe outlet 11a, uninterrupted by any internal structure within the muffler body 14.

With continued reference to FIGS. 1A, C & D and 2, a baffle 23 having an upstream portion and a downstream portion is enclosed within the muffler body 14. The illustrated baffle 23 is elongated, has top and bottom surfaces, and opposite ends extending the full length of the muffler body 14. An upstream end of the baffle 23 is attached at a first corner of the muffler body 14 where the inlet end cap 12 meets the outer wall 140. A downstream end of the baffle is attached at a second corner of the muffler body 14 where the outlet end cap 13 meets the outer wall 140. FIG. 1B shows another embodiment in which the ends of the baffle 23 are not attached to the muffler body 14 at the first and second corners, but instead are attached to the ends caps at locations spaced from the associated corner in order to fit different muffler casing designs.

The baffle 23 can be made of any material, such as metal, including 14 gauge steel or stainless steel. The baffle 23 preferably is attached to the muffler body 14 along the entirety of both the top and bottom surfaces, preferably by top and bottom welds that each extend the complete length of the baffle 23. Preferably the ends of the baffle 23 are attached along their complete height, preferably by welds that extends the entire height of the ends.

The length of the baffle can be between 14 inches to 16 inches or any length, depending on the application and design. The height of the baffle 23 can be around 4 inches to 5 inches or any height, depending on the application and design.

As best shown in FIG. 1A, the upstream portion and the downstream portion of the baffle 23 can be separated by a bend in the baffle 23. As shown, the upstream portion extends from the upstream end cap in a direction transverse to the longitudinal axis so as to narrow the exhaust flow path E. The downstream portion extends from the bend to the downstream end cap also in a direction transverse to the longitudinal axis but oriented so as to broaden the exhaust flow path.

The baffle 23 cooperates with the outer wall 140 to define a sound cancelling chamber, or baffle chamber 16 within the muffler body 14, which baffle chamber 16 is separated from



the muffler chamber 17 by the baffle 23. In the illustrated embodiment, the baffle chamber 16 is generally triangular in shape.

A baffle upstream sound hole or upstream aperture 22a is formed through the upstream portion. A downstream sound hole or aperture 22b is formed through the downstream portion of the baffle 23. In the illustrated embodiment of FIG. 1, and as shown in FIGS. 1C and 1D, the upstream and downstream apertures 22a, 22b are each a circular hole about 1 1/4 inches in diameter located approximately midway along the upstream portion and midway along the downstream portion. The location, size, shape, and number of the apertures 22a, 22b can change based on application and design.

With continued reference to FIGS. 1A and 2, the apertures 22a, 22b are designed to trap and muffle sound. Since the baffle 23 is connected along its top and bottom and at its ends, the baffle sound holes preferably are the only air pathways into and out of the sound cancelling chamber 16. As shown, preferably a portion of the sound associated with exhaust follows a sound travel path S into the muffler chamber 17 through the inlet pipe 10a, and then into the sound cancelling chamber 16 through the upstream baffle aperture 22a. Sound is trapped and muffled in the chamber 16, and exits back into the muffler chamber 17 via the downstream baffle aperture 22b and exits the muffler via the outlet pipe 11a.

With continued reference to FIGS. 1A, B & C and 2, a second baffle 24 that mirrors the first baffle 23 can be placed opposite the longitudinal axis of the muffler body 14. The second baffle 24 would also have an upstream and a downstream portion, one or more upstream apertures 21a, one or more downstream apertures 21b, further divide the muffler chamber 17 into a smaller muffler chamber 17 and another baffle chamber 15, and define a sound pathway S through the baffle chamber 15.

In the illustrated embodiment, the muffler chamber 17 is generally hourglass-shaped, having wide portions at or adjacent the inlet and the outlet portions of the muffler body 14. A narrowed portion of the muffler chamber 17 is defined between the bends of the baffles 23, 24. Preferably the narrowed portion is substantially midway along the length of the muffler body 17 such that the upstream portions and the downstream portions of the baffles 23, 24 have approximately the same length. In one embodiment, the narrowed portion is about 5 inches wide, but this width can vary depending on application, baffle angle, and muffler body width. In the illustrated embodiment, the narrowed portion is the narrowest space along the length of the exhaust pathway E.

FIGS. 3-5 illustrate another embodiment of an automotive muffler having a casing or muffler body 14 enclosing a muffler chamber 17. An exhaust inlet pipe 10a extends through an end cap 12 to deliver exhaust to the muffler chamber 17. Exhaust exits the chamber 17 through an exhaust outlet pipe 11a that extends through an end cap 13. A baffle 23 within the body 14 defines a baffle chamber 16 that is separated from the muffler chamber 17. A baffle 24 is a minor image of baffle 23 and defines a baffle chamber 15 that is separated from the muffler chamber 17. As such, the muffler chamber 17 has an hourglass shape. Weld supports 20 along the longitudinal top and bottom of each baffle can be welded to the interior of the muffler body 14.

The illustrated baffles 23, 24 each have one upstream sound hole 22, 21, formed through an upstream portion of the respective baffle. Each baffle also has three downstream sound holes 19b, 18b formed through a downstream portion

of each baffle, which downstream portion is defined as the part downstream along the exhaust flow path from the narrowest part of the hourglass shape. In the illustrated embodiment, the upstream sound holes 21, 22 are each circular, and are each located off center of the upstream portion of the baffle 23, 24. More specifically, the upstream holes are located somewhat forward of the center of each upstream portion.

With continued reference to FIGS. 3-5, in the illustrated embodiment, the downstream apertures 18b, 19b are generally rectangular, and each have an adjacent latitudinal louver 18a, 19a extending from a downstream edge of the associated downstream aperture 18b, 19b. In the illustrated embodiment, each louver extends in a direction away from the baffle chambers 15, 16 into the muffler chamber 17. The illustrated louvers 18a, 19a are generally straight and extend in a direction transverse to the longitudinal axis. In the illustrated embodiment, the louvers 18a, 19a extends in a direction generally towards the exhaust pipe inlet 10a. The louvers 18a, 19a can be formed by partially punching out the downstream apertures 18b, 19b and bending the louvers 18a, 19a at the downstream edge of the downstream apertures 18b, 19b.

In accordance with one embodiment, a method for making an automotive muffler as in FIGS. 3 and 4 is provided. In accordance with the embodiment, a metal such as steel or stainless steel is cut to create the muffler body 14. The steel is bent longitudinally to form a uniform muffler body 14 and muffler chamber 17. The formed muffler body 14 is then welded on the exterior of one side to create a solid muffler body 14. The formed muffler body 14 can be sealed by creating a weld along one side of the longitudinal length of the formed muffler body 14. Two baffles 23, 24 are cut out of steel or stainless steel, then bent at equal locations creating the initial stages of the baffle chambers (-15, 16-). Baffle weld supports (-20-) are then bent outward toward the center of the muffler chamber (-17-) and welded to the muffler body (-14-). The baffles 23, 24 can be secured to the muffler body 14 by multiple welds along the weld support locations. The baffles can also be secured to the muffler body by multiple weld locations along the inside latitudinal edge. The exhaust inlet pipe 10a and exhaust outlet pipe 11a can be joined to respective end caps 12, 13 by first inserting the exhaust inlet and outlet pipes 10a, 11a, through hole in the associated end caps 12, 13 and then welding the pipes to the end caps via associated exhaust pipe flanges 10b, 11b. The end caps 12, 13 can then be welded to the respective ends of the muffler body 14.

What is claimed is:

1. An automotive muffler, comprising:
  - an elongated body having an axis and defining a muffler chamber therewithin, the muffler chamber extending along the axis;
  - an exhaust inlet and an exhaust outlet which are each formed in the body and communicate with the muffler chamber, an exhaust flow path extending between the exhaust inlet and the exhaust outlet; and
  - at least one baffle having:
    - a peripheral surface that is attached to and abuts the body along the length of the baffle so that a baffle chamber is defined between the baffle and a portion of the body, the baffle chamber being separated from the muffler chamber by the baffle, with the muffler chamber being defined between the baffle and a portion of the body;
    - an upstream portion extending in a direction transverse to the axis so as to narrow the exhaust flow path;

5

- a downstream portion extending in a direction transverse to the axis so as to broaden the exhaust flow path, the upstream and downstream portions being contiguous and meeting at a baffle bend;
- at least one upstream aperture formed through the upstream portion so as to facilitate communication between the muffler chamber and the baffle chamber; and
- at least one downstream aperture formed through the downstream portion so as to facilitate communication between the baffle chamber and the muffler chamber.
2. The automotive muffler as in claim 1, wherein the exhaust flow path follows a straight line from the exhaust inlet to the exhaust outlet.
3. The automotive muffler as in claim 1, wherein the baffle is formed to include a plurality of downstream apertures.
4. The automotive muffler as in claim 1, wherein: the upstream portion has an upstream distal end, and the upstream aperture is approximately centered between the upstream distal end and the bend; and the downstream portion has a downstream distal end, and the downstream aperture is approximately centered between the downstream distal end and the bend.
5. The automotive muffler as in claim 1, wherein the upstream portion is the same length as the downstream portion.
6. The automotive muffler as in claim 1, wherein the upstream aperture is circular, and the downstream aperture is non-circular.
7. The automotive muffler as in claim 6, further comprising at least one louver adjacent the downstream aperture, the louver extending from a downstream edge of the downstream aperture away from the baffle chamber and into the muffler chamber.
8. The automotive muffler as in claim 7, wherein the louver is straight and extends in a direction transverse to the axis.
9. The automotive muffler as in claim 7, wherein: the baffle is formed to include a plurality of downstream apertures; and a plurality of louvers are adjacent respective ones of the downstream apertures.
10. The automotive muffler as in claim 1, wherein the peripheral surface of the baffle is attached to the body by elongated weld supports.
11. The automotive muffler as in claim 1, wherein the body has a generally rectangular cross-section as viewed perpendicular to the axis.
12. The automotive muffler as in claim 11, wherein the body has opposed top and bottom walls, with the muffler chamber and the baffle chamber each extending between portions of the top and bottom walls.
13. The automotive muffler as in claim 1 further comprising: a second baffle having: a peripheral surface that is attached to and abuts the body along the length of the second baffle so that a second baffle chamber is defined between the second baffle and a portion of the body, the second baffle chamber being separated from the muffler chamber by the second baffle such that the muffler chamber is defined between the baffle, the second baffle and a portion of the body; an upstream portion extending in a direction transverse to the axis so as to narrow the exhaust flow path;

6

- a downstream portion extending in a direction transverse to the axis so as to broaden the exhaust flow path, the upstream and downstream portions being contiguous and meeting at a second baffle bend;
- at least one upstream aperture formed through the upstream portion so as to facilitate communication between the muffler chamber and the second baffle chamber; and
- at least one downstream aperture formed through the downstream portion so as to facilitate communication between the second baffle chamber and the muffler chamber.
14. The automotive muffler as in claim 13, wherein the second baffle mirrors the baffle about the axis of the body.
15. The automotive muffler as in claim 13, wherein the baffle chamber and second baffle chamber are each generally triangular.
16. An automotive muffler, comprising: an elongated body having an axis and defining a muffler chamber therewithin, the muffler chamber extending along the axis; an exhaust inlet and an exhaust outlet which are each formed in the body and communicate with the muffler chamber, an exhaust flow path extending between the exhaust inlet and the exhaust outlet; and at least one baffle having: a peripheral surface that is attached to the body so that a baffle chamber is defined between the baffle and a portion of the body, the baffle chamber being separated from the muffler chamber by the baffle; an upstream portion extending in a direction transverse to the axis so as to narrow the exhaust flow path; a downstream portion extending in a direction transverse to the axis so as to broaden the exhaust flow path, the upstream and downstream portions meeting at a baffle bend; at least one upstream aperture formed through the upstream portion so as to facilitate communication between the muffler chamber and the baffle chamber; and at least one downstream aperture formed through the downstream portion so as to facilitate communication between the baffle chamber and the muffler chamber; wherein the baffle chamber collectively defined by the baffle and the body is generally triangular.
17. The automotive muffler as in claim 16 further comprising a second baffle arranged within the body so as to mirror the baffle about the axis, the second baffle having: a peripheral surface that is attached to the body so that a second baffle chamber is defined between the second baffle and a portion of the body, the second baffle chamber being separated from the muffler chamber by the second baffle; an upstream portion extending in a direction transverse to the axis so as to narrow the exhaust flow path; a downstream portion extending in a direction transverse to the axis so as to broaden the exhaust flow path, the upstream and downstream portions meeting at a second baffle bend; at least one upstream aperture formed through the upstream portion so as to facilitate communication between the muffler chamber and the second baffle chamber; and at least one downstream aperture formed through the downstream portion so as to facilitate communication between the second baffle chamber and the muffler chamber;

wherein the second baffle chamber collectively defined by the second baffle and the body is generally triangular.

**18.** The automotive muffler as in claim **17**, wherein the baffle and second baffle are arranged in an hourglass configuration when viewed from a top or a bottom of the body, 5 but not when viewed from a side of the body.

**19.** The automotive muffler as in claim **18**, wherein the body has a generally rectangular cross-section as viewed perpendicular to the axis.

**20.** The automotive muffler as in claim **19**, wherein the 10 body has opposed top and bottom walls, with the muffler chamber, the baffle chamber, and the second baffle chamber each extending between portions of the top and bottom walls.

\* \* \* \* \*