



US009936681B2

(12) **United States Patent**
Mancini

(10) **Patent No.:** **US 9,936,681 B2**
(45) **Date of Patent:** ***Apr. 10, 2018**

(54) **FISHING LURE SYSTEM AND KIT HAVING REPLACEABLE FEATURES AND CONSTRUCTION**

(56) **References Cited**

U.S. PATENT DOCUMENTS

(71) Applicant: **Jeffrey Mancini**, New Rochelle, NY (US)

3,490,165 A 1/1970 Thomassin
3,863,378 A 2/1975 Walker
(Continued)

(72) Inventor: **Jeffrey J. Mancini**, New Rochelle, NY (US)

FOREIGN PATENT DOCUMENTS

(73) Assignee: **Jeffrey Mancini**, New Rochelle, NY (US)

CA 2290903 5/2001
JP 11-196714 7/1999
WO WO 2005/115137 12/2005

(*) Notice: Subject to any disclaimer, the term of this patent is extended or adjusted under 35 U.S.C. 154(b) by 462 days.

OTHER PUBLICATIONS

This patent is subject to a terminal disclaimer.

Serial No. PCT/US08/61827 filed Apr. 28, 2007, International Search Report and Written Opinion of the International Searching Authority, 12 pages.

(Continued)

(21) Appl. No.: **14/754,871**

Primary Examiner — Christopher P Ellis

(22) Filed: **Jun. 30, 2015**

(74) *Attorney, Agent, or Firm* — Andrew F. Young, Esq.; Lackenbach Siegel, LLP

(65) **Prior Publication Data**

US 2017/0000096 A1 Jan. 5, 2017
US 2017/0325437 A9 Nov. 16, 2017

(57) **ABSTRACT**

Related U.S. Application Data

(63) Continuation of application No. 13/916,211, filed on Jun. 12, 2013, now Pat. No. 9,095,128, which is a (Continued)

A flexible fishing lure is provided that includes a outer shape having a transverse opening for receiving a plurality of alternatively formed lure fin members allowing a user to change the action of a lure by fin selection without replacing the lure. Multiple internal channels within the lure are adaptively provided for receiving a variety of scent sticks, sound generators, light generators, flavor generating means. Flow internal channels extend from a front opening to gill openings allowing a water flow along an inserted scent or flavor stick member to pass through the lure body and exit proximate fin, nair, belly, or other locations simulating an injured or wounded fish leaking bodily fluids or blood. Other features to simulate wounded features. Replacement fins and weighting constructions allow a user to tailor a weight and action enabling a circling or injured motion during retrieval. The lure includes a flexible holographic-type attractive film and physical shape having a level-maintaining physical shape.

(51) **Int. Cl.**

A01K 85/18 (2006.01)
A01K 85/16 (2006.01)
(Continued)

(52) **U.S. Cl.**

CPC **A01K 85/18** (2013.01); **A01K 85/00** (2013.01); **A01K 85/01** (2013.01); **A01K 85/02** (2013.01); **A01K 85/16** (2013.01)

(58) **Field of Classification Search**

CPC A01K 85/18; A01K 85/01
See application file for complete search history.

6 Claims, 21 Drawing Sheets

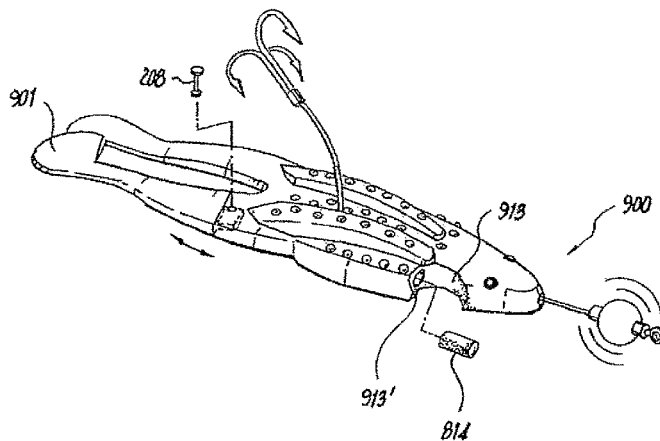

Related U.S. Application Data

continuation of application No. 12/525,979, filed as application No. PCT/US2008/061827 on Apr. 28, 2008, now Pat. No. 8,490,319.

- (60) Provisional application No. 60/914,230, filed on Apr. 26, 2007, provisional application No. 60/914,220, filed on Apr. 26, 2007, provisional application No. 60/914,223, filed on Apr. 26, 2007.

(51) **Int. Cl.**

A01K 85/02 (2006.01)
A01K 85/01 (2006.01)
A01K 85/00 (2006.01)

(56) **References Cited**

U.S. PATENT DOCUMENTS

3,967,406 A 7/1976 Anderson
 3,973,350 A 8/1976 England
 4,380,132 A 4/1983 Atkinson
 4,453,335 A 6/1984 Smith
 4,610,103 A 9/1986 Steinman
 4,638,584 A 1/1987 Lindsay
 4,672,768 A 6/1987 Pippert
 4,693,032 A 9/1987 Mattison
 4,709,499 A 12/1987 Ottaviano
 4,785,569 A 11/1988 Thomas, Jr.
 4,791,749 A 12/1988 Stazo
 4,823,497 A 4/1989 Pierce
 4,831,765 A 5/1989 Bradshaw
 5,038,512 A 8/1991 Rudolph
 5,119,581 A 6/1992 Rudolph
 5,193,299 A 3/1993 Correll et al.
 5,331,762 A 7/1994 Banks
 5,355,613 A 10/1994 Kechriotis
 5,517,781 A 5/1996 Paoletta et al.
 5,537,770 A 7/1996 Storm et al.
 5,566,494 A 10/1996 Zimmer
 5,661,921 A 9/1997 Mason
 5,678,349 A 10/1997 Pacora
 5,678,350 A 10/1997 Moore
 5,806,234 A 9/1998 Nichols
 5,862,623 A 1/1999 MacPherson
 5,894,693 A 4/1999 Davie
 5,953,849 A 9/1999 Boucher, Jr.
 6,041,540 A 3/2000 Potts
 6,182,391 B1 2/2001 Hubbard
 6,219,955 B1 4/2001 Hnizdor

6,266,916 B1 7/2001 Dugan
 6,301,823 B1 10/2001 Monticello et al.
 6,393,755 B1 5/2002 Weaver
 6,510,646 B1 1/2003 Kechriotis
 6,643,975 B1 11/2003 Edwards
 6,718,684 B2 4/2004 Yong-Set
 6,807,766 B1 10/2004 Hughes et al.
 6,857,220 B2 2/2005 King
 6,912,808 B1 7/2005 Mak
 6,922,937 B1 8/2005 Gilbert
 6,941,696 B2 9/2005 Kato
 7,080,476 B2 7/2006 King
 7,104,004 B1 9/2006 Renosky
 7,174,669 B1 2/2007 Kallas
 7,185,457 B2 3/2007 Nichols
 7,263,798 B2 9/2007 Nichols
 2001/0047609 A1 12/2001 Orgeron et al.
 2002/0007582 A1 1/2002 Coppola, Jr.
 2002/0043016 A1 4/2002 Kechriotis
 2002/0178643 A1 12/2002 Brodeur
 2002/0189150 A1 12/2002 Thorne
 2002/0194770 A1 12/2002 King
 2003/0024150 A1 2/2003 Hawkins
 2003/0110678 A1 6/2003 Yong-Set
 2003/0192227 A1 10/2003 Stava, III et al.
 2004/0025406 A1 2/2004 Kato
 2005/0126066 A1 6/2005 King
 2005/0172536 A1 8/2005 King
 2005/0204607 A1 9/2005 Nichols
 2005/0246941 A1 11/2005 Mitchell et al.
 2005/0252069 A1 11/2005 Pool et al.
 2006/0053679 A1 3/2006 Milangso
 2006/0143972 A1 7/2006 Nichols
 2006/0174535 A1 8/2006 Beer et al.
 2006/0236588 A1 10/2006 Rapelje
 2006/0260176 A1 11/2006 Yeung
 2006/0260177 A1 11/2006 Thomas
 2007/0062094 A1 3/2007 Senter
 2007/0119090 A1 5/2007 Searcy
 2007/0163165 A1 7/2007 Castro et al.
 2007/0175083 A1 8/2007 Wilson et al.

OTHER PUBLICATIONS

U.S. Appl. No. 14/628,240, filed Feb. 21, 2015.
 U.S. Appl. No. 13/916,211, filed Jun. 12, 2013.
 U.S. Appl. No. 12/525,979, filed Oct. 1, 2010 (U.S. Pat. No. 8,490,319).
 PCT Appln. S.N. PCT/US08/61827 filed Apr. 28, 2008.
 U.S. Appl. No. 60/914,230, filed Apr. 26, 2007.
 U.S. Appl. No. 60/914,220, filed Apr. 26, 2007.
 U.S. Appl. No. 60/914,223, filed Apr. 26, 2007.

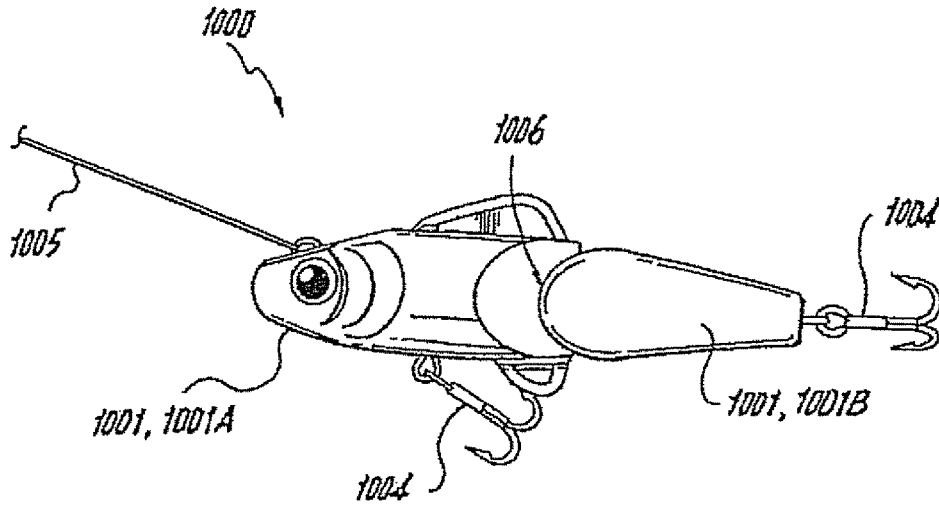

Fig. 1
(Prior Art)

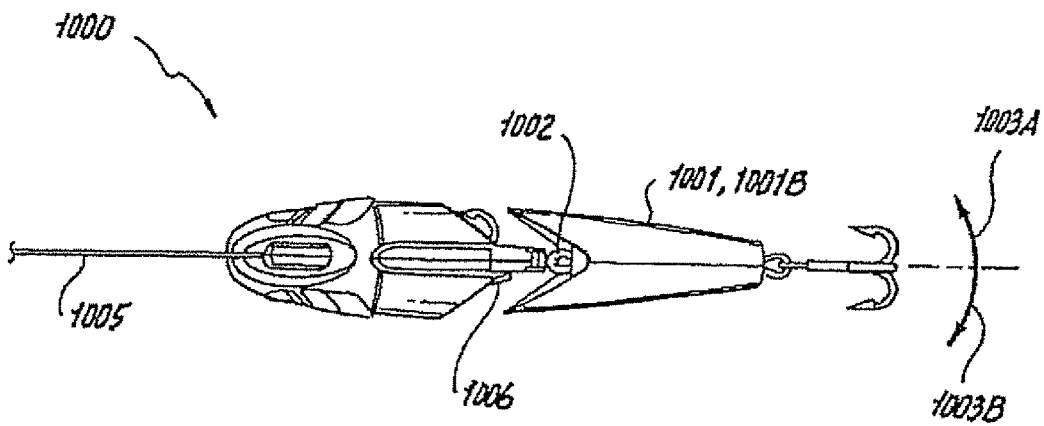

Fig. 2
(Prior Art)

Fig. 3
(Prior Art)

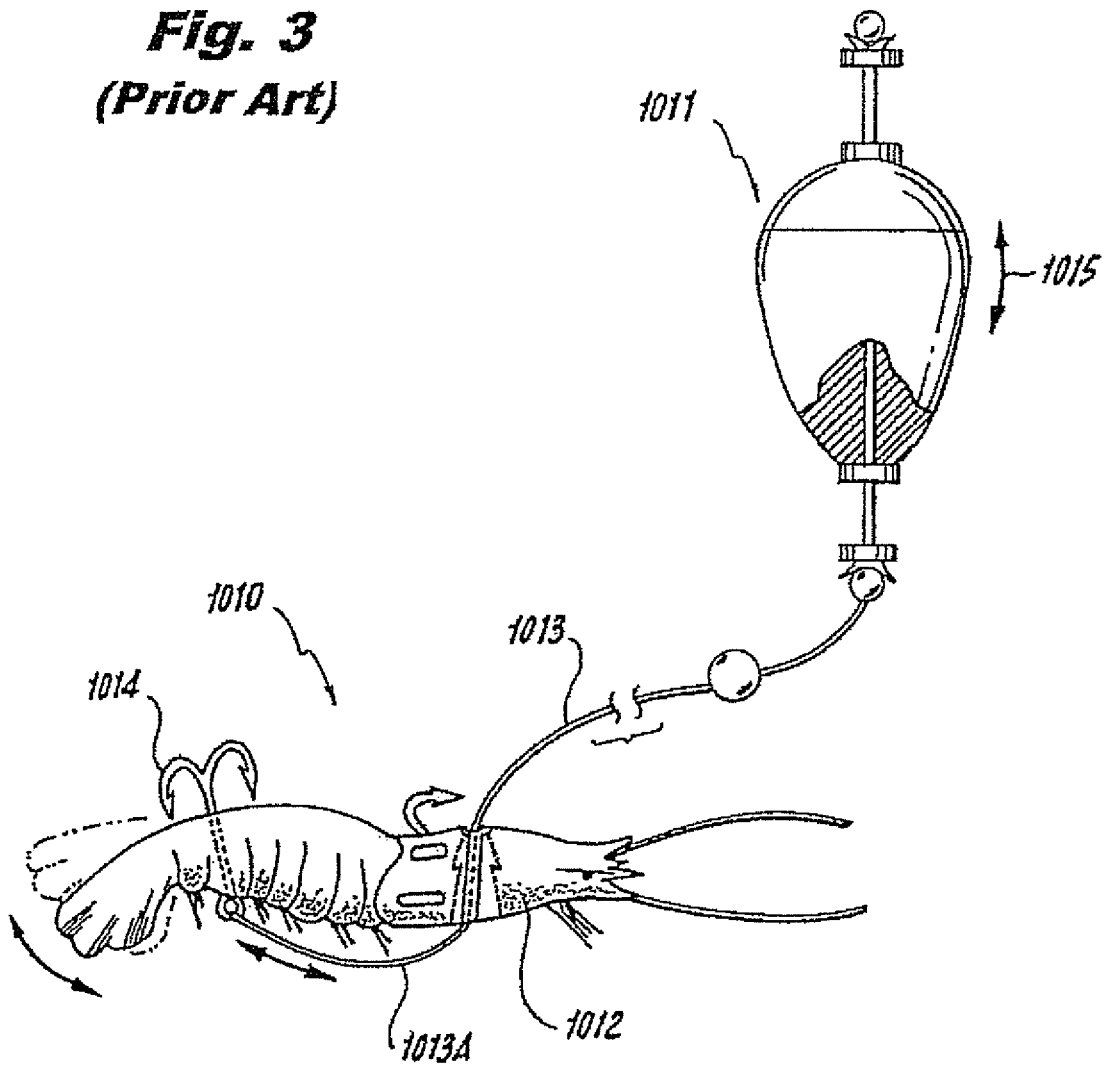

Fig. 4

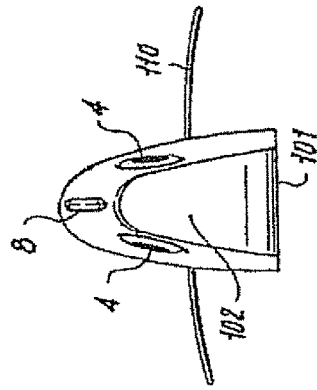
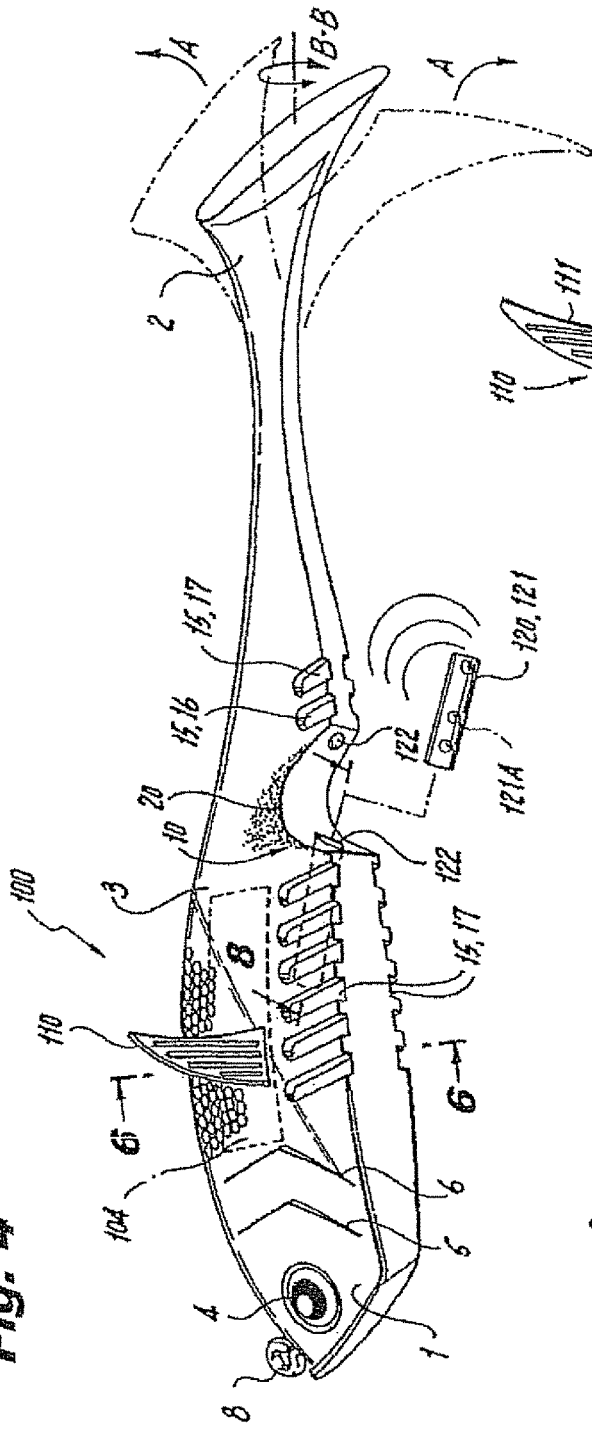

Fig. 5

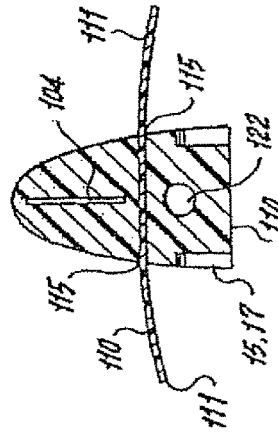

Fig. 6

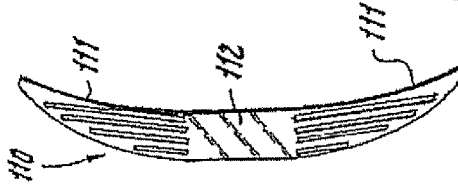

Fig. 7

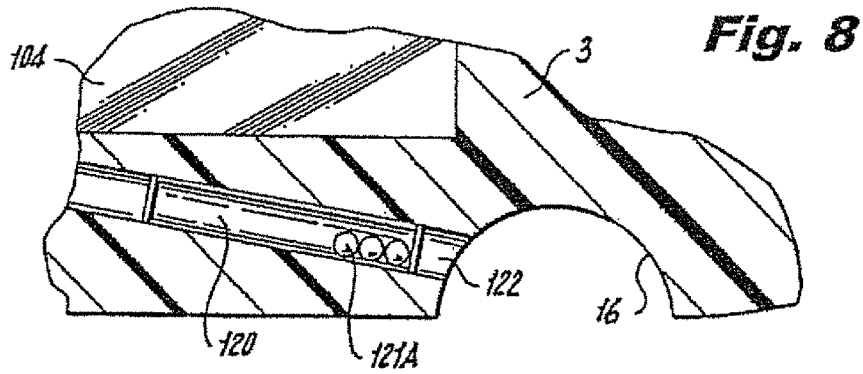

Fig. 8

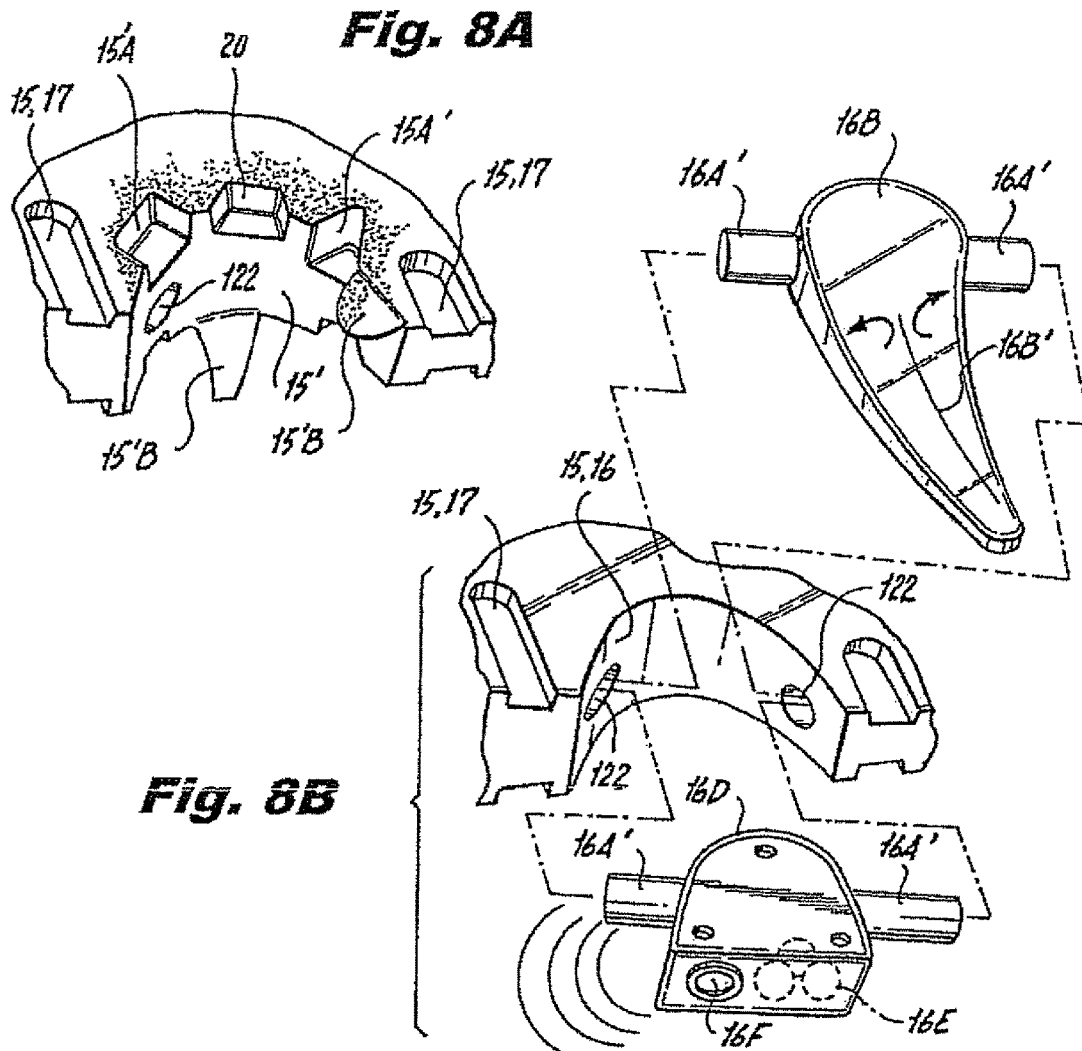

Fig. 8A

Fig. 8B

Fig. 9

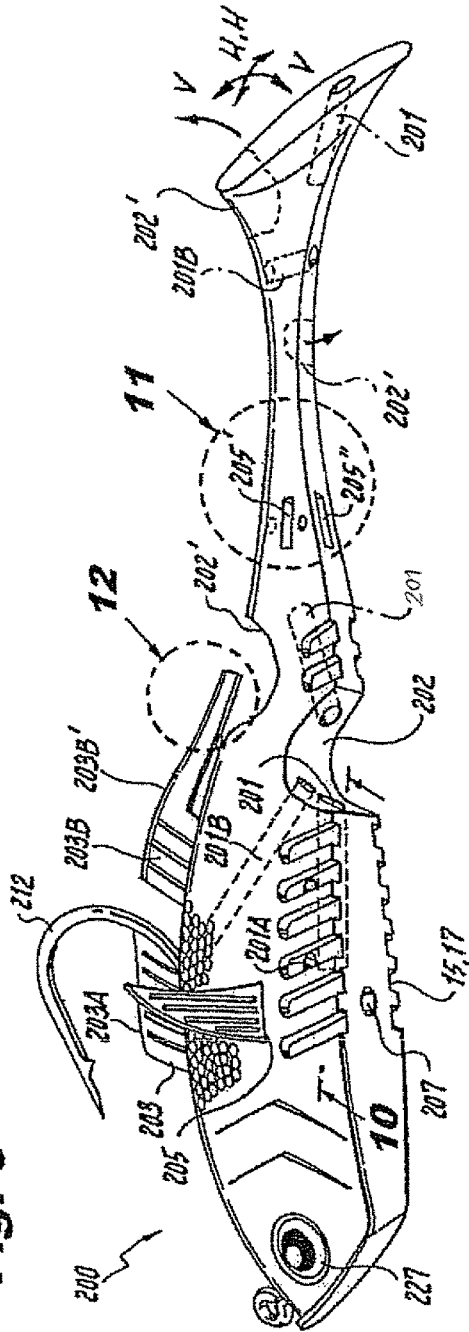

FIG. 11

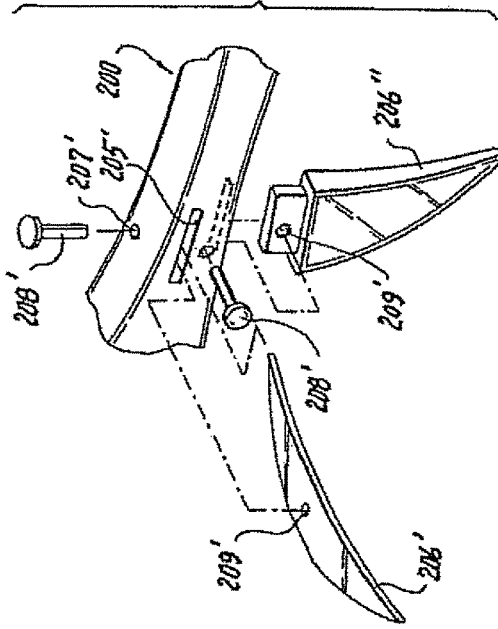
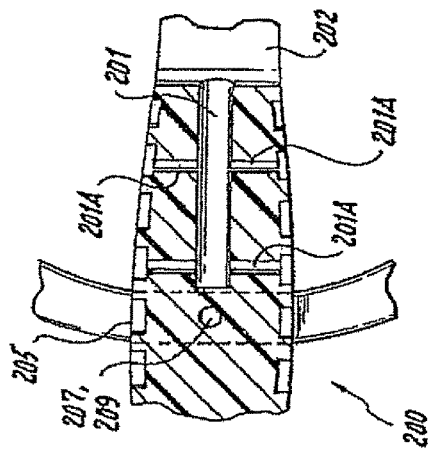

Fig. 10



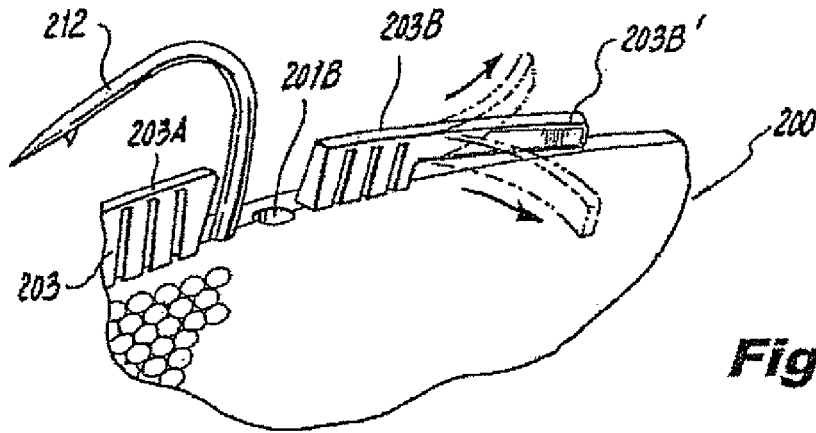

Fig. 12

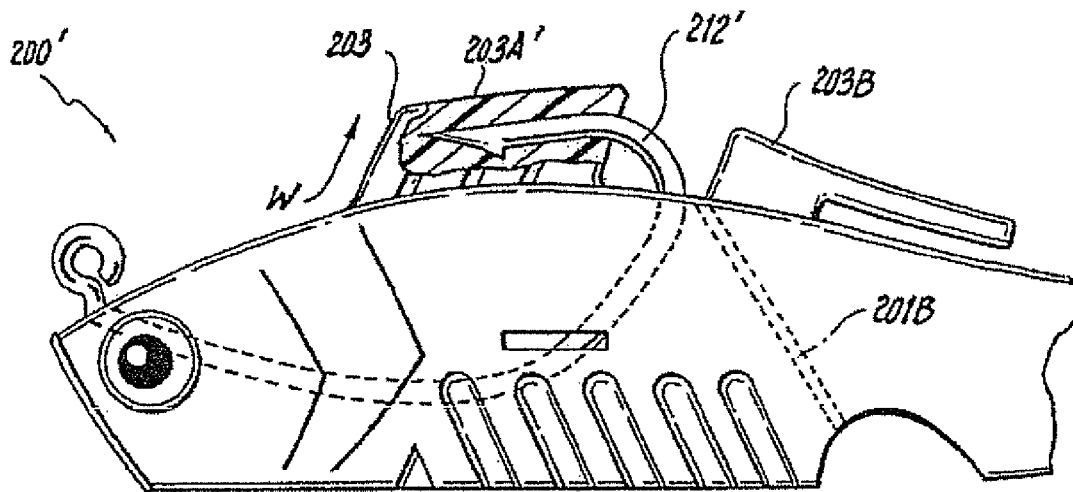

Fig. 13

Fig. 14

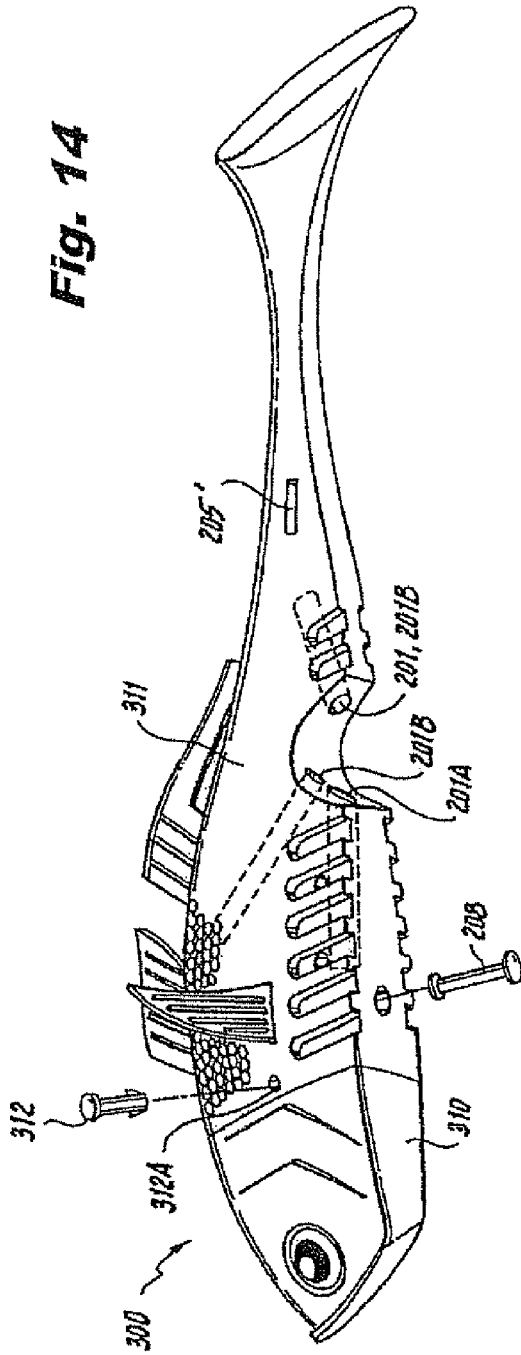

Fig. 14A

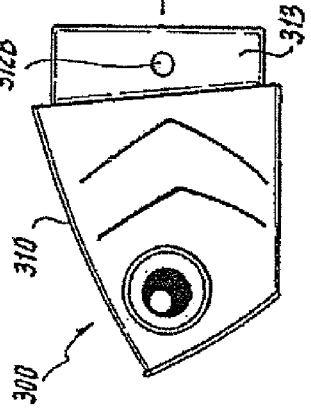

Fig. 14B

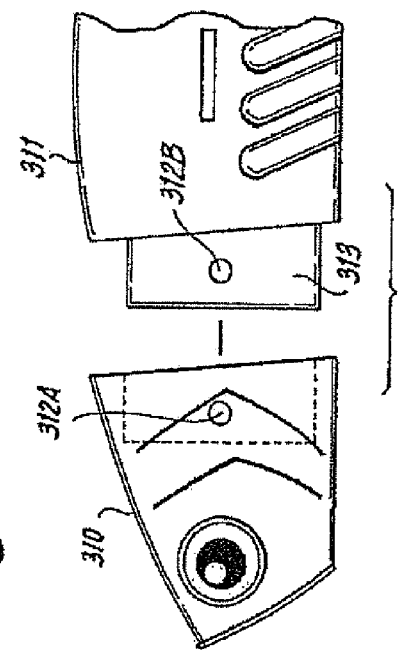

Fig. 14C

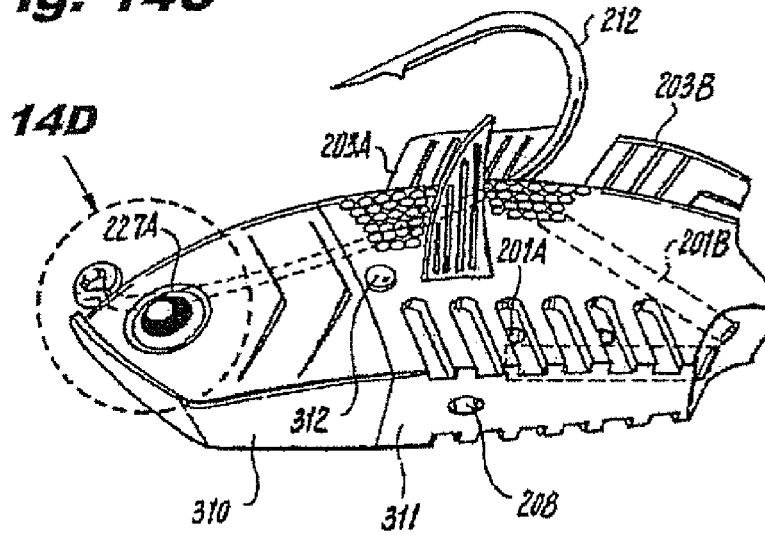

Fig. 15

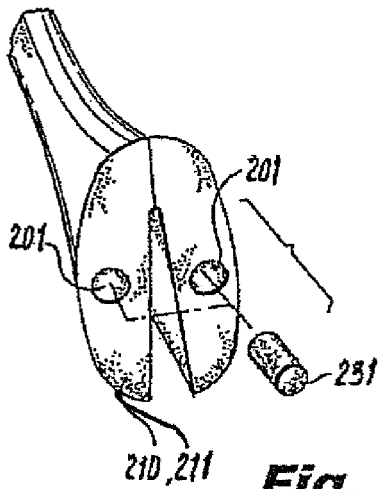
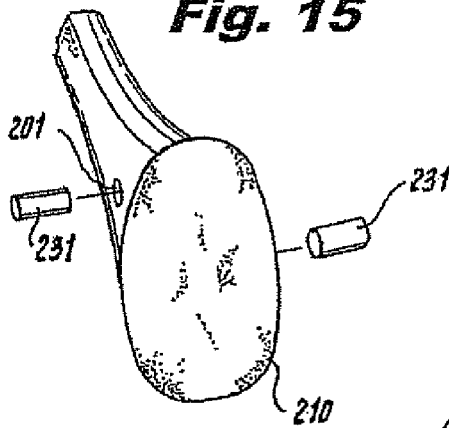
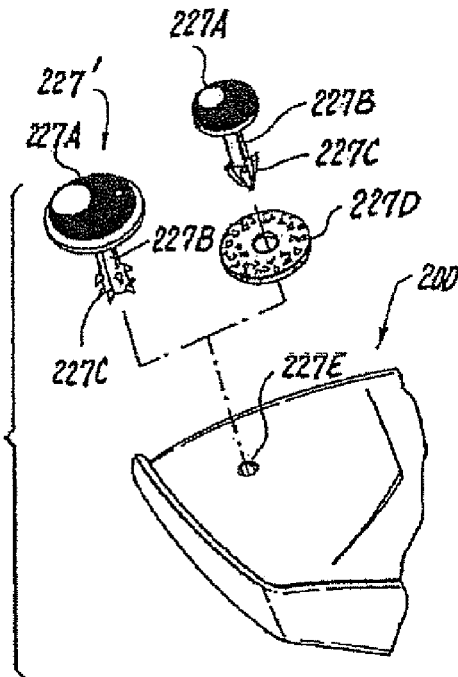

Fig. 15A

Fig. 14D



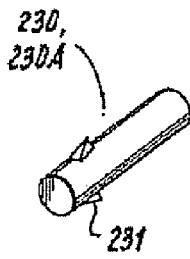

Fig. 15A



Fig. 15B

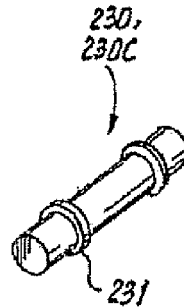

Fig. 15C

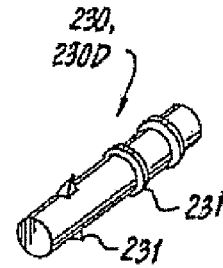

Fig. 15D

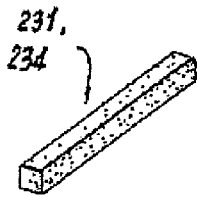

Fig. 16A

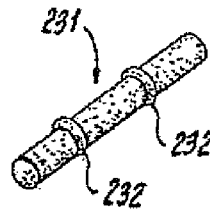

Fig. 16B

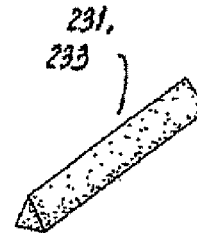

Fig. 16C

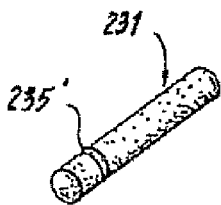

Fig. 16D

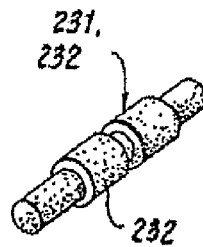

Fig. 16E

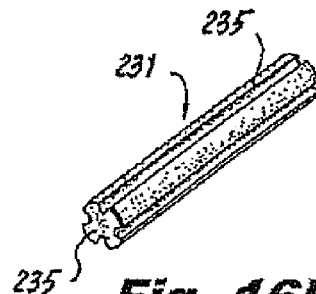

Fig. 16F

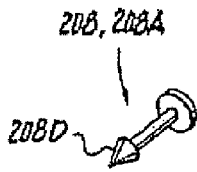

Fig. 17A

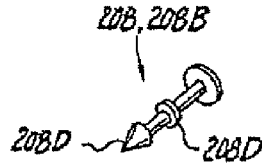

Fig. 17B

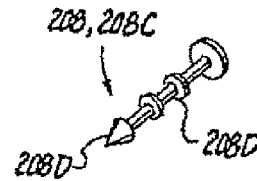

Fig. 17C

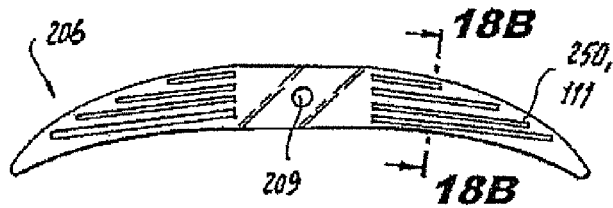

Fig. 18A

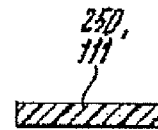

Fig. 18B

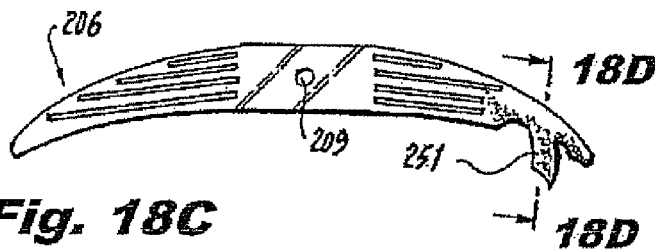

Fig. 18C

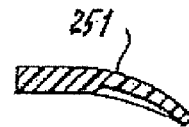

Fig. 18D

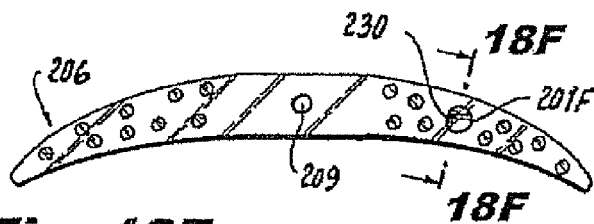

Fig. 18E



Fig. 18F

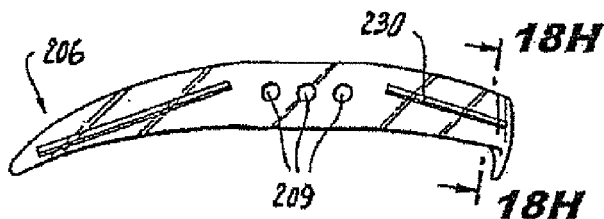

Fig. 18G

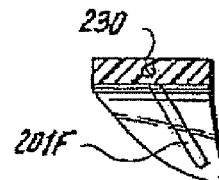

Fig. 18H

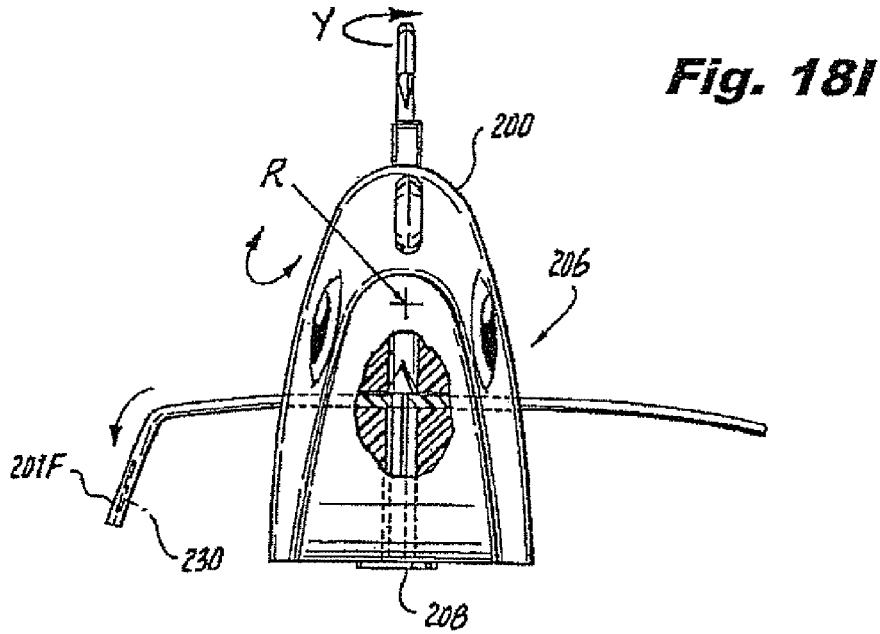

Fig. 18I

Fig 19A

Fig 19B

Fig. 19C

Fig. 19D

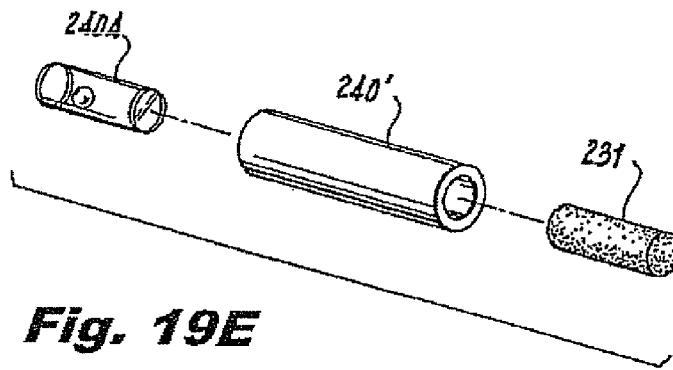
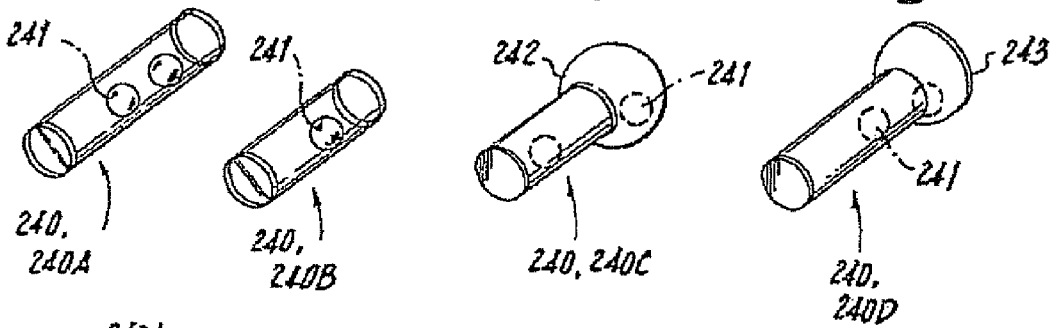

Fig. 19E

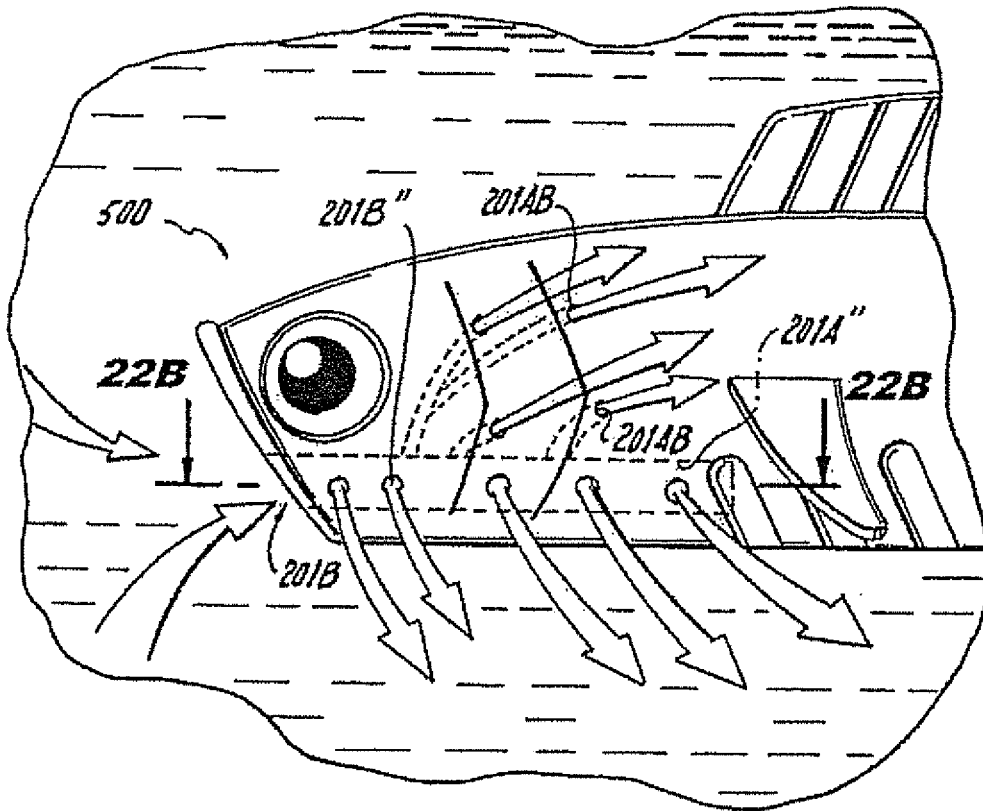

Fig. 22A

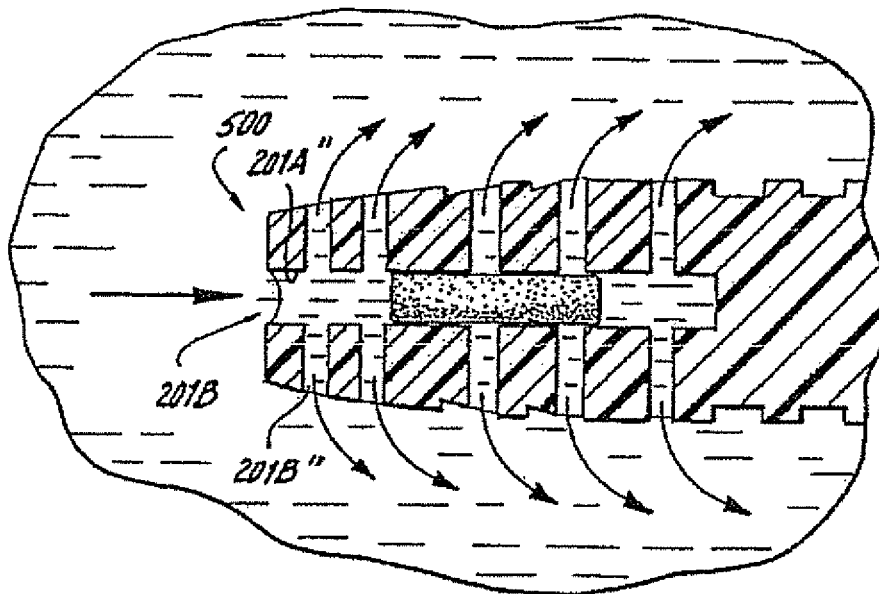

Fig. 22B

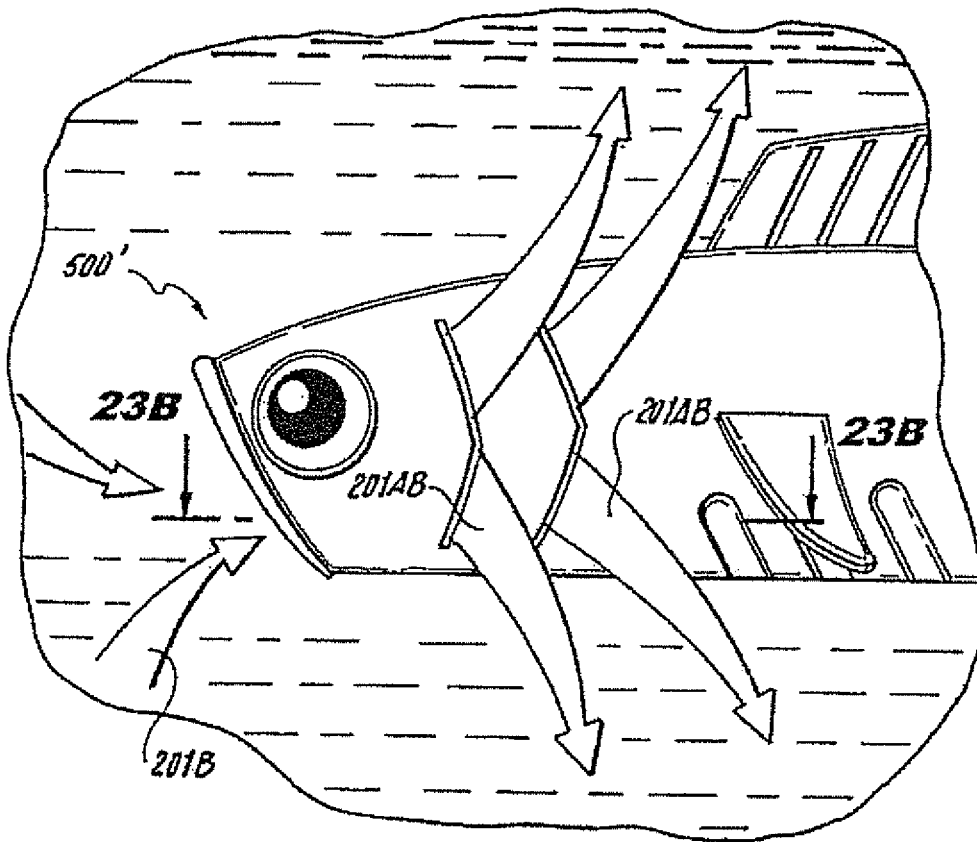

Fig. 23A

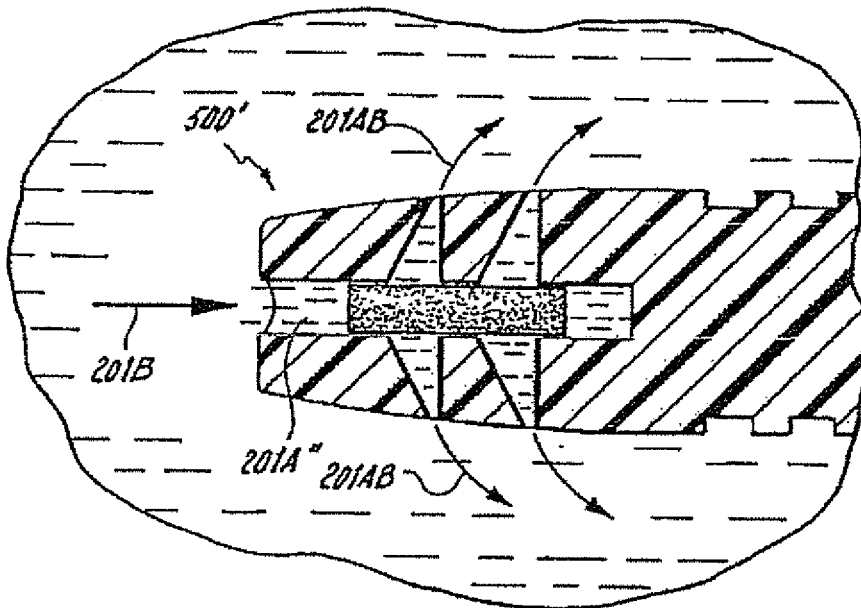

Fig. 23B

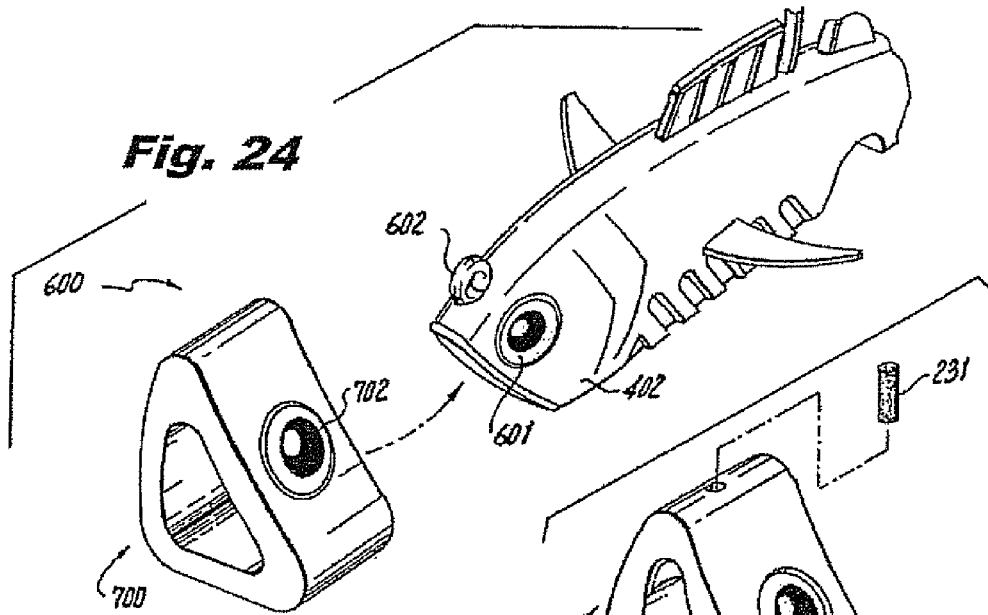

Fig. 25A

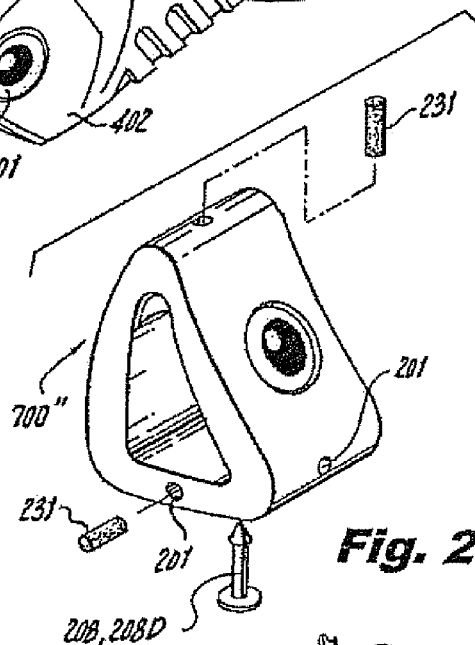
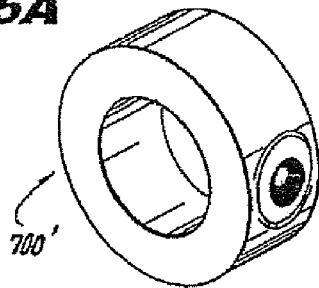

Fig. 25B

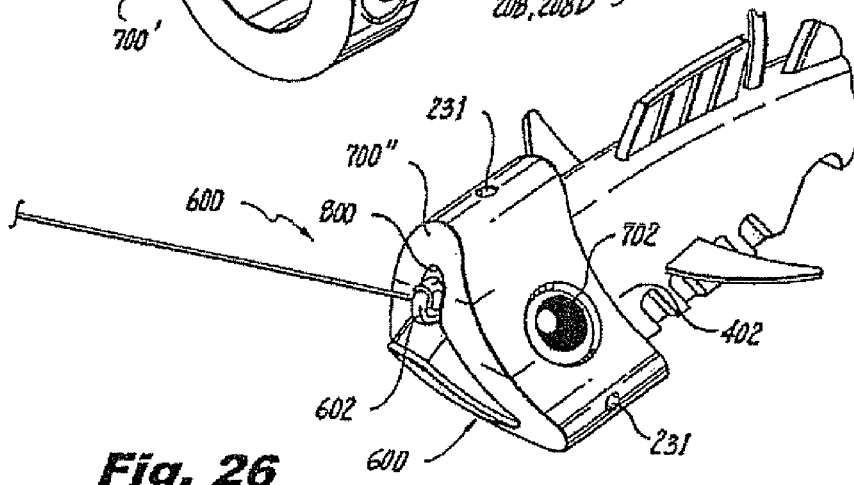

Fig. 26

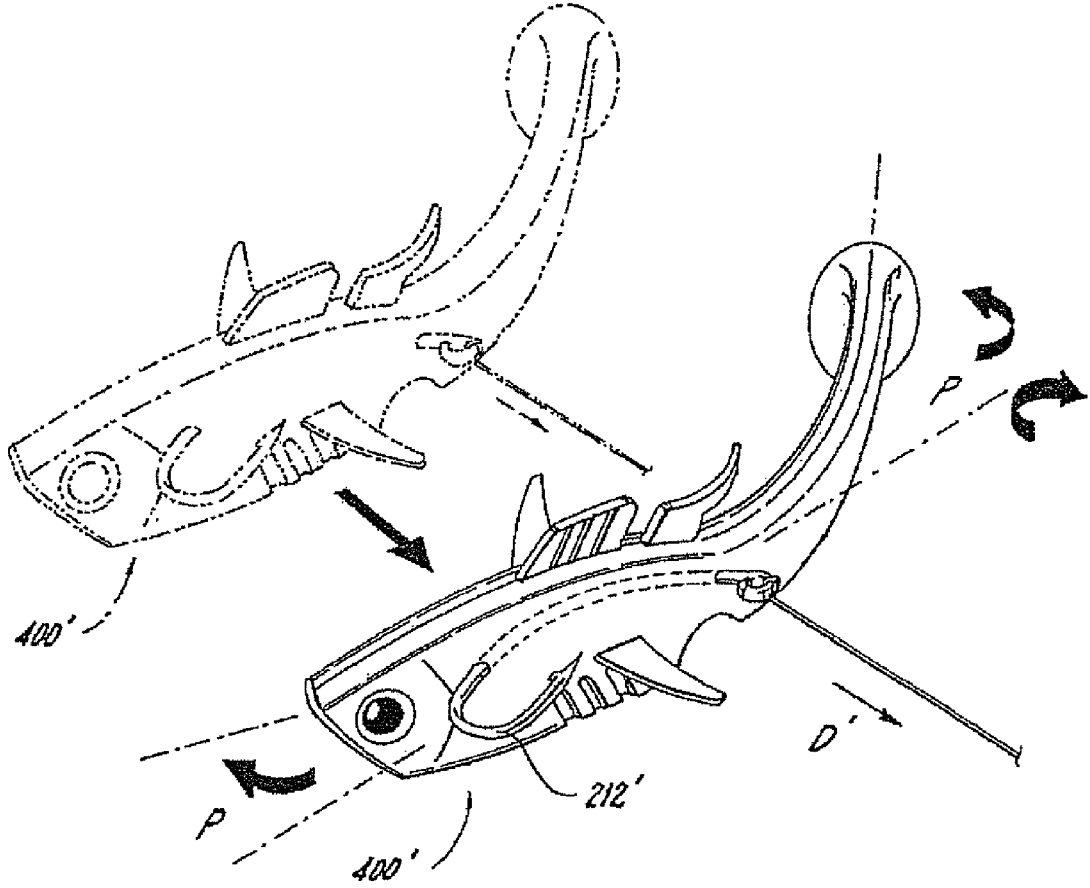

Fig. 27

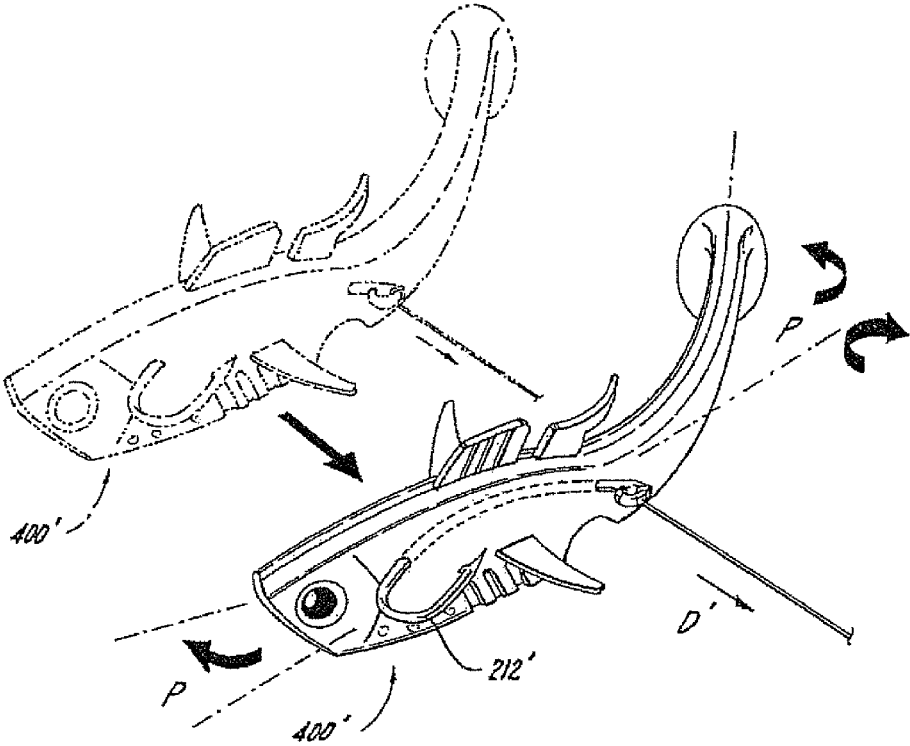

Fig. 28

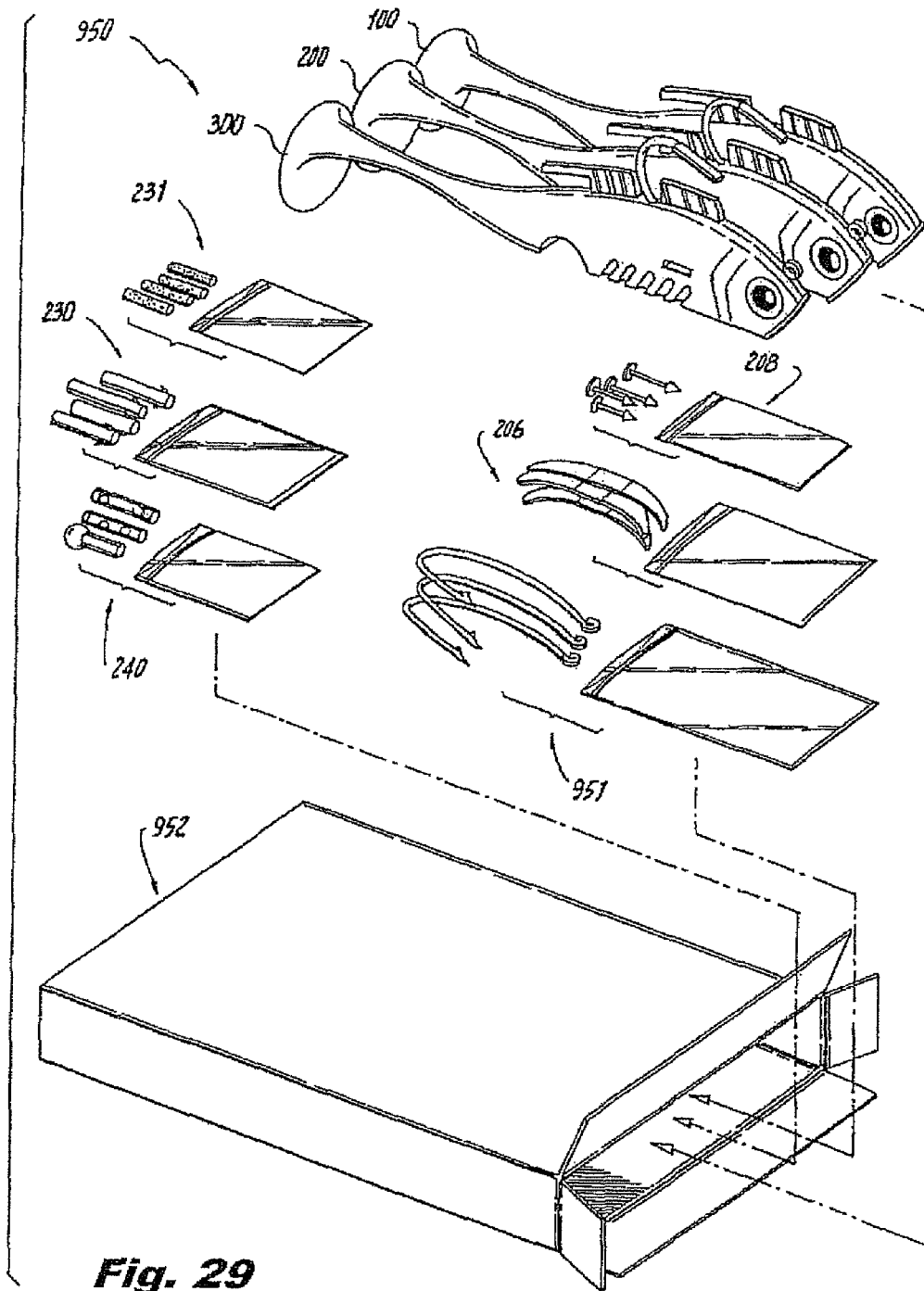
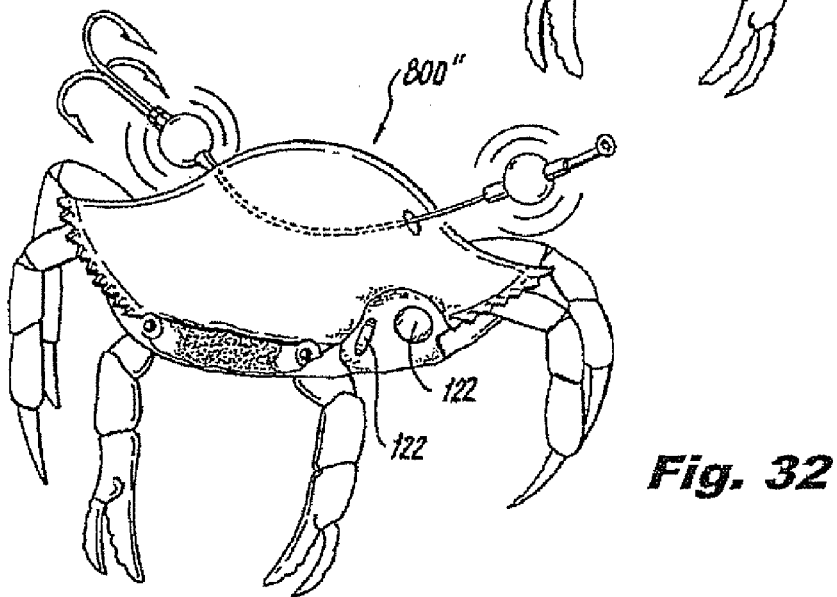
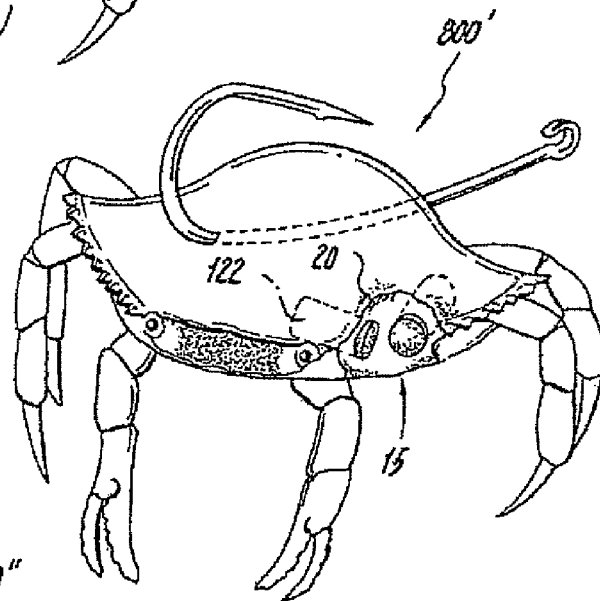

Fig. 29



Fig. 31



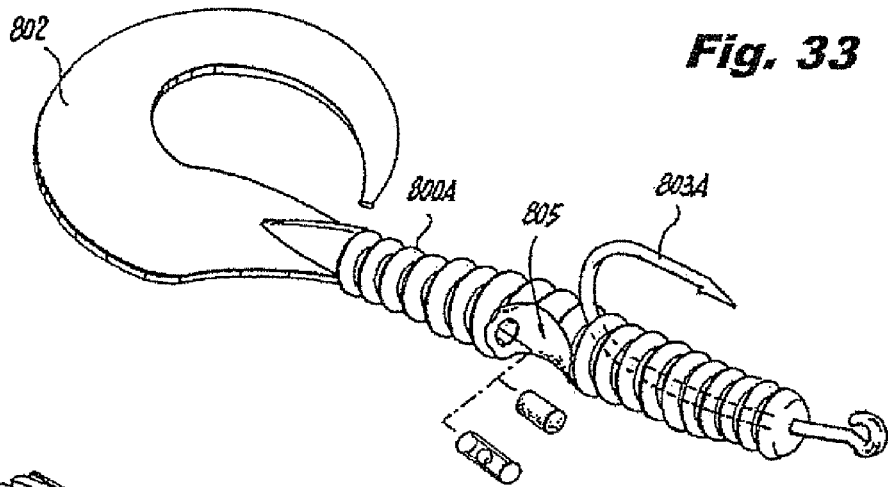

Fig. 33

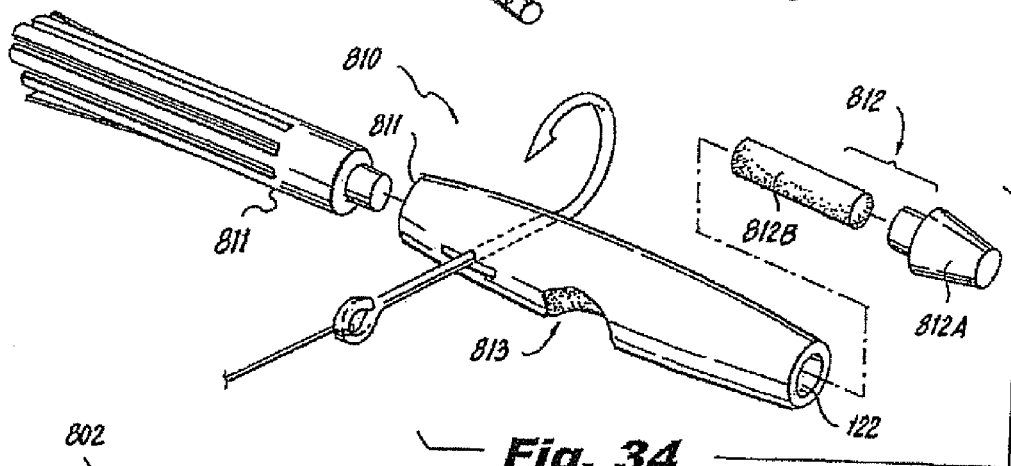

Fig. 34

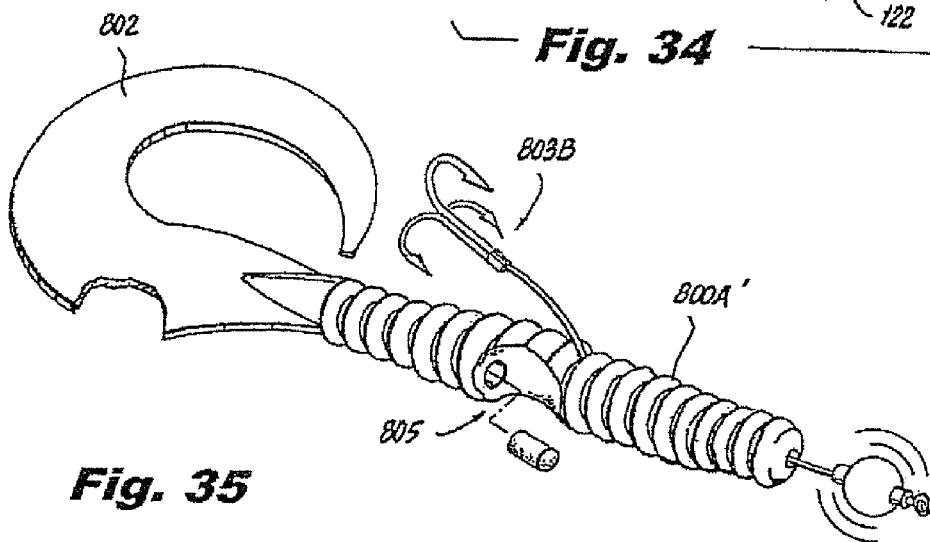

Fig. 35

FISHING LURE SYSTEM AND KIT HAVING REPLACEABLE FEATURES AND CONSTRUCTION

CROSS REFERENCE TO RELATED APPLICATIONS

This application is a continuation of and relates to and claims priority from U.S. Ser. No. 13/916,211 filed on Jun. 12, 2013, issued as U.S. Pat. No. 9,095,128 on Aug. 4, 2015, the entire contents of which are incorporated by reference which in turn claims priority from US Ser. No. 12/525,979 filed on Oct. 1, 2010, now U.S. Pat. No. 8,490,319 issued on Jul. 23, 2013, which in turn claims priority from and is a national phase of PCT/US08/61827 filed Apr. 28, 2008, U.S. Ser. No. 60/914,230 filed Apr. 26, 2007, U.S. Ser. No. 60/914,220 filed Apr. 26, 2007, and U.S. Ser. No. 60/914,223 filed Apr. 26, 2007, the contents of each of which are incorporated herein fully by reference.

BACKGROUND OF THE INVENTION

1. Field of the Invention

The present invention relates to fishing lures. More specifically, the present invention relates to a fishing lure system and kit having optional replaceable features, improved fish-attracting construction, and adaptive lure engagement means.

2. Description of the Related Art

The related art involves a plurality of fishing lures and fishing lure adaptations, each focused on particular goals as identified in respective reference. As clearly noted in the related art, each adaptation is available for its own specific purpose and not another. The focus of each adaptation is specific for the particular purpose stated.

Fishing lures have heretofore consisted of familiar, expected and obvious structural configurations to mimic healthy bait with the required physical operation of the lures by fisherman.

In U.S. Pat. No. 6,182,391 to Hubbard, the contents of which are incorporated fully by reference, a plurality of flexible lures are constructed from plastisol via injection molding or other techniques known to those of skill in the lure-manufacturing arts.

Hubbard, additionally discloses the inclusion of reflective foil, embossed foil, polyester, embossed film, metalized film, embossed metalized film, holographic foil film, and holographic metalized film, within the body or on the surface of a soft flexible lure, whereas previously such coatings or reflective materials had operated as surface coatings or films. Hubbard also discusses previously recognized lure manufacturing techniques and constructions, and limits the discussion to a preferred method for including such reflective foils or films within a lure.

Finally, the related art, in Hubbard '391 and others as noted below, discuss a plurality of alternative lure construction shapes, with differing tails, differing bodies, differing shapes, and sizes all mimicking or attempting to mimic the actions of healthy prey bait for fish. These differing shapes and sizes include representations of shapes other than fish, such as crayfish, birds, amphibians, etc. but all such shapes are incorporated herein by reference and all mimic healthy prey.

In U.S. Pat. No. 4,831,765 to Bradshaw, a simplified disclosure is provided wherein a holographic image of a fish or other living creature such as a grasshopper, or any portion of a natural environment such as grass, including (for the

fish) its eye is formed on the body of the lure. Optionally a light source is provided to illuminate a holographic image of the lure. A brief discussion of the complex multiplexing process for producing holographic images is discussed to describe how a life-like representation of a desirable healthy living animal may produced on a two-dimensional image. These discussions are also incorporated fully by reference.

Additional references are discussed below, each incorporated by reference in their entirety.

In US 2006/020176 to Yeung, a lure apparatus and system are provided where reinforced flexible segments are provided in an effort to simulate swimming in a life-like manner while being retrieved or trolled. A method of manufacturing a sports fishing lure involving a film is discussed and a number of differing lure shapes are discussed.

Also incorporated by reference are US App. No. 2006/0236588 to Rapelje, which addresses a number of alternative lure designs, and US App. No. 2006/0174535 to Beer et al., which provides a form of rattle-type fishing tackle rattle mechanism involving a rolling or rattling ball within a capsule that is fixed in the lure. The contents of each of which are incorporated herein by reference.

In US App. No. 2005/0252069 to Pool et al, an electronic flashing fishing lure is provided wherein a sensor triggers the lure's operation in an effort to trigger fish response to a health prey-bait fish.

Referring now to FIGS. 1 and 2 noted in US 2002/0189150 to Thorne, the entire contents of which are incorporated herein by reference, a castable fishing lure **1000** has a segmented body joining a plurality of rigid body members **1001** via a rigid wire pivot ring assembly **1002** to attempts to provide a simulation of a healthy life-form swimming action noted at arrows **1003A**, **1003B**. A number of hooks **1004** are affixed and a fishing line **1005** is rigidly mounted to the front rigid body member **1001A**. Due to the unpredictable nature of the hooks **1004** swinging, motion of the fishing pole pulling lure **1000**, variable tension on line **1005** and other factors the tail segment member **1001B** is caused to make an undesirable rubbing or scrapping-sound when contacting the surfaces of the head segment member **1001A** along the inner channel **1006** containing the pivot ring assembly **1002**.

Referring now to FIG. 3, noted in US 2001/0047609 to Orgeron, the entire contents of which are incorporated herein by reference, a bobber-suspended lure system **1010** includes a bobber member **1011** and a live shrimp shaped lure **1012**. A separate line **1013** is slidably connected to a hook **1014** fixed into the body of lure **1012** and includes a portion **1013A** that exits the body of lure **1012** before connecting with the hook **1014**. As discussed in Orgeron, the line portion **1013A** increases or decreases depending upon the movement **1015** of bobber **1011** floating on a wave-motion surface (not shown). In this way the hook **1014** is drawn forward bending lure **1012** to create a shrimp-backward-swimming motion to mimic the live healthy action of a fresh shrimp. An unfortunate detriment to this construction is that it requires line member **1013A** to slide into and out of lure **1012** every fraction of a second or so depending upon wave action or fishing-pole action by a user (approximately one to five movements per second), and this friction on line **1013A** causes it to fray and break rapidly, causes damage to lure **1012**, and ultimate loss of lure **1012**.

In US App. 2002/0178643 to Brodeur, a fishing lure includes a particularly selected curved shape to aid "action" during retrieval to mimic a live healthy bait-prey fish. The entire content of this reference is also incorporated by reference.

In U.S. Pat. No. 5,517,781 to Paoletta et al., a scent dispensing worm lure includes a fluid reservoir for holding scented fluid and the worm body is constructed from a resilient material such that a fish bite will compress the fluid reservoir causing the dispensing thereof.

In U.S. Pat. No. 6,807,766 to Hughes et al, it is suggested to provide a lure body having a casement for receiving an electronic insert. The insert is operated by a microcontroller programmed to implement at least one sequence of operation implemented by at least one of a LED light emitter, a vibration-producing device and an audio transducer. An electrical power supply in the insert provides power to the devices and microcontroller, and a pair of externally exposed contacts switches the microcontroller ON when bridged by water containing electrolytes, as would be found in a fishing area. Hughes also suggests that this external fluid switch also produces an electrical field around the lure, this electrical field also serving to simulate healthy living food creatures to entice fish to bite the lure. The entire contents of this reference are incorporated by reference herein.

In U.S. Pat. No. 6,922,937 to Gilbert, the entire contents of which are incorporated by reference, a fishing lure consisting of an arched hollow body with an interior bait chamber is provided. The interior chamber is divided into a buoyancy chamber and a bait chamber. A number of small openings are formed in the outer body to enable scent and bait particles to be broadcast from bait stored within the bait chamber as the lure is passed through the water. Access to the bait chamber is further provided by either a hinged cover or by a hinged connection formed in the lure body between the buoyancy chamber and the bait chamber. Once removed from the water, access to the bait chamber is readily obtained through movement of either the cover or the hinged lure body for re-supplying bait prior to supplemental use of the lure.

In U.S. Pat. No. 7,174,669 to Kailas, the entire contents of which are incorporated by reference, a lure includes an internal hollow cavity having a plurality of scent releasing apertures that produce a powerful scent trail that attracts game fish in a manner particular to the design of Kailas.

In U.S. Pat. No. 5,678,349 to Pacora, the entire contents of which are incorporated herein by reference, a clear pivoting member is pivotally attached to the upper side of a base member of a lure at its forward end so that it pivots and swings upward from the lower body base to mimic a live and healthy prey fish. When the pivoting member is swung upward, a removable insert of varying colors and appearances and of corresponding shape can be placed within the cavity of the pivoting member, and the upper body is then pivoted downward and snap-fit to the lower body base. The removable insert is thus held within the cavity of the pivoting member. A fisherman can change the color, appearance or shape of an artificial fishing lure by replacing one artificial fishing lure plug with another in an attempt to replicate a healthy and fish-attractive prey fish.

The contents of US App. 2001/0047609 to Orgeron et al, U.S. Pat. No. 7,104,004 to Renosky, U.S. Pat. No. 6,643,975 to Edwards, U.S. Pat. No. 6,301,823 to Monticello et al., US App. 20060053679 to Milanese, and U.S. Pat. No. 5,806,234 to Nichols, are also entirely incorporated herein by reference to provide additional understanding to the reader.

What is not appreciated by the related art is however, the need for a fish lure system having a replaceable fin members and a plurality of fish-attention capturing features operable as a kit in combination with a recognition that game fish are predators that recognize the traits of a wounded bait fish. Despite extensive efforts in the field no prior efforts have

focused on intentionally representing a damaged or wounded bait animal that is less than healthy.

What is also not appreciated by the related art is need for a lure kit detail allowing a hook, or a lure having a hook, to engage with a differing lure portion or popper head member to form an alternative lure assembly in a rapid manner.

What is also not appreciated is the need for such a lure-type kit construction that allows for ready adaptation and modification to fishing conditions without having to replace the lure body member itself.

What is similarly not appreciated by the related art is the need for a kit or system allowing improved use of scent, light, sound, weight motion/action, colorants, and fish-bite attractant textures that overcomes the difficulties noted above.

What is similarly not appreciated by the related art is the combination of a lure that includes a plurality of internal channels for receiving ones of scent, light, sound, and weight-motion/action modifying inserts.

Additionally, what is not appreciated by the related art is the inclusion of a weighted or rattle-sound type generating member that is positioned internal to a flexible lure allowing for secure engagement and ready shipping as a kit for a post-purchase user.

What is not appreciated by the related art is the need for a lure having a physical structure capable of giving retrieval action that resembles an action simulating wounded prey in a visible manner, for example, including fish-visible bite-wound damage that may cause non-uniform lure action during retrieval.

What is also not appreciated by the related art, is the need for a lure that may additionally include ribs or rib-like grooves along the sides of a lure that induce a lure to wobble or aid bending as the lure moves.

Accordingly, there is a need for an improved flexible lure that indicates a physical bite-wound damage site, involves a red-wound colorant proximate the damage site, and includes rib-like grooves to induce a wobble movement, ultimately rendering the lure less fluid-dynamic during retrieval.

ASPECTS AND SUMMARY OF THE INVENTION

Due to the system-type and kit-type-nature of the present system interchangeability will be recognized by one of skill in the art studying this disclosure will recognize; and such a skilled individual will also necessarily note that each and every embodiment of the present invention need not match each object or aspect of the invention discussed below. Nor will each object or aspect of the invention be reflected in every claim. As a result, the features, systems, and assemblies noted and discussed in terms of their multiple aspects must be considered flexibly and not in a rigid lock-step analysis with any particular aspect or object.

One optional and alternative goal of the present invention is to provide a flexible lure system and adaptive kit system that responds to at least one of the concerns noted above.

The lure system and kit according to the present invention departs substantially from the conventional concepts and designs and in so doing provides an apparatus developed for the purpose of imitating the sight, sound, and natural movement of a wounded bait animal that is adaptable via selectable and interchangeable features to a variety of specific wounded bait animal species having widely different prey-avoidance demands. Similarly, a user may wish to adjust the specific features of the wounded bait animal to attract a specific type or species of predator game fish. For example,

5

a wounded bait animal may be preyed upon by two species of predator game fish, one which feeds in the morning and prefers the scent of fish blood, and one which feeds in the evening and is insensitive to fish blood but is attracted to light and glitter or bubble generation. Here, a user may tailor

the features of the wounded prey animal to match the desired predator game fish.

Another optional and alternative goal of the present invention is to provide a lure that includes one or more internal open-ended or closed-ended channels for receiving optional sound, scent, light, and weight modifying inserts or may act also as chambers (without exit), or as passage ways to other exit points on a lure; including nair openings, gill openings, belly openings, tail openings, back openings, etc.

Another optional and alternative goal of the present invention is to provide a lure kit or system that enables replaceable fin features for ready assembly prior to production and modifications in the field of use, for example upon fin-loss or fin-damage.

Another optional and alternative goal of the present invention is to provide an internal sound generating device; namely a rattle-type fishing tackle sound generating device as well as any other type of sound generating device (for example a loud bubbling sound) insertable within a flexible lure, or an internal light generating device; namely a chemical light stick member positioned removably internal to the lure, and selectable by color (red, orange, green, blue etc.) to enhance wounded prey-fish lure-attraction. It is also contemplated that a light, or small-sized LED (light emitting diode), with computer enhanced programmable action imitating, sequence, intensity, color etc. may additionally be employed.

Another optional and alternative goal of the present invention is to provide an improved lure that indicates a physical bite-wound damage-type indicator, for example the use of internal glowing red-light to illuminate a wound site, the use of unbalanced or damaged fins, the use of a fin member on only one side, the use of damaged top fin members.

The present invention relates to a flexible fishing lure is provided that includes a outer shape having a transverse opening for receiving a plurality of alternatively formed lure fin members allowing a user to change the action of a lure by fin selection without replacing the lure. Multiple internal channels within the lure are adaptively provided for receiving a variety of scent sticks, sound generators, light generators, flavor generating means. Flow internal channels extend from a front opening to gill openings or fin or nair/nose allowing a water flow along an inserted scent or flavor stick member to pass through the lure body and exit proximate fin, gill, or nair locations simulating an injured or wounded prey fish. Other adaptive features enhance a lure attraction or simulate wounded features. Adaptive fins and weighting constructions allow a use to tailor a weight and action of a lure enabling a circling or injured motion during retrieval. The lure includes a flexible holographic-type attractive film and includes a physical shape having a level-maintaining physical shape and easy retrieval but with improved attractive play (increased relative flexibility). Additional rib-like side grooves induce a wobble movement and a fluid disturbance to enhance the fish-attractive features during retrieval. The present invention also proposes that the inclusion of a rattle-type sound generating member retained elastically within the lure body will improve fishing results, and lure-user fishing pleasure.

In another optional and alternative embodiment of the present invention, either flexible or rigid lure bodies may

6

include any form of decoration or attractive features that are known to those of skilled in the art or identified in the references incorporated herein by references.

According to another optional and alternative embodiment of the present invention, there is provided a flexible fishing lure system, comprising: a fishing lure body, the lure body being flexibly formed and having an outer periphery, at least one means for receiving and securing a fin in the lure body, the means for receiving including at least one fin-receiving opening, and at least one replaceable fin insertable in the one fin-receiving opening, whereby the fishing lure may be readily provided with replacement fins.

According to another optional and alternative embodiment of the present invention, there is provided a flexible fishing lure system, wherein: the fin is optionally a flexible fin and a rigid fin, and the fin includes at least one of a profile-shape selection, a color selection, and a size selection, and a raggid-bitten-shape selection, whereby the fishing lure system enables a user to readily assemble and replace the one fin to match one desired by a predator fish.

According to another optional and alternative embodiment of the present invention, there is provided a flexible fishing lure system, further comprising:

at least one means for making noise, and means within the fishing lure body for replaceably receiving the means for making noise, whereby the lure system enhances a fish attracting feature.

According to another optional and alternative embodiment of the present invention, there is provided a flexible fishing lure system, further comprising: at least one holographic attractive film within the fishing lure body, whereby an attractive ability of the fishing lure system is improved.

According to another optional and alternative embodiment of the present invention, there is provided a flexible fishing lure system, wherein: the lure body is formed from a composition containing a flexible polymer, preferably silicone. In According to another optional and alternative embodiment of the present invention, there is provided a flexible fishing lure system, wherein: the fishing lure body further includes at least one recess in the lure body as means for representing a wounding-region feature, and the at least one recess means includes at least one of a bite-mark type recess and a ribbing-type recess, whereby the at least one recess improves an attraction feature of the fishing lure system.

According to another optional and alternative embodiment of the present invention, there is provided a flexible fishing lure system, wherein: the means for representing a wound-region includes the bite mark recess with the a location of the bite-mark recess being at a selection position between a head of the lure and a tail region along a bottom belly of the fishing lure.

According to an optional and alternative embodiment of the present invention there is provided a flexible fishing lure, comprising: a preformed fishing lure fish body, the lure body being flexibly formed and having an outer periphery, means for representing a wound-region on the lure body by forming a recess inset in the lure body relative to the outer periphery, and the recess includes at least one of a bite-mark recess and a plurality of rib-type recesses along a bottom belly and side region of the lure, and a wounded flesh color reflecting light alone or in combinations in the wavelengths of red, orange, and yellow.

According to another optional and alternative embodiment of the present invention there is provided a flexible fishing lure, wherein: the recess is the bite-mark recess, and a red-color wavelength reflecting region is proximate the

bite-mark recess, whereby the red-colored region represents a red-blood color reflection of natural blood, thereby enhancing the attraction of an external game fish to the lure.

According to another optional and alternative embodiment of the present invention there is provided a flexible fishing lure, wherein: the recess is both the bite-mark recess and the plurality of rib-type recesses and an irregular shaped (teeth-marked) type recess, whereby the combination of the recess types function to cause the lure to wobble and flex during use to enhance prey attraction.

According to another optional and alternative embodiment of the present invention there is provided a flexible fishing lure, wherein: the recess is the plurality of rib-type recess along a bottom belly and the side region of the lure, and the rib-type recesses are at least one of a group comprising: dual side recesses, slanted recesses, recesses along a portion of a perimetral boundary of the outer periphery lure, and recesses in alternating patters about a common lure center line, whereby the rib-type recesses may be readily selectable by a manufacture to achieve a desired retrieval play action of the lure.

According to another embodiment of the present invention there is provided a flexible fishing lure, wherein: the lure body is formed from a composition containing silicone.

According to another embodiment of the present invention there is provided a flexible fishing lure, wherein: the means for representing a wound-region includes the bite mark recess enabling a location of the bite-mark recess at a selection position between a head of the lure and a tail region along a bottom belly of the fishing lure.

According to another optional and alternative aspect of the present invention a lure system is provided that appeals to all five (5) senses of a game fish, with interchangeable fins, weights, rattles, lights, colors, and "Scent Stick" attractants and treble hook harness and multi universal inner chamber system.

According to another optional and alternative aspect of the present invention, it is proposed that the present invention creates the first fishing lure or soft plastic bait to have interchangeable and selectable sized pectoral, anal, lateral fins, this fishing lure can be made of hard plastic, soft plastic, wood, metal, or alternate material or combination of these materials, the unique fins stiffness, thickness, viscosity, and angle construction will alter the lure performance and can be made of hard plastic, soft plastic, wood, metal or alternate material or combination of these materials, these fins connect to the lure with removable locking pin or pins to secure fin into bait, these fins can be different colors, shapes, or clear with sparkles to simulate scales, they create a unique life like visual effect employing any technology presently known to those of skill in the art or noted in the incorporated references (the context of each of which is herein incorporated again) to the lure or bait while contributing and enhancing the realism and swimming action, they also give off a unique low frequency water turbulence that is picked up by the predatory fish as a lateral line to seam more realistic and life like, these fins also will change the vertical and horizontal decent of the bait they are attached to creating a glide effect, and altering the hydro-dynamic principals of the lure or bait enabling the same lure or bait to travel in different levels of the water column for extend period of the depending on the size fin used and the lift that size fin will give the lure of bait.

It is another aspect of the present invention that a fishing lure or artificial bait may include a "Scent Stick" or fishing lure flavor stick or multiples or combinations of the same; each of which serves as an attractant that is a water soluble

hard or semi-hard/flexible stick that slowly dissolves in water based upon density and many other factors, permeating the surround areas with fish attractants, made of but not limited to fish oils, fish parts, fish scales, fish enzymes, fish fatty acids, fish amino acids, fish pheromones, fish blood, ground up worm, crayfish, shrimp, lobster, shellfish, and verity of fish species and other dies, scales, synthetic scales, having a particular dimension for insertion in the lure and having alternative physical forms to aid water flow and dissolution as will be discussed more fully below.

Another aspect of the present invention includes a "Bloody Anal Fin" display and/or a "Bloody Belly Wound" configuration, where the present bait or lure provides a unique impression that simulates a wound or previous attack bait fish damage in the lure's anal fin area that will genetically triggers fish to eat or to feed capitalizing on the easy-meal of a weak or wounded bait fish, this impression also acts an enhanced flex point, a wound and disbursement impression and a discontinuous region.

It is another aspect of the present invention to provide one or a series of chamber that run through the lure or soft plastic bait all have different functions but all work together as one unique system, they can be used individually for different functions, for a verity of uses, in a variety of locations (from head, middle, tail, top, bottom, side-side) of the lure creating a flex points, and disbursement wound feeling when being bitten by a fish that further stimulates and simulates a mark made by a larger fishing biting a smaller fish, these openings will also acts as a point of disbursement for the aforementioned scent stick scents through the scent disbursement chambers upon biting, and such biting will be further enhanced to feel softer by the reduced cross-sectional area of the lure, as well as a point of insertion for a rattle, colorant, light, or weight chamber and may also serve as a passage for an additional treble hook harness.

The above and other objects, features and advantages of the present invention will become apparent from the following description read in conduction with the accompanying drawings, in which like reference numerals designate the same elements.

BRIEF DESCRIPTION OF THE DRAWINGS

FIG. 1 is a side elevational view of a conventional fishing lure having a rigid segmented body.

FIG. 2 is a top view of the conventional fishing lure shown in FIG. 1.

FIG. 3 is a side elevational view of a conventional fishing lure for a shrimp in combination with a conventional bobber member.

FIG. 4 is a side perspective view of a fishing lure including a replaceable fin construction and a plurality of openings according to one aspect of the present invention.

FIG. 5 is a front view of FIG. 4 noting the bottom smooth surface.

FIG. 6 is a cross-sectional view along line 6-6 in FIG. 4.

FIG. 7 is a top view of a replacement fin.

FIG. 8 is a partial cross-sectional view along line 8-8 in FIG. 4 noting the hole for receiving the fin of FIG. 7 and the scent stick or rattle of FIG. 4.

FIG. 8A is a partial perspective view of an alternative bite mark showing a ragged edge as if from a toothed-bite of a prey fish.

FIG. 8B is the perspective view of FIG. 4 noting the use of an alternative fluid filled or rattle filled chamber that will fill the bite or would region and an alternative replacement anal fin member that can be similarly secured in place via

9

two receiving holes and plugs; such that either of the chamber or the fin member may additionally include a fluid containing region to dispense taste fluid upon a biting of a prey fish.

FIG. 9 is a side elevation view of an alternative embodiment of the present invention.

FIG. 10 is a partial bottom sectional view of the embodiment in FIG. 9 noting the positioning of the fin securing pin, and the use of multiple side passages to disperse attractant.

FIG. 11 is a partial perspective view of region 11 on FIG. 9 noting the alternative use of a secondary replacement side fin (similar to FIG. 4), and the additional inclusion of a bottom tail or second anal fin for the lure itself; each with a securing pin an a preferred but optional embodiment.

FIG. 12 is a partial perspective view of region 12 in FIG. 9 noting the exit of the transit body opening the top hook exit, the gap in the dorsal (top) fin, and the flexible tail extending from the dorsal (top) fin.

FIG. 13 is a partial side elevational view of an optional lure according to the present invention, wherein the lure is in a weed-free orientation as the point of the main hook is along-side of or partially in the dorsal fin allowing the dorsal fin to direct weeds and plant matter away from the hook during retrieval.

FIG. 14 is a side view of an alternative embodiment of the present invention showing a two stage removable head member and a segmented pectoral fin and a paddle tail construction with an exploded fin locking pin member.

FIG. 14A is a partial view of FIG. 14 showing the removable head member in a removed condition with a locking pin secure hole on the main body.

FIG. 14B is a partial view of FIG. 14 showing the removable head member in a removed condition with a locking pin secure hole on the head member.

FIG. 14C is a close up sectional view of the lure embodiment in FIG. 14 wherein a hook is inserted and the head member and the replaceable fin member attached by locking pins.

FIG. 14D is a partial perspective view of the region 14D in FIG. 14C wherein replacement eye members and locking stalks allow rapid replacement of lost eye features, replacement of eye colors, use of 'wounded-looking' or red eyes or different color eye-backing members.

FIGS. 15 and 15A' are partial views of the tail of FIG. 14, wherein a split tail is presented and optional positioning openings are presented in multiple aspects of the tail region.

FIGS. 15A, 15B, 15C, and 15D are side views of alternative insertable weight members having retaining structures which allow optional use of various weights without departing from the scope of the present invention.

FIGS. 16A through 16F are prospective side views of alternative insertable scent stick constructions that may include scent sticks, bubble or oxygen generating sticks, blood sticks, light generating sticks, glitter containing sticks, or other attractants and multiple combinations of the same, and optionally dissolvable construction stick members having a variety of shapes.

FIGS. 17A through 17C represent alternatively constructed fin locking pins for securing fin members (FIGS. 18D-18G) to a lure body constructed from any material including plastics, metals, rubbers, silicone, polymers, wood, and combinations thereof.

FIGS. 18A through 18H represent top and associated side or sectional views along noted sectional lines of replaceable fin constructions.

FIG. 18I is a front view of a lure of the present system including a weighted fin and optionally a weighted retaining

10

pin according to FIG. 18F, wherein such assembly causes asymmetric buoyancy of the lure and results in a rotation around rotation point R during retrieval and an associated yaw-rotation Y about the vertical center of the lure.

FIGS. 19A through 19D are side views of alternatively shaped sound generating and partially or fully insertable rattle members including alternative protrusion designs.

FIG. 19E is a combination of a sound generating device and a scent, color, taste, or other attractant stick within a holding member allowing joint combination within a lure body in the same insertion path as an optional variation of lure attractant.

FIG. 20 is an alternative construction of FIG. 14C noting the inclusion of an alternative hook feature via multiple optional internal body channels, allowing adaptive hook positioning.

FIGS. 21, 21A, and 21B show an adaptive key lock member for a universal lure attachment system, shown here with a preferred popper-head construction, wherein an attachment head receives a hook member and a key lock member to secure the same to a lure lead member, noting a hook-shank locking pin system for engaging a hook with a lure attachment. It should also be recognized that the hook may be firmly fixed to the head and simply driven/pushed into the lure body.

FIG. 22A is a side view noting a mouth or front entry flow channel connecting with gill exit channels of a lure construction.

FIG. 22B is a partial top cross sectional view along line 22B-22B in FIG. 22A noting the inter-connection from a central channel allowing flow of scent or other taste attractant members from gill openings of a lure from a scent region.

FIG. 23A is a side view noting a mouth or front entry flow channel connecting with gill exit channels only of a lure construction.

FIG. 23B is a partial top cross sectional view along line 23B-23B in FIG. 23A noting alternatively shaped inner flow channels to enhance water and volume flow.

FIG. 24 is an exploded side view of a super-popper head member version adaptable to engage an existing lure.

FIG. 25A is a front perspective view of an alternative cylindrical super-popper head construction configures to secure cylindrical lures.

FIG. 25B is a front perspective assembly view of an alternative super-popper head construction configured to enhance lure action and including a plurality of inner channels for use in a manner discussed herein (including scents, weights, color or light generators, etc.) with an optional secure locking pin to secure the same to the lure.

FIG. 26 is a side perspective view of an assembly as noted in FIG. 24 or 25B of the super-popper head and a lure body. It is noted that the hook engagement aids securing the popper head but this is not required and that the lure-line attachment remains on the lure itself and need not be transferred to the popper head as in FIGS. 21, 21A, and 21B.

FIG. 27 is an alternative embodiment of the present invention wherein a hookless lure having the features discussed herein may be equipped with a side-mounted hook projected through the lure body or via pre-formed lure body openings at an angle that is non-parallel with the long axis-direction of the lure, allowing non-standard rotation and pivot action of the lure during retrieval.

FIG. 28, is an alternative embodiment of the present invention similar to FIG. 27 wherein the look placement or position is perpendicular to the long axis-direction of the lure.

11

FIG. 29 is an exploded perspective view of a kit assembly according to one embodiment of the present invention, wherein a plurality of hooked and un-pre-hooked lures are provided in combination with spare hooks, weights, locking pins, attractant sticks, replacement fins, and other elements as noted herein.

FIG. 30 is an alternative lure construction (non-fish) shown as a crab including each of the features noted in earlier discussions. In FIG. 30, insertion openings, replaceable legs (in place of replacement fins), a bite mark and other items are noted.

FIG. 31 is an alternative perspective view of the lure noted in FIG. 30 with a through hook, a bite-mark portion noting a wounded-quality and containing receiving openings for weights, attractants, bladders (as noted in FIG. 8B), etc. As similarly noted in FIG. 8A a ragged bite mark may be employed.

FIG. 32 additionally is similar to FIG. 31 wherein a through passage in the body of the lure is provided (as in FIG. 20) for passage of a hooked line.

FIG. 33 represents an adaptive alternative of the present invention, wherein a silicon lure is presented as a shrimp, a worm, a leach or other generally lengthy member and includes a bite mark region noting a wound and an inserting member in combination with a hook.

FIG. 34 is an exploded view of an alternative of the present invention, wherein a silicon lure is presented as a shrimp, worm, or leach (shown here), including a wounded region, replacement front tip with included scent stick or weight or other attractant member, and a transverse positioned hook.

FIG. 35 is a flexible attractant view of the lure as in FIG. 33 but with a through-positioned treble hook member.

FIG. 36 is an alternative flexible lure according to the present invention, wherein a frog-shaped member includes a wounded region also including a receiving opening for receiving a scent or other attractive item.

FIG. 37 is an alternative flexible lure, as in FIG. 36, wherein a replaceable member (the frog leg) is similar to the replacement fin member in FIG. 4 and may be replaced from a plurality of differently weighted, shaped, colored, and wounded type limb members.

DETAILED DESCRIPTION OF THE PREFERRED EMBODIMENTS

Reference will now be made in detail to several embodiments of the invention that are illustrated in the accompanying drawings. Wherever possible, same or similar reference numerals are used in the drawings and the description to refer to the same or like parts or steps. The drawings are in simplified form and are not to precise scale. For purposes of convenience and clarity only, directional terms, such as top, bottom, up, down, over, above, and below may be used with respect to the drawings. These and similar directional terms should not be construed to limit the scope of the invention in any manner. The words "connect," "couple," and similar terms with their inflectional morphemes do not necessarily denote direct and immediate connections, but also include connections through mediate elements or devices.

Referring generally now to FIGS. 4 through 8, a silicon based, elastomeric or plastisol type-fishing lure is provided at 100 in a similar plastic-forming technique as that noted in the earlier references incorporated herein again by reference. A series of recesses 15 along sides a body member 10 such that the bait lure is additionally rendered flexible and

12

vides a life-like action to rod-motion during retrieval. Similarly, recesses 15 help to simulate "wounded prey" and will enhance game-fish strikes on the lure via lure/water interaction during retrieval.

Body member 10 includes a head region 1, a tail region 2, and a central region 3 between the two. Eye members 4 are provided along with gill colorants in head region 1 or gill-molded regions 6 to simulate the gills and colorations of a live bait fish.

During normal operation, an eye ring 8 is fixed to a fishing line (not shown), and lure 100 is drawn through water via retrieval in a manner simulating bait-fish action.

During such retrieval tail region 2 flexes vertically as shown at A, A and also flexes horizontally as shown at B-B to simulate a fish-tail in a combined motion.

One or more recesses 15 are provided as shown and include one or more fully optional bite-mark recess 16 that pass from one side of the lure body 3 to the other, and a plurality of rib-type recesses 17 arrayed along a side portion of the lure body. In the side view noted in FIG. 4, the perimetral edge (the outer shape) is continuous when viewed, but as noted particularly in the cross-section in FIG. 6, recesses 17, extend inwardly to main body member 10, while the tail region 2 is visible in the rear.

During retrieval, water washes over recesses 17 causing lure 100 to additionally wobble, generate disturbances in the water, and otherwise bring instability in an attempt to attract fish. Recesses 17 may be in the form noted and positioned on the lower side periphery portions of lure 100. For example, recesses 17 may slant forward, rearward, vertically, and may be of deeper or shallower construction. As shown best in FIG. 4, the preferred recesses 17 are shallow channels formed during or after the molding process. It is envisioned that these recesses 17 may assist the user in tricking game fish into believing the lure 100 is "slashed" or exhibits a "bitten" and "injured" effect simulating "wounded prey" and hence an instinctive desire to bite.

Noting particularly FIG. 5, a bottom surface 101 and a sloped leading edge 102 enable lure 100 to pass through water and remain on a continual plane due to the long and reasonably flat bottom surface 101. Thus, the present invention proposes the ability to glide through the water without immediately diving or rising from an initially set depth allowing a user to "play" the bait in a convenient manner without undue effort to maintain a consistent use-depth.

As noted in the related art, it is additionally envisioned, that lure 100 may include internal holographic film 104 or other visual attractants formed internally so that as lure 100 flexes during fishing-use or strike, film 104 is readily observable to provide an improved attractant feature. Similarly, and without limitation to the present preferred embodiment, film 104, or any other type of surface colorant or formed feature (for example scales 105 in FIG. 1) may be employed on the surface of lure body 10 so as to glitter, and attract fish in a manner known to those of skill in the art.

It is additionally envisioned, that recess 16 as a bite mark may optionally included a wound-colored region 20, for example in the color red and related visual color wavelengths recognized by game fish such that the color selected represents blood or injury from the "now-wounded" lure body 10.

It is therefore proposed that the present invention simulates "wounded prey" unlike any other. It is also proposed that those of skill in the art will recognize the one or more "bite-mark" recess 16 because of the colorant (red) and because they think it represents a wound that will make the baitfish easier to catch. The "bite-mark" feature as discussed

13

gives lure **100** an irregular wobble action that attracts fish, due to the removal of silicone material, weakening the integrity of the lure body **100** causing tail region **2** to flex and appear “weak” or “wounded”. This weakness makes the lure swim or translate through the water during retrieval in an unpredictable and asymmetric way, simulating the weak or injured baitfish that predator species key-in on or are attracted to.

Additionally, the bite-mark recess features gives the lure an enhanced side-to-side wobble along lines A-A, B-B that additionally exposes any internal holographic or attractant foil and the holographic eyes **4** to more direct light than other lures. This feature allows lure **100** to seemingly change colors when it is retrieved through the water and gives off an easily visible, nature-type fish and glow that predator species are attracted to. Additionally, the red color signals to predator species is a signal of a wounded, injured, or vulnerable bait fish.

It will be recognized that recesses also work in tandem (the bite mark and the wounded rib-type features) to give the lure the life-like action of a sick or wounded fish. Here, rib-type recesses are formed by removal or non-molding of silicon or plastisol type material causing the lure to wobble and bend more as it swims. It is proposed that the overall shape of lure **100** works together to lure the game fish with a unique, unpredictable, and injured action not found in other fishing lures.

The present preferred embodiments include a number of additional attractant features. As noted in FIG. **4** through the end, one or more fin members **110** is provided and includes opposing fin-texture sides **111**, **111**, spaced by a generally central region **112**. Fin member **110** fits and engages with lure **100** via fin-locating opening **115**. Fin member **110** may be made from any suitable material to enable sufficient bending and flexing for installation within fin-locating opening **115** (FIG. **4**), for example silicone.

While those of skill in the lure forming arts, as incorporated herein by reference again, and further to those incorporated references, fin member **110** may be formed in any suitably flexible, durable, and adaptive manner, for example the use of Silicon or plastisol in a gel form.

Central region **112** allows users to readily insert a leading edge (an end) of fin **110**, ultimately pulling fin **110** through lure **100** so that the two elements (body and fin) are in condition for use as a completed lure **100** (FIG. **6**). Fin **110** may be formed or molded by those of skill in the art to include veining or fin-texture (as shown in FIG. **7**), but there is no requirement that this combination be filed of any specific type.

As will be additionally noted by those of skill in the art, foil member **104** is considered to be “above” the normal plane of the fin-installation and so is not noted in FIG. **6**, the cross-sectional view.

An additional feature combines lure body **100** with proposed rattle or noise making system **120** containing a bounding outer member **121**, and at least one rattle member **121A** and be shaped for insertion into a preformed opening **122**, shown here as a circular passage, within lure **100**. Noise making system **120** may be formed as shown and simply make noise by shifting during lure retrieval.

As will be recognized by those of skill in the art having studied the present disclosure, passage **122** may be any shape or geometry sufficient to receive and retain noise making system **120** (shown circular, may be rectilinear, triangular, ovoid, etc.). As an additional benefit of the present system, lure member **100** may be provided in a combinable kit form (See FIG. **29**) with a number of

14

differing noise making systems **120** that may be combined in a variety of ways without departing from the scope and spirit of the present invention.

While lure **100** is shown in the particular format preferred, nothing herein shall restrict lure **100** to this particular form or shape. Thus, for example, tail region **2** may be generally circular, forked, spiral, etc. all without departing from the scope and spirit of the present invention.

Referring now to FIGS. **8A** and **8B**, it will be noted that alternative embodiments are presented. In FIG. **8A** a raw or ripped-out wound feature is presented at **15'** wherein a number prey-teeth marks **15'A** are shown molded on either side of the lure proximate indication region **20** having a wound color. Additionally a number of pseudo-ripped flesh tabs **15'13** project and extend into bite region **15'** to simulate the resultant injury from a ripping prey-fish action. In this way (FIG. **8A**) the wounded-feature or wounded-indication system at **15** (et al.) may be adapted to various scenarios and to enhance the ‘hunger/interest/instinct-impact’ prey-fish have to strike the lure **100**.

As will be noted in FIG. **8B**, additionally region **15**, **16** may be filled with replaceable feature members **16A**, **16B** having respective spud ear members **16A'** projecting from either side to frictionally engage openings **122**, **122** to retain feature members **16A**, **16B** in place. As shown, feature member **16A** is a hollow region **16D** bounding a volume containing a number of rattling ball members **16E** that click together during retrieval to generate noise. Additionally, shown is an access portal **16F**, allowing replacement of ball members **16E** or the insertion of a fluid or powdered scent attractant (e.g., fish paste, blood, glitter etc.), so that upon a strike a game fish may remove member **16A** and upon biting receive a scent disbursement into their mouth to increase their hunger; the action lure will also render lure **100** to appear to be wounded with the loss of “flesh” in the form of feature member **16A**.

Feature member **16B** is shown as a flexible fin member but may also be hollow having a stress concentration region **16W** such as a narrowing or a thinning in the wall of the fin so that any scent attractant stored therein will be dispersed upon the strike when the force applied preferably renders open the region **16W**. Similarly, feature member **16B** will generate a similar wounded-flesh feeling in a striking game fish by delivering the scent and also by allowing them to feel a ‘particle’ of ‘flesh’ in their mouths enticing them to return to strike lure **100** fully. In this way, each of these feature members **16A**, **16B** may be employed to fill wound-feature **16** in a way that also enhances the attraction of the lure **100**.

Referring now to FIGS. **9** through **12** an adaptive flexible lure construction includes a plurality of inner chamber members **201** extending from a lure entry location **202** into an interior of lure **200**, or in the case of chamber **201B** may pass completely through the lure body. In other cases, additional side chambers **201A** may extend from an inner chamber **201** to an exterior of lure **200**, as will be explained. As will be noted in the Applicant’s related applications, lure entry location **202** may be formed as a ‘bite mark’ as noted in FIGS. **4**, **9**, but it will also be recognized that such bite marks may be positioned anywhere along the body of lure **200** without departing from the present spirit and scope of the invention thereby allowing an improved “wounded bait” appearance. For example, a bite mark may be near a top side or near a tail at **202'** (FIG. **9**).

Additionally, as noted also in FIG. **12**, at least one fin member **203** is removably positioned and replaceably positioned along a top spinal axial direction of lure **200** and includes a front portion **203A**, and a rear portion **203B**,

15

having a detached flexible flag portion **203W** that may be adaptively curved during manufacture to flutter during retrieval of lure **200** or may be loosely constructed, so that the appearance of a moving fin is given during retrieval of lure **200**. For removably and replaceably positioning fin member **203** or fin portions **203A**, **203B**, it is envisioned that a channel insertion receives a portion of front and rear fin member **203** portions as shown and retains them until removed by a fish-striking action, allowing for their ready replacement or color selection upon a user choice or to be partially removed as an additional wounded-simulation feature.

A lateral or middle fin opening **205** extends transversely through lure body **200** from one side to the other and replaceably receives a fin member **206** (see examples at FIGS. **18D-18H**), as shown that may be of multiple constructions as will be discussed. Extending from a bottom side of lure **200** is a channel **207** for receiving a locking pin member **208** (not shown see examples at FIGS. **17A** through **17C**) and for extending through an engaging hole **209** in fin member **206** to secure the same, as will be discussed.

As will be appreciated, the present construction allows an angler to actually customize the lure in situ (in process during fishing) in a plurality of ways without departing from the initial lure body, or between lure bodies. Such interchangeability allows immediate adaptation to fishing conditions, fish preferences, and other fish attracting details.

Referring now to FIGS. **9** and **11**, an alternative position for replacement or insertable lateral fin member **206'** or dorsal (bottom) fin member **206''** is noted with associated through or insertion holes or openings **205'**, **205''**, and associated locking pin members **208'**, **208''**. In this way, one may reposition and remove fins along the length of lure member **200** to customize the lure as desired.

As noted additionally dorsal (bottom) fin member **206''** may be provided in a hollow liquid-filled configuration (as shown) so that when bitten or opened, disperses the liquid filling and where the filling is a blood scent or other prey attractant provided an additional scent attractant to the system.

While lure **200** is shown with a paddle tail member **210**, alternative tail constructions, for example a split tail construction **211** is noted in FIG. **15A'**. As such, tail member **210** may operate in any manner based upon the construction material for lure **200**, and any predetermined inner cavity impacts. Tail member **210** may operate vertically along arcs V, V, horizontally along arcs H, H or any combination thereof.

Additionally referring now to FIG. **20**, a top hook feature **212** projects from top fin member **203** and, as will be noted more greatly in detail in future figures (FIG. **20**), an adaptive treble or other hook members **225**, **225'**, and **225''** having an attachment lead member **226** and a fixing loop member or link **227** will fix lead member **226** to hook **212** by simply sliding over the same (in a loop or a link) and may employ channels **201**, **201A**, **201B** as passage ways for the inclusion of alternative hook members. Since hook **212** and hook **225** are physically linked together by link **227**, a bite on either hook will capture the fish, and allow hooking-force to transmit along hook **212** to a user's rod a great benefit is provided as well as the flexibility to position hooks as desired within the same lure. Another great benefit is that hooks **225**, **225'**, and **225''** may be installed and removed by attaching to hook **212** without the need to re-tie and reconnect to the main lure-line allowing a speedy change with great security attached to main hook **212**. This provides a unique advantage not found in the related arts.

16

Similarly, while hook **225** is positioned below lure **200**, it will be readily recognized, that by adjusting a length of attachment lead member **226** (a cable, chain, strand, filament, etc.) a variety of other internal channels **201** may be employed without departing from the scope and spirit of the present invention. For example a tail extending hook **225'**, a dual back extending hook **225''**, or other location may be employed by simply feeding lead member **226** through a selected channel **201** to ultimately engage secured hook member **212** allowing force transfer. It is imagined that this tactic will be of particular use with game fish that attack from behind, as the major portion of hook **225'** may be concealed within the lure body tail portion until hit by the fish.

As noted, in the figures (FIG. **9**), one or more eyes **227** are provided. Additionally, the present discussion contemplates, and herein incorporates by reference all previously known attractive features and methods noted in the references that have been incorporated by reference herein, for example foils, sparkles, colors, etc.

Referring now to FIG. **14D** an eye system **227'** includes one or more replacement eye members **227A**, each provided with a securing rod member **227B** having one or more friction enhancing features **227C** such as barbs, a rough surface, diameter changes etc, similar to those pins **208** to secure the fins. Additionally, a colored iris **227D** may be additionally used in combination so that eye members **227** may be adaptively and removably secured in receiving holes **227E** in the head member portion of any lure member. In this way, one of skill in the art having studied the complete disclosure will recognize that eye members **227A**, or iris members **227D** may be differently colored or with different reflective qualities and maybe varied on either side of the lure. Additionally, one of the eyes may be used with a red-color, or may be removed from the lure to indicate a wounded feature (eye loss). Of course, the present invention also recognizes that if eye-loss occurs at an undesirable time, a replacement eye may be easily inserted in the lure.

Referring now to FIG. **13**, an alternative lure construction **200'** is shaped with a weed dispersing or weed-splitting feature with a stiffened or lengthened front fin portion **203A'** allowing hook member **212'** to be positioned in contact on a side of fin **203A'** or to be imbedded lightly in fin **203A'** (as shown) so that upon a fish strike the bite will free the tip of hook member **212'** from the location near or in fin **203A** to catch the fish. In this way during retrieval water flow (and weed flow) is along direction W which directs any plant or other matter off the hook to to disperse the weeds away from hook **212'**. In this manner, this weed-slitting feature may be employed with any of the other embodiments discussed herein to provide an additional optional feature.

Referring now to FIGS. **14**, and **14A** through **14D**, an alternative lure construction shape **300** includes top split fins **203** and a plurality of channels **201**, **201A**, and **201B**, both in the body, head, and tail, and notes the inclusion of hook **212**. In this embodiment an alternative construction includes a head member portion **310** form from a substantially rigid material such as wood, metal, or plastic, and a flexible body member portion **311** formed from a substantially flexible material such as silicone or plastisol as is known to those of skill in the art. A joining wedge member **313** extends from optionally head member portion or body member portion and includes a hole **312A** in the body portion and a through hole **312B** in the wedge member **313** for receiving a fixing pin member **312** with friction fit teeth members similar to the weight system or pins for fixing in FIGS. **17A-17C**. In operation, a use may readily employ rigid head member **310**

17

with a variety of replaceable flexible body member portions **311** in an interchangeable manner so that upon destruction or non-use damage to flexible portion **311** it may be quickly replaced.

Additionally, as shown in FIG. **14C**, where a hook member **212** extends from rigid head member **310** it may be readily inserted into the flexible body member portion **311**, as shown in FIG. **14C**, to enhance lure construction flexibility.

Referring now specifically now to FIGS. **15A-15D**, internal channels **201**, **201A**, **201B**, in any location (body, tail, fin etc.) may receive optimally formed weights **230A-230D** of a weight system formed from any conventional material and being either rigid, or flexible, or both. Insertion retention means **231**, in the form of projecting ribs, hooks, or spikes project from outer surfaces of weight members **230A-230C** to enable a secure insertion of the same within channels **201** and engagement within the walls thereof for a friction fit preventing unintended removal. It is particularly useful to rapidly change and vary the weights for lures **200**, **300**, as is discussed in the parent applications to this application, noted earlier and again incorporated fully by reference, so as to allow the lures **200**, **300** to sink uniformly, non-uniformly, spin, or sag as desired to attract fish, and the present product may be sold as a kit, having a plurality of replacement weights and other features without departing from the scope of the present disclosure.

It will be additionally recognized, that weights **230A-230D** in the weight system may additionally be formed as fin members **206** (See FIGS. **18DA-18H**) and insertable into respective body fin holes **205**, **205'**, **205''**, **115**, and any other fin hole receiving location, to additionally weight a lure to enhance an attractive action, for example a balanced location of a weighted front fin may be further enhanced by the insertion of a weighted stick in a tail section of the lure, as was disclosed in FIGS. **15**, **15A**.

Additionally, weights **230A-230D** in the proposed weight system are not restricted to the shapes shown, but may be of any shape capable of use with the lure system proposed. These weight shapes include, but are not limited to barrel shapes, round shapes, spherical shapes, split shapes, fin-type shapes, or lastly the shape of the fin-fixing pins **208**, **208'** etc. may also be formed from a heavy material like metal to act as a weight.

Referring now to FIGS. **16A** through **16F** a plurality of so-called scent sticks **231** in a scent stick system are providing in differing physical forms and having differing physical make-ups. It is envisioned that any adapted scent stick may be removably inserted in inner channels **201**, **201A**, **201B**, etc., and may be combined with any other type of weight, or scent stick, or color generating member, as will be discussed.

As noted, scent sticks may include a blood scent, a flavor scent, may generate bubbles or oxygen via chemical reaction with surrounding water, and may generally be selected from any type of fish-attractant material that is pressed, squeezed, dried, evaporated, cut, extruded, or otherwise formed by known forming methods into a suitable shape. Similarly, scent sticks may be constructed from a number of solid and liquid compounds and even binders which when combined enable creation of a dried stick-like shape. For example, a scent stick may contain by weigh approximately 0-10% oil, 0-50% fish powder, 0-30% starch, and 0-25% shrimp, 0-40% dried fish blood in various combination with other taste or smell elements or in combinations with other visual elements such as glitter (cut flakes or small particles of reflective or brightly colored material) or bubble generating

18

element (pressed NA_2OH_3 , or other substance that reacts with water and generates visible bubbles), all in sum amounting to 100 weight % for each stick.

In a specific (but non-limiting) example, a scent stick may contain 5% fish oil, 30% fish powder, 25% shrimp, 35% dried fish blood, 2.5% organic binder and 1.5% glitter and 1% bubble generator. This type of scent stick will be substantially rigid when formed after drying but will absorb water/moisture during continuous use and will slowly dissolve over a period of time when exposed to water/moisture. The rate of dissolution will depend upon the pressure used informing or extruding the scent stick, the chemical makeup of the water (by salt content, by pH, by temperature, the volume of scent stick exposed to the water, and by free elemental percentage (e.g., % of non H_2O in the water). It will be recognized by those of skill in the art having read and understood the present disclosure that these weights and percentages may be varied without departing from the scope and spirit of the present invention to provide a variety of selectable products.

As noted, in FIG. **16B**, scent sticks **231** may optionally include channel gripping members projecting as **232**, may be formed in a shape not the same as the inner geometry of inner channels **201**, such as a triangular shape **233**, rectangular shape **234**, or may have flow channels **235** along an outer surface so as to allow water to penetrate inner channels **201**, **201A**, **201B**, etc. and to flow along the surface of scent sticks **231**, and react with the same to aid fish attraction when the water carries the dispersed scent from the lure into the prey fish's scent or taste senses (during trolling, retrieval, or during an actual prey fish strike).

Similarly scent sticks may be formed with stress-concentration features to create preferred fracture points (for example, periodic inward detents or grooves **235'** (FIG. **16D**, others not shown) along the outer surface of a scent stick or radial grooves about the outer diameter of the stick) so that when bitten by a game fish, a non-dissolved solid portion of the scent stick will preferably break off at the stress concentrator **235'** and optimally exit the lure and enter the mouth of the game fish and be considered as a torn-off flesh-portion of a real wounded bait-fish to enhance the desire of the prey fish to consume the bait lure.

As will be additionally noted, scent sticks may be in fact a series of scent pellets or smaller shapes capable of insertion within channels **201** (all). Similarly such pellets or scent sticks may be constructed from combinations of types of scents (blood, flavor, bubble generating, etc.). Thus, in combination it is possible for an angler to customize the "scent load" within a given channel **201**, selecting for example a combo stick, or small pellets in series of (blood, blood, bubbles, flavor), as the combination will readily be inserted into a channel **201** depending upon the location and length of a particular channel **201**.

As will be additionally noted in FIGS. **19A** through **19D**, a series of sound generating members **240A-240D** maybe formed for removable insertion along channels **201**, and may include balls **241** that shift internally to make a rattling or clicking sound, in a manner discussed in the incorporated references. Similarly, it is envisioned that sound generating members **240** may also include protuberance members **242**, **243** that may be additionally colored or may be illuminated by chemical light means to project from channels **201**, or may be employed to fill "bite-marks" within a lure body as noted in FIG. **8B**, for example. As also shown, herein sound generator **240** includes adaptive bulge member **243** to fill the anal opening in the lure to improve fluid flow and aid sound generation when in use. In this way it is envisioned that a

19

user may selectively include a plurality of sound generators, light generators, and scent generators within the same lure in a manner customized for a particular prey fish.

It should be additionally noted that sound generating weights and their containers may be constructed from any suitable material or combinations of materials so as to vary the sound generated (for example glass beads make a different sound than lead balls). Thus, it is envisioned that a plurality of suitable materials may be employed including glass, Plexiglas, plastic, metals, stones, etc. all without departing from the scope and spirit of the present invention.

It is additionally included, but not pictured, that chemical color generators (so called light-sticks, or other small sight-type sticks noted in the sports industry) may be similarly inserted into inner channels **201** to attract game fish during evening or other times of day, and that these would appear in a similar stick configuration as in FIG. **19A**

Additionally included, but not pictured, are the inclusion of sound emitting diodes or other sound emitting electronic devices (small-sized) in the form of small sticks or units insertable into channels or openings in the lure body to aid game fish attraction.

Referring now to FIG. **19E** it will be appreciated that a hollow tube member **240'** may receive a sound generator **240A** in combination with a scent stick **231** to provide a combined sound and scent or light attractant system that sharply departs from the related art and allows the use of lures **100**, **200**, and **300** (or any of the other bait shapes noted herein) under a wide variety of lighting and fishing conditions.

As noted in FIGS. **17A** through **17C** a number of locking pins **208**, **208A-208C** are provided with a number of friction enhancing features **208D** to secure respective fin members to the body of lures **100**, **200**, and **300**, or otherwise secure a replacement fin or lure appendage (e.g., head members **310** in FIGS. **14**, **14A**, and **14B**) upon a press fit into the respective receiving through hole.

Referring now specifically to FIGS. **18A** through **18H** a plurality of alternative fin-type constructions are provided. As noted in the present discussion, respective fins **206** may include surface textures **111** (FIG. **7**) or as shown texture **250** such as veins, or gaps, may include a non-uniform or injured-appearing shape **251** having a shredded appearance. Similarly, fins **206** may be formed in any color, shape, and may include internal scent chemistry bound into the polymer as is known within the art (this is noted as decaying with time, a detriment immediately cured by the present invention. Colors may vary by side of the fins. A weight receiving channel **201F** noted in FIG. **18H**, similarly to channels **201** above, may be shaped to receive any form of insertable attractant discussed herein. Where a weight **230** is inserted in channel **201F** (which may be a transverse or parallel orientation with a plane of the fin member **206**), a single side fin member may sag (noted in FIG. **18IH**) causing lure **200** to circle downwardly upon cast, appear wounded, and otherwise attract game fish.

Similarly, a plurality of positioning holes **209** for receiving fixing pins or locking pins **208**, may be provided allowing a user to position fins **206** off-center or off-balance to a lure body also increasing lure play and serving as an attractant.

Referring now to FIGS. **21**, **21A**, and **21B**, an alternative system for a hook lure lock system includes a head member **415** having an inner receiving cavity **410** and an external attachment point **416** for joining with fishing line or other structure. An external slot **411** is provided for receiving a locking pin member **410** in a flush-manner as will be noted

20

from the construction design. A removable hook member **420** having an eye socket is provided conventionally, or custom made to fit within socket **410** and based on the orientation of the eye socket is prevented from rotating relative thereto.

Alternative locking engagement members **410** may be shaped to fit within flush opening **411**. Alternatively an extending pin member (not shown) inserts along inner opening **410A** so it engages with pin **410** and engages head member **415** with the hook **420** within inner opening **410A** to affix both the locking pin **410**, and the hook member **420** to head member **415**. Because it is optionally intended for an extending pin member **403** to pass through the eye opening in hook member **420** and lock to head member **415**, a secure force transfer path is created from eye member **416** back to the end of the hook.

In this manner, it is suggested that a suitably constructed head member may be readily joined to any number of conventionally shaped hook members or even suitably or custom made hook members.

Referring now to FIGS. **22A**, **22B**, **23A**, and **23B**, alternative lure systems **500**, **500'** are provided formed in manners discussed herein and incorporated by reference. A series of inner channels or openings **201B** are now positioned at the lure head to receive water flow from the retrieval action and urge it along an interior passage way or even an internal chamber **201A'**. As will be noted, additional side passages **201B''** may connect main channel **201B'** to locations **201AB** proximate the gills of a lure, or optionally via channels **201A''** to a series of "nair" openings to the front of the lure. It is envisioned that one or a series of scent sticks (shown) may be inserted into front channel **201B** and that water flow will pass over this stick and flow out the nair openings and gill openings to more readily simulate a bait fish. Additionally, upon receiving a strike-force, such strike force will force additional fluid flow along channels **201B** (anywhere in the lure) and push out a "pulse" of scented water to further fix and secure the game fish to the bite fish.

Referring now to FIGS. **24A** through **26**, an alternative construction is suggested in lure system **600** including a lure body **402** and a "supper popper" type head member **700** that is removably joined to lure body **402** via compression or other suitable means including use of a locking pin **208**, **208D**. Lure body **402** includes an eye **602** for securing a hook but this is not required.

Head members **700**, **700'**, and **700''** are constructed from elastic and buoyant EVA foam or other suitable material and has an inner shape and diameter to fit over the outer shape and diameter of a lure in a snug way securing an elastic fit, and potentially being physically restrained by eye member **602**.

Head members **700**, **700'**, **700''** may be simply a cylinder as noted in FIG. **25A**, or may be formed on an inner and outer surface to enhance action, as noted as head member **700'** in FIG. **25B**, or may be formed in any other way to enhance fishing action—for example, head member **700**, **700'**, **700''** may be formed as a slider for skimming lure (skimming surface **600** proximate bottom of **700''** in FIG. **26**) along a surface of the water, or may be formed in any other surface or sub-surface action modifying shape without departing from the spirit and scope of the present invention.

In FIG. **26**, a bottom plane surface and triangular head of head member **700''** improve retrieval action, eye members **702** may readily replace/cover the lure's existing eyes **601**, providing a larger "eye" target for attack. Similarly, head member **700**, **700'**, and **700''** may include a plurality of inner channels **201**, or a plurality of stopped channels (called

21

chambers) for receiving a plurality of attractant or control items (weights, sounds, lights, colors, scents, etc.) as taught in the present disclosure.

Additionally, while heads **700**, **700'**, **700"** may be formed of any material, including: wood, metal, plastic, elastomeric materials, and rigid materials; each material employed may require a different method for securing it to the underlying lure. For example, a locking pin **208**, **208D**, as earlier discussed may be insertable in a hole on a bottom surface of head member **700'** and be pushed into the lure body to fix head member **700"** in place. Additionally, as used herein, locking pin **208D** may be formed from lead, or any other metal for weight or strength enhancement. It is envisioned, that due to the extreme size of head member **701**, that a plurality of openings, chambers, locking pins etc., may be need to control the action of the lure during retrieval. Also head members **700**, **700'**, **700"** may be colored or decorated in any manner known to the art and as identified in the references incorporated herein.

It is additionally envisioned, that the location of head members **700** et. seq. may need to accommodate hook eye member **602** to provide a uniform front surface to the retrieval action, whereby a restricted or concave portion **800** along a front surface of head member **700"** is removed and receives eye **602** of the hook to allow head member **700** et. seq. to slide into position.

Referring now to FIGS. **27** and **28** an alternative embodiment of the present invention is provided at lures **400'** and **400"** wherein a lure body as earlier discussed with all of the features earlier discussed receives an external hook member **212'** or **212"** that is fed through the body of the respective lure in a direction that is off-angle or not in line with the long direction of the lure body such that drawing the lure line in direction D', or D" causes respective lures **400'**, **400"** to pivot widely along directions P at the head and tail members to additionally simulate a wounded and non-naturally swimming bait fish as an additional attractant.

Referring now collectively to FIGS. **30** through **37** the earlier discussed features are adapted to a number of alternative lure forms without departing from the scope and spirit of the present invention.

Referring specifically to FIGS. **30** to **32** a crab embodiment **800**, **800'**, or **800"** is employed with a removable and replaceable leg member **801** employing a fixing pin **208** as earlier discussed. Similarly a bitten region **15** or **20** are provided where part of the crab embodiment is removed to simulate a wounded bait crab and provide a visually appealing lure to a prey fish. As also noted body openings **122** may receive lighted members, scent sticks or weighted members in the manners discussed above.

Referring now to FIGS. **33** and **35** a worm or shrimp type flexible embodiment **800A**, **800A'** provides a flexible curled tail **802** and a hook member **803A**, **80313** that is either fixed in the body or fed through a body opening as shown in FIG. **35**. What is additionally noted is a bite section **805** removed from the lure to simulated a wounded region and similar receiving channels **122** and sound, light, or scent generators as earlier discussed.

The details in FIGS. **33** and **35** are similarly noted in FIG. **34** where a representation of a tiny shrimp or a leach **810** is provided with a body region **811**, a flexible tail member **811** or a replacement head member **812** wherein a bite feature **813** is provided as is a through opening **122** for receiving a scent member **812B**.

Additionally, in FIGS. **36** and **37** a frog lure member **900** is provided with a bite or wound feature **913** and an opening channel **913'** for receiving a scent stick or other attractant

22

914. Additionally noted is a removable and replaceable leg member **901** joinable with a pin member **208**, as shown.

In this manner it will be appreciated that the features discussed above may be readily adapted to a variety of alternative lure shapes without departing from the scope and spirit of the present invention.

Referring now to FIG. **29** a kit assembly is provide as embodiment **950** containing a variety of lure bodies **100**, **200**, **300**, a variety of hook members separately packaged **951**, a variety of locking pin members **208**, a plurality of scent stick members **231**, a plurality of weights **230**, a plurality of sound attractant systems **240**, and a plurality of fin members **206** all packaged in a box member **952** for ready transport and storage. As will be appreciated by one of skill in the art having studied the attendant kit and assembly **950** the interchangeable features provided may be employed to appeal to any of the five senses of the prey fish (sight, sound, feel, taste, and smell) to provide a five-senses lure to a user.

As will be appreciated by those of skill in the art having studied the included disclosure that the lure body while preferably flexible, may easily include each of the features in a substantially rigid or rigid body with adaptations to accommodate the same. As noted one embodiment included a rigid head member, and where a rigid body member were included the weights, scent sticks, colors, and other items insertable in the passages would still operate on a friction fit function but would now engage the rigid sides of the passages with the spike members or rubber fingers or by mere friction itself so as to ensure a similar operation.

As used in the claims the outer surface of the lure, the periphery shape is the premetral or outer shape not bound to any particular specific shape (fish, crab, shrimp, frog, leach, worm, etc.) and refers broadly to the existence of the shape but not a particular shape.

Similarly, it will be appreciated that a bite mark or recess type **16** that passes from side to side of a lure may be applied to a non-fish shape (for example the crab and other non-fish-shape lures in the text, but also spoon type baits (rigid bent sheets of curved solid material) known to be of a type to those of skill in the art. As a result, it will be appreciated that each of the above features may be applied to a variety of lures within the scope and spirit of the present invention.

It will be also appreciated that while embodiment **100** did not include a hook, the same may be provided in a kit or an assembly provided to the public with the other features as discussed herein without departing from the scope and spirit of the present invention.

Additionally, in regard to a kit or an assembly package, nothing herein shall so limit the kit or assembly embodiment to those features shown. It will be understood that additional items may be included in the kit without departing from the scope and spirit of the present invention, for example, additional fishing line, other lures, mechanical or electronic noise or sound generating systems.

It will be additionally appreciated by those of skill in the art that the phases system or assembly may be used interchangeably based on the context without departing from the scope of the present invention and without limiting the particular claim or discussion. For example, a sound generating system or a sound generating assembly will be recognized as including at least one of the sound creating (audible vibration creating (in air or water)) items noted herein. Similarly, the fact that fish will both scent and taste the compounds and in the 'scent' sticks is to be interpreted as limiting. It will be understood that some compounds may be 'smelled' and some may be 'tasted' by a fish and some may

be both 'smelled' and 'tasted' without departing from the scope of the present discussion.

As will additionally be understood by those of skill in the art, the phrase 'flexible' or 'adaptive' when used to describe the lure system itself will be understood similarly to mean a lure system wherein a number of functions and options maybe inter-used or optionally employed according to the desire of a user. For example a flexible lure system includes many options as would an adaptive lure system.

Whereas the phrase 'flexible' when used to discuss the body of a lure itself refers to a characteristic of the body—namely being flexible or bendable itself. As a consequence, those of skill in the art will appreciate that a flexible lure system may have either a rigid lure body, a flexible lure body or a jointly assembled flexible and rigid body (as in FIGS. 14-14B) without departing from the scope and spirit of the present invention.

It will additionally be understood by those of skill in the art that the use of the phrase fin member in the claims will be broadly interpreted to include shapes that represent fins on a fish-type lure, but may also include replacement limbs or to other members of a non-fish type lure (for example a replacement claw-leg in a crab-type lure or a replacement leg in a frog-type lure).

It will also be understood by those of skill in the art that the phrases bite mark or bite shape will be adequately represented by the phrases semi-cylindrical or semi-cylindrical without departing from the scope and spirit of the present invention.

In the claims, means- or step-plus-function clauses are intended to cover the structures described or suggested herein as performing the recited function and not only structural equivalents but also equivalent structures. Thus, for example, although a nail, a screw, and a bolt may not be structural equivalents in that a nail relies on friction between a wooden part and a cylindrical surface, a screw's helical surface positively engages the wooden part, and a bolt's head and nut compress opposite sides of a wooden part, in the environment of fastening wooden parts, a nail, a screw, and a bolt may be readily understood by those skilled in the art as equivalent structures.

Having described at least one of the preferred embodiments of the present invention with reference to the accompanying drawings, it is to be understood that the invention is not limited to those precise embodiments, and that various changes, modifications, and adaptations may be effected therein by one skilled in the art without departing from the scope or spirit of the invention as defined in the appended claims.

What is claimed is:

1. An adaptable fishing lure system, comprising:
 - a fishing lure body;
 - said lure body having an outer periphery surface;
 - at least one means for replaceably receiving and securing a fin member in said lure body and for projecting said fin from said outer periphery surface;
 - said means for replaceably receiving further comprising:
 - at least one fin-receiving opening bounded by a portion of said lure body;
 - at least one replaceable fin member insertable in said one fin-receiving opening, whereby said fishing lure may be readily provided with replacement fins; and,
 - said means for replaceably receiving further comprises:
 - at least one fin locking member to secure said fin member in said lure body;
 - said fin locking member extends through a portion of said fin member and lure body; and

at least one means for scent dispersal during a use of said lure system,

wherein the fin member includes at least one of a fin and a leg.

2. The adaptable fishing lure system of claim 1, wherein fin member further includes at least one of a claw-leg and a frog-leg.

3. An adaptable fishing lure system, comprising:

- a fishing lure body having an outer periphery surface;
- at least one means for replaceably receiving and securing a fin member in said lure body;

- said means for replaceably receiving further comprising:
 - at least one fin-receiving opening bounded by a portion of said lure body,

- at least one replaceable fin member insertable in said one fin-receiving opening;

- at least one fin locking member to secure said fin member in said lure;

- said fin locking member extending between a portion of said fin member and said lure body;

- whereby said fishing lure may be readily provided with replacement fins; and

- said fishing lure body is one of a flexible lure body, a rigid lure body, a combination lure body containing both a flexible body portion and a rigid body portion; and an assembly combination lure body wherein flexible body portions and rigid body portions may be removably affixed to each other during a use thereof,

- wherein the fin member includes at least one of a fin and a leg.

4. The adaptable fishing lure system of claim 3, wherein the fin member further includes at least one of a claw-leg and a frog-leg.

5. A fishing lure kit, comprising in combination:

- a package for removeably bounding a plurality of fishing lure assembly members comprising:

- a plurality of fishing lure bodies each having an outer periphery surface;

- at least one means for replaceably receiving and securing a fin member in each said lure body;

- said means for replaceably receiving further comprising:

- at least one fin-receiving opening bounded by a portion of said lure body, at least one replaceable fin member insertable in said one fin-receiving opening, and at least one fin locking member to secure said fin member in said lure body;

- said fin locking member extending through a portion of said fin member and lure body; whereby said fishing lure may be readily provided with replacement fins;

- at least one means for adapting an attraction-feature of said lure system, selected from the group of attraction-features consisting of:

- means for making a sound vibration of said lure system during a use of said lure system;

- means for making a visible light emitted by said lure system during said use of said lure system;

- means for dispersing one of a scent and a taste of said lure system during said use; and

- means for modifying a weight of said lure system during said use;

- said means for replaceably receiving and securing said one of said means for adapting in each said lure body, and said means for replaceably receiving and securing including at least one passage region defined in each said lure body,

- wherein the fin member includes at least one of a fin and a leg.

6. The adaptable fishing lure system of claim 1, wherein the fin member further includes at least one of a claw-leg and a frog-leg.

* * * * *