

(12) **United States Patent**
Nickel et al.

(10) **Patent No.:** **US 9,918,865 B2**
(45) **Date of Patent:** **Mar. 20, 2018**

(54) **BRACES USING LACING SYSTEMS**

USPC 602/5, 23–29, 62, 65, 20–21; 24/712,
24/712.4, 713, 19, 68 R, 68 SK, 71 SK;
128/882; 36/50.1, 117.7; 2/22
See application file for complete search history.

(75) Inventors: **Michael J. Nickel**, Golden, CO (US);
Sean T. Cavanagh, Golden, CO (US);
Robert E. Burns, Denver, CO (US);
Mark Kerns, Golden, CO (US);
Edward L. Weaver, II, Milford, OH
(US); **Sherry A. Hinds**, Goshen, OH
(US); **Beth E. Gramza**, Cincinnati, OH
(US)

(56) **References Cited**

U.S. PATENT DOCUMENTS

59,332 A	10/1866	White et al.
80,834 A	8/1868	Prussia
117,530 A	8/1871	Foote
228,946 A	6/1880	Schulz
230,759 A	8/1880	Drummond

(Continued)

FOREIGN PATENT DOCUMENTS

AT	127075	2/1932
AT	244804	1/1966

(Continued)

OTHER PUBLICATIONS

U.S. Appl. No. 09/956,601, filed Sep. 18, 2001, including its
prosecution history, Gary R. Hammerslag.
(Continued)

Primary Examiner — Ophelia A Hawthorne
(74) *Attorney, Agent, or Firm* — Kevin W. Weber; Sandra
K. Nowak

(57) **ABSTRACT**

The disclosure relates to medical braces having lacing systems for tightening of the medical braces. Some embodiments include multiple components of the lacing system integrated into a single housing piece. For example, multiple reels can be used to tighten different portions of the lacing system, and the multiple reels can be mounted onto a single housing. Also, multiple lace guides can be integrated into, or attached to, a single housing piece.

21 Claims, 14 Drawing Sheets

(73) Assignee: **3M Innovative Properties Company**,
St. Paul, MN (US)

(*) Notice: Subject to any disclaimer, the term of this
patent is extended or adjusted under 35
U.S.C. 154(b) by 1005 days.

(21) Appl. No.: **13/174,533**

(22) Filed: **Jun. 30, 2011**

(65) **Prior Publication Data**

US 2012/0004587 A1 Jan. 5, 2012

Related U.S. Application Data

(60) Provisional application No. 61/360,619, filed on Jul.
1, 2010.

(51) **Int. Cl.**
A61F 5/02 (2006.01)
A61F 5/01 (2006.01)
A43C 1/00 (2006.01)
A43C 11/16 (2006.01)

(52) **U.S. Cl.**
CPC **A61F 5/028** (2013.01); **A43C 1/003**
(2013.01); **A43C 11/165** (2013.01); **A61F 5/01**
(2013.01); **A61F 5/0118** (2013.01); **A61F**
5/0123 (2013.01)

(58) **Field of Classification Search**
CPC A61F 5/028; A61F 5/01; A61F 5/0118;
A61F 5/0123; A43C 1/003; A43C 11/165

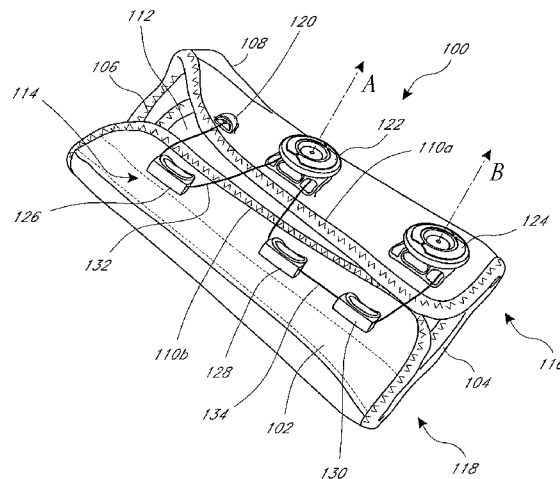

(56)

References Cited

U.S. PATENT DOCUMENTS

746,563	A	12/1903	McMahon	4,741,115	A	5/1988	Pozzobon
819,993	A	5/1906	Haws et al.	4,748,726	A	6/1988	Schoch
908,704	A	1/1909	Sprinkle	4,760,653	A	8/1988	Baggio
1,060,422	A	4/1913	Bowdish	4,780,969	A	11/1988	White, Jr.
1,062,511	A	5/1913	Short	4,787,124	A	11/1988	Pozzobon et al.
1,083,775	A	1/1914	Thomas	4,790,081	A	12/1988	Benoit et al.
1,090,438	A	3/1914	Worth et al.	4,796,829	A	1/1989	Pozzobon et al.
1,170,472	A	2/1916	Barber	4,799,297	A	1/1989	Baggio et al.
1,288,859	A	12/1918	Feller et al.	4,802,291	A	2/1989	Sartor
1,393,188	A	10/1921	Whiteman	4,811,503	A	3/1989	Iwama
1,469,661	A	2/1922	Migita	4,826,098	A	5/1989	Pozzobon et al.
1,412,486	A	4/1922	Paine	4,841,649	A	6/1989	Baggio et al.
1,416,203	A	5/1922	Hobson	4,856,207	A	8/1989	Datson
1,481,903	A	4/1923	Hart	4,870,723	A	10/1989	Pozzobon et al.
1,530,713	A	2/1924	Clark	4,870,761	A	10/1989	Tracy
1,502,919	A	7/1924	Scib	4,884,760	A	12/1989	Baggio et al.
1,862,047	A	6/1932	Boulet et al.	4,937,953	A	7/1990	Walkhoff
1,995,243	A	6/1934	Clarke	4,961,544	A	10/1990	Biodia
2,088,851	A	8/1937	Gantenbein	5,001,817	A	3/1991	De Bortoli et al.
2,109,751	A	3/1938	Matthias et al.	5,016,327	A	5/1991	Klausner
2,124,310	A	9/1938	Murr, Jr.	5,042,177	A	8/1991	Schoch
2,316,102	A	4/1943	Preston	5,062,225	A	11/1991	Gorza
2,539,026	A	1/1951	Mangold	5,065,480	A	11/1991	De Bortoli
2,611,940	A	9/1952	Cairns	5,065,481	A	11/1991	Walkhoff
2,673,381	A	3/1954	Dueker	5,117,567	A	6/1992	Berger
2,907,086	A	10/1959	Ord	5,152,038	A	10/1992	Schoch
2,991,523	A	7/1961	Del Conte	5,157,813	A	10/1992	Carroll
3,035,319	A	5/1962	Wolff	5,158,428	A	10/1992	Gessner et al.
3,112,545	A	12/1963	Williams	5,177,882	A	1/1993	Berger
3,163,900	A	1/1965	Martin	5,181,331	A	1/1993	Berger
3,169,325	A	2/1965	Fesl	5,184,378	A	2/1993	Batra
3,197,155	A	7/1965	Chow	D333,552	S	3/1993	Berger et al.
3,221,384	A	12/1965	Aufenacker	5,249,377	A	10/1993	Walkhoff
3,276,090	A	10/1966	Nigon	5,259,094	A	11/1993	Zepeda
3,401,437	A	9/1968	Christpohersen	5,315,741	A	5/1994	Debberke
3,430,303	A	3/1969	Perrin et al.	5,319,868	A	6/1994	Hallenbeck
3,491,465	A	1/1970	Martin	5,325,613	A	7/1994	Sussmann
3,545,106	A	12/1970	Martin	5,327,662	A	7/1994	Hallenbeck
3,618,232	A	11/1971	Shnuriwsky	5,335,401	A	8/1994	Hanson
3,668,791	A	6/1972	Salzman et al.	5,341,583	A	8/1994	Hallenbeck
3,678,539	A	7/1972	Graup	5,345,697	A	9/1994	Quellais
3,703,775	A	11/1972	Gatti	5,355,596	A	10/1994	Sussmann
3,729,779	A	5/1973	Porth	5,357,654	A	10/1994	Hsing-Chi
3,738,027	A	6/1973	Schoch	5,381,609	A	1/1995	Hieblinger
3,793,749	A	2/1974	Gertsch et al.	5,425,161	A	6/1995	Schoch
3,808,644	A	5/1974	Schoch	5,425,185	A	6/1995	Gansler
3,934,346	A	1/1976	Sasaki et al.	5,430,960	A	7/1995	Richardson
3,975,838	A	8/1976	Martin	5,433,648	A	7/1995	Frydman
4,130,949	A	12/1978	Seidel	5,463,822	A	11/1995	Miller
4,142,307	A	3/1979	Martin	5,477,593	A	12/1995	Leick
4,227,322	A	10/1980	Annovi	5,502,902	A	4/1996	Sussmann
4,261,081	A	4/1981	Lott	5,511,325	A	4/1996	Hieblinger
4,267,622	A	5/1981	Burnett-Johnston	5,535,531	A	7/1996	Karabed et al.
4,408,403	A	10/1983	Martin	5,537,763	A	7/1996	Donnadieu et al.
4,433,456	A	2/1984	Baggio	5,557,864	A	9/1996	Marks
4,463,761	A	8/1984	Pols et al.	5,566,474	A	10/1996	Leick et al.
4,480,395	A	11/1984	Schoch	5,596,820	A	1/1997	Edauw et al.
4,507,878	A	4/1985	Semouha	5,599,000	A	2/1997	Bennett
4,551,932	A	11/1985	Schoch	5,599,288	A	2/1997	Shirley et al.
4,555,830	A	12/1985	Petrini et al.	5,600,874	A	2/1997	Jungkind
4,574,500	A	3/1986	Aldinio et al.	5,606,778	A	3/1997	Jungkind
4,616,524	A	10/1986	Biodia	D379,113	S	5/1997	McDonald et al.
4,619,057	A	10/1986	Sartor et al.	5,638,588	A	6/1997	Jungkind
4,620,378	A	11/1986	Sartor	5,640,785	A	6/1997	Egelja
4,631,839	A	12/1986	Bonetti et al.	5,647,104	A	7/1997	James
4,631,840	A	12/1986	Gamm	5,651,198	A	7/1997	Sussmann
4,633,599	A	1/1987	Morell et al.	5,658,241	A	8/1997	Deharde et al. 602/5
4,654,985	A	4/1987	Chalmers	5,669,116	A	9/1997	Jungkind
4,660,300	A	4/1987	Morell et al.	5,718,021	A	2/1998	Tatum
4,660,302	A	4/1987	Arieh et al.	5,718,065	A	2/1998	Locker
4,680,878	A	7/1987	Pozzobon et al.	5,732,483	A	3/1998	Cagliari
4,719,670	A	1/1988	Kurt	5,736,696	A	4/1998	Del Rosso
4,719,709	A	1/1988	Vaccari	5,737,854	A	4/1998	Sussmann
4,719,710	A	1/1988	Pozzobon	5,755,044	A	5/1998	Veylupek
4,722,477	A	2/1988	Floyd	5,761,777	A	6/1998	Leick
				5,784,809	A	7/1998	McDonald
				5,819,378	A	10/1998	Doyle
				5,934,599	A	8/1999	Hammerslag
				5,956,823	A	9/1999	Borel

(56)

References Cited

FOREIGN PATENT DOCUMENTS

U.S. PATENT DOCUMENTS			CA		
6,038,791	A	3/2000 Cornelius et al.	CA	2112789	8/1994
6,070,886	A	6/2000 Cornelius et al.	CA	2114387	8/1994
6,070,887	A	6/2000 Cornelius et al.	CH	41765	11/1908
6,052,921	A	8/2000 Oreck	CH	111341	11/1925
6,102,412	A	8/2000 Staffaroni	CH	199766	9/1938
D430,724	S	9/2000 Matis et al.	CH	204834	5/1939
6,119,318	A	9/2000 Maurer	DE	555211	7/1932
6,128,836	A	10/2000 Thierry	DE	641976	2/1937
6,148,489	A	11/2000 Dickie et al.	DE	1661668	8/1953
6,202,953	B1	3/2001 Hammerslag	DE	7043154	3/1971
6,213,968	B1	4/2001 Heinz et al.	DE	7045778	3/1971
6,240,657	B1	6/2001 Weber et al.	DE	1785220	5/1971
6,256,798	B1	7/2001 Egolf et al.	DE	2062795	6/1972
6,267,390	B1	7/2001 Maravetz et al.	DE	7047038	1/1974
6,289,558	B1	9/2001 Hammerslag	DE	2341658	3/1974
6,416,074	B1	7/2002 Maravetz et al.	DE	2414439	10/1975
6,467,195	B2	10/2002 Pierre et al.	DE	2900077	7/1980
6,477,793	B1	11/2002 Pruitt et al.	DE	2914280	10/1980
6,543,159	B1	4/2003 Carpenter et al.	DE	31 01 952 A1	9/1982
6,568,103	B2	5/2003 Durocher	DE	8101488	7/1984
6,708,376	B1	3/2004 Landry	DE	38 13 470 A1	11/1989
6,711,787	B2	3/2004 Jungkind et al.	DE	3822113 C2	1/1990
6,735,829	B2	5/2004 Hsu	DE	43 02 401 A1	8/1994
6,757,991	B2	7/2004 Sussmann	DE	9413147	10/1994
6,775,928	B2	8/2004 Grande et al.	DE	93 15 776.2	2/1995
6,802,439	B2	10/2004 Azam et al.	DE	9315776	2/1995
6,877,256	B2	4/2005 Martin et al.	DE	29503552	4/1995
6,922,917	B2	8/2005 Kerns et al.	DE	19624553	1/1998
6,945,543	B2	9/2005 De Bortoli et al.	DE	19945045 A1	9/1999
6,976,972	B2	12/2005 Bradshaw	DE	20116755	1/2002
6,993,859	B2	2/2006 Martin et al.	EP	0 589 232 A1	3/1994
D521,226	S	5/2006 Douglas et al.	EP	0 589 233 A1	3/1994
7,076,843	B2	7/2006 Sakabayashi	EP	0 614 624	9/1994
7,082,701	B2	8/2006 Dalgaard et al.	EP	0 614 625 A1	9/1994
7,134,224	B2	11/2006 Elkington et al.	EP	0 651 954 A1	5/1995
7,281,341	B2	10/2007 Reagan et al.	EP	0 693 260 B1	1/1996
7,293,373	B2	11/2007 Reagan et al.	EP	0 734 662 A1	10/1996
7,331,126	B2	2/2008 Johnson	EP	1 236 412 A	9/2002
7,367,522	B2	5/2008 Chen	FR	1349832	1/1964
7,442,177	B1	10/2008 Garelick	FR	1374110	10/1964
7,584,528	B2	9/2009 Hu	FR	1404799	7/1965
7,591,050	B2	9/2009 Hammerslag	FR	2019991	7/1970
7,597,675	B2	10/2009 Ingimundarson et al.	FR	2108428	5/1972
7,617,573	B2	11/2009 Chen	FR	2173451	10/1973
7,694,354	B2	4/2010 Philpott et al.	FR	2175684	10/1973
7,908,769	B2	3/2011 Pellegrini	FR	2 399 811	3/1979
7,950,112	B2	5/2011 Hammerslag et al.	FR	2 565 795 A1	12/1985
7,954,204	B2	6/2011 Hammerslag et al.	FR	2 598 292 A1	11/1987
7,992,261	B2	8/2011 Hammerslag et al.	FR	2 770 379 A1	5/1999
8,056,150	B2	11/2011 Stokes et al.	FR	2 814 919 A1	4/2002
2002/0068890	A1	6/2002 Schwenn et al.	GB	11673	6/1899
2002/0095750	A1	7/2002 Hammerslag	GB	216400	5/1924
2002/0178548	A1	12/2002 Freed	GB	2 449 722 A	5/2007
2003/0177662	A1	9/2003 Elkington et al.	JP	33-9202	9/1955
2005/0054960	A1	3/2005 Telles et al.	JP	49-028618	3/1974
2005/0081403	A1	4/2005 Mathieu	JP	51-131978	11/1975
2005/0098673	A1	5/2005 Huang	JP	51-002776	1/1976
2005/0198866	A1	9/2005 Wiper et al.	JP	51-121375	10/1976
2006/0156517	A1	7/2006 Hammerslag	JP	53-124987	3/1977
2007/0169378	A1	7/2007 Soderberg	JP	54-108125	1/1978
2008/0016717	A1	1/2008 Ruban	JP	62-057346	4/1987
2008/0060167	A1	3/2008 Hammerslag	JP	63-080736	5/1988
2008/0060168	A1	3/2008 Hammerslag	JP	03-031760	3/1991
2008/0066272	A1*	3/2008 Hammerslag et al. 24/712	JP	3030988	3/1991
2008/0249448	A1	10/2008 Stevenson	JP	7-208	1/1995
2009/0184189	A1	7/2009 Soderberg	JP	10-199366	7/1998
2010/0139057	A1	6/2010 Soderberg	JP	1004-016732	1/2004
2010/0299959	A1	12/2010 Hammerslag	JP	2004-041666	2/2004
2011/0167543	A1	7/2011 Kovacevich et al.	WO	WO 94-09728	5/1994
2011/0225843	A1	9/2011 Kerns et al.	WO	WO 1995/03720	2/1995
2011/0266384	A1	11/2011 Goodman et al.	WO	WO 1998/37782	9/1998
			WO	WO 1999/15043 A1	4/1999
			WO	2000-53045	9/2000
			WO	WO 2000/76337 A1	12/2000
			WO	WO 2001/08525 A1	2/2001

(56)

References Cited

FOREIGN PATENT DOCUMENTS

WO WO 01/60289 8/2001
WO WO 2007/016983 A1 2/2007

OTHER PUBLICATIONS

Re-Examination of U.S. Pat. No. 7,591,050, Re-Exam Control No. 90/011,028, including its prosecution history, filed Jun. 11, 2010, Gary R. Hammerslag.

U.S. Appl. No. 13/174,527, dated Jun. 30, 2011, Jesse D. Cotterman, et al.

U.S. Appl. No. 13/273,060, dated Oct. 13, 2011, Soderberg, et al. ASOLO® Boot Brochure Catalog.

* cited by examiner

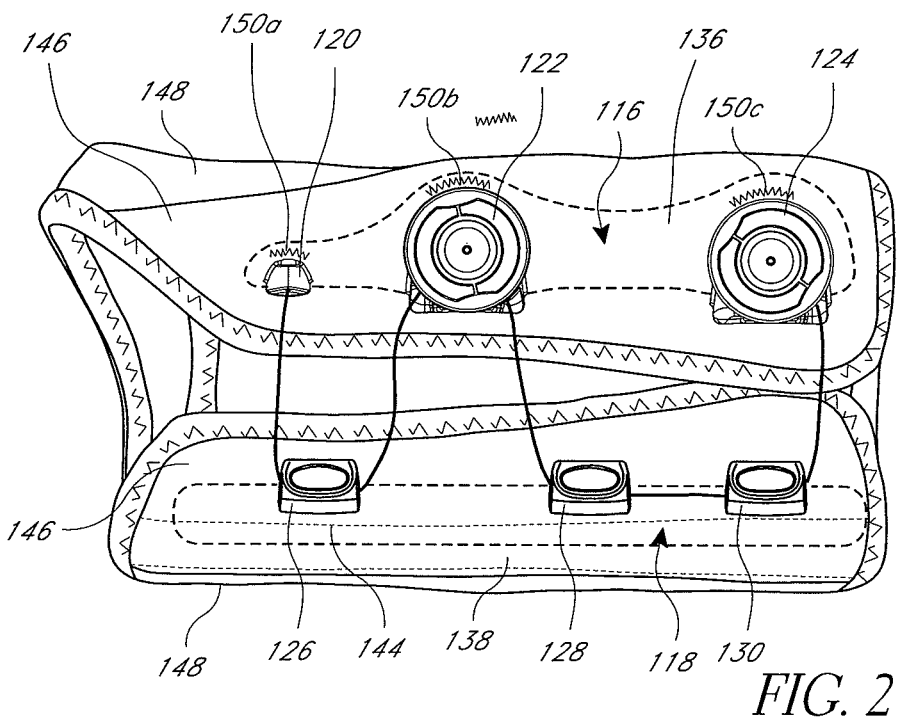
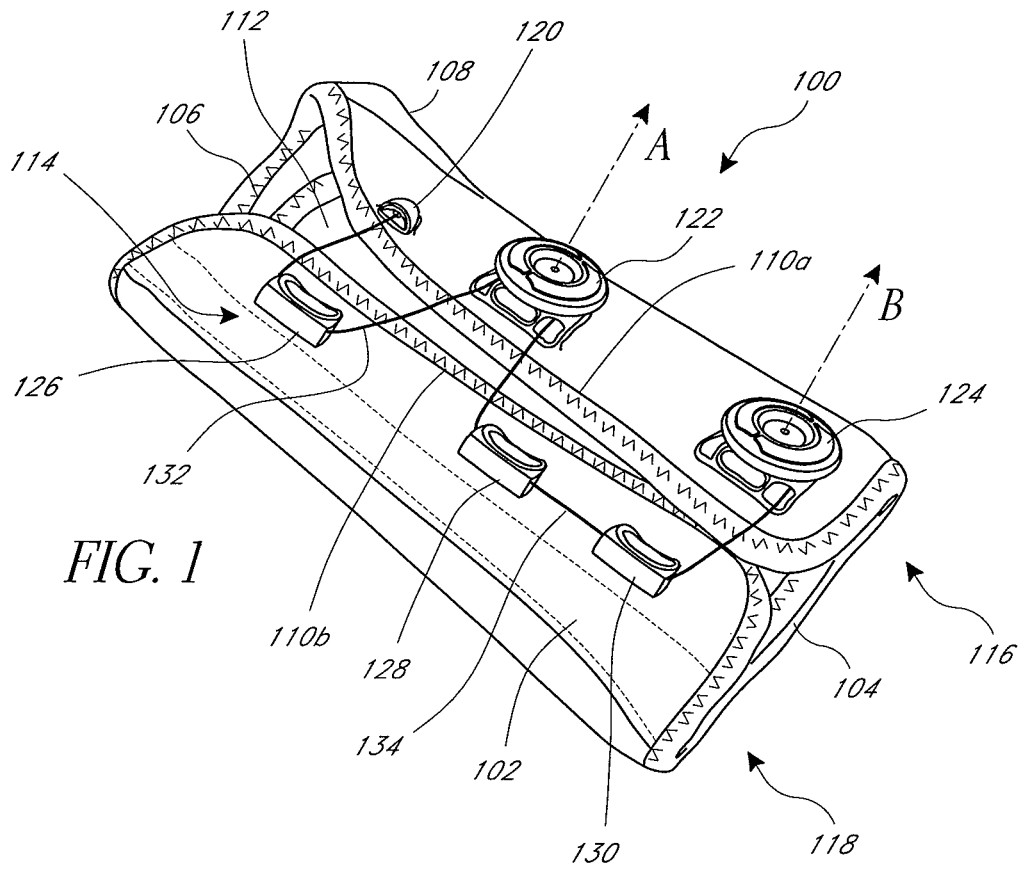

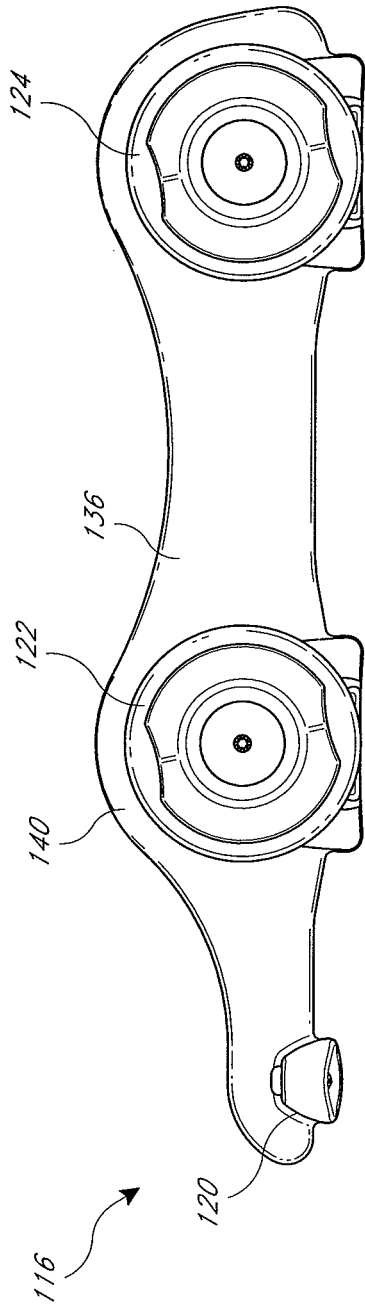

FIG. 3A

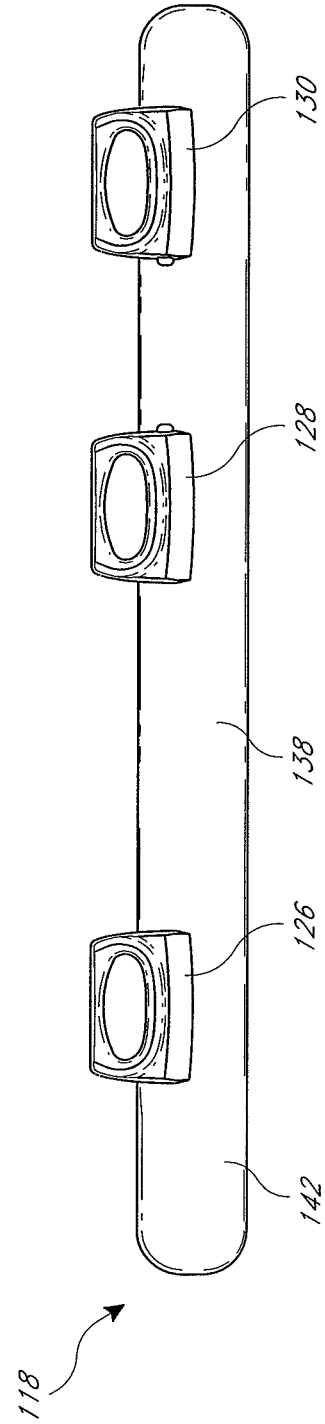

FIG. 3B

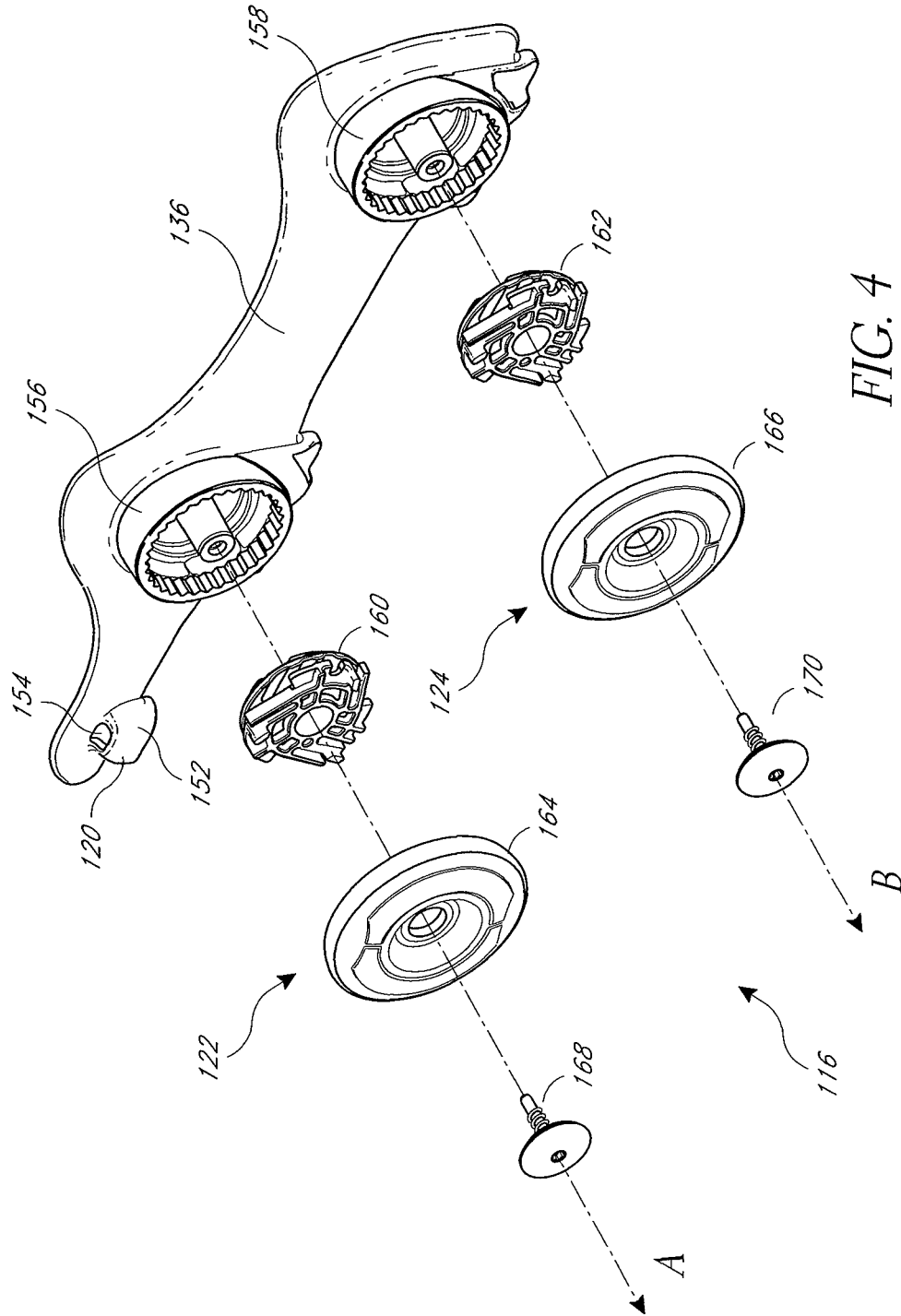

FIG. 4

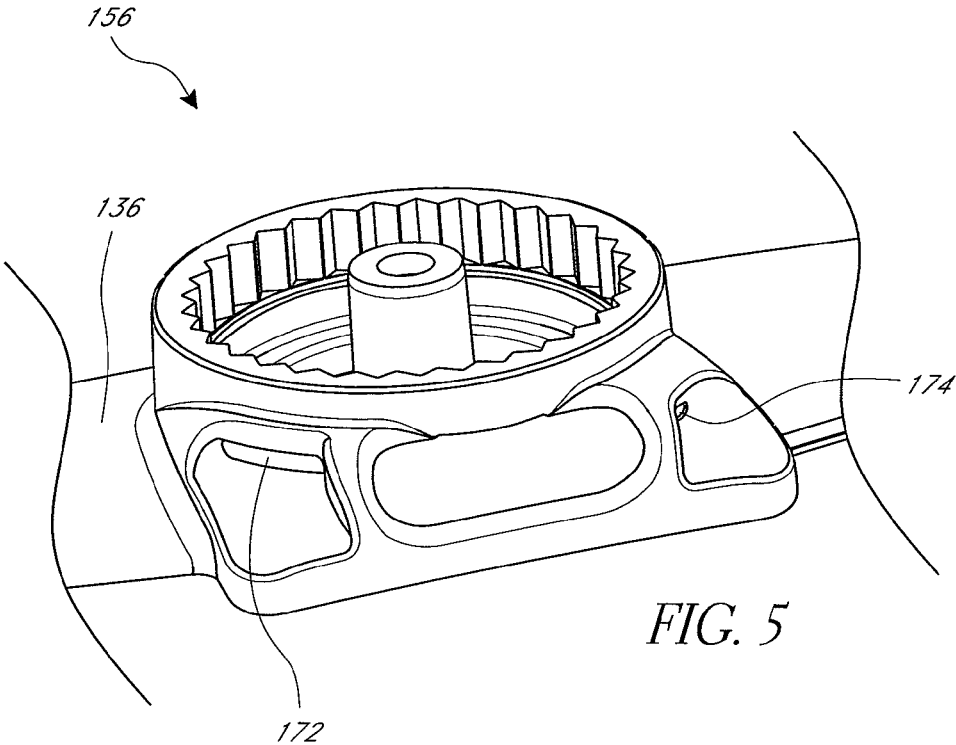

FIG. 5

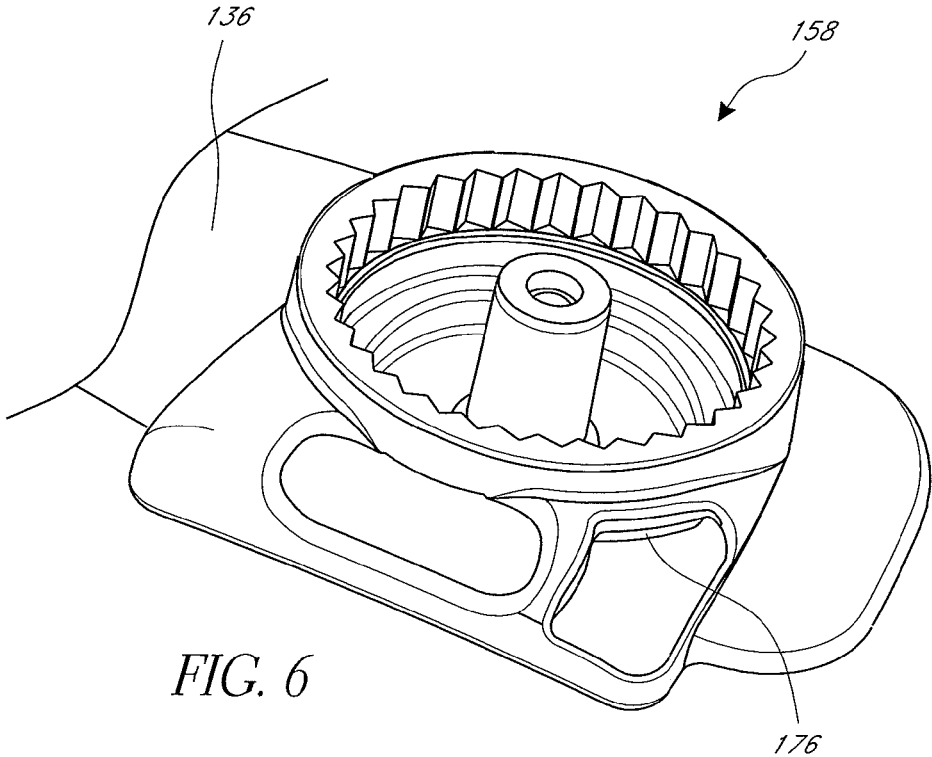
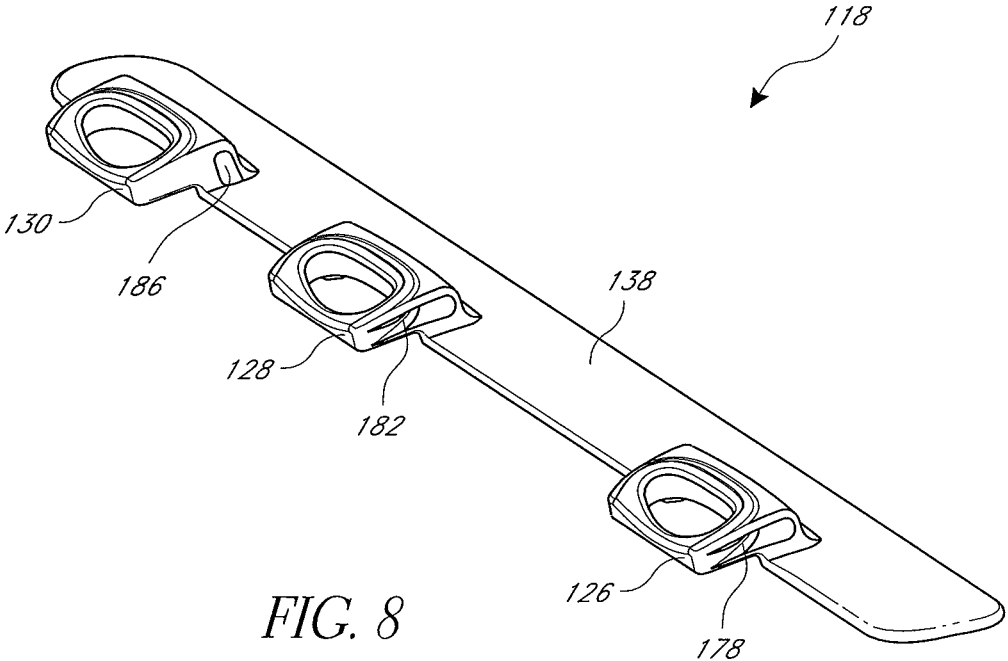
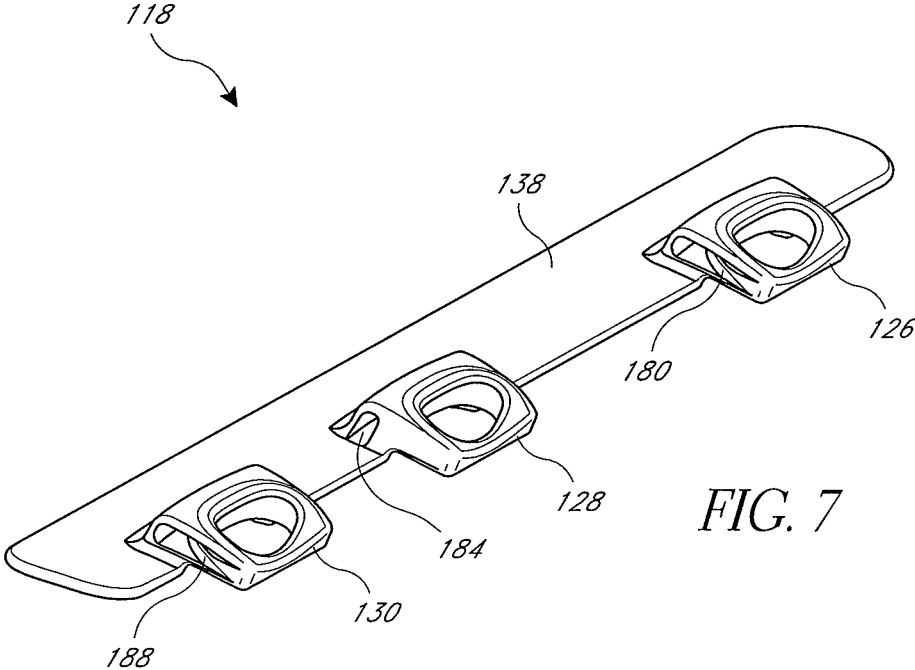

FIG. 6



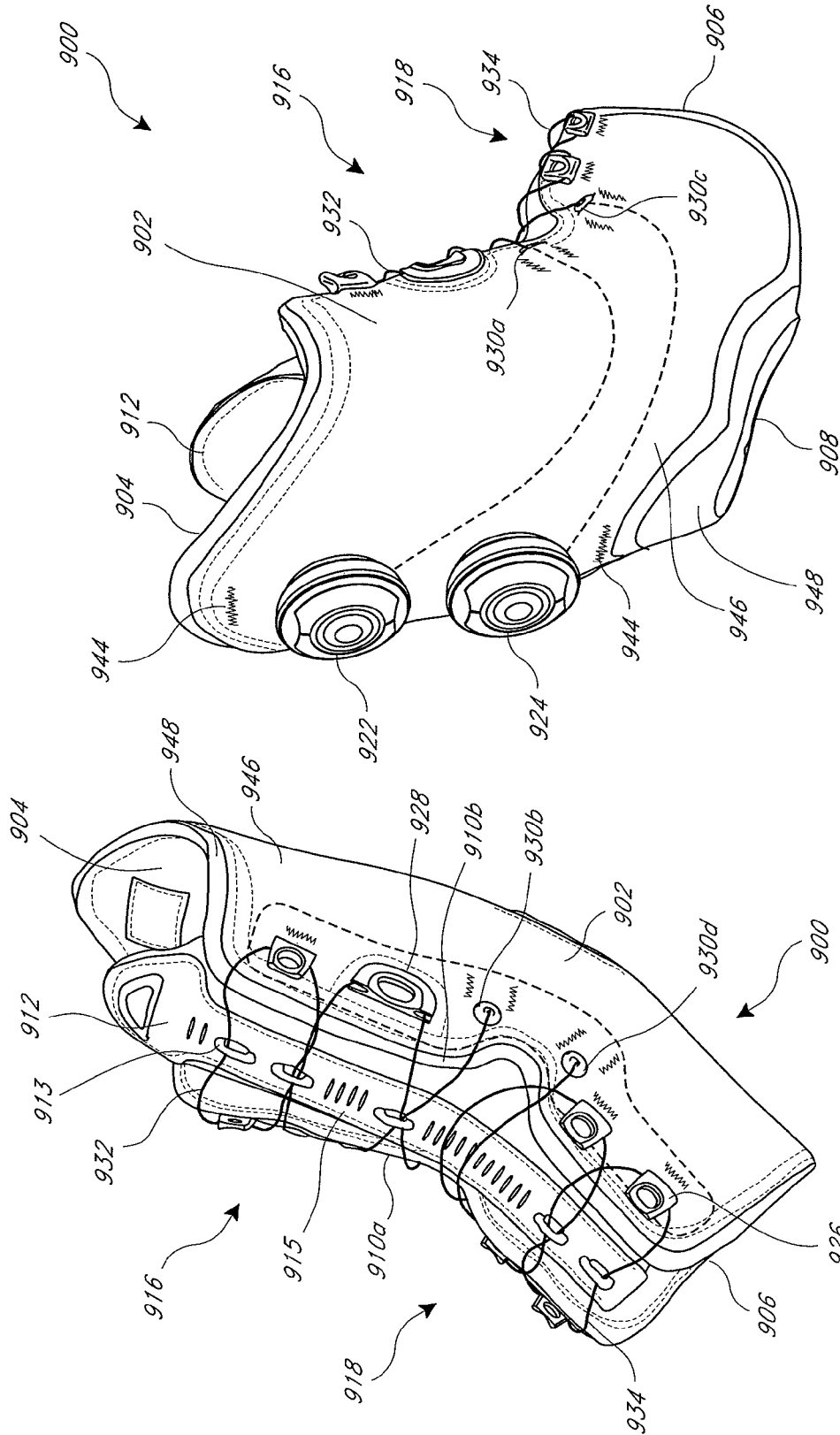

FIG. 10

FIG. 9

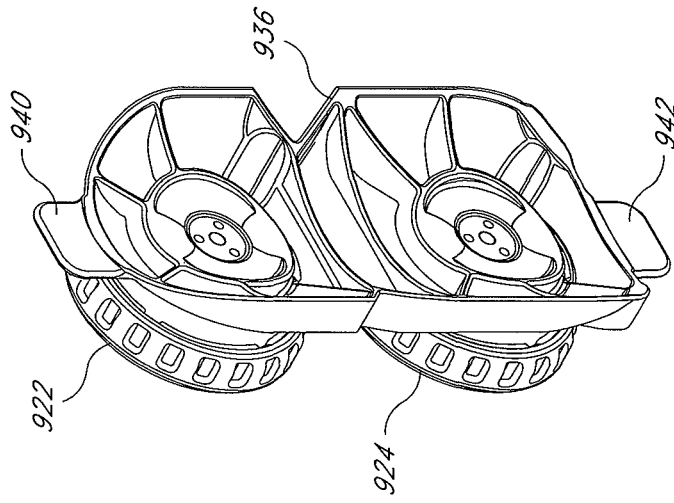

FIG. 12

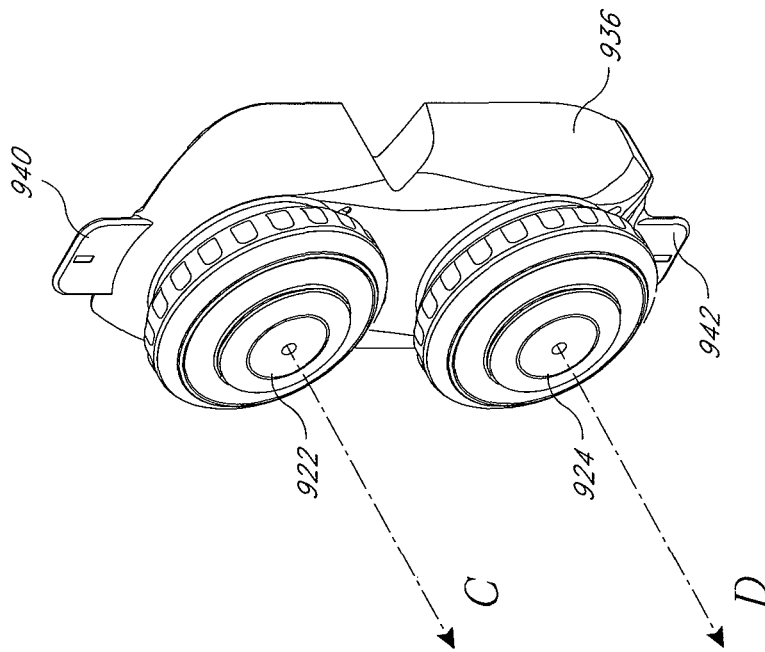

FIG. 11

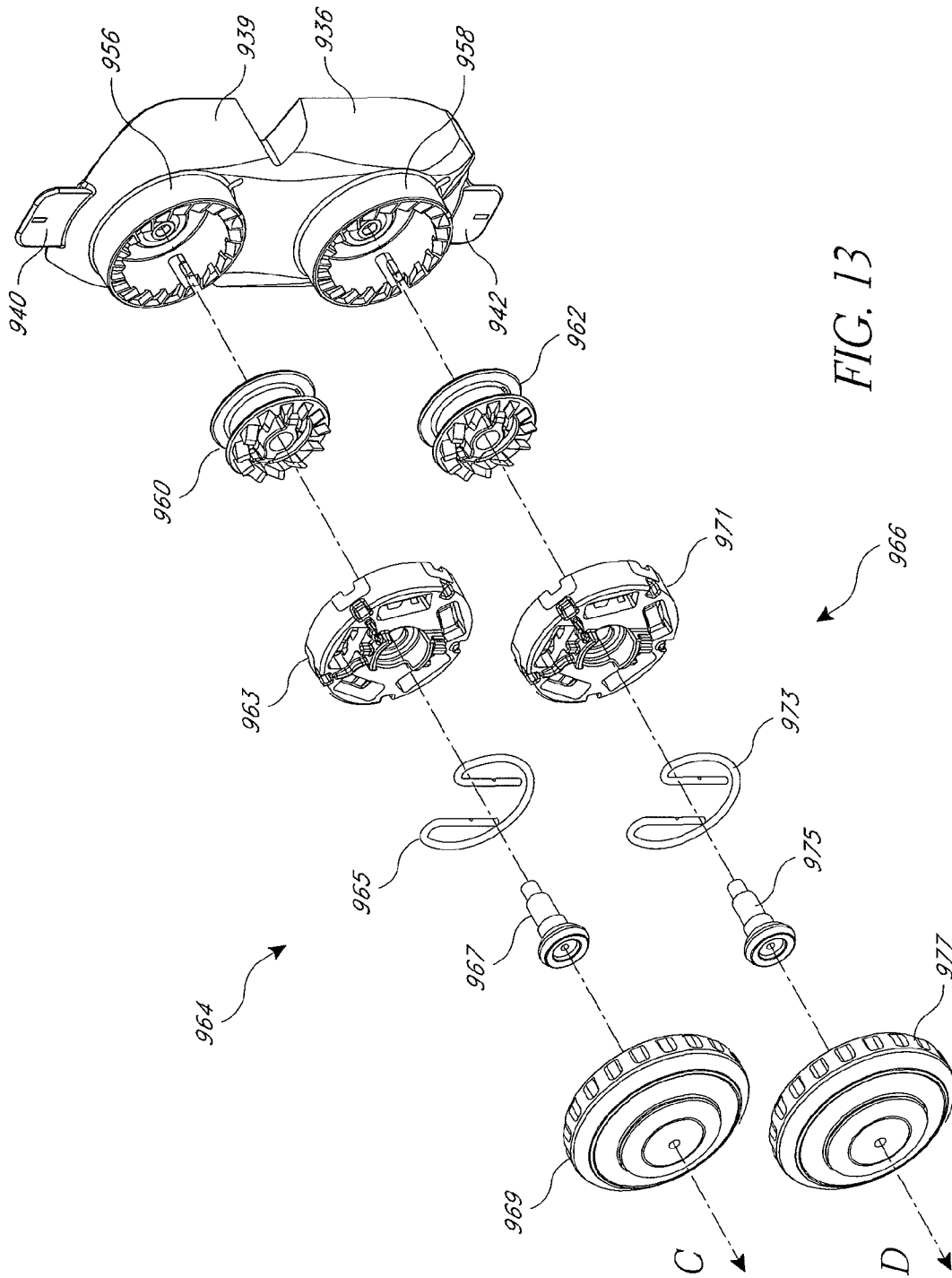

FIG. 13

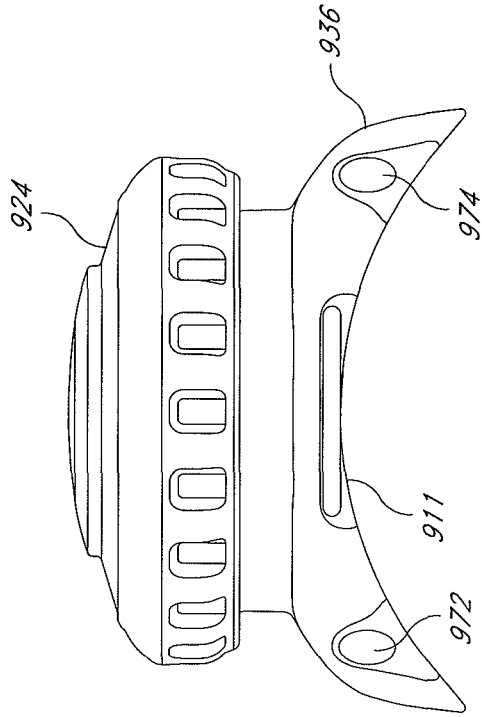

FIG. 15

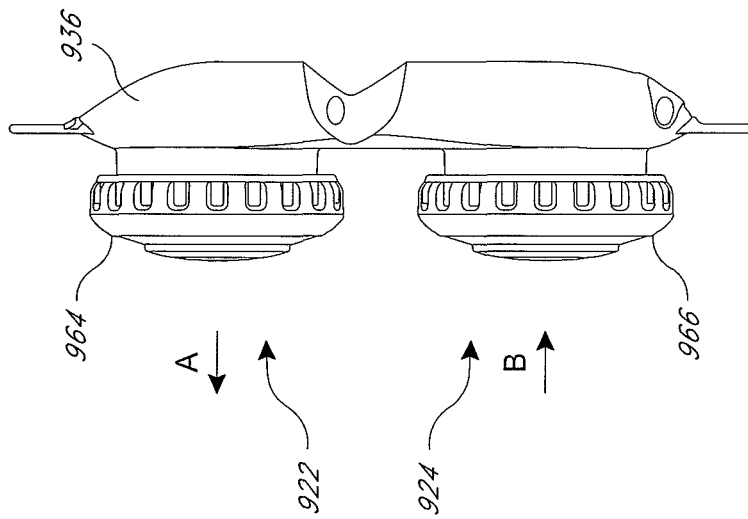

FIG. 14

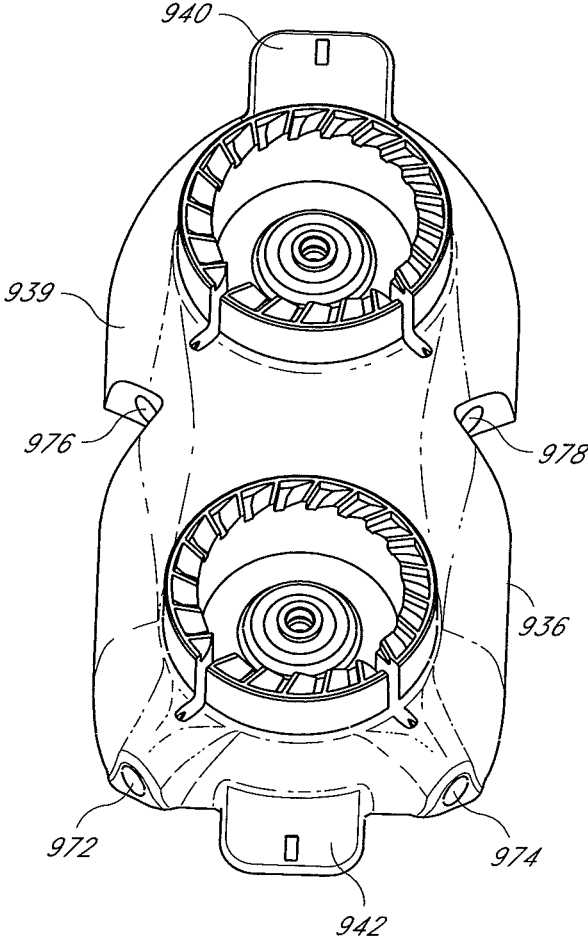

FIG. 16

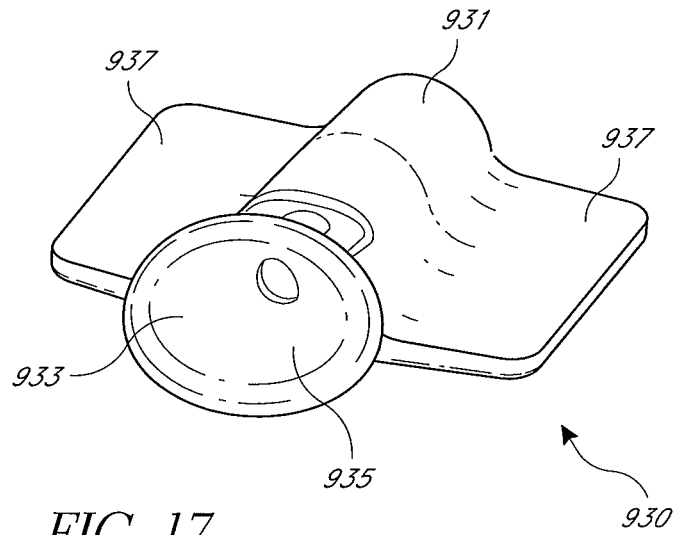

FIG. 17

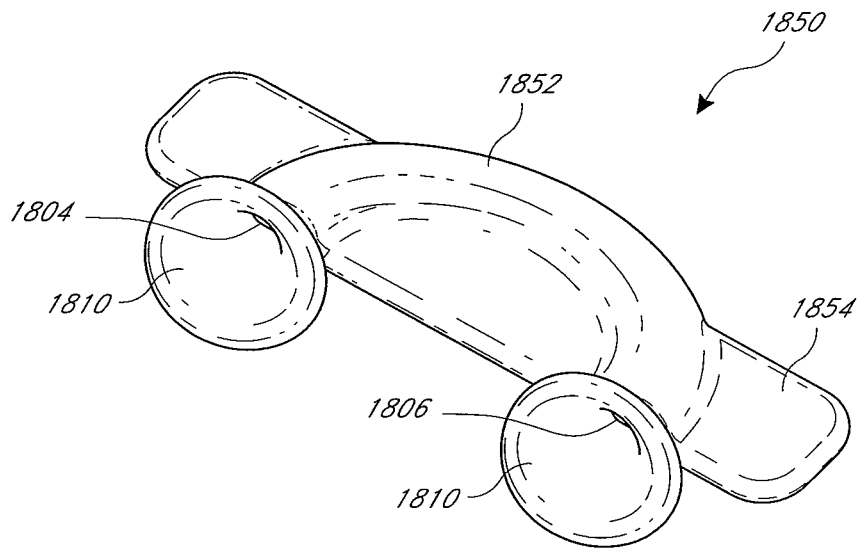

FIG. 19

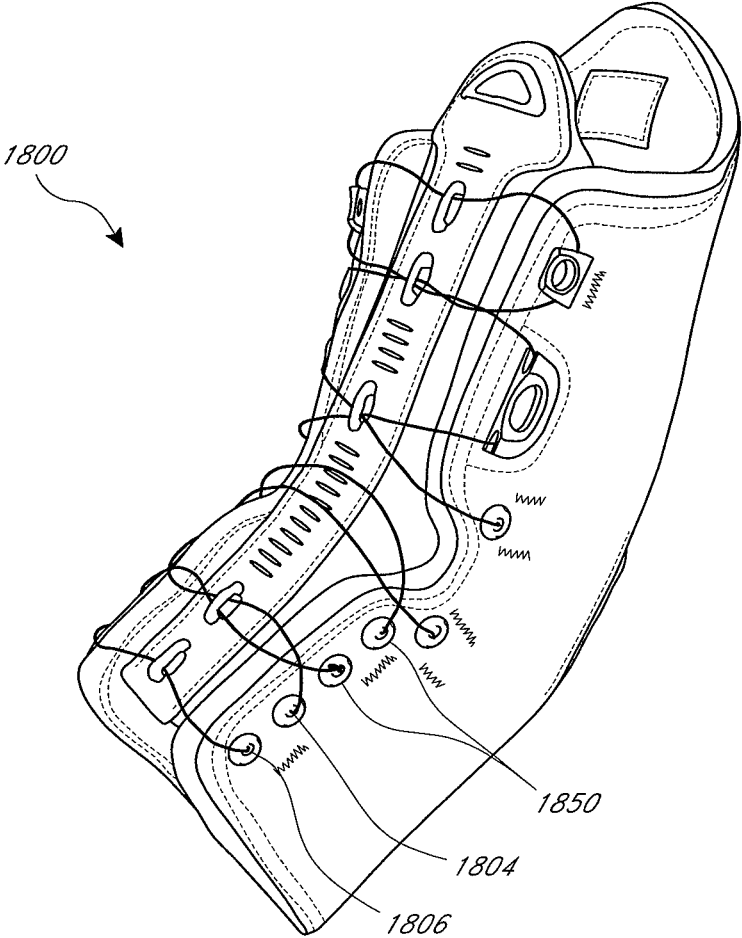

FIG. 18

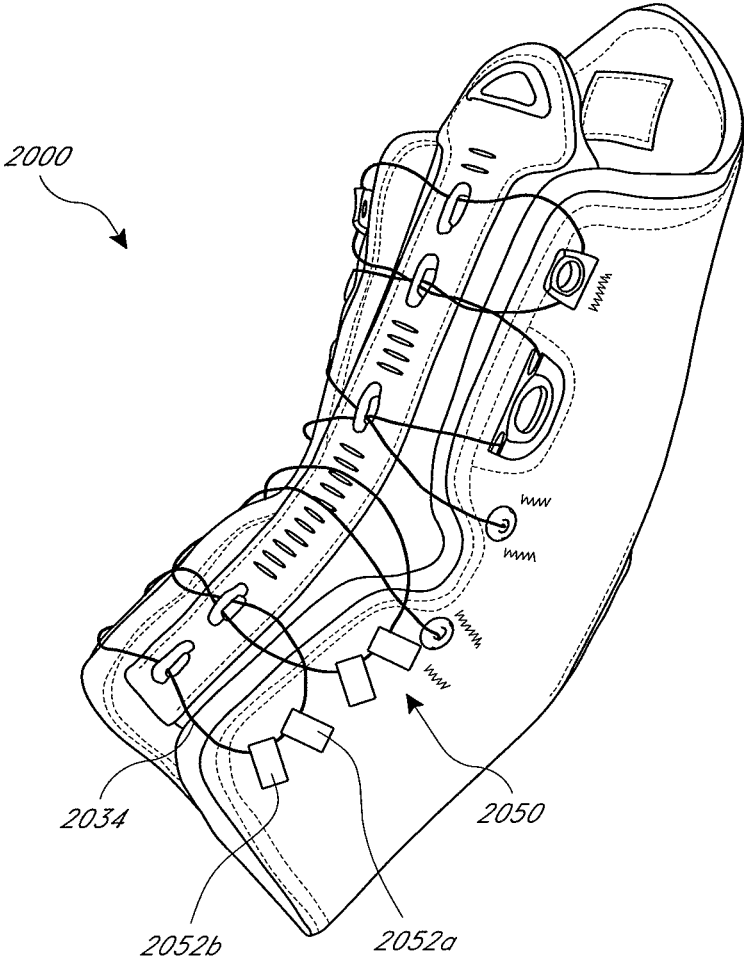

FIG. 20

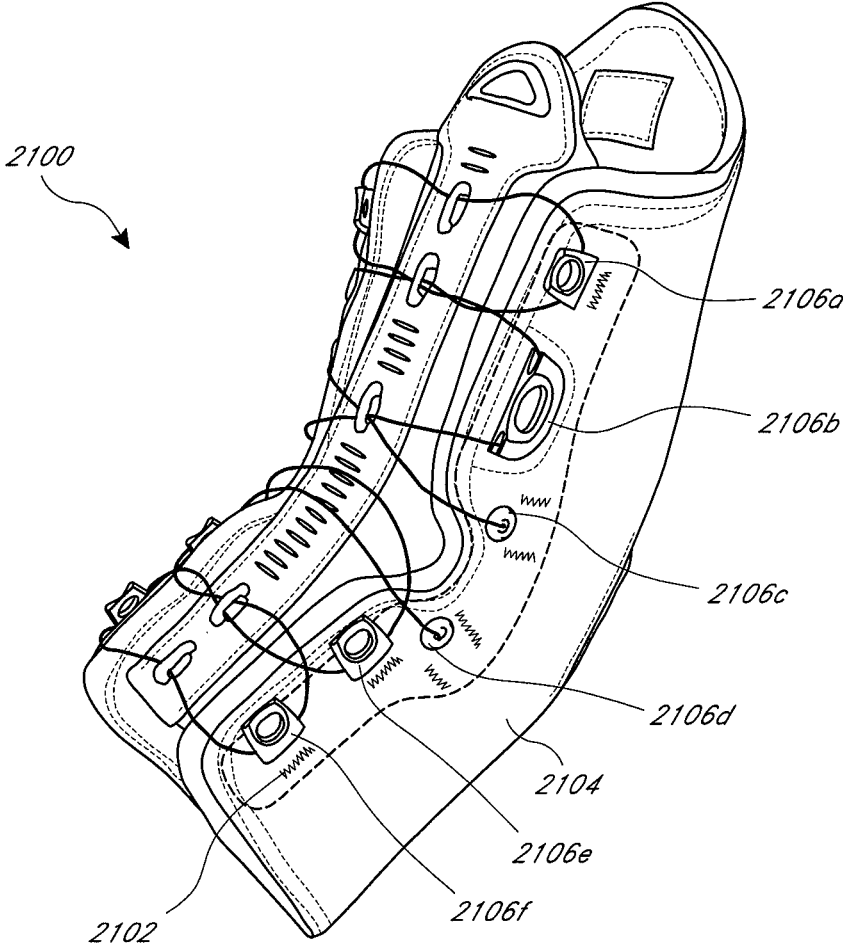

FIG. 21

BRACES USING LACING SYSTEMS**CROSS-REFERENCE TO RELATED APPLICATIONS**

This application claims priority under 35 U.S.C. § 119(e) to U.S. Provisional Application No. 61/360,619, filed on Jul. 1, 2010, and titled "BRACES USING LACING SYSTEMS," the entirety of which is hereby incorporated by reference herein and made a part of this specification for all that it discloses.

BACKGROUND OF THE INVENTION**Field of the Invention**

Embodiments of the present invention relate to medical braces (e.g., wrist braces and ankle braces), and more particularly to medical braces that use lacing systems.

Description of the Related Art

Although various lacing systems are available for use in connection with various wearable articles including medical braces, there remains a need for improvement.

SUMMARY OF THE INVENTION

By way of example and not limitation, a medical brace can include a main body configured to be worn by a user and a lacing system configured to tighten and loosen the main body. The lacing system can include a first reel configured to rotate about a first axis to tighten a first portion of the lacing system, a second reel configured to rotate about a second axis different than the first axis to tighten a second portion of the lacing system, and a housing piece configured to house both the first reel and the second reel.

The housing piece can be substantially rigid and can be configured to provide substantially rigid support to the medical brace. In some embodiments, the medical brace does not include any rigid support member other than the housing piece. The second reel can be positioned adjacent to the first reel. The medical brace can be a wrist brace. The medical brace can be an ankle brace.

The lacing system can further include a plurality of lace guides mounted onto a second housing piece. The second housing piece can be substantially rigid and configured to provide substantially rigid support to the medical brace. In some embodiments, the medical brace does not include any rigid support member other than the housing piece and the second housing piece.

The medical brace can include a first side and a second side that are configured to be drawn together by tightening the lacing system. The first reel and second reel can be positioned on the first side of the medical brace, and the plurality of lace guides mounted onto the second housing piece can be positioned on the second side of the medical brace.

The medical brace can include an upper layer, wherein the first reel and the second reel are positioned above the upper layer, and wherein the housing piece is positioned under the upper layer. The upper layer can include a first hole and a second hole, and the first reel can extend through the first hole and the second reel can extend through the second hole.

A medical brace can include a main body configured to be worn by a user; and a lacing system configured to tighten and loosen the main body. The lacing system can include a lace, a plurality of lace guides configured to provide a lace path for the lace, and a unitary housing piece supporting the plurality of lace guides. A first guide of the plurality of lace

guides can have a first opening and a second opening and a lace channel extending between the first opening and the second opening, a second guide of the plurality of lace guides can have a first opening, a second opening, and a lace channel extending between the first opening and the second opening, and the second opening of the first guide and the first opening of the second guide can be positioned between the first opening of the first guide and the second opening of the second guide. The housing piece can be substantially rigid and can be configured to provide substantially rigid support to the medical brace.

In some embodiments, the medical brace does not include any rigid support member other than the housing piece.

The medical brace can include a first side and a second side that are configured to be drawn together by tightening the lacing system. The plurality of lace guides supported by the unitary housing piece can be positioned on the first side of the medical brace. In some embodiments, no additional lace guides are positioned on the first side of the medical brace.

The plurality of lace guides supported by the unitary housing piece can be spaced apart from each other with portions of the unitary housing piece extending between the lace guides. The plurality of lace guides supported by the unitary housing piece can be arranged generally linearly along a side of the medical brace.

The medical brace can include an upper layer, and the plurality of lace guides can be positioned above the upper layer, while the unitary housing piece can be positioned under the upper layer.

The upper layer can include a plurality of holes corresponding to the plurality of lace guides, and the lace guides can extend through the holes in the upper layer.

BRIEF DESCRIPTION OF THE DRAWINGS

Various embodiments are depicted in the accompanying drawings for illustrative purposes, and should in no way be interpreted as limiting the scope of the inventions.

FIG. 1 is a perspective view of an embodiment of a wrist brace with an embodiment of a lacing system.

FIG. 2 is another view of the wrist brace of FIG. 1.

FIG. 3A is a top view of a first portion of the lacing system of the wrist brace shown in FIG. 1.

FIG. 3B is a top view of a second portion of the lacing system shown FIG. 1.

FIG. 4 is an exploded view of the first portion of the lacing system.

FIG. 5 is a perspective view of a first reel housing.

FIG. 6 is a perspective view of a second reel housing.

FIG. 7 is a perspective view of the second portion of the lacing system.

FIG. 8 is another perspective view of the second portion of the lacing system.

FIG. 9 is a perspective view of an embodiment of an ankle brace with an embodiment of a lacing system.

FIG. 10 is another perspective view of the ankle brace of FIG. 9.

FIG. 11 is perspective view of an example housing and two reels associated therewith.

FIG. 12 is another perspective view of the housing and the two reels.

FIG. 13 is an exploded perspective view of the housing and the two reels.

FIG. 14 is a side view of the housing and the two reels.

FIG. 15 is a bottom view of the housing and the lower reel.

FIG. 16 is a perspective view of the housing.

FIG. 17 is perspective view of a lace guide.

FIG. 18 is a perspective view of another embodiment of an ankle brace.

FIG. 19 is a perspective view of another lace guide.

FIG. 20 is a perspective view of another embodiment of an ankle brace.

FIG. 21 is a perspective view of another embodiment of an ankle brace.

DETAILED DESCRIPTION OF THE PREFERRED EMBODIMENTS

FIG. 1 is a perspective view of a wrist brace 100. The illustrated wrist brace is configured to be used on a left wrist of the wearer, but a similar brace could be made for use on the right wrist by rearranging and modifying the features of the wrist brace 100. Although the illustrated embodiment is a wrist brace, it will be understood that similar features can be incorporated into various other braces or even into other articles such as, but not limited to, hats, gloves, boots, shoes, etc.

The brace 100 can have a main body 102 that can be generally cylindrical to receive the wearer's arm therein. The main body 102 can have a main opening 104 that allows the user's arm to enter the main body 102, and a fingers hole 106, and a thumb hole 108 (hidden from view in FIG. 1). The main body 102 can have edges 110a-b separated by a space that can increase or decrease depending on the size of the wearer's arm and to allow the wearer to put the brace on and to remove the brace. A tongue 112 can be positioned between and under the edges 110a-b, and can be secured to the inside of the main body 102, for example, using an elastic material. In some embodiments, the brace 100 can include a rigid support member (hidden from view) configured to maintain the wearer's wrist in the design orientation with relatively little freedom of movement.

The brace 100 can include a lacing system 114 configured to draw the edges 110a-b towards each other to tighten the brace 100 around the wrist of the wearer. The lacing system 114 can include various components, some of which are shown in the illustrated embodiment, but it will be understood that aspects of the example illustrated lacing system 114 can be altered, omitted, or added to in other embodiments. The lacing system 114 can include a first portion 116 on a first side 110a of the brace 100 and a second portion 118 on a second side 110b of the brace 100 (see the phantom lines in FIG. 2). The first portion 116 can include a lace stop 120, a first reel 122, and a second reel 124. The second portion 118 can include three lace guides 126, 128, 130. Other combinations of reels, guides, and stops can be used.

A first lace 132 can start at the lace stop 120, pass through the first lace guide 126, and enter the first reel 122. The reel 122 can be configured to draw the first lace 132 into the reel 122 when a knob of the reel 122 is rotated about a first axis A in the tightening direction. For example, the end of the lace 132 can be tied or otherwise attached to a spool inside the reel 122 such that as the knob and spool rotate in the tightening directions, the lace 132 will be wound around a lace channel such that additional lace 132 is drawn into the reel 122. In some embodiments, the knob of the reel 122 can be rotated in a loosening direction to incrementally release the first lace 132 from the first reel 122. In some embodiments, the reel 122 can be released (e.g., by lifting the knob of the reel 122 to a raised, disengaged position) to allow the lace 132 to be pulled from the reel 122 for loosening. In some embodiments, both releasing actions are possible.

Thus, the reel 122 can be operable to tighten and loosen a front portion (wrist area) of the brace 100 that is associated with the first lace 132.

A second lace 134 can fixedly start at the first reel 122, run through the second lace guide 128, through the third lace guide 130, and to the second reel 124. In the illustrated embodiment, even though the second lace 134 begins at the first reel 122, rotation of the knob of the first reel 122 does not tighten or loosen the second lace 134. Rather, the second lace 134 is merely tied, or otherwise secured, to the first reel 122. When the knob of the second reel 124 is rotated about a second axis B in the tightening direction, the second lace 134 is drawn into the second reel 124. The second lace 134 can be loosened by rotating the knob in the loosening direction in some embodiments, or by transitioning the reel 124 to a disengaged position that releases the second lace 134 for loosening, or both. Thus, the second reel 124 can be operable to tighten and loosen a back portion (forearm area) of the brace 100 that is associated with the second lace 134. In the illustrated embodiment, the axis A is substantially parallel to the axis B, which in some cases can allow the user to rotate both reels 122, 124 with generally the same hand motion without significant reorientation of the brace 100. Other configurations are possible in which the axis A about which the first reel 122 rotates is not substantially parallel to the axis B about which the second reel 124 rotates. For example, the reels 122, 124 can be located on opposite sides of the brace 100.

In some embodiments, the lace stop 120, first reel 122, and the second reel 124 can all be interconnected or formed as parts of a single first housing piece 136. Similarly, the three lace guides 126, 128, 130 can all be interconnected or formed as parts of a single second housing piece. FIG. 2 is a top view of the wrist brace 100 in which the first housing piece 136 and the second housing piece 138 are shown outlined in dotted lines even though at least a portion of the housing pieces 136, 138 would be hidden from view during normal observation (see FIG. 1). FIG. 3A is a top view of the first portion 116 of the lacing system 114, shown separated from the brace 100. FIG. 3B is a top view of the second portion 118 of the lacing system 114, also shown separated from the brace 100. The first and second housing pieces 136, 138 can include stitch flanges 140, 142 or areas configured to receive stitching to secure the first and second housing pieces 136, 138 to the brace 100. Alternatively, these flanges could be used for adhesive application, RF welding, or insert molding into the main body 102. Turning back to FIG. 2, a stitch line 144 can pass through the upper layer 146 of the brace 100, through the stitch flange 142, and through an underlying layer 148. In some embodiments, the upper layer 146 covers only a part of the brace, leaving part of the underlying layer 148 exposed and visible. In some embodiments, the underlying material 148 can include neoprene, or any other suitable materials. The underlying material 148 can be a multilayer material. Additional stitch lines 150a-c can be used to secure the first housing piece 136 to the brace 100. In some embodiments, a single stitch line can be used for securing the first housing piece to the brace 100 between the upper layer 146 and the underlying layer 148. The upper layer 146 can include holes therein that correspond to the lace stop 120, first reel 122, second reel 124, and the lace guides 126, 128, 130 such that these components of the lacing system can be positioned on the exterior of the brace 100 while the interconnecting housing pieces 136, 138 can be positioned under the upper layer 146, hidden from view.

Joining the lace stop 120, the first reel 122, and the second reel 124 onto a single interconnected housing piece 136

5

provides the benefit that the brace **100** can be produced more quickly, more reliably, and at less cost. It can be less time consuming and cheaper to mold one housing piece than three separate pieces. During assembly, it can be simpler to properly position a single housing piece to be secured (e.g., by stitching) to the brace **100** than to properly position three separate pieces. Thus, the occurrence of erroneously positioned pieces can be reduced. Because the positions of the components of the lacing system **114** affect the fit of the brace **100** on the wearer's arm, if the components are misplaced, the brace **100** may not fit properly and the wearer's arm may be not protected and/or treated properly by the brace. Also, in some instances, a single stitch line (e.g., **144**) can be used instead of multiple stitch lines when multiple components are joined into a single housing piece, further streamlining the assembly process. Additionally, the interconnection of the components may also serve as a therapeutic stiffener for fixation and may be tailored in thickness to achieve a desired stiffness distribution and contour for the desired therapeutic affect.

Turning now to FIG. 4, which is an exploded perspective view of the first portion **116** of the lacing system **114**. The lace stop **120** can be formed as an integral piece with the first housing piece **136**. The lace stop **120** can be a generally wedge-shaped structure **152** with a hole **154** formed there-through. The end of the first lace **132** can be fed through the hole **154** and a knot can be tied or a fitting may be crimped at the end of the first lace **132**, thereby preventing the lace **132** from being pulled back through the hole **154**.

The first housing piece **136** can include a first reel housing **156** and a second reel housing **158** as integral pieces thereof, or as separate pieces attached thereto. The reel housings **156**, **158** can be configured to receive corresponding spool members **160**, **162** therein. Knobs **164**, **166** can engage the spool member **160**, **162**, and can be secured to the corresponding reel housings **156**, **158** by center screws **168**, **170**. In the illustrated embodiment, the reels **122**, **124** can be configured to incrementally tighten when the knobs **164**, **166** are rotated in a tightening direction and to incrementally loosen when the knobs **164**, **166** are rotated in a loosening direction. Additional details regarding the reels **122**, **124** are disclosed in U.S. application Ser. No. 12/623,362 (the "'362 application"), filed Nov. 20, 2009, and titled REEL BASED LACING SYSTEM, which is hereby incorporated herein by reference in its entirety and made a part of this specification for all that it discloses. Specifically, at least the embodiments shown in FIGS. 3-25 of the '362 application relate to a reel based lacing system configured to incrementally tighten and incrementally loosen.

Although the illustrated embodiment is shown as having reels that incrementally tighten and incrementally loosen, it will be understood that any other suitable type of reel or mechanism for tightening the lace of a lacing system can be used. Other reel designs that may be used in connection with the reels **122**, **124** are disclosed in U.S. Provisional patent application Ser. No. 13/098,276 (the "'276 application"), filed Apr. 29, 2011, and titled REEL BASED LACING SYSTEM, which is hereby incorporated herein by reference in its entirety and made a part of this specification for all that it discloses, as well as in U.S. patent application Ser. No. 11/842,013 (the "'013 application"), filed Aug. 20, 2007, titled REEL BASED CLOSURE SYSTEM, published as Publication No. 2008/0066346 on Mar. 20, 2008, which is hereby incorporated herein by reference in its entirety and made a part of this specification for all that it discloses.

FIG. 5 is a close-up perspective view of the reel housing **156**. The end of the first lace **132** can enter into the reel

6

housing **156** through the hole **172**. The hole **172** can be an elongate slot type hole such that the lace **132** can enter the hole **172** from a range of directions without being forced to turn a sharp corner by the walls of the hole **172**. The first lace **132** can be attached to the spool member **160** such that when the spool member **160** and knob **164** rotate, the lace **132** is either pulled into the reel housing **156** or driven out of the reel housing **156** via the hole **172**.

The end of the second lace **134** can be secured to the reel housing **156** via the hole **174**. The lace **134** can be inserted through the hole **174** and a knot can be tied or a fitting may be crimped to the end of the lace **134** such that the lace cannot be pulled back through the hole **174**. The second lace **134** merely uses the first reel **122** as a lace stop, and is not drawn into the reel housing **156** when the reel **122** is tightened.

FIG. 6 is a close-up perspective view of the reel housing **158**. The end of the second lace **134** can enter into the reel housing **158** through the hole **176**. The hole **176** can be an elongate slot type hole such that the lace **134** can enter the hole **176** from a range of directions without being forced to turn a sharp corner by the walls of the hole **176**. The second lace **134** can be attached to the spool member **162** such that when the spool member **162** and knob **166** rotate, the lace **134** is either pulled into the reel housing **158** or driven out of the reel housing **158** via the hole **176**. As can be seen, for example, in FIGS. 1 and 2, in some embodiments, the lace **134** can enter the side of the reel **124** that is furthest toward the back of the brace **100** so that the when the reel **124** is tightened, the back end of the brace **100** can be made to fit sufficiently firm on the wearer's arm.

FIG. 7 is a perspective view of the second portion **118** of the lacing system **114**. FIG. 8 is another perspective view of the second portion **118** of the lacing system **114**. In some embodiments, the lace guides **126**, **128**, **130** can be integrally formed as part of the second housing piece **138**. The lace guides **126**, **128**, **130** can be separately formed and attached to the second housing piece **138** by a fastener or an adhesive or any suitable manner of attachment. The lace guides **126**, **128**, **130** can be closed back lace guides, although open back lace guides may also be used. The lace guides **126**, **128**, **130** can be specially positioned on the second housing piece **138** at locations that correspond to the lace path associated with the reels **122**, **124** and the lace stop **120**. Also, as can be seen by comparing FIGS. 7 and 8 to FIGS. 1 and 2, which show the lacing pattern, the sides of the lace guides **126**, **128**, **130** can be configured according to the anticipated lace path through the lace guides **126**, **128**, **130**. The lace guide **126** has a first curved exit path **178** on a first side to receive the lace coming from the lace stop **120**, and a second curved exit path **180** on the other side to receive lace coming from the reel **122**. The lace guide **128** can have a curved exit path **182** on a first side to receive lace from the reel **122**, and a hole **184** that points generally toward the lace guide **130** to direct the lace toward the lace guide **130**. The lace guide **130** can have a hole **186** than can align collinearly with the hole **184** to receive the lace from the guide **128**, and a curved exit path **188** on the opposite side of the hole **186**. The curved exit paths **178**, **180**, **182**, and **188** and the holes **184**, **186** can provide a lace path that includes no corners of less than about a 3 mm radius, or no corners of less than about a 7 mm radius, or no corners of less than about a 10 mm radius, although curvatures outside of these ranges are also possible.

Many variations are possible. For example, in some embodiments a single lace guide can be used in place of the two lace guides **128** and **130**. To preserve the lace path

shown in FIGS. 1 and 2, for example, the single lace guide that replaces the guides 128 and 130 would need to be about three times the length of the lace guides shown in the illustrated embodiment. It should be understood that the components of the lacing system 114 are merely examples, and components can be rearranged or omitted and additional components can be added. In another arrangement, loops of webbing could be preassembled to the interconnection flange 138 to provide a soft and low profile guiding element for the lace. This preassembly could be via rivets, stitching, insert molding or other fastening means.

In some embodiments, the first housing piece 136 and/or the second housing piece 138 can provide support or structure to the brace 100. In some embodiments, a substantially rigid or semi-rigid material can be used for the housing piece 136 and/or 138. A hardness in the range of about 40 Shore D to about 85 Shore D would provide this range of stiffness although other hardnesses may be used. The first housing piece 136 and/or the second housing piece 138 can be used in conjunction with a conventional support member (e.g., positioned under the wrist on a wrist brace) or in place of the conventional support member to restrict movement of the wearer's arm. Thus, in some embodiments the conventional support member commonly used in wrist braces can be omitted from the brace 100 and the first housing piece 136 and/or the second housing piece 138 can provide the rigid support to the brace 100. In some embodiments, the first housing piece 136 and/or the second housing piece 138 can be positioned on the underside of the wrist, generally opposite of their positions in the illustrated embodiment.

In some embodiments, a somewhat flexible and resilient material can be used to form the housing piece 136 and/or 138 to thereby provide structure to the brace 100 without rigidly restricting movement thereof. In some embodiments the first housing piece 136 and/or the second housing piece 138 can be flexible enough to allow the user to bend the portion(s) of the brace 100 that houses the first housing piece 136 and/or the second housing piece 138, but the resilient nature of the material can cause the brace 100 to return to substantially its original position once bending force is released. This stiffness may be controlled via both thickness and hardness. Thicknesses from about 0.7 mm to about 4.0 mm and hardnesses in the range of about 20 Shore D to about 85 Shore D may be employed.

In some embodiments, the housing piece 136 can be made from a single material and can be formed as a single unitary piece. The housing piece 138 can likewise be made from a single material and can be formed as a single unitary piece. In some embodiments, different portions of the housing pieces 136, 138 can be made from different material having different levels of hardness, or other differences in properties. Using the housing piece 138 as an example, the stitch flange 142 can be made from a first material, and the lace guides 126, 128, 130 can be made from a different material, for example, by overmolding the guides 126, 128, 130 onto the stitch flange 142. In some embodiments, the stitch flange 142 can be made from a harder, more rigid material than the lace guides 126, 128, 130. In some cases the stitch flange 142 can be rigid so as to provide support to the brace 100, and in some cases it can be advantageous to form the lace guides 126, 128, 130 from a material that is softer than the outer material of the lace so that friction between the guides and the lace will tend to wear the guides 126, 128, 130 rather than the outer surface of the lace. In some embodiments, the stitch flange 142 can be made from a material that is softer than the lace guides 126, 128, 130, such as when the stitch flange 142 is configured to be somewhat flexible to allow

movement of the brace 100, and/or when the lace guides 126, 128, 130 are formed from a relatively hard material to prevent wearing of the lace guides during use. The housing piece 136 can similarly be made from multiple materials having different properties, such as hardness. For example, the lace stop 120, the first reel housing 156, and/or the second reel housing 158 can be made of a material that is either harder or softer than the material used to form the stitch flange 140.

FIG. 9 is a perspective view of an embodiment of an ankle brace 900. FIG. 10 is another perspective view of the ankle brace 900. The ankle brace 900 can be symmetrical for use on either the right or left foot, or it can be specifically designed for use on either the left or right foot. It will be understood that many of the feature and principles discussed in connection with the ankle brace 900 can also be applied to other braces, for example the wrist brace discussed above, or even to other articles such as, but not limited to, hats, gloves, boots, shoes, etc.

The brace 900 can have a main body 902 that can be generally cylindrical and shaped to receive a foot of a wearer. The main body 902 can have a main opening 904 that allows the user's foot to enter the main body 902, and a toes hole 906, and a heel hole 908. The main body 902 can have edges 910a-b separated by a space that can increase or decrease depending on the size of the wearer's foot and to allow the wearer to put the brace 900 on and to remove the brace 900. A tongue 912 can be positioned between and under the edges 910a-b, and can have a series of tongue guides 913 through which the laces 932, 934 pass to secure the tongue 912 to the main body 902 of the brace 900. The tongue guides 913 can be positioned along a single integrated tongue strip 915 which can be positioned, for example, down the center of the tongue 912. In some embodiments, the brace 900 can include a rigid support member configured to maintain the wearer's foot in the design orientation with relatively little freedom of movement in the wearer's ankle.

The brace 900 can include a lacing system 914 configured to draw the edges 910a-b towards each other to tighten the brace 900 around the foot of the wearer. The lacing system 914 can include various components, some of which are shown in the illustrated embodiment, but it will be understood that aspects of the example illustrated lacing system 914 can be altered, omitted, or added to in other embodiments. The lacing system 914 can include an upper portion 916 configured to use a first lace 932 to tighten an upper portion of the brace 900 around the portion of the user's foot above the heel. The lacing system 914 can include a lower portion 918 configured to use a second lace 934 to tighten a lower portion of the brace 900 around the portion of the user's foot below the heel.

As can be seen in FIG. 10, the lacing system 914 can include a first reel 922 configured to gather the first lace 932 therein to tighten the upper portion 916 of the lacing system. The lacing system 914 can also include a second reel 924 configured to gather the second lace 934 therein to tighten the lower portion 918 of the lacing system 914. FIG. 10 shows in dotted lines one possible embodiment of lace paths that lead the laces 932, 934 to the reels 922, 924. In some embodiments, the two reels 922, 924 can both be mounted onto a single housing piece 936. FIG. 11 is a perspective view of the housing piece 936 and the two reels 922, 924 mounted thereto. FIG. 12 is another perspective view of the housing piece 936 and reels 922, 924 showing the back side of the housing piece 936. The housing piece 936 can be substantially rigid or semi-rigid and can provide structure or

support to the back of the brace **900**. In some embodiments, the rigid housing piece **936** can be used in place of a conventional support member to aid in keeping the wearer's foot in a relatively stable position with little freedom of motion in the user's ankle. This housing piece **936** could also be provisioned with a flange around its periphery to increase the level of support as desired. Positioning multiple reels on a single housing allows greater control of the reels relative to each other and can reduce error and cost during manufacturing.

FIG. **13** is an exploded perspective view of the housing piece **936** and reels **922**, **924**. The housing piece **936** can include an upper reel housing **956** configured to receive a first spool member **960** therein. A first knob **964** can engage the first spool member **960** and rotatably secure to the first reel housing **956**. The first knob **964** can include a knob core **963**, a knob spring **965**, a knob bushing **967**, and a knob cover **969**. The housing piece **936** can also include a lower reel housing **958** configured to receive a second spool member **962** therein. A second knob **966** can engage the second spool member **962** and rotatably secure to the second reel housing **958**. The second knob **966** can include a knob core **971**, a knob spring **973**, a knob bushing **975**, and a knob cover **977**. Additional details regarding the components and functionality of the reels **922**, **924** of the illustrated embodiment are disclosed in the '013 application (at least at FIGS. 38A-46). It will be understood that various other types of reel or lace tightening mechanisms can be used in place of one or both the reel designs **922**, **924** shown in the illustrated embodiment.

Mounting two reels **922**, **924** substantially vertically onto a single housing piece **936** can allow the two reels **922**, **924** to be located closer to each other than were each reel **922**, **924** mounted onto a separate housing piece. In some embodiments, the brace **900** can be configured to be worn with a shoe over the top thereof. If the reels **922**, **924** were placed too low, or too far apart so that they took up too much space on the back of the brace **900**, the lower reel **924** could interfere with the shoe being worn over the top of the brace **900**. Also, because the housing piece **936** forms an integrated, generally elongate, vertically oriented, rigid support on the back portion of the brace **900**, the housing piece **936** provides better support to the brace **900** than would two housing pieces that each house one of the reels **922**, **924**.

The housing piece **936** can have a top stitch flange **940** and a bottom stitch flange **942** which can receive stitching **944**, as shown in FIG. **10** to secure the housing piece **936** between an upper layer **946** and an underlying layer **948** of the brace **900**. Alternatively, this stitch flange may be present around any portion of the periphery. Thus, a portion of the rigid housing piece **936** can be disposed under the upper layer **946** so as to be hidden from view. The reel housings **956**, **958** can extend through holes formed in the upper layer **946** such that the reels **922**, **924** can be mounted onto the external surface of the brace **100** where they can be visible and exposed.

FIG. **14** is a side view of the housing piece **936** and the reels **922**, **924**. In some embodiments, the knobs **964**, **966** can be toggled between an engaged position and a disengaged position. By pulling one of the knobs **964**, **966** away from the housing piece **936** (in the direction of the arrow A), the knob **964**, **966** can be disengaged such that the spool member **960**, **962** is permitted to spin freely. Thus, when disengaged, the lace can be withdrawn from the reels **922**, **924** such that the reels **922**, **924** can be loosened. By pushing one of the knobs **964**, **966** toward the housing piece **936**, the

knob **964**, **966** can be toggled to the engaged position where the knob can only turn in the tightening direction to draw lace into the reels **922**, **924**.

FIG. **15** is a bottom view of the housing piece **936** and the reel **924**. The back surface **911** of the housing piece **936** can be curved to conform to the curvature of brace **900** or approximate the curvature of the wearer's foot that is positioned nearest the back surface **911** of the housing piece **936**. A first end of the lace **934** can enter the housing piece **936** via a hole **972**, and a second end of the lace **934** can enter the housing piece **936** via the hole **974**. The ends of the lace **934** can attach to the second spool member **962** such that when the reel **924** is rotated about a second axis D in the tightening direction the lace **934** is drawn into the reel **924** to tighten the lower portion **918** of the lace system **914**. FIG. **16** is another perspective view of the housing piece **936** that shows additional holes **976**, **978** which can allow the ends of the lace **932** to enter the housing piece **936**. The ends of the lace **932** can connect to the first spool member **960** such that when the reel **922** is rotated about a first axis C in the tightening direction, the lace **932** is drawn through the holes **176**, **178** and into the reel **922** to tighten the upper portion **916** of the lacing system **914**. In the illustrated embodiment, the axis C is substantially parallel to the axis D, which in some cases can allow the user to rotate both reels **922**, **924** with generally the same hand motion without significant reorientation of the brace **900**. Other, configurations are possible in which the axis C about which the first reel **922** rotates is not substantially parallel to the axis D about which the second reel **924** rotates. For example, the reels **922**, **924** can be located on opposite sides of the brace **900**.

In some embodiments the housing piece **936** can be made from a single material and can be a single unitary piece. In some embodiments, the housing piece **936** can be made from multiple materials that can have different properties, such as different levels of hardness. For example, in some embodiments, the main body **939** of the housing piece **936** can be made from a first material. The stitch flanges **940**, **942** can be made from a second material, for example by overmolding, and can have a lower hardness than the first material such that the main body **939** can provide rigid support to the brace **900** while the stitch flanges **940**, **942** can be soft enough to be punctured during the stitching process. In some cases, the main body **939** can be softer than the stitch flanges **940**, **942** such that the body can be somewhat flexible to allow some degree of movement in the brace **900** while the stitch flanges **940**, **942** can be harder to prevent them from being ripped from the stitching by the force of the tightened lacing system **914**. The reel housings **957**, **958** can also be made from a different material than the main body **939** or than the stitch flanges **940**, **942**.

Returning now to FIG. **9**, the brace **100** can include several lace guides configured to provide lace paths for the laces **932**, **934**. Some of the lace guides can be closed back lace guides **926** which can prevent the lace from disengaging from the lace guides **926**. In some embodiments, one or more of the lace guides can be a backless lace guide **928** (e.g., one of the lace guides of the upper portion **916** of the lace system). The lace **932** can be pulled out of the back of the backless lace guide **928** such that the lace **932** completely disengages from the backless lace guide **928**. Once disengaged, the extra length of lace **932** that was previously engaged with the backless lace guide **928** can provide significant slack to the upper portion **916** of the lace system **914**, thereby allowing the brace **900** to open wider to accommodate the insertion of the wearer's foot therein.

Once the user's foot is inserted, the lace **932** can be pulled back onto the backless lace guide **928** to take up the slack previously introduced. This allows the tightener (e.g., one or both of the reels **922**, **924**) to be smaller in that the lace length necessary to provide slack for inserting and removing the wearer's foot need not be stored inside the tightener.

In some embodiments, one or more of the lace guides can direct the lace **932**, **934** to the corresponding reels **922**, **924**. In some embodiments, the top two reel-leading lace guides **930a-b** can lead the ends of the lace **932** to the upper reel **922** via tubing inserted into the lace guides **930a-b** at the first end and inserted into the housing piece **936** at the second end, and the lower two reel-leading lace guides **930c-d** can lead the ends of the lace **934**, also via tubing, to the lower reel **924**. FIG. 17 shows a perspective view of one of the reel-leading lace guides **930a-d**. The reel-leading lace guide **930** can have a lace channel portion **931** that can be disposed below the upper layer **946** of the brace **900** such that the lace channel portion **931** is hidden from view during normal use. In some embodiments, the lace channel **931** can be longer than as shown in the illustrated embodiment and can lead to one of the reels **922**, **924**. In some embodiments, the lace channel **931** can lead to a supplemental channel, for example a polymer tube (not shown), that leads to the reels **922**, **924**. An end piece **933** can be positioned at least partially on the outside of the upper layer **946** such that the end piece **933** is exposed and visible. The end piece can have a non-uniform flange **935** around the opening to the lace channel that extends further at the bottom than at the top. The flange **935** can be generally bell-shaped. The end piece can provide a curved sliding surface for the lace **932**, **934** to slide against as it passes in or out of the lace channel. One or more stitch flanges **937** can be used to secure the lace guide **930** to the brace **900** with stitching, although other attachment methods can be used.

FIG. 18 is a perspective view of an ankle brace **1800** that can be similar to, or the same as, the ankle brace **900** discussed herein. In some embodiments, the brace **1800** can have included low profile lace guides **1850** that can be similar in some regards to the lace guides **930** discussed above. The lower profile lace guides can facilitate the use of the brace **1800** with a shoe worn over the top thereof. In some embodiments, each of the lace guides of the lower portion **1818** of the lace system **1814** can be low profile lace guides **1850**.

FIG. 19 is a perspective view of a lower profile lace guide **1850** that includes a lace channel **1802** that can be disposed below an upper layer **1846** of the brace **1800** when assembled (as shown in FIG. 18). The lace guide **1850** can have a generally U-shaped lace channel **1852** with the lace passing from a first opening **1804** to a second opening **1806**. The lace guide **1850** can include an end piece **1810** at each opening. The end piece **1810** can be similar to, or the same as the end piece **933** discussed above. A stitch flange **1852** can be used to stitch the lace guide **1850** to the brace **1800**.

FIG. 20 is a perspective view of another embodiment of an ankle brace **2000** having low profile lace guides **2050**. In some embodiments, one or more of the low profile lace guides **2050** can include a pair of angled loops **2052a**, **2052b** of, for instance, a woven polymer webbing, similar to the lace guides described in U.S. patent application Ser. No. 13/011,707 (the "'707 application"), filed Jan. 21, 2011, and titled "GUIDES FOR LACING SYSTEMS," the entirety of which is hereby incorporated by reference herein and made a part of this specification for all that it discloses. The lace **2034** can pass through two consecutive loops on one side before being directed to the opposite side, as described in

greater detail in the '707 application. Other low profile lace guides can be used, such as, for example, those disclosed in connection with FIGS. 1-2B of the '707 application. The illustrated embodiment of FIG. 20 shows certain lace guides located on the lower portion of the brace **2000** having low profile lace guides **2050** (e.g., the angled loop pairs **2052a**, **2052b**), which can allow a shoe to be worn over the top of the brace **2000**. As will be clear from the disclosure, low profile laces such as angled loop pairs similar to **2052a** and **2052b** can be used for the other lace guides on the brace **2000**. For example, in some embodiments, all the lace guides on the brace **2000** can be low profile lace guides.

FIG. 21 is a perspective view of another embodiment of an ankle brace **2100** in which multiple lace guides are incorporated into a single housing piece. The single housing piece **2102** is shown in dotted lines in FIG. 21 because it is hidden from view below the upper layer **2104** of the brace **2100**. In the illustrated embodiment, all six of the lace guides **2106a-f** on the left side of the brace **2100** are incorporated into the single housing piece **2102**, although in some embodiments a different number of lace guides **2106** can be incorporated into a single housing, and in some cases multiple housings can be used each incorporating multiple lace guides. For example, lace guides **2106a-c** can be incorporated into one housing and the lace guides **2106d-f** can be incorporated into a different housing. Many variations are possible. Joining multiple lace guides by a single housing piece can provide benefits similar to those discussed above in connection with the wrist brace **100**. For example, the cost to manufacture the lace guides can be reduced if less pieces are required. Also, assembly of the brace **2100** can be simplified and the occurrence of erroneously positioned pieces can be reduced. Additionally, the housing piece can provide additional support and structure to the brace **2100** along with appropriate points of flexure.

While discussed in terms of certain embodiments, it should be appreciated that the disclosure is not so limited. The embodiments are explained herein by way of example, and there are numerous modifications, variations and other embodiments that may be employed that would still be within the scope of the present invention. Components can be added, removed, and/or rearranged both within certain embodiments and between embodiments. Additionally, processing steps may be added, removed, or reordered. A wide variety of designs and approaches are possible. Where numerical values and/or ranges are disclosed, other numerical values can also be used. For example, some embodiments can use numerical values that are outside the disclosed ranges.

For purposes of this disclosure, certain aspects, advantages, and novel features of embodiments of the invention are described herein. It is to be understood that not necessarily all such advantages may be achieved in accordance with any particular embodiment of the invention. Thus, for example, those skilled in the art will recognize that the invention may be embodied or carried out in a manner that achieves one advantage or group of advantages as taught herein without necessarily achieving other advantages as may be taught or suggested herein.

What is claimed is:

1. A medical brace comprising:
 - a main body configured to be worn by a user; and
 - a lacing system configured to tighten and loosen the main body, the lacing system comprising:
 - a first reel configured to rotate about a first axis to tighten a first portion of the lacing system;

13

- a second reel configured to rotate about a second axis different than the first axis to tighten a second portion of the lacing system; and
 a first unitary housing piece coupled to the body and configured to house and connect both the first reel and the second reel, wherein the medical brace is configured to restrict movement of a portion of the user anatomy.
2. The medical brace of claim 1, wherein the lacing system further comprises a plurality of lace guides mounted onto a second housing piece.
3. The medical brace of claim 2, wherein the second housing piece is substantially rigid and configured to provide substantially rigid support to the medical brace.
4. The medical brace of claim 2, wherein the first housing piece is substantially rigid and is configured to provide substantially rigid support to the medical brace, and wherein the medical brace does not include any rigid support member other than the first housing piece and the second housing piece.
5. The medical brace of claim 2, wherein the medical brace comprises a first side and a second side that are configured to be drawn together by tightening the lacing system, wherein the first reel and second reel are positioned on the first side of the medical brace, and wherein the plurality of lace guides are positioned on the second side of the medical brace.
6. The medical brace of claim 1, wherein the first housing piece is substantially rigid and is configured to provide substantially rigid support to the medical brace.
7. The medical brace of claim 6, wherein the medical brace does not include any rigid support member other than the housing piece.
8. The medical brace of claim 1, wherein the second reel is positioned adjacent to the first reel.
9. The medical brace of claim 1, wherein the medical brace is a wrist brace.
10. The medical brace of claim 1, wherein the medical brace is an ankle brace.
11. The medical brace of claim 1, wherein the first axis and the second axis are substantially parallel.
12. The medical brace of claim 1, wherein the first reel includes a first reel housing, the second reel includes a second reel housing, and wherein the first and second reel housing are coupled to or integral with the first housing piece.
13. The medical brace of claim 1, wherein at least a portion of the first housing piece comprises a material that is softer or harder than the reel.
14. A medical brace comprising:
 a main body configured to be worn by a user; and
 a lacing system configured to tighten and loosen the main body, the lacing system comprising:
 a lace;
 a plurality of lace guides configured to provide a lace path for the lace, wherein a first guide of the plurality of lace guides comprises a first opening and a second

14

- opening and a lace channel extending between the first opening and the second opening, wherein a second guide of the plurality of lace guides comprises a first opening, a second opening, and a lace channel extending between the first opening and the second opening, and wherein the second opening of the first guide and the first opening of the second guide are positioned between the first opening of the first guide and the second opening of the second guide;
- a first reel configured to rotate about a first axis to tighten a first portion of the lacing system;
 a second reel configured to rotate about a second axis different than the first axis to tighten a second portion of the lacing system;
 a first unitary housing piece coupled to the body, and configured to house and connect both the first reel and the second reel; and
 a second unitary housing piece supporting the plurality of lace guides, wherein the medical brace is configured to restrict movement of a portion of the user anatomy.
15. The medical brace of claim 14, wherein the second housing piece is substantially rigid and is configured to provide substantially rigid support to the medical brace.
16. The medical brace of claim 15, wherein the first housing piece is substantially rigid and is configured to provide substantially rigid support to the medical brace, and wherein the medical brace does not include any rigid support member other than the first housing piece and the second housing piece.
17. The medical brace of claim 14, wherein the medical brace comprises a first side and a second side that are configured to be drawn together by tightening the lacing system, wherein the plurality of lace guides are positioned on the first side of the medical brace, and wherein no additional lace guides are positioned on the first side of the medical brace.
18. The medical brace of claim 14, wherein the plurality of lace guides are spaced apart from each other with portions of the second, unitary housing piece extending between the lace guides.
19. The medical brace of claim 14, wherein the plurality of lace guides are arranged generally linearly along a side of the medical brace.
20. The medical brace of claim 14, wherein the first reel includes a first reel housing, the second reel includes a second reel housing, and wherein the first and second reel housing are coupled to or integral with the first housing piece.
21. The medical brace of claim 14, wherein at least a portion of the first housing piece comprises a material that is softer or harder than the reel.

* * * * *